



AND

FORWARD PHYSICS AT THE LHC

Particle Physics Seminar, Brookhaven National Laboratory

Jonathan Feng, UC Irvine, 25 March 2021



SIMONS
FOUNDATION



HEISING-SIMONS
FOUNDATION



HOT OFF THE PRESS

CERN Bulletin

Issue No. 12-13/2021-Thursday 25 March 2021

More articles at <http://home.cern/cern-people>

LS2 REPORT: FASER IS BORN

FASER, the Forward Search Experiment, has been installed in the LHC tunnel during Long Shutdown 2. It is currently being tested and will start taking data next year



The final elements of FASER were put into place this month. (Image: CERN)

A WORD FROM CHARLOTTE LINDBERG WARAKAULLE

EXCELLENCE IN SCIENCE
THRIVES ON GLOBAL
INTERACTION

A year ago, it seemed that the world closed around us. From one day to the next, travel and movement became restricted. The usual in-person exchanges with colleagues from across the world suddenly became a rare occurrence.

(Continued on page 2)

In this issue

News	1
LS2 Report: FASER is born	1
A word from Charlotte Lindberg Warakaulle	2
CERN and Fermilab map out HL-LHC collaboration	3
LHC key handed back for operation	4
CMS launches initiative to support Lebanese colleagues	4
Aligning the ATLAS muon spectrometer	5
Tackling tomorrow's computing	

OUTLINE

MOTIVATIONS

FORWARD PHYSICS

FASER

FASER_v

FORWARD PHYSICS FACILITY

FLArE

SUMMARY

MOTIVATIONS

LHC: CURRENT STATUS

- The discovery of the Higgs boson in 2012 completed the standard model of particle physics, but so far there has been no other direct evidence for new particles from the LHC.
- The LHC is currently in Long Shutdown 2, but will start up again in 2022 and run till ~2037. Will we find new particles through conventional searches?
- What other approaches can enhance the prospects for discovering new physics?

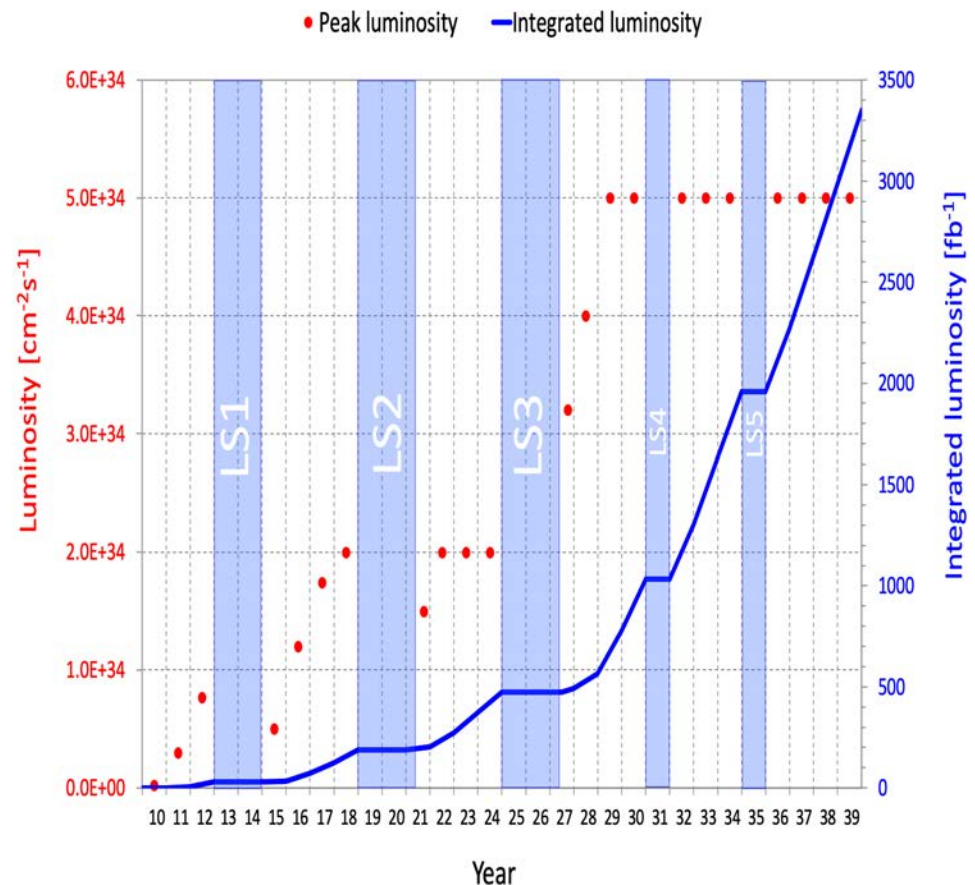

THE NEW PARTICLE LANDSCAPE

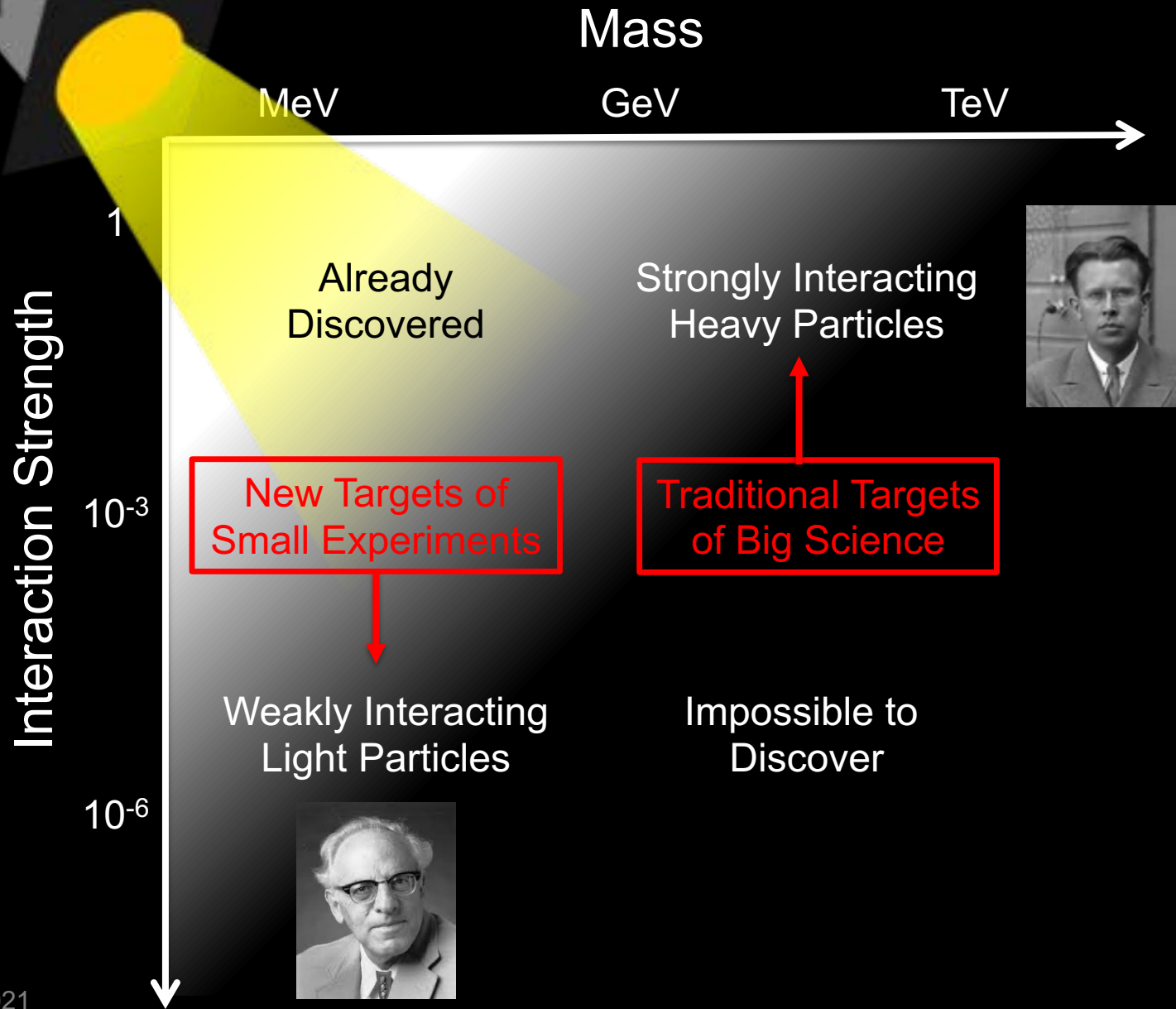

AN EXAMPLE: DARK PHOTONS

- Suppose there is a dark sector that contains dark matter X and also a dark force: dark electromagnetism.
- Generically, the force carriers of the SM and dark EM will mix

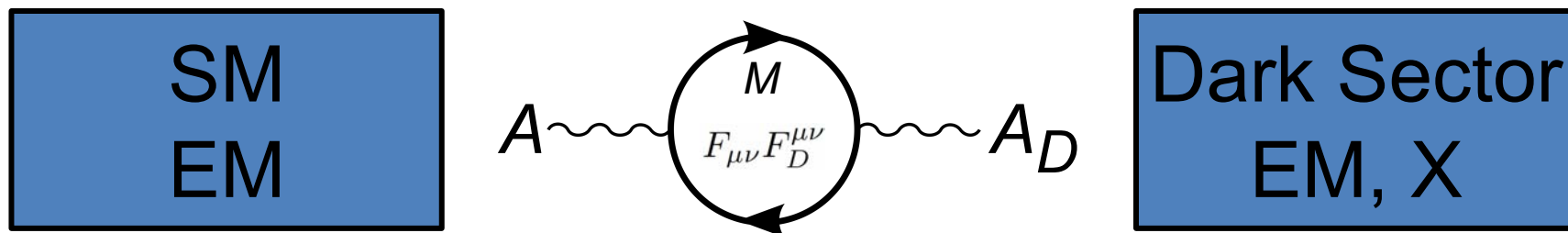

- The resulting theory contains a new particle, the **dark photon A'** . It's like a normal photon, except that it can have a small mass, $m_{A'}$, and its couplings to charged particles are suppressed by a small parameter ϵ : it is **a weakly-interacting, light particle**.

Holdom (1986)

- Finding a dark photon would imply the discovery of a new fundamental force and also our first “portal” through which to view the dark sector.

DARK PHOTON PROPERTIES

- Consider mass $m_{A'}$ \sim 1-100 MeV and coupling $\epsilon \sim 10^{-6} - 10^{-3}$.
- Production:** through meson decay, dark bremsstrahlung,

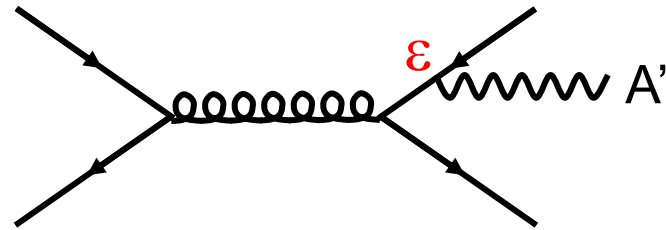
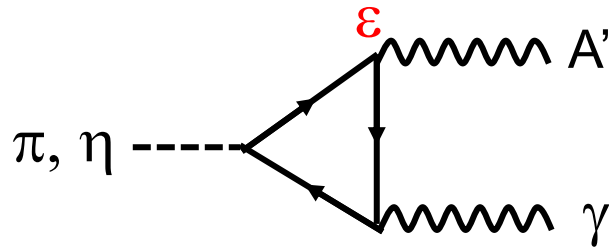

- Propagation:** they pass through matter without interacting, and they go straight, unaffected by E and B fields.
- Decay:** they may decay to visible particles, but only after a long time:

$$L = v\tau\gamma \sim (100 \text{ m}) \left[\frac{10^{-5}}{\epsilon} \right]^2 \left[\frac{100 \text{ MeV}}{m} \right]^2 \left[\frac{E}{\text{TeV}} \right]$$

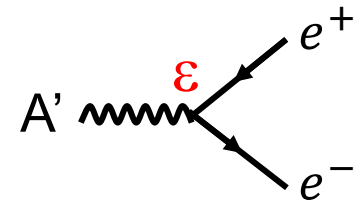

They are generically long-lived particles (LLPs) !

THE THERMAL RELIC LANDSCAPE

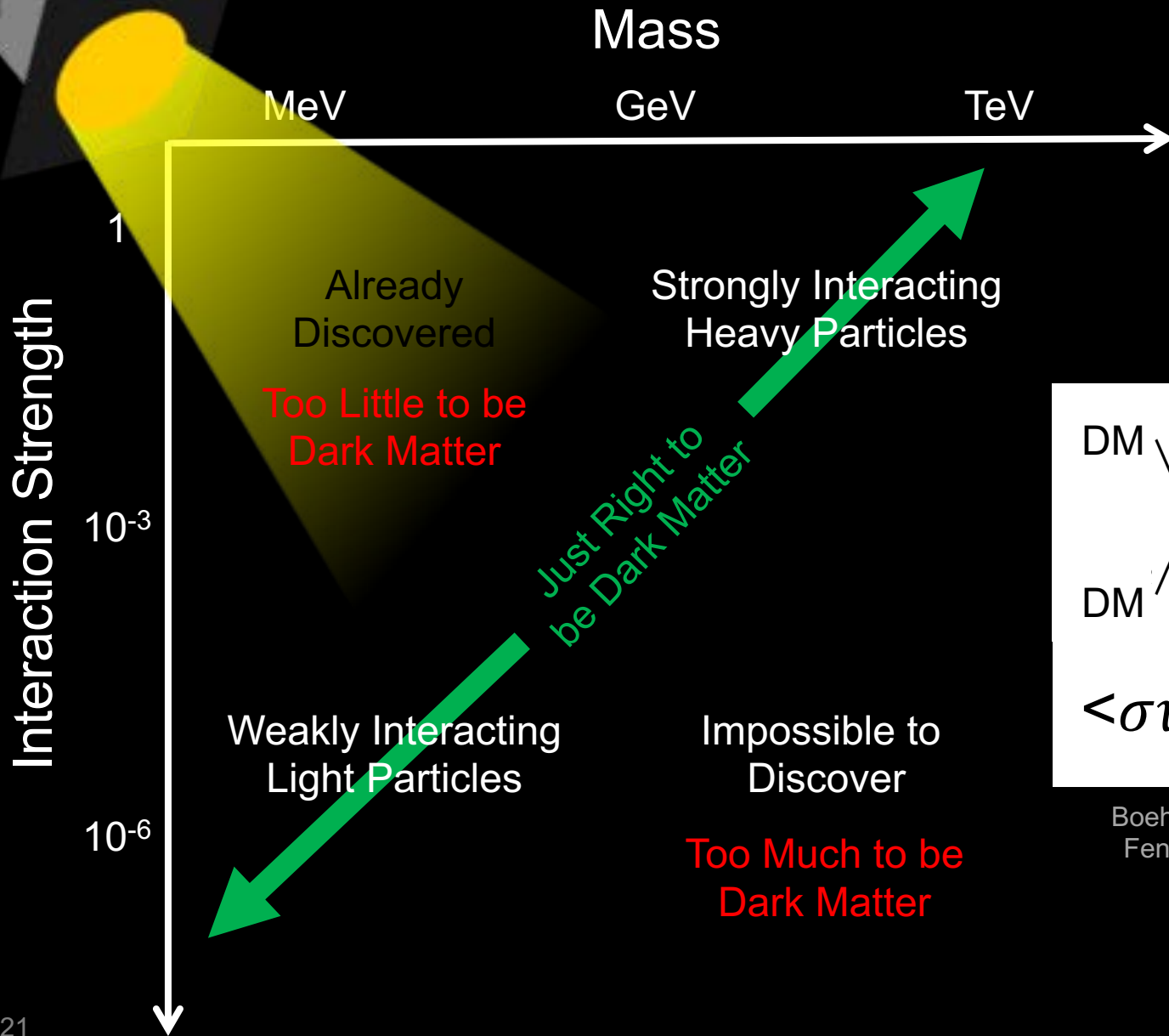

$$\langle \sigma v \rangle \sim \frac{\epsilon^2}{m_{A'}^2}$$

Boehm, Fayet (2003)
Feng, Kumar (2008)

FORWARD PHYSICS

SEARCHES FOR NEW LIGHT PARTICLES

- If new particles are light and weakly interacting, existing LHC detectors are perfectly designed **NOT** to see them.
- Existing detectors are designed to find new **heavy** particles. These particles are produced almost at rest and decay isotropically.

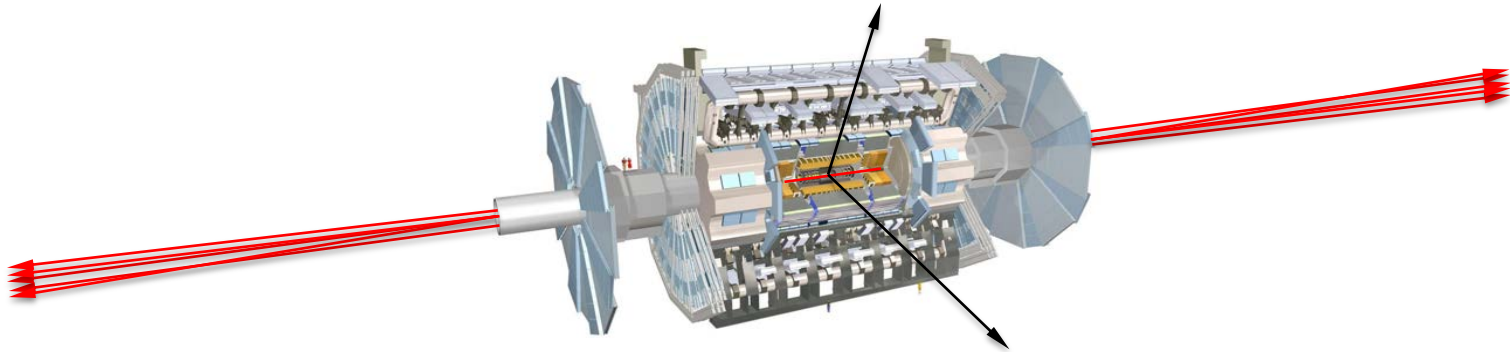

- But new **light** particles are mainly produced in the decays of light particles: π , η , K , D and B mesons. These are mainly produced along the beamline, and so the new particles disappear through the holes that let the beams in.
- Clearly we need a detector to exploit the “wasted” $\sigma_{\text{inel}} \sim 100 \text{ mb}$ and cover these “blind spots” in the **forward region**. If we go far enough away, the proton beams are bent by magnets (it’s a circular collider!), whereas the new light particles will go straight.

MAP OF LHC

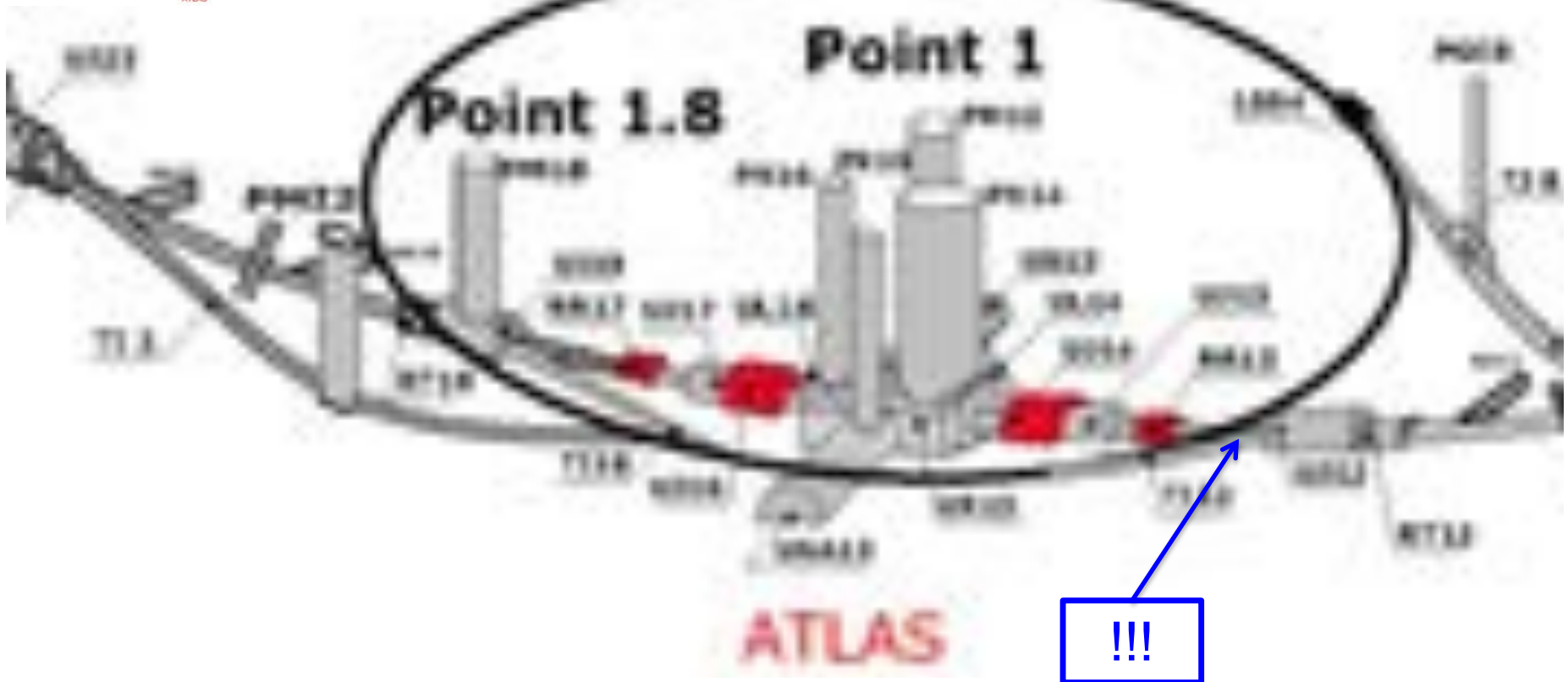
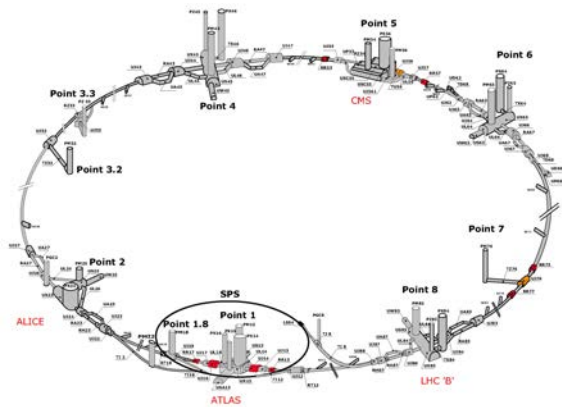

LOCATION, LOCATION, LOCATION

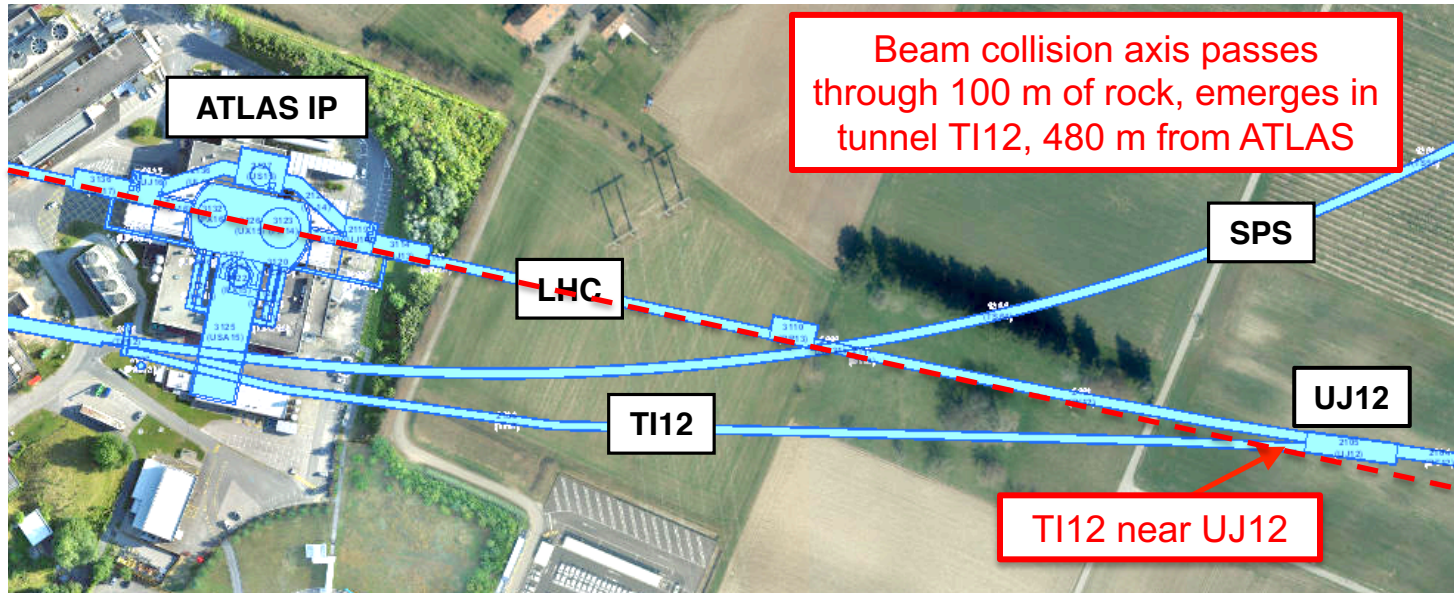

PARTICLE PATH FROM ATLAS TO T112

Dougherty, CERN Integration (2019)



HOW BIG DOES THE DETECTOR HAVE TO BE?

Consider dark photons: $\pi^0 \rightarrow A' \gamma$, A' travels 480 m, then decays: $A' \rightarrow e^+ e^-$

Pions at the IP

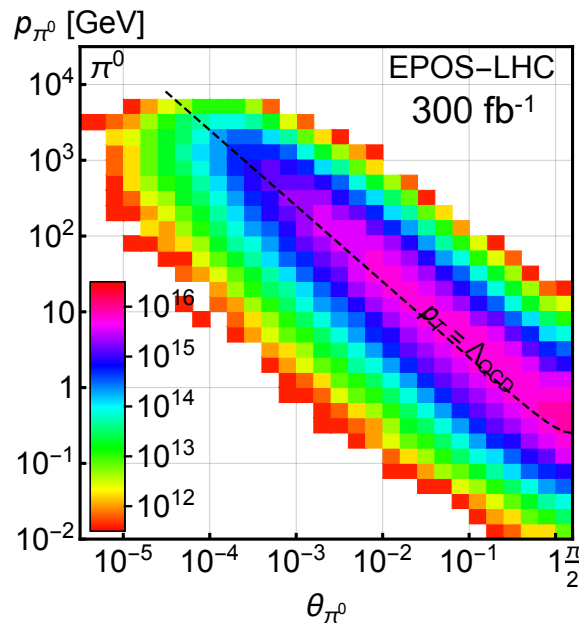

A' 's at the IP

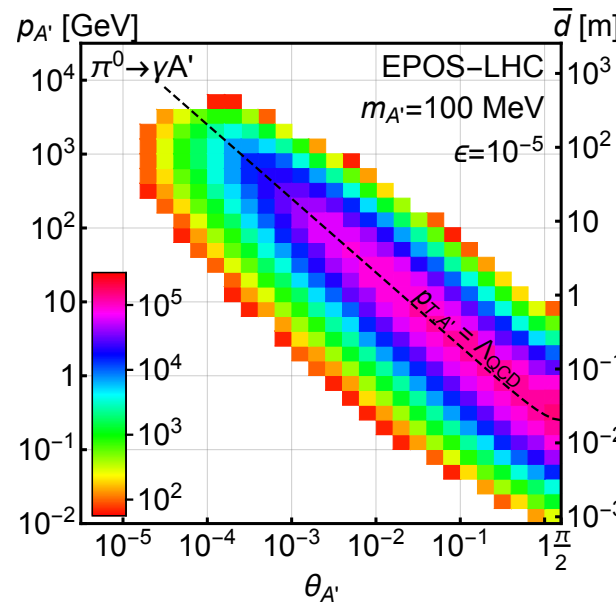

A' 's decay in [480m, 483m]

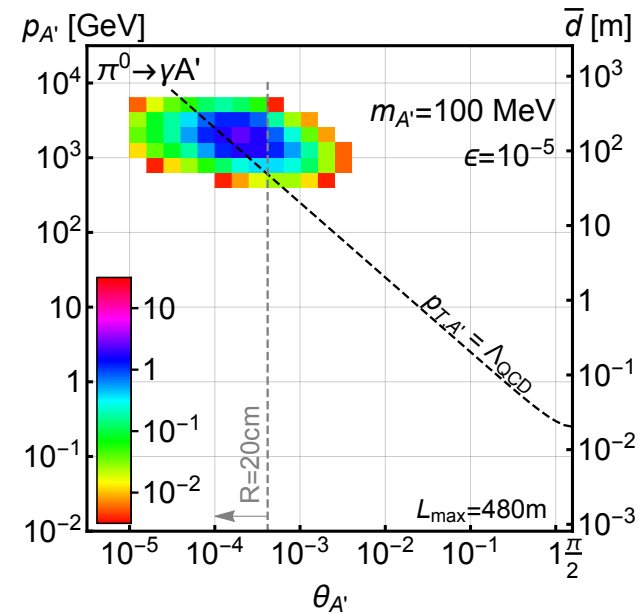

- Production is peaked at $p_T \sim m_\pi, \Lambda_{\text{QCD}} \sim 250 \text{ MeV}$
- Enormous event rates: $N_\pi \sim 10^{15}$ per bin
- Rates highly suppressed by $\epsilon^2 \sim 10^{-10}$
- But still $N_{A'} \sim 10^5$ per bin
- Only highly boosted $\sim \text{TeV}$ A' 's decay in FASER
- $N_{A'} \sim 100 e^+e^-$ events, within 20 cm of “on axis”

Feng, Galon, Kling, Trojanowski (2017)

HOW BIG DOES THE DETECTOR HAVE TO BE?

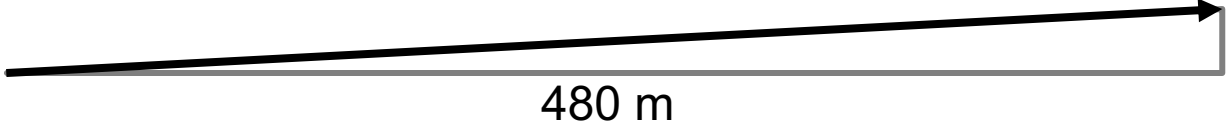
- Momentum:  200 MeV
- Space:  10 cm

- The opening angle is 0.2 mrad ($\eta \sim 9$); cf. the moon (7 mrad).
- TeV dark photons (or any other new particles produced in π , η , K , D , B decay) are far more collimated than shown below, motivating a new, small, fast, cheap experiment at the LHC.

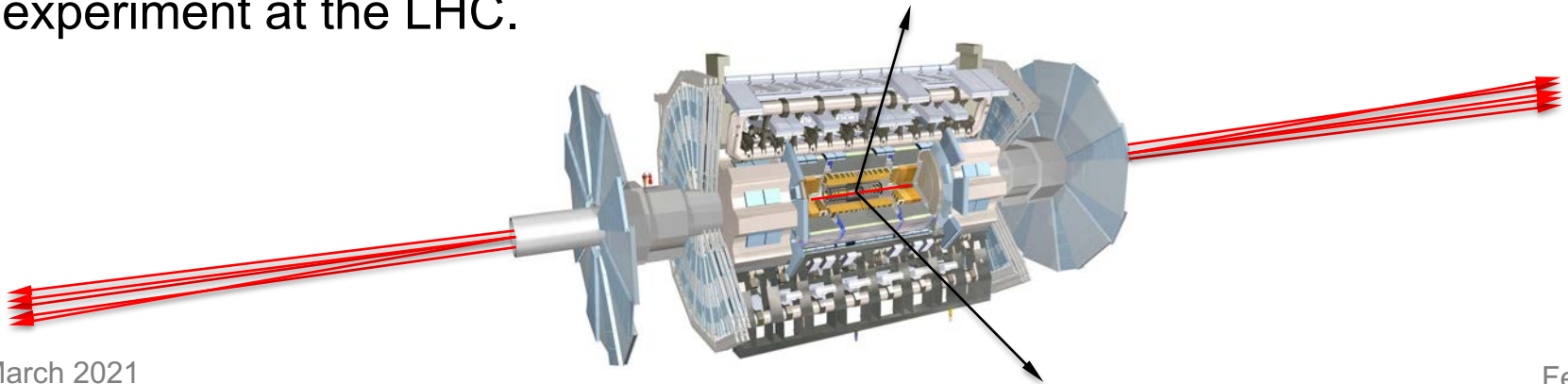

FASER

FASER TIMELINE

- September 2017: Proposed by Feng, Galon, Kling, Trojanowski.
- July 2018: Submitted LOI to CERN LHCC
- October 2018: Approval from [ATLAS SCT](#) and [LHCb Collaborations](#) for use of spare detector modules
- November 2018: Submitted Technical Proposal to LHCC
- November 2018 – January 2019: Experiment funded by grants from the [Heising-Simons](#) and [Simons Foundations](#)
- March 2019: FASER fully approved by [CERN LHCC](#) and [Research Board](#) along with support for infrastructure costs
- April 2019: 1st FASER Collaboration Meeting
- November 2020 – March 2021: Installation of FASER in tunnel during Long Shutdown 2, commissioning of the detector
- Early 2022: Start collecting data in Run 3

FIRST FASER COLLABORATION MEETING



THE FASER COLLABORATION TODAY

70 collaborators, 19 institutions, 8 countries

Henso Abreu (Technion), Yoav Afik (Technion), Claire Antel (Geneva), Akitaka Ariga (Bern), Tomoko Ariga (Kyushu/Bern), Florian Bernlochner (Bonn), Tobias Boeckh (Bonn), Jamie Boyd (CERN), Lydia Brenner (CERN), Franck Cadoux (Geneva), Dave Casper (UC Irvine), Charlotte Cavanagh (Liverpool), Xin Chen (Tsinghua), Andrea Coccaro (INFN), Monica D'Onofrio (Liverpool), Candan Dozen (Tsinghua), Yannick Favre (Geneva), Deion Fellers (Oregon), Jonathan Feng (UC Irvine), Didier Ferrere (Geneva), Stephen Gibson (Royal Holloway), Sergio Gonzalez-Sevilla (Geneva), Carl Gwilliam (Liverpool), Shih-Chieh Hsu (Washington), Zhen Hu (Tsinghua), Peppe Iacobucci (Geneva), Tomohiro Inada (Tsinghua), Sune Jakobsen (CERN), Enrique Kajomovitz (Technion), Felix Kling (SLAC), Umut Kose (CERN), Susanne Kuehn (CERN), Helena Lefebvre (Royal Holloway), Lorne Levinson (Weizmann), Ke Li (Washington), Jinfeng Liu (Tsinghua), Chiara Magliocca (Geneva), Josh McFayden (CERN), Sam Meehan (CERN), Dimitar Mladenov (CERN), Mitsuhiro Nakamura (Nagoya), Toshiyuki Nakano (Nagoya), Marzio Nessi (CERN), Friedemann Neuhaus (Mainz), Laurie Nevay (Royal Holloway), Hidetoshi Otono (Kyushu), Carlo Pandini (Geneva), Hao Pang (Tsinghua), Brian Petersen (CERN), Francesco Pietropaolo (CERN), Johanna Price (UC Irvine), Markus Prim (Bonn), Michaela Queitsch-Maitland (CERN), Filippo Resnati (CERN), Hiroki Rokujo (Nagoya), Jakob Salfeld-Nebgen (CERN), Osamu Sato (Nagoya), Paola Scampoli (Bern), Kristof Schmieden (Mainz), Matthias Schott (Mainz), Anna Sfyrta (Geneva), Savannah Shively (UC Irvine), John Spencer (Washington), Yosuke Takubo (KEK), Ondrej Theiner (Geneva), Eric Torrence (Oregon), Serhan Tufanli (CERN), Benedikt Vormvald (CERN), Di Wang (Tsinghua), Gang Zhang (Tsinghua)



HELP FROM MANY OTHERS

The FASER Collaboration has received essential support from the Heising-Simons and Simons Foundations, CERN, the ATLAS SCT and LHCb Collaborations, and also many others at CERN and elsewhere

We are grateful to the ATLAS SCT project and the LHCb Calorimeter project for letting us use spare modules as part of the FASER experiment. In addition, FASER acknowledges the invaluable assistance from the CERN Physics Beyond Colliders study group; the LHC Tunnel Region Experiment (TREX) working group; the LHC Machine Committee; the LS2 Committee and the LHCC. FASER gratefully acknowledges the contributions from:

- Jonathan Gall, John Osborne (civil engineering);
- Liam Dougherty, Francisco Galan (integration);
- Pierre Thonet (magnets);
- Francesco Cerutti, Marta Sabate Gilarte (FLUKA simulation and background characterization);
- Salvatore Danzeca, Serge Chalaye (radiation measurements);
- James Storey, Swann Levasseur (beam instrumentation);
- Pierre Valentin, Tobias Dobers (survey);
- Caterina Bertone, Serge Pelletier, Frederic Delsaux (transport);
- Gael Girardot, Olivier Crespo-Lopez, Yann Maurer, Maria Papamichali (LS2 works);
- Marzia Bernardini, Anne-Laure Perrot, Katy Foraz, Markus Brugger (LHC access and schedule);
- Marco Andreini, Olga Beltramello, Thomas Otto (safety);
- Dave Robinson (ATLAS SCT), Yuri Guz (LHCb calorimeters);
- Stephen Wotton, Floris Keizer (SCT QA system and SCT readout);
- Burkhard Schmitt, Raphael Dumps, Sune Jacobsen, Giovanna Lehmann (CERN-DT contributions);
- Mike Lamont, Andreas Hoecker, Ludovico Pontecorvo, Christoph Rembser (useful discussions).

Thanks also to the CERN management for their support!

THE SIGNAL

- Nothing incoming and 2 \sim TeV, opposite-sign charged tracks pointing back to the ATLAS IP: a “light shining through (100 m-thick) wall” experiment.
- Scintillators veto incoming charged tracks (muons), and permanent dipole magnets split the charged tracks, which are detected by 3 tracking stations and a calorimeter.

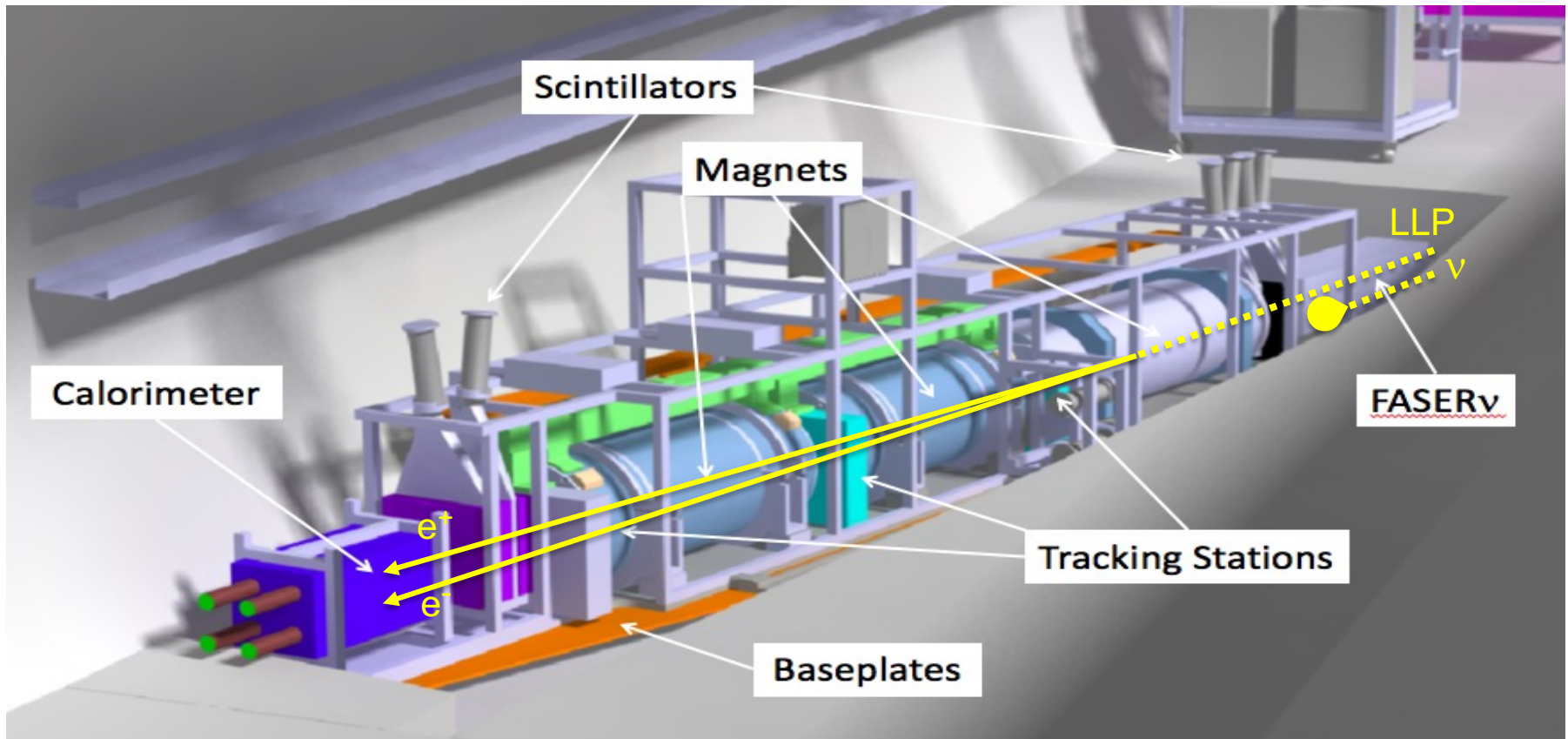

FASER IN TUNNEL T112

- The beam collision axis has been located to mm accuracy by the CERN survey department. To place FASER on this axis, a trench is required to lower the floor by 46 cm.
- The trench was completed by an Italian firm just hours before COVID shut down CERN in Spring 2020.



MAGNETS

- FASER includes 3 magnets: 1.5 m, 1 m, and 1m long.
- These magnets are 0.57 T permanent dipoles with an inner diameter of 20 cm, require little maintenance.
- Constructed by the CERN magnet group.

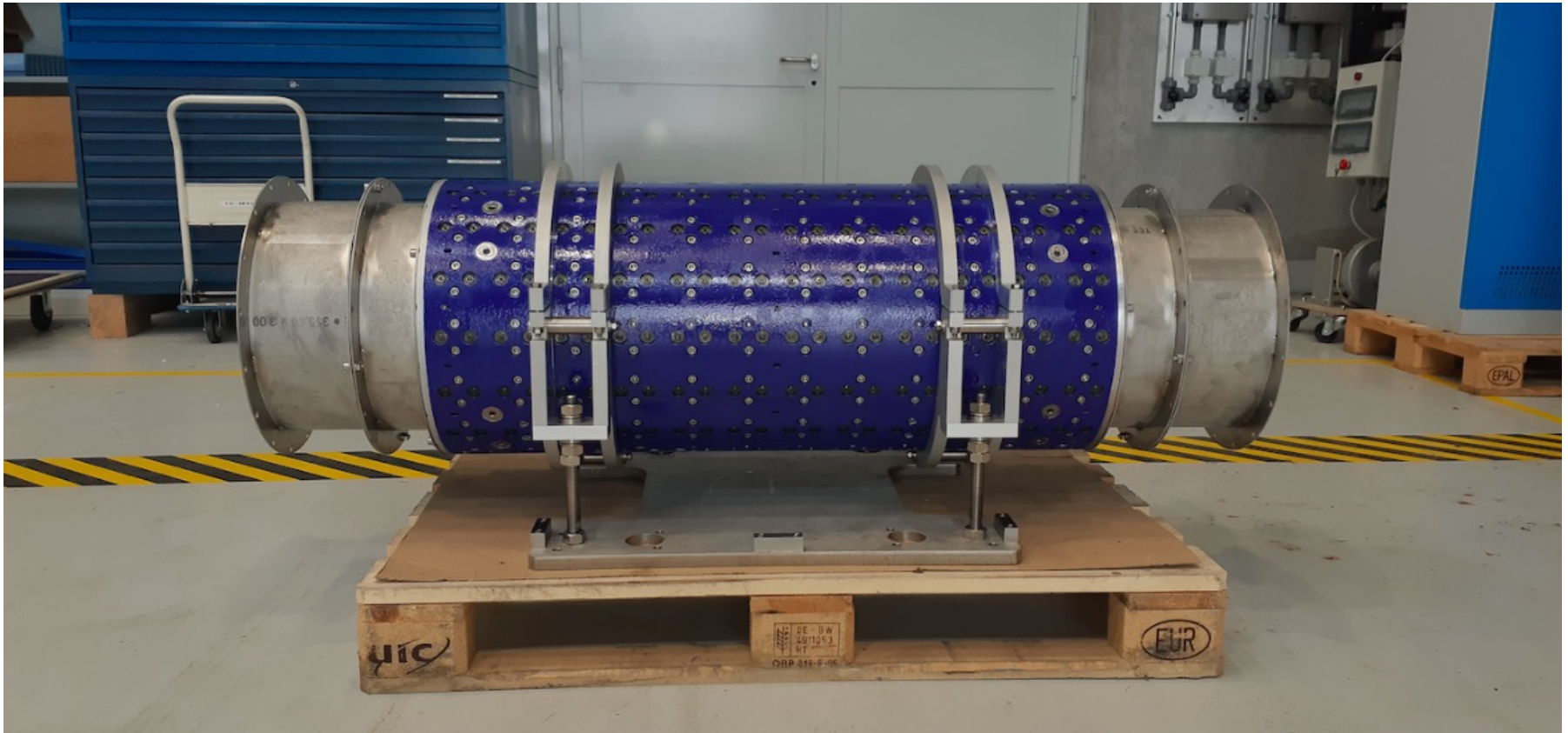

TRACKERS

- 8 ATLAS SCT modules per tracking plane, 3 tracking planes per tracking station, 3 tracking stations at FASER.

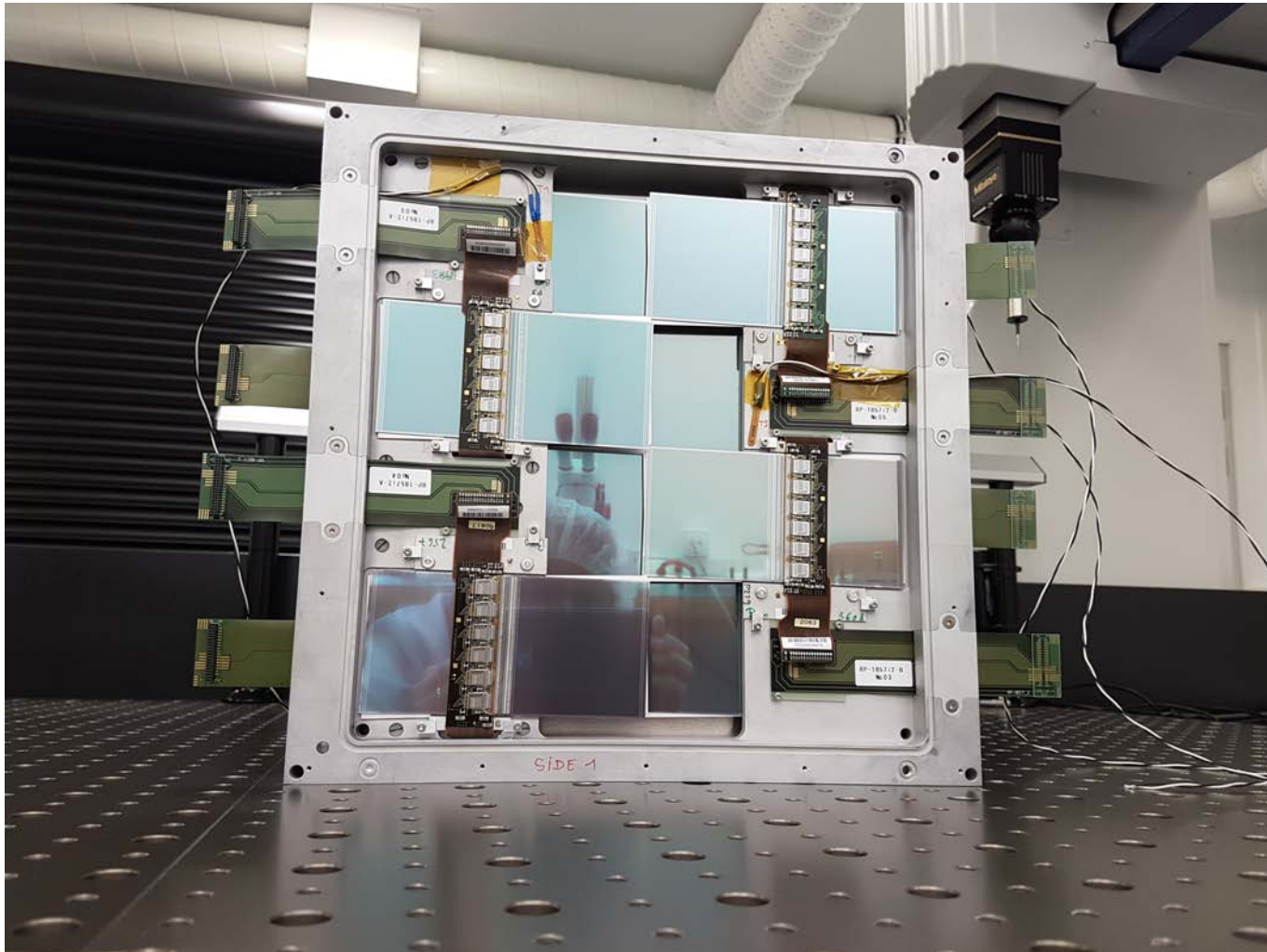

SCINTILLATORS

- 4 veto scintillators, each 2cm x 30cm x 30cm, upstream of the detector. Efficiency of each one is $> 99.99\%$, which, barring correlations, reduces muon background to negligible levels.
- Additional beam backgrounds, simulated with FLUKA and validated with pilot detectors in 2018, are also expected to be negligible.



FASER INSTALLATION

Dougherty, CERN Integration (2019)

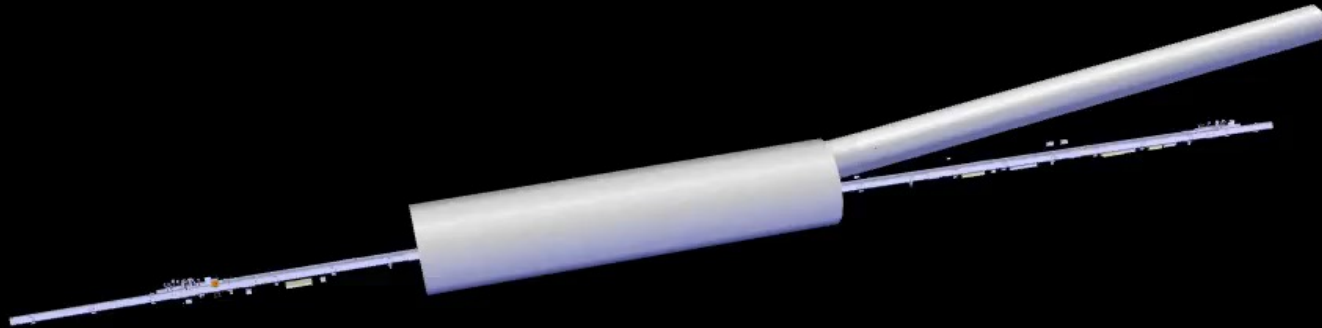

FASER CURRENT STATUS

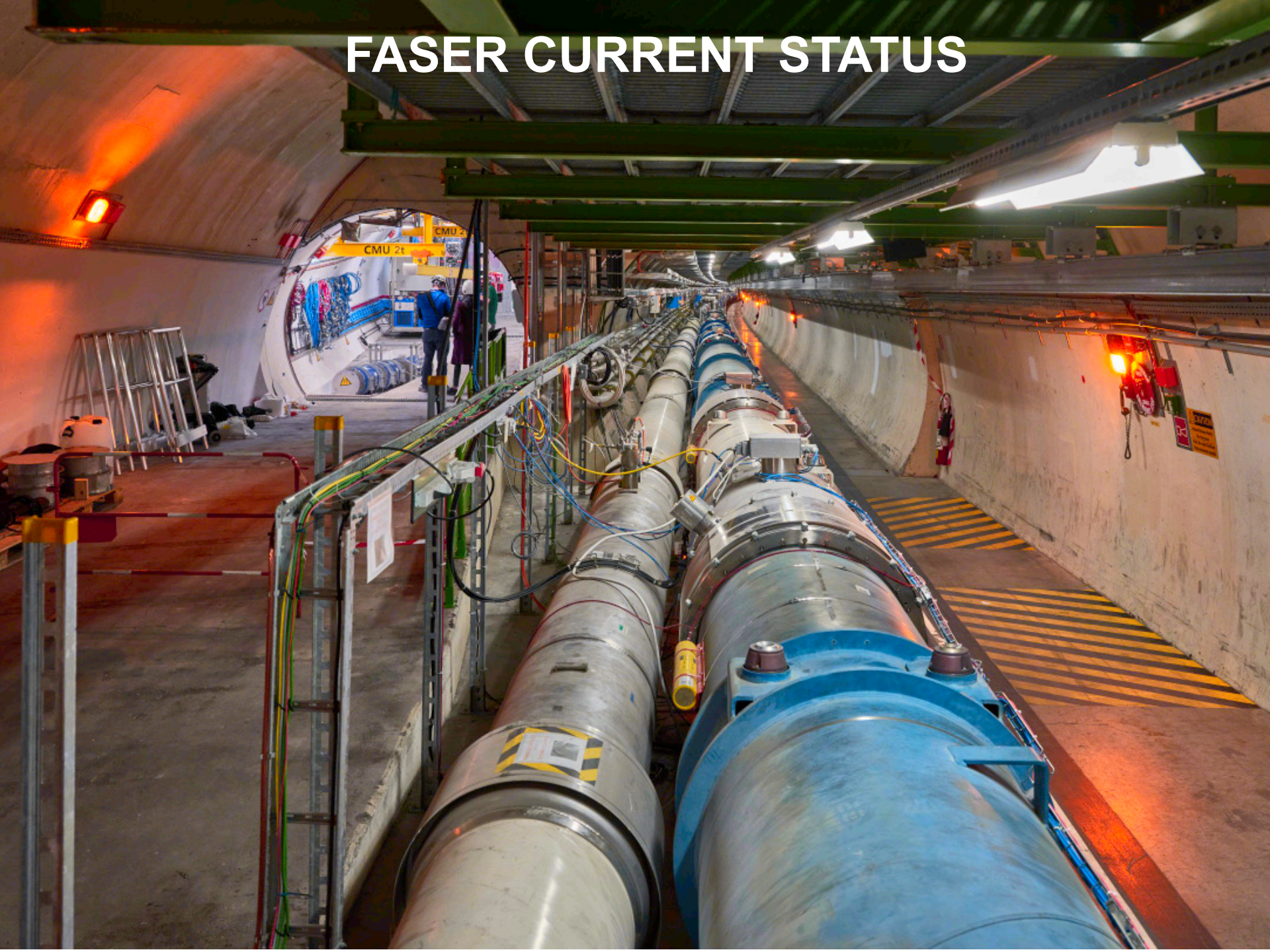

FASER CURRENT STATUS

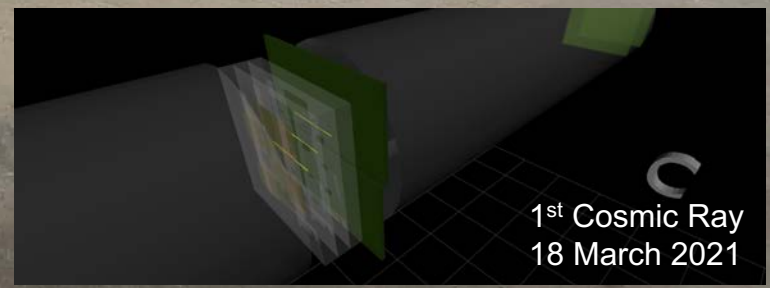
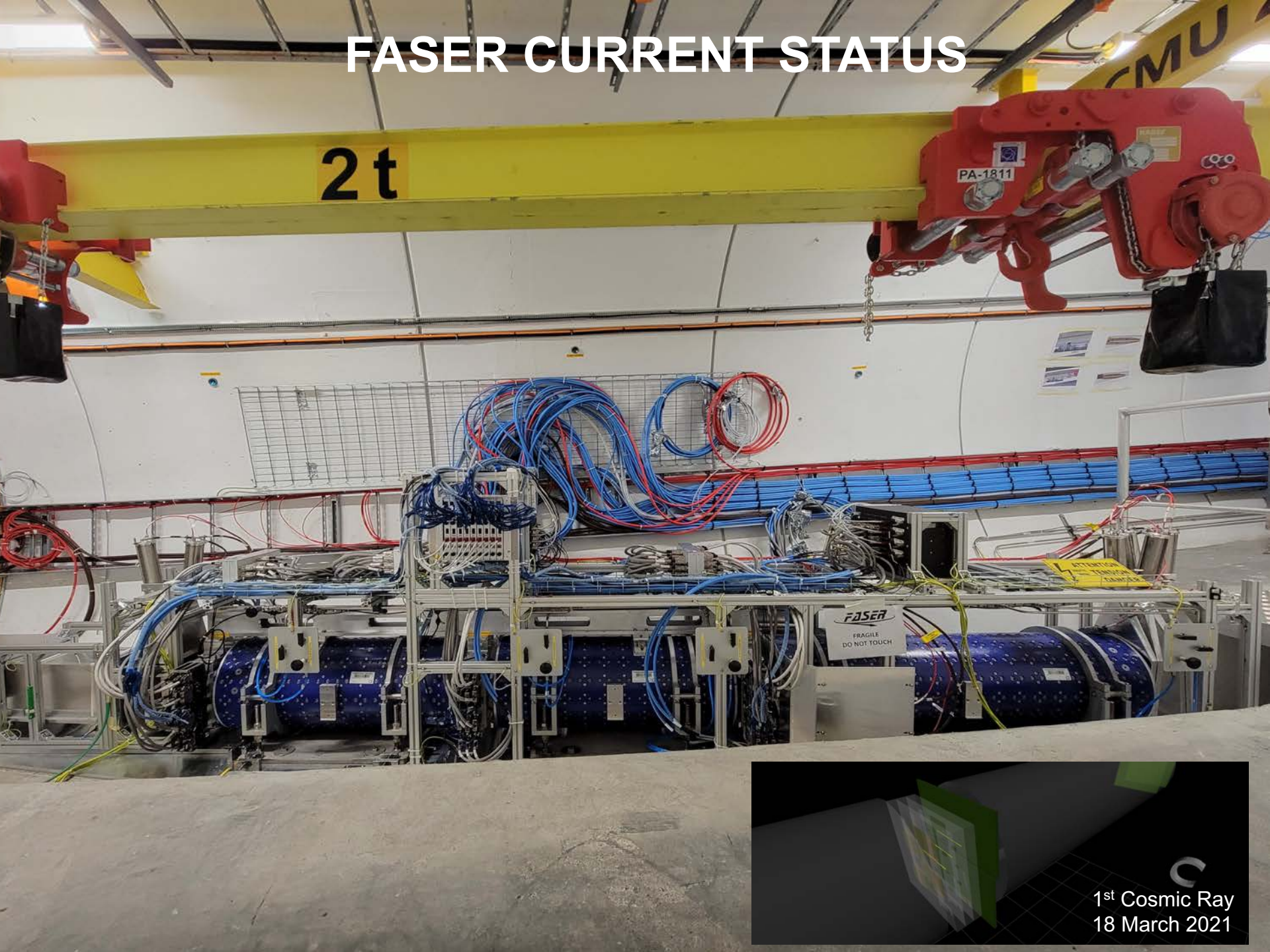

1st Cosmic Ray
18 March 2021

DARK PHOTON SENSITIVITY REACH

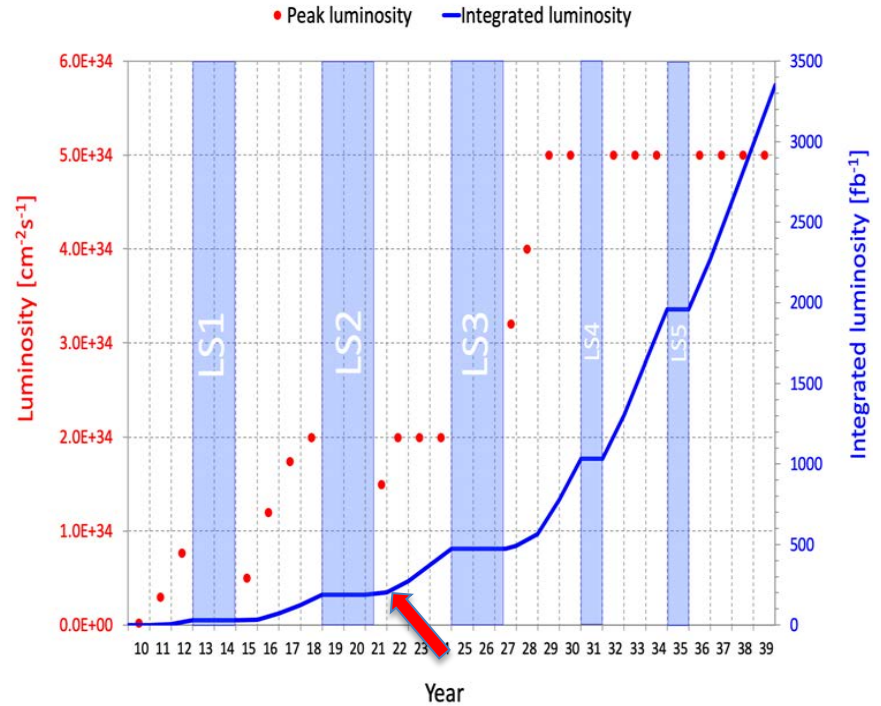
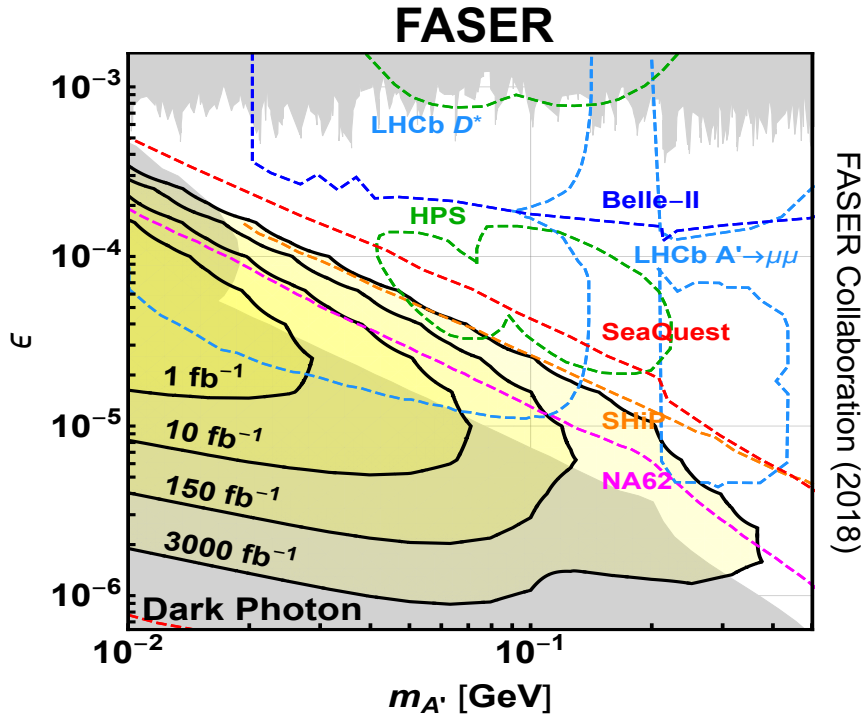

- FASER probes new parameter space with just 1 fb^{-1} starting in 2022.
- Without upgrade, HL-LHC extends ($L \cdot Volume$) by factor of 3000; possible upgrade to FASER 2 ($R = 1m$, $L = 10m$) extends ($L \cdot Volume$) by factor of $\sim 10^6$.

PHYSICS SUMMARY

- Many other models have also be studied: FASER has discover prospects for many of the Physics Beyond Colliders Benchmark Cases; see 1811.12522.

Benchmark Model	FASER	FASER 2	References
V1/BC1: Dark Photon	√	√	Feng, Galon, Kling, Trojanowski, 1708.09389
V2/BC1': $U(1)_{B-L}$ Gauge Boson	√	√	Bauer, Foldenauer, Jaeckel, 1803.05466 FASER Collaboration, 1811.12522
BC2: Invisible Dark Photon	–	–	–
BC3: Milli-Charged Particle	–	–	–
S1/BC4: Dark Higgs Boson	–	√	Feng, Galon, Kling, Trojanowski, 1710.09387 Batell, Freitas, Ismail, McKeen, 1712.10022
S2/BC5: Dark Higgs with hSS	–	√	Feng, Galon, Kling, Trojanowski, 1710.09387
F1/BC6: HNL with e	–	√	Kling, Trojanowski, 1801.08947 Helo, Hirsch, Wang, 1803.02212
F2/BC7: HNL with μ	–	√	Kling, Trojanowski, 1801.08947 Helo, Hirsch, Wang, 1803.02212
F3/BC8: HNL with τ	√	√	Kling, Trojanowski, 1801.08947 Helo, Hirsch, Wang, 1803.02212
A1/BC9: ALP with photon	√	√	Feng, Galon, Kling, Trojanowski, 1806.02348
A2/BC10: ALP with fermion	√	√	FASER Collaboration, 1811.12522
A3/BC11: ALP with gluon	√	√	FASER Collaboration, 1811.12522

FASER_v

COLLIDER NEUTRINOS

- In addition to the possibility of hypothetical new light, weakly-interacting particles, there are also known light, weakly-interacting particles: neutrinos.
- But the high-energy ones, which interact most strongly, are overwhelmingly produced in the far forward direction, and escape all existing detectors. **No collider neutrino has ever been detected.**
 - If they can be detected, there is a rich SM physics program: all flavors are produced ($\pi \rightarrow \nu_\mu$, $K \rightarrow \nu_e$, $D \rightarrow \nu_\tau$) and both neutrinos and anti-neutrinos.

De Rujula, Ruckl (1984); Winter (1990)

FASER Collaboration (2019); Bai, Diwan, Garzelli, Jeong, Reno (2020)

- Currently two experiments targeting this opportunity: FASER ν , to be located just in front of FASER in TI12, and SND, proposed for the opposite side of ATLAS in TI18.

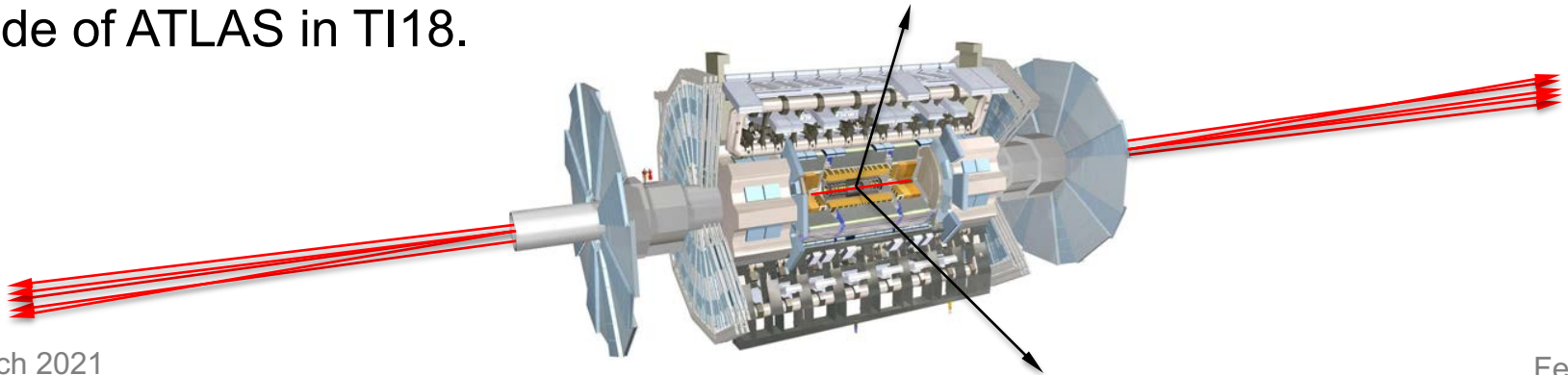

NEUTRINO FLUXES

- In fact, we have probably already seen our first TeV collider neutrino.
- In 2018 a 29 kg FASER pilot emulsion detector collected 12.5 fb^{-1} on the beam collision axis (installed and removed during Technical Stops).
- Expect ~ 10 neutrino interactions. Several neutral vertices identified, likely to be neutrinos. Analysis ongoing.

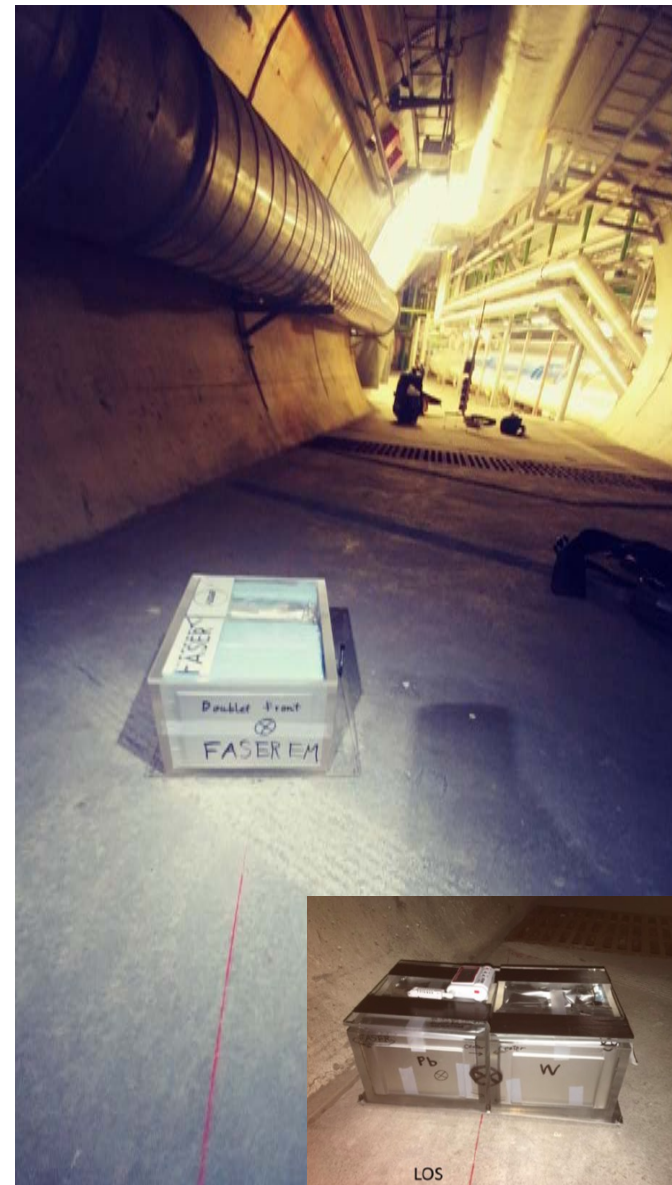
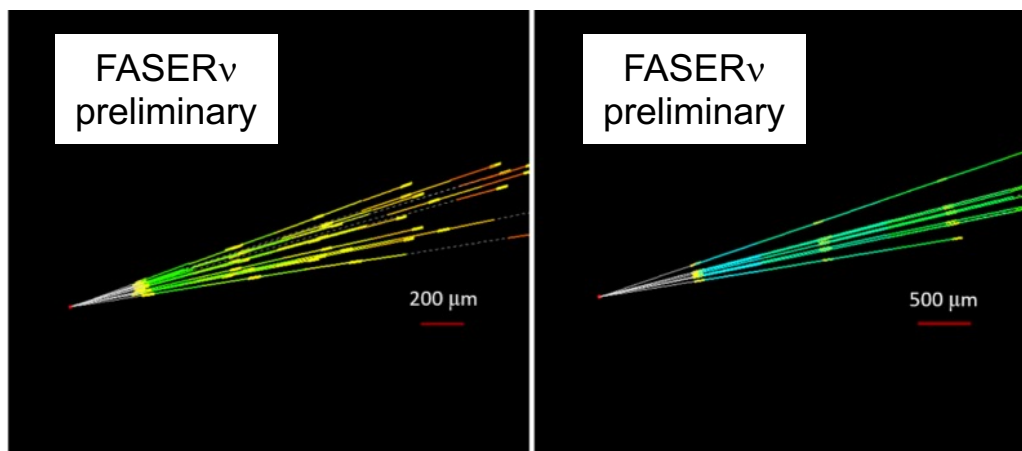

THE FASER _{ν} DETECTOR

- FASER _{ν} is designed to detect neutrinos of all flavors.
 - 25cm x 30cm x 1.1m detector consisting of 770 emulsion layers interleaved with 1mm-thick tungsten plates; target mass = 1.1 tonne.
 - Emulsion swapped out every $\sim 10\text{-}30 \text{ fb}^{-1}$, total 10 sets of emulsion for Run 3.

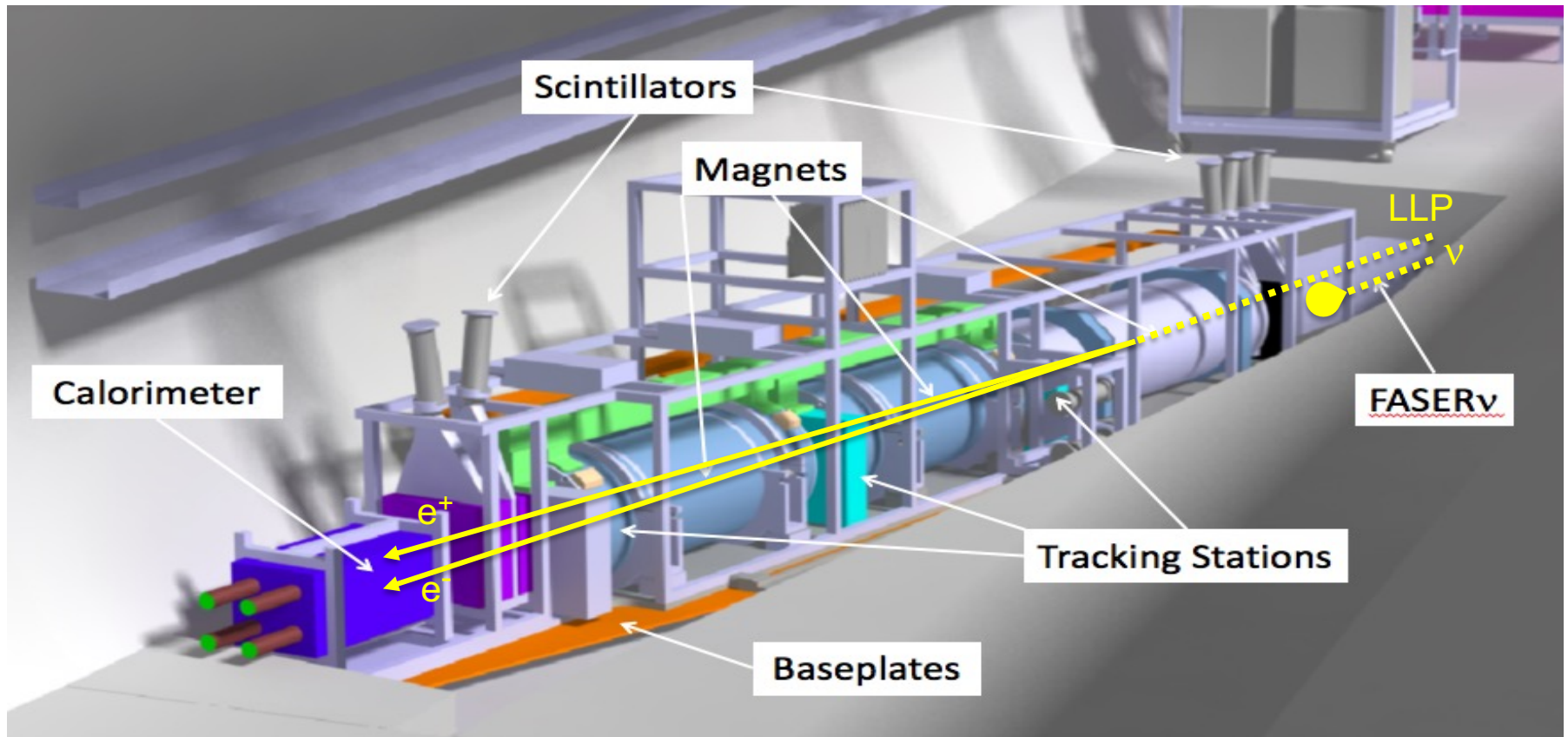

NEUTRINO PHYSICS

- In Run 3 (2022-24), FASER ν will
 - Detect the first collider neutrino.
 - Record ~ 1000 ν_e , $\sim 10,000$ ν_μ , and ~ 10 ν_τ interactions at TeV energies, the first direct exploration of this energy range for all 3 flavors.
 - Double the world's supply of tau neutrinos.
 - Distinguish muon neutrinos from anti-neutrinos by combining FASER and FASER ν data, and so measure their cross sections independently.

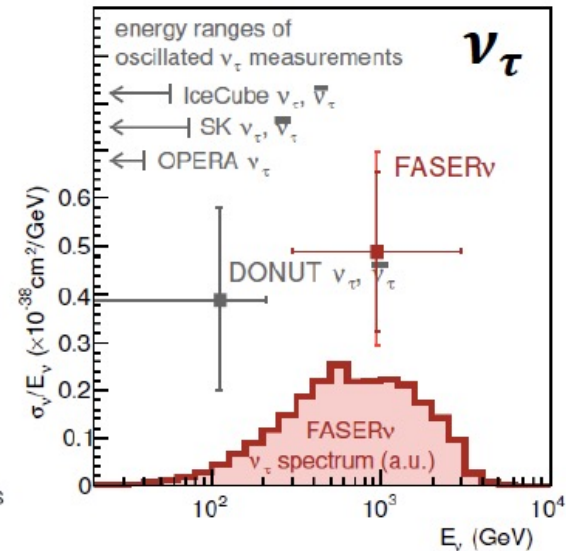
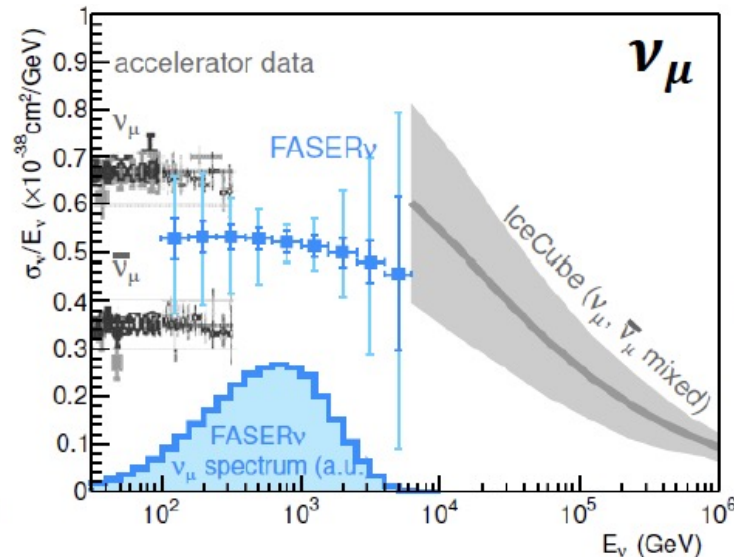
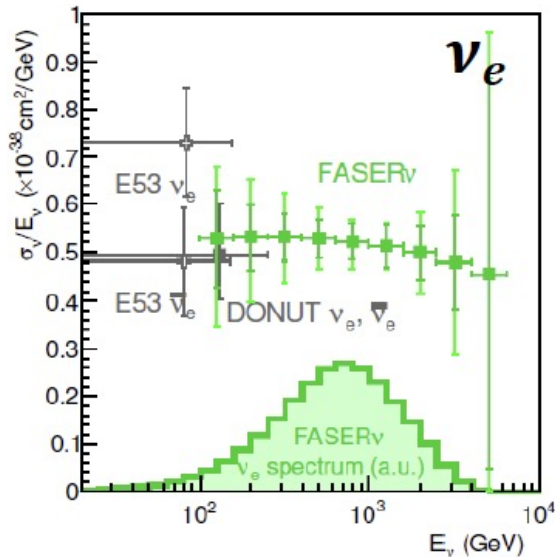

FASER Collaboration 1908.02310 (2019)

QCD PHYSICS

- The forward production of hadrons is currently subject to large uncertainties. Forward ν experiments will provide useful insights.
 - On- and off-axis neutrino detectors provide complementary information ($\pi \rightarrow \nu_\mu$, $K \rightarrow \nu_e$, $D \rightarrow \nu_\tau$).
 - Different target nuclei (lead, tungsten) probe different nuclear pdfs.
 - Strange quark pdf through $\nu s \rightarrow lc$.
 - Forward charm production, intrinsic charm.
 - Refine simulations that currently vary greatly (EPOS-LHC, QGSJET, DPMJET, SIBYLL, PYTHIA...).
 - Provide essential input to astroparticle experiments; e.g., distinguish galactic neutrino signal from atmospheric neutrino background at IceCube.

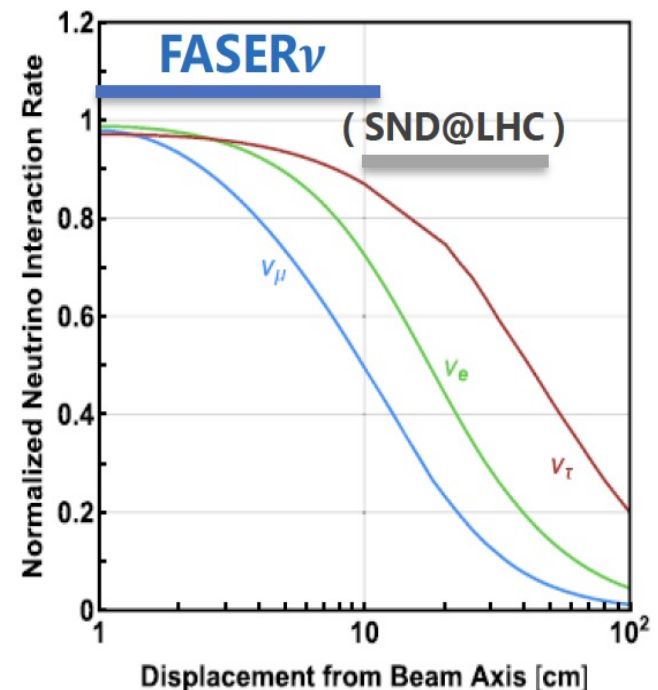

FORWARD PHYSICS FACILITY

FORWARD PHYSICS FACILITY

- FASER, FASER_v, and other proposed far-forward detectors are currently highly constrained by 1980's infrastructure that was never intended to support experiments.
- At the same time, it is becoming clear that there is a rich physics program in the far-forward region.
 - New particle searches, neutrinos, QCD, MC event generators, milli-charged particles, dark matter, dark sector, cosmic neutrinos, ...
- Strongly motivates creating a dedicated facility to house far-forward experiments for the HL-LHC era from 2027-37.
 - Snowmass LOI: 240 authors from many different communities
 - FPF Kickoff Meeting: 9-10 Nov 2020, <https://indico.cern.ch/event/955956>, organized with Maria Garzelli and Felix Kling.
 - 2nd FPF Workshop: 27-28 May 2021, <https://indico.cern.ch/event/1022352>, announcement and talk solicitation coming soon.

FPF LOCATION

Possibilities under active investigation: enlarge existing cavern UJ12, 480 m from ATLAS and shielded from the ATLAS IP by ~100 m of rock; or create a new shaft and cavern ~612 m from ATLAS past UJ18.

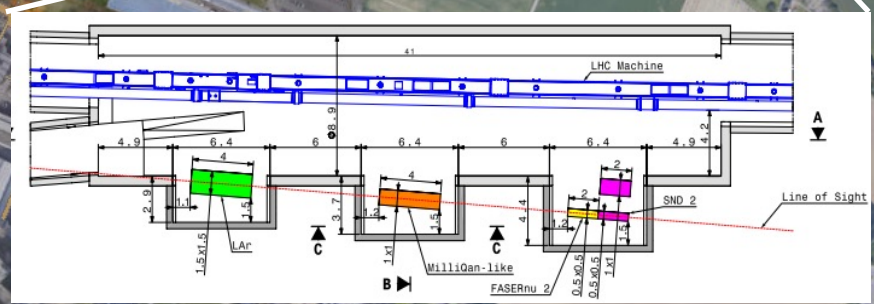
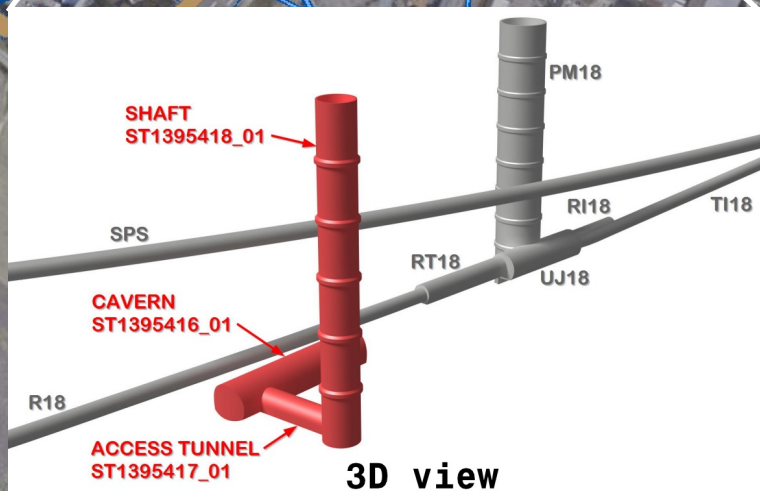
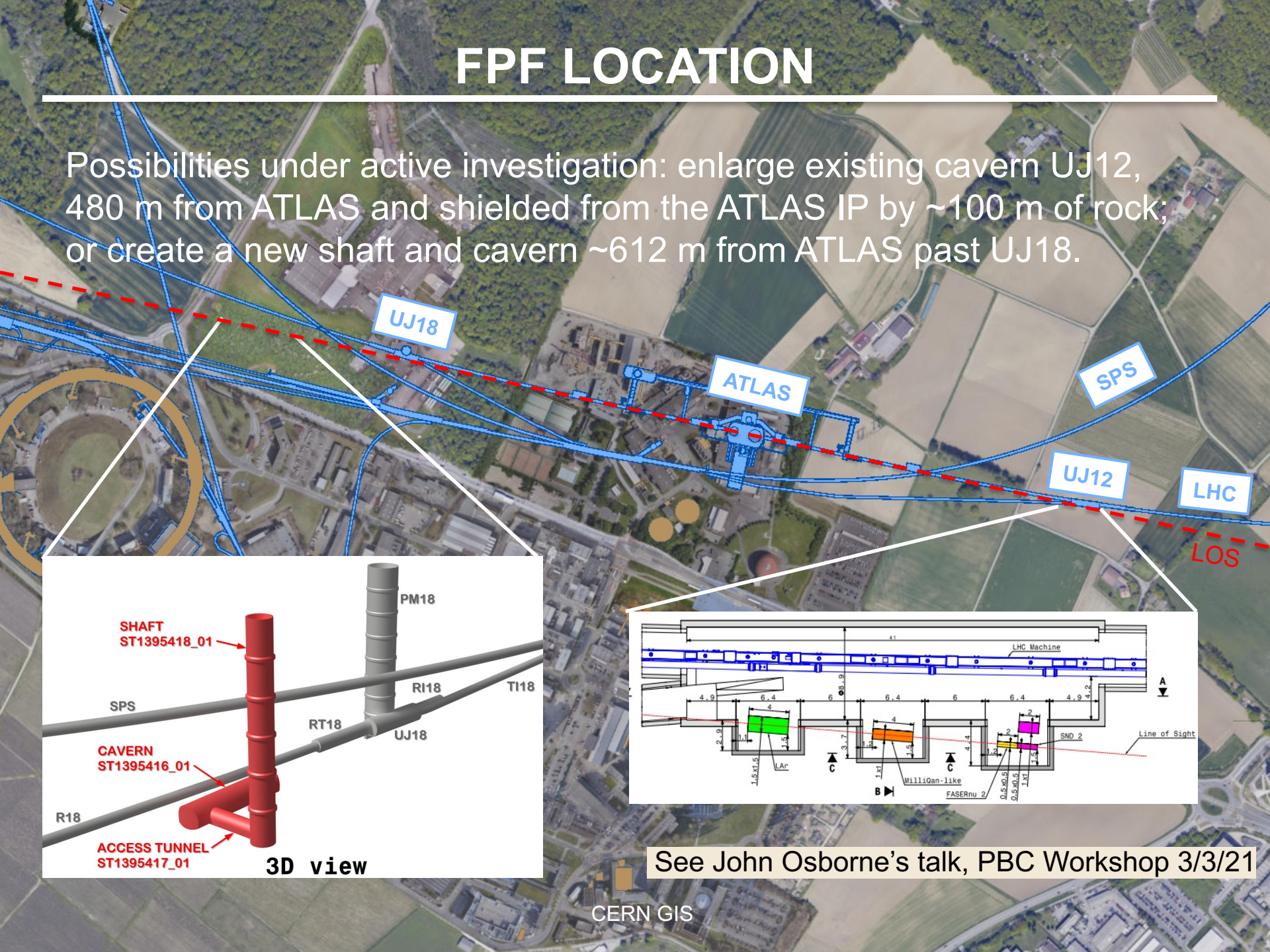

See John Osborne's talk, PBC Workshop 3/3/21

FPF: NEW SHAFT AND CAVERN

- Many advantages
 - Construction access far easier
 - Access possible during LHC operations
 - Size and length of cavern more flexible
 - Designed around needs of the experiments

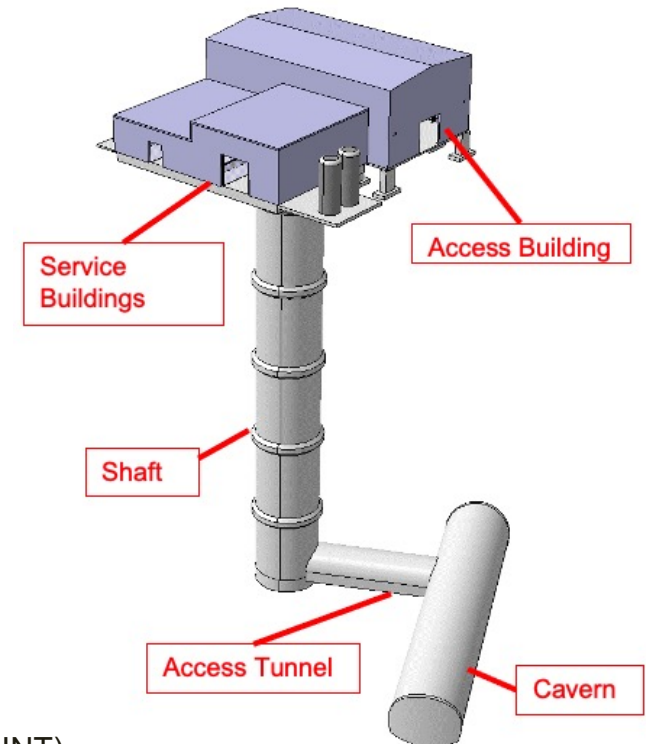
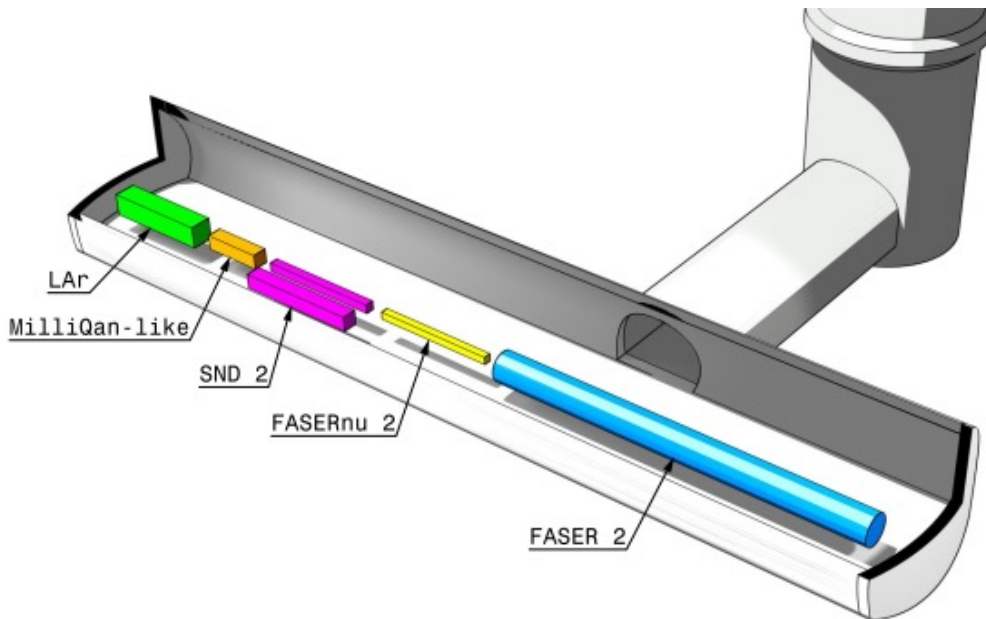
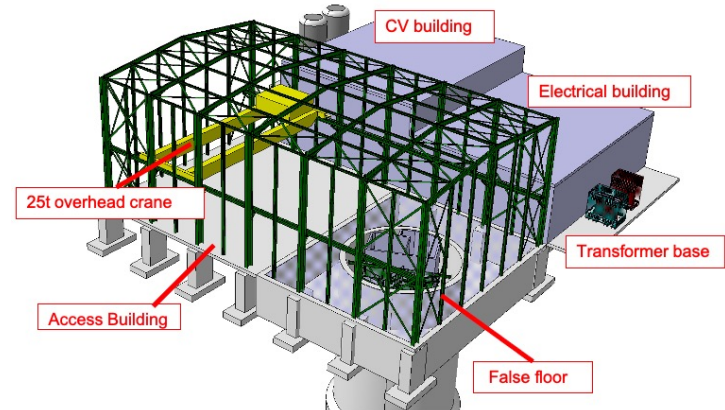

NEW PHYSICS SEARCHES AT THE FPF

- The FPF will house a number of experiments
- FASER 2, an upgraded FASER with $R = 1$ m, $L = 10$ m, can discover all candidates with renormalizable couplings (dark photon, dark Higgs, HNL); ALPs with all types of couplings (γ , f , g); and many other particles.
- Other experiments can probe neutrinos and many other interesting ideas.

Benchmark Model	Underway	FPF
BC1: Dark Photon	FASER	FASER 2
BC1': $U(1)_{B-L}$ Gauge Boson	FASER	FASER 2
BC2: Dark Matter	–	FLArE
BC3: Milli-Charged Particle	–	FORMOSA
BC4: Dark Higgs Boson	–	FASER 2
BC5: Dark Higgs with hSS	–	FASER 2
BC6: HNL with e	–	FASER 2
BC7: HNL with μ	–	FASER 2
BC8: HNL with τ	FASER	FASER 2
BC9: ALP with photon	FASER	FASER 2
BC10: ALP with fermion	FASER	FASER 2
BC11: ALP with gluon	FASER	FASER 2

FLArE

DARK MATTER AT THE FPF

Batell, Feng, Trojanowski (2021)

- If $m_{\text{LLP}} > 2m_{\text{DM}}$, the LLP will typically decay in the dark sector to dark matter, leading to invisible decays.

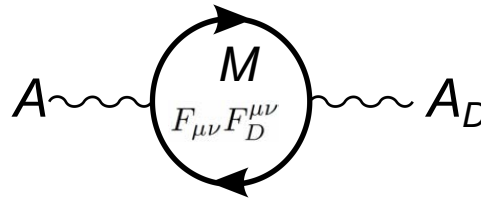
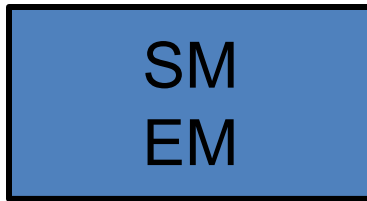

- This makes the signal much more difficult to find, but opens the possibility of detecting **dark matter**, not just dark portals.
- It implies an intense beam of DM particles in the far-forward direction. Can look for the resulting DM to scatter off electrons and nuclei in a detector at the FPF.

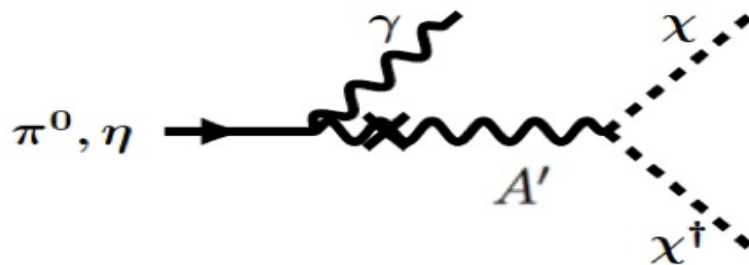

DM production

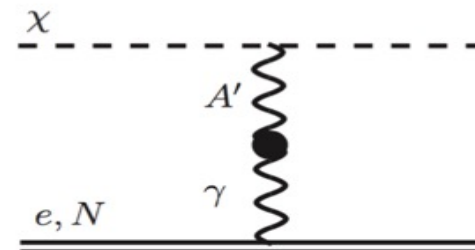

DM scattering

FLArE: FORWARD LIQUID ARGON EXPERIMENT

- LAr detectors are now well-known for detecting neutrinos and dark matter. They have also been discussed specifically in this context of detecting dark matter produced by accelerators and colliders.

Batell, Pospelov, Ritz (2009); MiniBooNE (2017); SND@LHC (2020)

- Consider two possible detectors placed on the beamline, ~ 500 m from the IP, running throughout the HL-LHC era with 3 ab^{-1} .
 - FLArE-10: 10-tonne detector, 1m x 1m x 7m
 - FLArE-100: 100-tonne detector, 1.6m x 1.6m x 30m

- Focus here on the electron scattering signal. Main backgrounds are from νe scattering, and νN scattering.

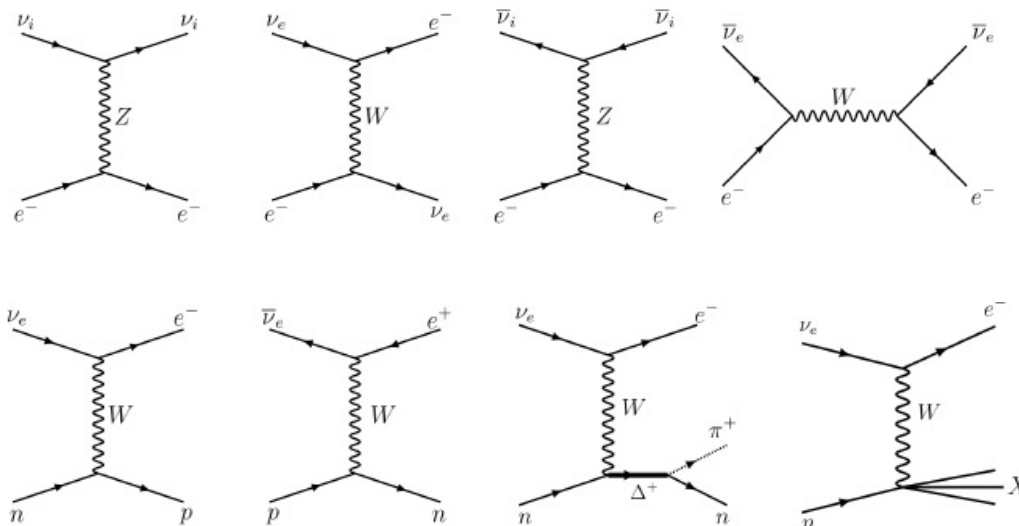

- Note: νN scattering and lots of interesting neutrino physics yet to be explored!**

FLArE: FORWARD LIQUID ARGON EXPERIMENT

- DM-e scattering is suppressed by ϵ , but also highly enhanced by a light mediator.
- The DM-e cross section can be bigger than the SM ν -e cross section, and the resulting energy spectrum is softer.
- The search benefits greatly from the low energy threshold of LAr detectors. Assuming electrons can be detected down to 30 MeV, reject events with additional charged tracks above this threshold, νe background can be reduced to ~ 10 , νN reduced to even lower levels.

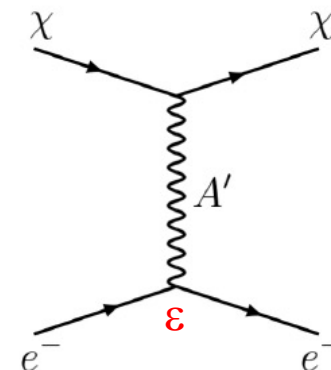
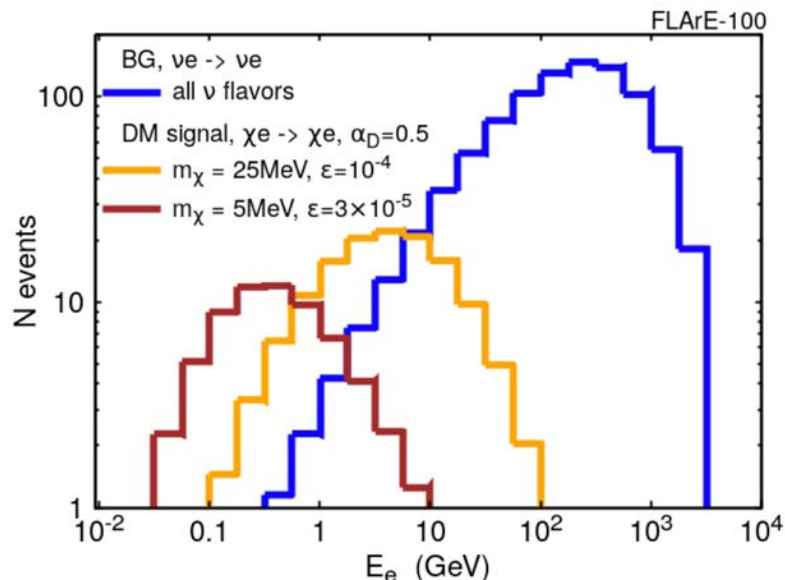

Electron recoil energy	$30 \text{ MeV} < E_e < 20 \text{ GeV}$
Electron recoil angle	$\theta_e < 30 \text{ mrad}$ for $E_e > 3 \text{ GeV}$ no θ_e cut for $E_e \leq 3 \text{ GeV}$
Track visibility	no additional charged tracks with $p > 30 \text{ MeV}$

FLArE: SENSITIVITY REACHES

- FLArE will probe much of the favored/allowed relic target region.
- Complementary to missing energy, missing momentum experiments that probe the “too large $\Omega_\chi h^2$ ” region, but don’t detect DM scattering.

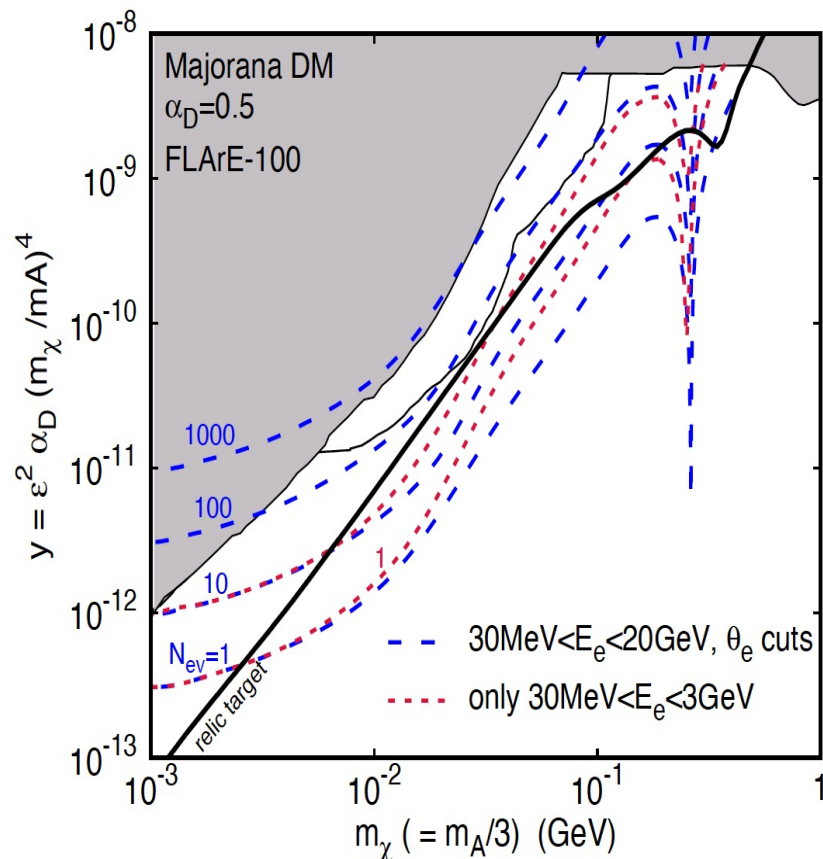
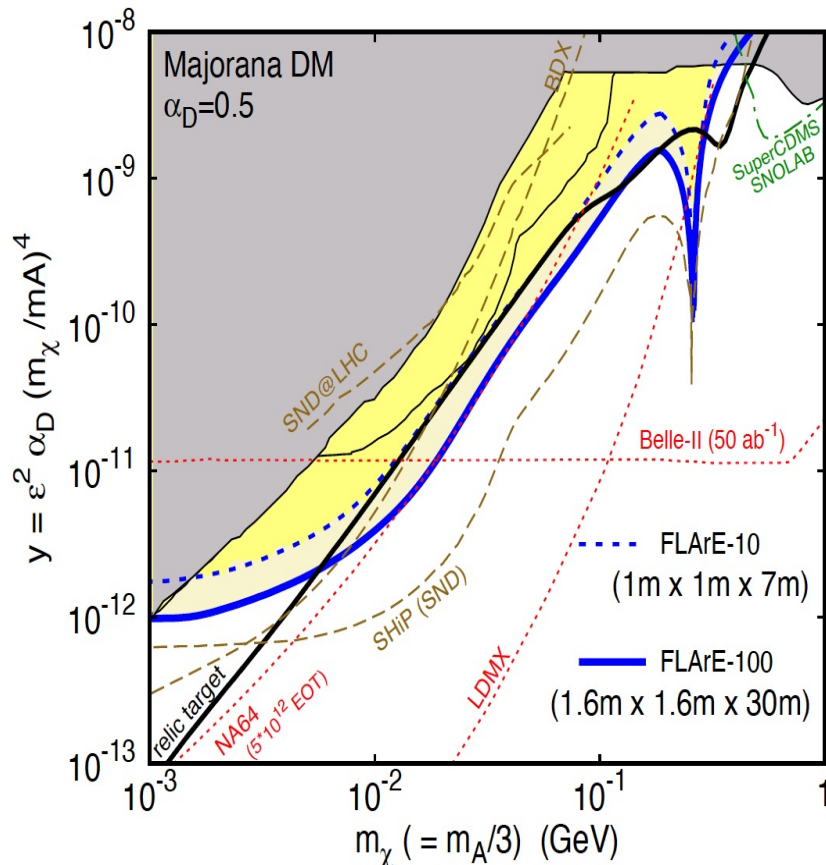

Batell, Feng, Trojanowski (2021)

SUMMARY

SUMMARY

- New target for discovery: neutrinos and light and weakly-interacting particles probed by fast, small, cheap experiments in the far-forward region of the LHC.
- FASER and FASER ν : 3.5 years from theory proposal to completion, 5 m long, ~\$2M. Data-taking starts in 2022 with a rich physics program.
 - BSM: searches for dark photons, HNLs, ALPs, new forces.
 - SM: opens the new field of LHC neutrino physics. $\sim 1000 \nu_e$, $\sim 10,000 \nu_\mu$, $\sim 10 \nu_\tau$ at TeV energies. Implications for neutrino properties, forward hadron production, cosmic ray and cosmic neutrino physics.
- Forward Physics Facility: Proposed facility to house a suite of far-forward experiments for the HL-LHC era from 2027-37.
- FLArE: Forward Liquid Argon Experiment, proposed 10-100 tonne LArTPC for dark matter searches, neutrino physics.