



Electron Cyclotron Current Drive in DEMO Plasmas

Emanuele Poli¹, Mattia Siccino¹, Antti Snicker², Chuanren Wu³, Hartmut Zohm¹

¹Max-Planck-Institut für Plasmaphysik, Garching bei München, Germany

²VTT, Helsinki, Finland

³Karlsruhe Institute for Technology, Karlsruhe, Germany



This work has been carried out within the framework of the EUROfusion Consortium, funded by the European Union via the Euratom Research and Training Programme (Grant Agreement No 101052200 — EUROfusion). Views and opinions expressed are however those of the author(s) only and do not necessarily reflect those of the European Union or the European Commission. Neither the European Union nor the European Commission can be held responsible for them.

Outline

- The European DEMO and the role of Electron Cyclotron waves
- Theoretical background: resonance condition and Electron Cyclotron Current Drive (ECCD) efficiency
- ECCD for bulk current drive → how to optimize the ECCD efficiency
- ECCD for stabilization of neoclassical tearing modes → different requirements as compared to bulk current drive
- Recent developments (wave scattering, thermal instability, extraordinary-mode injection)

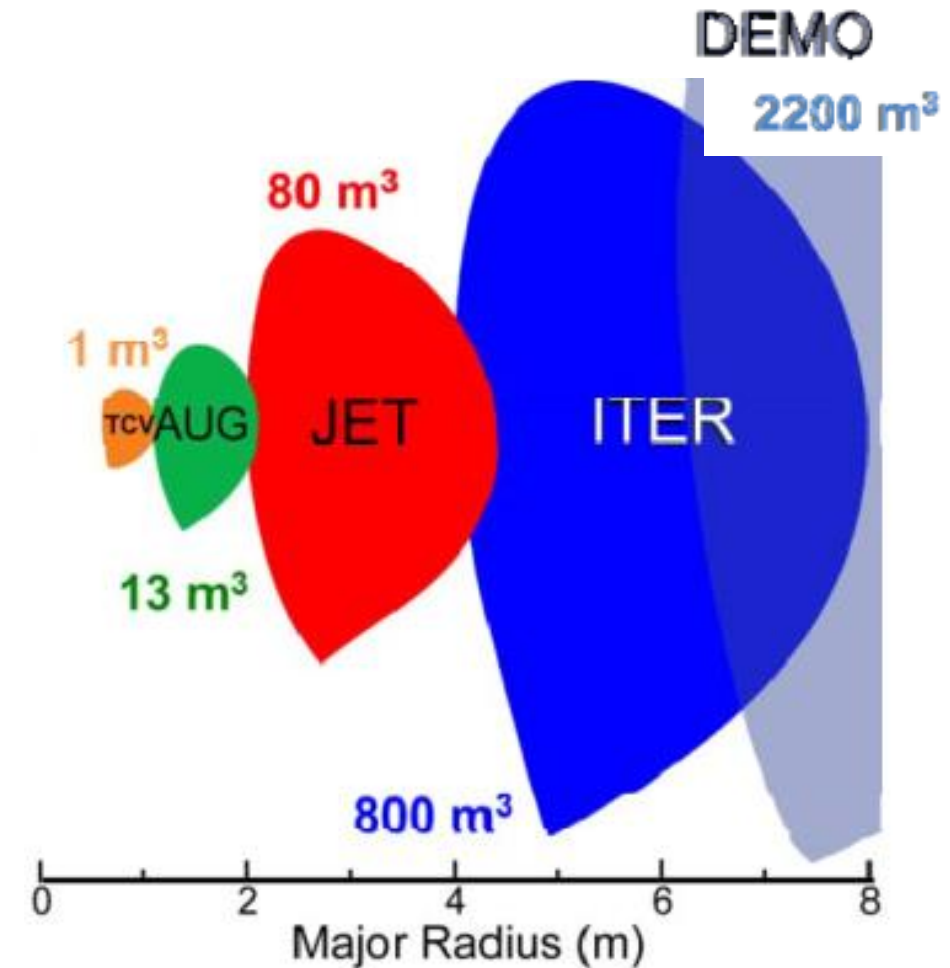

[Ciattaglia 17]

Outline

- The European DEMO and the role of Electron Cyclotron waves
- Theoretical background: resonance condition and ECCD efficiency
- ECCD for bulk current drive → how to optimize the ECCD efficiency
- ECCD for stabilization of neoclassical tearing modes → different requirements with respect to bulk current drive
- Recent developments (wave scattering, thermal instability, extraordinary-mode injection)

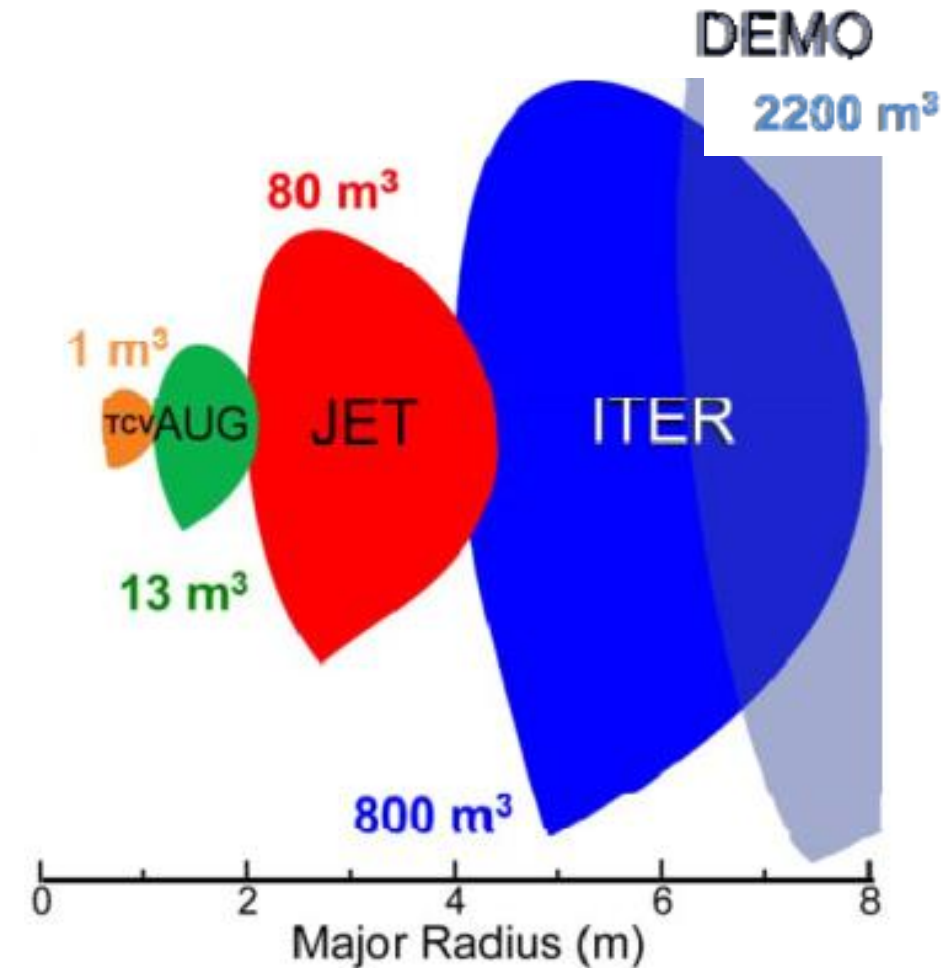



The European DEMO [Fus. Eng. Des., Special Issue, 2022]

- “DEMO is the **nearest-term reactor design to follow ITER**” which means for the development strategy “**modest extrapolation** from the ITER physics & technology basis” [Ciattaglia 17; Federici 21]
- DEMO aims to **demonstrate the production of net electricity** (ca. 500 MW i.e. ca. 2 GW fusion power), **tritium self-sufficiency** and the adoption of maintenance systems capable of achieving **adequate plant availability**
- The present design point is a **trade-off between the most mature knowledge in physics and technology**, the emphasis on the problem of the **power exhaust** and the attention given to **nuclear design integration**, and “not an a priori desire to be big”

One (recent) possible incarnation...

Major and minor radius, R, a [m, m]	9.0, 2.9
Aspect ratio, A	3.1
Field on axis, B_0 [T]	5.86
Plasma safety factor, q_{95}	3.89
Triangularity, elongation, δ_{95}, κ_{95}	0.33, 1.65
Plasma current, I_p [MA]	17.75
Non-inductive current fraction, f_{NI}	0.39
Driven current fraction, f_{CD}	< 0.05
Fusion power, P_{fus} [MW]	2000
Power across separatrix, P_{sep} [MW]	170.4
LH threshold power, P_{LH} [MW]	120.8
Confinement H-factor, H_{98}	0.98
Electron density, $\langle n \rangle / n_{GW}$	1.2
Average temperature, $\langle T \rangle$ [keV]	12.49
Normalised beta, β_N [% mT/MA]	2.5
Z_{eff}	2.12
$P_{sep}B/q_{95}AR$ [MW T/m]	9.2
P_{sep}/R [MW/m]	18.9
Pulse length [sec]	7200

[Kembleton 22]



Electron Cyclotron Waves

- Electron Cyclotron (EC) waves are routinely used in magnetically confined plasmas for **heating and current drive** and as a **diagnostic tool** (passive and active)
- Typical frequencies: $\Omega_e = eB/mc \rightarrow \nu_e = \Omega_e/2\pi$ [GHz] $\sim 28 \times B$ [T] (**ITER EC system: 170 GHz**)
- **Advantages** of EC waves:
 - EC waves propagate also in the limit of vanishing density (vacuum) \rightarrow no coupling issue
 - Absorption location tuneable, narrow deposition profiles possible \rightarrow “surgical” applications
 - Complete absorption for a proper choice of frequency and polarization
 - Well-collimated beams injected \rightarrow require small apertures in the vacuum vessel \rightarrow easier neutron shielding, small impact on tritium breeding
 - In general, mature theoretical, experimental and technological knowledge for fusion devices
- **Disadvantages** of EC waves:
 - Expensive 1-2 MW, >100 GHz sources, more prone to failure than sources for waves in other frequency ranges
 - No sources yet above ca. 200 GHz
 - ECCD efficiency might be too low for steady state operation \rightarrow see later

Electron Cyclotron System in ITER

ITER equatorial EC launcher

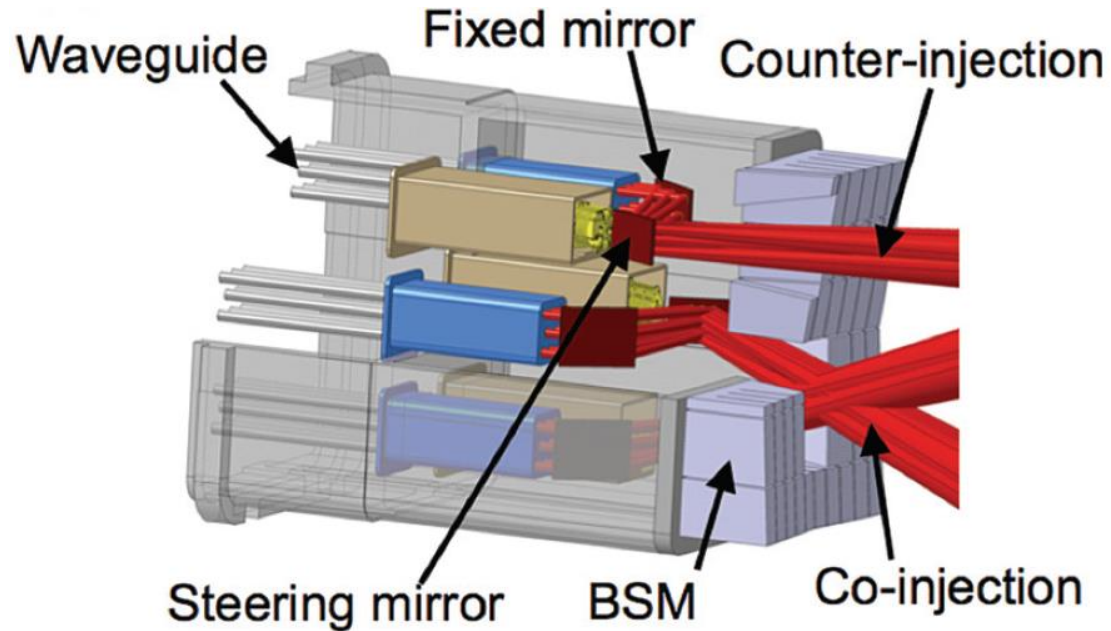

[Henderson 15]

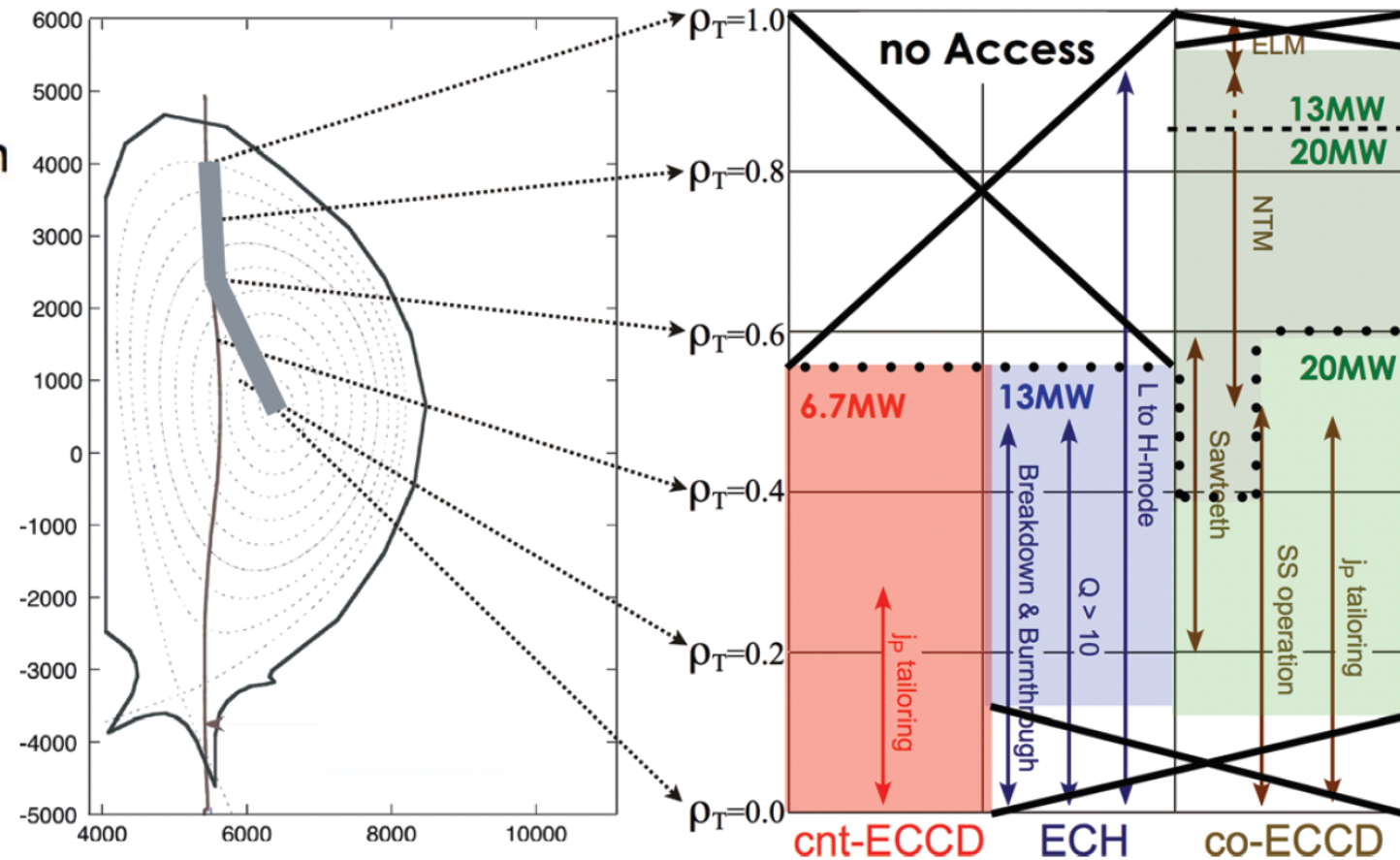

- EC system foreseen for **a variety of applications in ITER** ← requires **flexible design**
- **DEMO will require less flexibility** in terms of targeted applications and possible plasma scenarios

Electron Cyclotron System in DEMO

- Different options explored in the last years, including **steady-state plasma scenarios** → **high recirculating power** required to sustain the plasma current non-inductively
- Present design **focus on a pulsed machine** (2h), no need for bulk current drive
- Electron cyclotron heating & current drive mostly for breakdown, ramp control, **bulk heating** [poster Ch. Tsironis], **NTM control**, and **radiative-instability control**

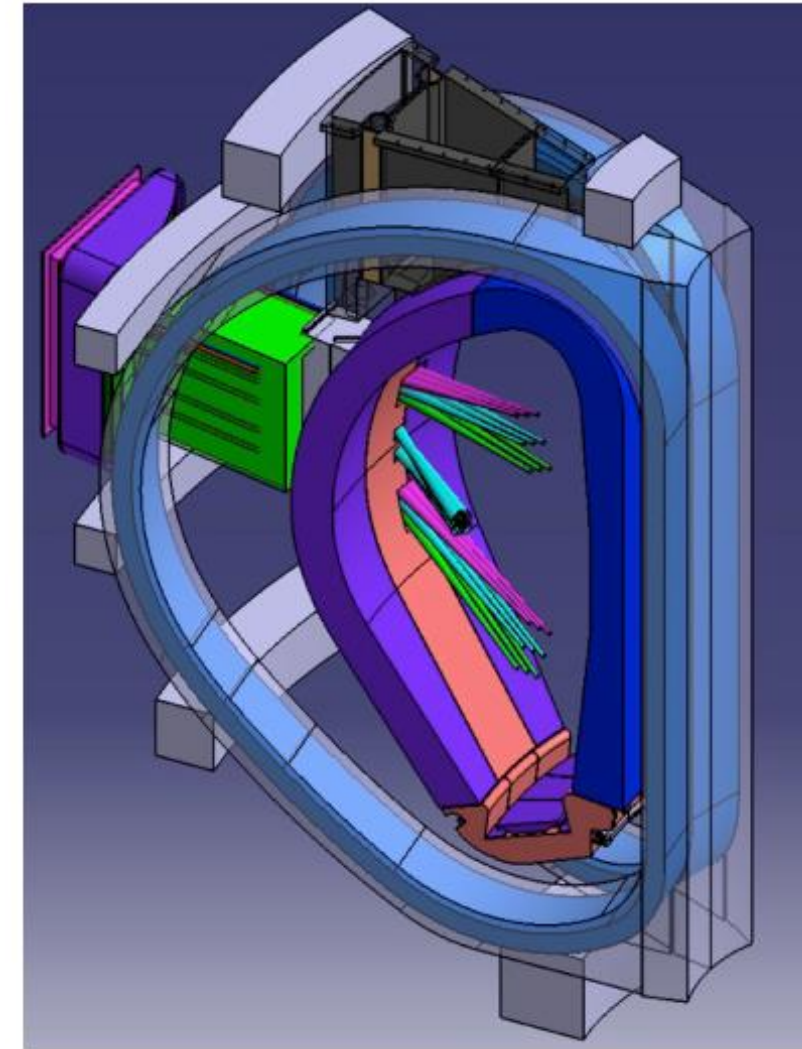
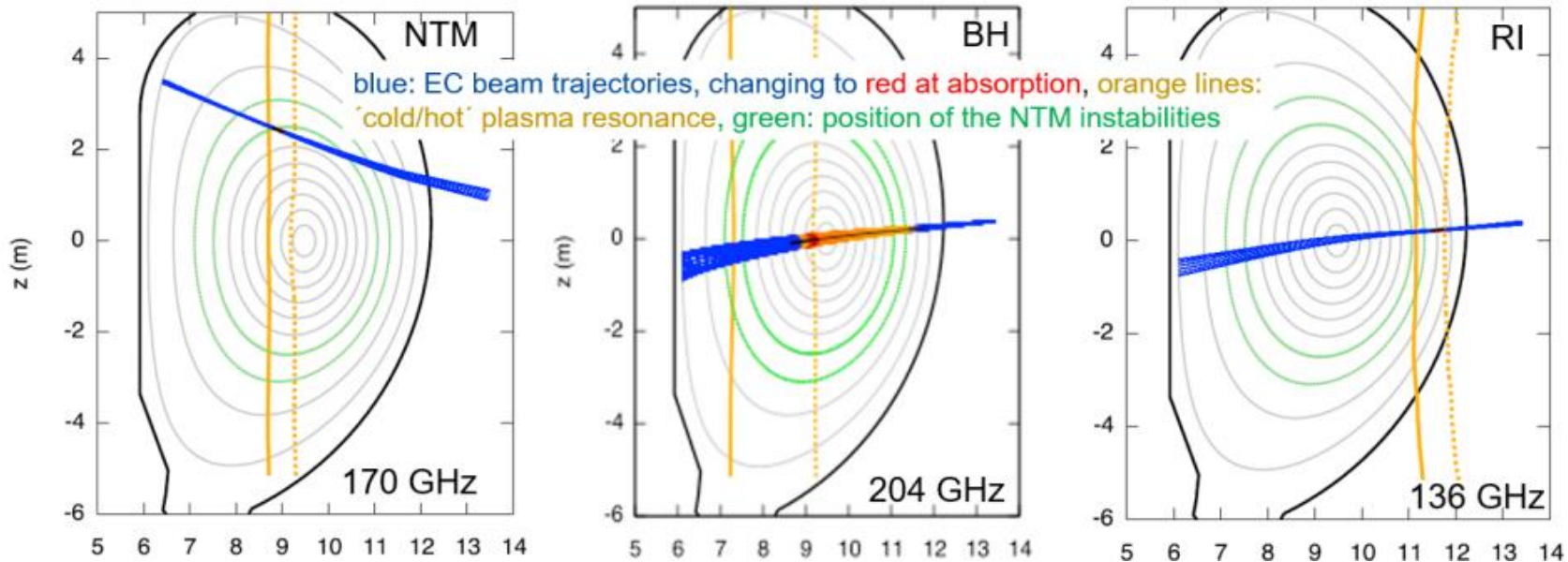

[Franke 21]

Outline

- The European DEMO and the role of Electron Cyclotron waves
- Theoretical background: resonance condition and ECCD efficiency
- ECCD for bulk current drive → how to optimize the ECCD efficiency
- ECCD for stabilization of neoclassical tearing modes → different requirements with respect to bulk current drive
- Recent developments (wave scattering, thermal instability, extraordinary-mode injection)

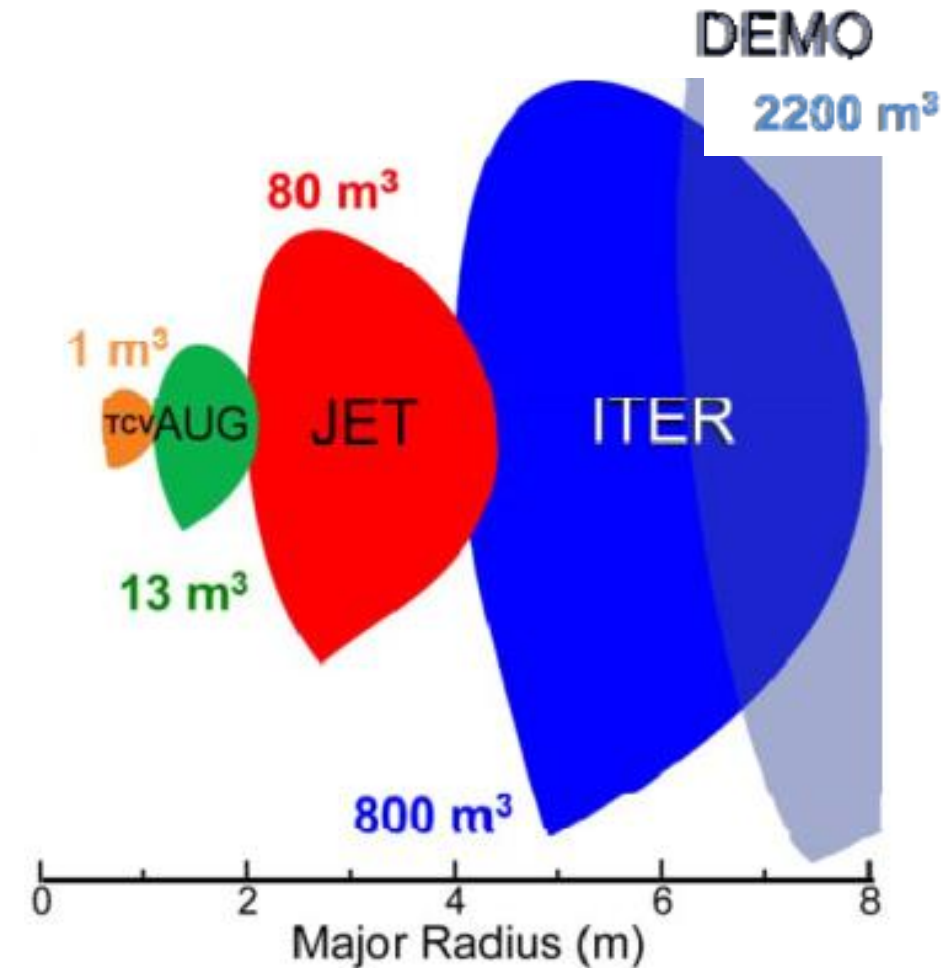

The theoretician's view: it is very simple...

- Example of EC wave simulation for the ASDEX Upgrade tokamak (remember $\Omega_e \sim B \sim 1/R$)

$\omega = 2\Omega_e$ (cold resonance, 2nd harmonic)

30285, t:3.45, gyrotron: 0, rz

Beam path

injection (nearly) perpendicular to magnetic field

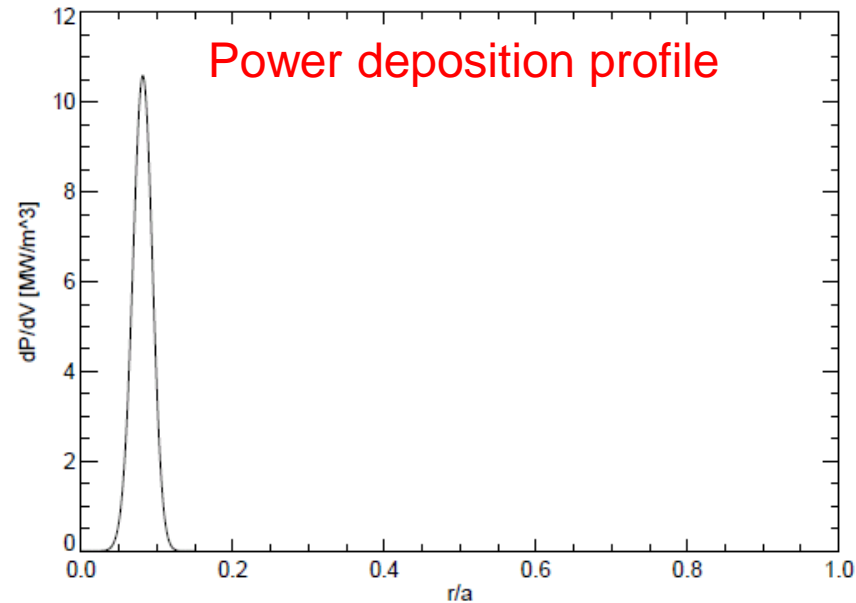
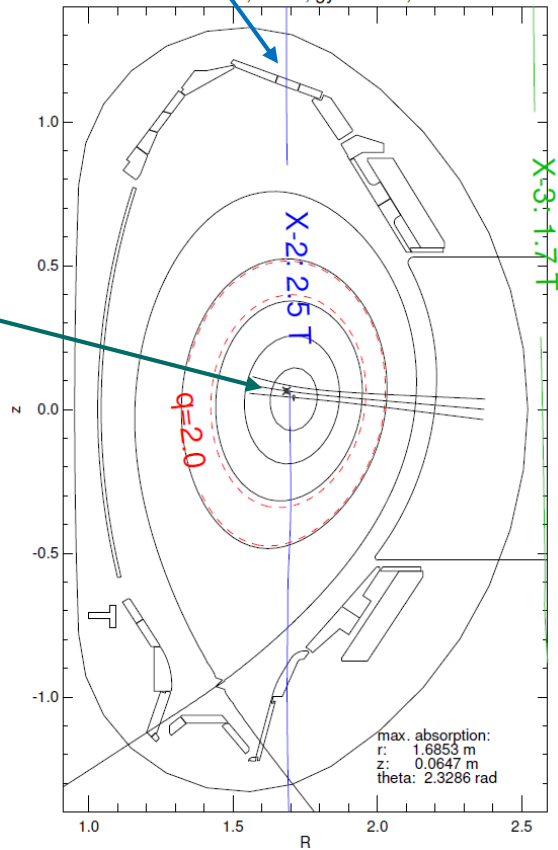

TORBEAM code
[Poli 01 & 18]

The theoretician's view: it is very simple...

- Example of EC wave simulation for the ASDEX Upgrade tokamak (remember $\Omega_e \sim B \sim 1/R$)

$\omega = 2\Omega_e$ (cold resonance, 2nd harmonic)

Beam path

injection (nearly perpendicular to magnetic field)

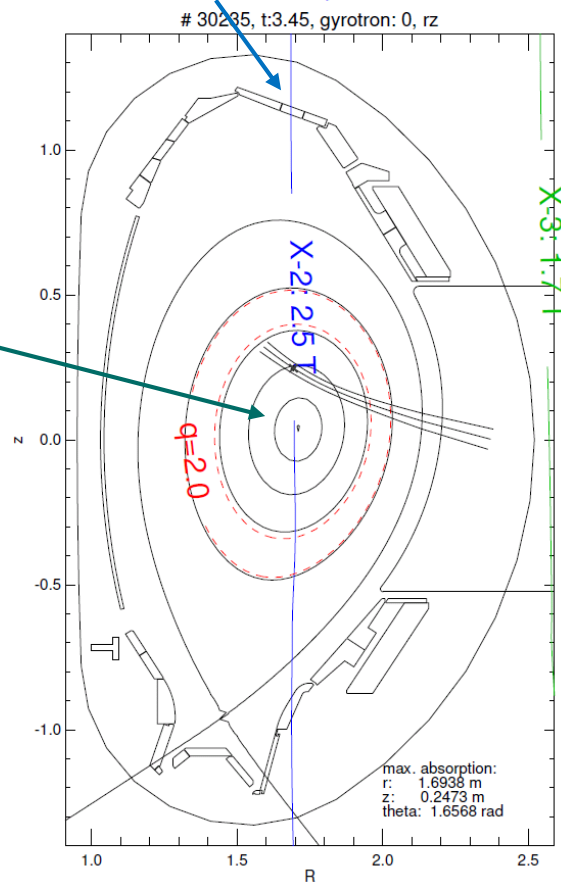

- For a given wave frequency, shift the deposition location by **steering the beam through the launch angles** (requires in general movable mirrors)

Power deposition profile

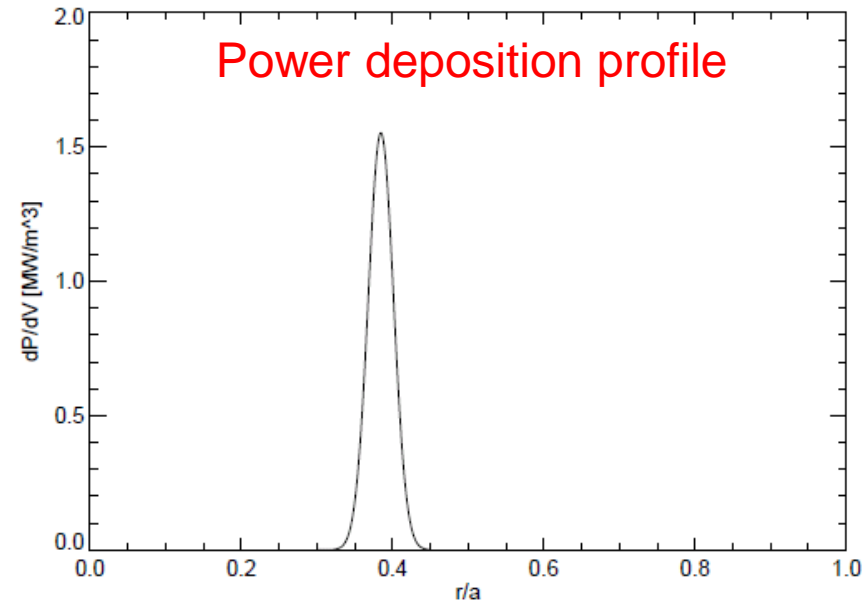

TORBEAM code
[Poli 01 & 18]



The relativistic resonance condition

- Fundamental role of **relativistic effects** (Lorentz factor $\gamma = \sqrt{1 + u_{\parallel}^2 + u_{\perp}^2}$) and **Doppler shift**

$$\omega - \frac{n\Omega_e}{\gamma} - k_{\parallel}v_{\parallel} = 0 \quad \rightarrow \quad \gamma - n\bar{\Omega} - N_{\parallel}u_{\parallel} = 0 \quad \text{with } \bar{\Omega} = \Omega_e/\omega \text{ and } u = \gamma v/c$$

- Resonance curves **in velocity space** are **ellipses** intersecting the u_{\parallel} axis at

$$u_{\parallel, \mp} = \frac{nN_{\parallel}\bar{\Omega} \mp \sqrt{n^2\bar{\Omega}^2 - (1 - N_{\parallel}^2)}}{1 - N_{\parallel}^2} \quad \Rightarrow \quad \text{resonance possible if } n\bar{\Omega} \geq \sqrt{1 - N_{\parallel}^2}$$

- $u_{\parallel-}$ moves towards the Maxwellian bulk as the beam propagates towards the HFS (increasing Ω/ω)

Resonance curves for $N_{\parallel}=0.7$
(oblique launch ← finite toroidal
injection angle)

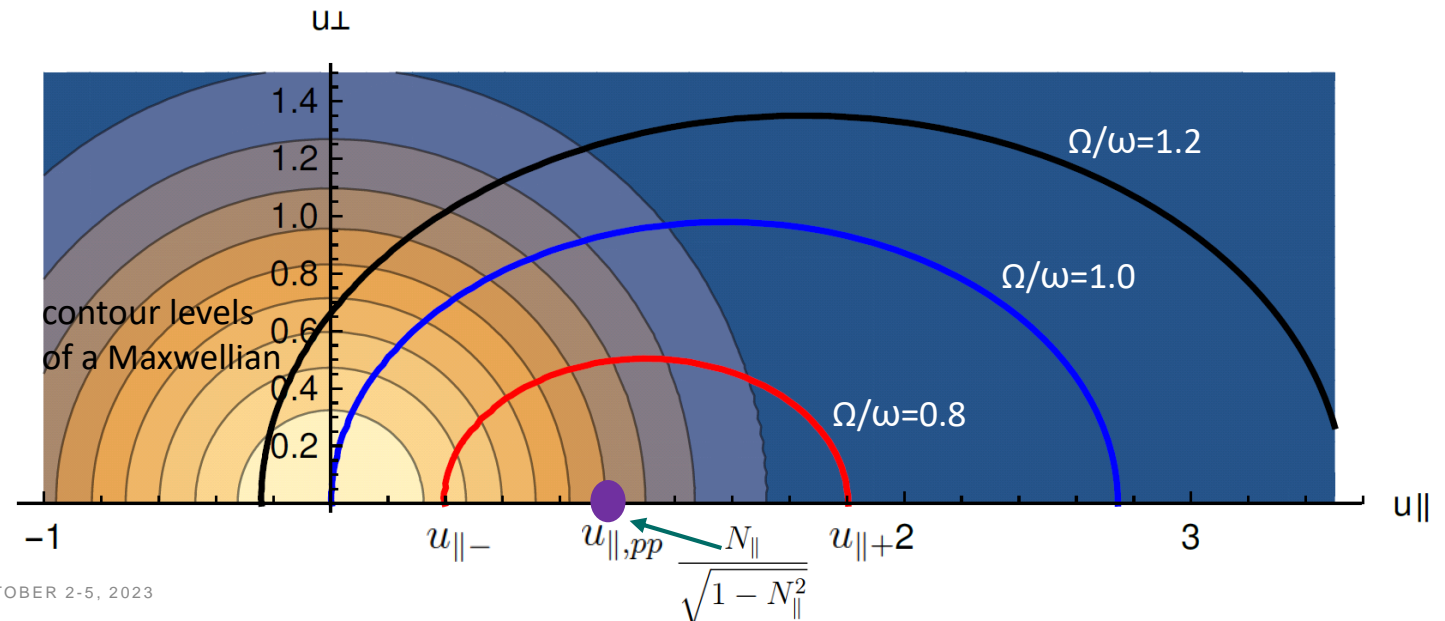



The relativistic resonance condition

- Fundamental role of **relativistic effects** (Lorentz factor $\gamma = \sqrt{1 + u_{\parallel}^2 + u_{\perp}^2}$) and **Doppler shift**

$$\omega - \frac{n\Omega_e}{\gamma} - k_{\parallel}v_{\parallel} = 0 \quad \rightarrow \quad \gamma - n\bar{\Omega} - N_{\parallel}u_{\parallel} = 0 \quad \text{with } \bar{\Omega} = \Omega_e/\omega \text{ and } u = \gamma v/c$$

- Resonance curves **in velocity space** are **ellipses** intersecting the u_{\parallel} axis at

$$u_{\parallel,\mp} = \frac{nN_{\parallel}\bar{\Omega} \mp \sqrt{n^2\bar{\Omega}^2 - (1 - N_{\parallel}^2)}}{1 - N_{\parallel}^2}$$

- Pinch point (first point in resonance) [Harvey 97]

$$u_{\parallel-} = u_{\parallel+} = \frac{N_{\parallel}}{\sqrt{1 - N_{\parallel}^2}} \equiv u_{\parallel,pp}$$

- Increasing N_{\parallel} **moves the absorption location** to the LFS and **shifts the resonance on more energetic** (less collisional) **electrons** \rightarrow higher current drive efficiency, weaker absorption

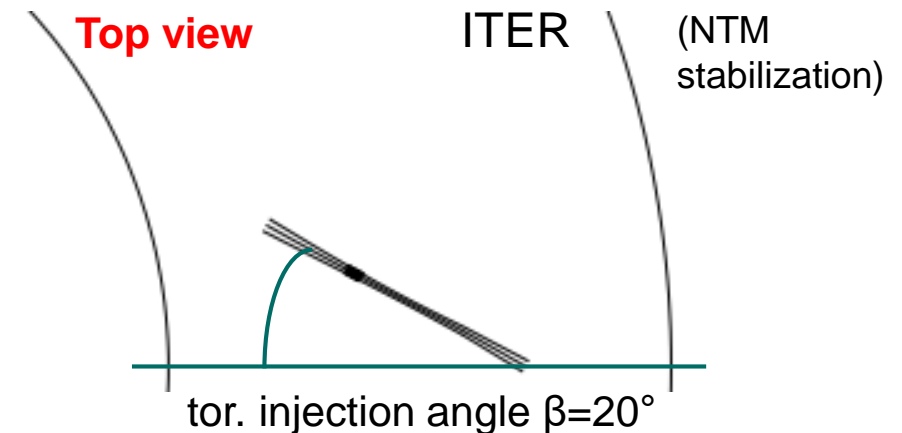



The relativistic resonance condition

- Fundamental role of **relativistic effects** (Lorentz factor $\gamma = \sqrt{1 + u_{\parallel}^2 + u_{\perp}^2}$) and **Doppler shift**

$$\omega - \frac{n\Omega_e}{\gamma} - k_{\parallel}v_{\parallel} = 0 \quad \rightarrow \quad \gamma - n\bar{\Omega} - N_{\parallel}u_{\parallel} = 0 \quad \text{with } \bar{\Omega} = \Omega_e/\omega \text{ and } u = \gamma v/c$$

- Resonance curves **in velocity space** are **ellipses** intersecting the u_{\parallel} axis at

$$u_{\parallel, \mp} = \frac{nN_{\parallel}\bar{\Omega} \mp \sqrt{n^2\bar{\Omega}^2 - (1 - N_{\parallel}^2)}}{1 - N_{\parallel}^2}$$

- Pinch point (first point in resonance) [Harvey 97]

$$u_{\parallel-} = u_{\parallel+} = \frac{N_{\parallel}}{\sqrt{1 - N_{\parallel}^2}} \equiv u_{\parallel, pp}$$

- Increasing N_{\parallel} **moves the absorption location** to the LFS and **shifts the resonance on more energetic** (less collisional) **electrons** \rightarrow higher current drive efficiency, weaker absorption

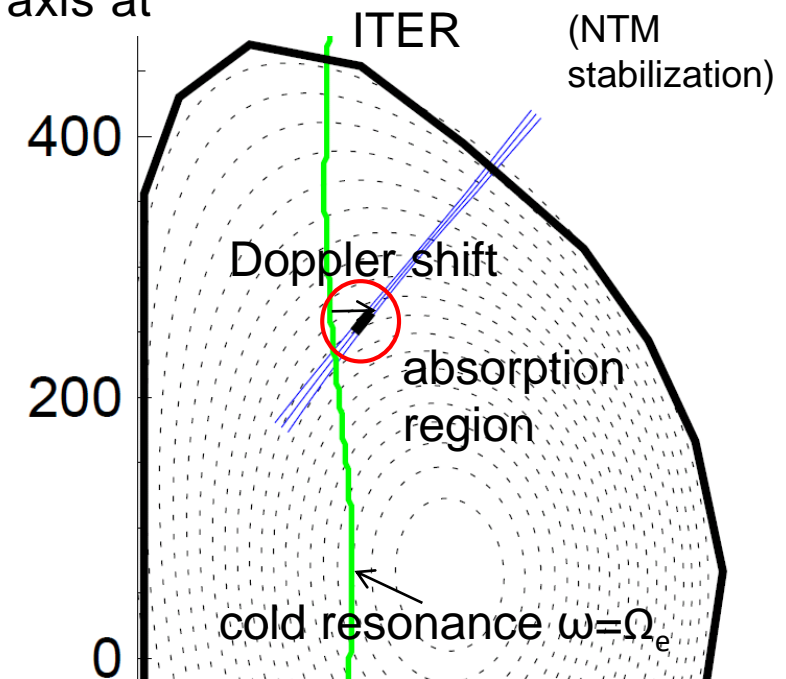



Fisch-Boozer mechanism and current drive efficiency

- Electron cyclotron waves **increase the perpendicular velocity** of the resonant electrons
- The **asymmetric** (with respect to $v_{||}$) **change in collisionality** leads to a current parallel to the magnetic field [Fisch & Boozer 80]

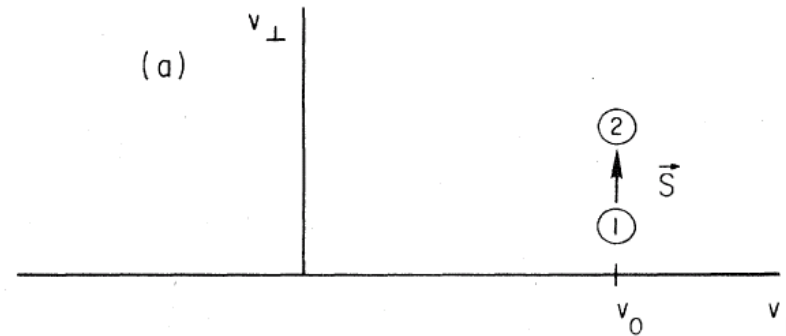

Electron cyclotron waves
increase v_{\perp} from ① to ②

[Fisch 87]



Fisch-Boozer mechanism and current drive efficiency

- Electron cyclotron waves **increase the perpendicular velocity** of the resonant electrons
- The **asymmetric** (with respect to v_{\parallel}) **change in collisionality** leads to a current parallel to the magnetic field [Fisch & Boozer 80]

- For **Coulomb collisions** in a plasma:
 $\nu \sim n_e/v^3$

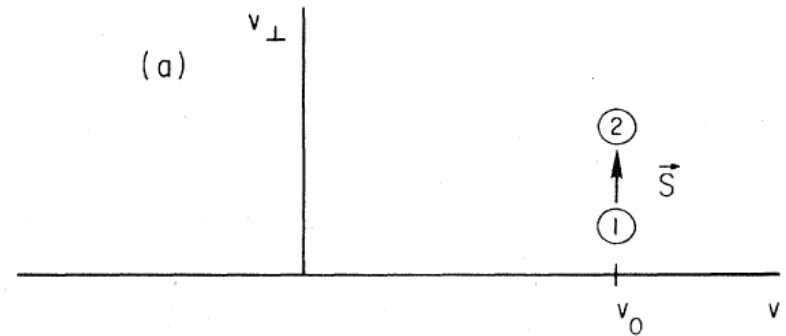

Electron cyclotron waves increase v_{\perp} from ① to ②

[Fisch 87]

Instantaneous current

$$J(t) = -en_{res} (v_{\parallel 2}e^{-\nu_2 t} - v_{\parallel 1}e^{-\nu_1 t})$$

average over $\Delta t \gg (1/\nu_1), (1/\nu_2)$

$$j = -en_{res} \frac{\Delta(v_{\parallel}/\nu)}{\Delta t}$$

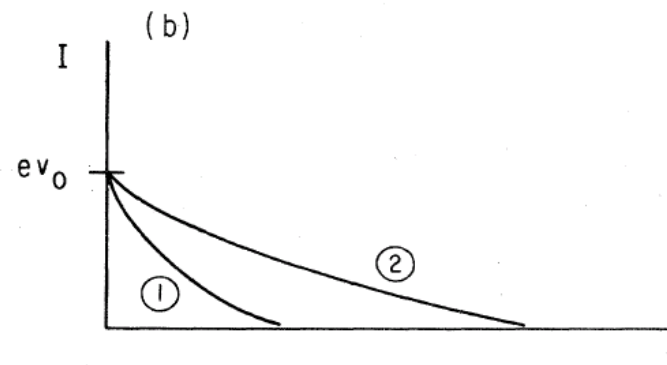

Parallel current form because of different momentum destruction rate for ① and ②

- The **current drive efficiency** $\eta=j/p$ scales roughly like $\eta \sim v^2/n_e \sim T_e/n_e$

Outline

- The European DEMO and the role of Electron Cyclotron waves
- Theoretical background: resonance condition and ECCD efficiency
- ECCD for bulk current drive → how to optimize the ECCD efficiency
- ECCD for stabilization of neoclassical tearing modes → different requirements with respect to bulk current drive
- Recent developments (wave scattering, thermal instability, extraordinary-mode injection)

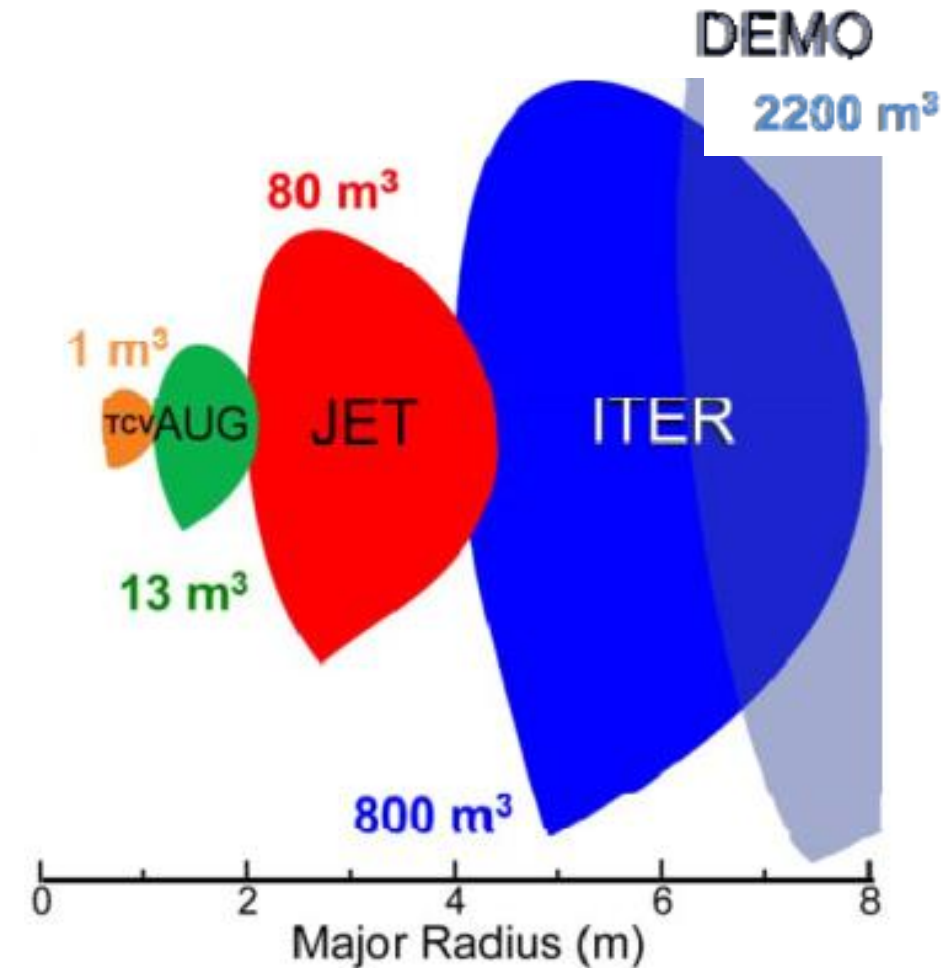

Optimizing the bulk current drive in DEMO

- Fundamental question: **How much current can be driven** by EC waves?
- Direct answer for a given scenario by **scanning the parameter space** (injection position, injection angles, wave frequency)
- First example [Poli 13]

DEMO model	B (T)	R (m)	R/a	I_p (MA)	n_{e0} (10^{19} m^{-3})	T_{e0} (keV)
Steady-state (peaked/flat n_e)	5.84	8.5	3	19.1/22.8	15.0/9.3	53/64
Pulsed (peaked/flat n_e)	7.45	9.6	4	14.4/17.3	16.8/10.4	57/54

Equatorial launch, pol. injection angle $\alpha = 0$

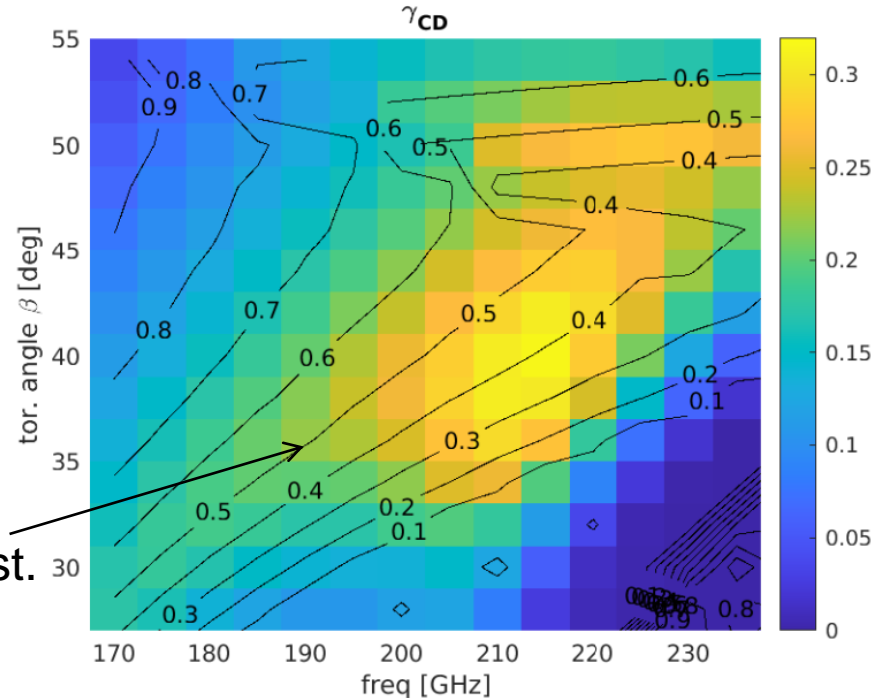

Top launch, freq = 230 GHz

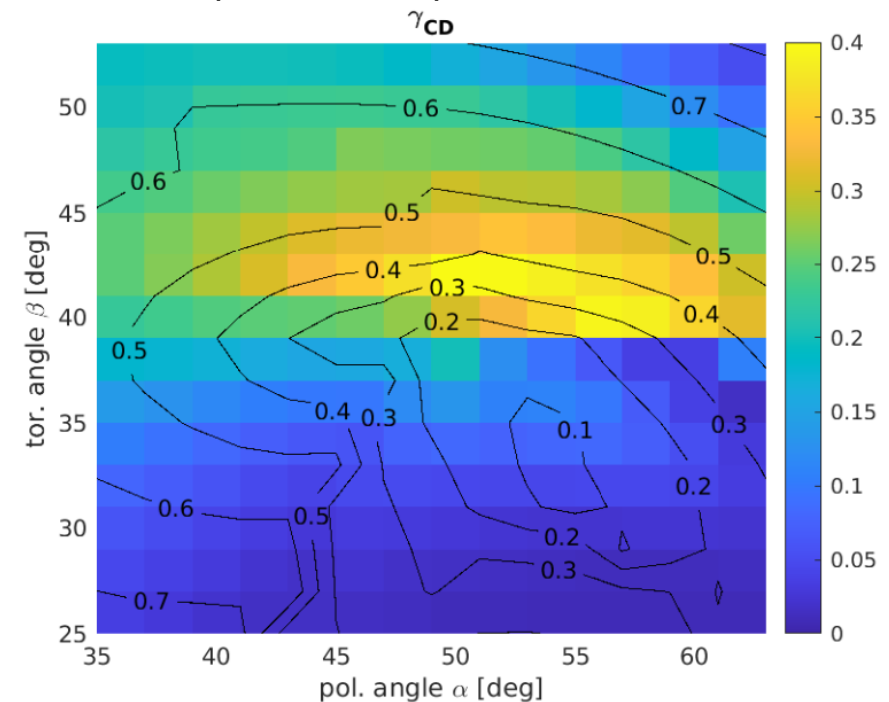

$$\gamma_{CD} = \frac{n_{20} R_m I_A}{P_W}$$

contours
 $\rho_{dep} = \text{const.}$

Optimizing the bulk current drive in DEMO

- Fundamental question: **How much current can be driven** by EC waves?
- Direct answer for a given scenario by **scanning the parameter space** (injection position, injection angles, wave frequency)
- First example [Poli 13]

DEMO model	B (T)	R (m)	R/a	I_p (MA)	n_{e0} (10^{19} m^{-3})	T_{e0} (keV)
Steady-state (peaked/flat n_e)	5.84	8.5	3	19.1/22.8	15.0/9.3	53/64
Pulsed (peaked/flat n_e)	7.45	9.6	4	14.4/17.3	16.8/10.4	57/54

Equatorial launch, pol. injection angle $\alpha = 0$

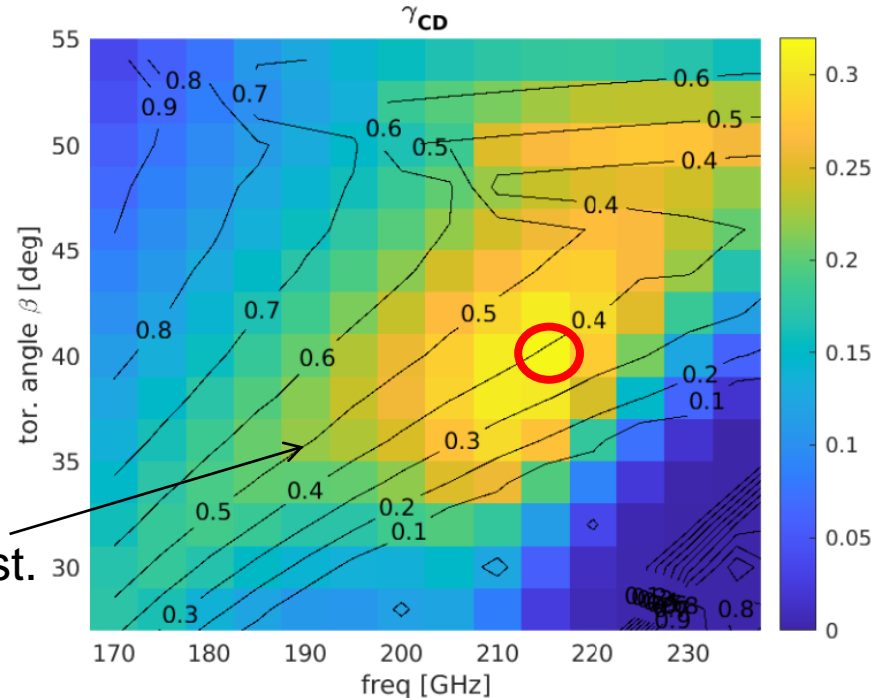

Top launch, freq = 230 GHz

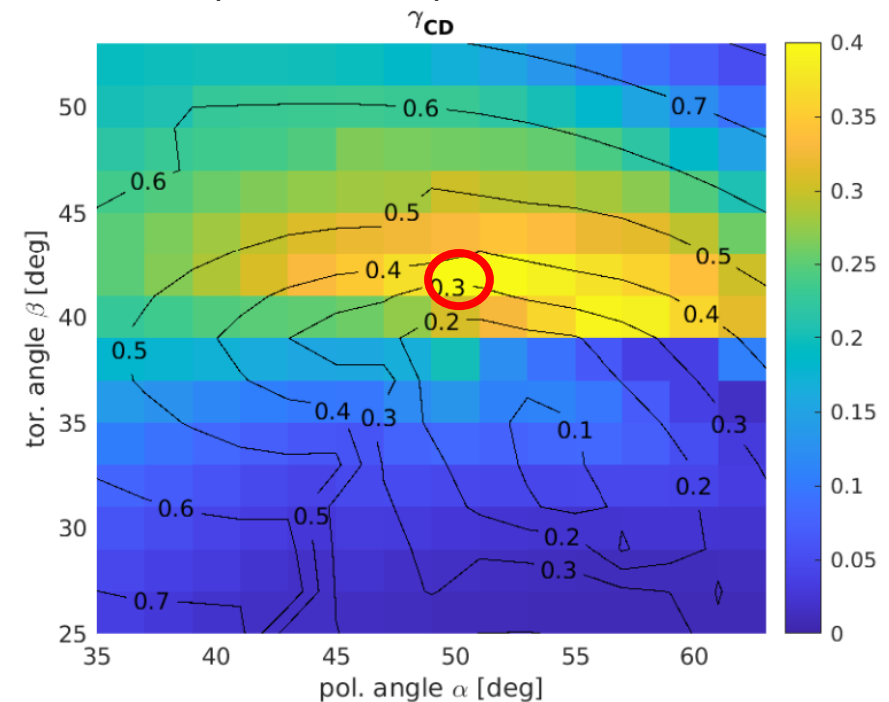

$$\gamma_{CD} = \frac{n_{20} R_m I_A}{P_W}$$

contours
 $\rho_{\text{dep}} = \text{const.}$



Optimizing the bulk current drive in DEMO

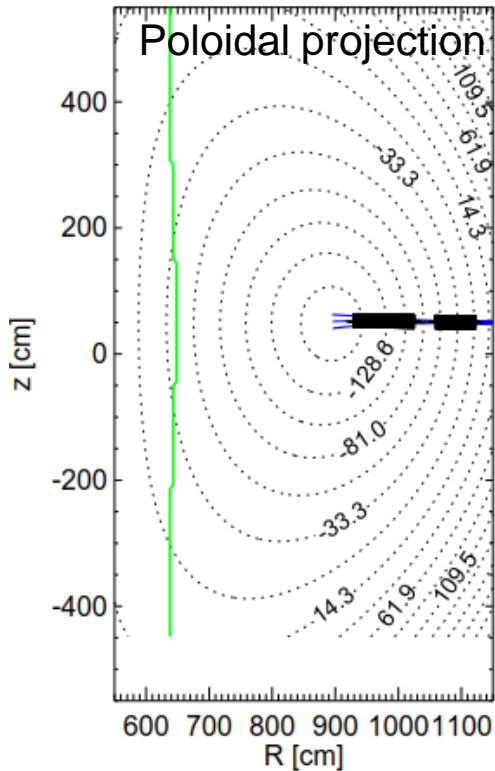

Equatorial launch

8% absorption before 1st harmonic

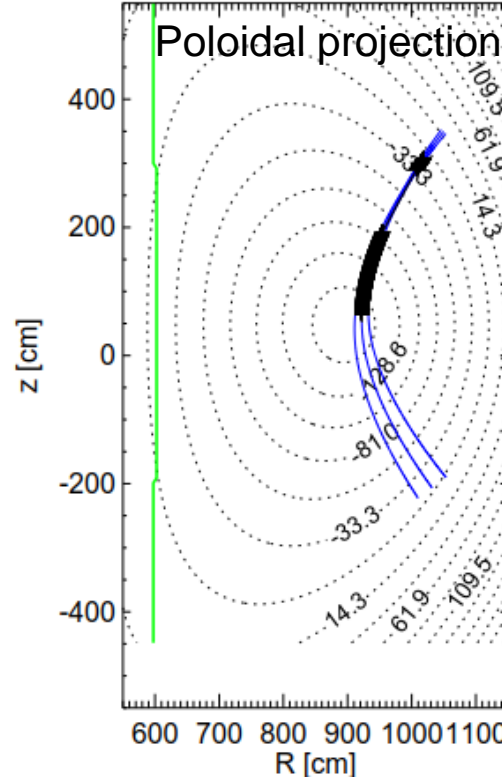
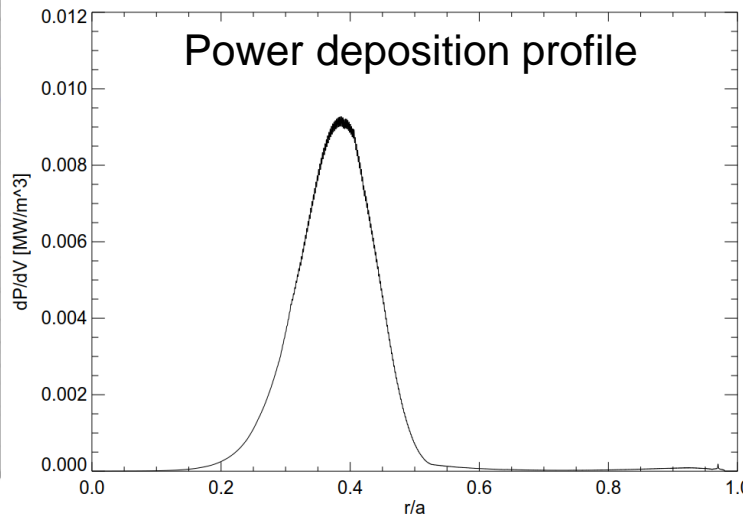

Top launch

7% absorption before 1st harmonic

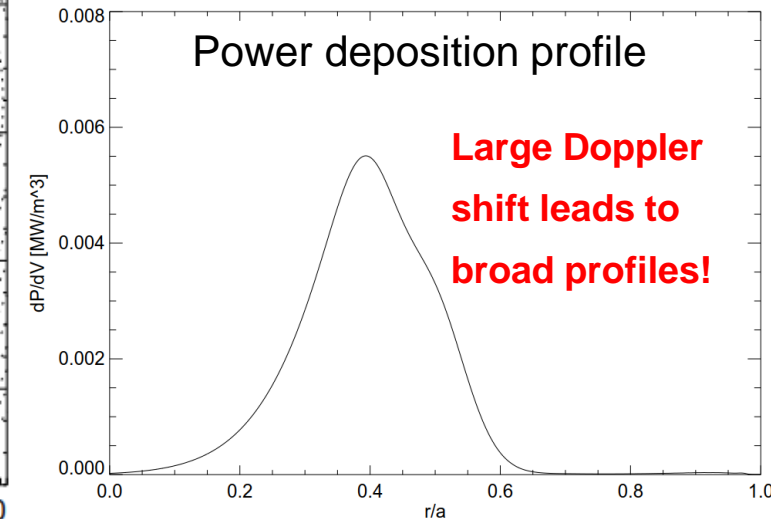

- High ECCD efficiency obtained for large $N_{||}$ → **high wave frequency** (ca. 1.4 x cold resonance frequency, typically > 200 GHz) **required** to compensate the Doppler shift and keep the absorption region near the plasma centre: **technology challenge**
- For **top launch**, the change in R (hence in Ω_e) along the beam path is slower than for equatorial launch → the resonance curve lingers on high-velocity electrons → **improved ECCD efficiency** [cf. Karney & Fisch 81]
- Increase in ECCD efficiency for top-launch scheme **recently demonstrated at DIII-D** [Chen 22]

Optimizing the bulk current drive in DEMO

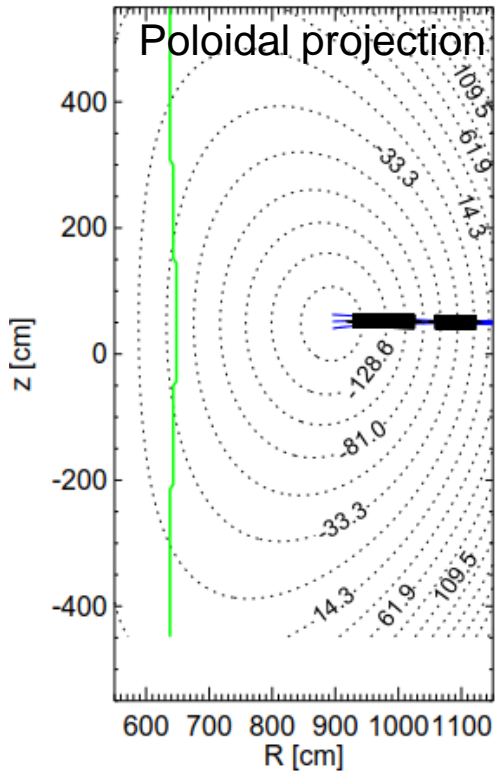

Equatorial launch

8% absorption before 1st harmonic

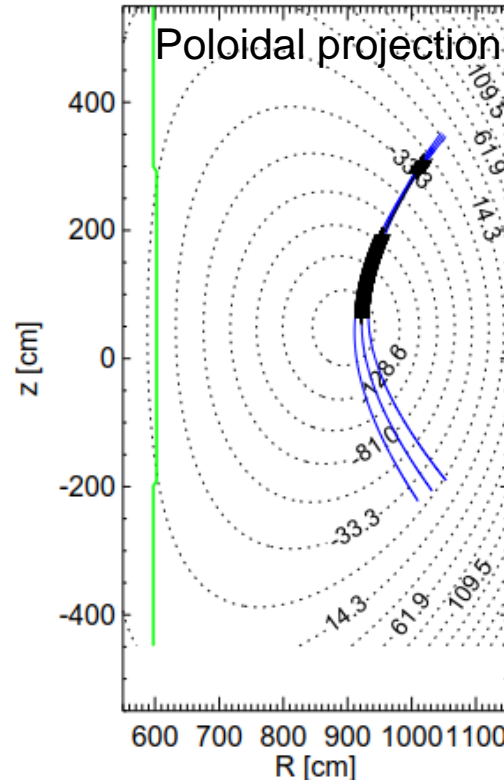
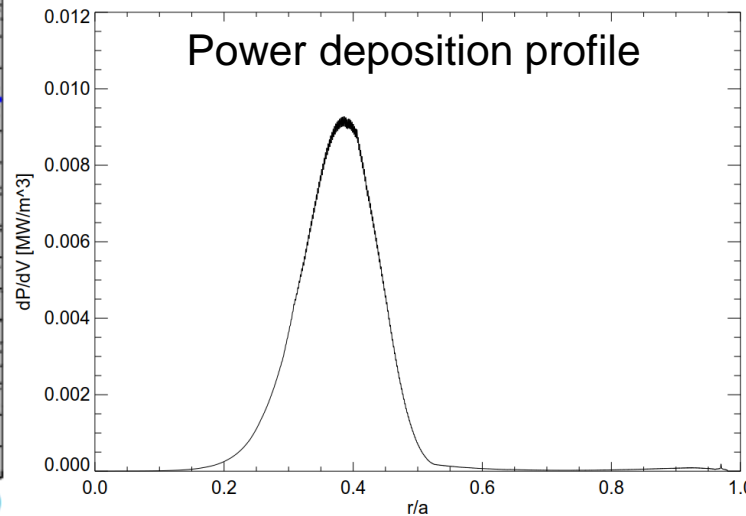

Top launch

7% absorption before 1st harmonic

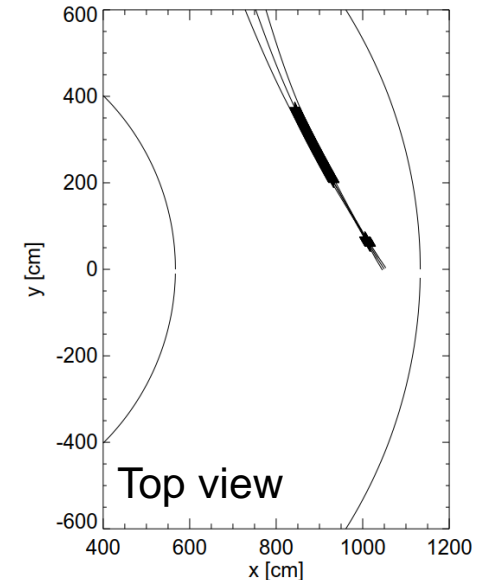

- High ECCD efficiency obtained for large $N_{||}$ → **high wave frequency** (ca. 1.4 x cold resonance frequency, typically > 200 GHz) **required** to compensate the Doppler shift and keep the absorption region near the plasma centre: **technology challenge**
- For **top launch**, the change in R (hence in Ω_e) along the beam path is slower than for equatorial launch → the resonance curve lingers on high-velocity electrons → **improved ECCD efficiency** [cf. Karney & Fisch 81]
- Increase in ECCD efficiency for top-launch scheme **recently demonstrated at DIII-D** [Chen 22]

ECCD efficiency saturation with increasing T_e

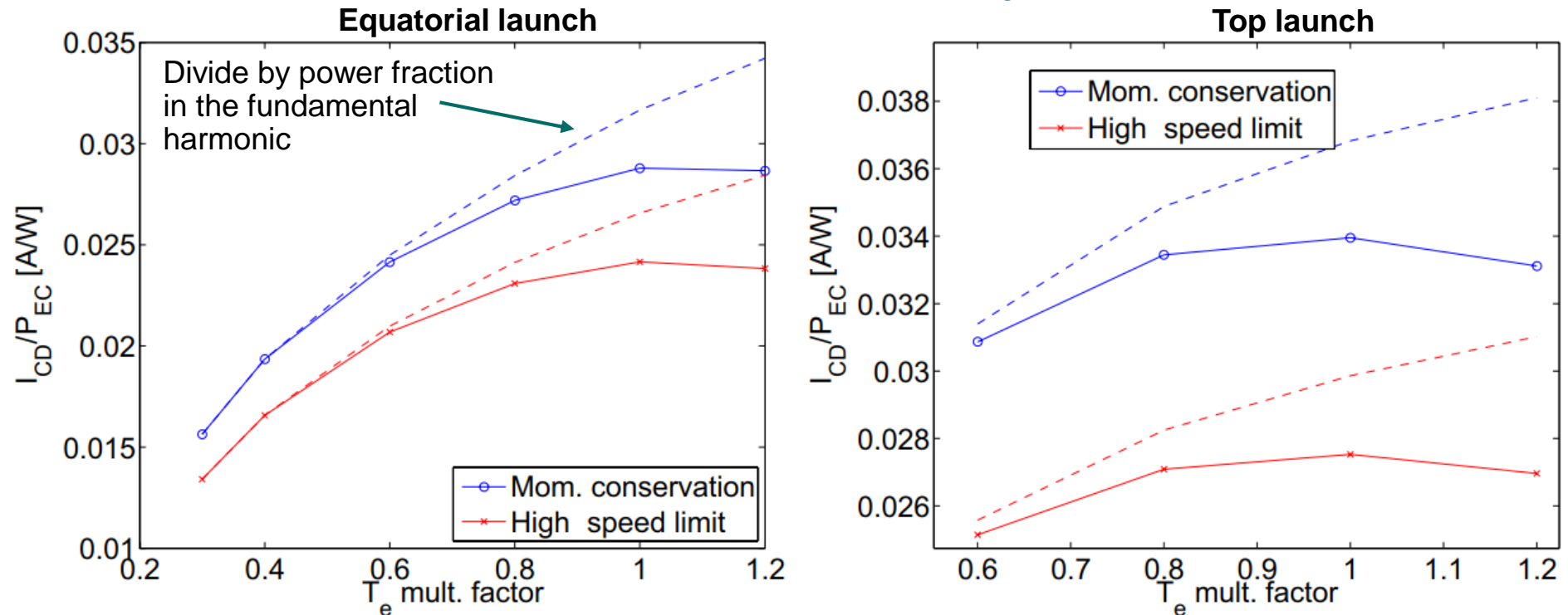

- The ECCD efficiency cannot be optimized by increasing the electron temperature indefinitely: absorption by next harmonic kicks in (parasitic absorption) → **ECCD efficiency saturation** at ca. $T_e = 30$ keV [cf. Harvey 97 for ITER]
- Parasitic absorption occurs both **before** the lower harmonic becomes accessible and **at the location** where it is accessible [harmonic overlap, Smith 87]
- Typical value of **achievable central ECCD in favourable scenarios: 50 kA/MW**



Can we predict the maximum ECCD from global parameters?

- In the optimization strategy shown before, the maximum achievable ECCD efficiency is determined by **scanning the parameter space** (several thousands of runs, each requiring ca 1 s)
- Pro's: accurate evaluation; Con's: **Too time consuming** for a repeated evaluation in a larger loop over tokamak parameters (optimization); **not possible** if equilibrium and profiles are not available (like in systems codes, 0D)



Can we predict the maximum ECCD from global parameters?

- In the optimization strategy shown before, the maximum achievable ECCD efficiency is determined by **scanning the parameter space** (several thousands of runs, each requiring ca 1 s)
- Pro's: accurate evaluation; Con's: **Too time consuming** for a repeated evaluation in a larger loop over tokamak parameters (optimization); **not possible** if equilibrium and profiles are not available (like in systems codes, 0D)
- Infer maximum ECCD current if only global parameters are known from **single numerical evaluation** of the ECCD efficiency at a **“representative point”**
- Fundamental idea: the **maximum ECCD is a trade-off** between two competing effects
 - Need for high-energy (low-collisionality) electrons → **favours resonance on the tail** of the distribution
 - Need for sufficiently high absorption → **favours resonance on the bulk**
- Strategy implemented in the module HARE coupled to the PROCESS systems code → typical runtime 0.1 ms [Poli 18]



HARE (Hare Analyses Reactor ECCD)

- Very good **agreement with full TORBEAM optimization**

	R_0 (cm)	a (cm)	B_0 (T)	n_{e0} (10^{19} m^{-3})	T_{e0} (keV)	Z_{eff}
ITER	620	201	5.3	10.56	24.49	1.76
DEMO1	907	292	5.66	10.50	33.25	2.0
DEMO2 nflat	749.9	288.5	5.627	9.94	31.17	4.18
DEMO2 npeak	749.9	288.5	5.627	17.99	23.50	4.13
flexi-DEMO	840	270	5.8	10.6	41.19	1.13

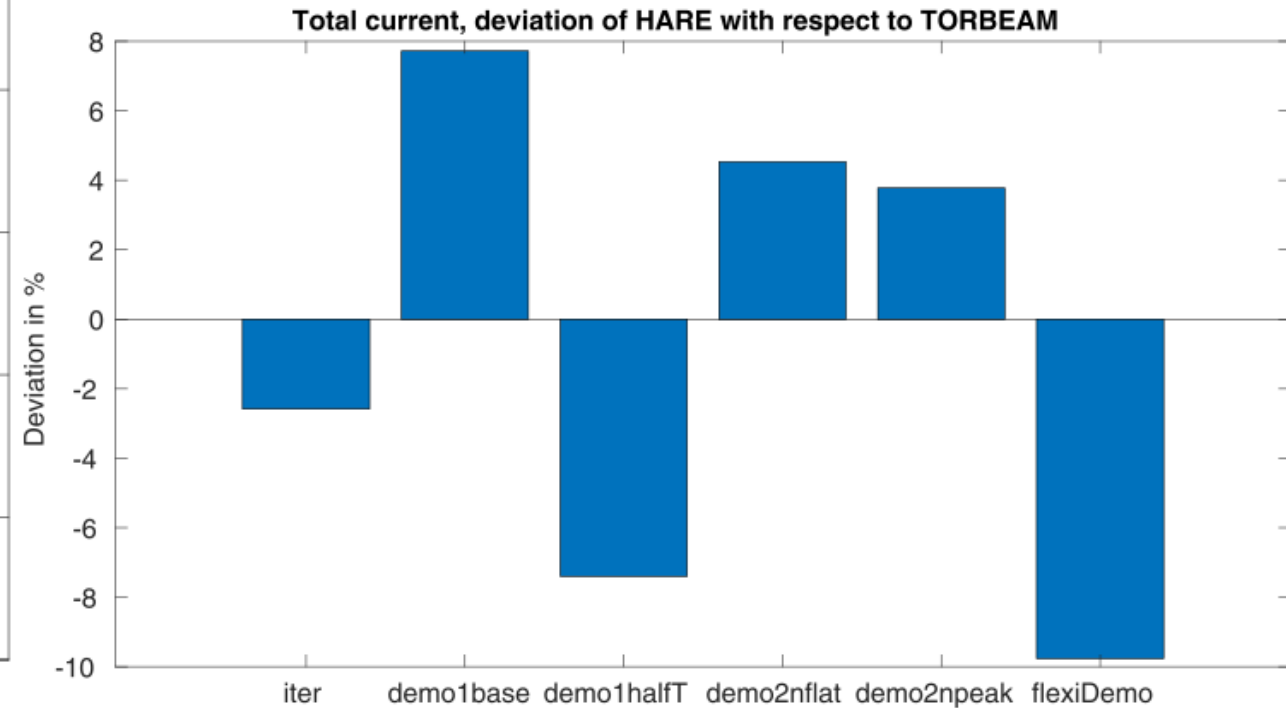
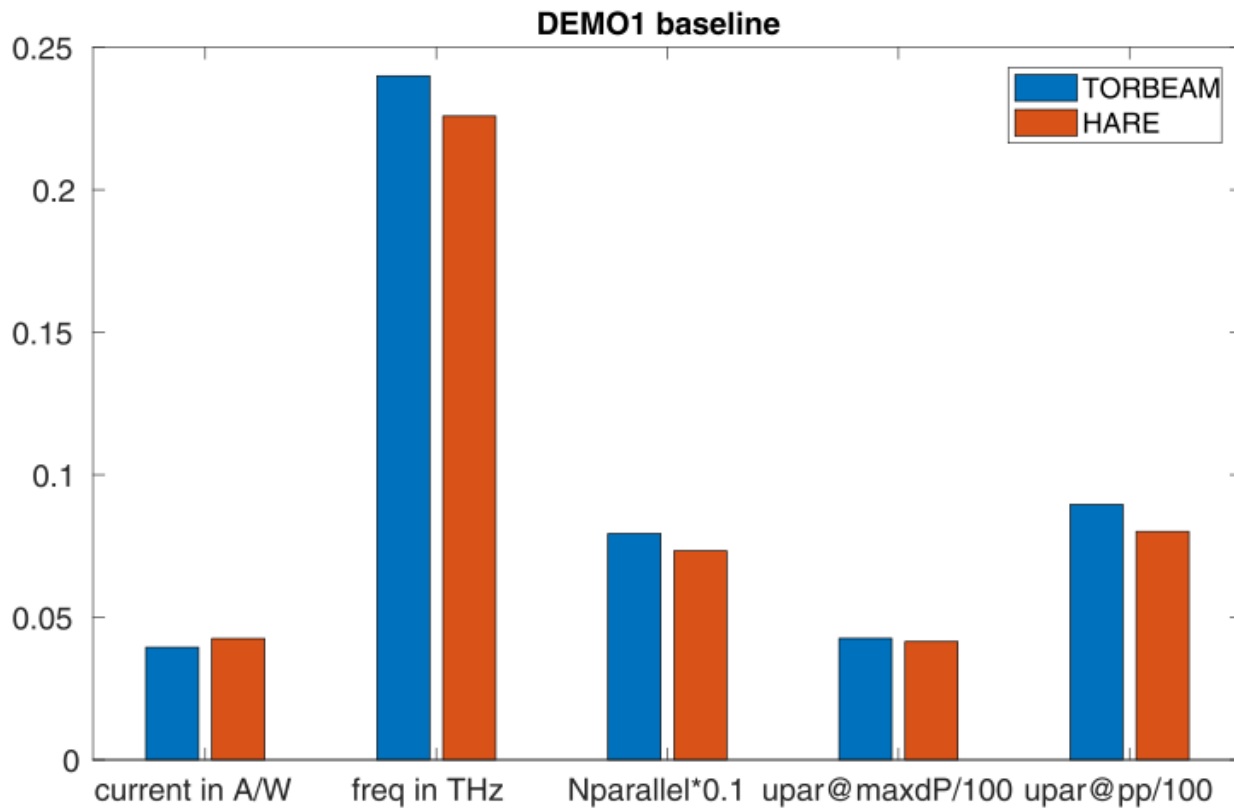



Can we replace the inductive current with ECCD?

- ASTRA steady-state scenario: $B=5.8$ T, $R=8.4$ m, $a=2.88$ m, $Z_{\text{eff}}=1.48$, strong off-axis CD with 50 kA/MW

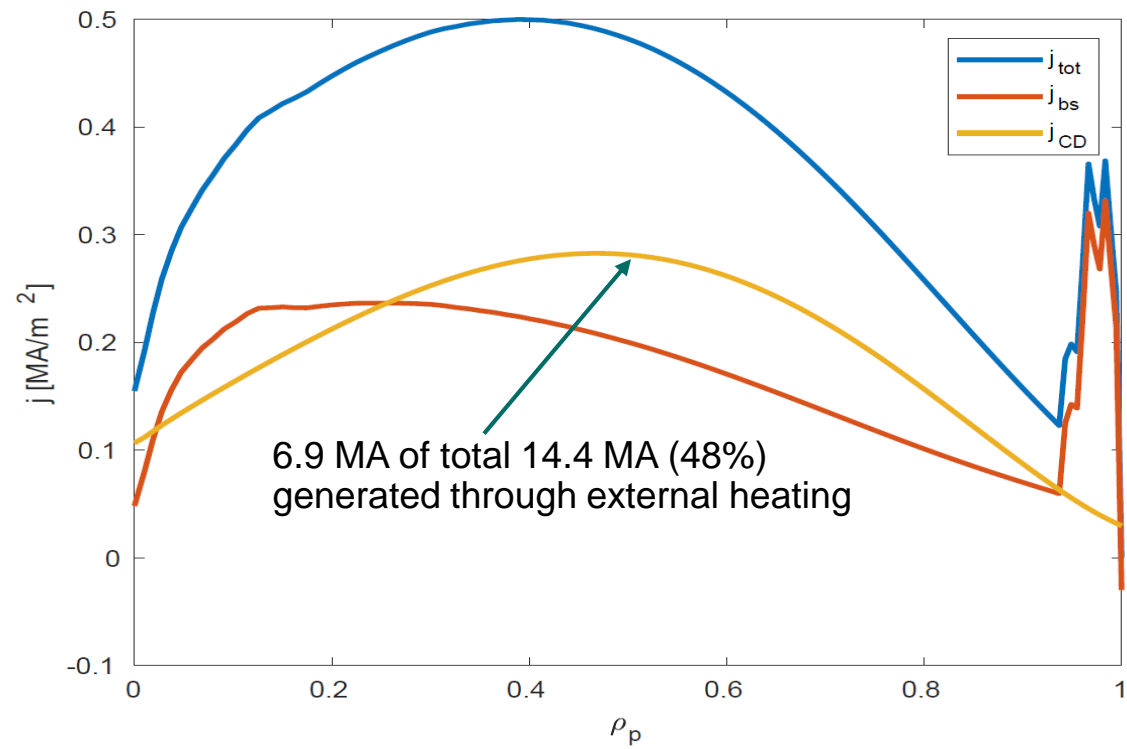
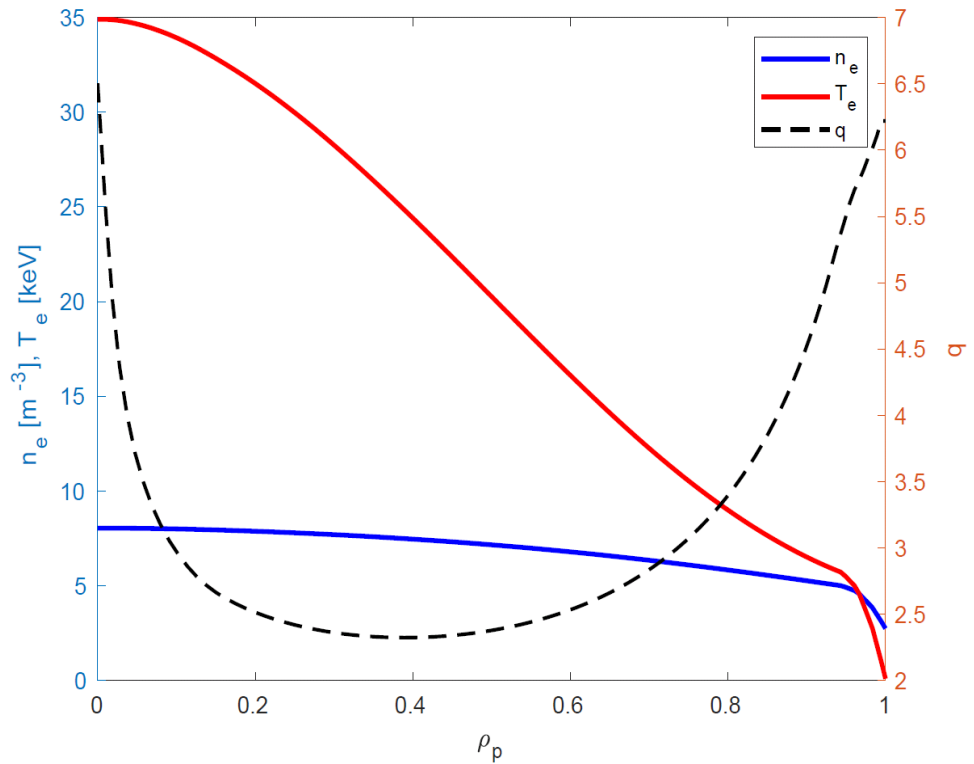

Can we replace the inductive current with ECCD?

- ASTRA steady-state scenario: $B=5.8$ T, $R=8.4$ m, $a=2.88$ m, $Z_{\text{eff}}=1.48$, strong off-axis CD with 50 kA/MW
- High central ECCD deteriorates with radius due to trapped particles and **unfavourable T_e/n_e**
- Replacing the inductive current with ECCD becomes **inefficient in the outer part** of the plasma column
- NBCD increases with trapped particle fraction and Z_{eff} [cf. Wagner 10 on ITER]

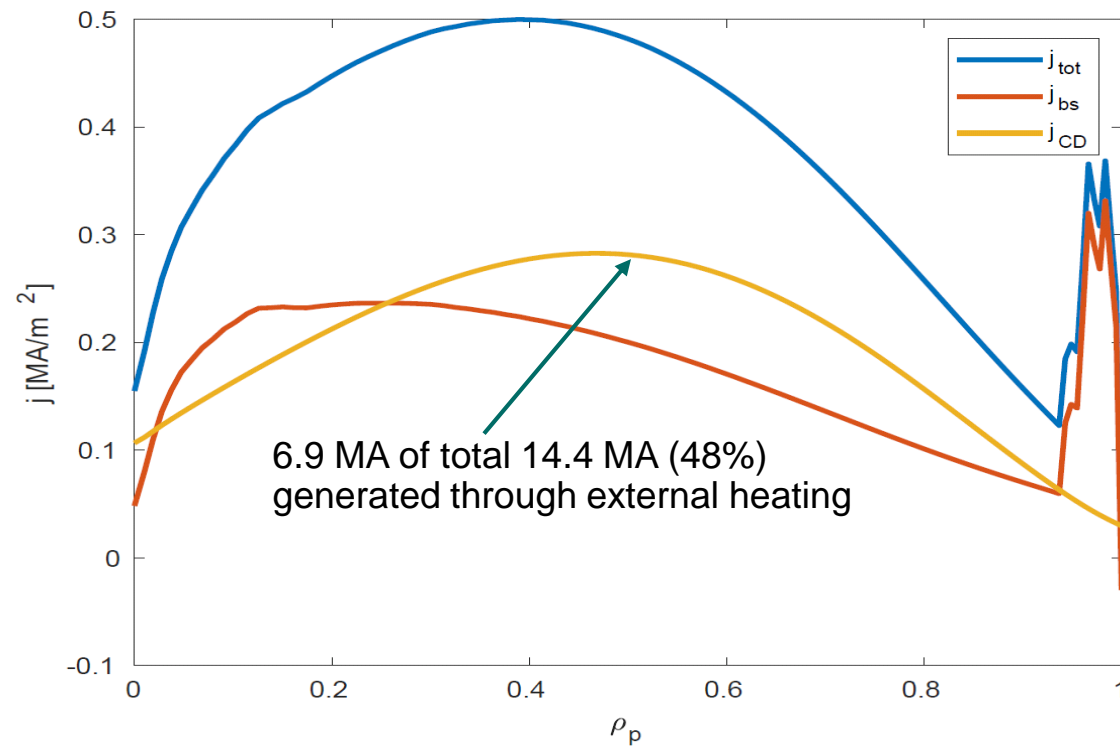
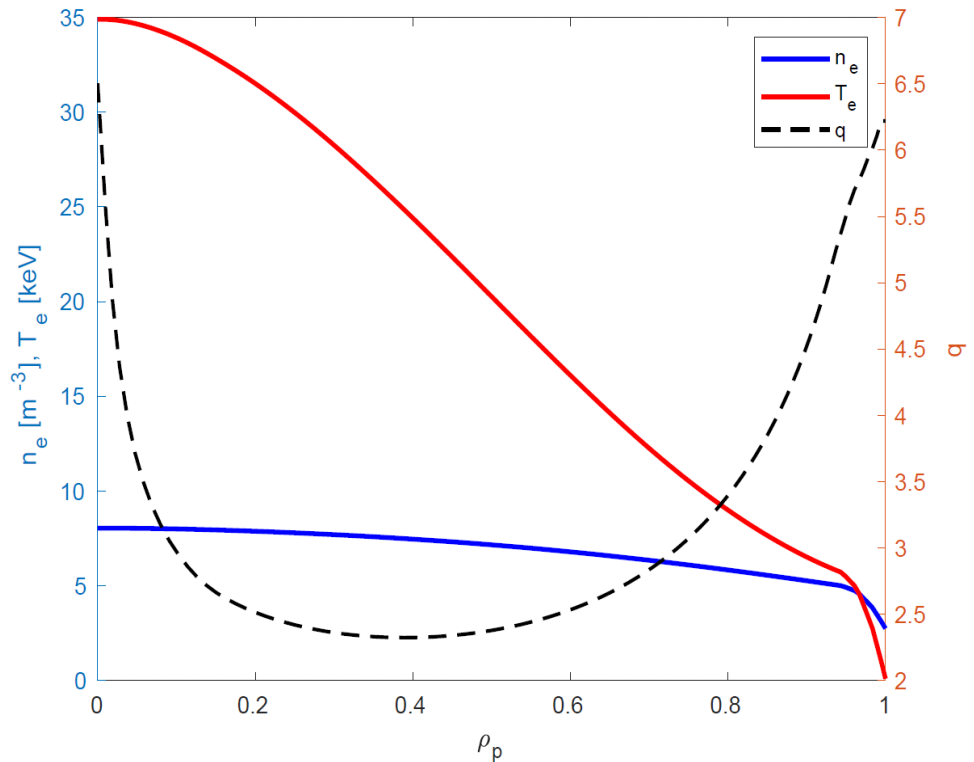

Can we replace the inductive current with ECCD?

- ASTRA steady-state scenario: $B=5.8$ T, $R=8.4$ m, $a=2.88$ m, $Z_{\text{eff}}=1.48$, strong off-axis CD with 50 kA/MW
- High central ECCD deteriorates with radius due to trapped particles and **unfavourable T_e/n_e**
- Replacing the inductive current with ECCD becomes **inefficient in the outer part** of the plasma column
- NBCD increases with trapped particle fraction and Z_{eff} [cf. Wagner 10 on ITER]
- **Required heating power (> 170 MW) too high** ☹️

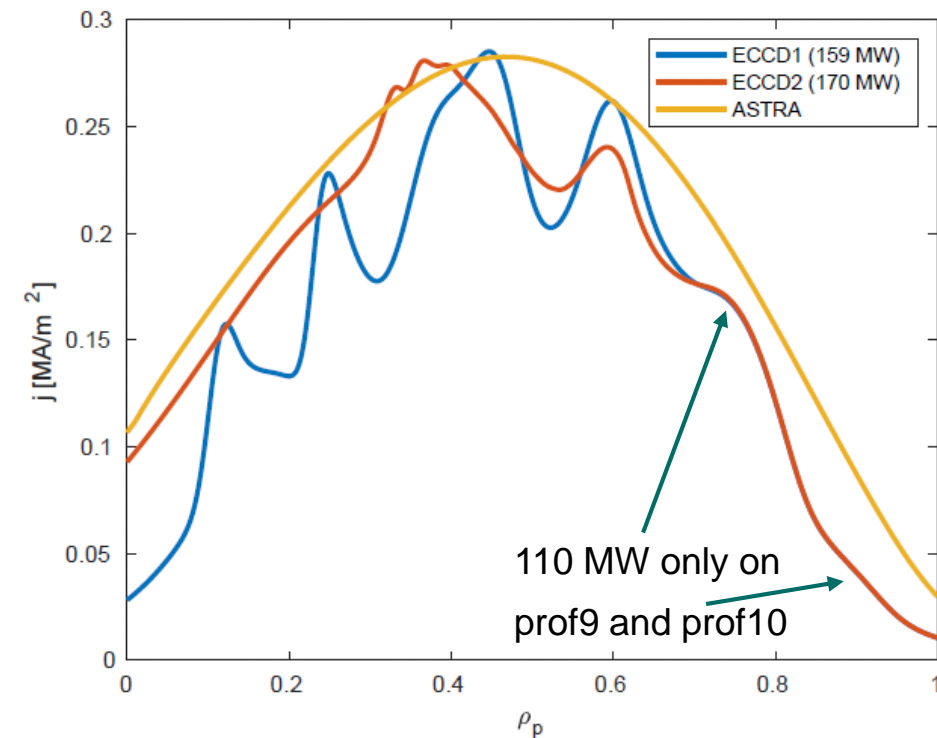
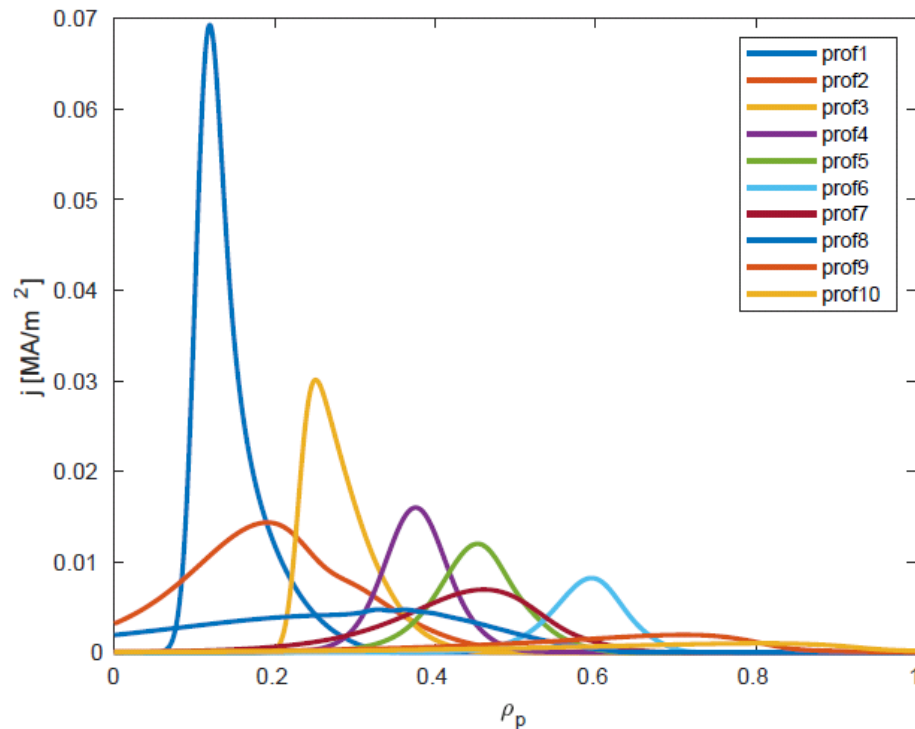

Outline

- The European DEMO and the role of Electron Cyclotron waves
- Theoretical background: resonance condition and ECCD efficiency
- ECCD for bulk current drive → how to optimize the ECCD efficiency
- ECCD for stabilization of neoclassical tearing modes → different requirements with respect to bulk current drive
- Recent developments (wave scattering, thermal instability, extraordinary-mode injection)

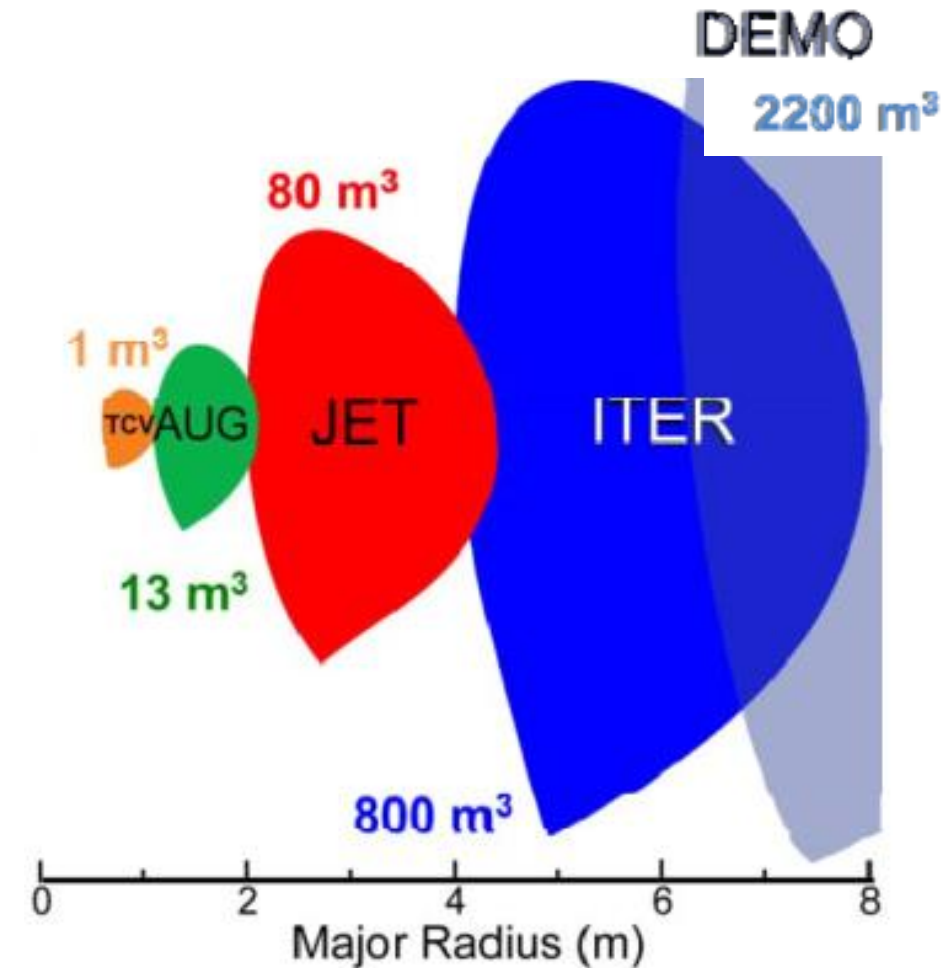

Stabilization of Neoclassical Tearing Modes

- The Neoclassical Tearing Mode (NTM) is a reconnecting magnetic perturbation **driven unstable by the bootstrap current perturbation** due to pressure flattening
- NTM evolution described by the **generalized Rutherford equation**
$$\frac{dW}{dt} \propto \Delta' + \Delta'_{bs} + \Delta'_{ECCD} + \dots$$
- ECCD can be used to locally replace the missing bootstrap current
- Criteria employed to assess the stabilization efficiency of the ITER EC system:
 - $j_{CD}/j_{bs} > 1.2$ (“large” W_{CD} , assumes ECCD modulation) [Zohm 07]
 - $W_{CD} j_{CD}/j_{bs} > 5$ cm (“small” $W_{CD} < 5$ cm) [Sauter 10]
- The analysis leads to an “optimum” EC profile width $W_{CD} = 5/1.2 = 4.2$ cm for ITER and ca. 6 cm for DEMO

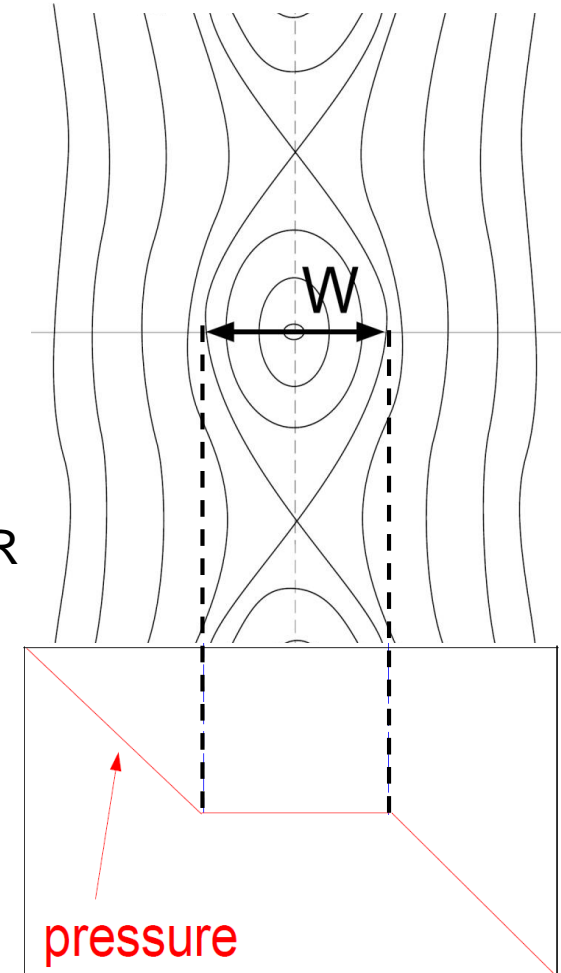



Stabilization of Neoclassical Tearing Modes

- Reminder: the **maximization of the total ECCD current leads to broad profiles** (in general beyond optimum width for NTM stabilization)
- **Lower $N_{||}$** and **lower frequency** expected for optimum NTM control with respect to maximum ECCD case

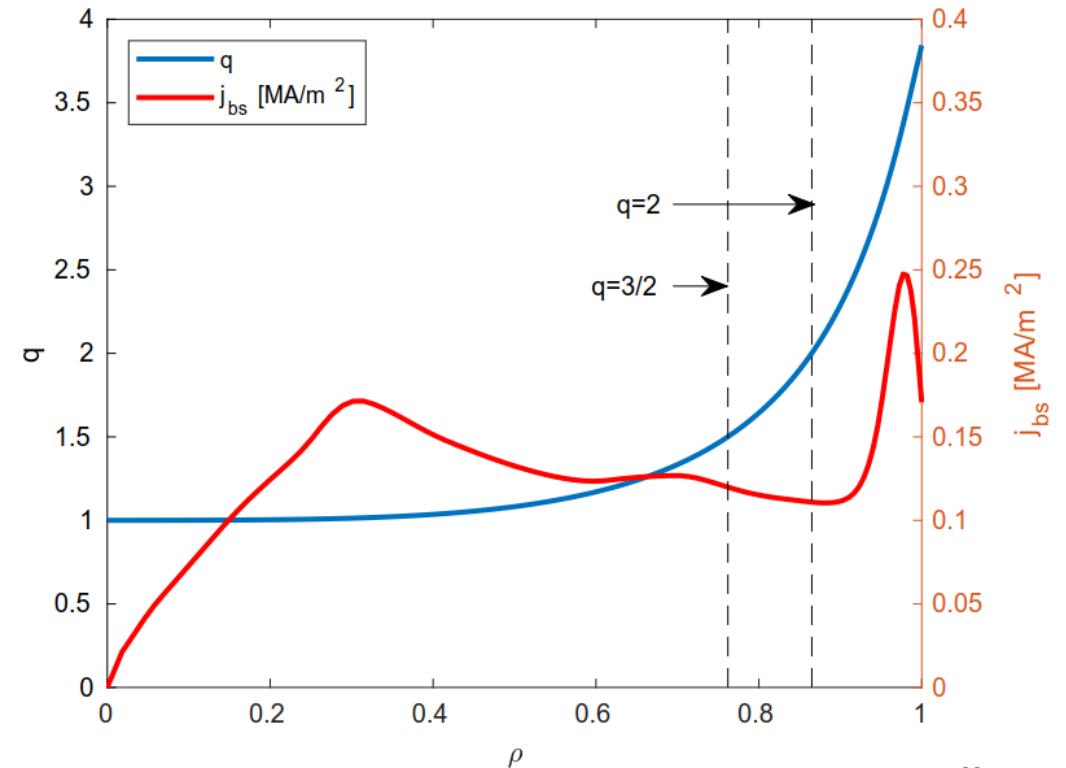
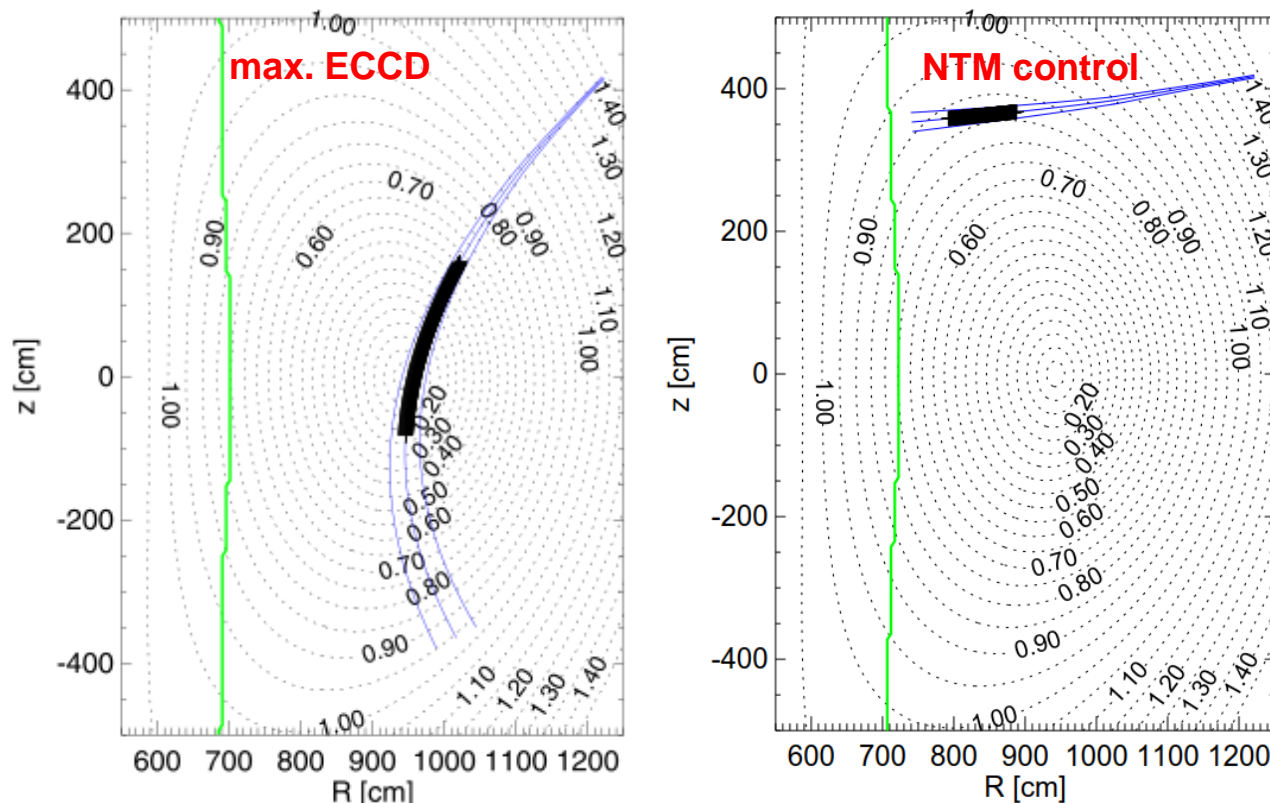



Stabilization of Neoclassical Tearing Modes

- Reminder: the **maximization of the total ECCD current leads to broad profiles** (in general beyond optimum width for NTM stabilization)
- **Lower $N_{||}$** and **lower frequency** expected for optimum NTM control with respect to maximum ECCD case

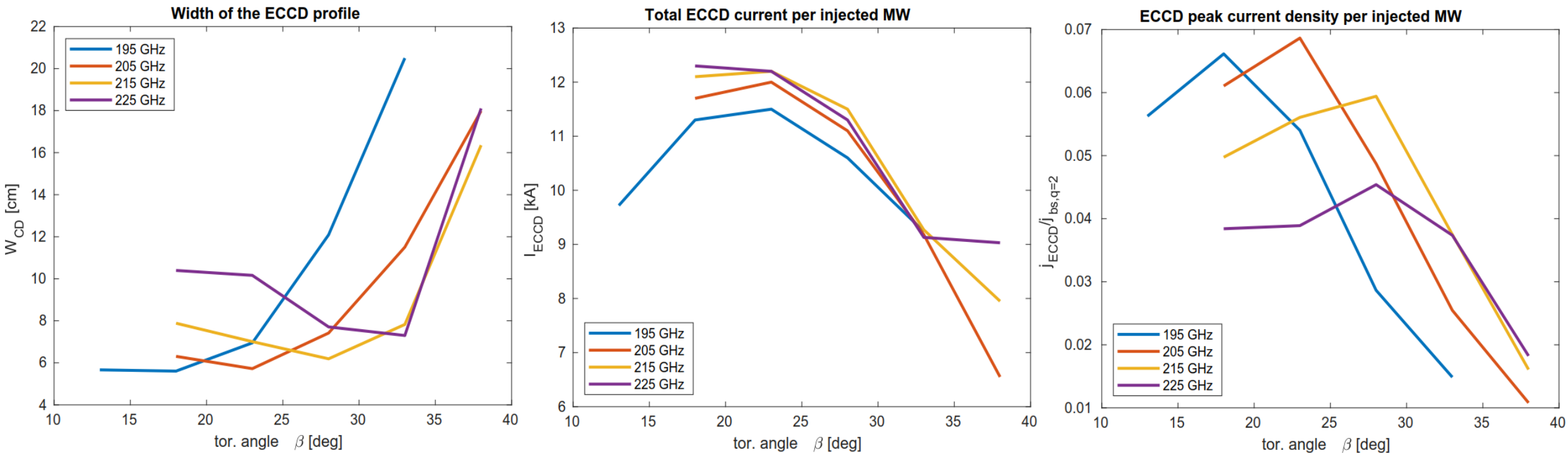

- For a frequency of 205 GHz, ca. **15 MW EC power required** to satisfy stabilization criterion

Alternative to beam steering

- **Present DEMO reference design** allows **focused beams** and **steerable mirrors** (steering system below the breeding blanket, replacement of part of the launcher possible / expected)
- Alternative concept: **Frequency-tuneable gyrotrons** to modify deposition location [Wu 21]

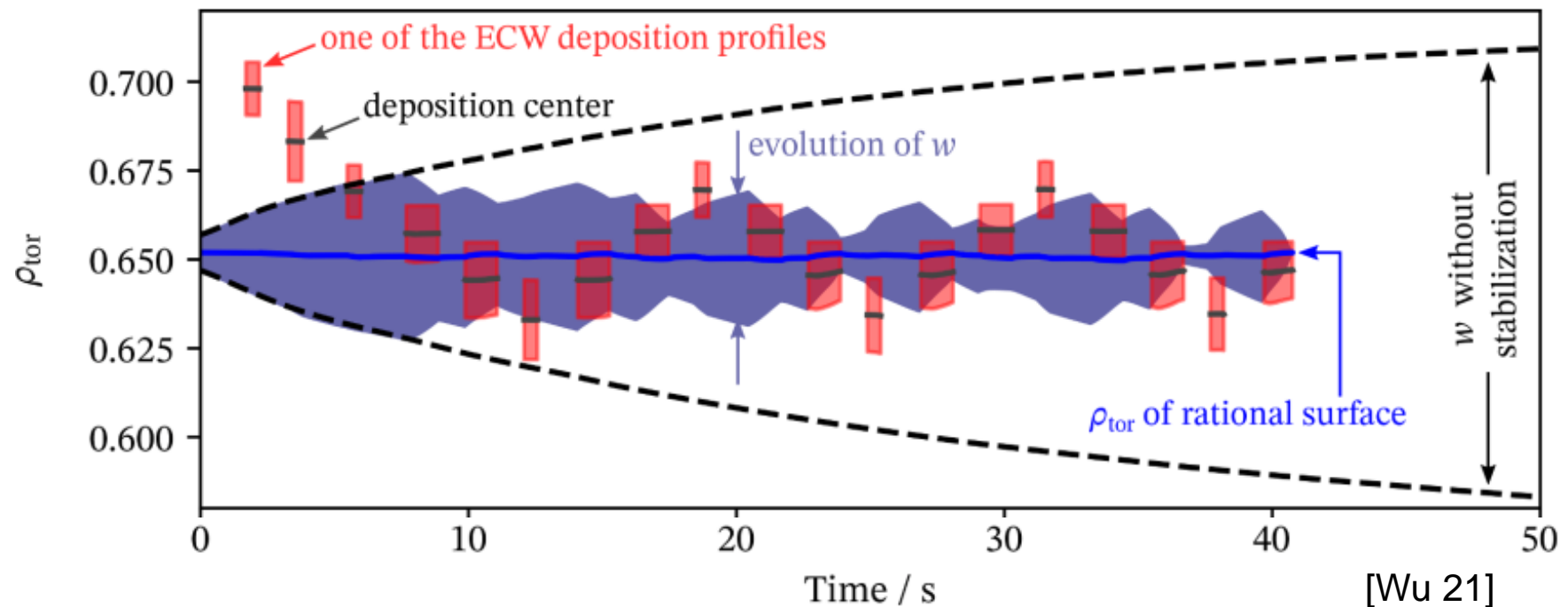
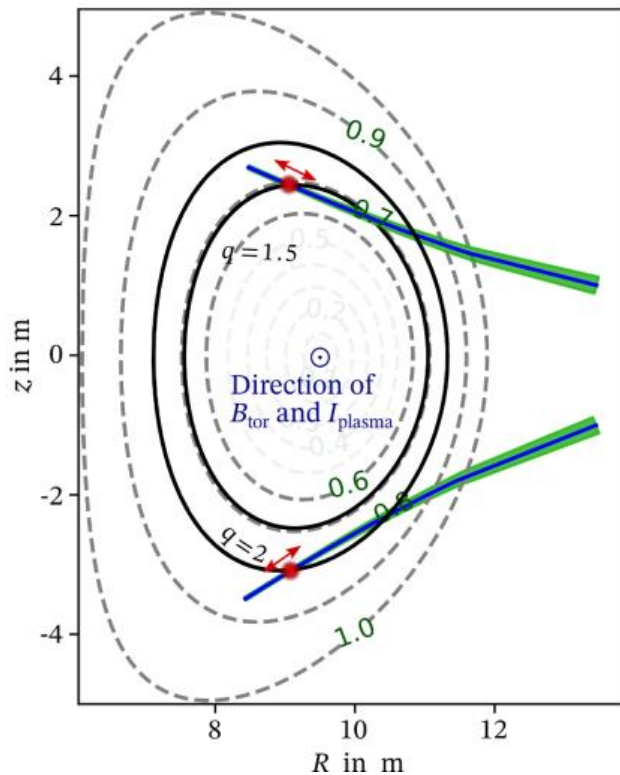

- **Sweeping strategy** requires **sufficient tuning speed** (here 0.96 GHz/s with a bandwidth of 9.6 GHz; 19 MW injected)

Outline

- The European DEMO and the role of Electron Cyclotron waves
- Theoretical background: resonance condition and ECCD efficiency
- ECCD for bulk current drive → how to optimize the ECCD efficiency
- ECCD for stabilization of neoclassical tearing modes → different requirements with respect to bulk current drive
- Recent developments (wave scattering, thermal instability, extraordinary-mode injection)

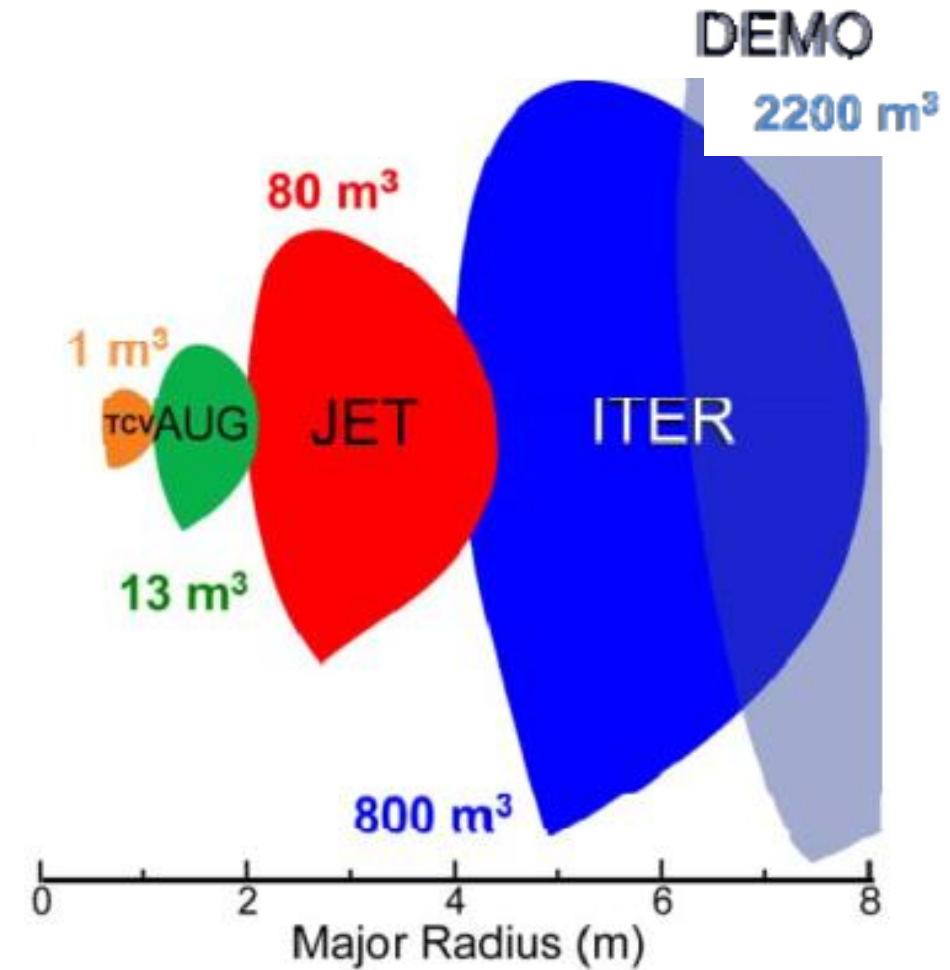

Beam broadening due to density fluctuations

- **Density fluctuations** act as random variations of the refractive index → radiation scattering and **beam broadening**
- Quantitative predictions through numerical solution of the wave kinetic equation: WKBeam code [Weber 15] ← statistically **averaged effect of fluctuations**

$$\begin{cases} Hw = 0 \\ \{H, w\} = -2\gamma w + \mathcal{S} \end{cases}$$

Propagation **Absorption** **Scattering operator**

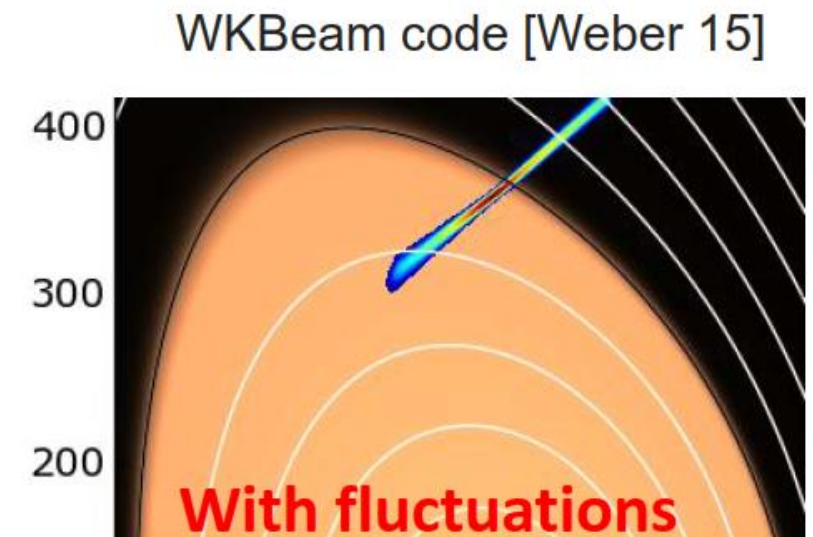
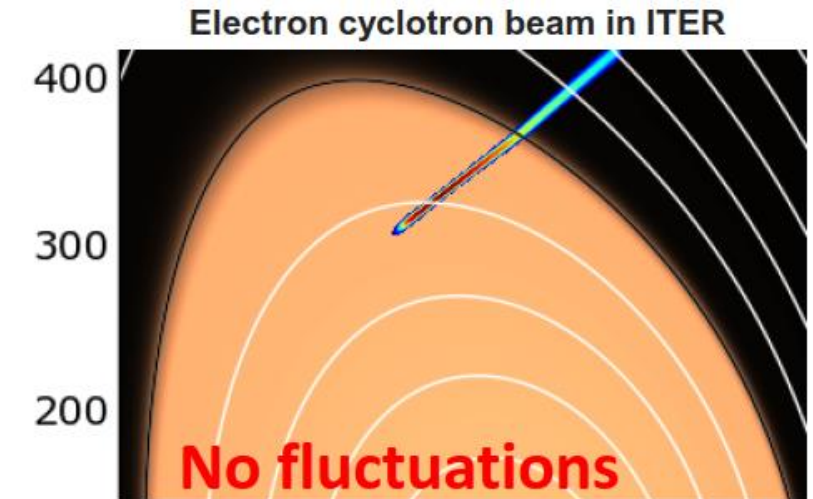

Beam broadening due to density fluctuations

- **Density fluctuations** act as random variations of the refractive index → radiation scattering and **beam broadening**
- Quantitative predictions through numerical solution of the wave kinetic equation: WKBeam code [Weber 15] ← statistically **averaged effect of fluctuations**
- **Significant broadening** and loss of stabilizing power **expected** for long propagation paths
- Conditions for minimizing the beam broadening not necessarily the same as for optimum current drive
- Example shown here: NTM stabilization with 27 MW from position 3 (**not full optimization!**)
- **Large uncertainty** on turbulence parameters (strength of the fluctuations, correlation length)

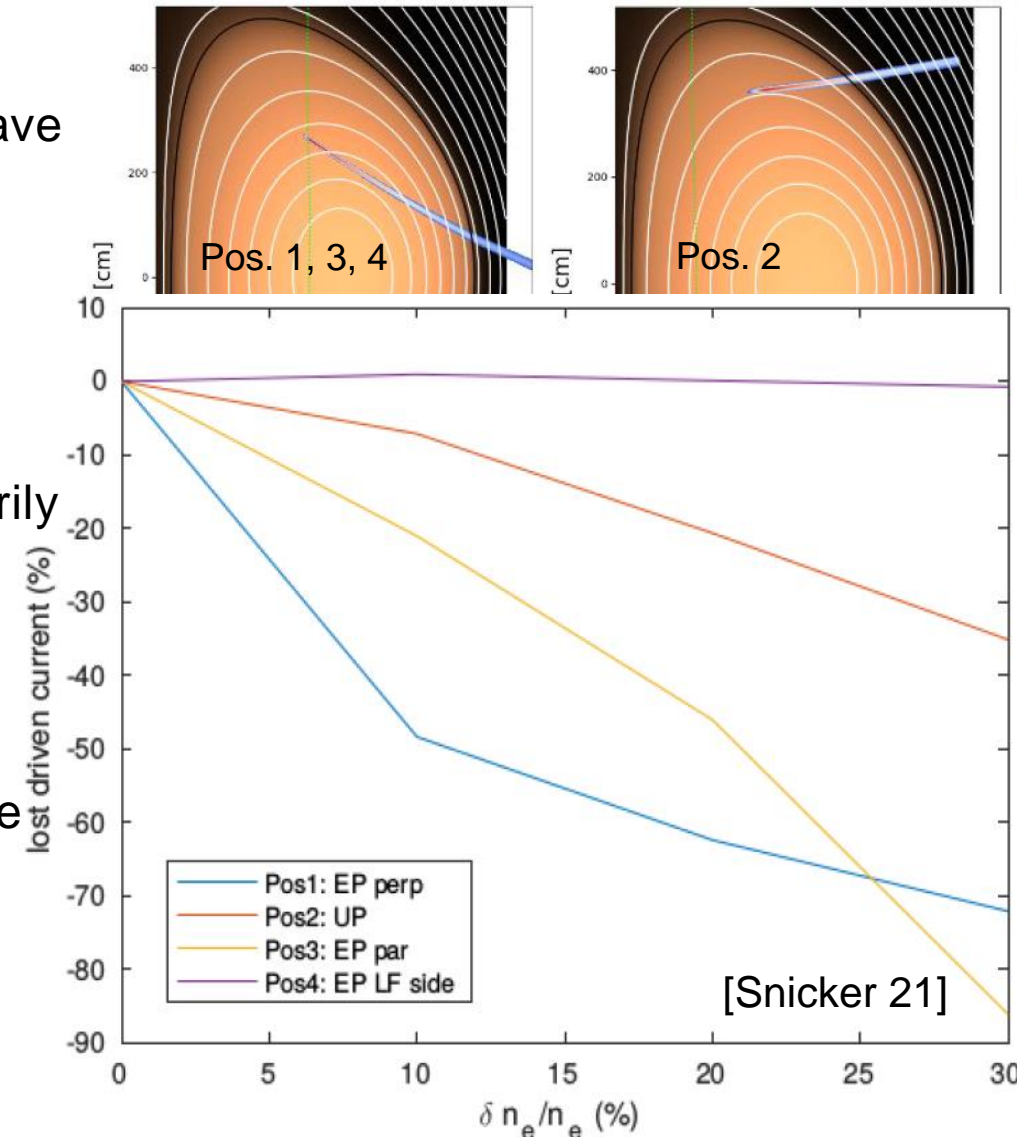

Control of radiative instability due to tungsten flake

- In the (unlikely) event of a significant amount of tungsten (0.01-0.1 g) crossing the separatrix, **electrons should not cool down too quickly** [Palermo 20] ← injection of EC waves foreseen
- Install more than 70 MW at 136 GHz with no other use?

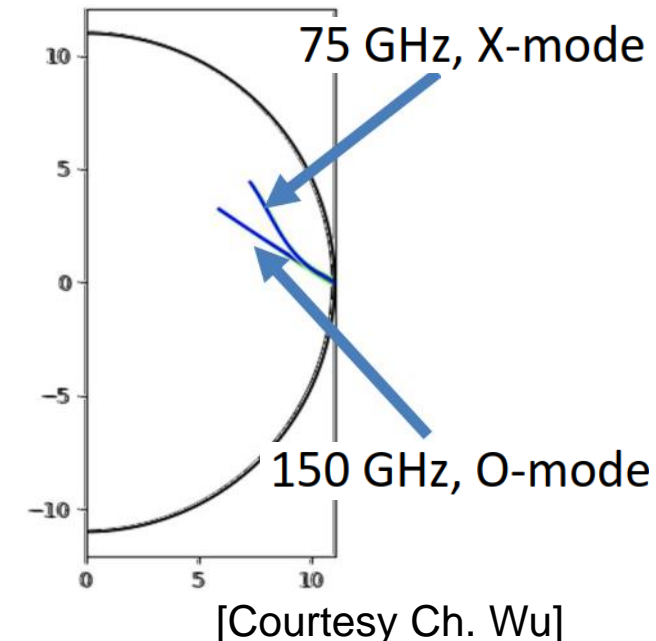
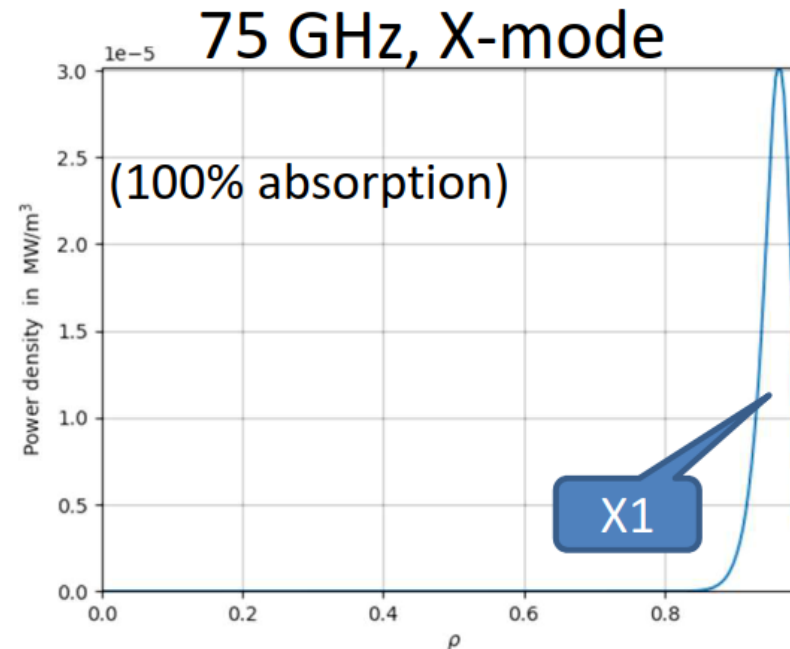
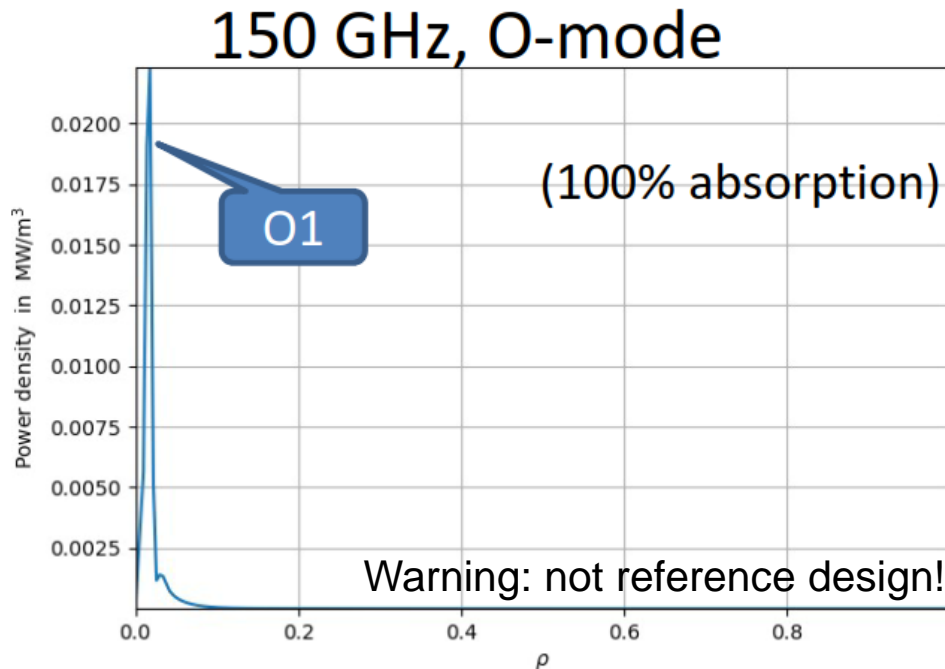

- Different options presently explored: **switch gyrotron harmonics** (150 GHz O1 in the centre, 75 GHz X1 at the edge) or keep frequency (150 GHz), change polarization (O1 in the centre, X2 at the edge)

Control of radiative instability due to tungsten flake

- In the (unlikely) event of a significant amount of tungsten (0.01-0.1 g) crossing the separatrix, **electrons should not cool down too quickly** [Palermo 20] ← injection of EC waves foreseen
- Install more than 70 MW at 136 GHz with no other use?

O-mode

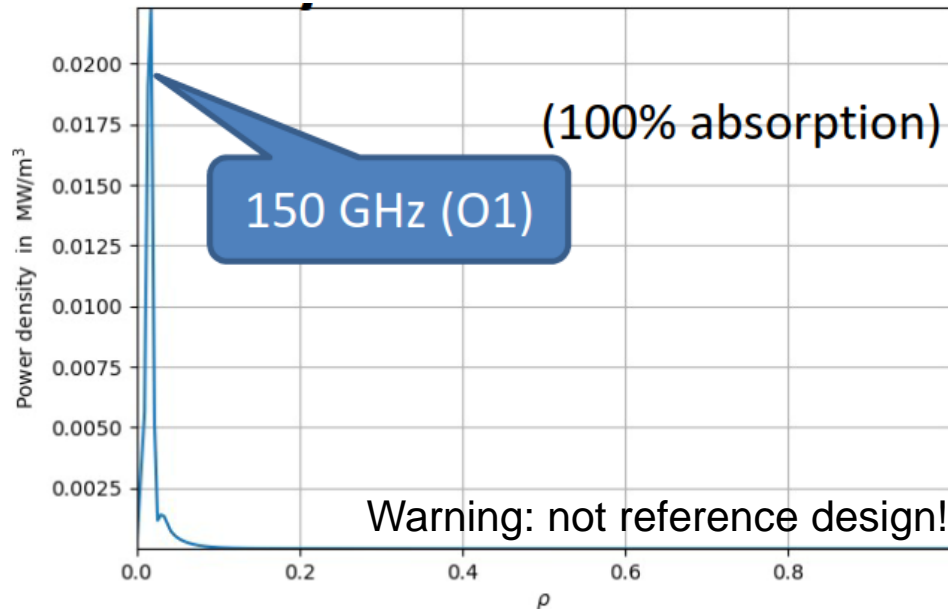

X-mode

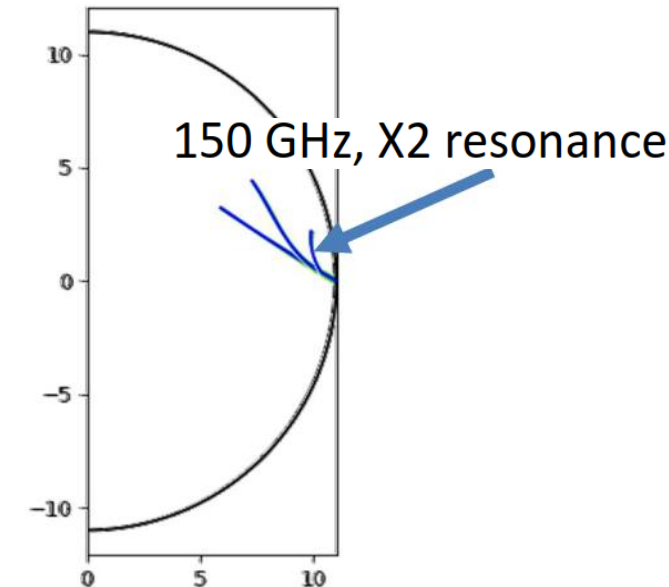
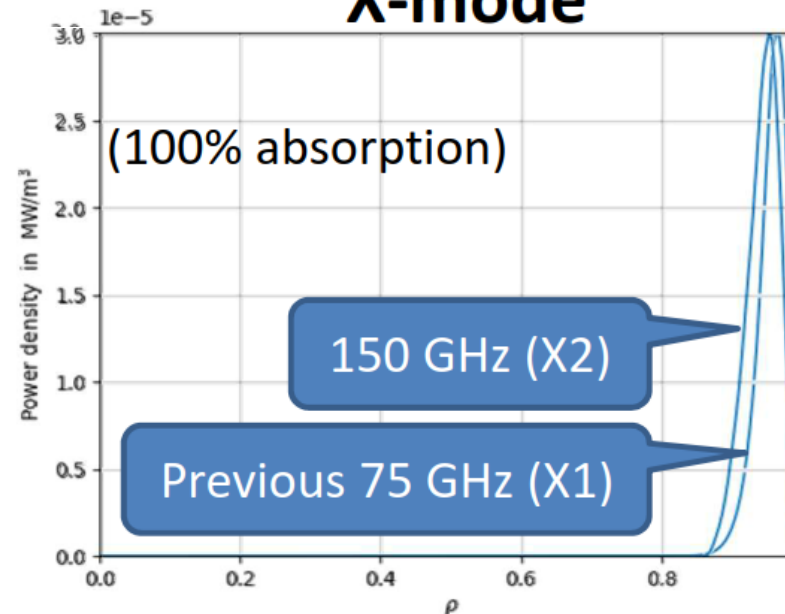

[Courtesy Ch. Wu]

- Different options presently explored: switch gyrotron harmonics (150 GHz O1 in the centre, 75 GHz X1 at the edge) or **keep frequency (150 GHz), change polarization** (O1 in the centre, X2 at the edge)



Back to the roots: optimize the ECCD efficiency

- Recent optimization exercise for a low-aspect ratio variant of DEMO: $R_0 = 7.5$ m, $a = 2.88$ m ($R/a=2.6$), $B_0 = 4$ T, $Z_{\text{eff}} = 1.5$

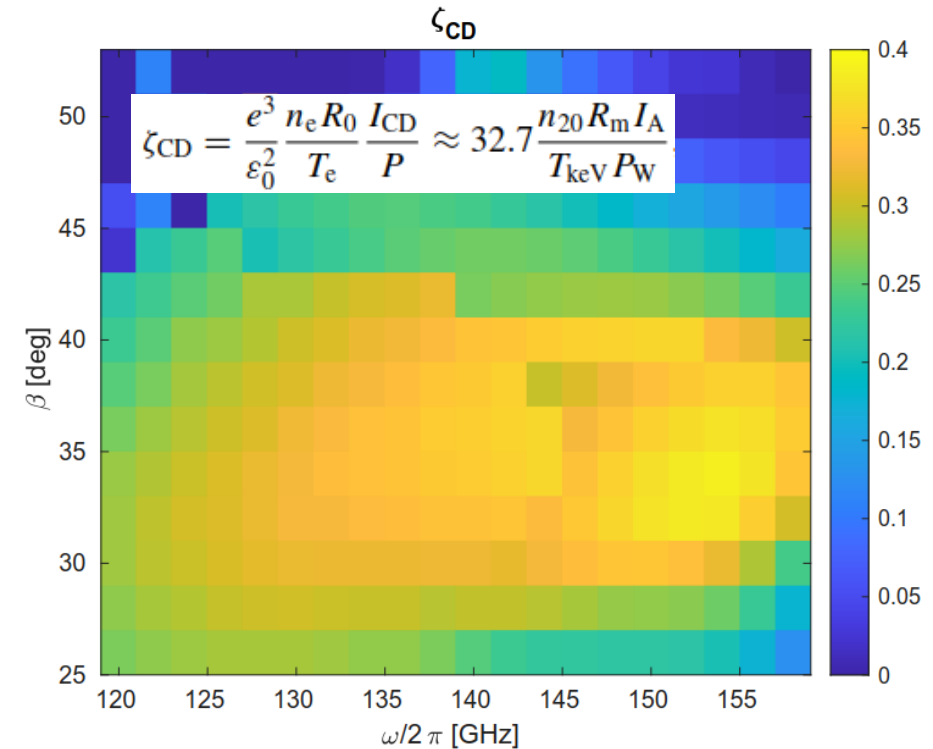
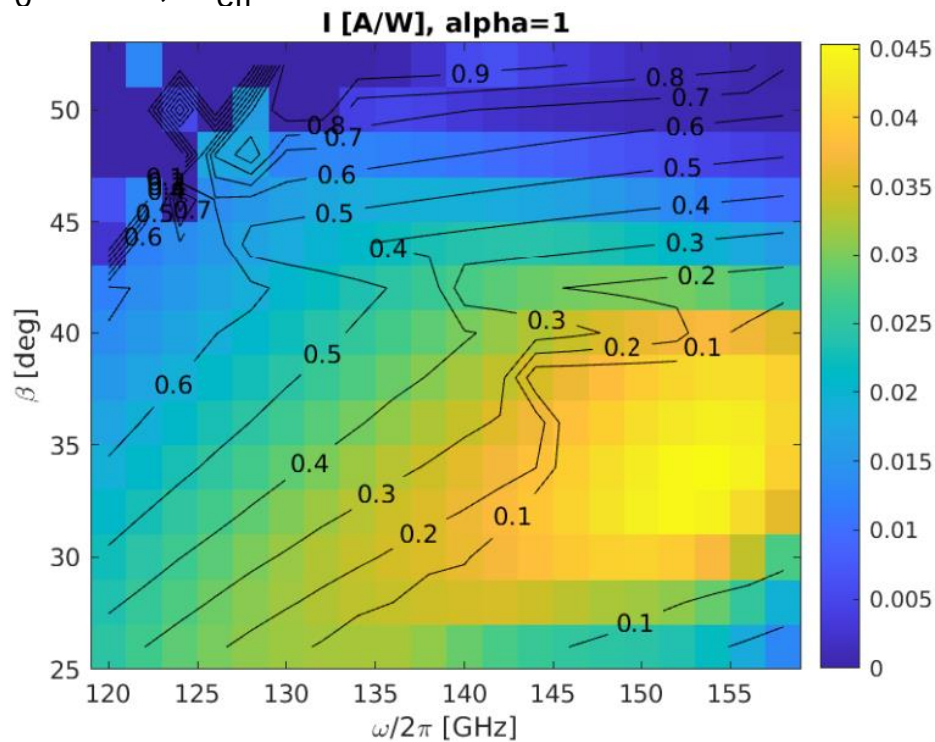

- Standard optimization from $(R,Z) = (11, 0)$ m consistent with usual picture, leads to max. 46 kA/MW
- 10-12% O2-absorption slightly larger than for standard aspect ratio (slightly closer harmonics)



Alternative scheme for the outer core / edge: (slow-)X1 absorption

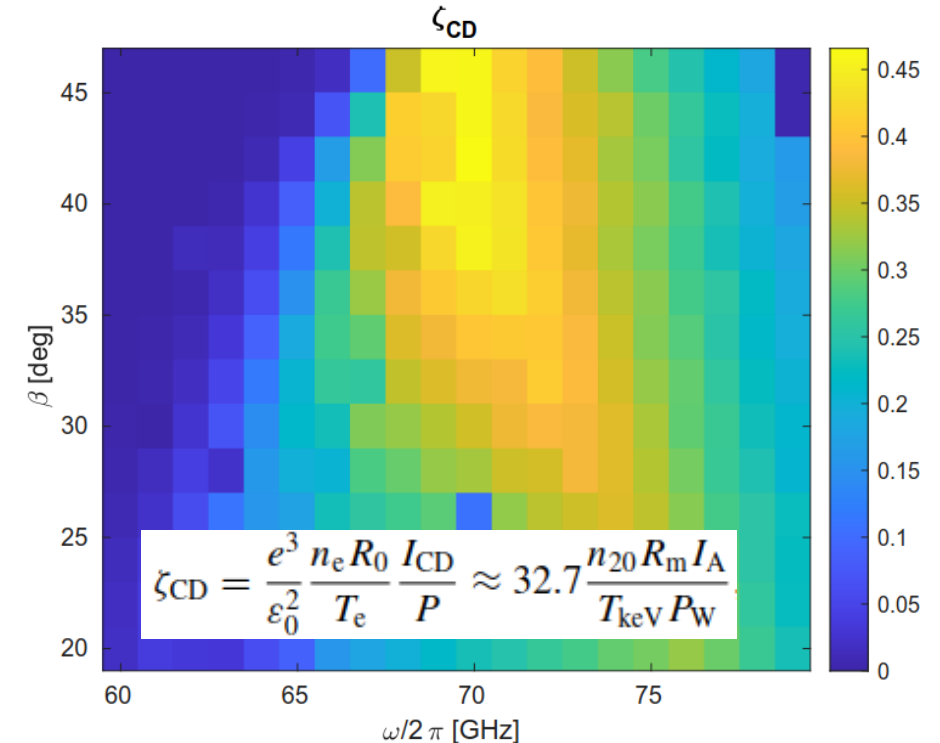
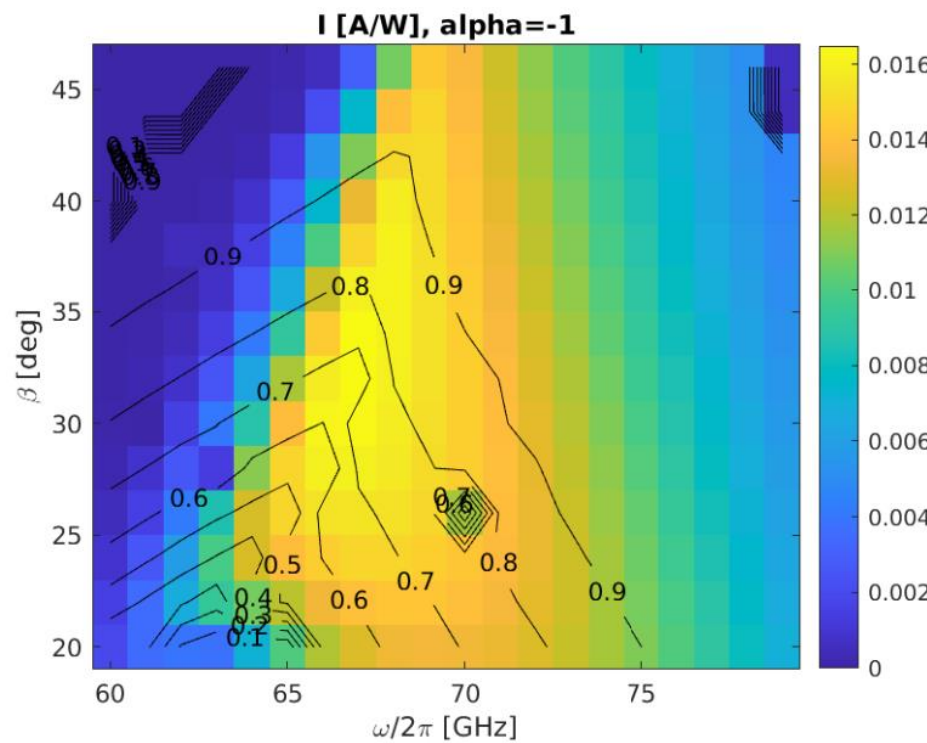
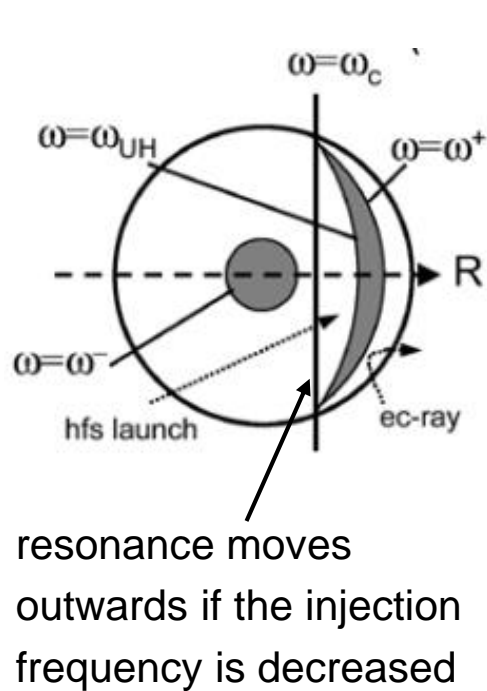

- **X1-scheme from LFS**: shift the resonance outside the plasma (LFS) by lowering the injection frequency, rely on Doppler shift → small operational window
- **Quite high efficiency** in the outer plasma, $\rho \sim 0.8 - 0.9$
- Preliminary studies show no particular advantage from top / HFS launch
- Promising theoretical results for STEP parameters [Figini EC21]



Summary

- Injection of electron cyclotron waves in a fusion reactor is very attractive from the physical and technological point of view
- Mature physics & technology: issues are mainly “complaining on a high level”
- Some applications (e.g. NTM stabilization) can be mastered likely only with ECCD
- Sustaining a steady state DEMO with ECCD only seems difficult according to present status of theory
- Open technology issues: RAMI issues, extensions to higher frequencies / power / efficiency (technology readiness?)
- Theory relevant for ECCD applications: better understanding of expected turbulence and NTM (small island) physics
- Specific ECCD-related topics: Warm plasma effects on propagation, role of quasi-linear modification of the distribution function, performance of Okawa current, efficient estimate of beam scattering, brilliant ideas to improve efficiency?...



The European DEMO [Fus. Eng. Des., Special Issue, 2022]

The high-level requirements for EU-DEMO are given as [3]:

- Produce substantial net electrical power (several hundred MWs) for substantial time (hours)
- Demonstrate tritium self-sufficiency
- Demonstrate the operation of supporting plant systems and materials capable of achieving commercial power plant operational availability
- Achievement of DEMO engineering design and evaluation on a timescale which provides continuity from ITER build and operation, i.e. operation in the 2050s

This has been interpreted to mean [4]:

- A target of 500MW net electrical power at flat-top. For the plant recirculating power assumptions and efficiencies of systems, this implies a plasma fusion power close to 2GW
- A pulse length of at least 2 h
- Sufficient room in the tokamak radial build for breeder blanket on both the inboard and outboard sides of the plasma

- A full remote maintenance scheme which can remove and replace in-vessel components from the vacuum vessel and move them to hot cell storage efficiently and in a way which will satisfy nuclear regulators of plant safety
- A closed fuel cycle which meets regulatory tritium release and inventory requirements, meaning exhaust treatment for isotopic separations as well as the installation of a breeder blanket
- A choice of materials, plasma scenario, and technologies which can be developed to sufficient maturity in the time available: this implies that they are available at least at lab-scale now (with technology readiness level, $TRL \geq 4$), rather than relying on speculative technologies or effects demonstrated only at the microscale
- It is foreseen that DEMO will utilise a first set of blankets (called “starter”) with a damage limit in the first-wall steel (EUROFER) of 20 dpa¹ and conservative design margins, and then switch to a second set of blankets aimed at a 50 dpa damage limit with an optimized design and, if available, improved structural materials that will need to be qualified in advance² [7]. An additional benefit of this “progressive” approach is the possibility of starting with a less optimized thermo-hydraulic or mechanical design (i.e. with larger safety margins) to cope with large uncertainties in the overall reactor loadings and performances
- DEMO is also planned to play the role of a “component test facility” for the breeding blanket. As such, its design must incorporate the ability and the flexibility to accommodate the testing of at least one type of advanced tritium breeding blanket concept with the potential to be deployed in a first-of-a-kind fusion power plant

[Kembleton 22]



The relativistic resonance condition

- Fundamental role of **relativistic effects** (Lorentz factor $\gamma = \sqrt{1 + u_{\parallel}^2 + u_{\perp}^2}$) and **Doppler shift**

$$\omega - \frac{n\Omega_e}{\gamma} - k_{\parallel}v_{\parallel} = 0 \quad \rightarrow \quad \gamma - n\bar{\Omega} - N_{\parallel}u_{\parallel} = 0 \quad \text{with } \bar{\Omega} = \Omega_e/\omega \text{ and } u = \gamma v/c$$

- Resonance curves **in velocity space** are **ellipses** intersecting the u_{\parallel} axis at

$$u_{\parallel,\mp} = \frac{nN_{\parallel}\bar{\Omega} \mp \sqrt{n^2\bar{\Omega}^2 - (1 - N_{\parallel}^2)}}{1 - N_{\parallel}^2}$$

- For low-field-side injection: resonance possible before cold resonance (Doppler shift) if $n\bar{\Omega} \geq \sqrt{1 - N_{\parallel}^2}$
- Pinch point (first point in resonance) [Harvey 97]

$$u_{\parallel-} = u_{\parallel+} = \frac{N_{\parallel}}{\sqrt{1 - N_{\parallel}^2}} \equiv u_{\parallel,pp}$$

- Increasing N_{\parallel} **moves the absorption location** to the LFS and **shifts the resonance on more energetic** (less collisional) **electrons** \rightarrow higher current drive efficiency, weaker absorption

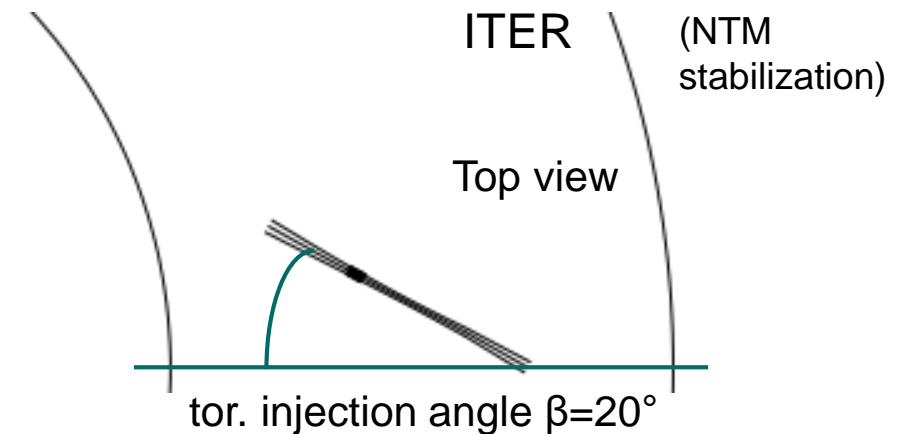



* An EC-only DEMO?

- The technological advantages of the EC system suggest the possibility of a purely EC-heated DEMO
- **LH transition can be achieved with pure EC** wave heating if impurity content are below a (density dependent) threshold
- Ion heat flux **more sensitive** (through $T_e - T_i$) than P_{LH} **to the effect of impurities** in the LH transition

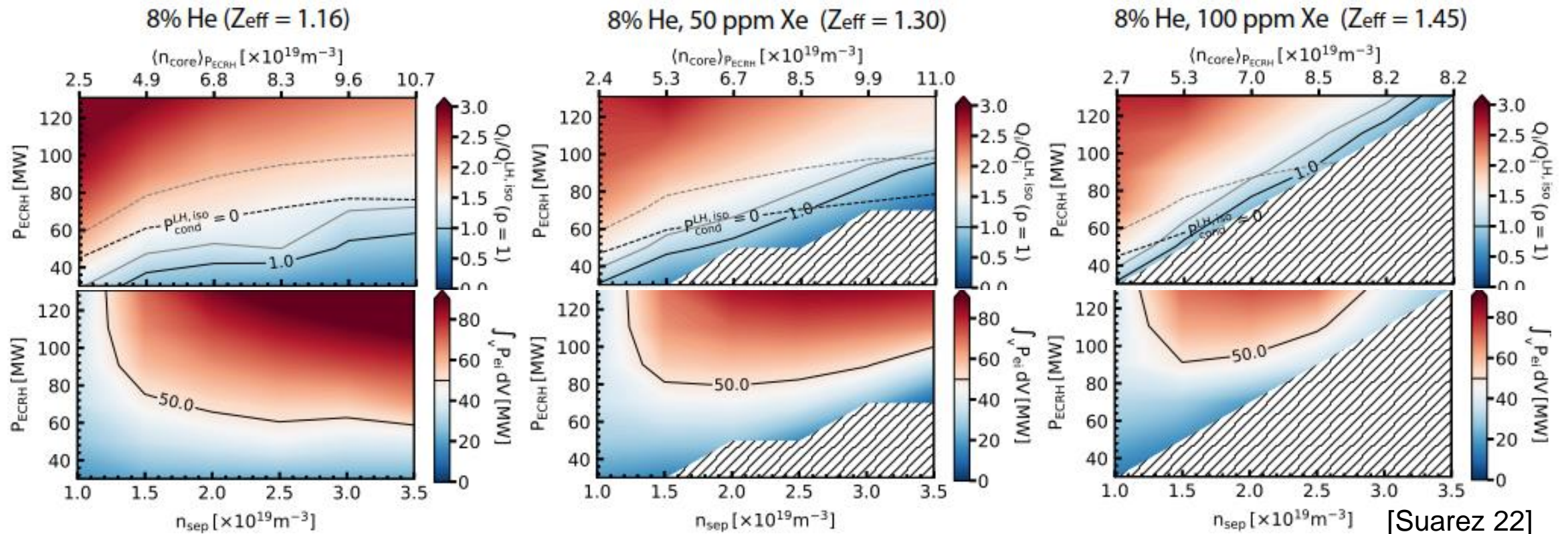



* The European DEMO [Fus. Eng. Des., Special Issue, 2022]

- The present design point is a **trade-offs between the most mature knowledge in physics and technology**, the emphasis on the problem of the **power exhaust** and the attention given to **nuclear design integration**, and “not an a priori desire to be big” [Kembleton 22].
- Main factor setting the machine size: **power exhaust** and **magnet performance**

- Limit on power tolerated at reattachment (use simplified Eich scaling)

$$q_{\text{target}} \propto \frac{P_{\text{sep}} B_p}{R} \propto \frac{P_{\text{sep}} B_t}{q_{95} A R} < \frac{P_{\text{sep}} B_t}{q_{95} A R} \Big|_{\text{ref}}$$

- Limit on concentration of divertor radiator (Reinke scaling)

$$c_{\text{detach}} \propto f_{\text{LH}}^{1.14} B_t^{0.88} R^{1.33} < c_{\text{ref}}$$

- Fix A, P_{fus} , q_{95} , f_{GW} ; use IPB98(y,2) and Martin scaling for $P_{\text{LH}} = P_{\text{sep}} / f_{\text{LH}}$

$$\frac{P_{\text{sep}} B_t}{q_{95} A R} \propto f_{\text{LH}} R^{-1.5} \quad c_{\text{detach}} \propto f_{\text{LH}}^{1.14} R^{0.75}$$

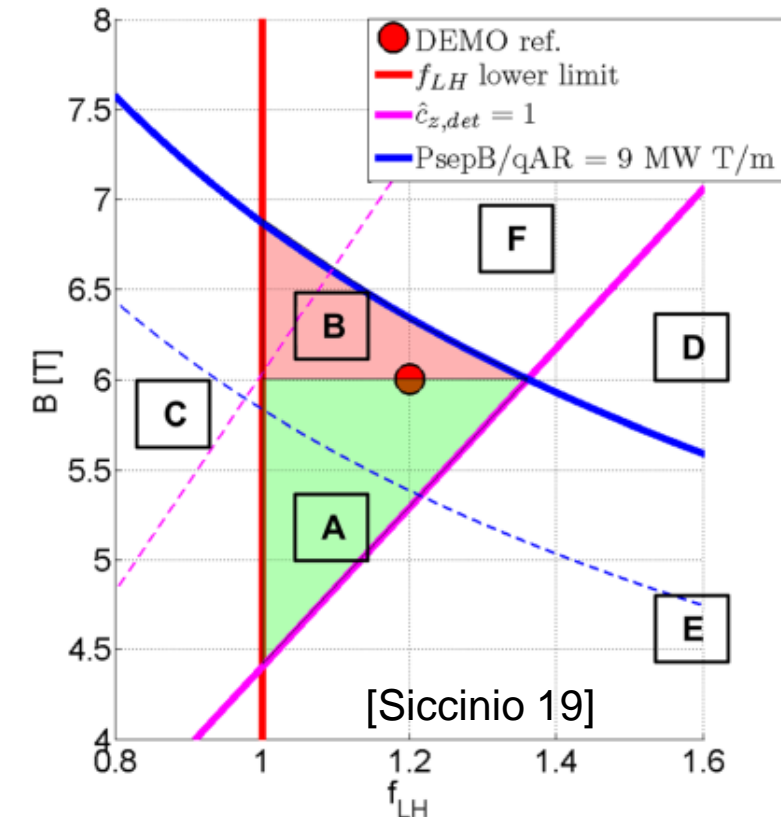
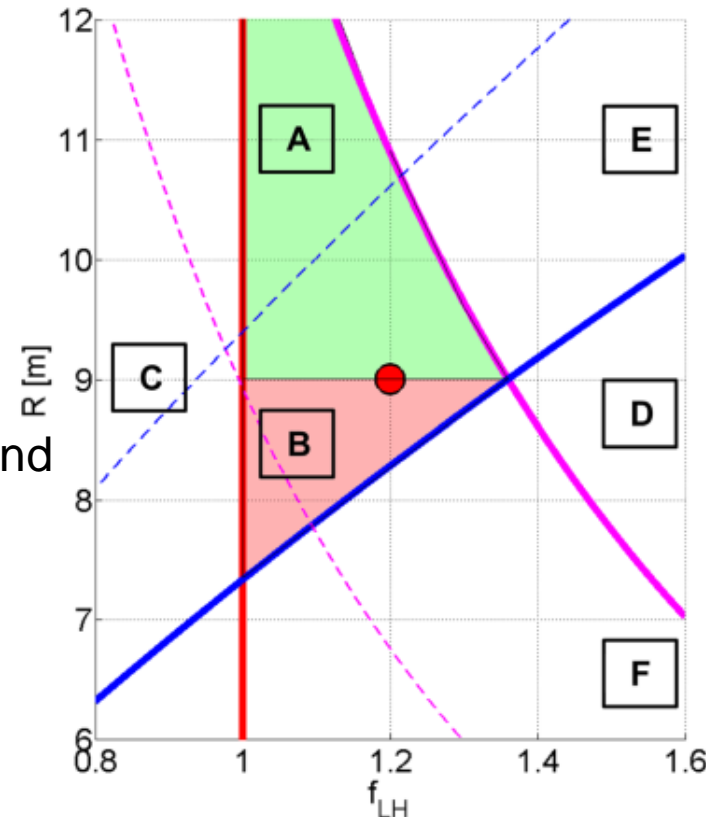

[Siccinio 19]

* Electron Cyclotron Waves

- Two big advantages for theory: **short (mm-range) wavelengths** (geometric-optics or WKB limit [Bernstein 75]), **linear theory** works well in many cases [Harvey 89] → allow very efficient calculations
- Waves **absorbed around the cyclotron resonance** or a harmonic of it
- Propagation calculated with cold-plasma model: Typical choices for polarization and frequencies: ordinary mode resonating at the electron cyclotron frequency (O1) and extraordinary mode at twice the cyclotron frequency (X2)

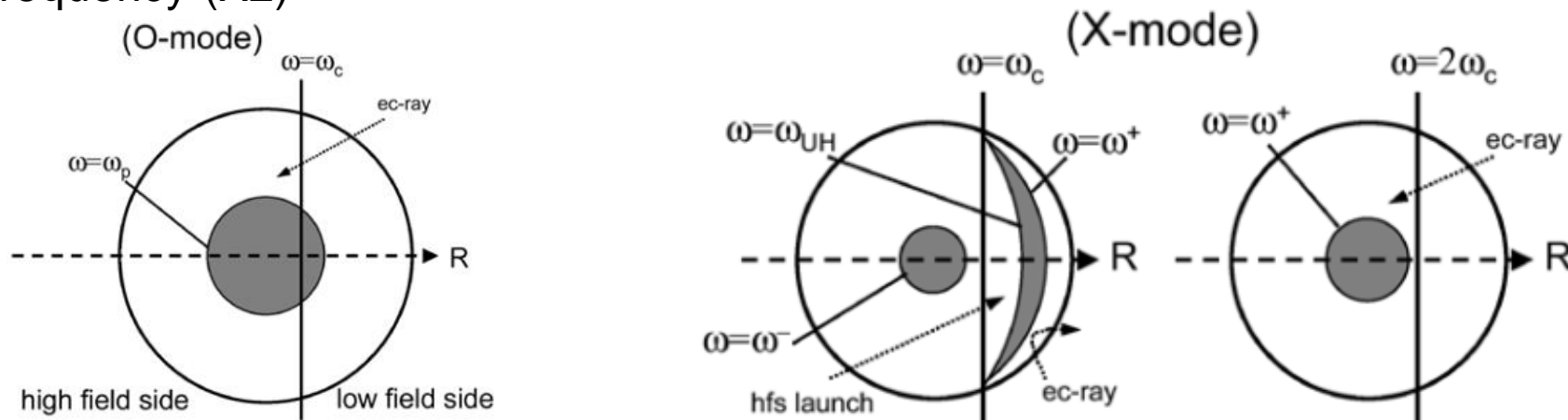

[Westerhof 12]

- X1 access from the low-field side problematic (cut-off on the way to the resonance)
- O1 typical scheme of choice in ITER and DEMO** ← wave frequency well above cut-off conditions for high field, standard-aspect-ratio tokamaks



* Electron Cyclotron Waves

- Breakdown of linear theory [Harvey 89] when p [MW/m³] > 0.5 (n_{19} [m⁻³])² ← might be relevant for on-axis deposition at high power > 50 MW

- Cold-plasma approximation valid if

$$\frac{k_{\perp}^2 v_{\text{th},e}^2}{\Omega_e^2} \ll 1 \quad \text{and} \quad \left| \frac{\omega - n\Omega_e}{k_{\parallel} v_{\text{th},e}} \right|^2 \gg 1$$

- First condition requires the electron Larmor radius (0.01-0.1 mm) being much smaller than the wavelength (mm)
- Second condition might be violated if the wave approaches the cold resonance at finite Doppler shift (a scenario one wants to avoid for ECCD but cannot be excluded)

Outline

- What is the European DEMO actually? (basic considerations and different options, e.g. pulsed vs. steady state)
- DEMO vs. ITER: reactor prototype vs. physics experiment (also: where do we put the EC port? optimize functionality vs. design requirements)
- Theoretical background: resonance condition and ECCD efficiency
- ECCD for bulk current drive → how to optimize the efficiency
- ECCD for stabilization of neoclassical tearing modes → different requirements on frequency
- Recent developments (wave scattering, thermal instability, X1 at the edge, ... ?)
- An EC-only DEMO?

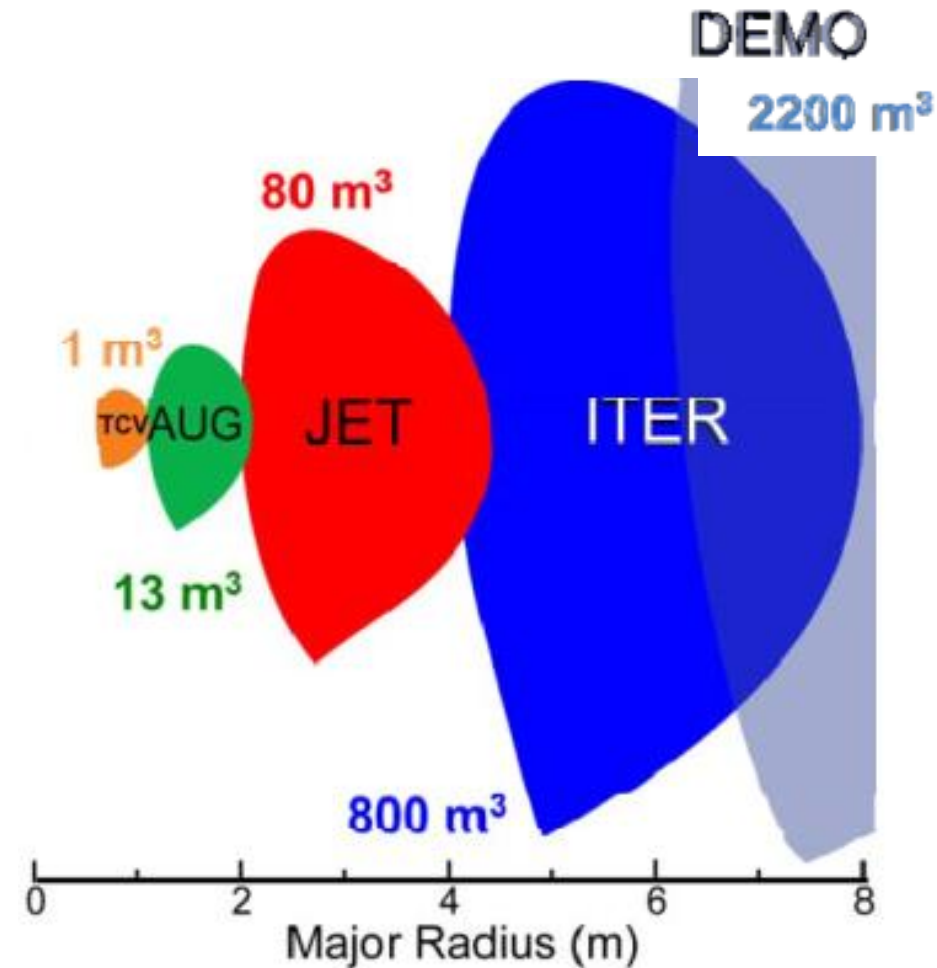

[Ciattaglia IEEE Conf. 17]



The European DEMO [Fus. Eng. Des., Special Issue, 2022]

- The present EU DEMO designs, and in particular the size which is being considered, is a result of a systematic exploration of the design space, the consequence of **trade-offs between the most mature knowledge in physics and technology**, the emphasis on the problem of the **power exhaust** and the attention given to **nuclear design integration**, and “not an a priori desire to be big” [Kembleton 22].
- Main factor setting the machine size: **power exhaust** and **magnet performance**
- Check papers Kembleton, Siccinio in FED (add figure?)
- Paper NF Mattia with radiation constraints (add figure?)

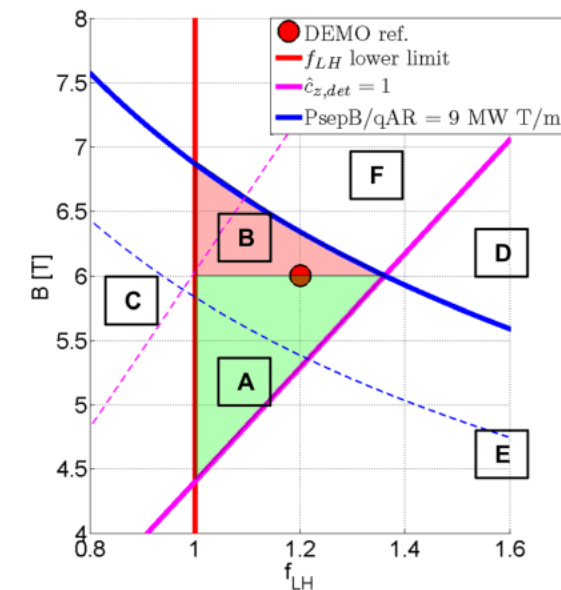
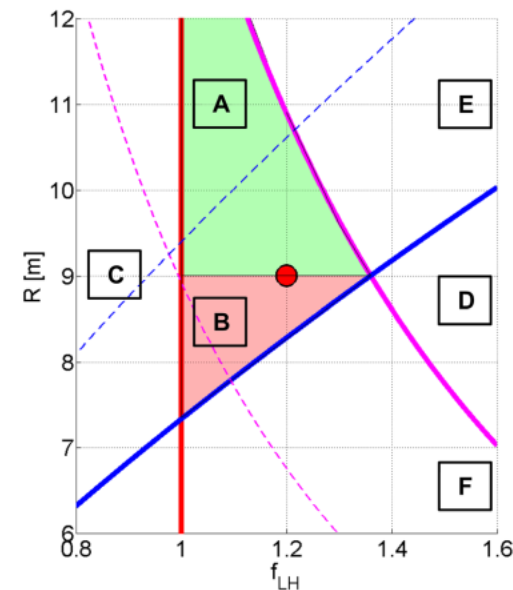

Optimizing the bulk current drive in DEMO

- Fundamental question: **How much current can be driven** by EC waves?
- Direct answer for a given scenario by **scanning the parameter space** (injection position, injection angles, wave frequency)
- First example [Poli 13]

DEMO model	B (T)	R (m)	R/a	I_p (MA)	n_{e0} (10^{19} m^{-3})	T_{e0} (keV)
Steady-state (peaked/flat n_e)	5.84	8.5	3	19.1/22.8	15.0/9.3	53/64
Pulsed (peaked/flat n_e)	7.45	9.6	4	14.4/17.3	16.8/10.4	57/54

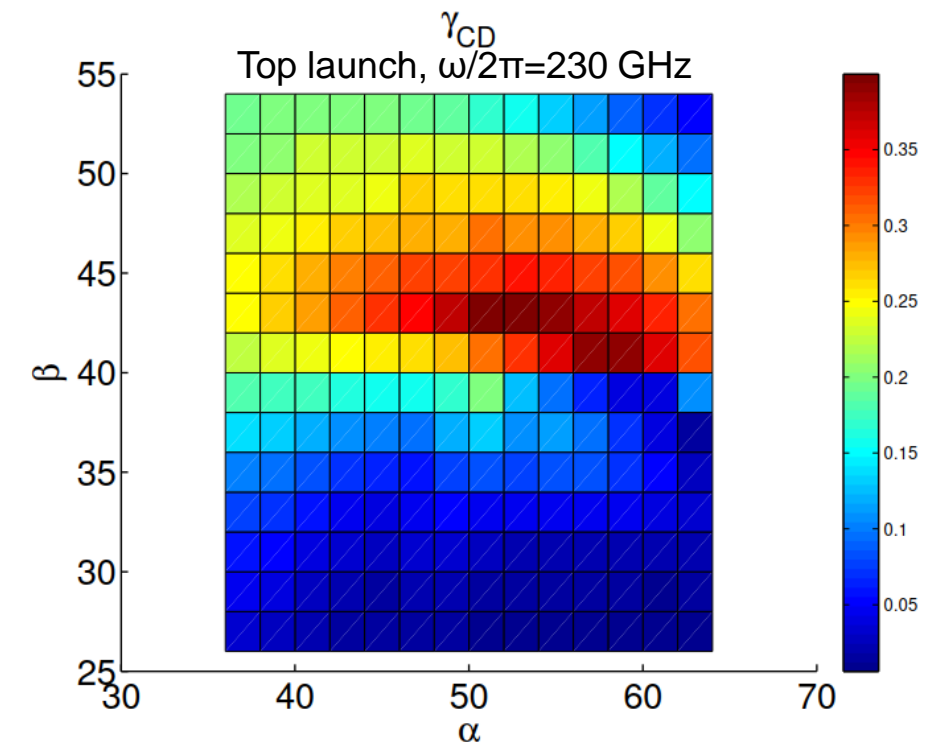
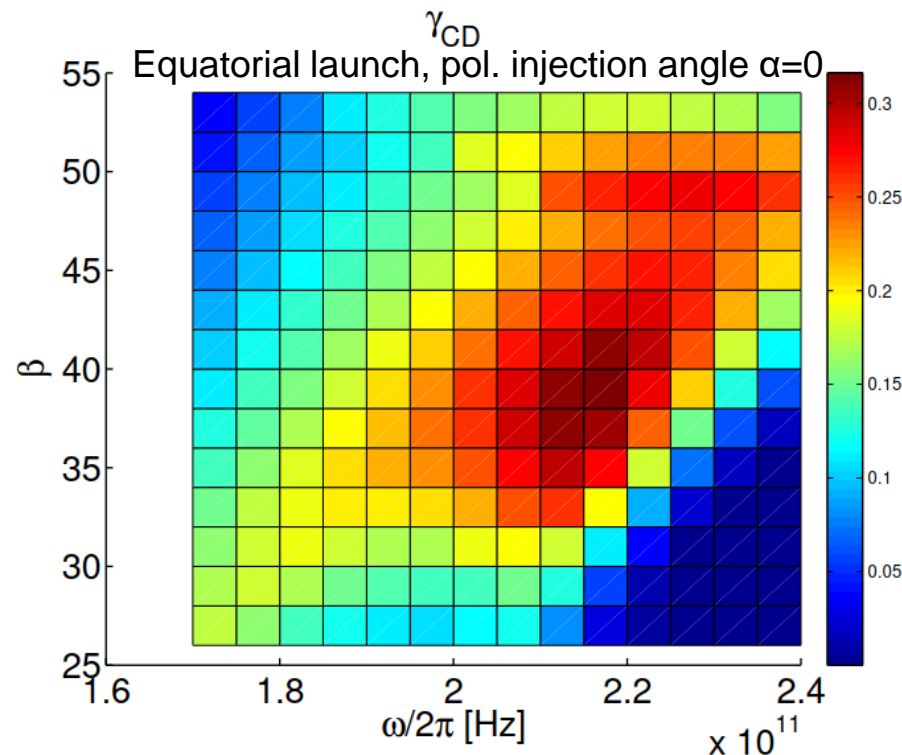

$$\gamma_{CD} = \frac{n_{20} R_m I_A}{P_W}$$



Stabilization of Neoclassical Tearing Modes

- Reminder: the **maximization of the total ECCD current leads to broad profiles** (in general beyond optimum width for NTM stabilization)
- **Lower $N_{||}$** and **lower frequency** expected for optimum NTM control with respect to maximum ECCD case
- Favourable settings **beam focused on** and **tangent to** the relevant flux surface at absorption location
→ allow to increase the total current without overly widening the deposition profile
- More central $q=3/2$ and $q=2$ surface have in generally higher ECCD efficiency



* HARE (Hare Analyses Reactor ECCD)

- The module returns the **estimated optimum current drive efficiency** and **driven current (per unit power)** for given values of density, electron temperature, magnetic field, minor and major radius, ρ and Z_{eff}
 - The ECCD efficiency is calculated numerically [Lin-Liu 03; Marushchenko 08] ← **requires wave frequency and parallel wave vector** as an input
 - Requires three conditions for the three quantities ω , N_{\parallel} , $u_{\parallel-}$ (approximate $\gamma = \sqrt{1 + u_{\parallel}^2 + u_{\perp}^2} \simeq \sqrt{1 + u_{\parallel-}^2}$)
 - **width of absorption profile** (only “tuning parameter”, justified from theory & simulations): $\Delta\rho=0.2$
- this fixes the **energy of resonant electrons at absorption peak** and hence $u_{\parallel-}$: $mc^2 \left(\sqrt{1 + u_{\parallel-}^2} - 1 \right) = f_T T_e$
- **resonance condition** $N_{\parallel} = \frac{1}{u_{\parallel-}} \left(\sqrt{u_{\parallel-}^2 + 1} - \frac{n\Omega}{\omega} \right)$
 - **pinch point definition**

$$\frac{\omega}{n\Omega_0} \sqrt{1 - N_{\parallel}^2} = \frac{R_0}{R_0 + a \cos \theta \Delta\rho}$$
 (also fixed through the choice of $\Delta\rho$)
 - Combine last two expressions → **frequency shift**: $\frac{\omega}{n\Omega_0} = \sqrt{u_{\parallel-}^2 + 1} + |u_{\parallel-}| \sqrt{1 - \left(\frac{R_0}{R_0 + a \cos \theta \Delta\rho} \right)^2}$

* HARE (Hare Analyses Reactor ECCD)

- More **detailed analysis supports simplified model**

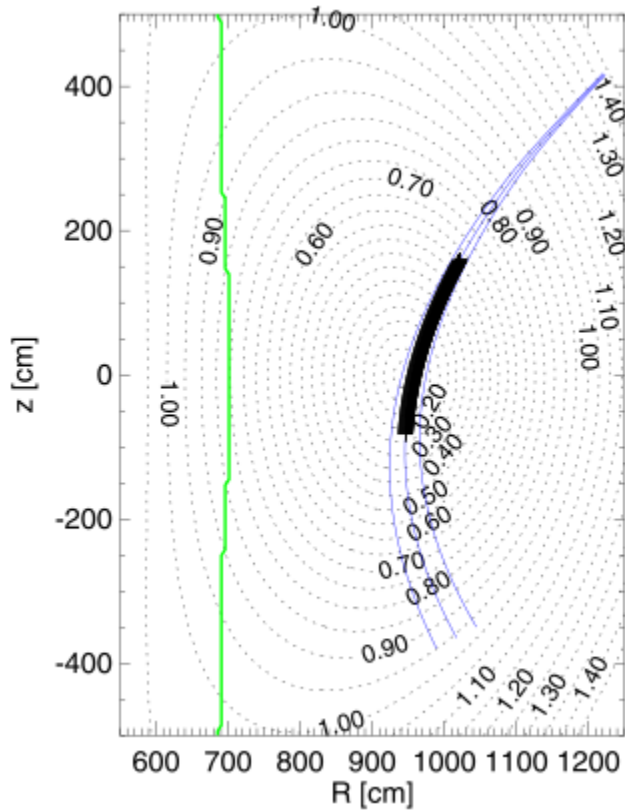

R_0 (cm)	a (cm)	B_0 (T)	n_{e0} (10^{19} m^{-3})	T_{e0} (keV)	Z_{eff}
907	292	5.66	10.50	33.25	2.0

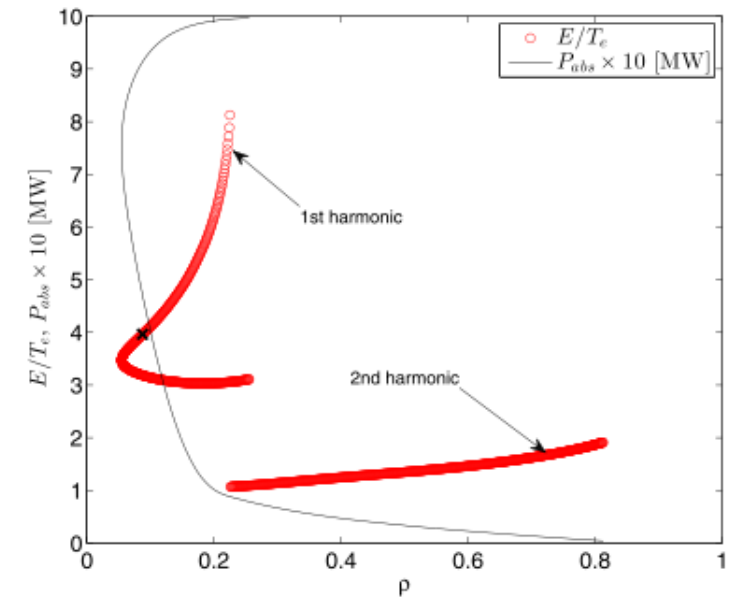
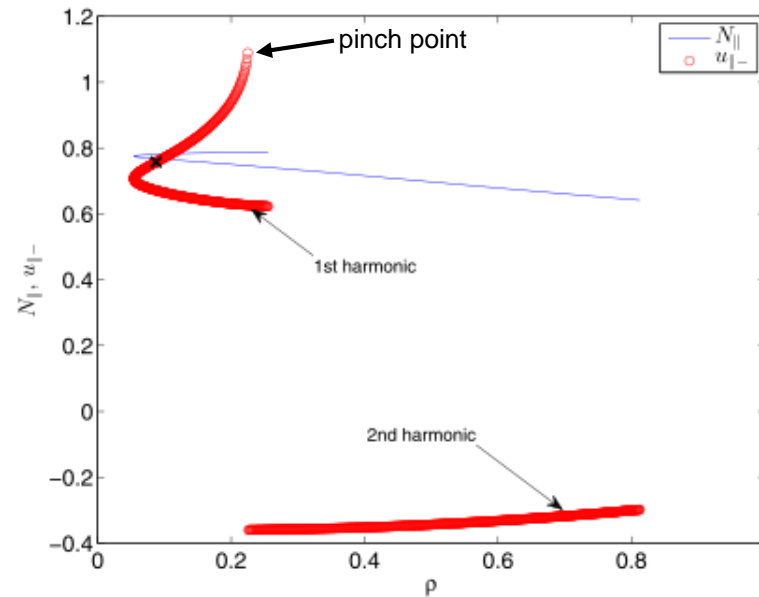

[Poli 18]

- Maximum-ECCD scenarios often exhibit ca.10% parasitic absorption (price to pay for large $N_{||}$)

* HARE (Hare Analyses Reactor ECCD)

- More **detailed analysis supports simplified model**

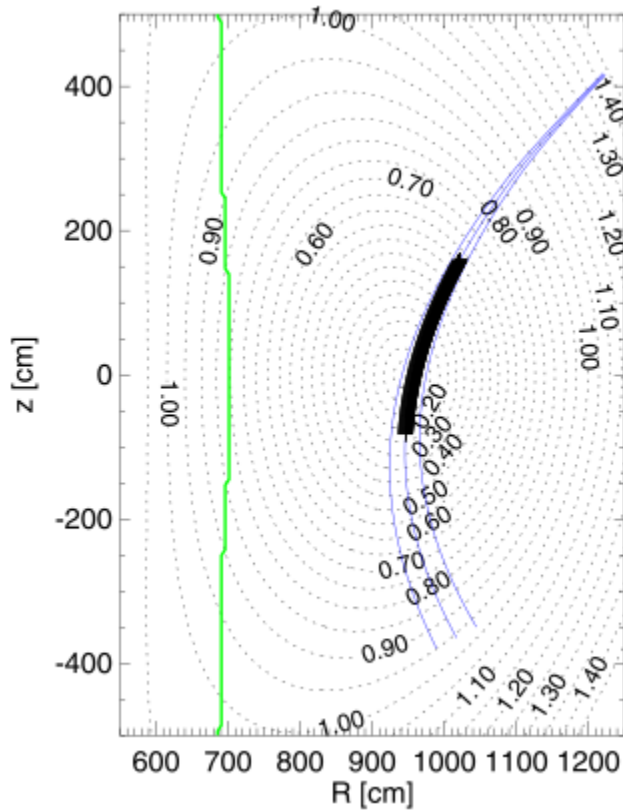

R_0 (cm)	a (cm)	B_0 (T)	n_{e0} (10^{19} m^{-3})	T_{e0} (keV)	Z_{eff}
907	292	5.66	10.50	33.25	2.0

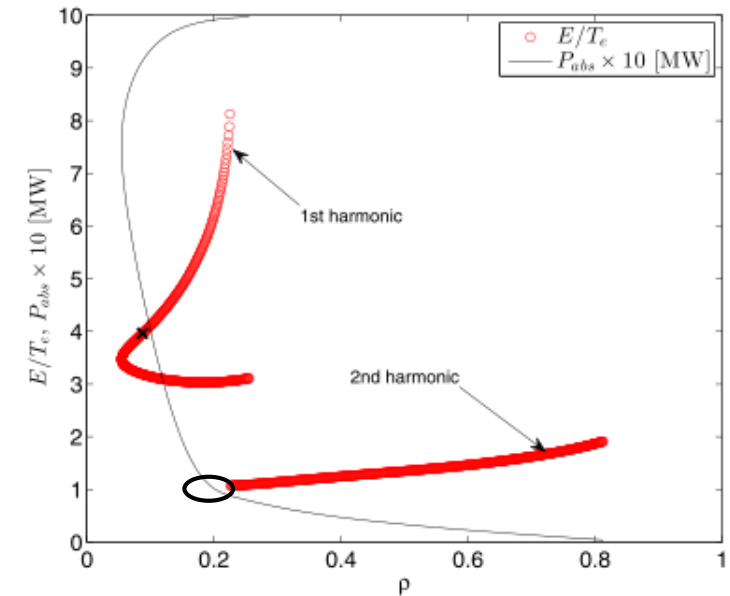
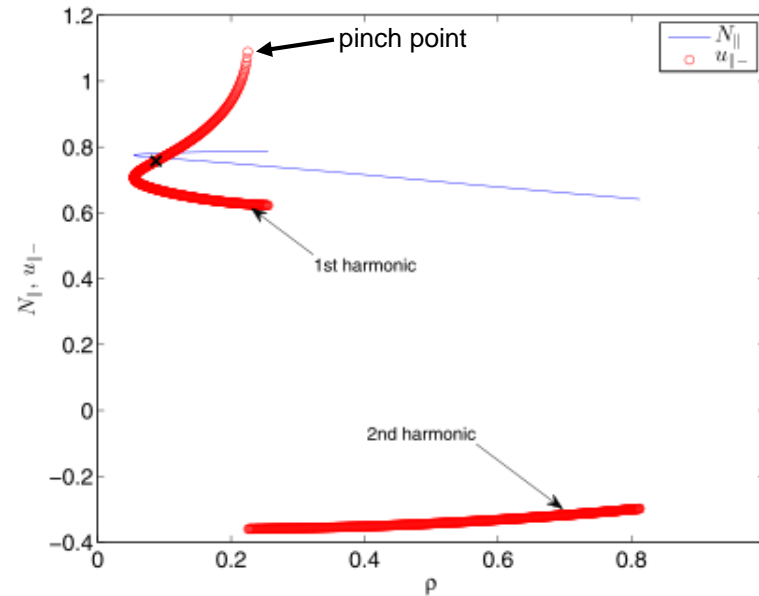

[Poli 18]

- Maximum-ECCD scenarios often exhibit ca.10% parasitic absorption (price to pay for large $N_{||}$)
- Absorption might be still dominated by second harmonic even when first harmonic becomes accessible

* HARE (Hare Analyses Reactor ECCD)

- More **detailed analysis supports simplified model**

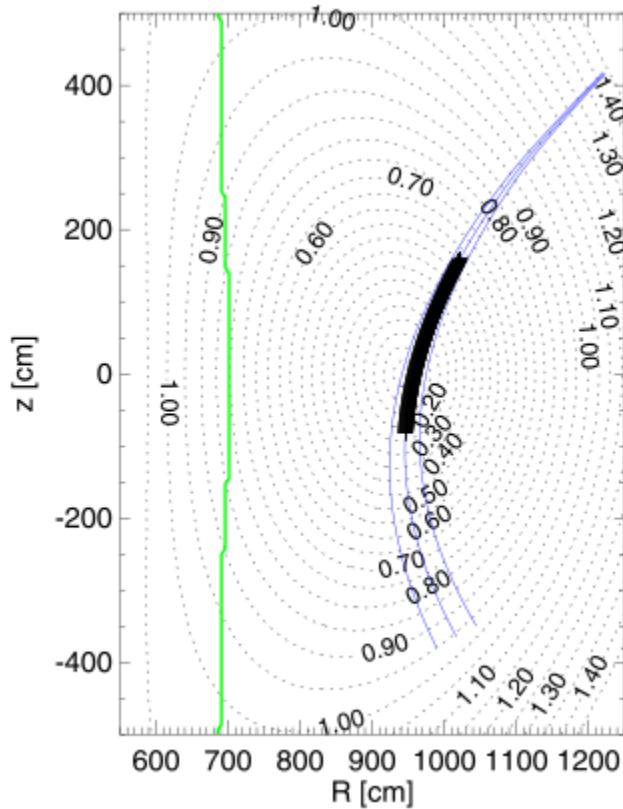

R_0 (cm)	a (cm)	B_0 (T)	n_{e0} (10^{19} m^{-3})	T_{e0} (keV)	Z_{eff}
907	292	5.66	10.50	33.25	2.0

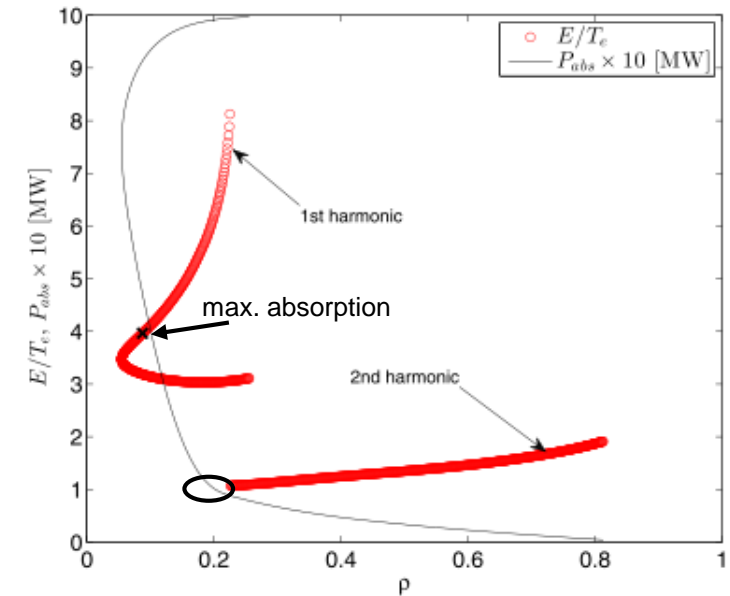
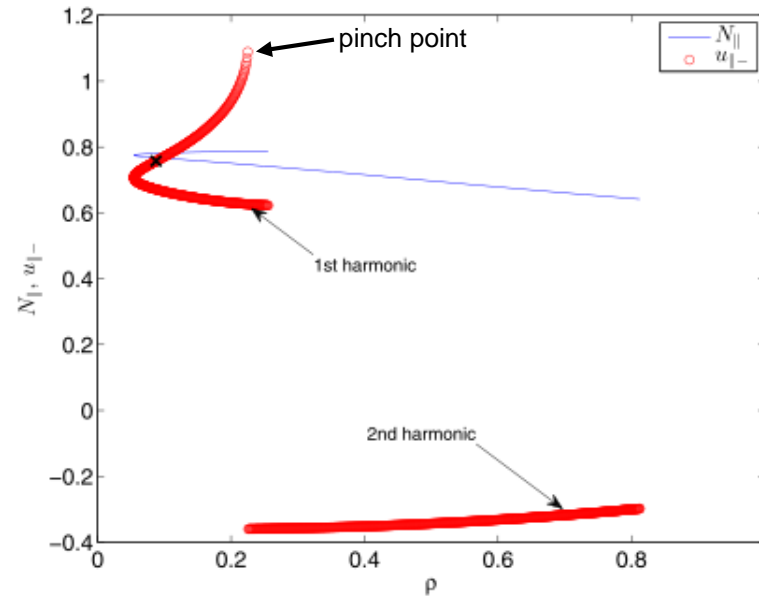

[Poli 18]

- Maximum-ECCD scenarios often exhibit ca.10% parasitic absorption (price to pay for large $N_{||}$)
- Absorption might be still dominated by second harmonic even when first harmonic becomes accessible
- Typical energy of resonant electrons at maximum ECCD ca. 4 times the temperature

Stabilization of Neoclassical Tearing Modes

- The Neoclassical Tearing Mode (NTM) is a reconnecting magnetic perturbation **driven unstable by the bootstrap current perturbation** due to pressure flattening

- NTM evolution described by the **generalized Rutherford equation**

$$\frac{dW}{dt} \propto \Delta' + \Delta'_{bs} + \Delta'_{ECCD} + \dots$$

- ECCD can be used to locally replace the missing bootstrap current

$$\frac{dW}{dt} \propto -1 + \frac{W_{sat}}{W} - 5 \frac{W_{CD} W_{sat}}{W^2} \frac{j_{CD}}{j_{bs}} \eta_{CD}$$

- Set left-hand side to zero, require that no solutions exist

$$\frac{W_{CD}}{W_{sat}} \frac{j_{CD}}{j_{bs}} \eta_{CD} > \frac{1}{20}$$

(caveat: the “CD stabilization efficiency” η_{CD} depends on W)

- Criteria employed to assess the stabilization efficiency of the ITER EC system:

- $j_{CD}/j_{bs} > 1.2$ (“large” W_{CD} , assumes ECCD modulation) [Zohm 07]

- $W_{CD} j_{CD}/j_{bs} > 5$ cm (“small” W_{CD}) [Sauter 10]

- The analysis leads to an “optimum” EC profile width $W_{CD}=5/1.2=4.2$ cm (ITER)

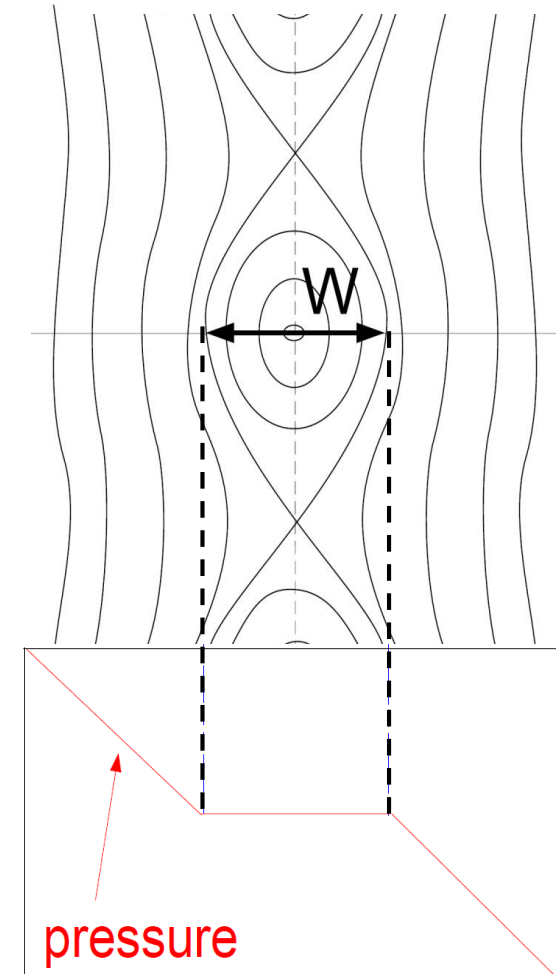



Achievable current with EC waves in Low-aspect-ratio DEMO

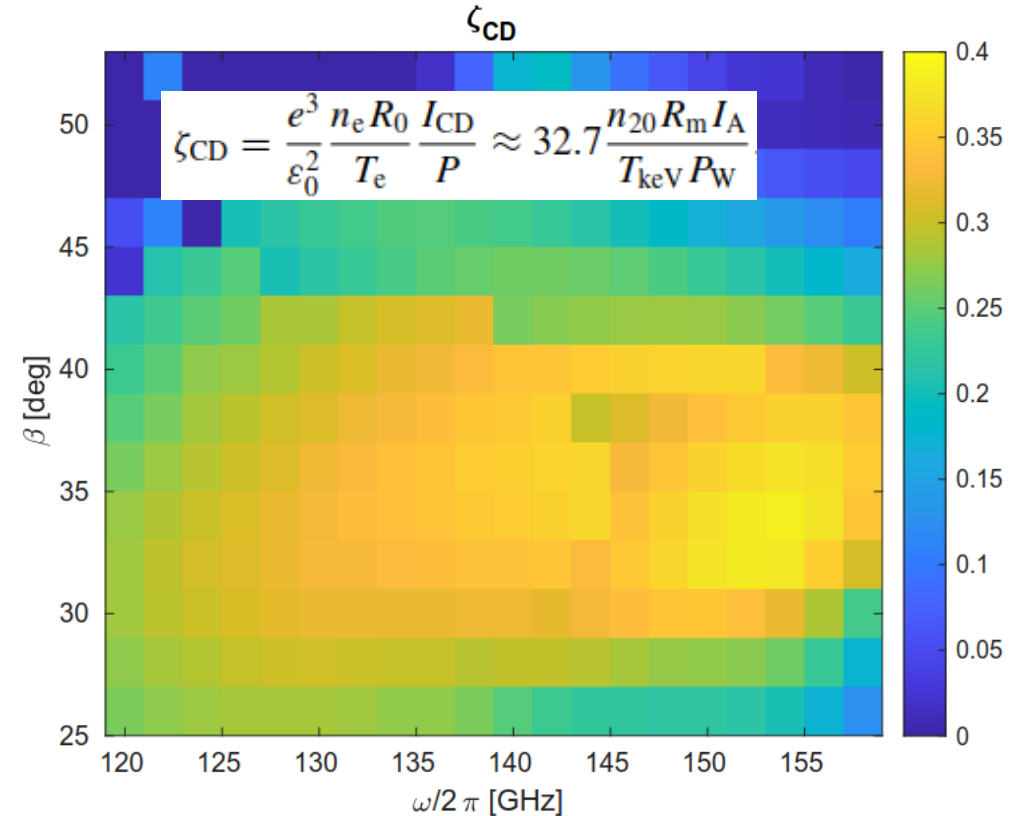
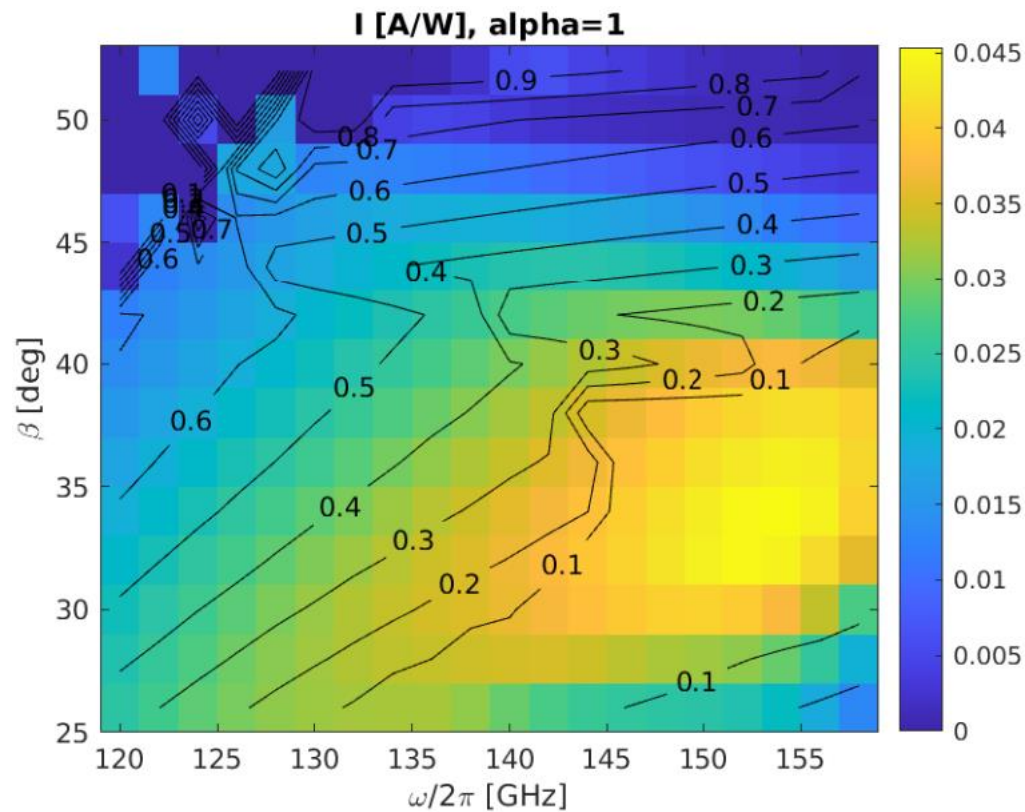

- Injection from (R,Z) = (11, 0) m, scan in toroidal injection angle and frequency
- More extensive parameter scans performed by Chuanren Wu (injection from R=11,95 m): maximum ECCD 46 kA/MW for freq. = 153.5 GHz
- Harmonic overlap (O2 parasitic absorption) of the order of 10-12% at optimum injection conditions (slightly higher than in “standard” aspect ratio cases), becomes dominant for X2-X3



Alternative scheme for the outer core / edge: X1 absorption

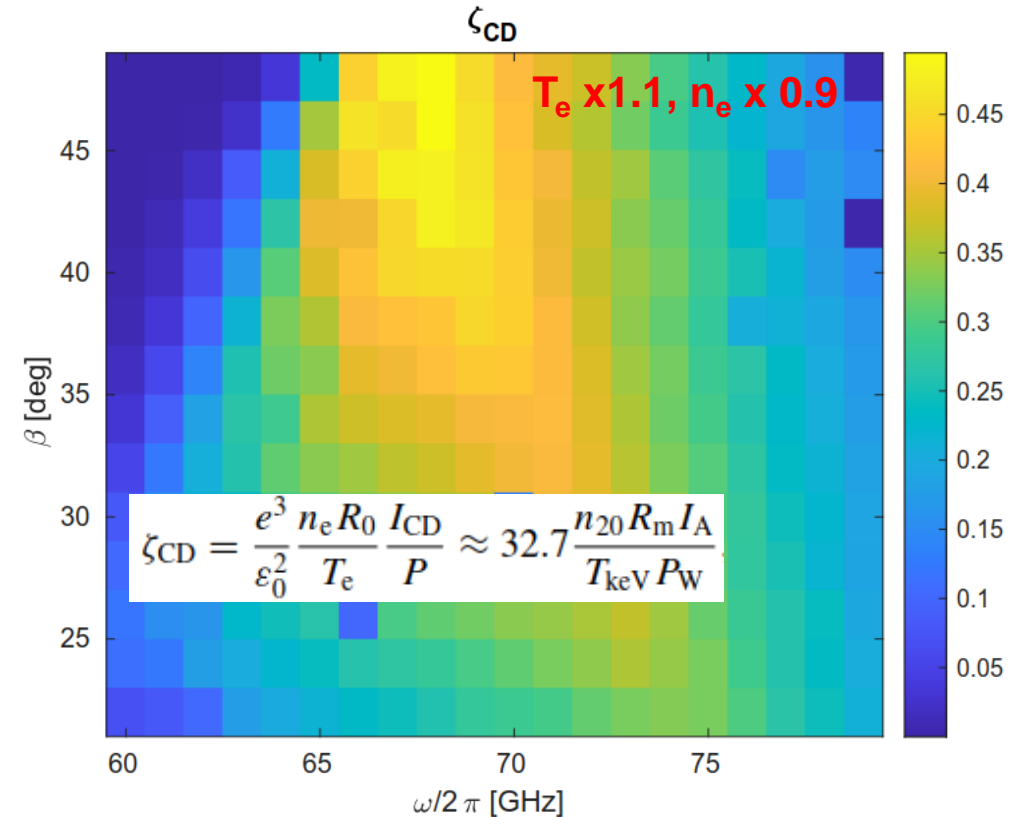
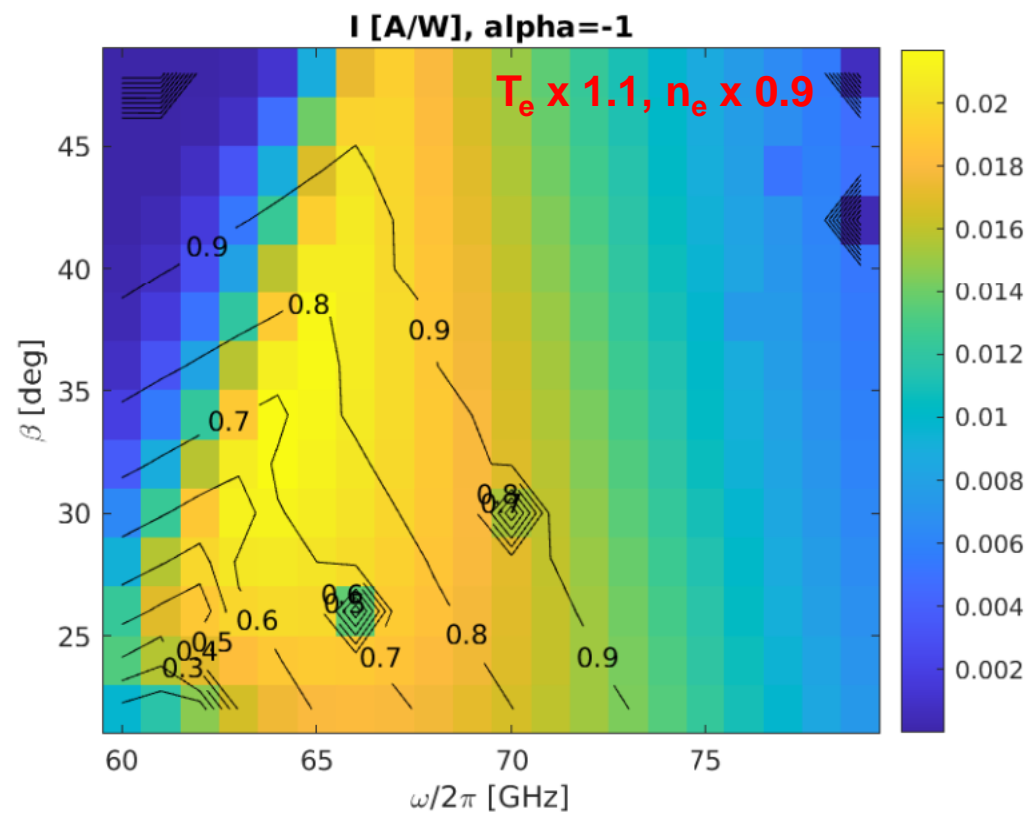

- Potentially more current than O1 scheme for $\rho > 0.7$ (max. 16.5 kA/MW at $\rho = 0.72$)
- Quite high efficiency in the range $\rho \sim 0.8 - 0.9$
- No advantage found for top / HFS injection



* Alternative scheme for the outer core / edge: X1 absorption

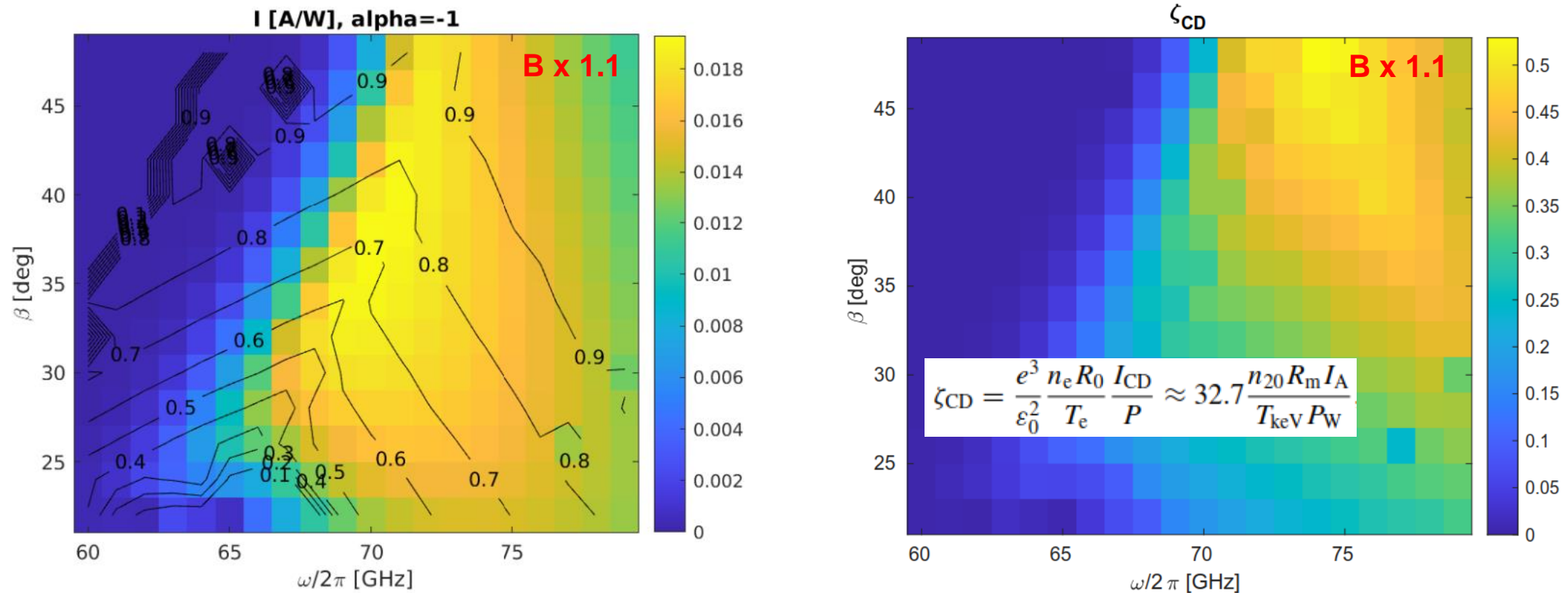

- **X1-scheme from LFS:** shift the resonance outside the plasma (LFS) by lowering the injection frequency, rely on Doppler shift → small operational window
- **Quite high efficiency** in the outer plasma, $\rho \sim 0.8 - 0.9$
- Preliminary studies show no particular advantage from top / HFS launch
- Promising theoretical results for STEP parameters [Figini EC21]



* Alternative scheme for the outer core / edge: X1 absorption

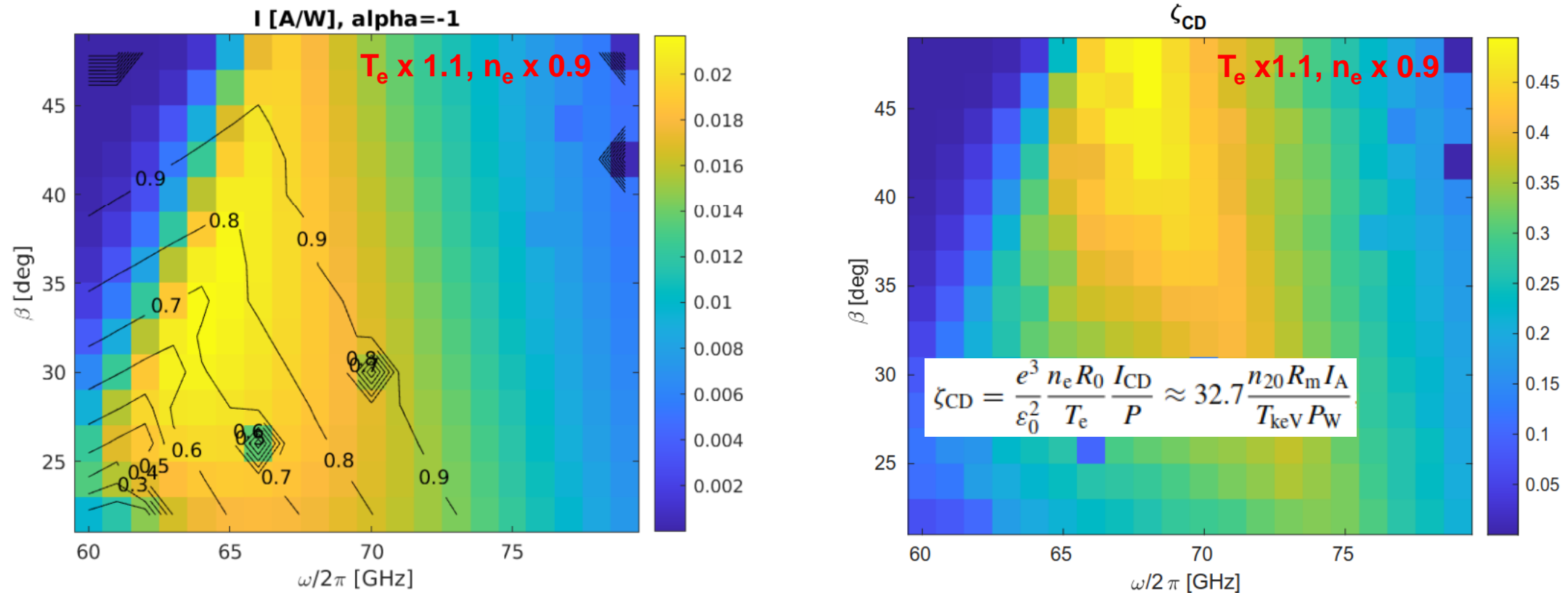

- **X1-scheme from LFS:** shift the resonance outside the plasma (LFS) by lowering the injection frequency, rely on Doppler shift → with operational window
- **Quite high efficiency** in the outer plasma, $\rho \sim 0.8 - 0.9$
- Preliminary studies show no particular advantage from top / HFS launch
- Promising theoretical results for STEP parameters [Figini EC21]

Achievable current with EC waves in Low-aspect-ratio DEMO

Goal of this contribution

- Assess the current drive achievable with electron cyclotron waves in reduced-aspect-ratio DEMO

Main parameters

- $R_0 = 7.5$ m, $a = 2.88$ m ($R/a=2.6$), $B_0 = 4$ T, $Z_{\text{eff}} = 1.5$
- Task: **Evaluate maximum achievable electron cyclotron current drive** (ECCD) for injection from the equatorial plane (conservative); assume max. 50 MW injected power
- Standard O1 scenario (ordinary mode at fundamental harmonic)
- Expected maximum efficiency for central ECCD: ca. 50 kA/MW \rightarrow ca. 2.5 MA in total (plasma current: $I_p = 21$ MA)

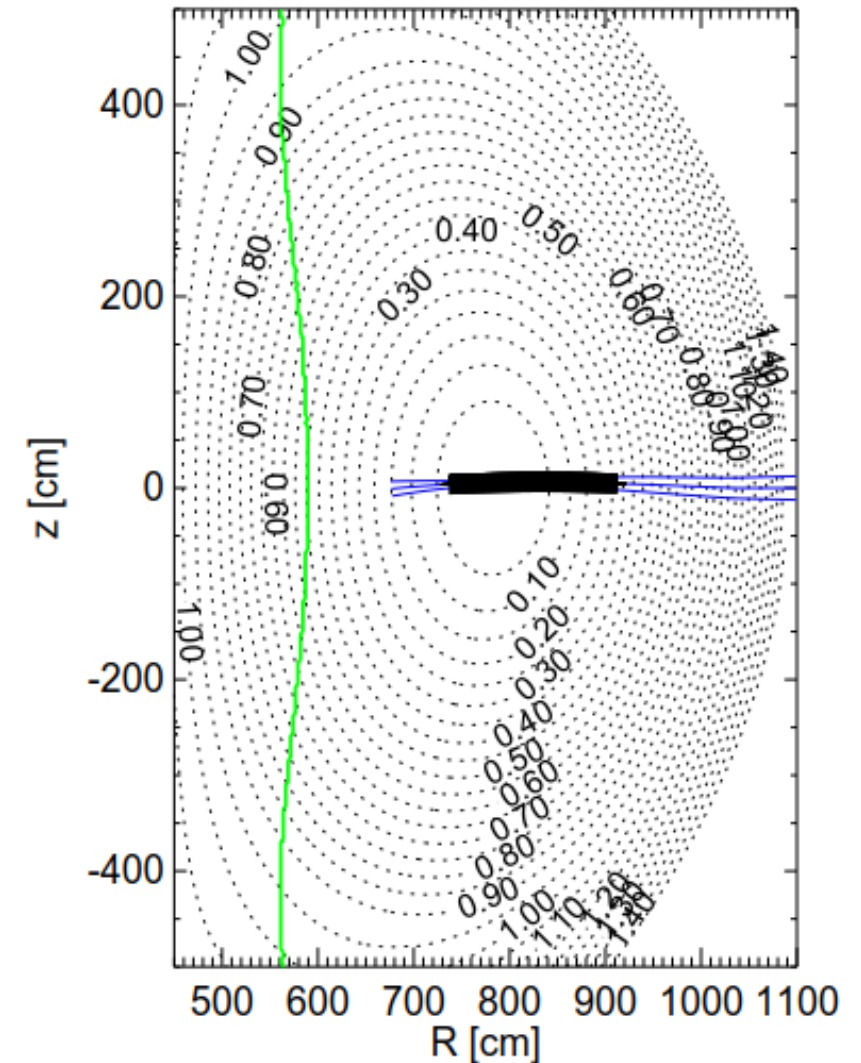

Electron Cyclotron Waves: Heating schemes

- Waves **absorbed around the cyclotron resonance** or a (low-n) harmonic of it
- Typical choices for polarization and frequencies: ordinary mode resonating at the electron cyclotron frequency (O1) and extraordinary mode at twice the cyclotron frequency (X2)

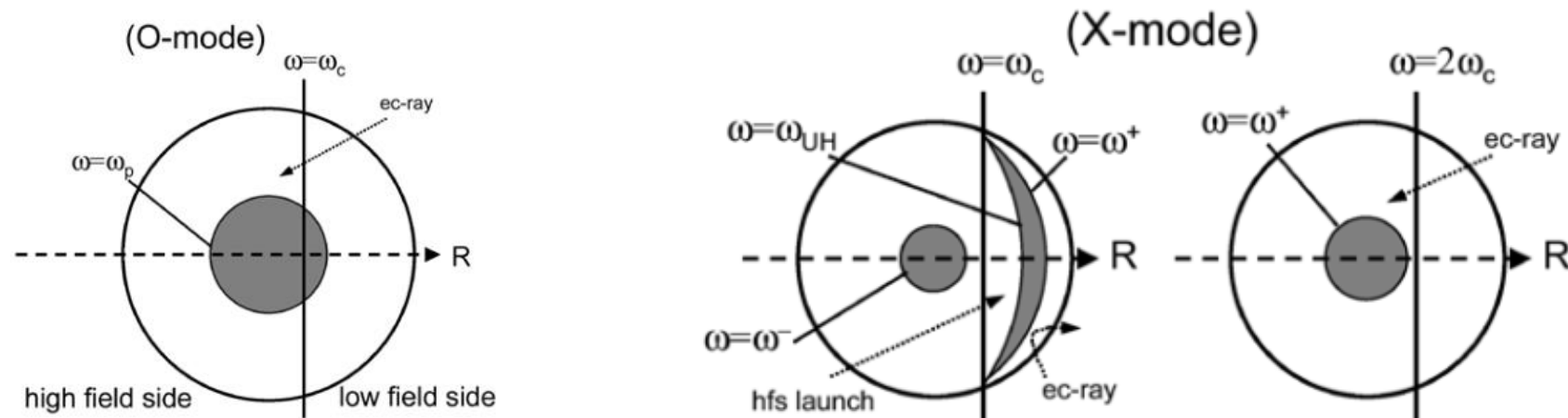

[Westerhof 12]

- X1 access from the low-field side problematic (cut-off on the way to the resonance)
- O1 typical scheme of choice in ITER and DEMO** ← wave frequency well above cut-off conditions for high field, standard-aspect-ratio tokamaks

Alternative scheme for the outer core / edge: X1 absorption

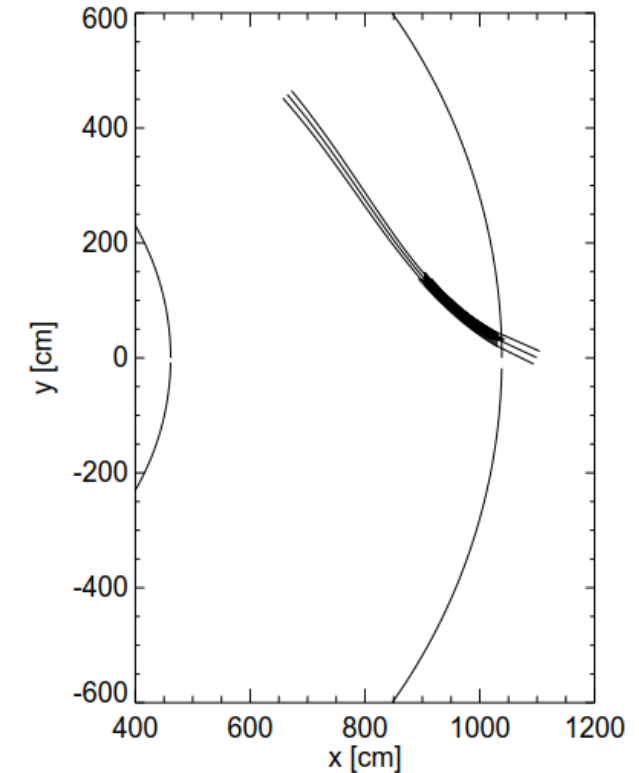
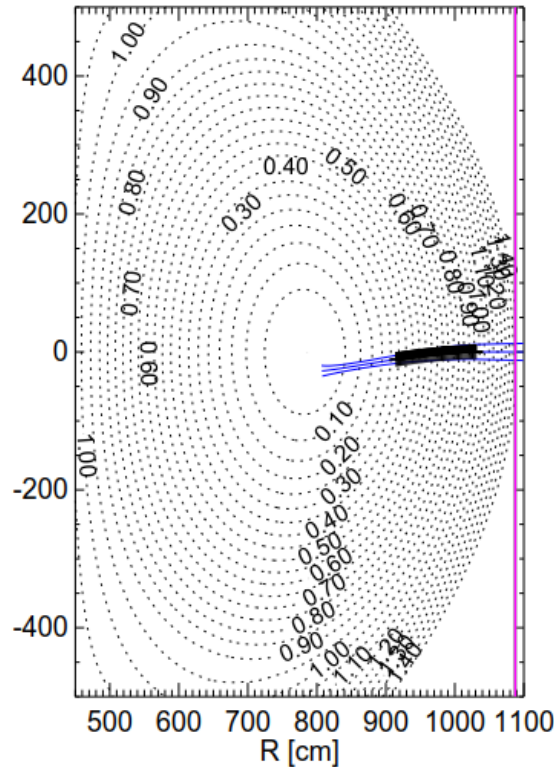
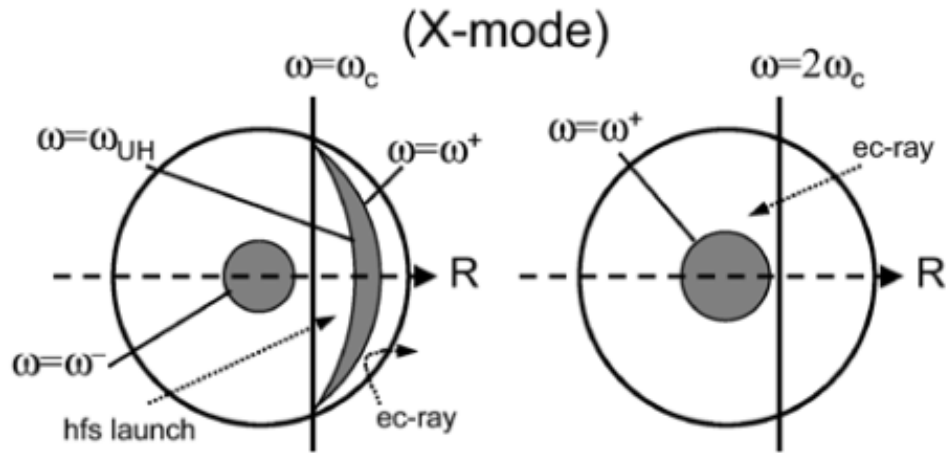

- Fundamental extraordinary mode can have good absorption properties but the cyclotron resonance is usually not accessible from the low-field-side (cutoff before the resonance)
- For large enough toroidal injection angle, the Doppler shift makes the resonance accessible → with limited operational window
- Considered in the recent past e.g for KSTAR [Y-S. Bae], STEP [L. Figini]



* The current drive efficiency $\eta = j/p$

- Absorbed power density: $p = (\Delta\mathcal{E}/\Delta t) n_{res}$
- Express power and current densities in terms of flows in velocity space:

$$\Delta\mathcal{E} = \hat{\mathbf{v}} \cdot \frac{\partial\mathcal{E}}{\partial\mathbf{v}} |\Delta\mathbf{v}|$$

$$\Delta\left(\frac{v_{\parallel}}{\nu}\right) = \hat{\mathbf{v}} \cdot \frac{\partial}{\partial\mathbf{v}} \left(\frac{v_{\parallel}}{\nu}\right) |\Delta\mathbf{v}|$$

- For a cyclotron resonance, $\hat{\mathbf{v}} = \hat{\mathbf{v}}_{\perp}$
- The **current drive efficiency** is independent of the number of resonant electrons [see e.g. Brambilla]

$$\eta = \frac{j}{p} = -\frac{e}{mv_{\perp}} \frac{\partial}{\partial v_{\perp}} \left(\frac{v_{\parallel}}{\nu}\right) = -\frac{3ev_{\parallel}}{mv^2\nu}$$

- Leads to the fundamental scaling $\eta \sim v^2/n_e \sim T_e/n_e$ (last step from assuming that the energy of the resonant electrons scales with the temperature)
- Evaluation of η is more complicated in the presence of relativistic effects and in toroidal geometry, but follows the same idea

* Evaluation of the current drive efficiency

- Quantitative prediction of ECCD efficiency is based on the solution of the steady-state kinetic equation in the presence of collisions and heating [Stix 75, Karney 86]

$$\underbrace{C(f_1)}_{\text{collisions}} - \underbrace{\frac{\partial}{\partial \mathbf{v}} \cdot \mathbf{S}_{\text{rf}}}_{\text{heating}} = 0$$

- (Small) modification of the distribution function as a balance between heating and collisions

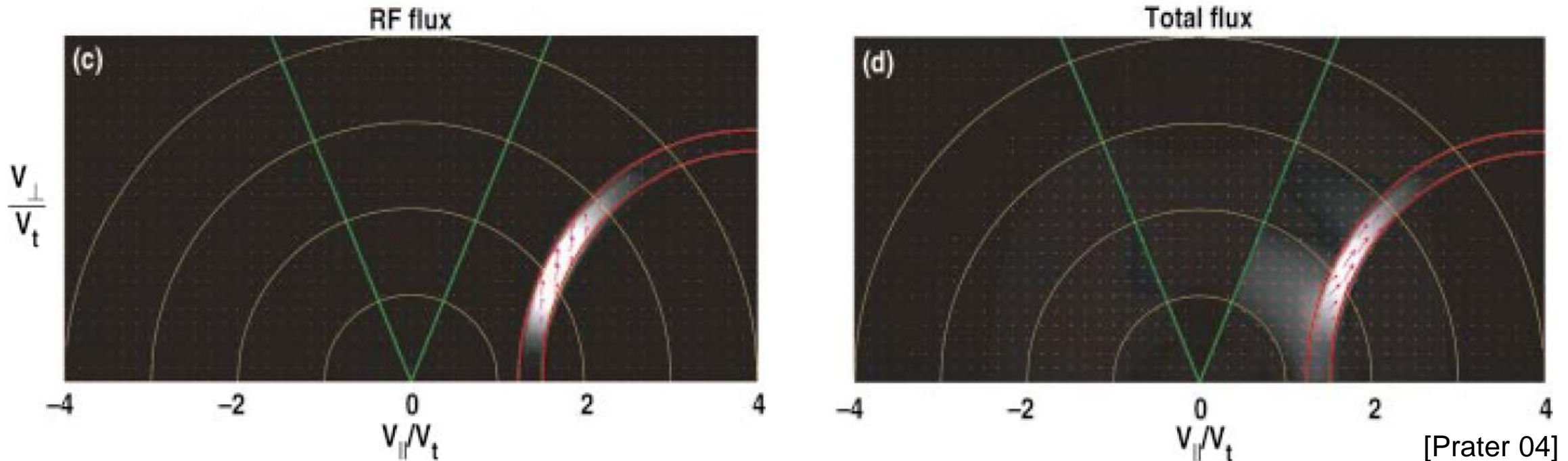

[Prater 04]

* Evaluation of the current drive efficiency

- Quantitative prediction of ECCD efficiency is based on the solution of the steady-state kinetic equation in the presence of collisions and heating [Stix 75, Karney 86]

$$\underbrace{C(f_1)}_{\text{collisions}} - \underbrace{\frac{\partial}{\partial \mathbf{v}} \cdot \mathbf{S}_{\text{rf}}}_{\text{heating}} = 0$$

- (Small) modification of the distribution function as a balance between heating and collisions

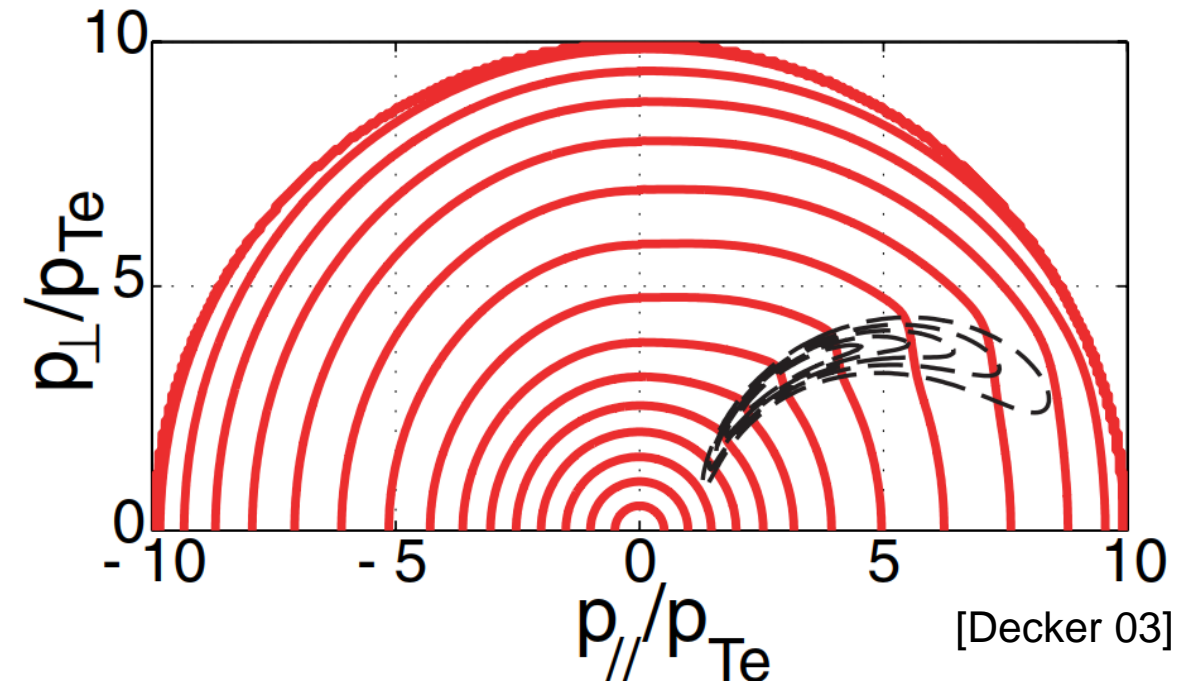
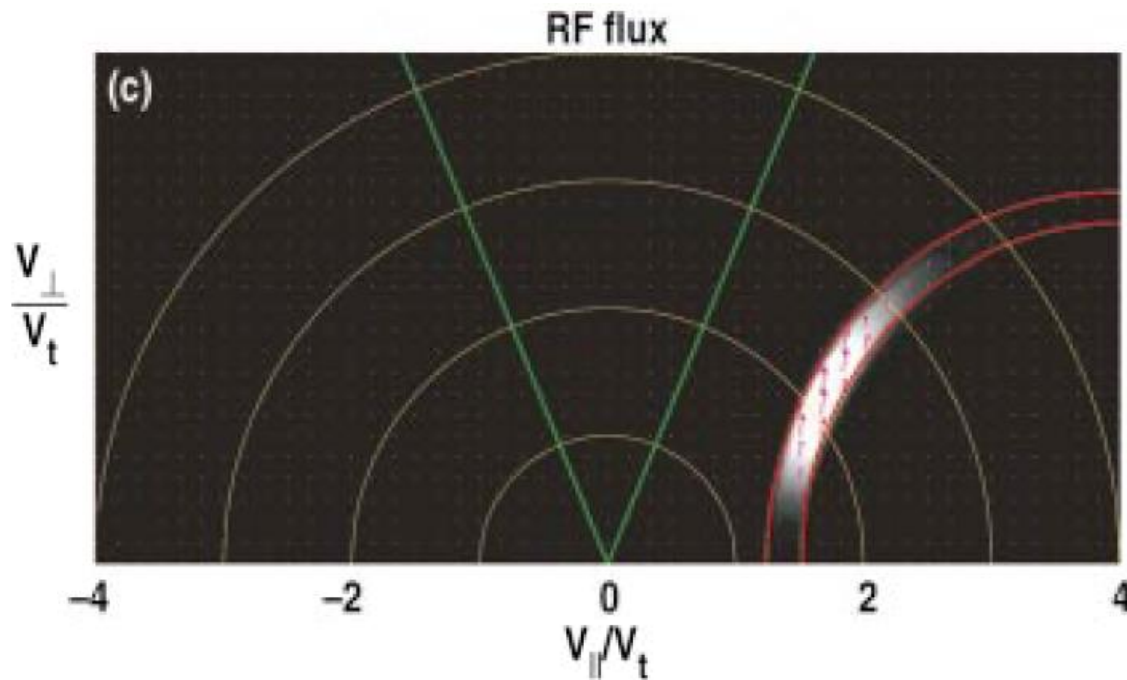



Can we predict the maximum ECCD from global parameters?

- In the optimization strategy shown before, the maximum achievable ECCD efficiency is determined by **scanning the parameter space** (several thousands of runs, each requiring ca 1 s)
- Pro's: accurate evaluation; Con's: **Too time consuming** for a repeated evaluation in a larger loop over tokamak parameters (optimization); **not possible** if equilibrium and profiles are not available (like in systems codes, 0D)
- Two main roads towards faster evaluation of ECCD: (i) simplify the calculation of the current drive efficiency; (ii) choose “representative point” in parameter space for single evaluation of ECCD efficiency



Can we predict the maximum ECCD from global parameters?

- In the optimization strategy shown before, the maximum achievable ECCD efficiency is determined by **scanning the parameter space** (several thousands of runs, each requiring ca 1 s)
- Pro's: accurate evaluation; Con's: **Too time consuming** for a repeated evaluation in a larger loop over tokamak parameters (optimization); **not possible** if equilibrium and profiles are not available (like in systems codes, 0D)
- Two main roads towards faster evaluation of ECCD: (i) simplify the calculation of the current drive efficiency; (ii) **choose "representative point" in parameter space for single evaluation of ECCD efficiency**
- Fundamental idea: the **maximum ECCD is a trade-off** between two competing effects
 - Need for high-energy (low-collisionality) electrons → **favours resonance on the tail** of the distribution
 - Need for sufficiently high absorption → **favours resonance on the bulk**
- Strategy implemented in the module HARE coupled to the PROCESS systems code → typical runtime 0.1 ms [Poli 18]