



MAX-PLANCK-GESELLSCHAFT  
FRITZ-HABER-INSTITUT



# Further development of Open Source products: EPICS in the Max Planck Society

Patrick Oppermann



# Motivation

- Scientists need digital data acquisition and data output
- Standard solutions are based on PCs which are used for multiple tasks and are then equipped with data acquisition cards
- Manufacturers of data acquisition cards provide software/drivers for common data processing software (LabView)
- For these systems there is normally no possibility of scaling



# Project Goals

- Establish EPICS in the Max Planck Society
- Increase the visibility of EPICS within the MPG
- Reduce the hurdle to using open source software and hardware
- Improve the documentation of EPICS and create training documents
- Set up of Demo hardware



# Software and Hardware

- EPICS based data acquisition and storage
  - Cloud based storage
- Time and Frequency readout
- Stand-alone systems
- Open Source Hardware
- Adapting the system for the user
- (Possibility to enable fast data processing)

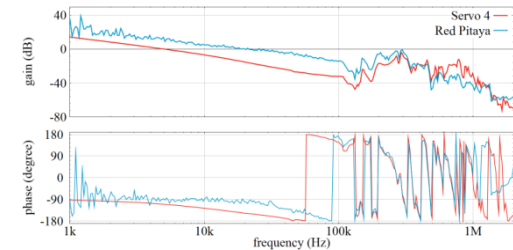
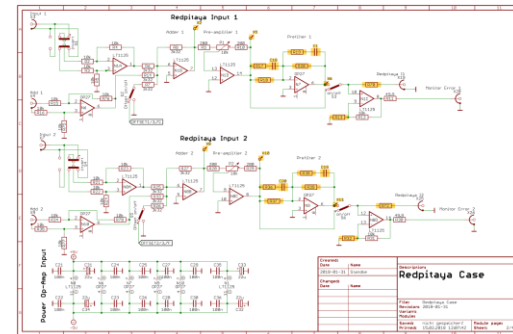
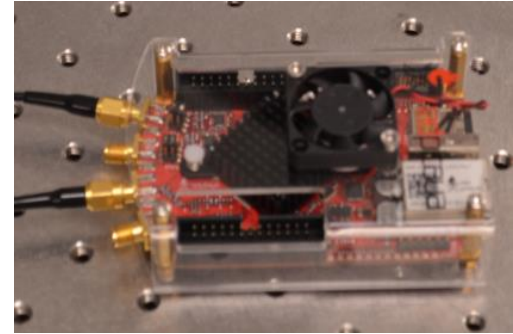

Credits: Mark Standke



# Documentation and Demo system

- Instructions in German and English language
- Simple user examples and modules for basic tasks
  
- Finished system for table top experiments
- Transportable "experiment" with simple stabilization (for example laser power)

