

Motivation

In modern accelerator applications, stringent requirements are placed on the noise performance of digital converters. The noise from the digital converter will become part of the field noise seen by the beam, thus necessitating a low-noise, low-crosstalk digitizer. In response to this demand, this paper presents the design of a digital converter circuit board with 8 ADC channels and 2 DAC channels, which has been subjected to testing. The test results indicate that the circuit board possesses low noise and low crosstalk characteristics, rendering it suitable for reading accelerator signals.

Hardware Design

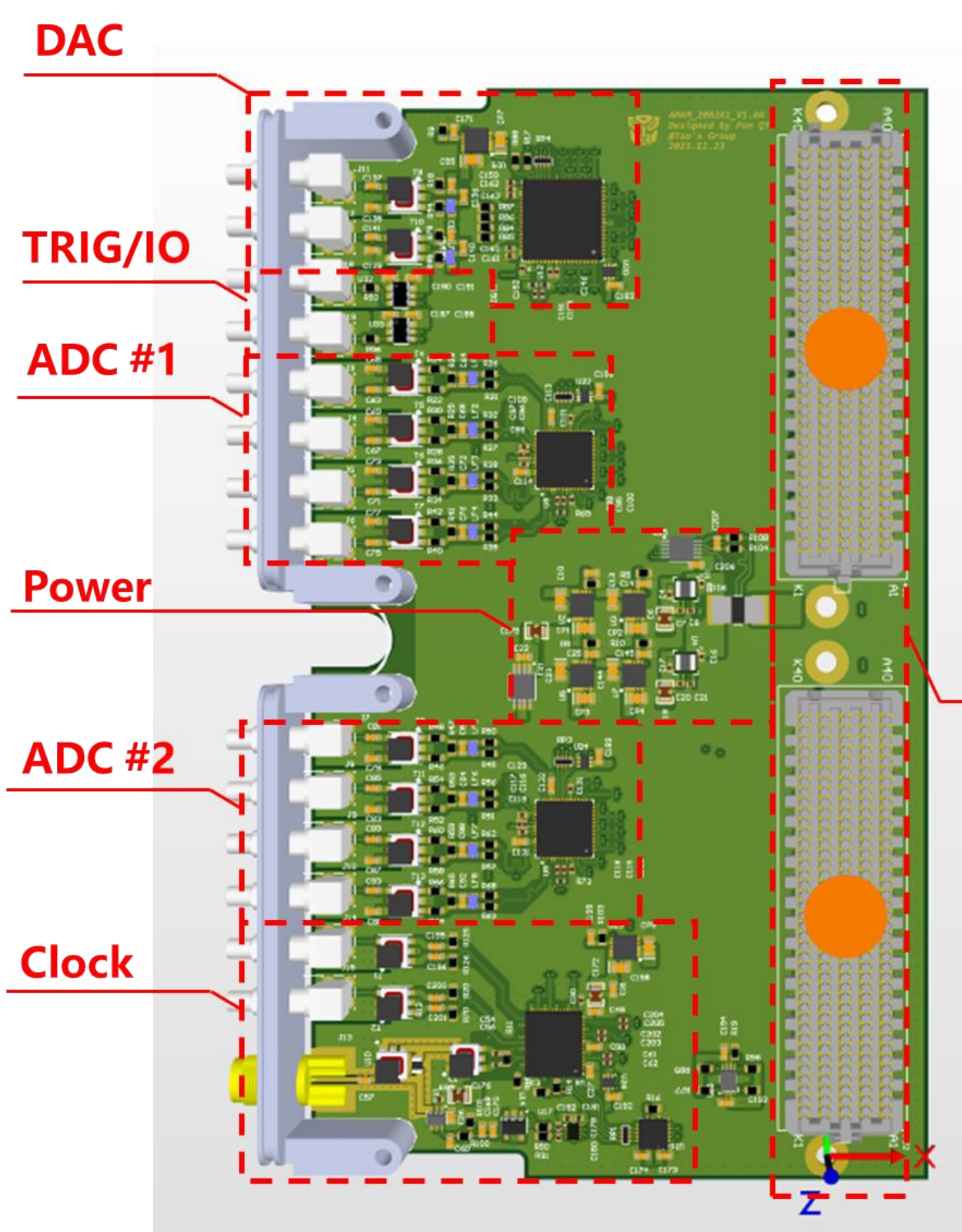

Fig.1. Main functional components

The main functional components include two quad 125MSPS 16bit ADCs, one dual 500MSPS 16bit DAC, a clock distributor, trigger function circuit, FMC connectors.

- ADC: AD9653
- DAC: AD9783
- Clock Distributor: LTC6953

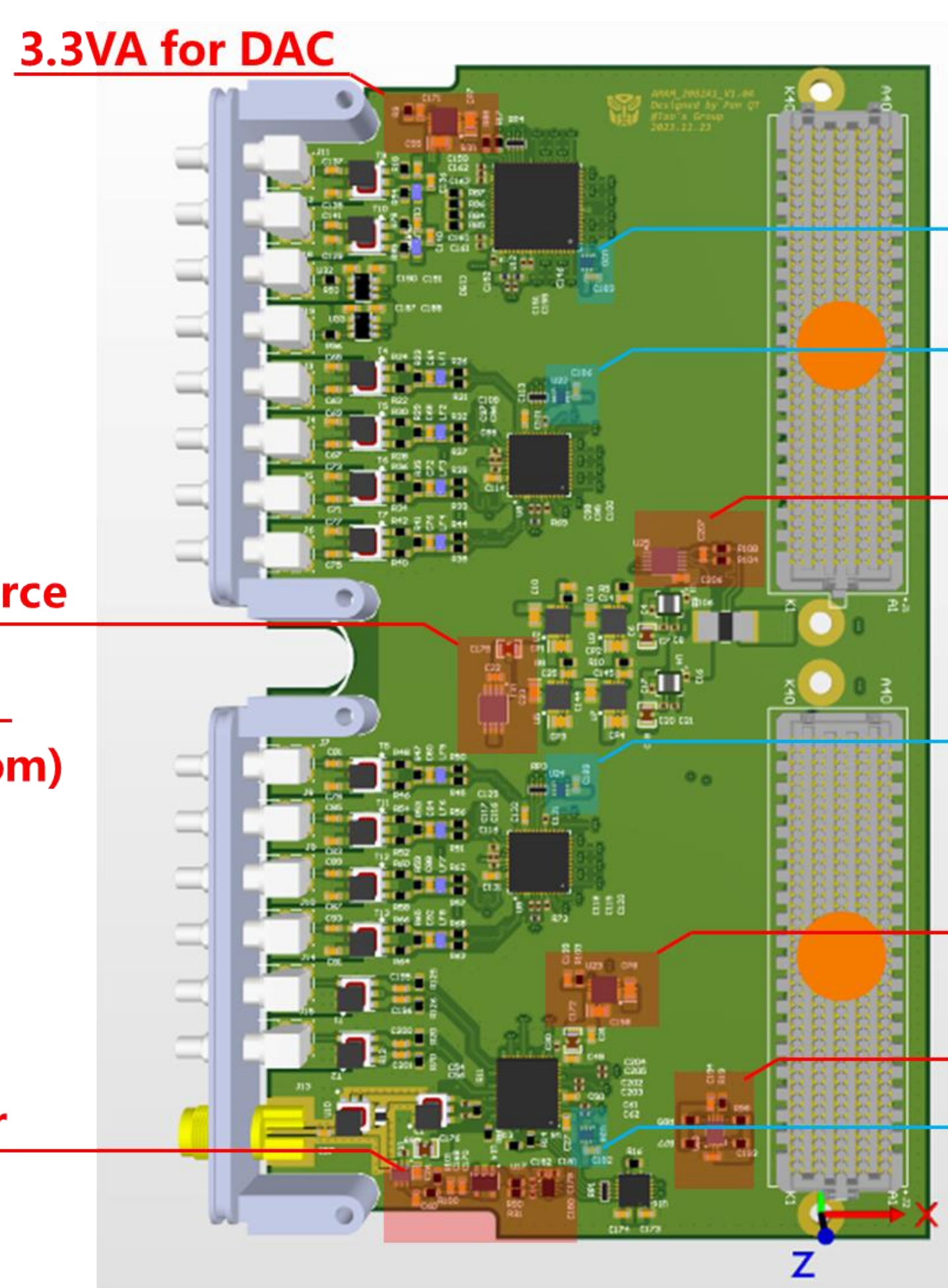

Fig.2. Other functional components

Other features include current monitoring, temperature monitoring, RMS detector, etc. These functions can be interfaced with FMCs via the IIC protocol, which allows the use of FPGAs or MCUs to interact with these chips. This design uses an external 1.25V reference voltage.

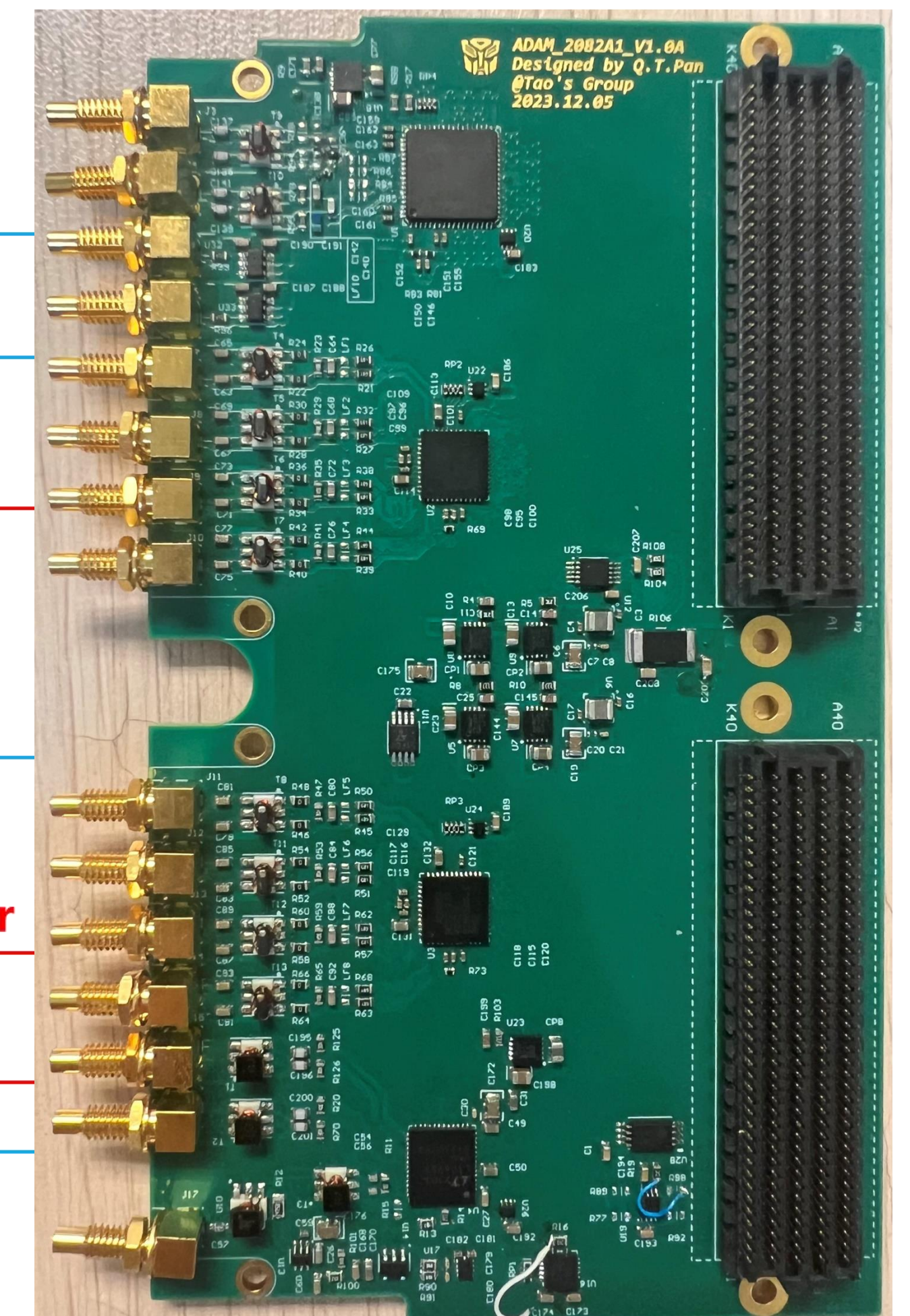

Fig.3. Actual circuit board photograph

Experiment

The experiment uses the SMA100B signal source to generate a sine wave signal and 500MHz clock. The 500MHz clock can be divided by the LTC6953 to provide a 500MHz clock for the AD9783 and a 125MHz clock for the AD9653.

The FPGA used for data readout is XCKU060-FFVA1156-2.

- The logic block diagram for the AD9653 data readout is shown below. The method is similar for different channels.
- The DAC AD9783 analog output logic block diagram is shown below.
- The parameters of the clock distributor LTC6953 can be made via SPI.
- Current monitoring, temperature monitoring, and RMS detector values can be read via the IIC.

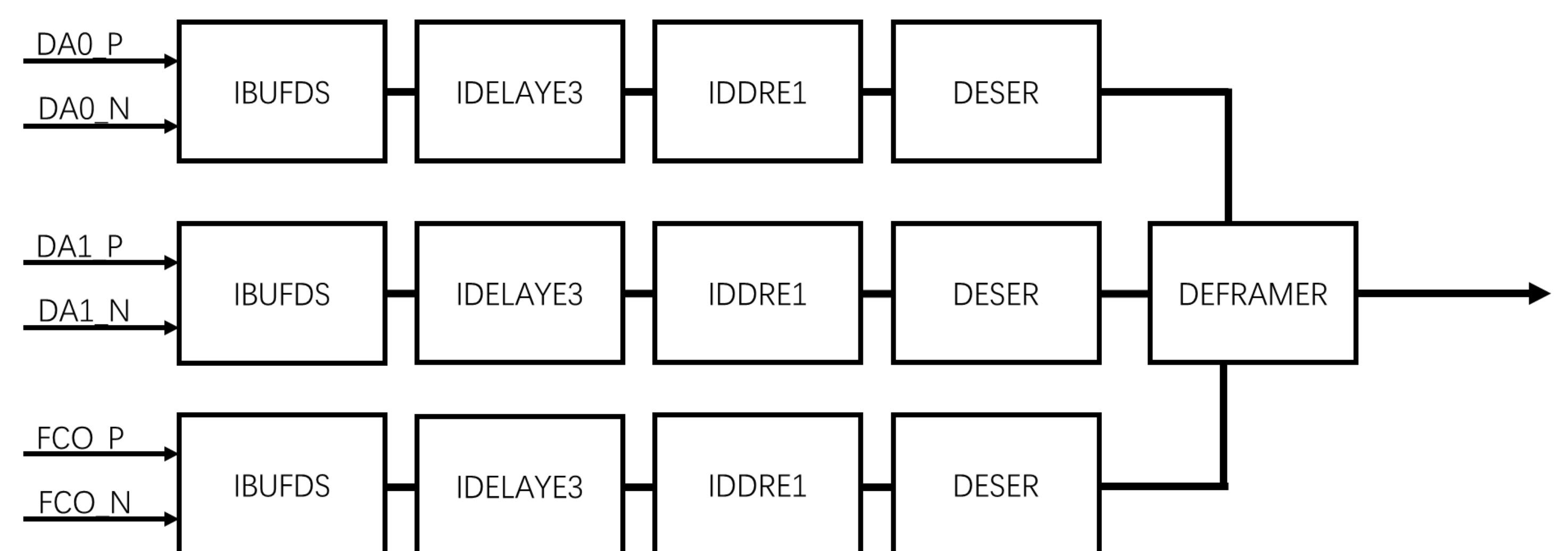

Fig.4. AD9653 Readout Logic Block Diagram

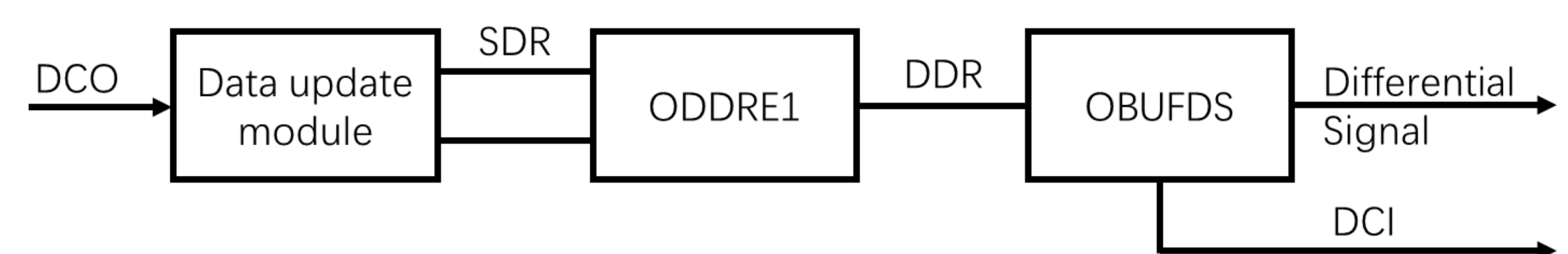

Fig.5. Actual circuit board photograph

Result

The ADC's ENOB can be as high as 12.96 when using an external 1.25V reference voltage. Part of the waveform and the SNR analysis are shown in the right figure. The experimental conditions for the figure on the right are an ADC sampling rate of 125 MHz and a sine wave signal source frequency of 10 MHz.

After testing, the supply voltage of this circuit is 12V, the current is about 0.45A, and the power is about 5.4W.

The temperatures in the vicinity of the main devices under full power operation conditions are as follows:

- LTC6953(500MHz input; 500MHz output*1 and 125MHz output*2) : ~ 55°C
- AD9653#1 : ~ 50°C
- AD9653#2 : ~ 45°C
- AD9783 : ~ 40°C

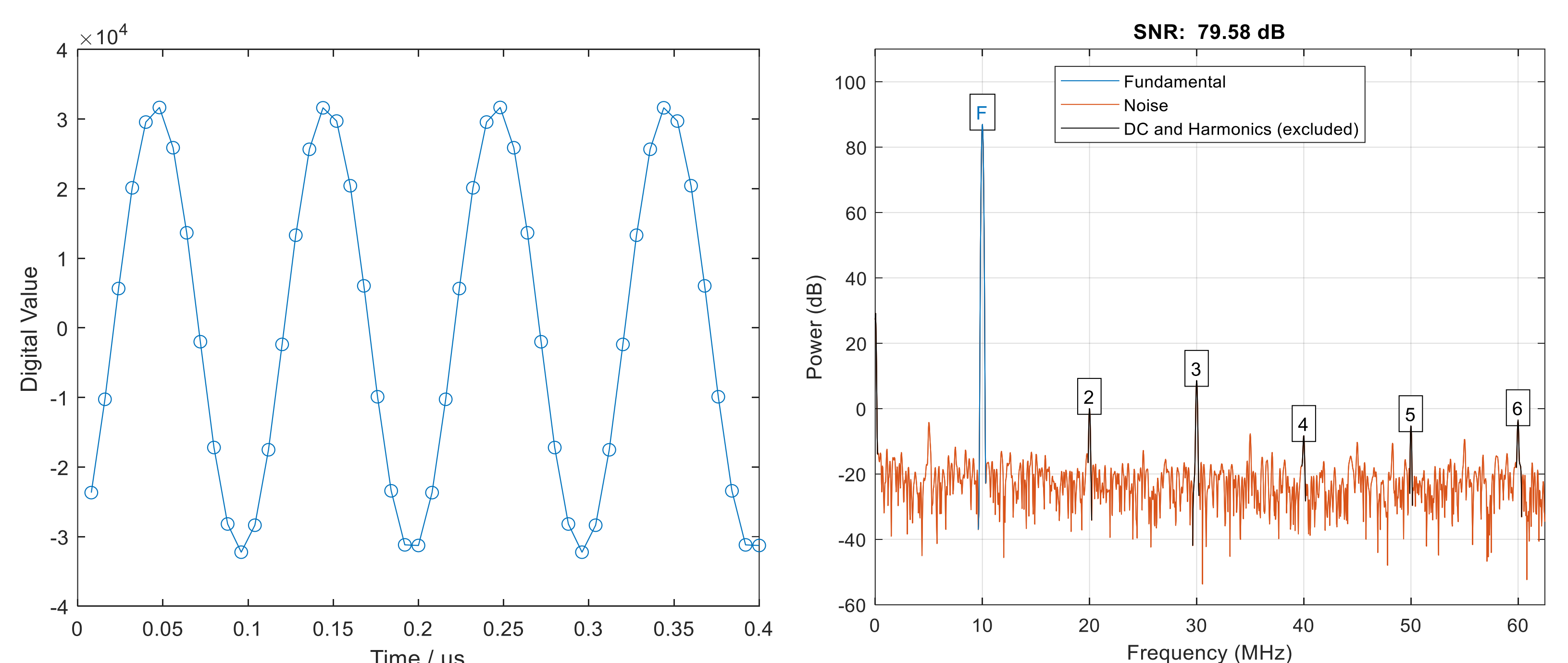

Fig.6. Waveform and SNR analysis