

HEP detectors overview and example

Christian Bohm
Stockholm University

Outline

Physics Background

LHC and its detectors

ATLAS and its subdetectors

Trigger and Data Acquisition

Synchronization

Future

Introduction

We study new physics by **colliding high energy particles**

New particles can be produced in these collisions if the energy is sufficiently high.

If we collide protons the probability (cross section) for this is small.

You need many collisions to increase the probability – need **high luminosity** and **many repetitions**

The protons contains three quarks

Not only must the protons collide head-on but also their constituents.

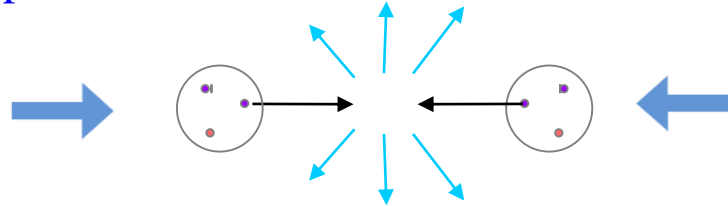

After doing this for some time, we look for unusual interesting events.

And not only one, we want **many** to believe the results

Thus,

- **We must collide a large number of protons each time – use high luminosity proton beams**
- **We must repeat collisions many times – use high collision rates**

Why we need to record many events

To determine if our N new observed events constitute a discovery we must determine if the same data could be produced by combinations of well-known events. The probability for is the background B .

For N to be a discovery N must be significantly larger than B

For example if N is 80 and B is 64 then $\sigma(B)$ is 8 (assume Poisson distribution $\sigma^2=N$)

N is 2σ above i.e. 2% probability that N is just random noise

If we measure twice as long N will be 320, B is 256 and $\sigma(B)$ is 16 i.e. about 4σ above (0.004% that it is random noise). Much smaller probability that N is due to random noise but not enough.

5σ (0.00002% it is random noise) is required for discovery.

The significance of N can grow after more measurements, but the significance could also decrease or even disappear.

There are many 3σ that have disappeared, but a 5σ must have been a 3σ at some point.

Normal distribution
Almost the same
as Poisson if $N > 50$

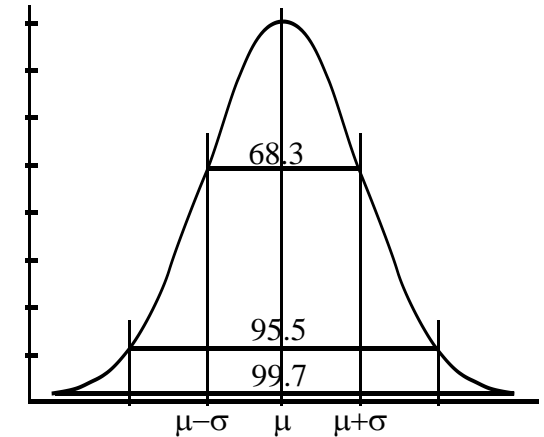

Beyond the Standard Model

We have a theory, the **Standard Model**, to explain much of the particle physics we have observed, but not all. The task is to explore **Beyond Standard Model (BSM)** physics

One way is to find new observational results that cannot be explained by the Standard Model
Better precision (higher luminosity and longer time) increases the probability for deviations

Another way is to propose theories that agrees with existing experimental results but also predicts new results that can be tested with experiments

Some potential BSM theories predict super symmetric partners to all normal particles – **none of which have been seen so far**

To progress we need to know where the Standard Model fails

We need more data and/or higher energies

Detectable Standard Model particles

The **Standard Model**, explains most of the particle physics we have observed (but not all).

The most basic constituents are:

Leptons, quarks and bosons

These can be created in collisions in high energy physics experiments at accelerators, but the short lived particles decay before they reach the detector. They can only be deduced by their decay products.

We can detect **electrons**, (positive) **muons** and their anti particles (**positrons** and negative muons)

The only boson we can detect is the **photon**.

We can detect composite particles (charged and uncharged) formed by quarks, called **hadrons** but have problems identifying them.

The hadrons can be **mesons** and **baryons** such as **protons** and **neutrons**

Jets

In the standard model there are 6 types of quarks and 6 types of antiquarks.

Free quarks are never seen. You only see combinations of them, hadrons.
They can combine into baryons (3 quarks) or mesons (a quark-antiquark pair).

One way to **illustrate** the quark behavior is to see them as **string ends**.

A mesons will then be modelled as:  and a baryon (e.g. a proton) as:  or 

If you stretch a meson, i.e. trying to move the quark and antiquark away from each other, the string breaks.

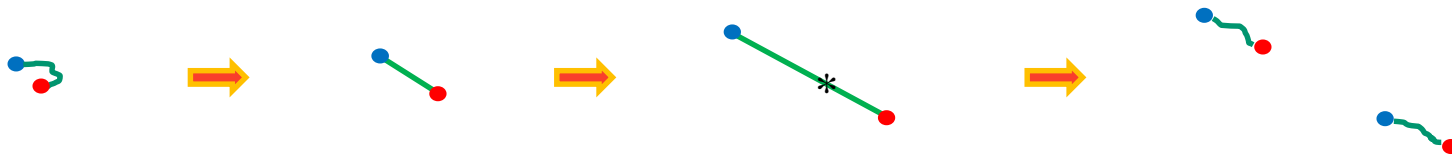

Forming two strings with two new string ends, a new quark-antiquark pair, and thus two mesons

Jets

If the quarks in a meson separate with a high kinetic energy there will be multiple string ruptures a **jet** of hadrons

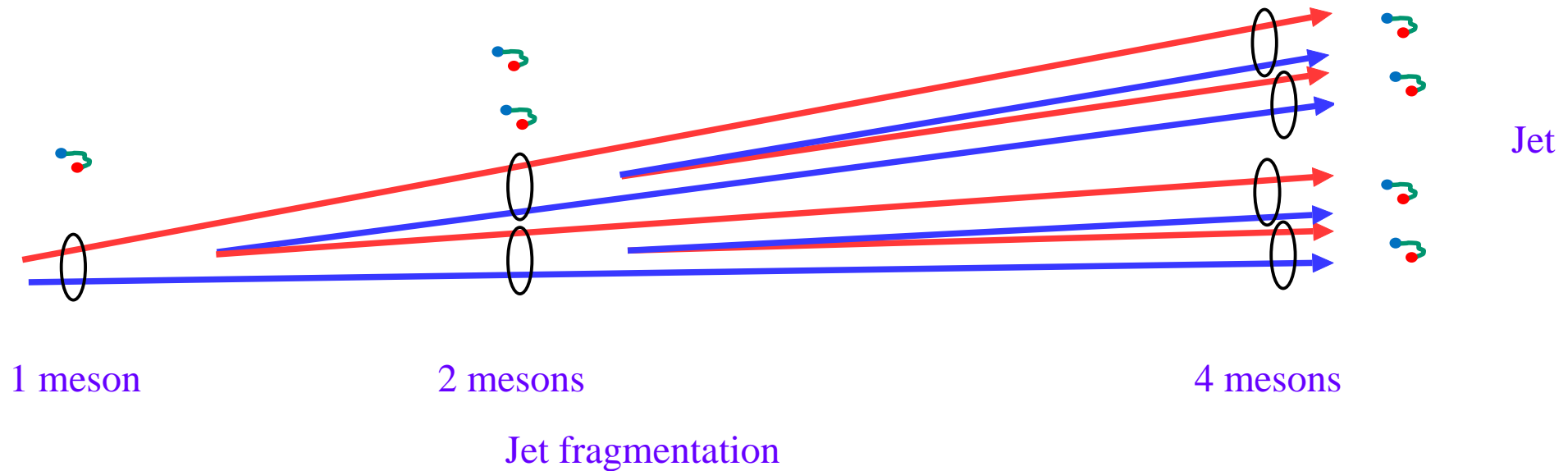

Whenever a quark tries to escape a jet is formed

Short lived particles

You have to infer the existence of short lived ($< 10^{-10}$ sec) particles by recording the disintegration products

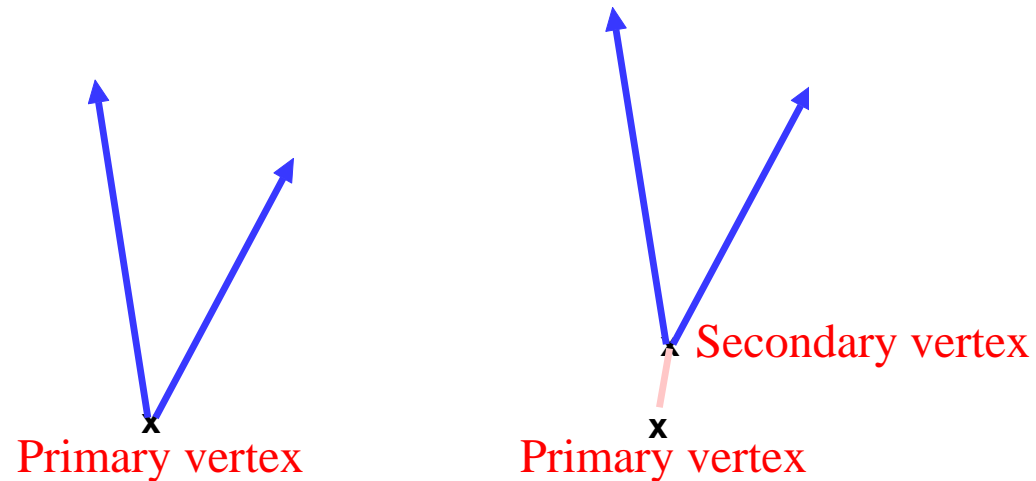

But this opens for mistakes:

If $A \rightarrow B, C$ and you record B and C it is not **certain** they came from the same A. They might have come from **different** processes

Need to know the direction with high precision

Then you can identify if it is a secondary vertex

Missing Transverse Momenta (Energy)

The center of gravity of all particles created in an explosion stay at the collision center

The vectorial sum of all momenta in the COG system is 0

Same thing applies to the transverse projection

If one particle is not detected there will be a missing transverse momenta

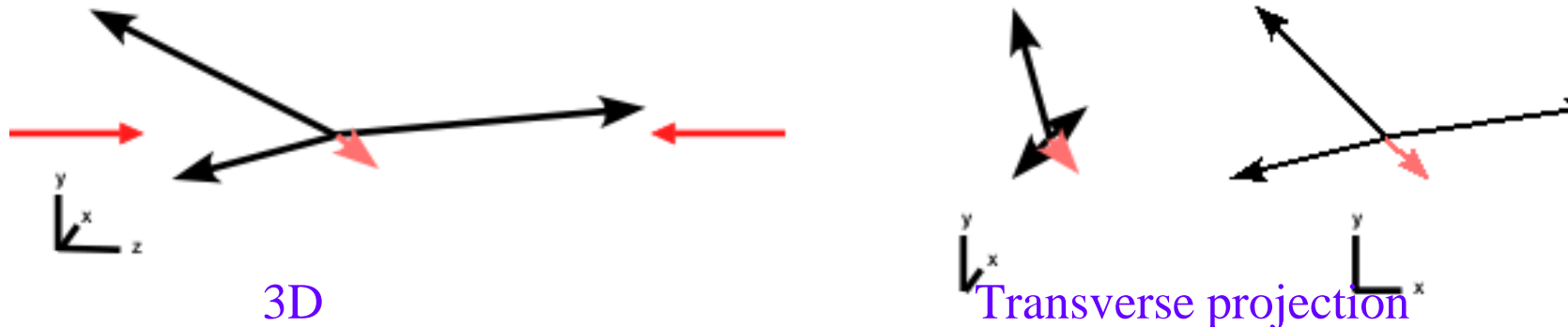

Missing transverse momenta can be due to:

- Particles that cannot be detected (e.g. neutrinos) or failing detector elements
- The detector should be hermetic

Colliders

One solution to get high luminosity and high repetition rate is to circulate the particles (e.g. protons) in two ring accelerators that cross in regions where the particles can collide

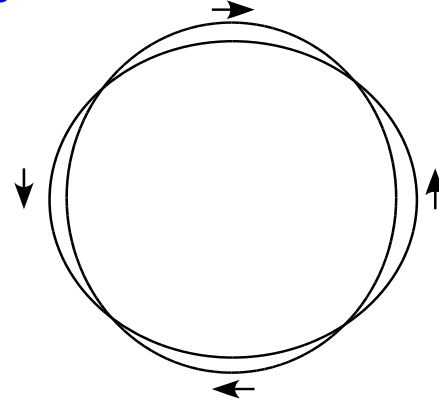

Most protons will pass through and continue to recirculate, but some would collide (along with collisions with rest gas)
Eventually all protons will be lost, but before that they will pass each other many times

A better solution is to group the protons in bunches and let the bunches collide

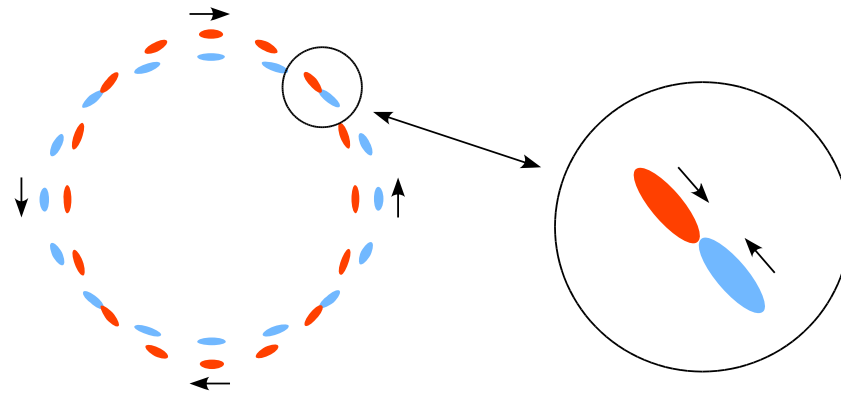

Detector and Subdetectors

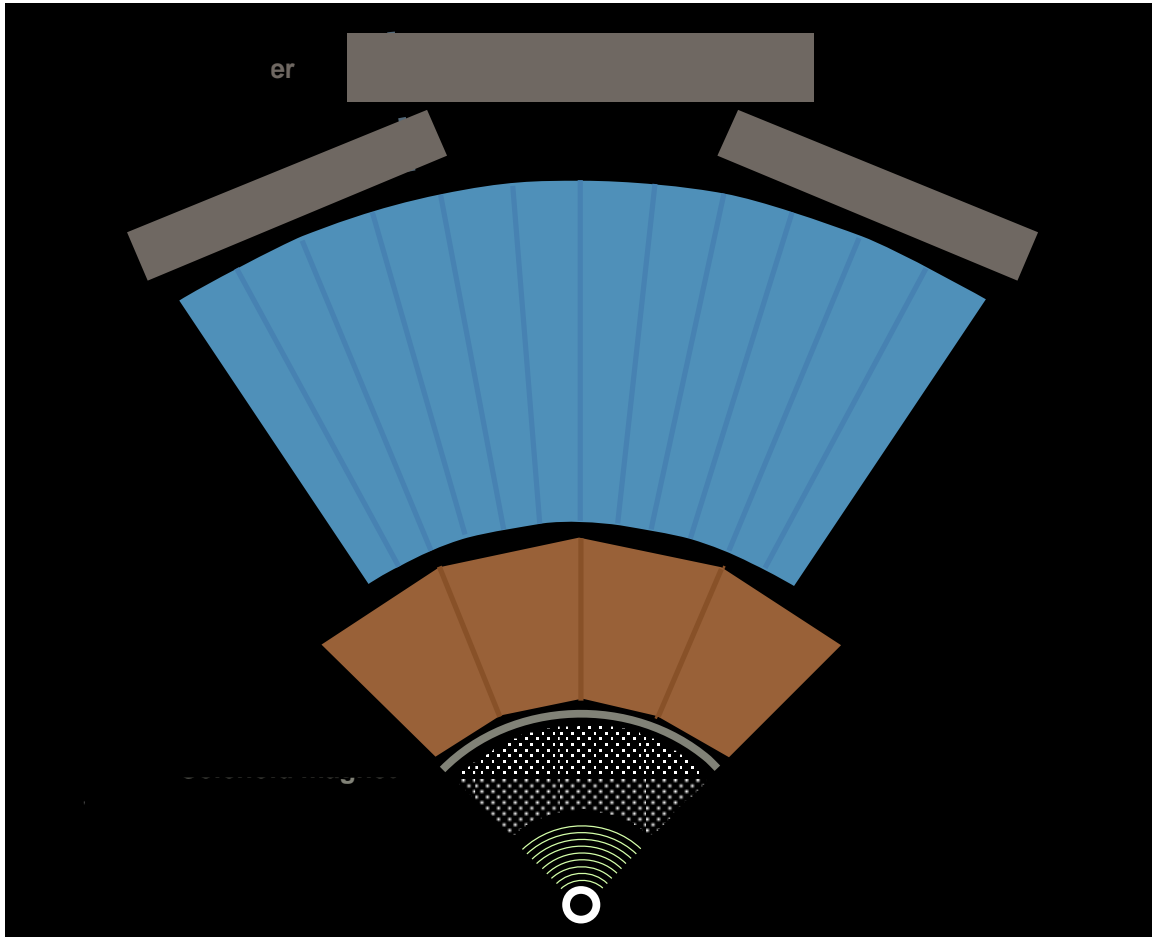

All short-lived particles decay before entering the detector itself

Remaining particles: e^- , e^+ , γ , hadrons (p, n..., jets), μ^+ , μ^- , ν , ?

Onion-like with multiple subdetector and magnet shells:

Inner detector (tracker) with Pixel, SCT and TRT

to find charged particle tracks

Solenoid magnets to deduce charge and momentum

Electromagnetic calorimeter to measure e/m tracks and energy

Hadron calorimeter to measure hadron and jet tracks and energy

Muon detector to detect muon tracks and momentum

Identifying the collision event

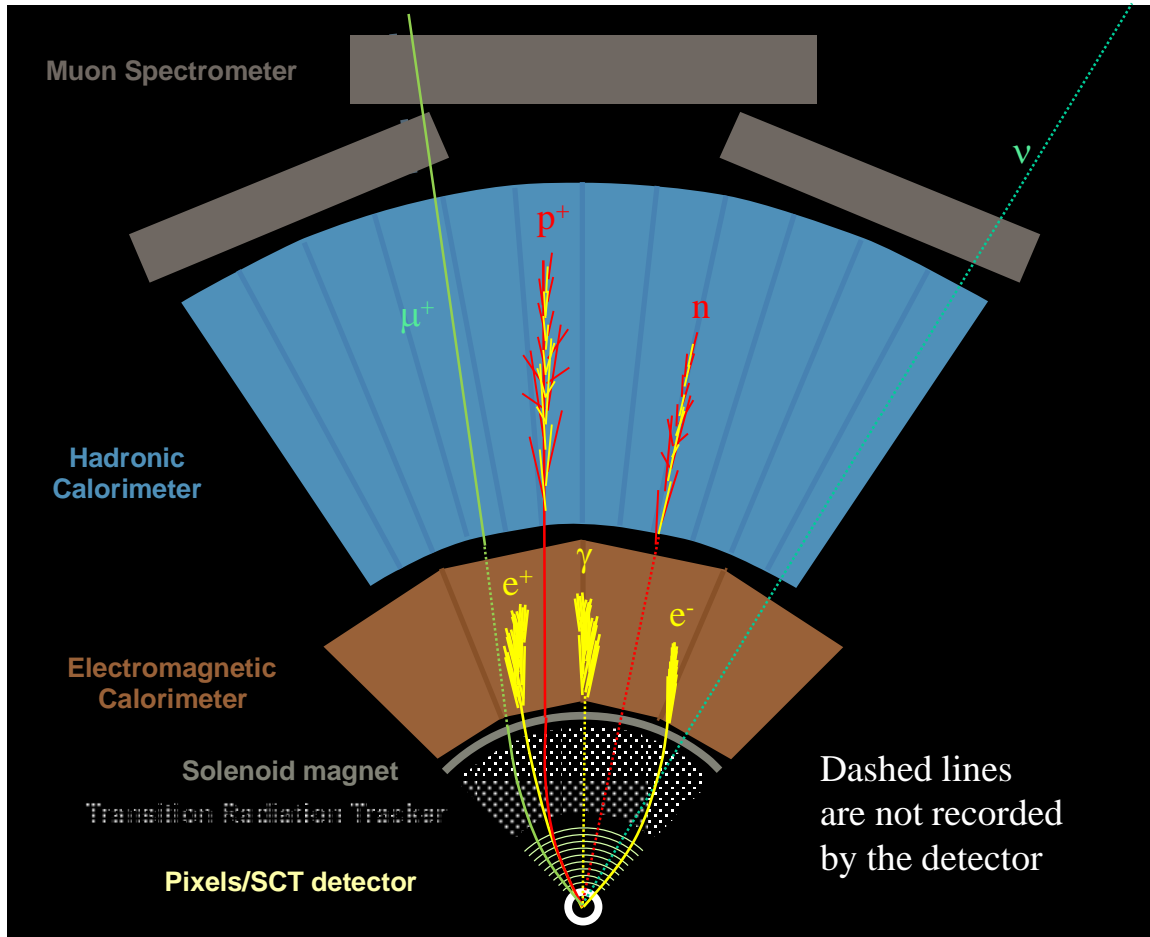

An electron (e^-) leaves a track in the inner detector with negative (here counter clockwise) curvature and showers and is absorbed in the electromagnetic calorimeter

An higher energy positron (e^+) leaves a positive smaller curvature

A photon (γ) leaves no track in the inner detector

A positive muon (μ^+) leaves a positive curvature track in the inner detector, a weak track in the hadron calorimeter and a signal in the muon spectrometer

A proton (p) leaves a positive curvature track in the inner detector, a track in the e/m calorimeter and a track in the hadron calorimeter

A neutron (n) leaves no track in the inner detector, a track in the e/m calorimeter and a track in the hadron calorimeter

A neutrino (ν) does not leave any tracks at all

Identifying the collision event

Group particles from the same interaction point
 point – could be outside beam pipe

Deduce source particle:

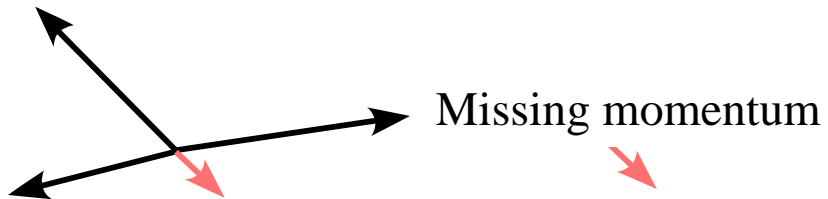
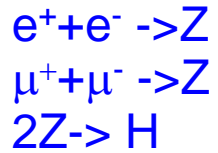

Transverse vectorial momentum sum should be
 If not, something is missing – a neutrino, or
 something more exciting

Broken parts must be
 corrected for

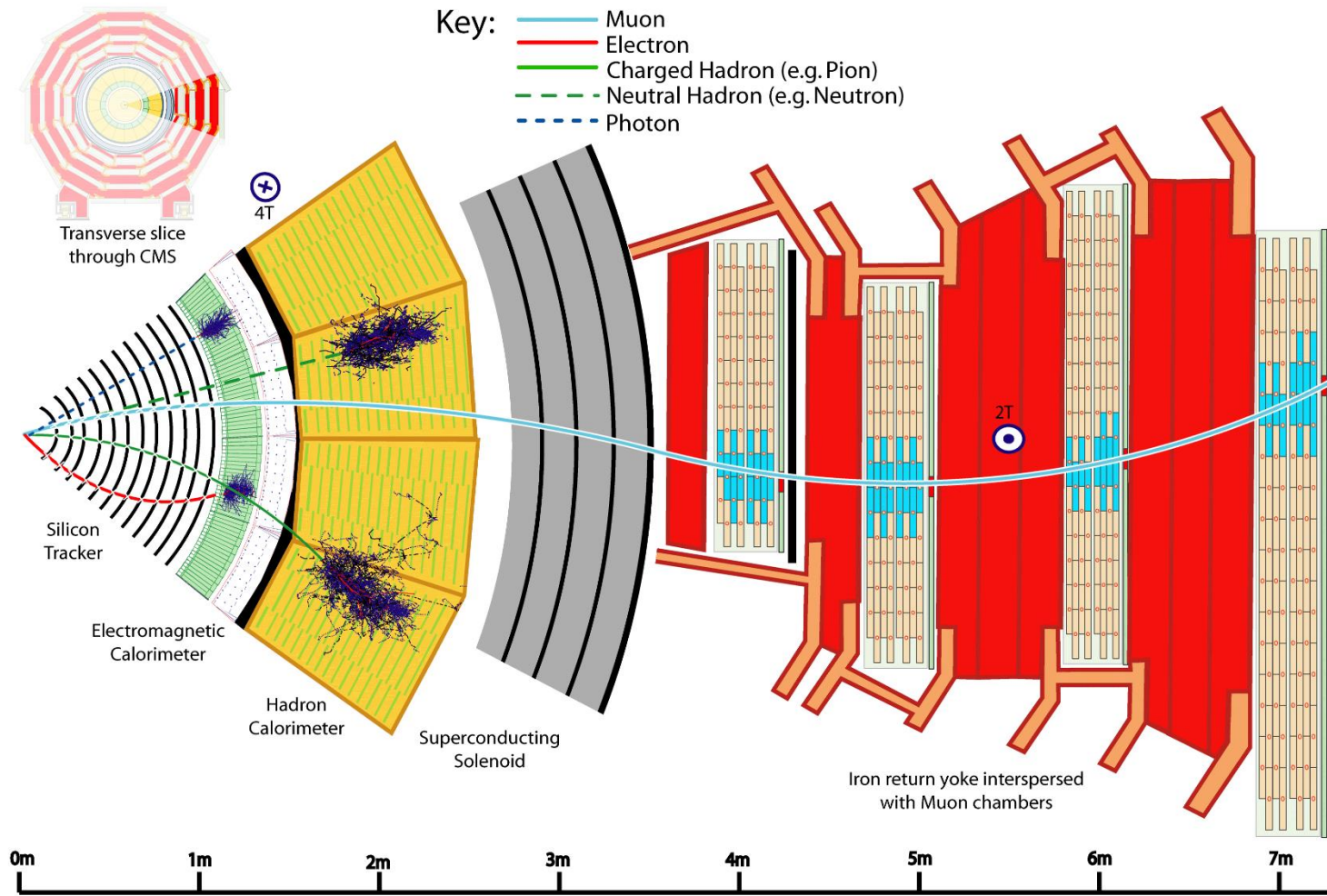

The Large Hadron Collider

27km circumference double ring collider

13 TeV (6.5+6.5) – 0.999999991 times c , i.e. 3m/s less than c

4 interaction points with detectors – ATLAS, CMS, LHC-B and ALICE

$1.5 \cdot 10^{34}$ protons/cm²/sec focused into 16 μ beams that collide

1600 superconducting magnets (up to 9T) to bend and focus the beams

Bunches with about 10^{11} protons collide every 25 ns

The total beam energy is 562 MJ – melts 2 ton copper

Start of operations 2010 (2008)



CROSS SECTION OF LHC DIPOLE

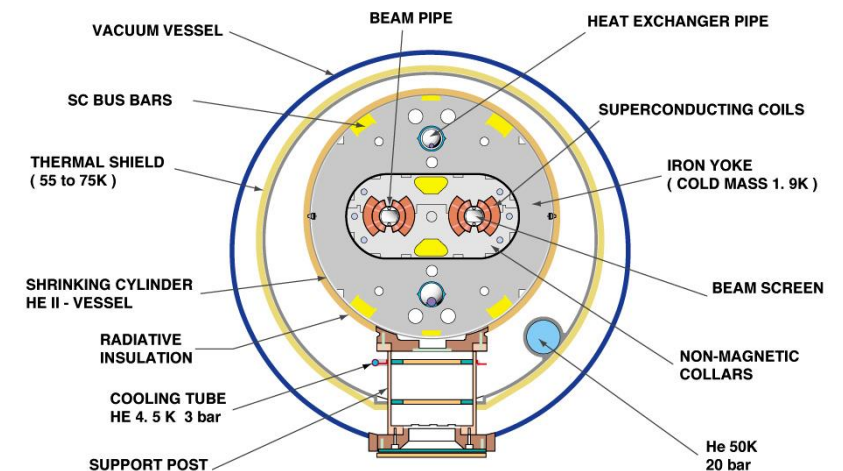

Separate data from different Bunch crossings

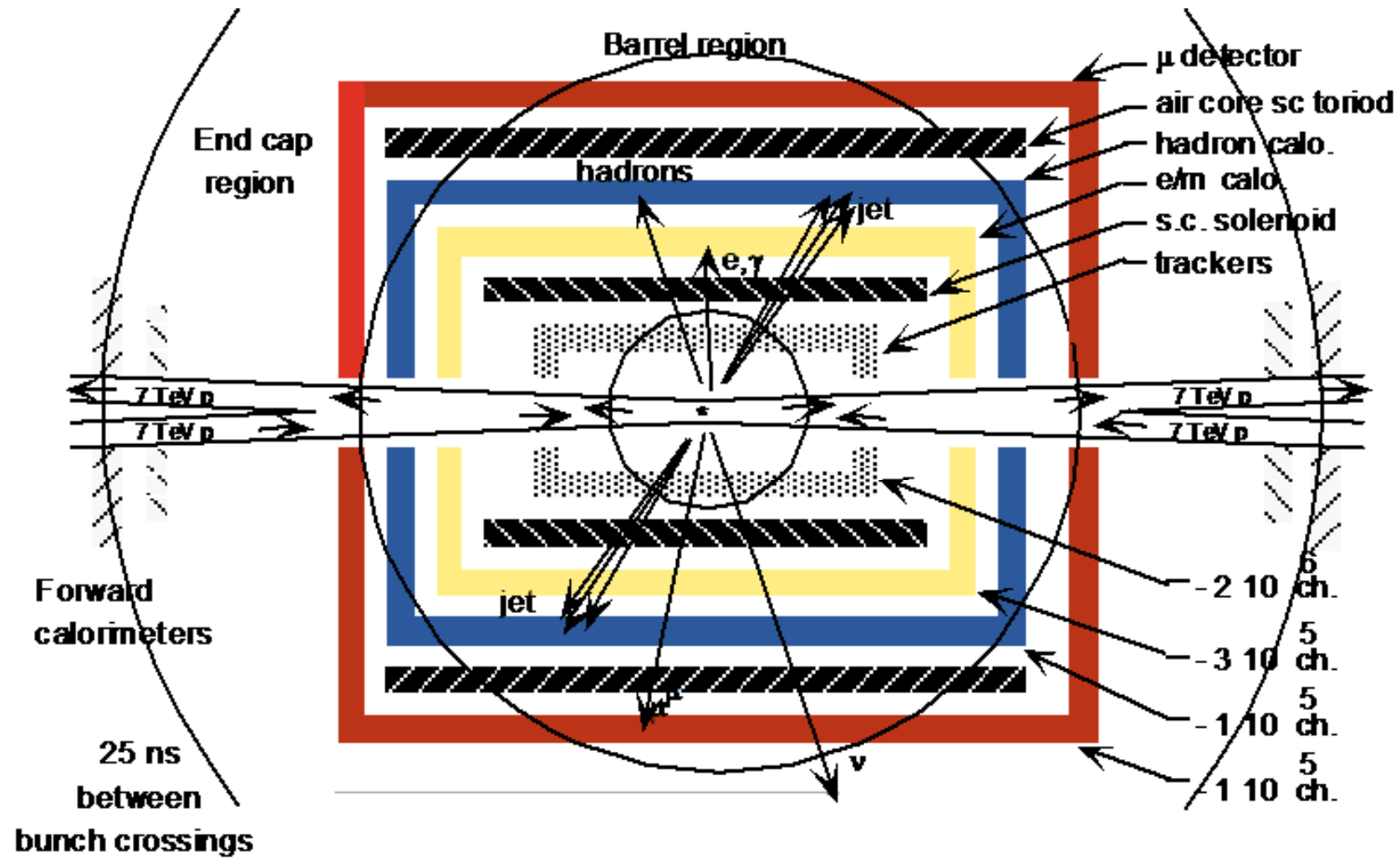

The CERN Accelerator Systems

A hierarchical system of accelerators

Lineac 2 → PS Booster → PS → SPS → LHC

50 MeV 1.4 GeV 25 GeV 450 GeV 6.5 TeV

One or two injections into LHC per day

450 GeV injected protons accelerate to 6.5 TeV
in 20 minutes

Aim for 7 TeV 2021

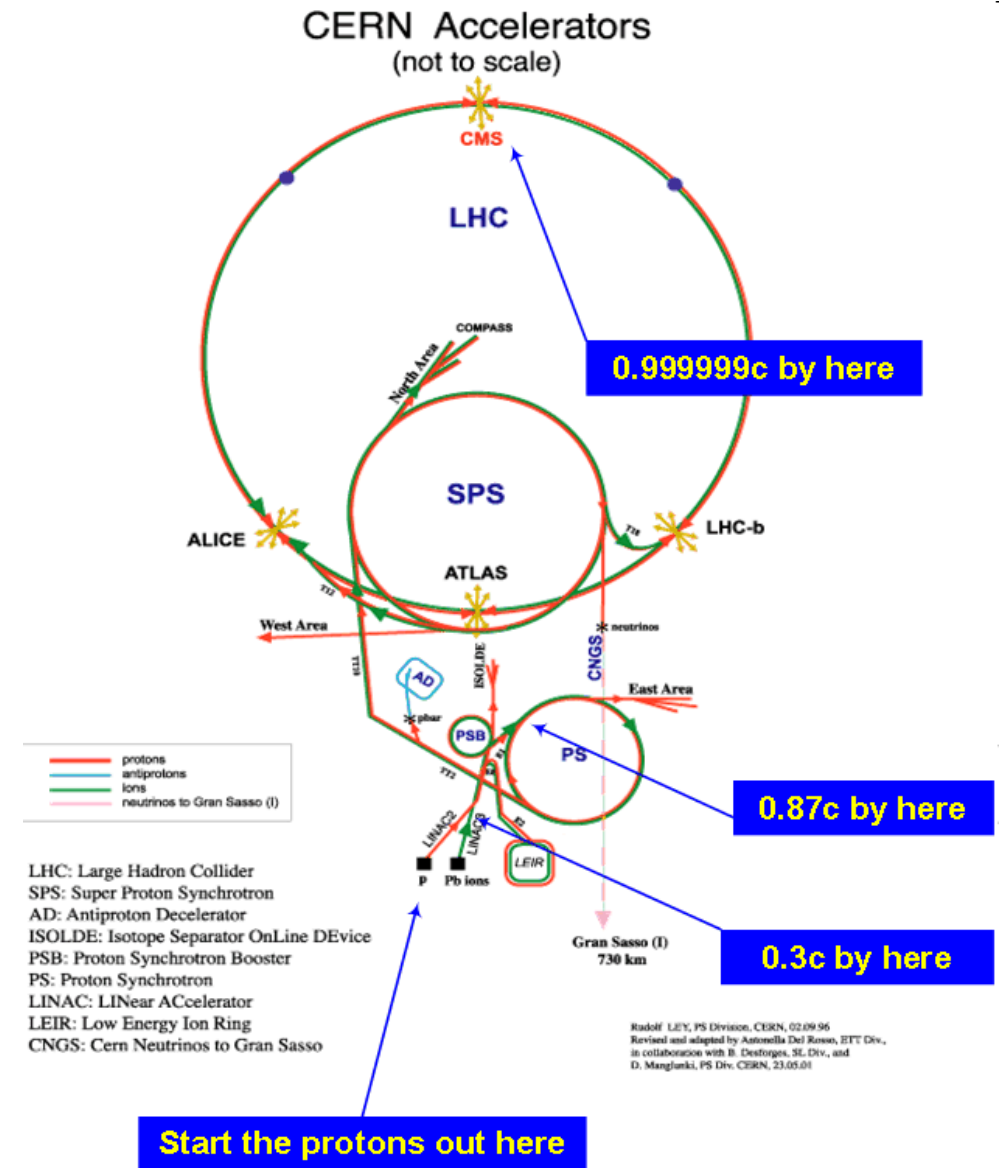

Desirable detector properties

- High precision inner detector position information to identify secondary vertices, but amplitude information is not needed – many layers and many channels
- It should be a light construction that does not compromise calorimeter resolution
- Good energy information in calorimeters and muon detector to determine missing momentum accurately
- All detectable particles should be detected – hermeticity
- Detector signals are often long, many bunch crossings, but must be associated with correct bunch crossing, if not, false missing momentum – **pile-up** problem at high count rates
- E/M calorimeter should be deep enough to contain electrons and γ
- Hadron calorimeter should be deep enough to contain hadrons
- Radiation levels determine choice of detectors and electronics



Design compromises necessary for economical reasons

LHC Detectors

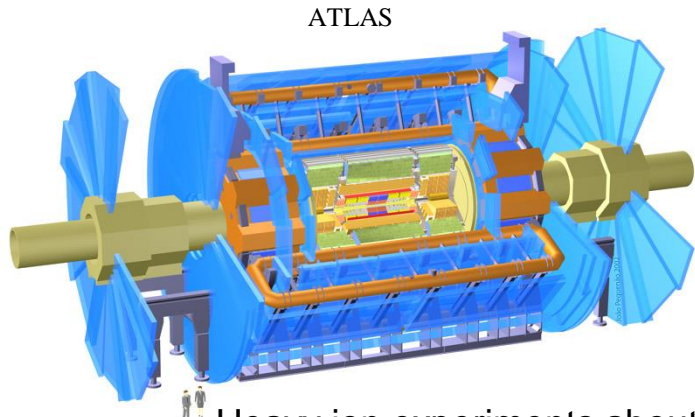

ATLAS
Heavy ion experiments about 2 weeks/year

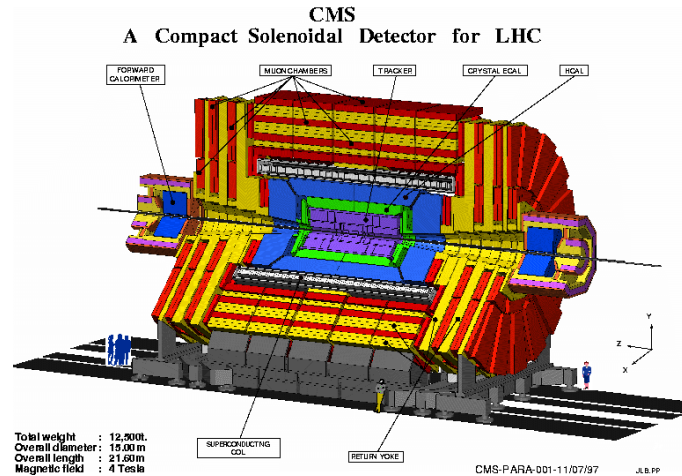

ATLAS -CMS
Similar but different – magnet system,
detector solutions, TDAQ system
Competition – Collaboration

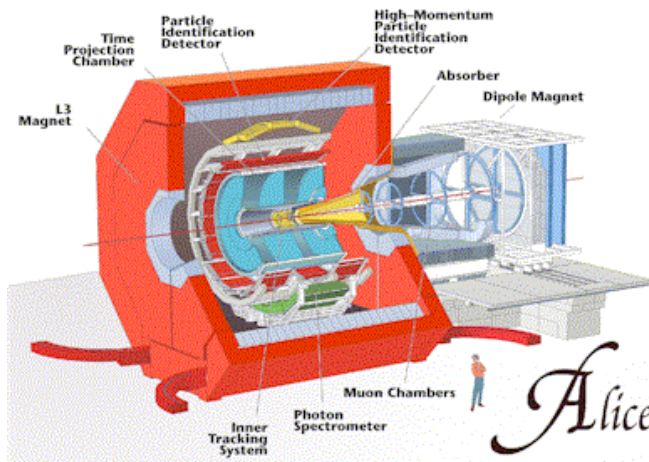

Heavy ion experiments,
Pb – Pb or Au – Au

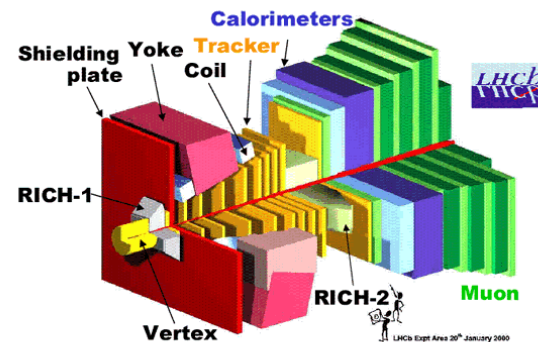

B physics at lower luminosities

LHC results and cost

RESULTS so far

Higgs particle discovered 2012 July 4th (Nobel prize 2013)

No strong indications for BSM physics (Beyond Standard Model) yet

No SUSY (SuperSymmetry) yet

COSTS

LHC material costs ~3.1 G€

ATLAS material costs ~.3 G€

A Toroidal Apparatus - ATLAS

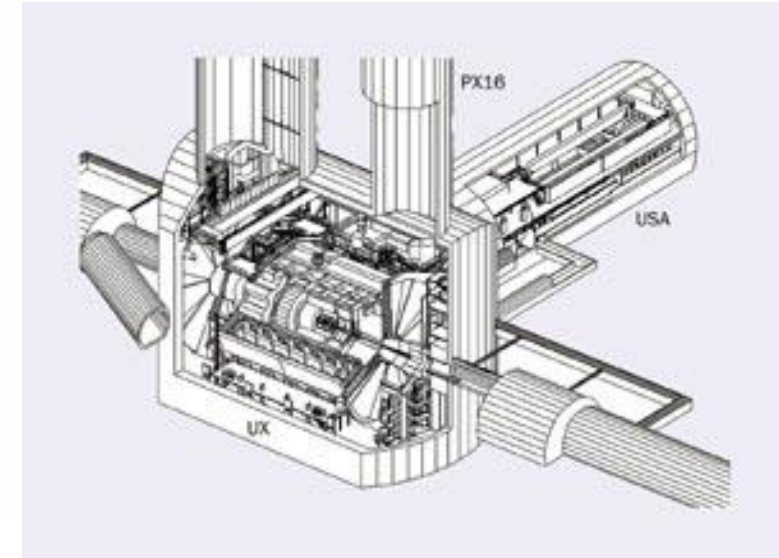
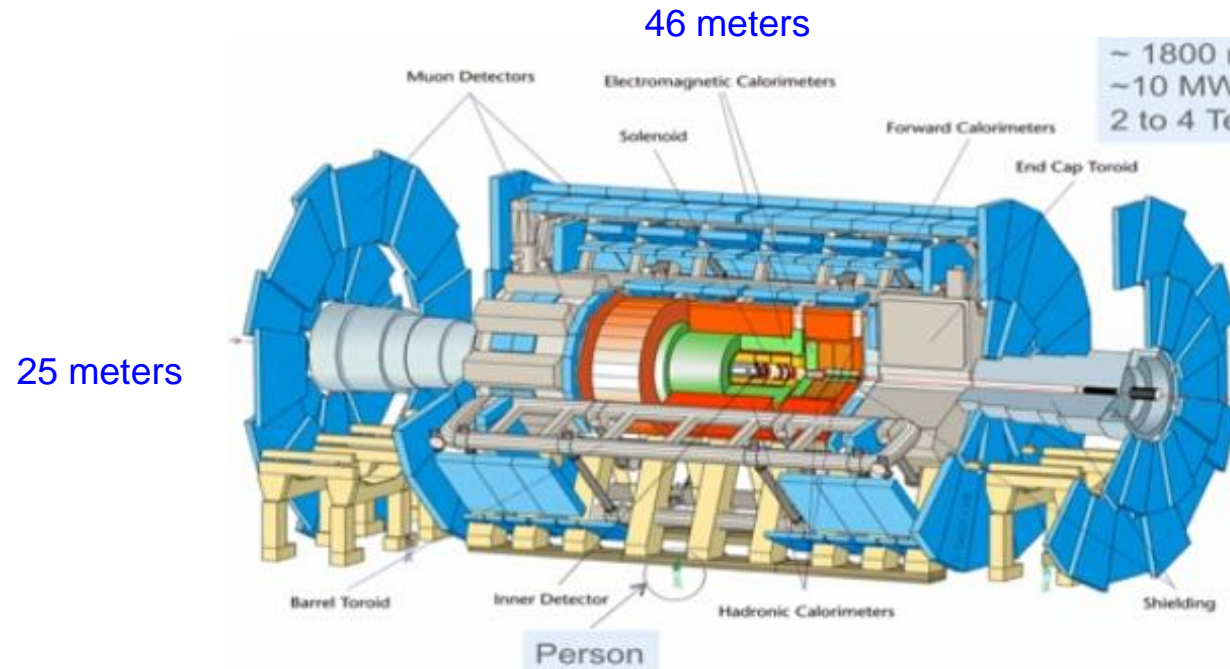

USA = Underground Storage Area
100m below surface
Access shafts 12 – 22 m diam.

Inner detector 1 bit? - ~86 Mch

E/M calorimeter 16 bit - ~300 kch

Hadron calorimeter 16 bit ~10kch

Muon detector x bit ~100 kch

Weight 7000 tons

3000 physicists + x engineers

181 institutes from

38 countries

A Toroidal Apparatus - ATLAS

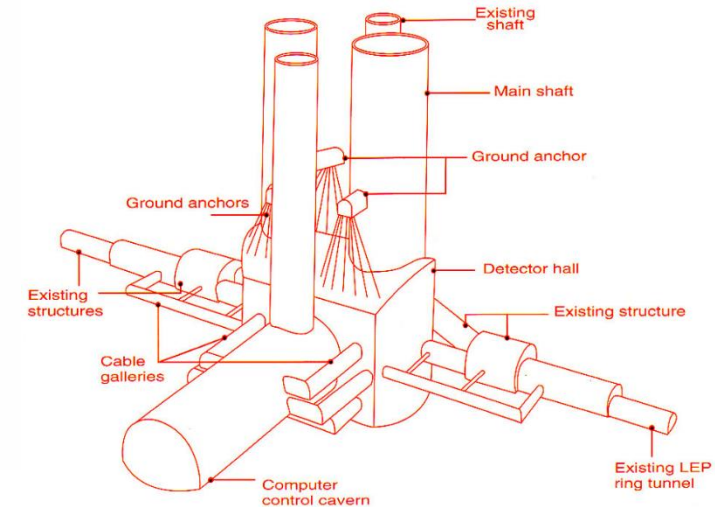
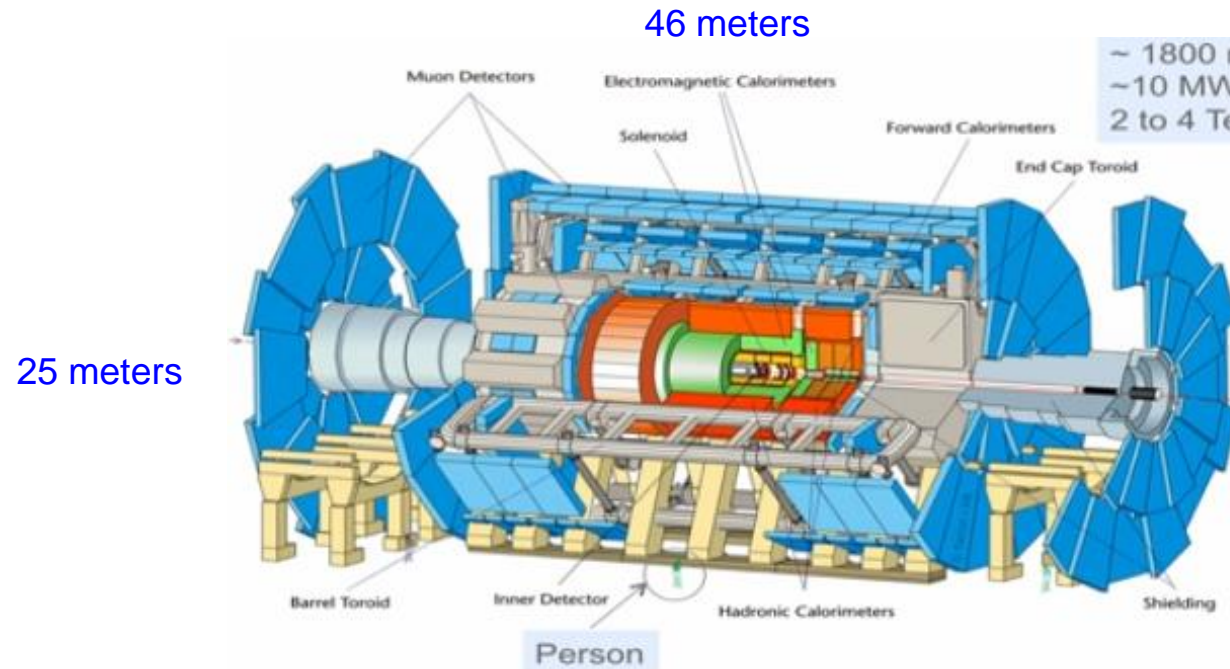

USA = Underground Storage Area
 100m below surface
 Access shafts 12 – 22 m diam.

Inner detector 1 bit? - ~86 Mch

E/M calorimeter 16 bit - ~300 kch

Hadron calorimeter 16 bit ~10kch

Muon detector x bit ~100 kch

Weight 7000 tons

3000 physicists + x engineers

174 institutes from

38 countries

CMS – Compact Muon Solenoid

36 Nations, 159 Institutions, 1940 Scientists (February 2003)

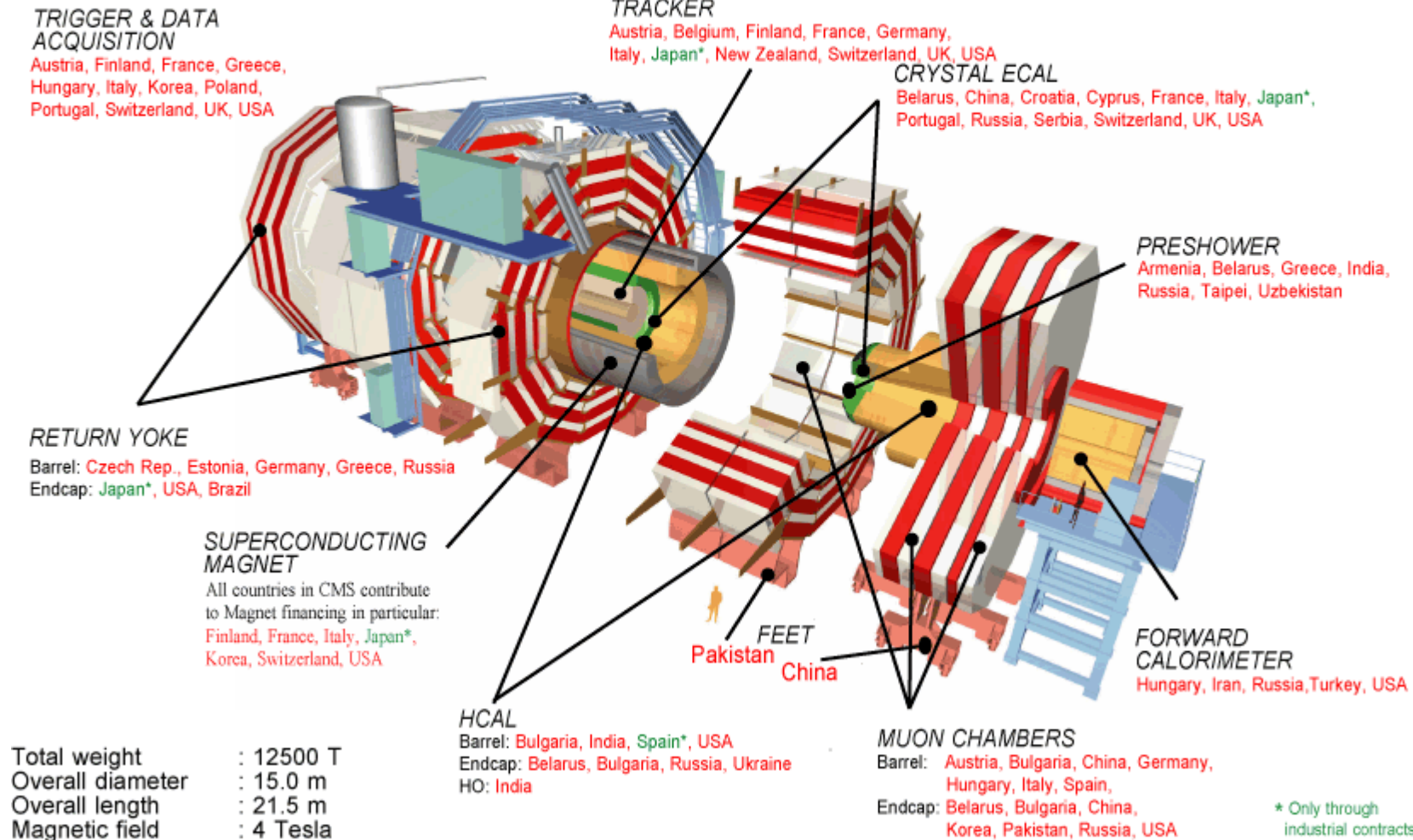

ATLAS installation

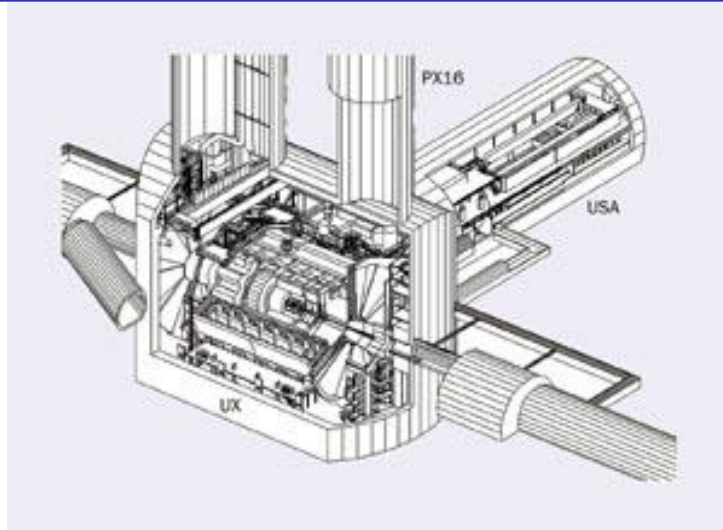

ATLAS installation



Radiation Detectors

A large class of radiation detectors are based on **scintillation** where the ionizing radiation excites an inorganic or organic scintillator. When the scintillator de-excites it emits light of characteristic wavelengths.

The light can be collected by **photo multipliers** or silicon light sensors.

In another class of radiation detectors the radiation **ionizes the media** and an electric field separates the electrons and the ions. The media can be gaseous or liquid. Different media gives different performance.

In semiconductor detectors the radiation creates **electron-hole pairs** that are separated by the field over a p-n junction.

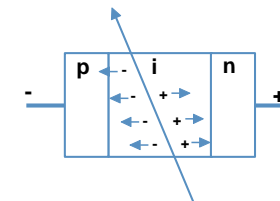
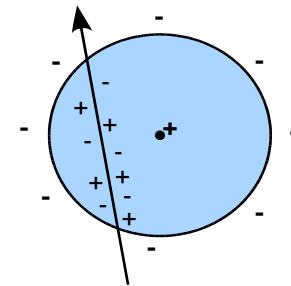
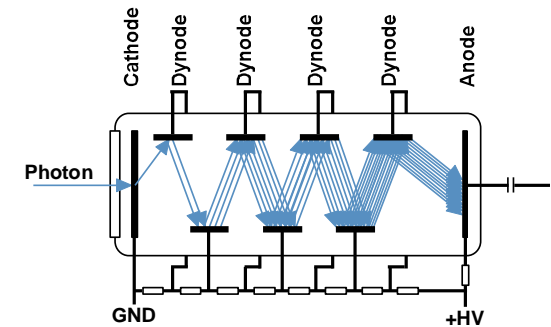
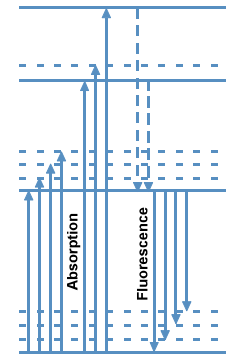

ATLAS inner detector

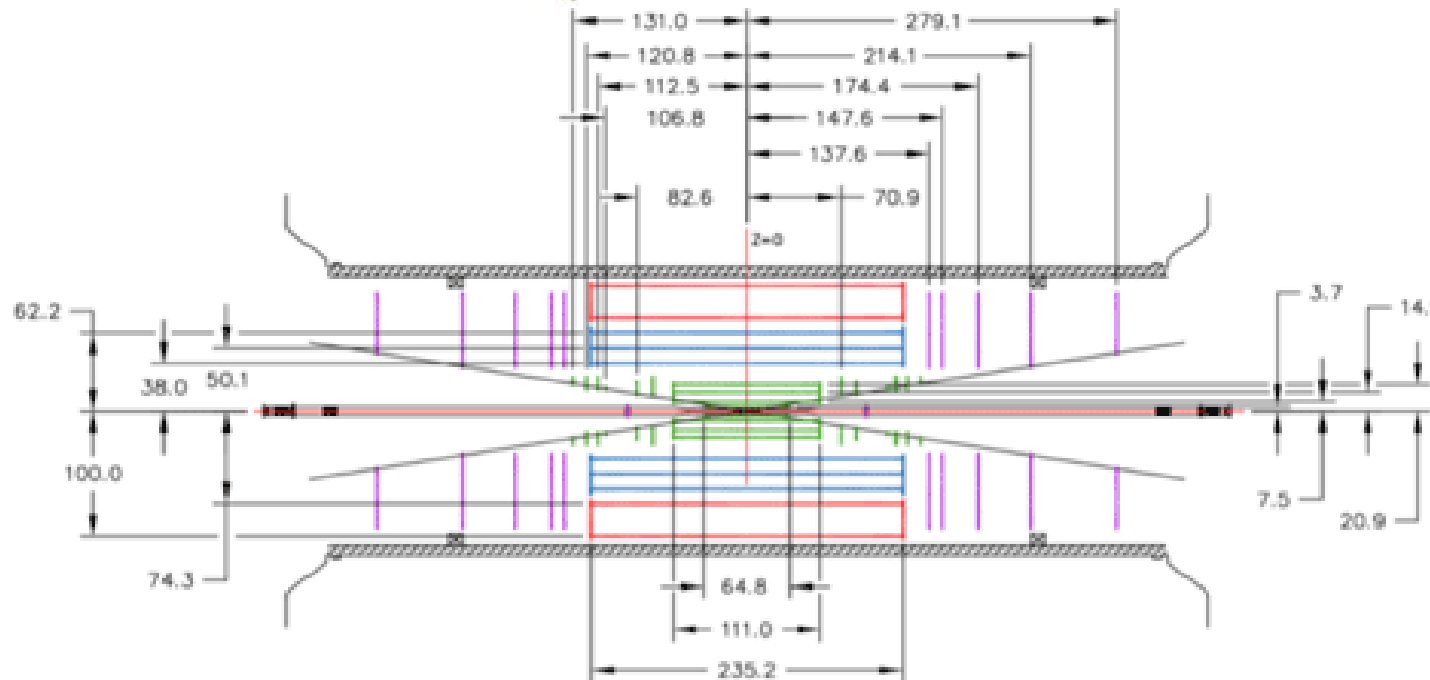
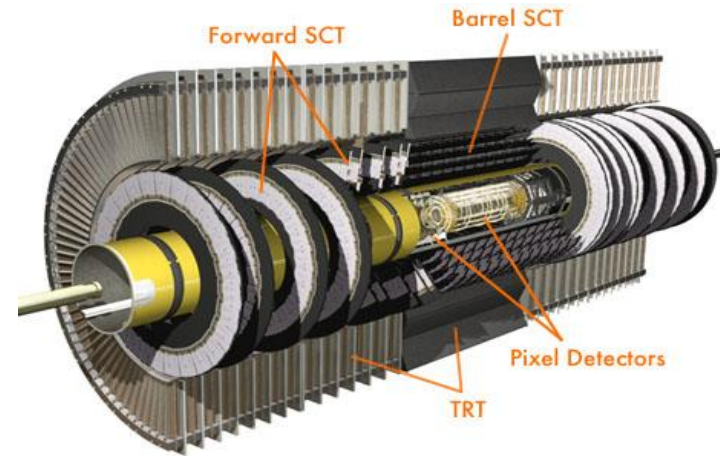
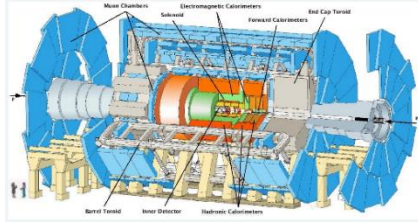

Magnetic field 2T
3 different detector types

Pixel detector 80 Mch
Silicon pad detector 2D resolution $12\ \mu \times 110\ \mu$

Semiconductor Tracker (SCT) 6 Mch
Silicon strip detector (1D)
Double layers Resolution $23\ \mu \times 800\ \mu$

Transition Radiation Tracker (TRT)
300kch
Gas detector – straw tubes
Electron identification

ATLAS inner detector

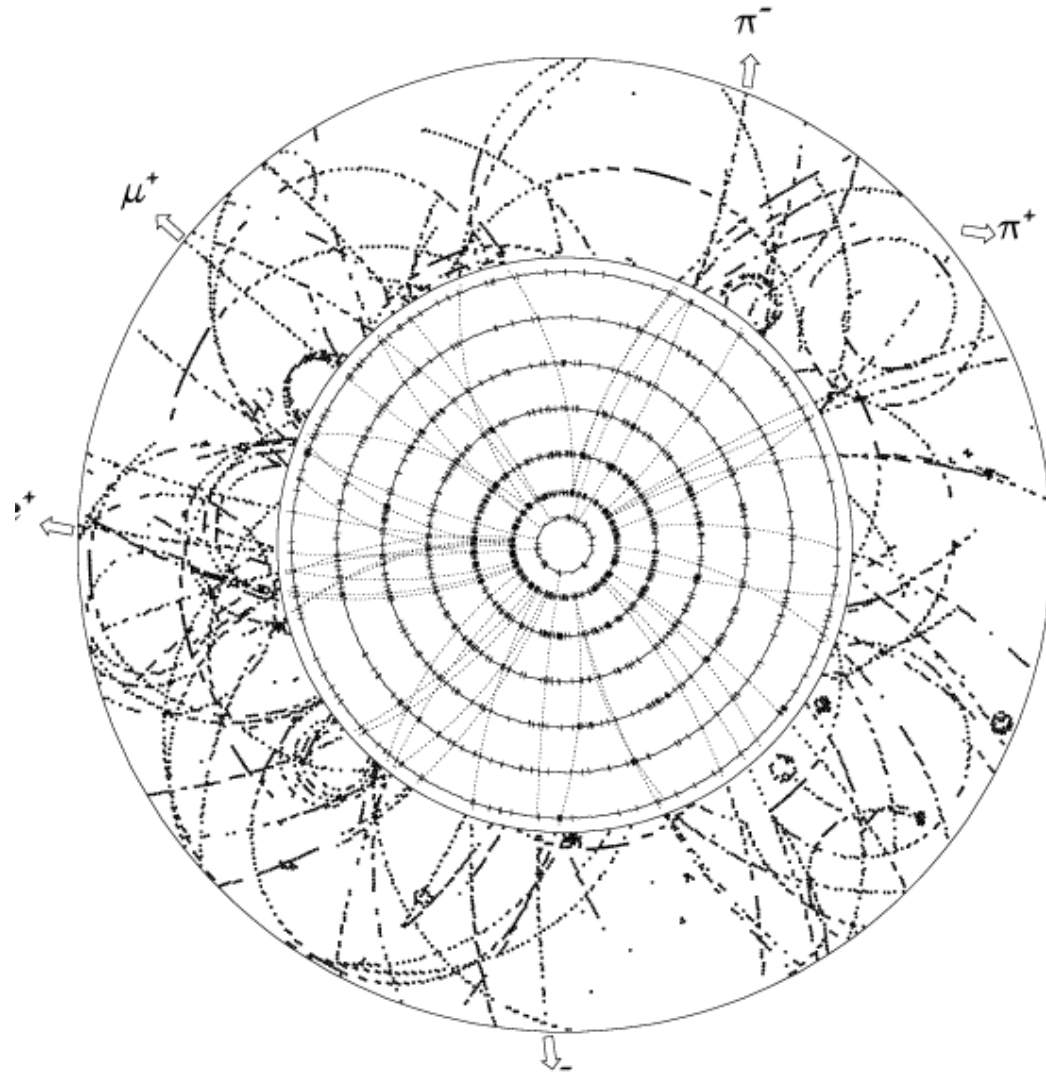

About 1000 particles

Magnetic field 2T
3 different detector types

Pixel detector 80 Mch
Silicon pad detector 2D resolution $12\ \mu \times 110\ \mu$

Semiconductor Tracker (SCT) 6 Mch
Silicon strip detector (1D)
Double layers Resolution $23\ \mu \times 800\ \mu$

Transition Radiation Tracker (TRT)
300kch
Gas detector – straw tubes
Electron identification

Pixel detector 3 sample points
Strip detector 4 sample points
TRT 36 sample points

ATLAS inner detector

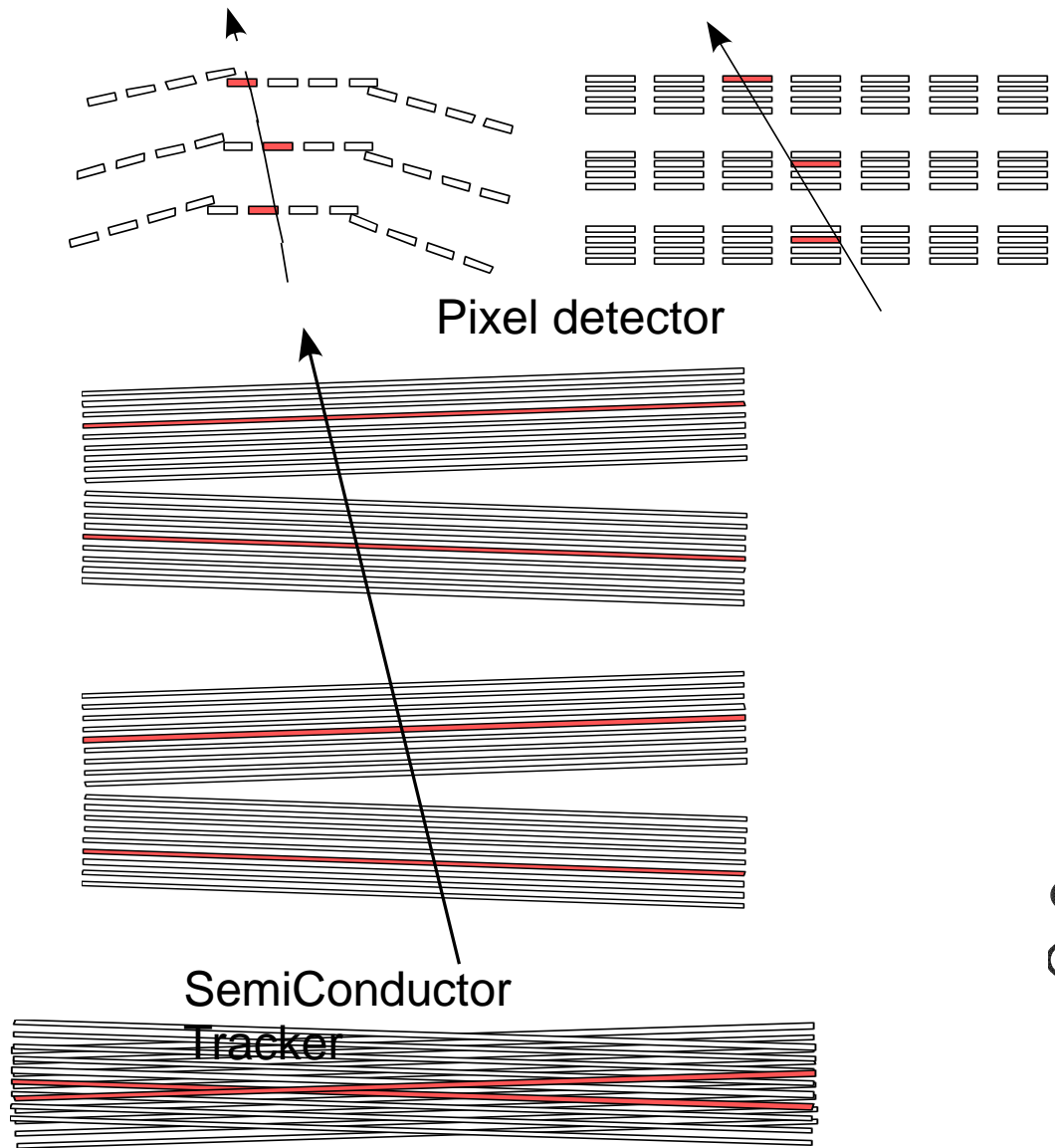

Magnetic field 2T
3 different detector types

Pixel detector 80 Mch
Silicon pad detector 2D resolution $12 \mu \times 110 \mu$

Semiconductor Tracker (SCT) 6 Mch
Silicon strip detector (1D)
Double layers Resolution $23 \mu \times 800 \mu$

Transition Radiation Tracker (TRT)
300kch
Gas detector – straw tubes
Electron identification

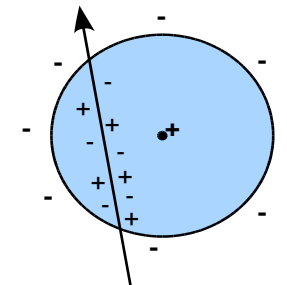
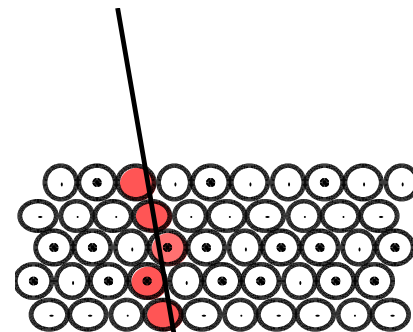

ATLAS inner detector

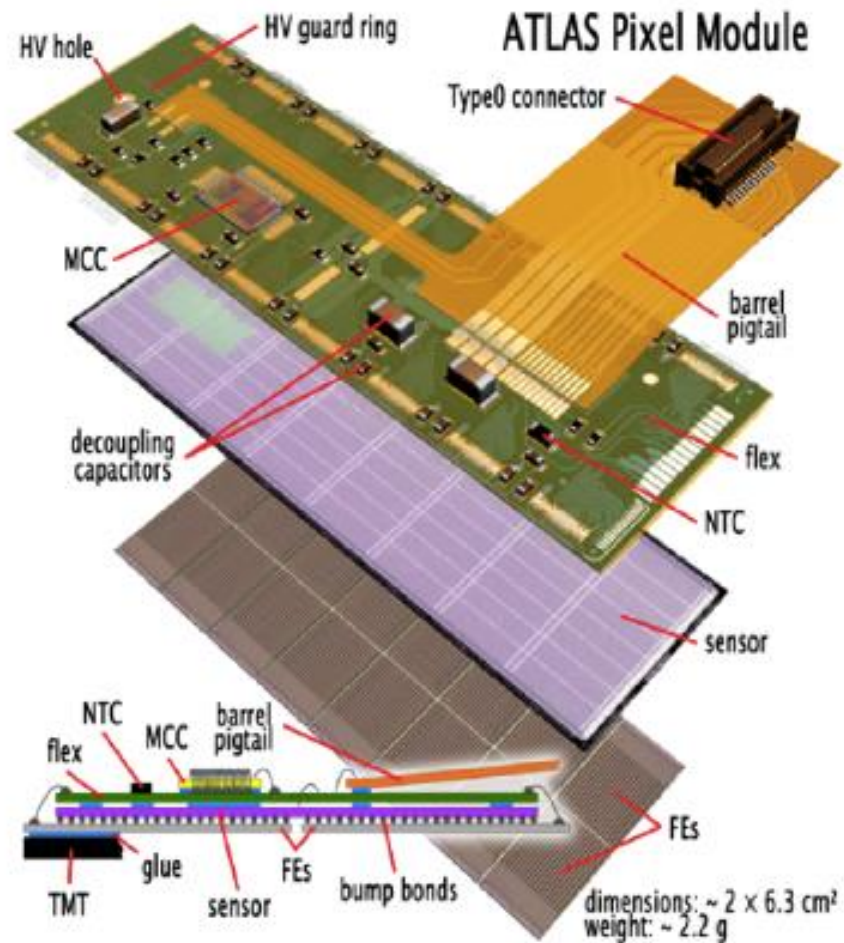

Radiation tolerance, power and cooling problematic

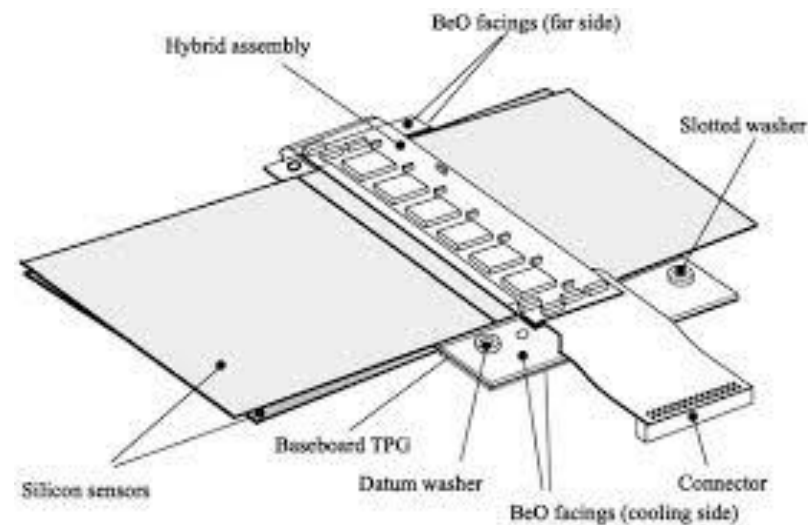

Liquid Argon e-m calorimeter

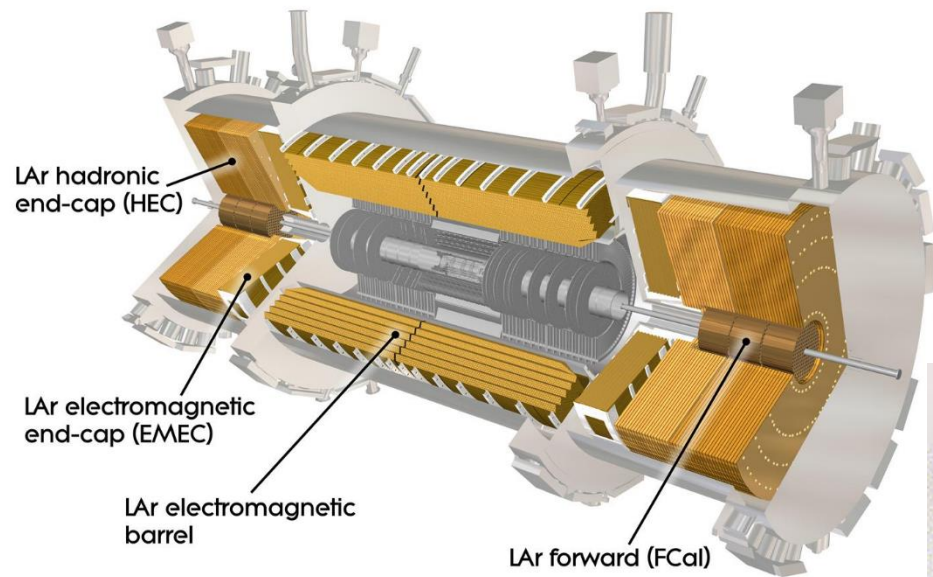

Liquid Argon-Lead/stainless steel calorimeter (87°K)

16-bit dynamic range

Cooled preamplifiers

4 layers + presampler

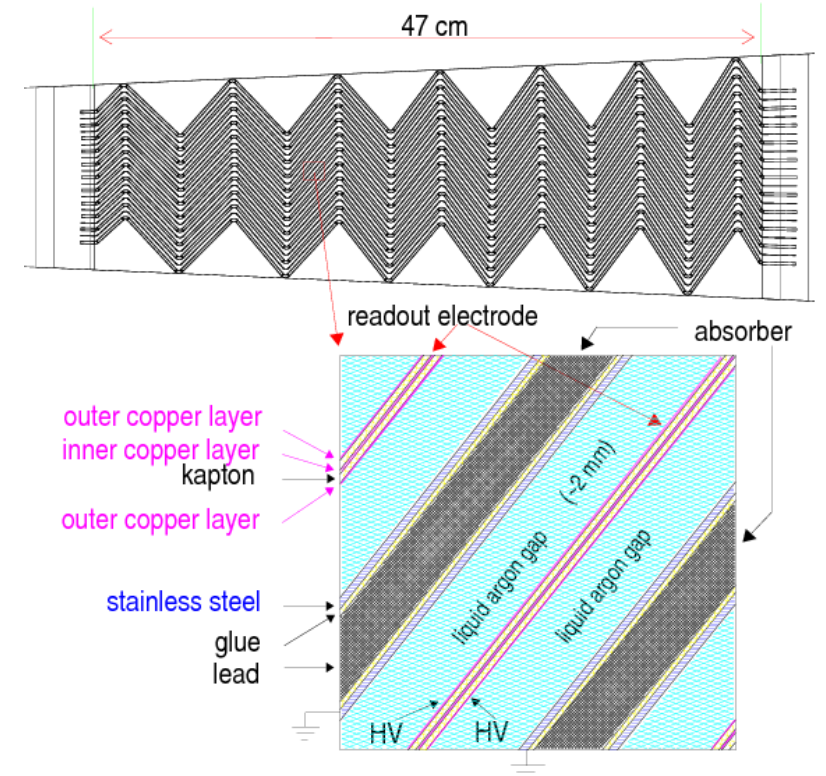
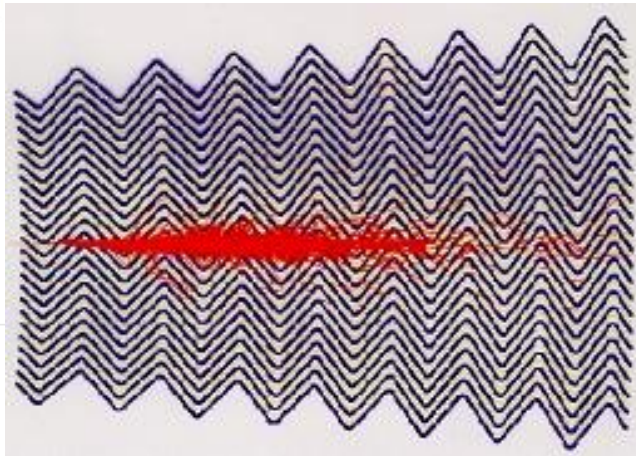
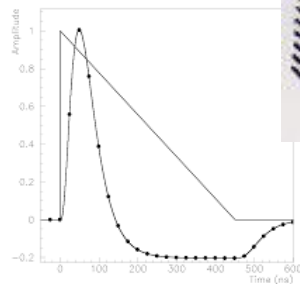

TileCal hadron calorimeter

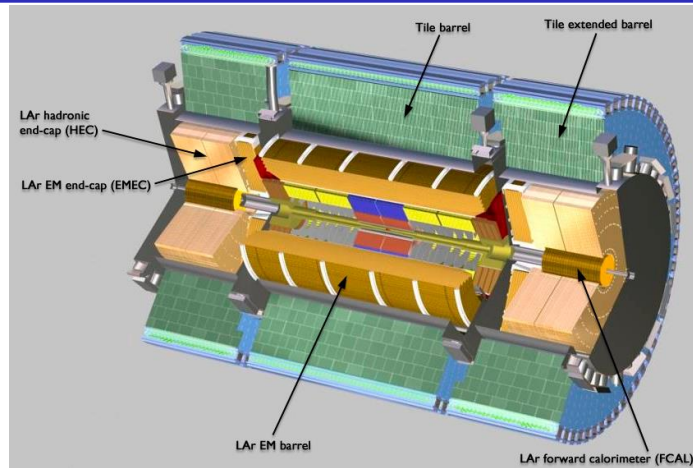

Interleaved steel and scintillator tiles

256 modules, each weighing 10 tons

4 depth layers

Coarse spatial but good amplitude resolution

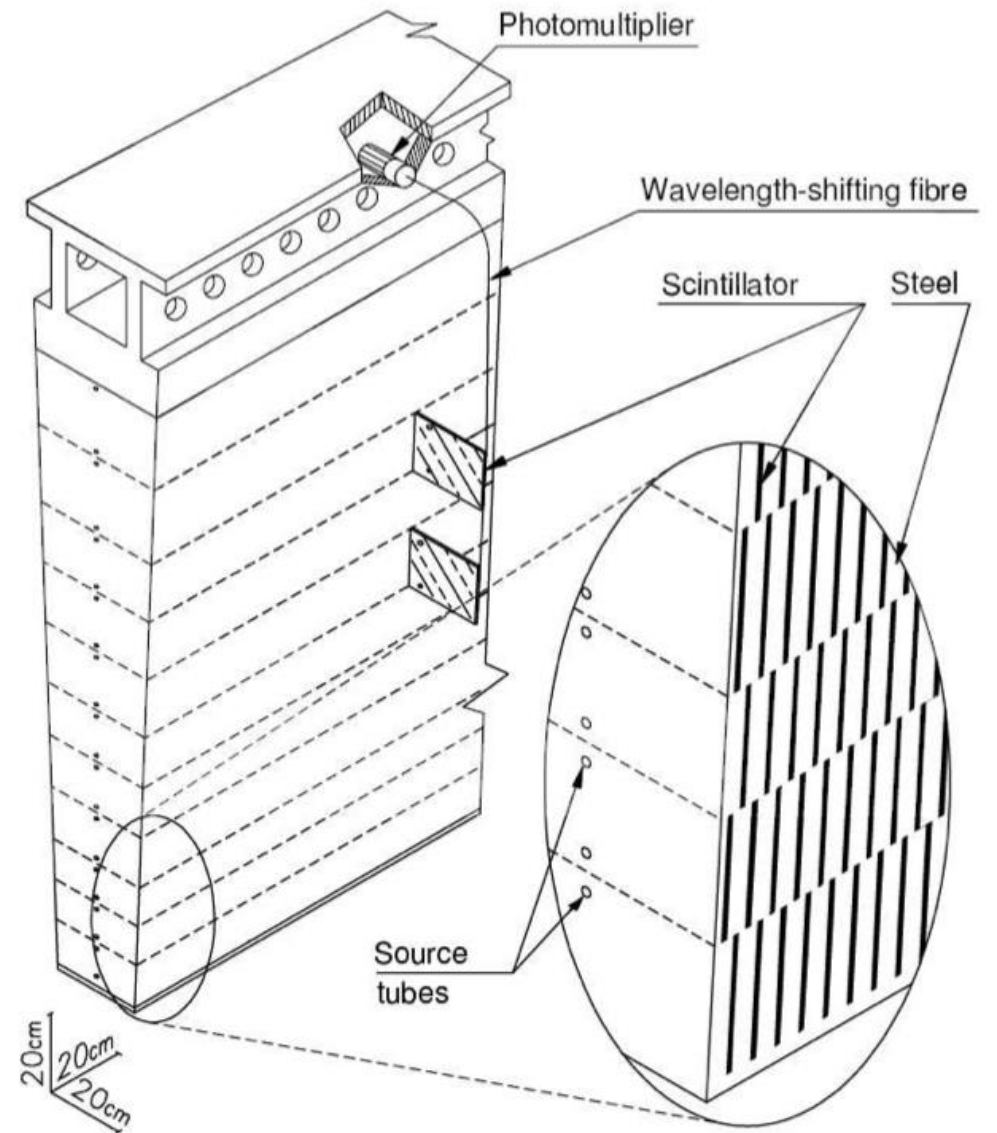
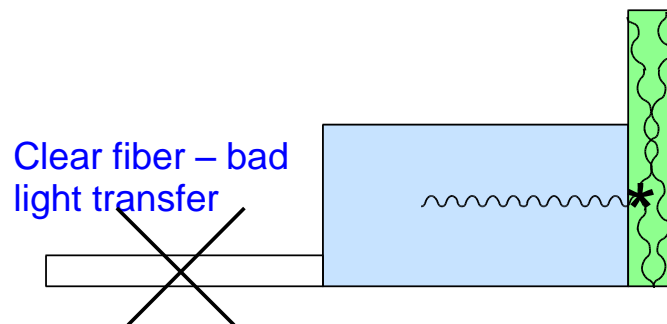

The Muon Spectrometer

Geometrical alignment precision $30 \mu\text{m}$

Alignment can change due to temperature change or deformations when the magnet field is changed

Cost → Use gas detectors, different types for precision and trigger and different types for normal and high intensity regions, close to beam pipe

MDT (Monitored Drift Tubes) and CSC (Cathod Strip Chambers) for high precision. CSC for high intensity forward regions

RPC (Resistive Plate Chambers) and TGC (Thin Gap Chambers) for trigger. TGC for high intensity regions.

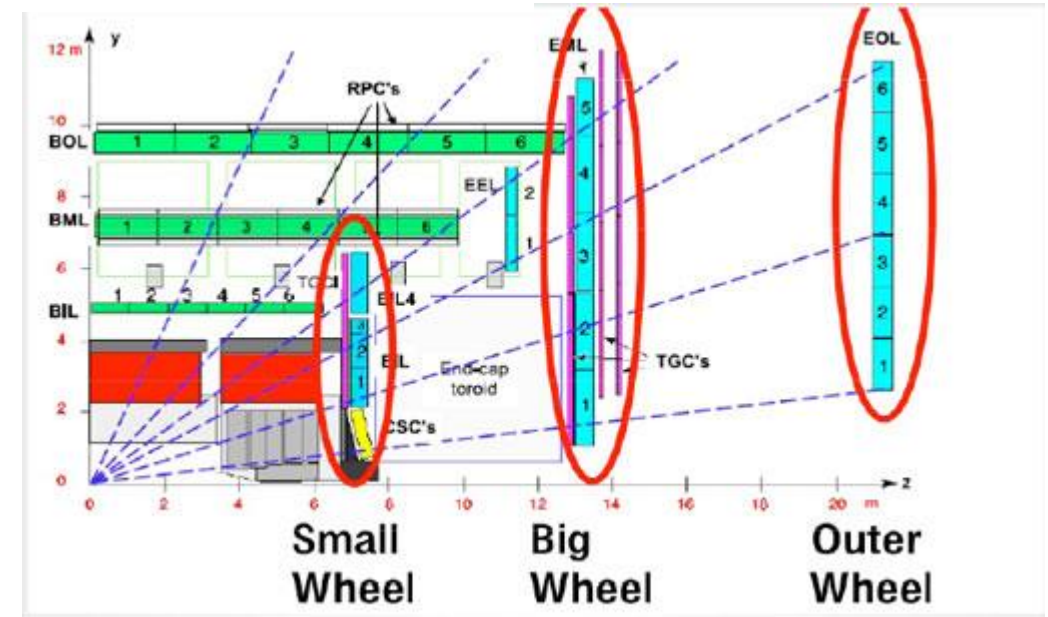
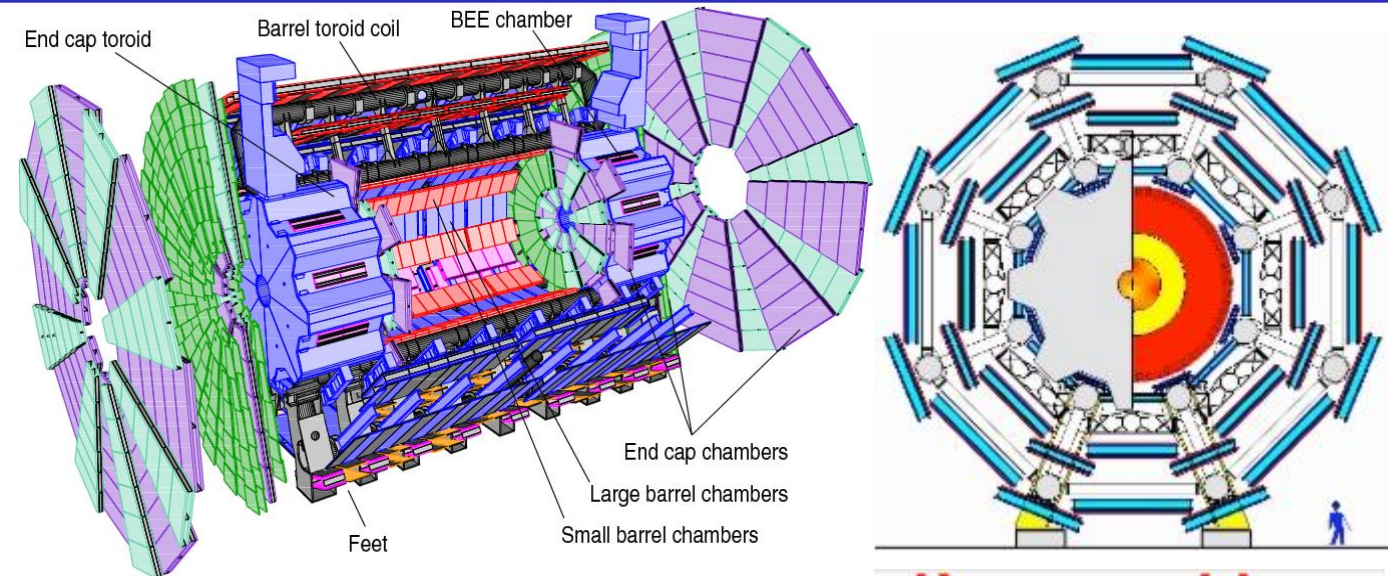

The Muon Spectrometer

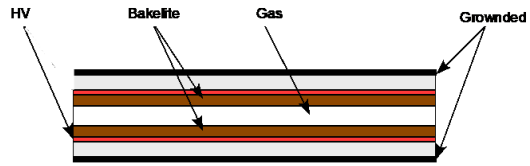

RPC – Resistive Plate Chamber

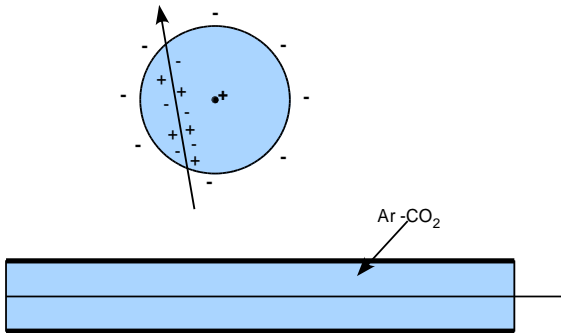

MDT – Monitored Drift Tubes

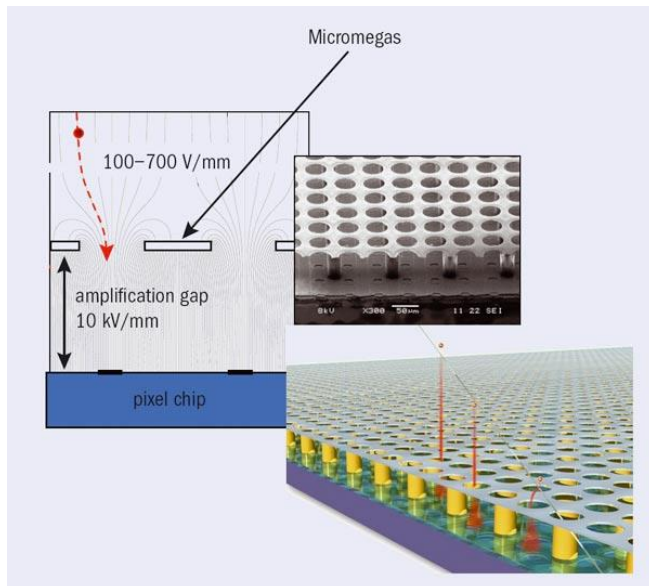

Micromegas for muon detector upgrade

Trigger and Data Acquisition (TDAQ)

Reading out all data, every bunch crossing, completely impossible 2008 - data transfer limitations
Solution -> use multilevel trigger – data storage limitations, radiation tolerance

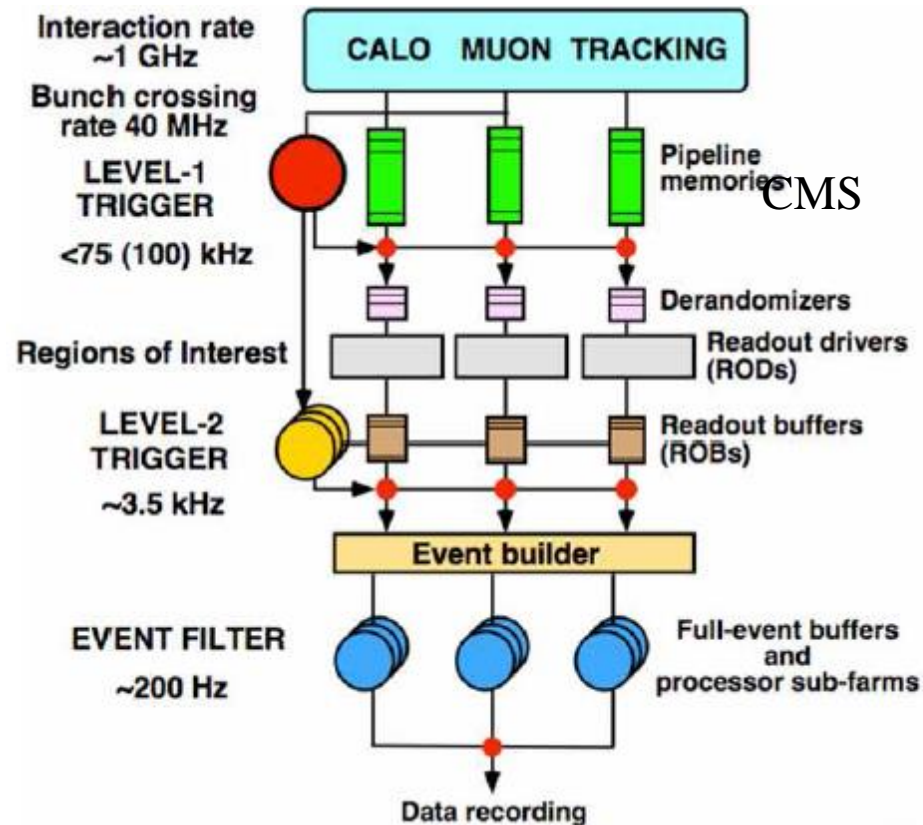

Trigger and Data Acquisition (TDAQ)

First level trigger – pipe-lined processing (in FPGAs) of merged calorimeter and muon data with reduced spatial and amplitude information - delivers Regions Of Interest

Second level trigger – PC based software processing full resolution data from all subdetectors but only from RIOs

Third level trigger – Event Builder – PC farm to on-line analyze all data at highest precision

A first selection criteria is to require large transverse energy components to guarantee a head-on collision

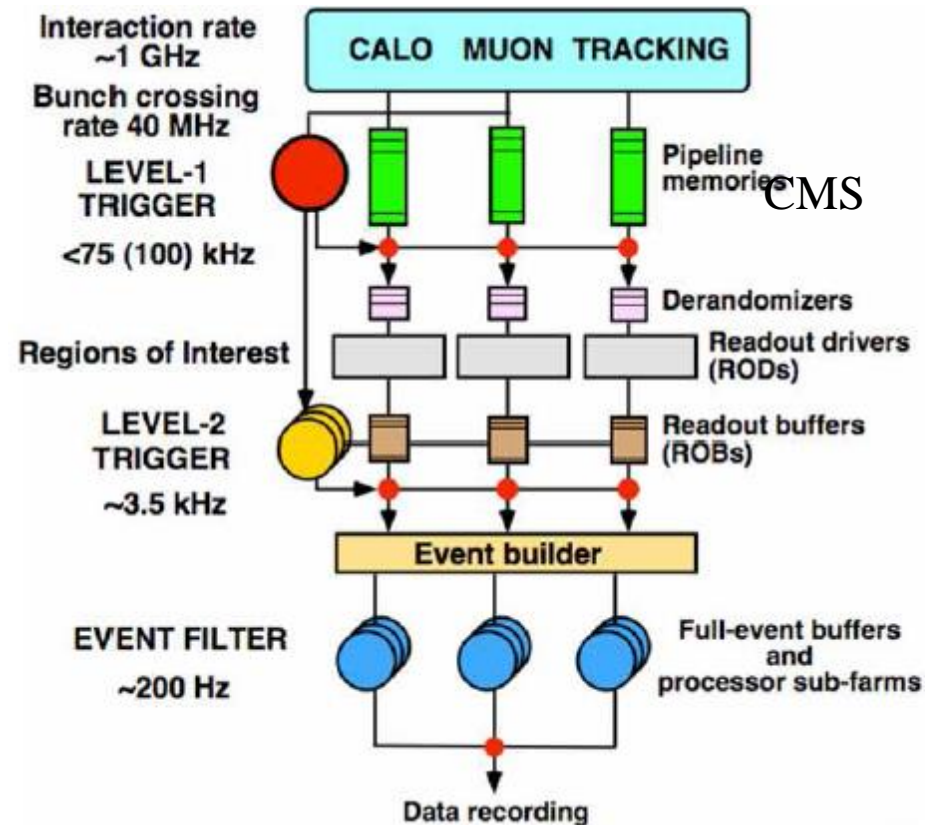

Trigger and Data Acquisition (TDAQ)

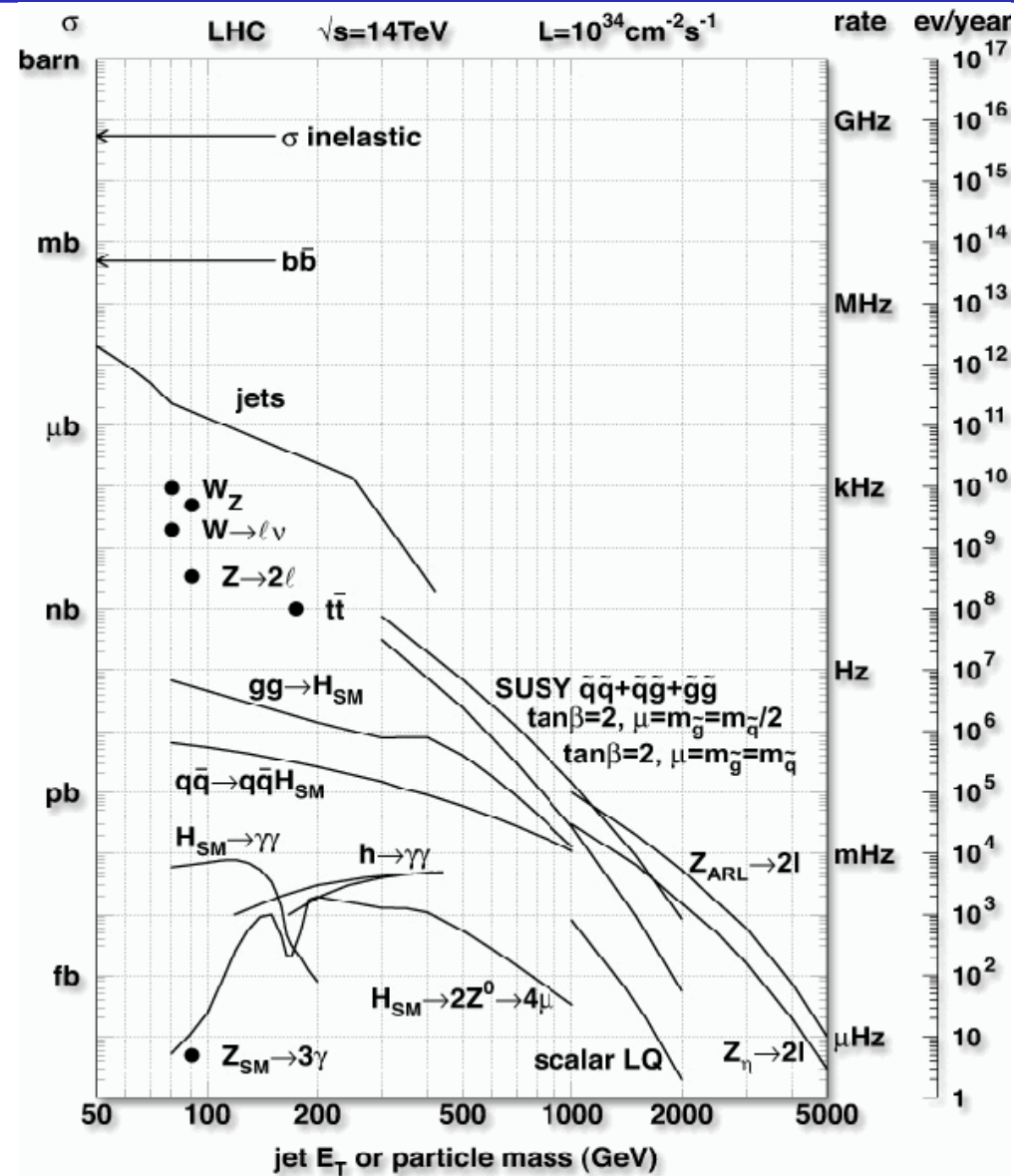

First level trigger

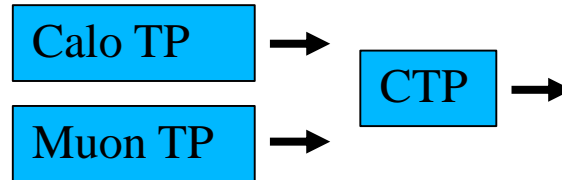

The Calorimeter trigger processor and the Muon trigger processor reports to the **Central Trigger Processor (CTP)**

CTP looks for characteristic signatures in the data that indicates that the data contains an interesting event e.g.

- 4 isolated electrons or
- 4 muons or
- 2 high energy electrons over a certain threshold and 2 jets
- etc.

The search criteria are defined in the **Trigger Menu** data base

The current Trigger Menu selection is defined at the start of a run

First level trigger

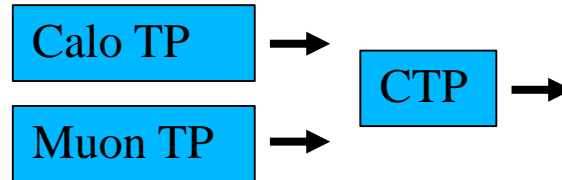

All data can be stored on the detector for maximum $2.5 \mu\text{s}$ – the **latency** of the first level trigger

Before this, a decision must be made on saving or not saving that data

The specified data latency allows for sending the data from the detector to the trigger processor in USA-15 (Underground Storage Area), process it and send the result back to the detector for possible transmission of the entire data set.

First level trigger

Each bunch crossing, i.e. each 25ns

4096 trigger data values arrive from LAr and Tile

64 cell rows around the calorimeter cylinder and 64 cells in each row along the detector

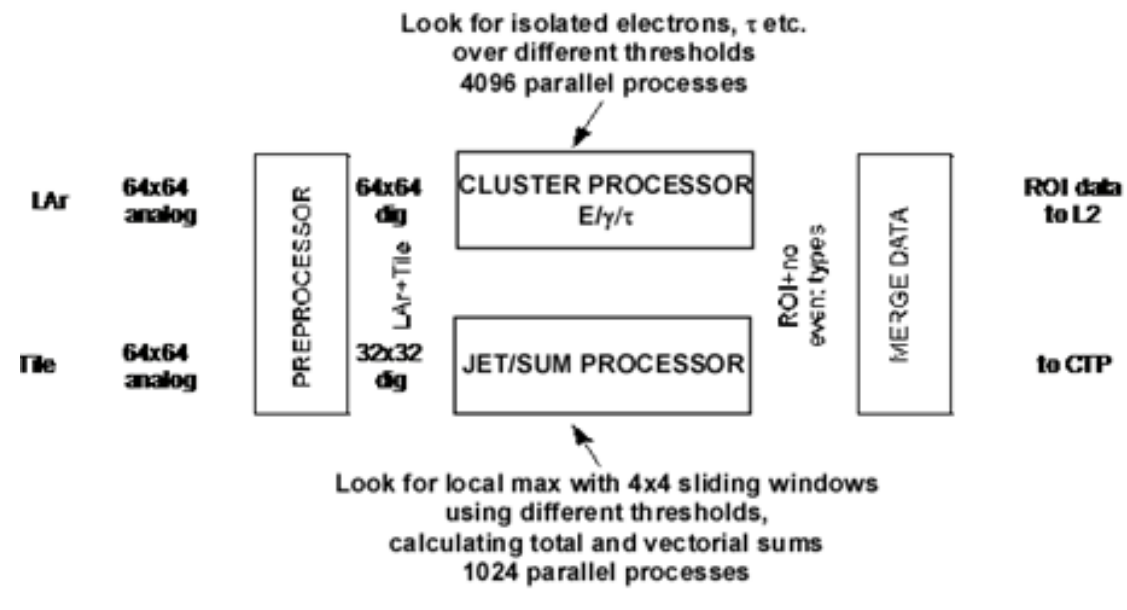
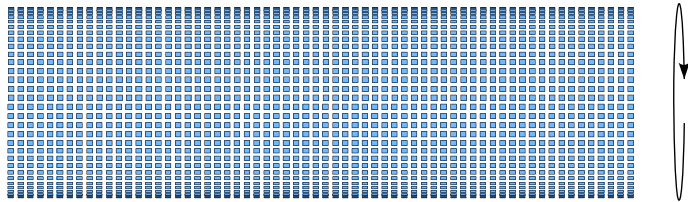

For each corresponding trigger cell one must study if it contained an interesting event
4096 parallel processes start every 25ns and should be completed within 1 μ s
FPGAs widely used together with pipelined processing

Pipelined Processing

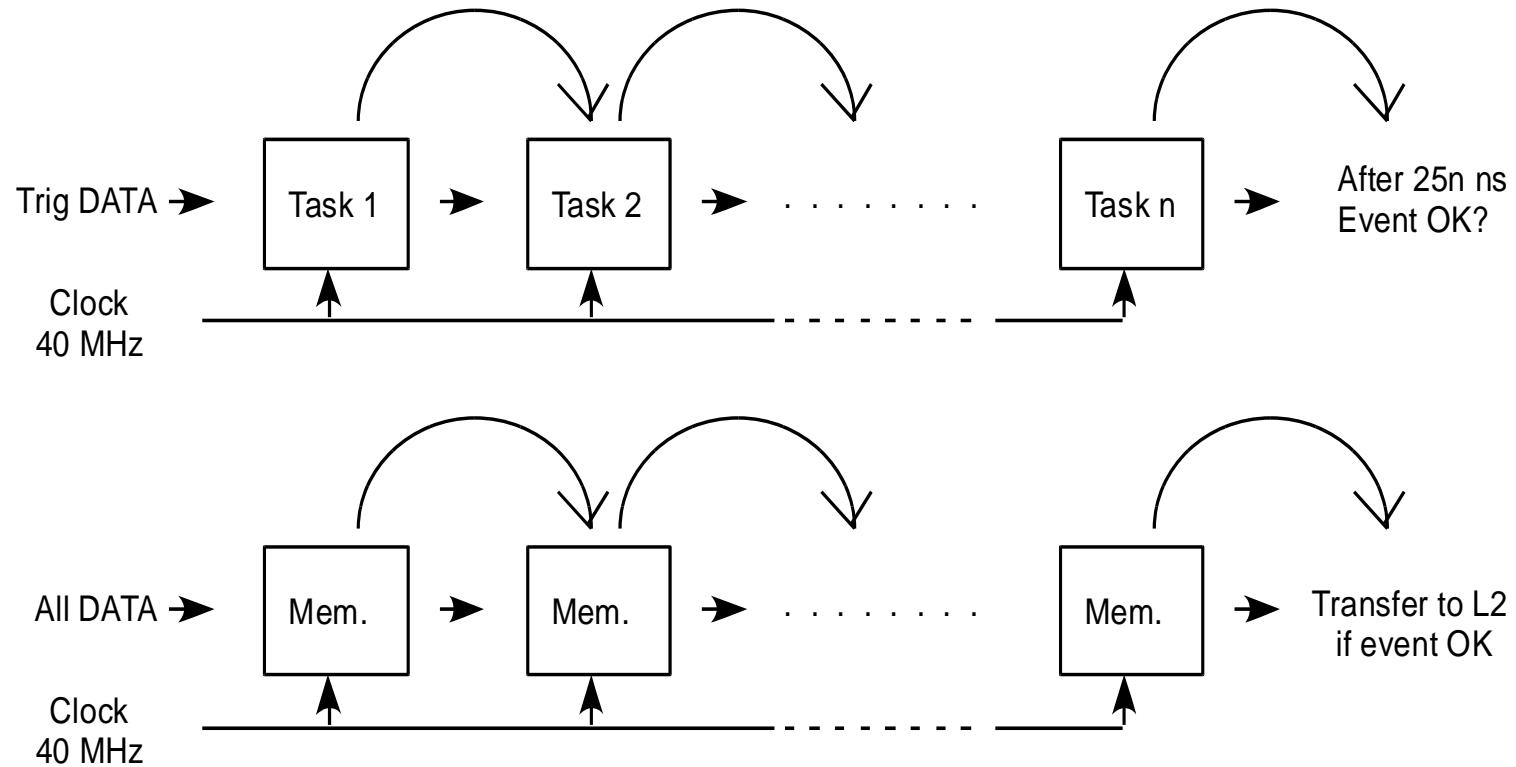

First level trigger

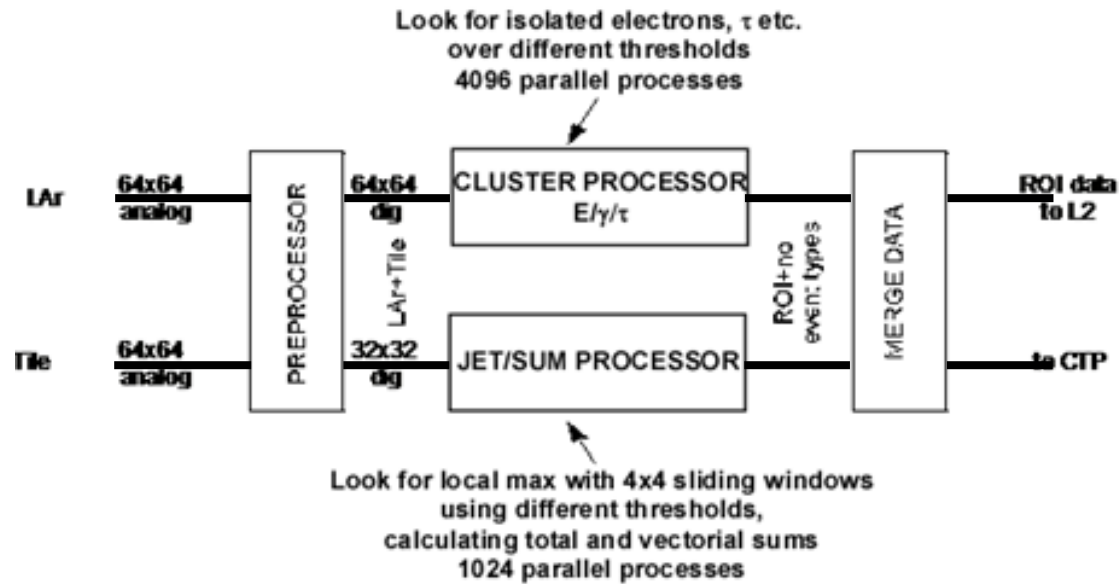

CLUSTER FINDING e/γ ALGORITHM

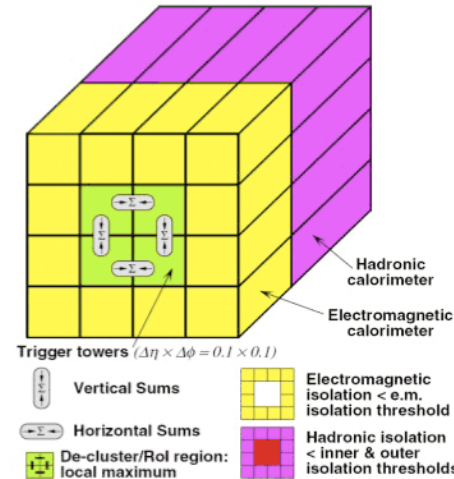

For each cell and each set of thresh.
Vert. SUM or Hor. SUM $>$ thresh.
Em isolation SUM $<$ thresh.
Had isolation SUM $<$ thresh.

JET MAX ALGORITHM

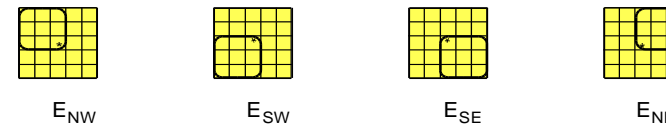
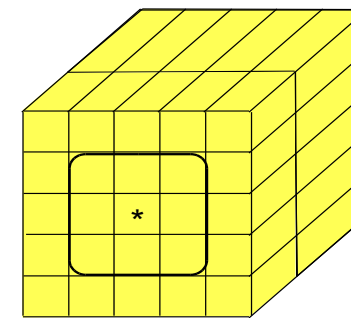

Synchronization

The Timing, Trigger and Control (TTC) system is responsible for synchronization

The accelerator clock 40.08 MHz distributed to all Front-End units with local phase control

L1A distributed to all FE-boards with programmable delay to maintain sync.

Addressed commands to configure local FE-boards

Maintains Bunch Crossing Identifier BCID to label events

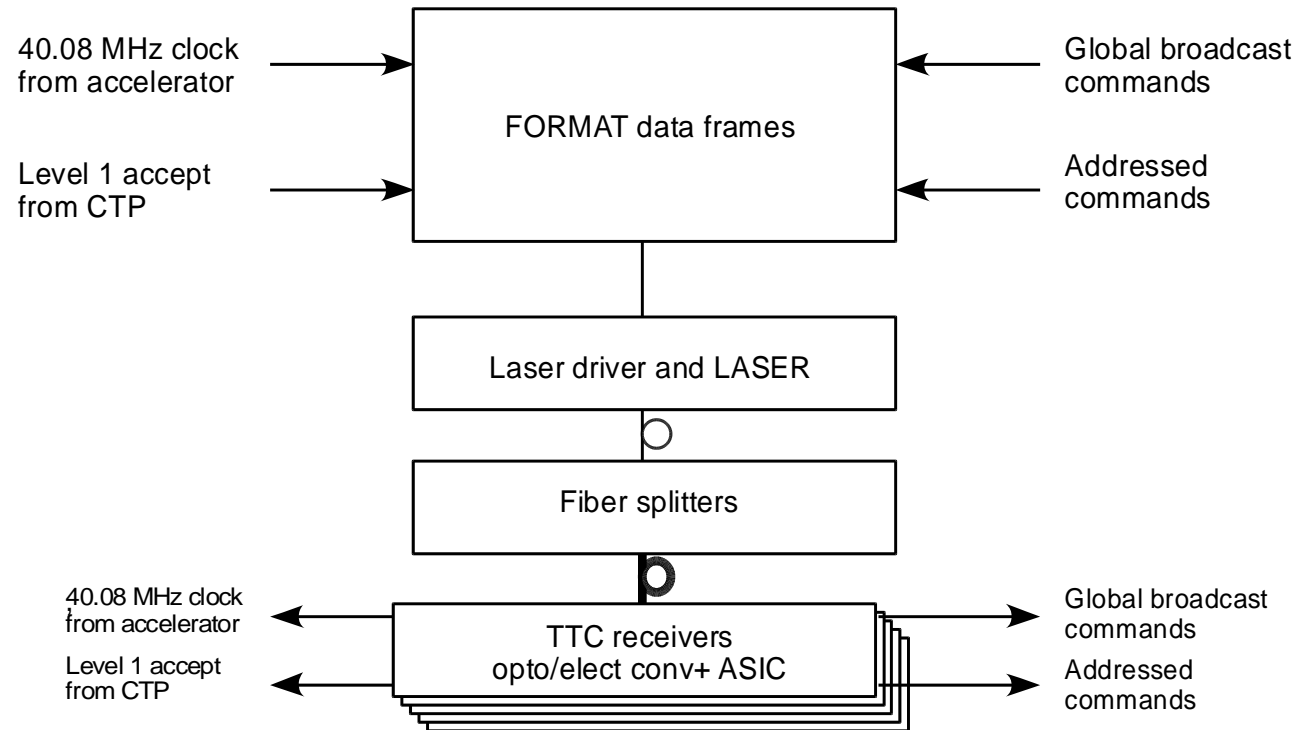

Detector Control - DCS

The Detector Control System or Slow Control, as it was called before, is responsible for initializing and monitoring of all system components including configuring programmable logic (FPGAs).

It will monitor parameters like temperatures, fan operation, pressures, voltages, currents, humidities, error conditions etc..

It is also responsible for safety functions and alarms

It records error conditions and archives monitored parameters

When supervising DCS it is important to have efficient and intuitive GUIs

ATLAS control room

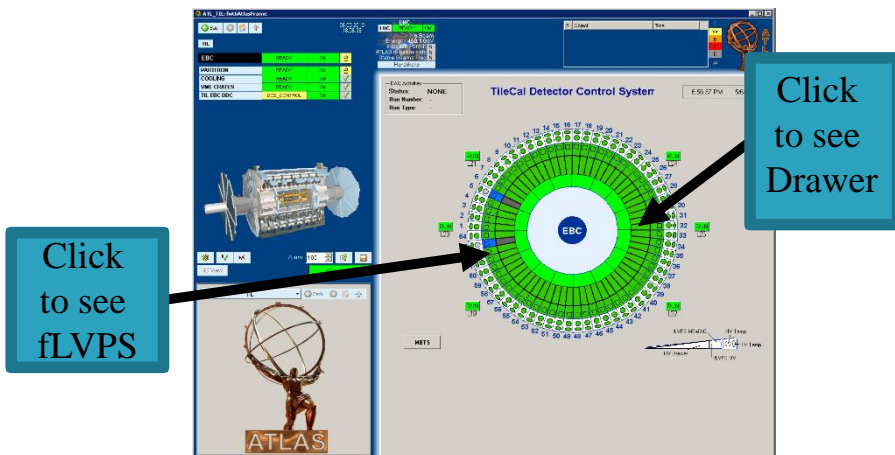

Front-End example - TileCal

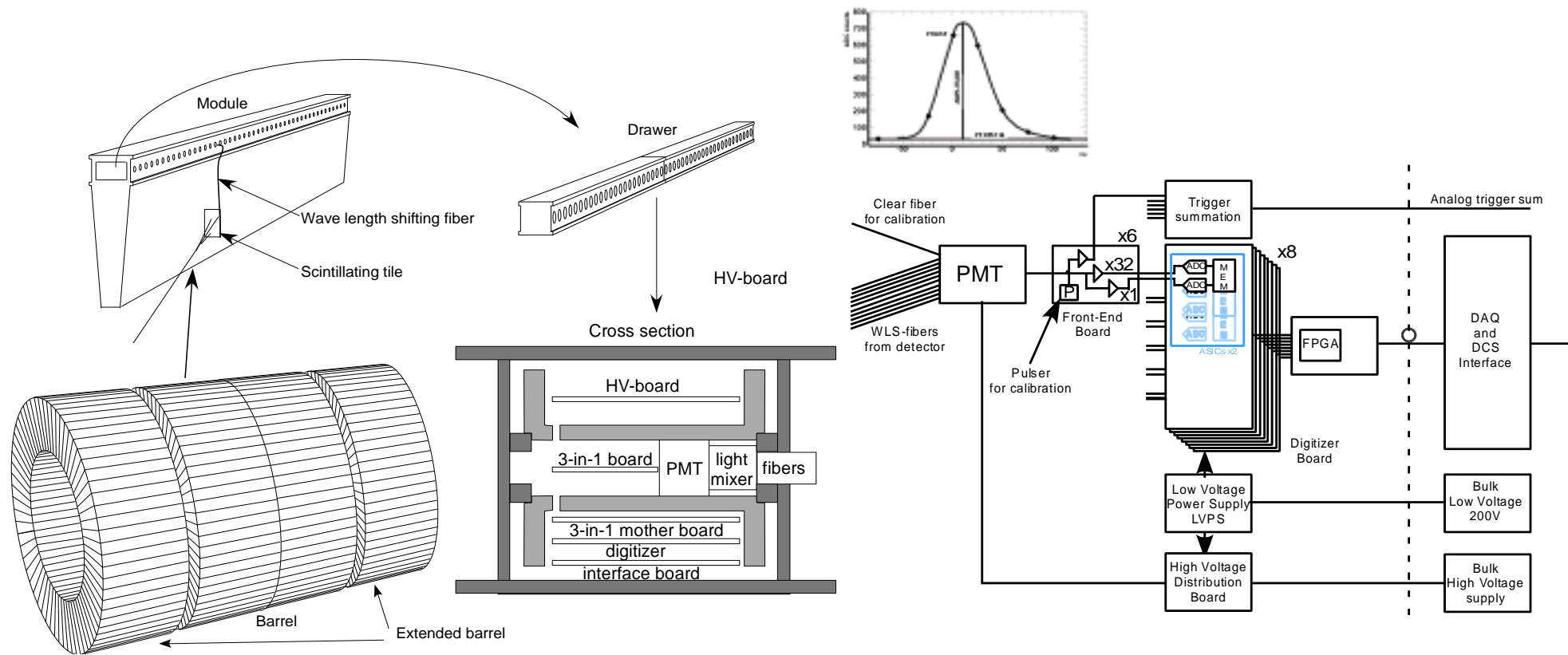

4x64 modules (with electronics in "drawers") with 46 or 32 PMTs each read out by 2 10 bit ADCs (high and low gain)

Each module 8 contains Digitizer boards with 2 ASICs each containing digital pipeline and de-randomizer

Analog trigger signals – digitized in USA-15

Calibration - problem for TileCal

Scintillators and fibers age due to radiation

PMTs age when exposed to light

Three calibration methods:

- Cesium calibration – with circulating sources
- Laser calibration – with clear fibers
- Charge injection – in FEB

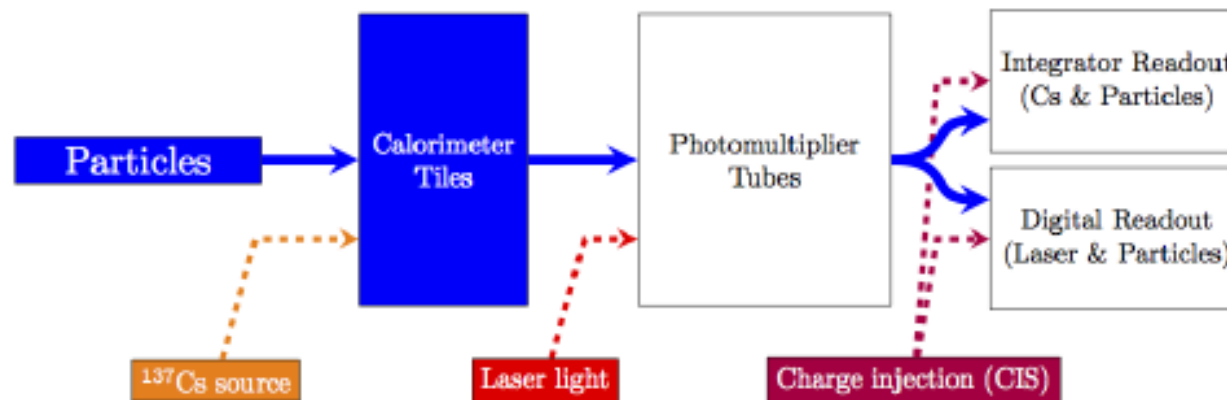
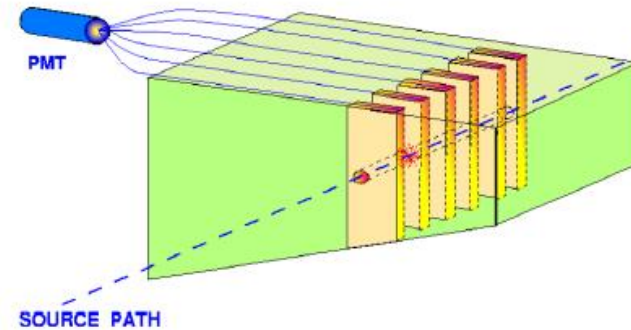

ATLAS upgrades

LHC have regular stops for longer maintenance and upgrade

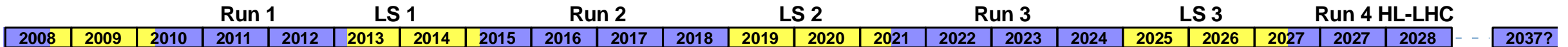

End of operation 2037?

Upgrade phase 0 (LS1)

Prepared for almost full energy 13 TeV

Insertable B-layer – replaced the inner pixel layer

ATLAS upgrades

LHC have regular stops for longer maintenance and upgrade

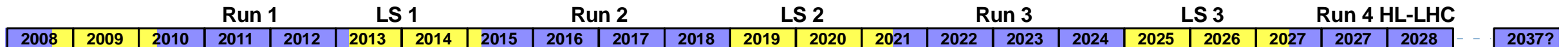

End of operation 2037?

Upgrade phase 1 (LS 2) – 2019-2020

3 times higher luminosity, need better algorithms

Full energy 14 TeV

New Small Wheel? (at least one)

Topological trigger – not only count event but also consider their geometrical relationship

LAr fully digital trigger

New trigger architecture

ATLAS upgrades

LHC have regular stops for longer maintenance and upgrade

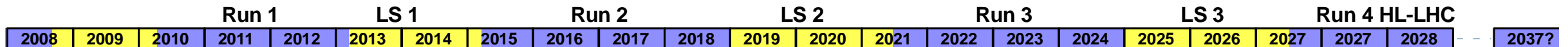

End of operation 2037?

Upgrade phase 2 (LS 3) – 2025-27

Prepare for HL-LHC (High Luminosity LHC)

5 times higher instantaneous luminosity, need still better algorithms

10 times total luminosity – luminosity leveling

New Trigger system – level 0 (L0a: 1MHz, Latency: 6 μ s) (level1 (L1a:<400kHz, Latency: <30 μ s))?

New inner detector – no TRT, track trigger (introducing track data into Level 1)?

New TileCal electronics – read out all data to USA-15 – fully digital trigger

New trigger architecture L0/L1?, higher rates, longer latencies

Track trigger?

Phase 2 (LS3) upgraded TileCal electronics

More luminosity → upto 200 event/bunch crossing → more complex trigger processes → require more data → read out all data directly to off detector trigger
→ Many (4000) 9.6 Gbs links and large FPGAs

New TileCal electronics

Better redundancy, smaller units (failure less costly)

New Low Voltage Power Supplies (partly from South Africa)

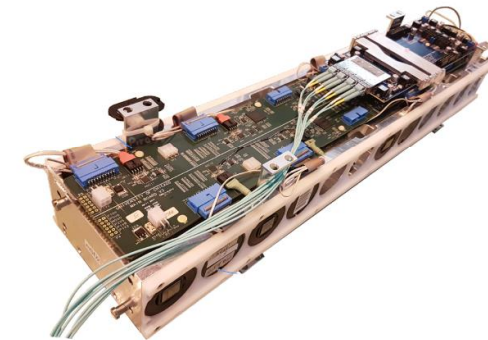
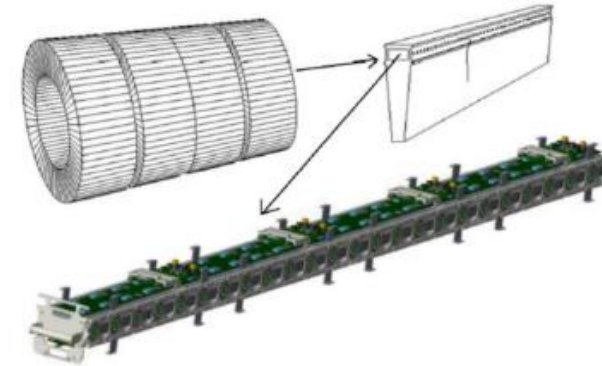

Different electronic design strategies

When designing the first (present) version of the ATLAS electronics then:

- Special rad hard (tolerant) electronics was available (close to end of cold war)

- High speed data transmission (optical or electrical) expensive →

Send trigger data to external trigger processor. Keep data on detector until accepted by L1 trigger – reduced data flow

Now:

- standard electronics reasonably radiation tolerant – SEE problem

- High speed transmission available →

Remove all data from detector as soon as possible

Then:

- FPGAs unsafe

Now:

- SEE mitigation techniques exist making on-detector FPGAs feasible

Mistakes

We learn from mistakes but some times we forget what we learned'

Connector problems

Power supply problems

Radiation sensitivity problems

Problems with new untested techniques

Future

General trends

Higher energies

Higher luminosity

Higher granularity in all detector sub-systems

More complicated events to process early in the triggers

More on-detector FPGAs – new FPGAs more radiation tolerant to hard but not soft errors – develop correction strategies for soft errors

More high speed data transmission – 40 Gb/s or more

Early digitization – less analog, more digital

After 2037? ILC? CLIC? FCC?



Future Circular Collider
FCC

50+50TeV p – p

100 km circumference

Assumes new magnet technologies
(20 TeV magnets)

BUT THIS IS FOR YOU!

TileCal hadron calorimeter

The End
Thanks for your attention