

Trigger-DAQ and Slow Controls Systems in the Mu2e Experiment

A. Gioiosa,¹ G. Horton-Smith,² G. Pezzullo,³ E. Flumerfelt,⁴ V. O'Dell,⁴ L. Uplegger,⁴ and R. A. Rivera⁴

¹INFN Sezione di Pisa; Università di Pisa, I-56127 Pisa, Italy, ²Department of Physics, Kansas State University, Manhattan, Kansas 66506, USA

³Yale University, New Haven, Connecticut, 06520, USA, ⁴Fermi National Accelerator Laboratory, Batavia, Illinois 60510, USA

The Mu2e's Trigger and Data Acquisition System (TDAQ)

needs to satisfy the following requirements:

1. Provide efficiency better than 90% for the signals;
2. Keep the trigger rate below a few kHz - equivalent to ~ 7 PB/year;
3. Achieve a processing time < 5 ms/event.

The TDAQ uses *otsdaq* as its solution. Developed at Fermilab, it uses *artdaq* and *art* software as event filtering and processing frameworks respectively. *otsdaq* supports user defined front-end interface and data processing plugins, and integrates and manages them with a coherent multi-user web interface.

For more information, see <https://otsdaq.fnal.gov>

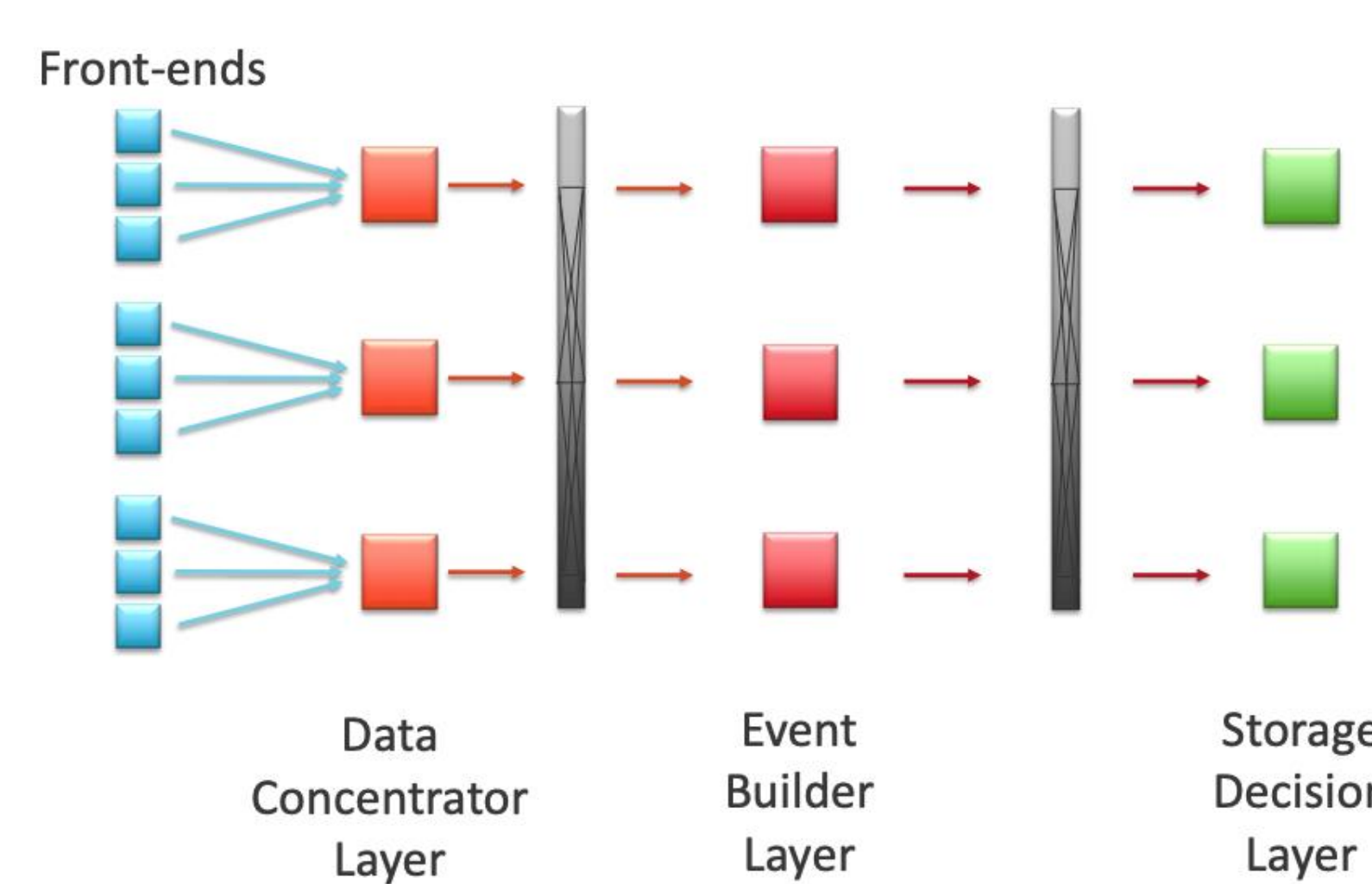
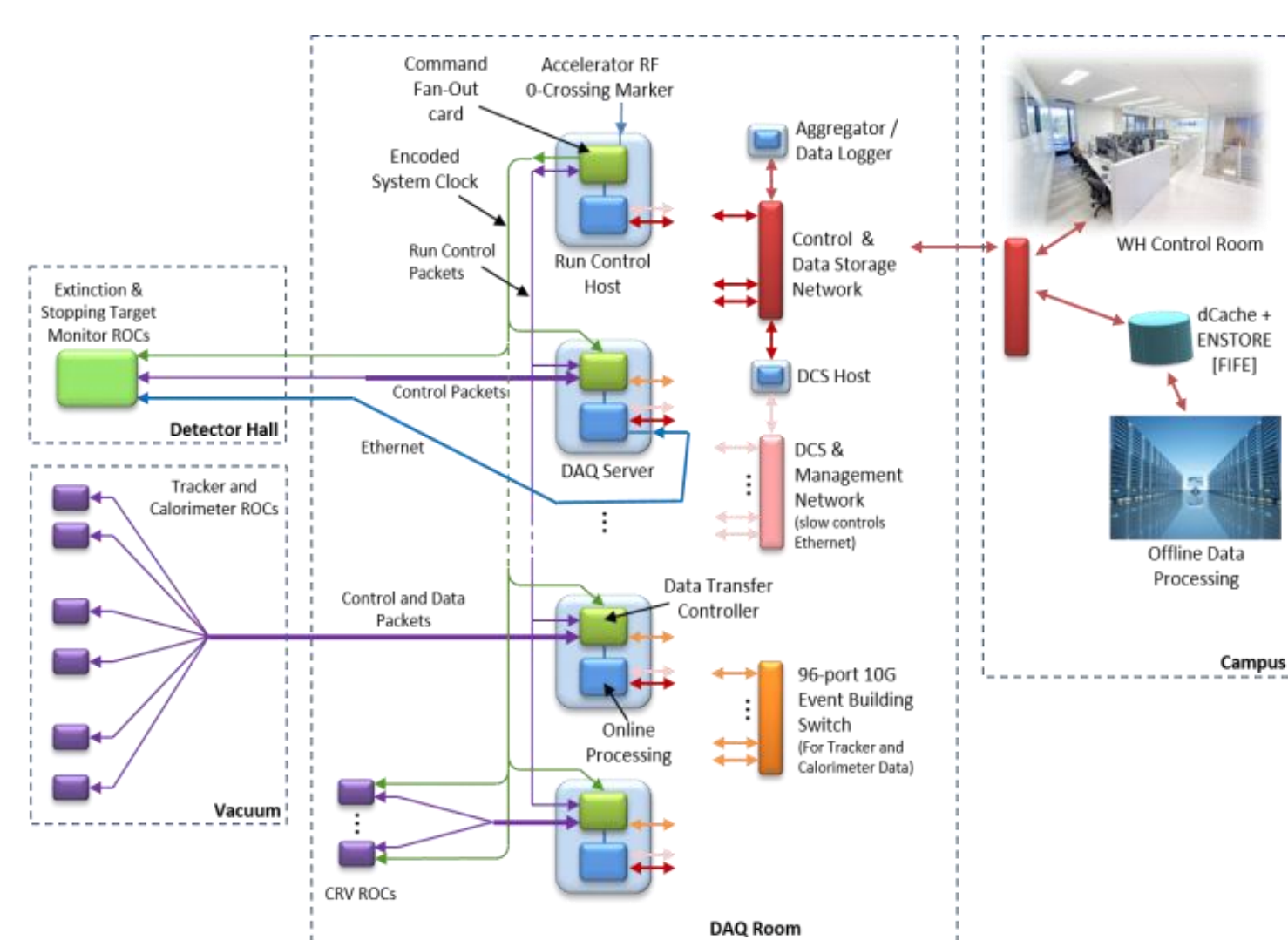

The Mu2e main physics triggers use the info of the reconstructed tracks to make the final decision. The Mu2e Online track reconstruction is factorized into three main steps:

- i Hits preparation, where the digitized signals from the sub-detectors are converted into reconstructed hits;
- ii Pattern-recognition to identify the group of hits that form helicoidal trajectories;
- iii Track fit through the hit wires, which performs a more accurate reconstruction of the track.

A custom front-end interface plugin communicates with the detector Read Out Controller (ROC) firmware of the tracker and calorimeter through the Data Transfer Controller (DTC). ROCs stream out continuously the data, zero-suppressed, to the DTCs. The data of a given event is then grouped in a single server using a 10 GBytes switch. Then, the online reconstruction of the events starts and make a trigger decision. If an event gets triggered, we pull also the data from the CRV and we aggregate them in a single data stream.

The Detector Control System (DCS)

is the window, for experimenters and detector experts, on the status and health of the Mu2e detector. DCS must archive and present graphical user interfaces of both detailed and high-level displays of power supplies, liquid and gas system's operational data, environmental temperatures and magnetic field strength, and status and run condition information for the data acquisition of every portion of the detector.

EPICS Experimental Physics and Industrial Control System (EPICS) has been chosen for DCS implementation. It is open source, originally developed at Argonne, and at Fermilab, has most recently been implemented in many experiments.

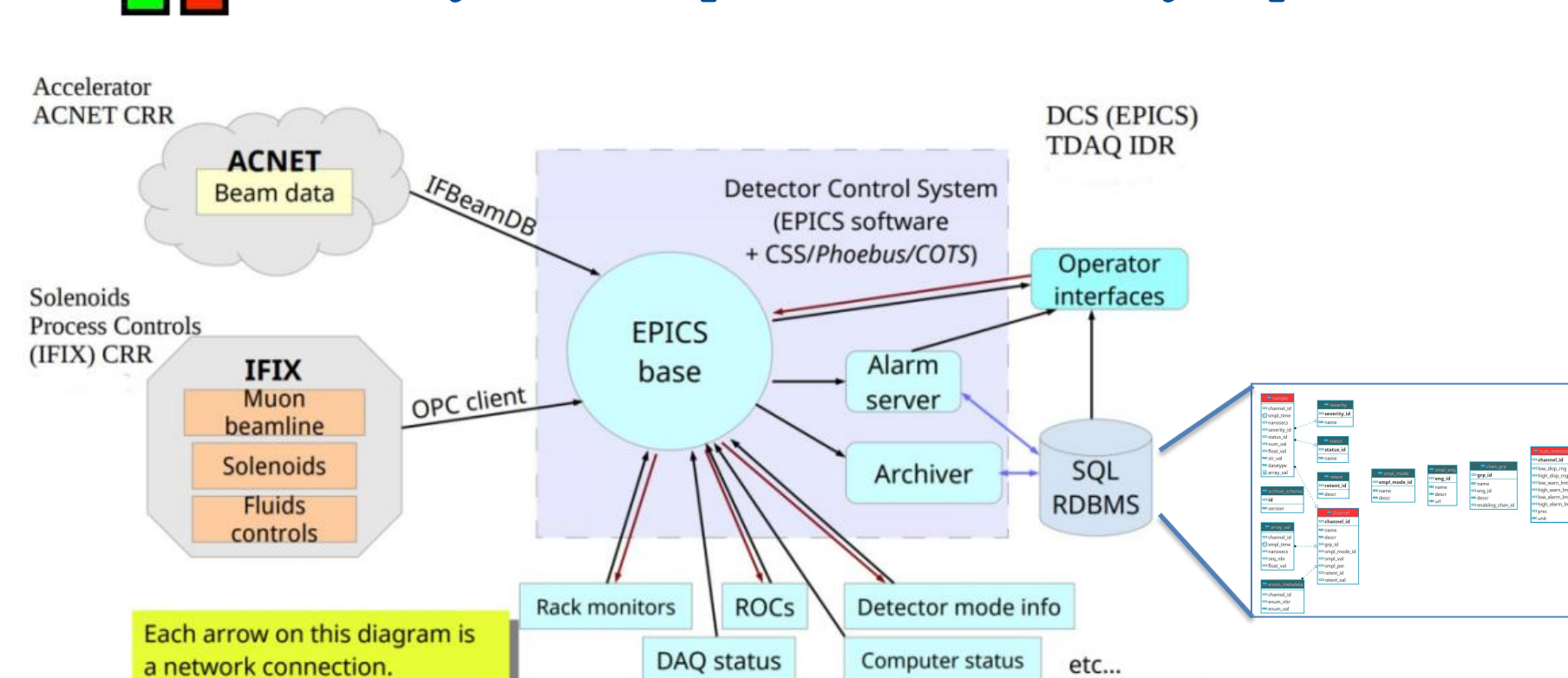

The DCS supplies Ethernet networking and Ethernet-based controllers for general control and monitoring of power supplies, beamline equipment, and environmental sensors. It also provides generic analog and digital I/O endpoints. Other application-specific endpoints are provided by the corresponding subsystems. The DCS does not interface to safety-related controls or monitors for purposes other than secondary interlock (permit) and status logging.

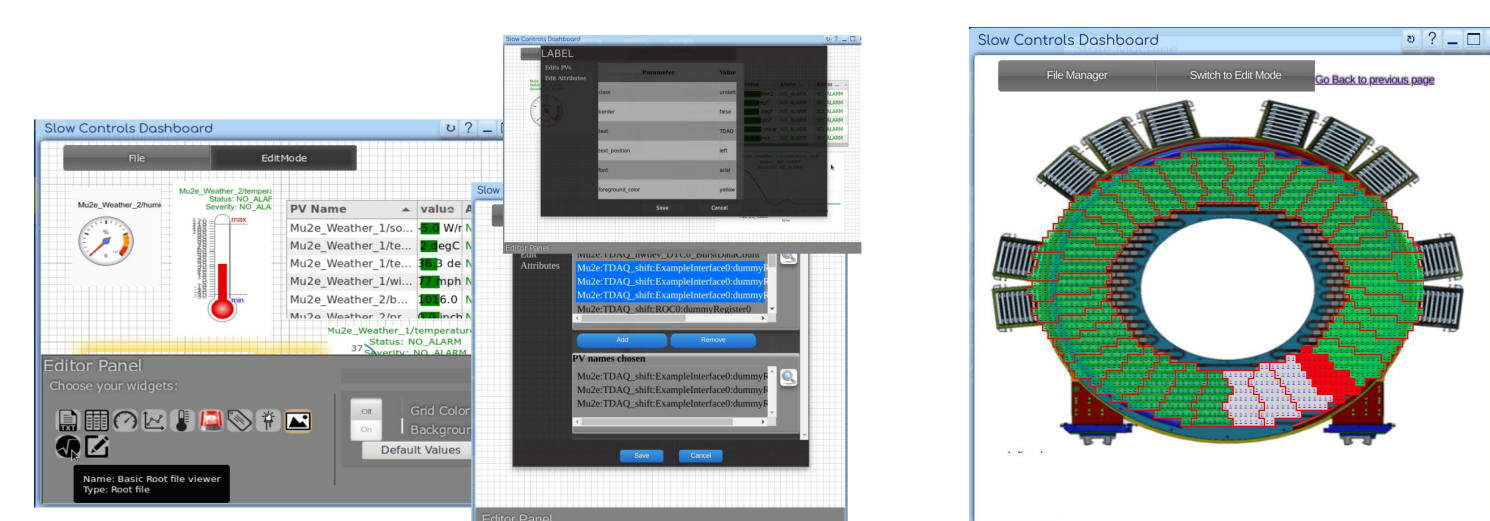

A DCS web GUI has been developed, fully integrated into *otsdaq*. It includes a slow controls dashboard that has the following features: a searchable library of widgets, template widgets for customization, quick-snap pages for easy viewing, UI Scalability for high pixel screens or TVs, variable polling rates, Drag n' Drop widgets, snap grid, infinite UI color customization, simple notes and names incorporated into the settings of each widget, page saving and loading. It also includes configurable system message alarm notifications that use web and mail services to broadcast alerts to users.

The muon campus program at Fermilab includes the Mu2e experiment that will search for a charged-lepton flavor violating processes where a negative muon converts into an electron in the field of an aluminum nucleus, improving by four orders of magnitude the search sensitivity reached so far.

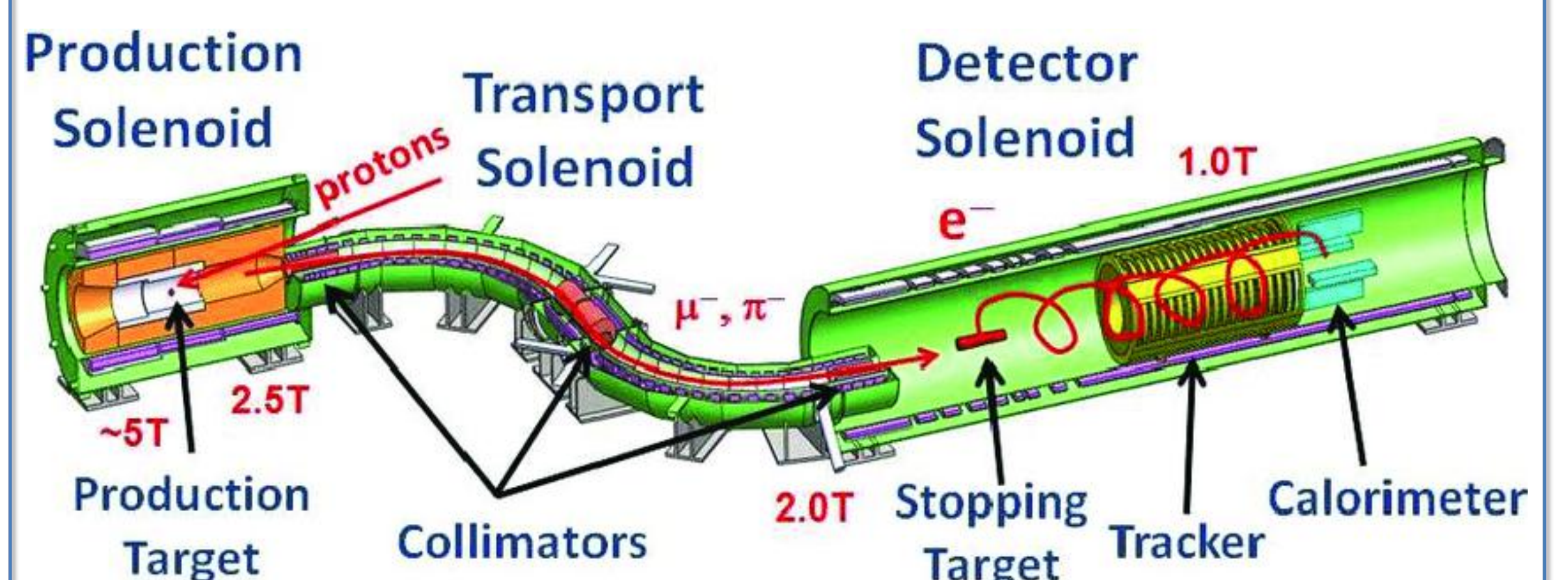

The Mu2e apparatus includes three superconducting solenoids: (1) the production solenoid, where an 8 GeV proton pulsed-beam (period $\sim 1.7 \mu\text{s}$) hits a tungsten target, producing mostly pions; (2) the transport solenoid, which serves as a decay "tunnel" for the pions, and makes also charge and momentum selection, creating a low-momentum μ^- beam; (3) the detector solenoid, which houses an aluminum Stopping Target, where the muons get stopped and form muonic atoms, and the detector system (a 3.2 m long straw tube tracker and a crystal calorimeter in a 1T solenoidal magnetic field) optimized to detect electrons and positrons from the muon conversions.

otsdaq system includes a part of DCS that communicates with EPICS. Each ROC also has a microcontroller, which handles DCS "slow control" operations and is responsible for initializing the FPGA. The microcontroller is integrated into the FPGA. DCS commands can then be used to remotely load new software/firmware into the application program memory.

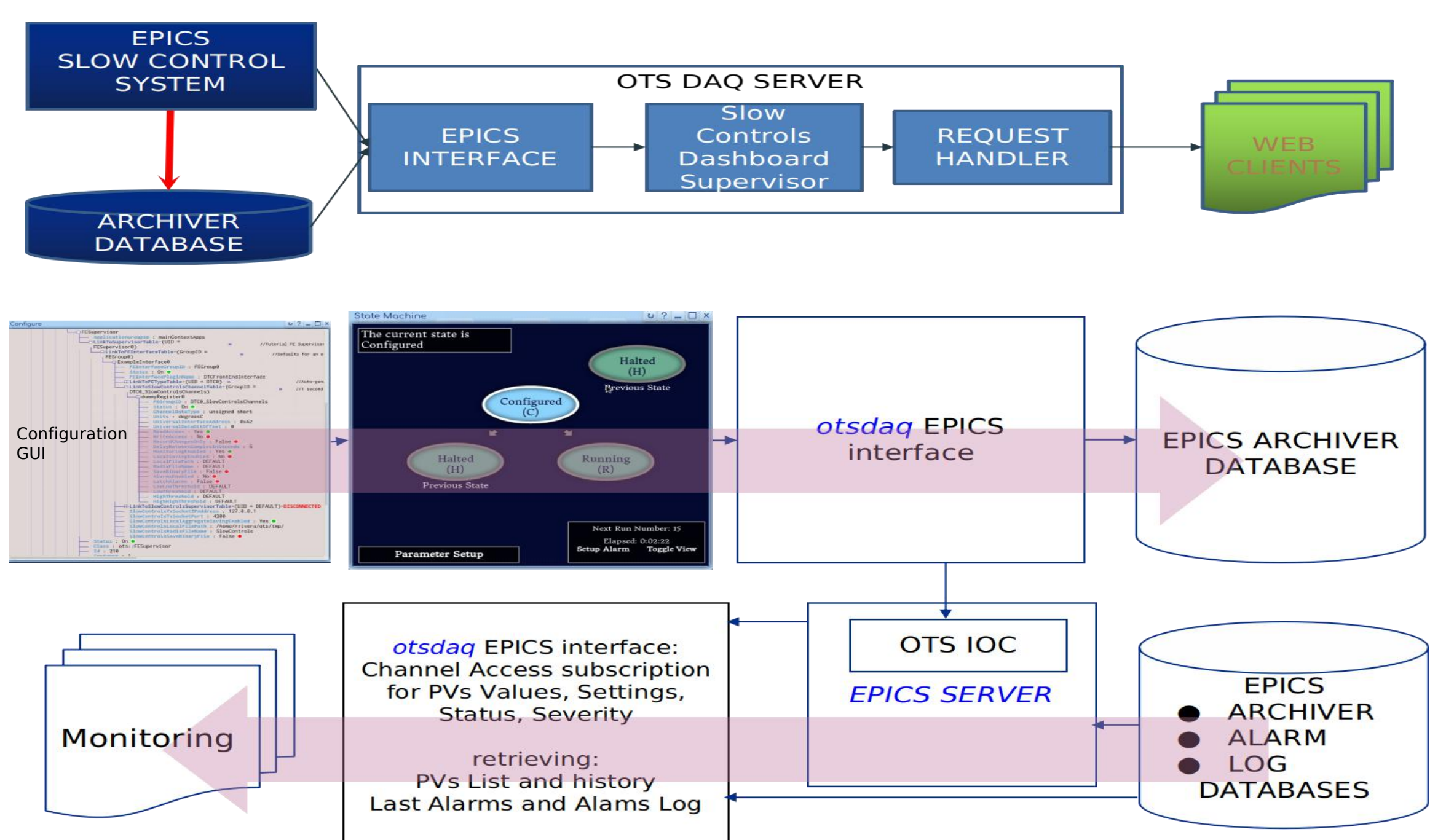

otsdaq allows the user to monitor or interact with their own DAQ hardware and all other devices managed by EPICS:

1. Observe Process Variables (PVs) informations such as settings, alarms, warnings, readouts, timestamps, status;
2. Interact through a web interface that is lightweight, user-Friendly, plug n' play, customizable;
3. Implement custom handling of PV alarms integrated with the TDAQ state machine transitions.

