



Readout Method for GAEA Gamma Spectrometer at CSNS Back-n White Neutron Source

Likun Xie^{1,2}, Ping Cao^{1,2}, Xinyi Tang^{1,2}, Tao Yu^{1,2}, Chao Li^{1,2}, Xiru Huang^{1,2}, Zhijie Jiang^{1,2}, Qi An^{1,2}

1. State Key Laboratory of Particle Detection and Electronics, University of Science and Technology of China, Hefei 230026, China

2. Department of Modern Physics, University of Science and Technology of China, Hefei 230026, China

*Corresponding author: cping@ustc.edu.cn



Likun Xie

I. Introduction

Back-n is a white neutron beam line at China Spallation Neutron Source (CSNS). At Back-n, GAEA (gamma spectrometer with germanium array) spectrometer is planned for measurements of neutron-induced cross-sections, which involves detecting the gamma rays emitted following inelastic scattering, (n, 2n γ) and (n, 3n γ) reactions. As shown in Fig.1, The spectrometer mainly consists of 50 large volume HPGe detectors, 10 HPGe clover detectors and 10 planar-type HPGe detectors, forming a 4 π detector array. Besides, BGO crystals are used for Compton suppression, while 20 LaBr₃ (Ce) detectors and 3 Si (Li) detectors are employed for auxiliary detection.

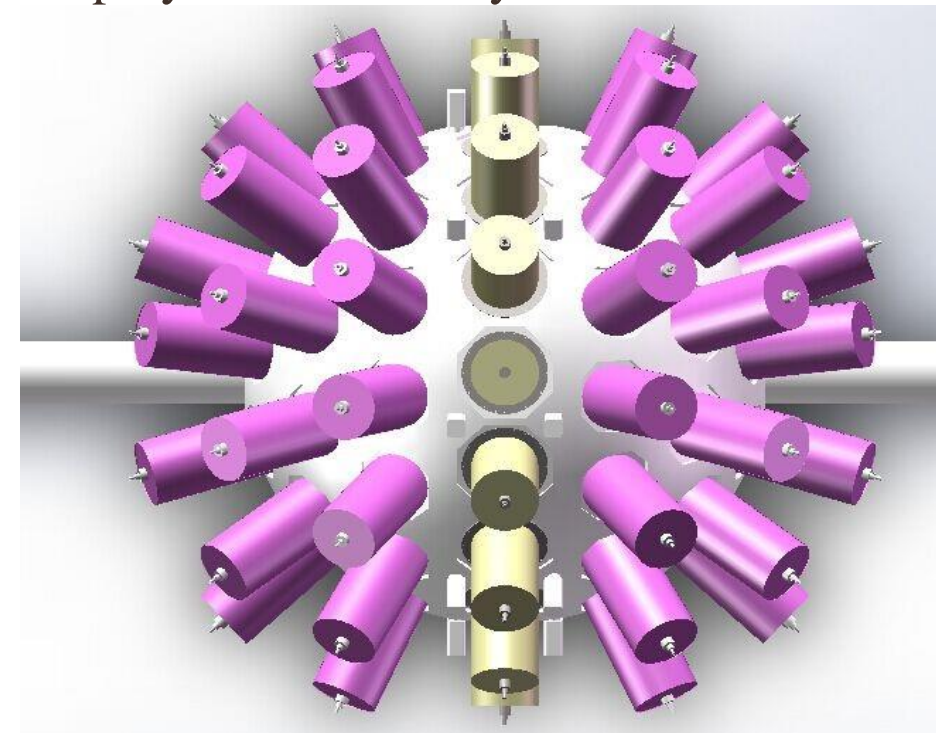

Fig.1. Structure diagram of GAEA spectrometer

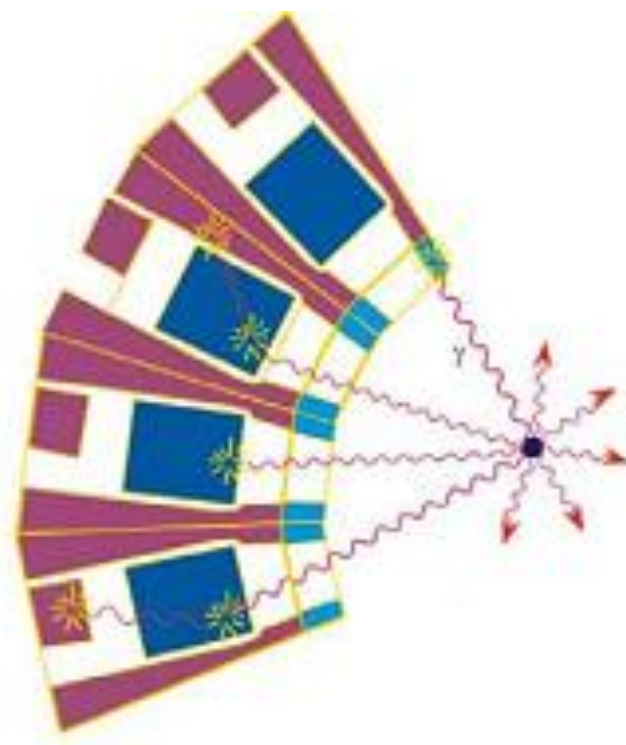

Fig.2. Design of Compton suppression

As the output signal features vary from detector types, the structure of electronics will be so complicated if the conventional readout method is used. Besides, the large number of signal channels also require the system to be concise. The development of high-speed and high-precision ADC makes waveform digitization a better choice for GAEA. The signals will be digitalized directly after amplitude conditioning, which makes the signal difference no longer obvious. Therefore, a readout method to precisely digitize and read out data from the GAEA spectrometer is proposed in this paper.

II. Implement of Universal Readout Method

The readout electronics has a distributed architecture based on PXIe crates, as illustrated in Fig.3. It mainly consists of the signal digitization module (SDM), the trigger and clock module (TCM) and data transmission network.

As the energy resolution of HPGe detectors is better than 2keV at 1.33MeV, the corresponding effective number of bits (ENOB) of ADC should be better than 10.97 bits. Due to the 8–10 ns leading edge time for the output signal of LaBr₃ detector, it is better to set the sampling interval time to be 2 ns to capture the waveform precisely. Finally, two quad-channel ADC with high speed (500 MSPS) and high resolution (14 bits) are employed in the SDM to improve the integration.

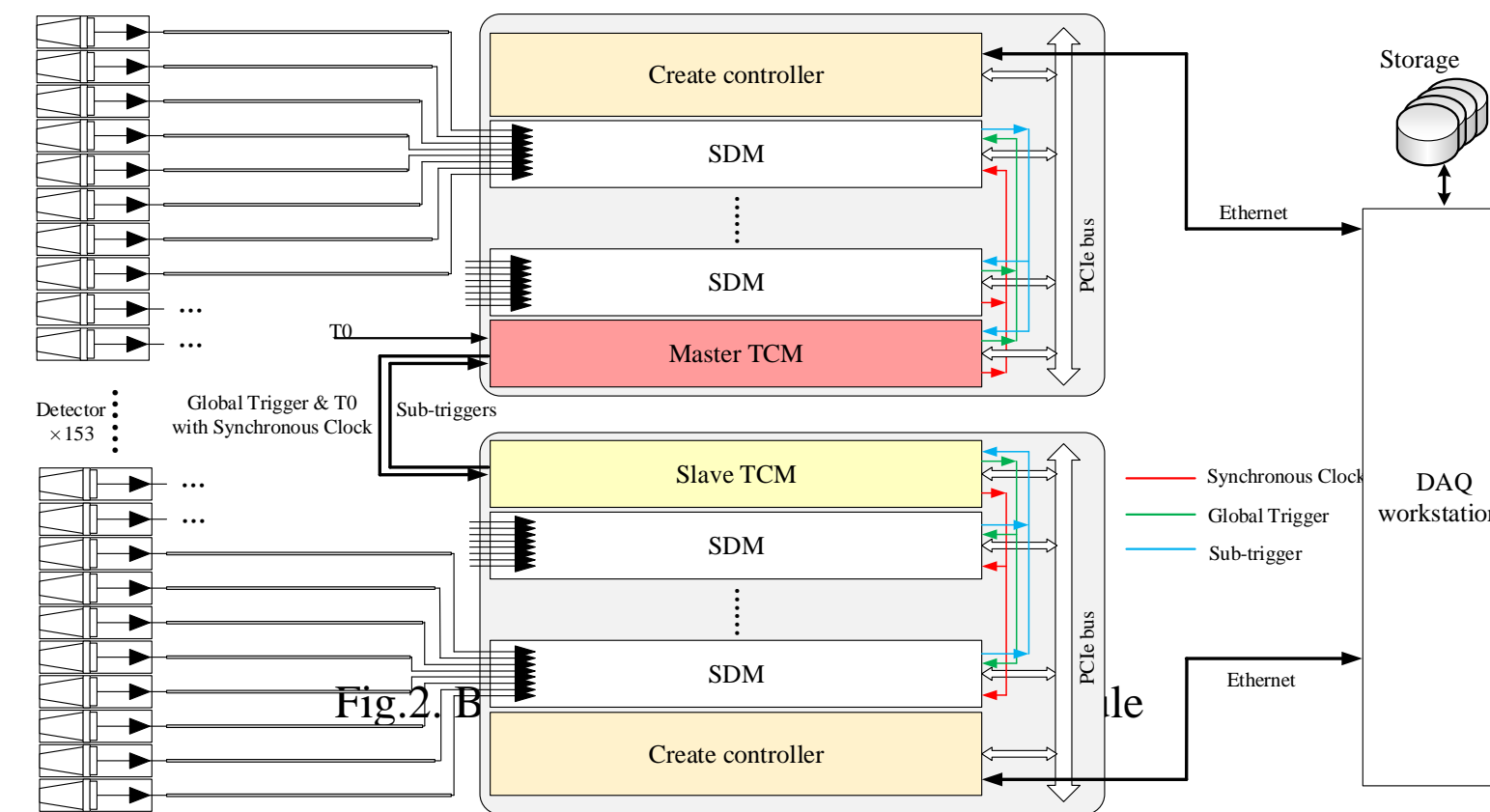

Fig.3. Architecture of distributed readout electronics system.

A high-bandwidth PCIe bus and distributed structure with two PXIe crates are introduced into the readout electronics. The TCM is designed to construct a high-precision synchronous clock and trigger network for all SDMs. There are master TCM and slave TCM, which work in the master and the slave chassis respectively. Located at the system timing slot, the TCM can interconnect with SDMs in the same chassis through the differential star buses in the PXIe backplane. Meanwhile, the master and the slave TCM use the GTP channels in the front panel to communicate with each other.

III. The Signal Digitization Module

As illustrated in Fig.4, the SDM contains a dedicated mezzanine card and a universal carrier card. Each SDM is composed of analog signal conditioning circuit, ADC, clock circuit, FPGA, Double Data Rate (DDR4) memories and PXIe readout interface. In the mezzanine card, the input signal is digitized directly by ADC after passing a dedicated analog conditioning circuit. A JESD204B serial interface is used in ADC to transmit data to the FPGA in the carrier card. To transmit massive data in real time, SDM is integrated with PXIe interface based on FPGA.

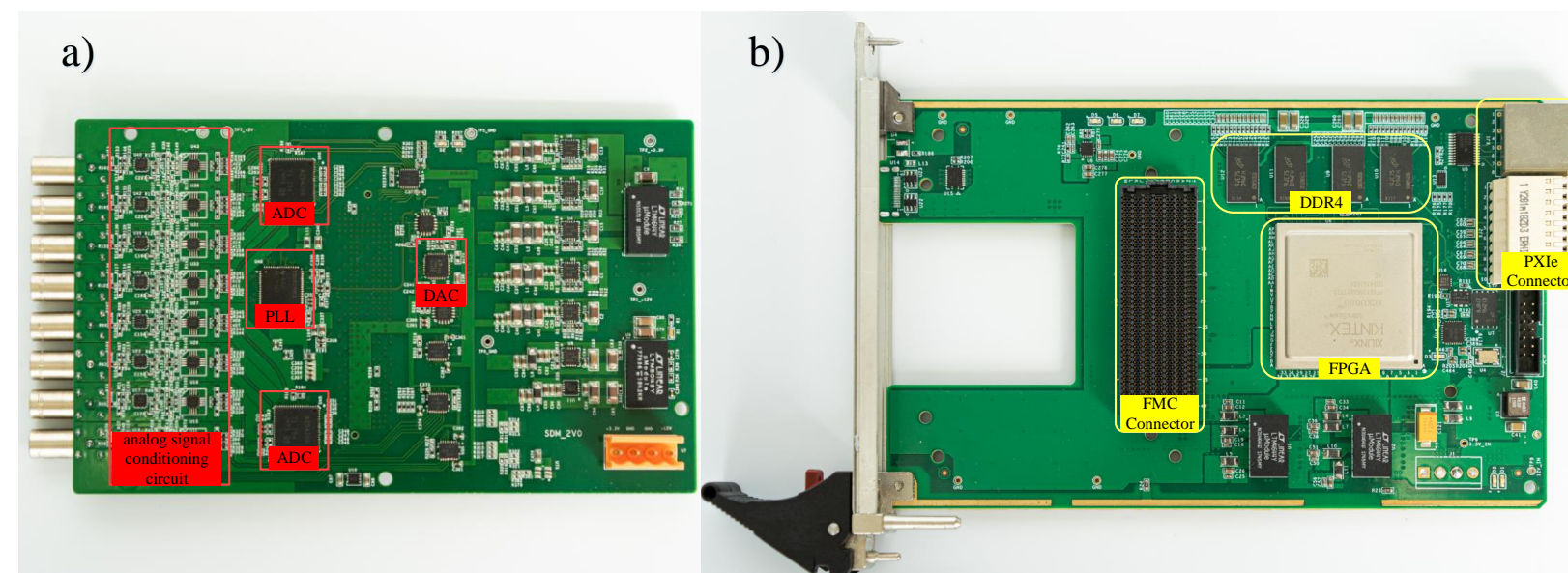

Fig. 4. The photograph of SDM (a) and GDM (b)

IV. Evaluation and Verification

The gain and bandwidth of analog conditioning circuit for various detectors are different. The analog conditioning circuit for the HPGe detector needs a large gain and small bandwidth (<5 MHz). As illustrated in Fig.5, its bandwidth is limited in 24 MHz to suppress the high-frequency noise. In the same way, the -3 dB bandwidth of the analog conditioning circuit for LaBr₃ detectors is about 70 MHz. To evaluate the dynamic performances of the ADCs, sine waves with different frequencies were fed into the SDM after narrowband filtering. FFT (Fast Fourier transform) was used for the analysis of ADC dynamic performance. Test results show that the ENOBs of SDM for the HPGe detectors are larger than 11 bit in the whole range of 20 MHz. As for the LaBr₃ detector, the ENOBs are larger than 10.1 bit in the whole range of 50 MHz.

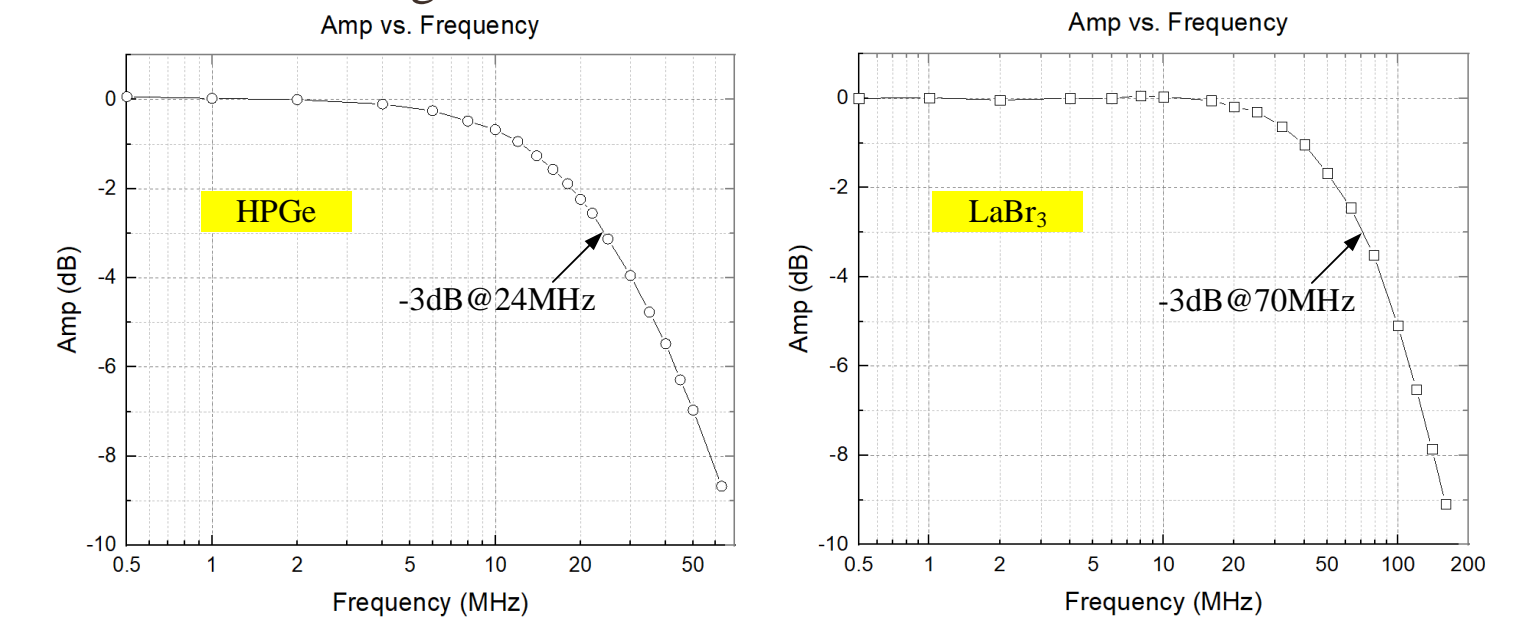

Fig.5. Test result of analog conditioning circuit

V. Conclusion

A new readout method for the GAEA Spectrometer at Back-n is proposed in this paper. The readout electronics adopts waveform digitizing method with 500 MSPS sampling rate and 14-bit resolution to precisely acquire the signal's waveform. The distributed structure with PXIe platform not only solves the problem of massive data transmission, but also provides excellent backplane buses for clock distribution and trigger information exchange. By separating the waveform digitizer into a dedicated mezzanine card and a universal carrier card, the adaptation to different detectors is achieved. Besides high integration, the architecture has the advantages of low design risk, good flexibility, and expansibility. Test results show that the ADC performance, and other key performance fully meet the requirements of the GAEA spectrometer.

Acknowledgement

This work is supported by National Key Research and Development Project of China (No. 2016YFA0401602) and Anhui Provincial Natural Science Foundation for Distinguished Young Scholars (1808085J22).