



*PICMG Specifications for Advanced Research Projects
- A Brief History in Time*

IEEE Real Time Conference

June 9, 2018

Heiko Koerte on behalf of Justin Moll (VP Marketing PICMG)

Topics



- Introduction to PICMG
- MicroTCA/MicroTCA.4 in Physics
- MicroTCA – Versatility in Applications
- 40G MicroTCA Efforts
- Resources – Application Guides, Links to Content
- PICMG – What's Next

PICMG is the leading specification development organization in the embedded industry.

- Over 150 member companies, relatively evenly distributed between America, Europe, and Asia
- Main (current) specifications are AdvancedTCA, MicroTCA/AMC, COM Express, CompactPCI, CompactPCI Serial and CompactPCI Serial Space, HPM, and SHB (PICMG 1.3)
- Wide range of markets and specification types

MicroTCA™

PICMG® MTCA.0 R1.0

Micro Telecommunications Computing Architecture Short Form Specification

September 21st, 2006

This short form specification is derived from the PICMG® MTCA.0 Micro Telecommunications Computing Architecture (MicroTCA.0) specification.

For guidelines on the design of the MicroTCA™ compliant modules and systems, refer to the full specification. Do not use this short form specification for any design decisions.

Not Intended for Design - Do not Claim Compliance



Short Form created by Stuart Jamieson of Emerson Network Power, Embedded Computing

Copyright 2006, PICMG

MicroTCA and the μ TCA are trademarks of PICMG.
AdvancedTCA and AdvancedMC are registered trademarks of PICMG.

Open Specification vs. Open Source

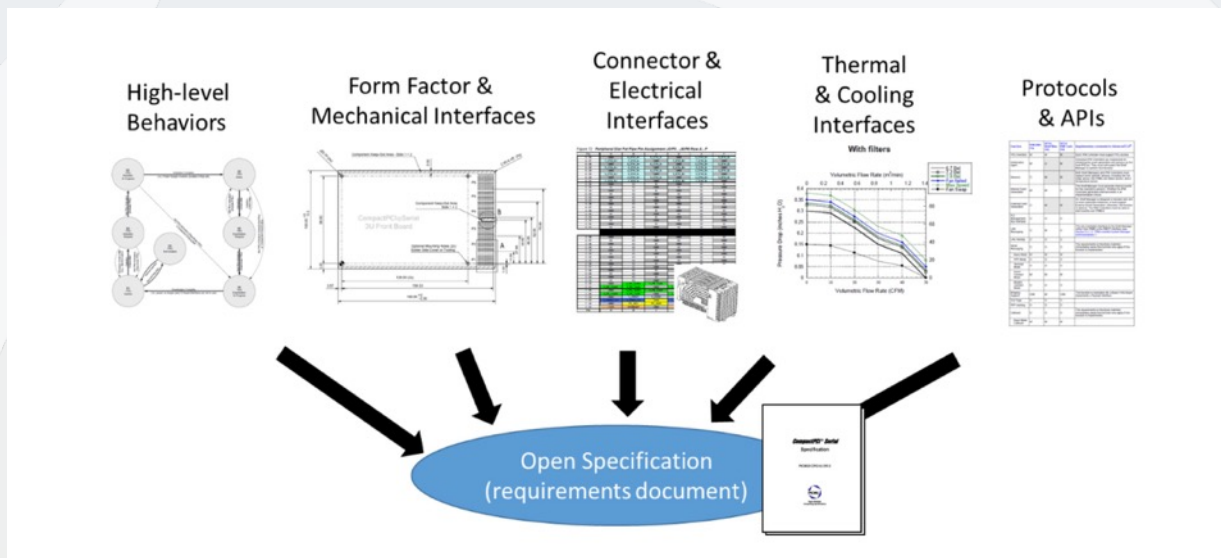
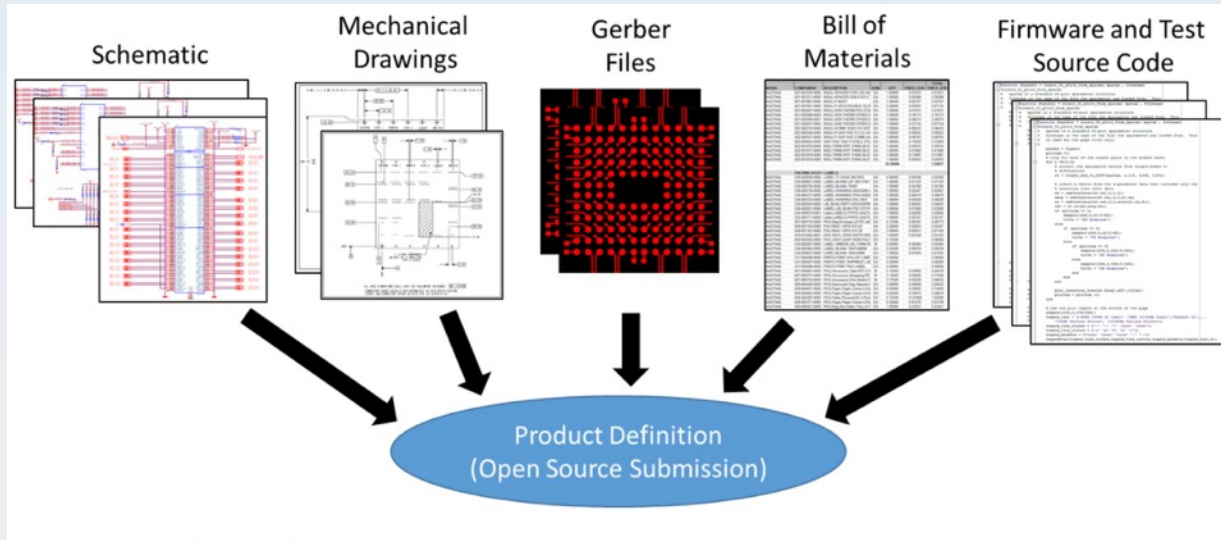

Introducing New Specs

- By-laws require 3 members companies to sponsor
- Often individual companies bringing spec concepts – opened up to larger community to improve/modify
- Fast track, but no rubber stamp
- IPR Policy, levels of participation
- Review process

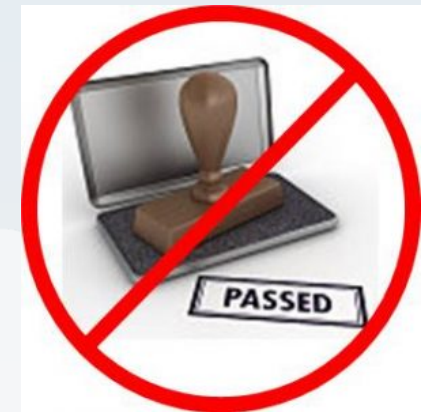

A Variety of Specifications & Core Markets



- Various types – backplane-based hardware, motherboard-based hardware, mezzanine COM-based hardware, and system management software

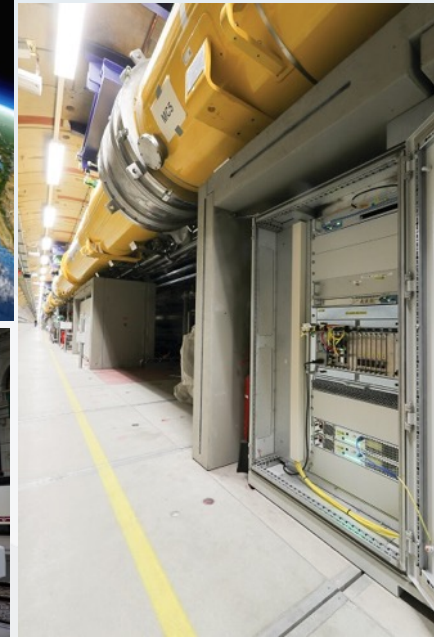

Copyright Dirk Noelle

Industries



Markets

Our diverse membership allows PICMG to develop compelling specifications in multiple markets. PICMG technologies are widely used in a broad swath of industries including industrial automation, military/aerospace, transportation, communications, test/measurement, physics/research, energy, medical, and more!

	COM Express	AdvancedTCA	CompactPCI	CompactPCI Serial	HPM	MicroTCA / AMC	SHB
Industrial Automation	X		X	X		X	X
Gaming	X						
Telecommunications	X	X			X	X	
Aerospace	X		X	X	X	X	
Defense	X	X	X	X	X	X	X
Railway	X		X	X	X	X	
Energy	X		X	X	X	X	X
Medical	X		X	X	X	X	
Test / Measurement	X	X	X	X	X	X	
Physics		X			X	X	X
Drones / UAV	X		X	X	X	X	

MicroTCA/MicroTCA.4 in Physics



MicroTCA has advantages for High Energy Physics (HEP) and many other markets

- PCIe Gen3 and 40GbE capable
- Superior SWaP (Size, Weight, Power)
- Inherent reliability (6 nines uptime)
- Multiple clock options with MicroTCA.4 special timing provisions
- Rear I/O capable with MicroTCA.4

Applications include:

- Low Level RF (LLRF) control
- Beam Position Monitors (BPM)
- Beam Loss Monitors (BLM)
- Local Protection System of the Radio-Frequency sources (RF-LPS)



Applications



PICMG does not have official numbers on MicroTCA size, but members have shared the following:

- Continuing growth in Mil/Aero applications. Mostly MTCA.0, MTCA.1, and purpose-built conduction-cooled
- Large Physics presence, other Research Labs
- Applications where no other architecture can provide the performance and SWaP advantages
- Applications stretch from Banking, Automation, Defense, Satellites, Communications/Test, Physics, Advanced Research Labs, Railway Communications, and Medical Imaging

Applications Guide - https://www.picmg.org/wp-content/uploads/MicroTCA_Application_Guide_final_rev1_1.pdf

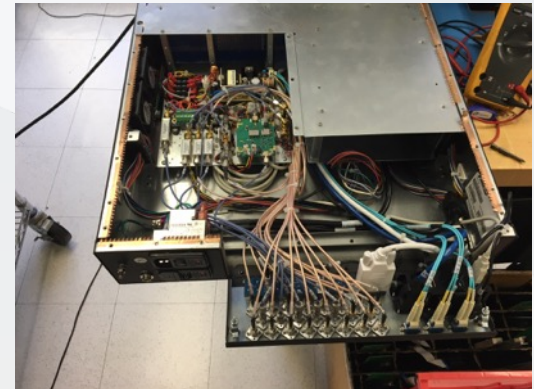

Applications (Con't)

- VoIP Media Gateway - a traditional telco type architecture with dual redundancy with the aim of providing 99.999% availability. Systems consist of processors, storage, networking and telco interfaces
- Mobile basestation - used for trials, test equipment and emergency deployments, architecture typically consists of a CPU linked to DSP and FPGA baseband processing elements.
- Banknote inspection systems - They presented their solution at the 2016 MicroTCA workshop which has a custom backplane with a built in MCH that is split into two systems
- Semiconductor lithography stepper motor control systems - quite possibly the biggest AdvancedMC user with the modules mounted on ATCA carriers including CPU, FPGA and DSP elements all linked using a RapidIO fabric for low latency.
- Telecom Test & Measurement market - It is used inside a cabinet and is a wideband channel RF system with 2x dual channel RF cards used in LTE and LTE advanced test equipment.
- Navy - towed array for submarines
- NASA's Space Network Ground Segment Sustainment Project
- Ground RADAR for Airports, Mobile RADAR



40GbE MicroTCA.0 and AMC.2 Efforts



The Higher Speed Ethernet Fabrics for MicroTCA.0 and AMC.2 group has shown that 40GbE MicroTCA performs within IEEE limits, with some caveats.

- The spec is expected to be completed in 2018. We need to develop multiple AMC and MCH test cards to characterize the simulation results.
- Simulations shows that the press-fit passes under most conditions. The compression-mount passes under all test conditions applied.
- Tips include: Place hub slots in center, Nelco4000-13SI was very effective.

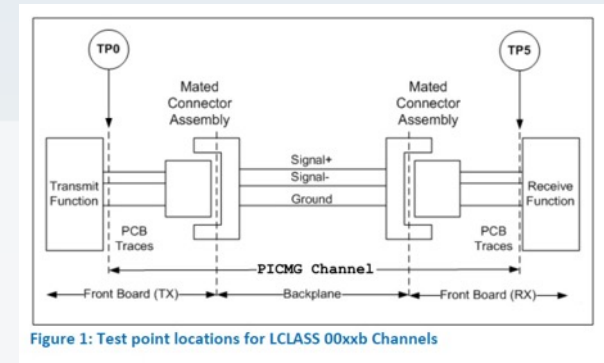

Resources

Design Guides and more on the PICMG Web site:

- Physics Design Guide for Clocks, Gates & Triggers in Instrumentation

https://www.picmg.org/wp-content/uploads/PDG_0-R1_0-RELEASED-2013-04-231.pdf

- Standard process models and APIs

https://www.picmg.org/wp-content/uploads/PICMG_uTCA_DG_3R1_0.pdf

- Standard device models and APIs

https://www.picmg.org/wp-content/uploads/PICMG_uTCA_DG_2R1_0.pdf

- PICMG® MTCA.4 PCI Express Hot Plug Design Guide

https://www.picmg.org/wp-content/uploads/PICMG_MTCA_DG_0-PCI-Express-Hot-Plug_RELEASED-2017-01-09-002-1.pdf

- Standard Hardware API Design Guide

https://www.picmg.org/wp-content/uploads/PICMG_MTCA_DG_1-Standard_Hardware_API_Design_Guide_RELEASED-2017-01-09-002.pdf

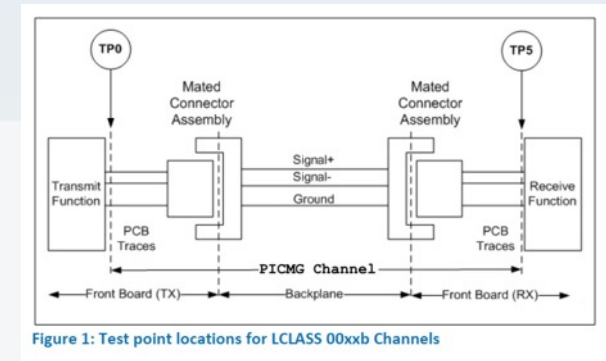

Figure 1: Test point locations for LCLASS 00xxb Channels



PICMG – What’s Next?

IoT is the “next big thing” for PICMG. It is expected that many applications will use COM Express for IoT, but for the aggregators and high-end systems, MicroTCA and CompactPCI Serial in various forms could also be a great fit.

- Interoperable families of specs – small “postage stamp” type of spec to COM Express to MicroTCA.
- Looking for participants



Why Join PICMG?

- Early access to key technology
- Participate in specification development
- Leverage PICMG promotions and marketing efforts
- Develop relationships with thought leaders and suppliers
- Gain visibility and leads from your products and content on the PICMG Web site
- Low-cost membership – Affiliates join for as low as \$1000.00*

- * 2017 price, subject to change

PICMG Marketing Efforts



- New Product Listings on Web site
- Press release
- Case studies, application notes, articles, white papers
- Joint articles in leading publications
- Participate in PICMG events – Embedded World booth, etc.
- Company listings on Web site
- Email blasts, newsletters, social media
- Multiple publications covering PICMG products

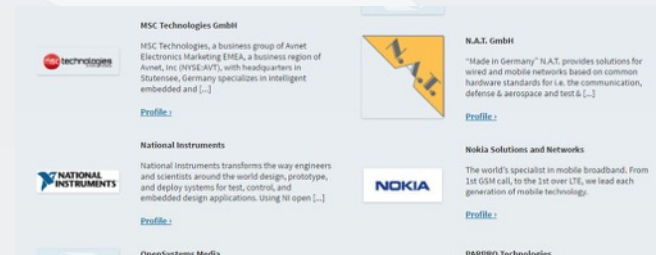
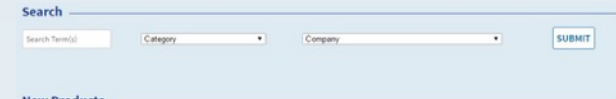

Questions



What would you like to see regarding new MicroTCA efforts? (new short form specs, other Design Guides, PCIe Gen4?)

Other questions?

Thank you!