

Real-Time Betatron Tune Correction with the Precise Measurement of Magnet Current

Yoshinori Kurimoto, Tetsushi Shimogawa and Daichi Naito
High Energy Accelerator Research Organization



Abstract - The betatron tune, which is defined as the number of transverse oscillations in one turn of a ring accelerator, must be precisely controlled by electrode magnets. The ripple of the magnet current directly displaces the betatron tune from its designated value. We have developed a system that corrects the betatron tune displacement using the measured magnet current at the J-PARC (Japan Proton Accelerator Research Complex) Main Ring. We adopted Field Programmable Gated Arrays (FPGA) to convert from the measured magnet current to the betatron tune in real time. Using the system, we have decreased the fluctuation of the betatron tune by approximately 43 % at the frequencies less than 250 Hz.

Introduction

Betatron Oscillation $x(s) = \sqrt{\epsilon\beta(s)} \cos(\varphi(s) + \varphi_0)$

Focusing and de-focusing magnets are alternatively placed along the ring so that the transverse motion can be controlled

Betatron Tune $\nu_{x(y)}$

The number of the oscillation in one turn

$$\nu_{x(y)} = \frac{1}{2\pi} \oint \varphi(s) ds$$

Resonance Condition of $\nu_{x(y)}$

Ex. $\nu_x = \text{integer}$

$m\nu_x + n\nu_y = l$
(m, n, l : integer)
must be avoid

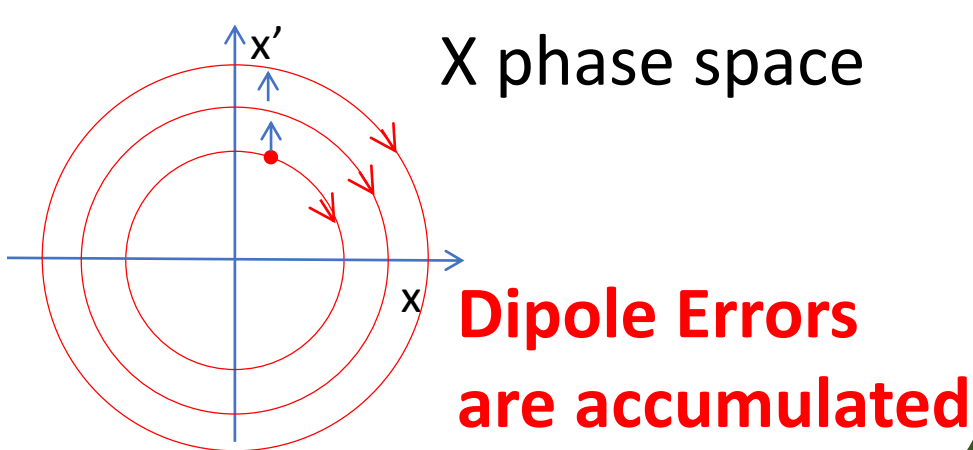

How to control the $\nu_{x(y)}$

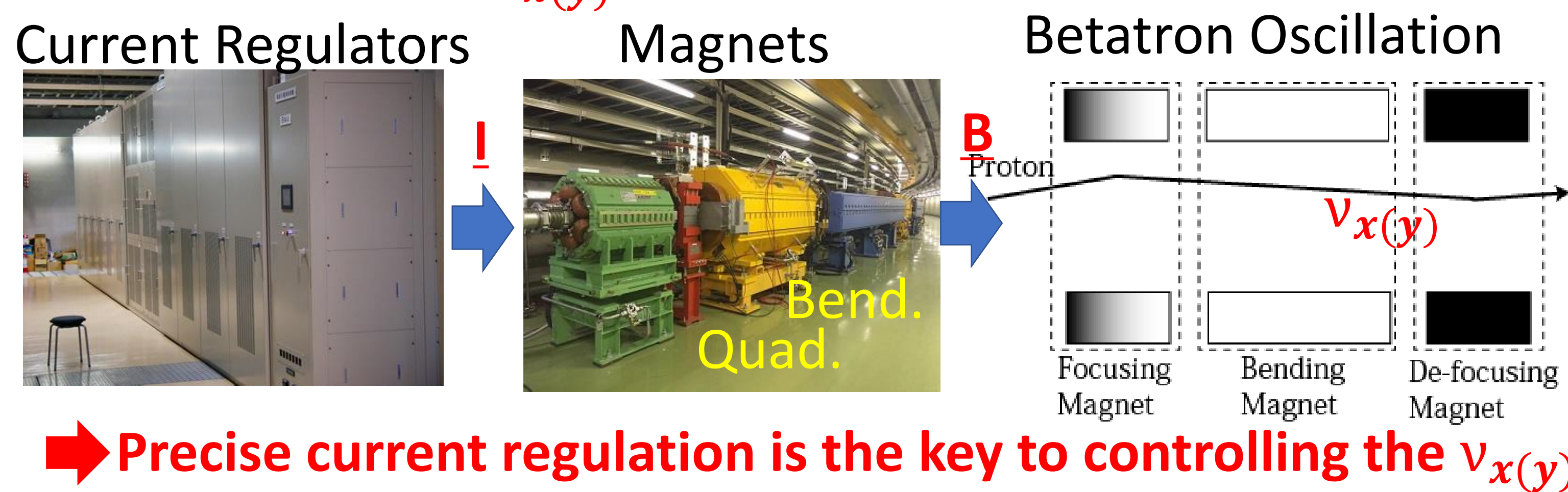

Real-Time ν Correction with Magnet Current

Motivation

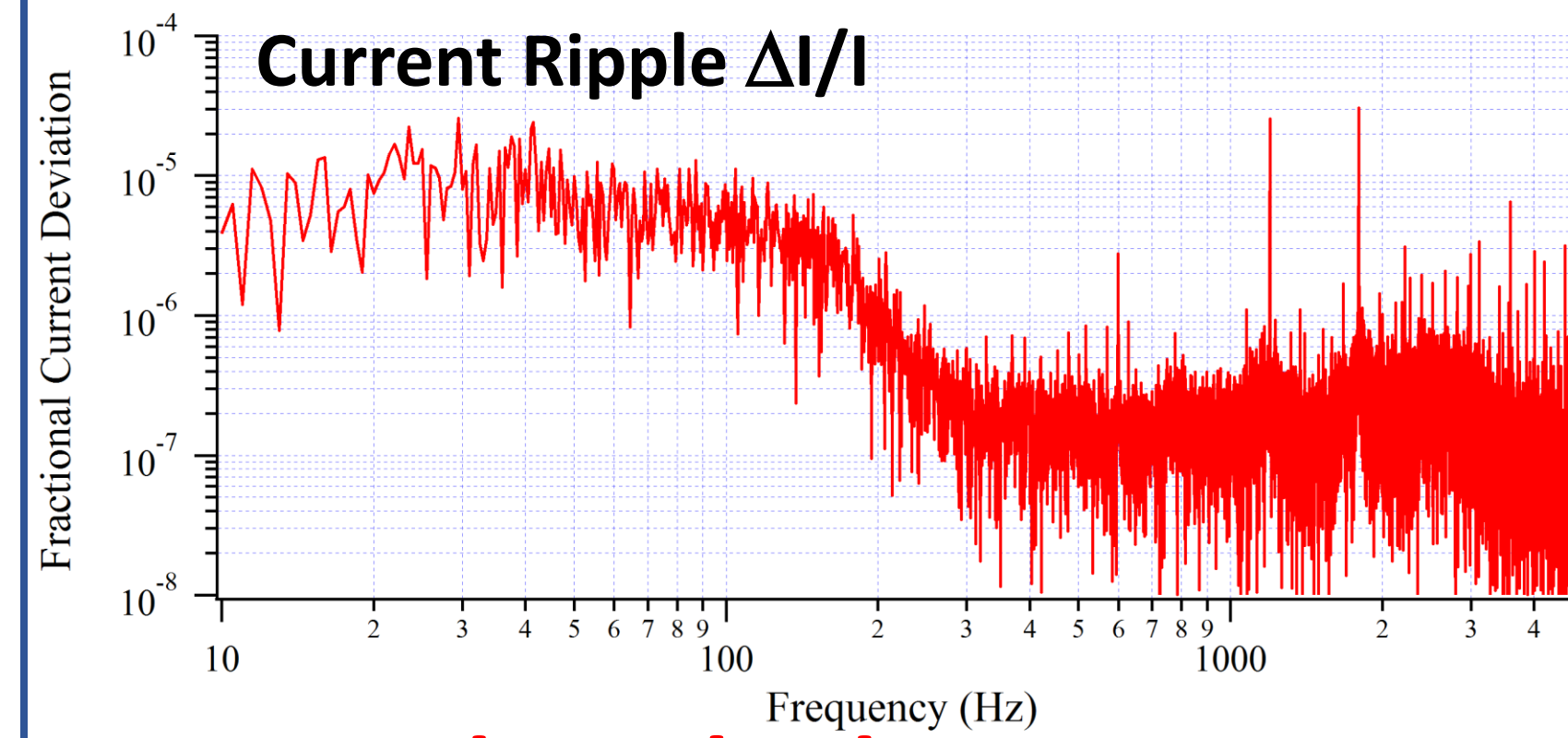

- Large current ripple causes ν fluctuation
- Dominant current ripple is at < 100 Hz
- Direct ν measurement is not possible during the user operation

Proposed Method

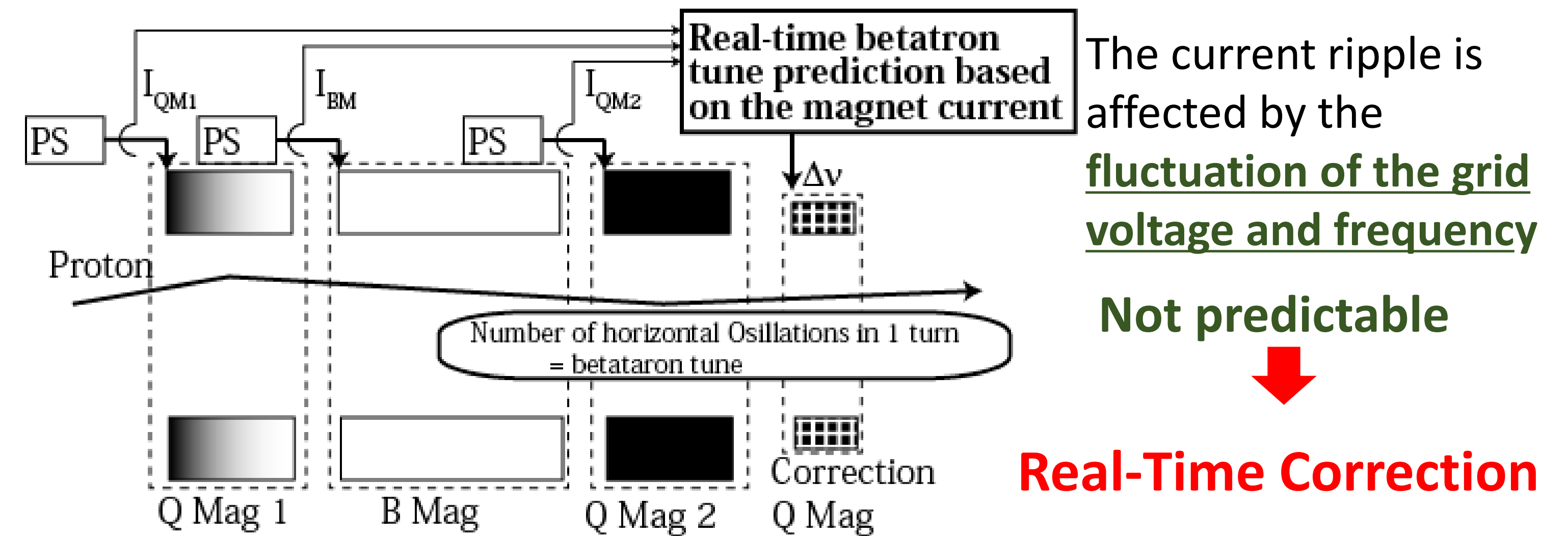

Experimental Setup at the J-PARC MR

Overview

Constraint at the J-PARC MR

The magnet current regulators are located at 3 different buildings

The current regulator of the corrector is located at the 1 building

8 current regulators are chosen.

- All 96 bending magnets
- 96 (out of 216) quadrupole magnets

1. The AD conversion of the current deviation ΔI @ each regulator
2. All digitized ΔI s are sent to the corrector via optical fibers
3. The FPGA board converts all ΔI s to the ν .

FPGA Board

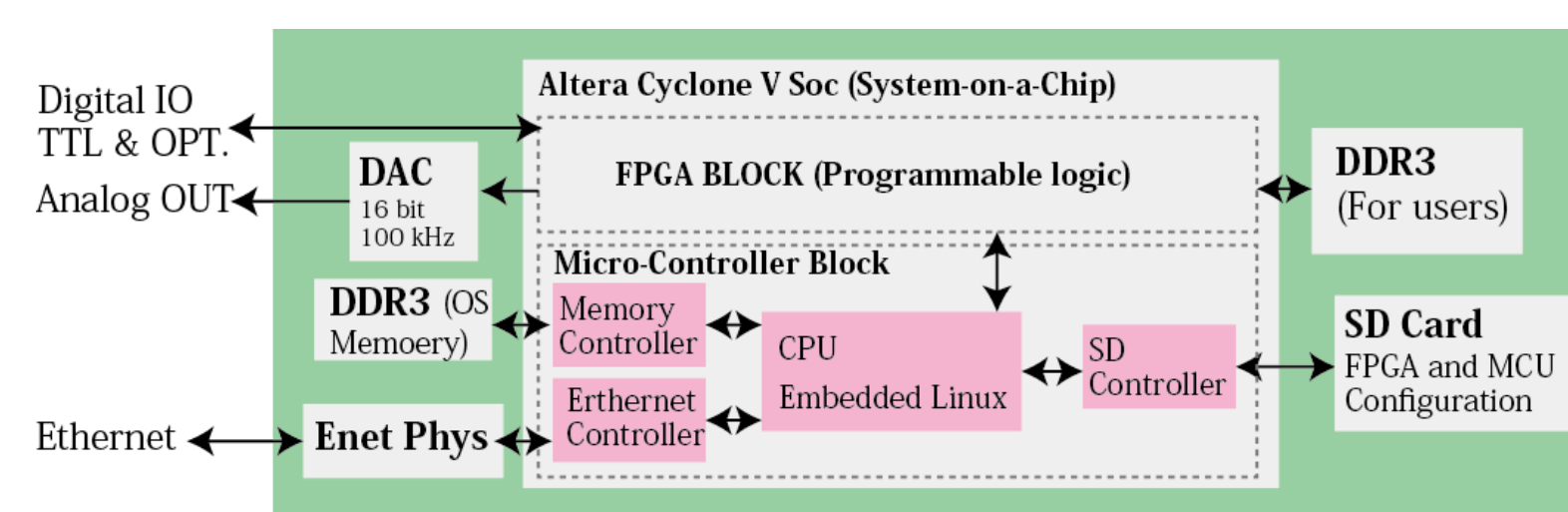
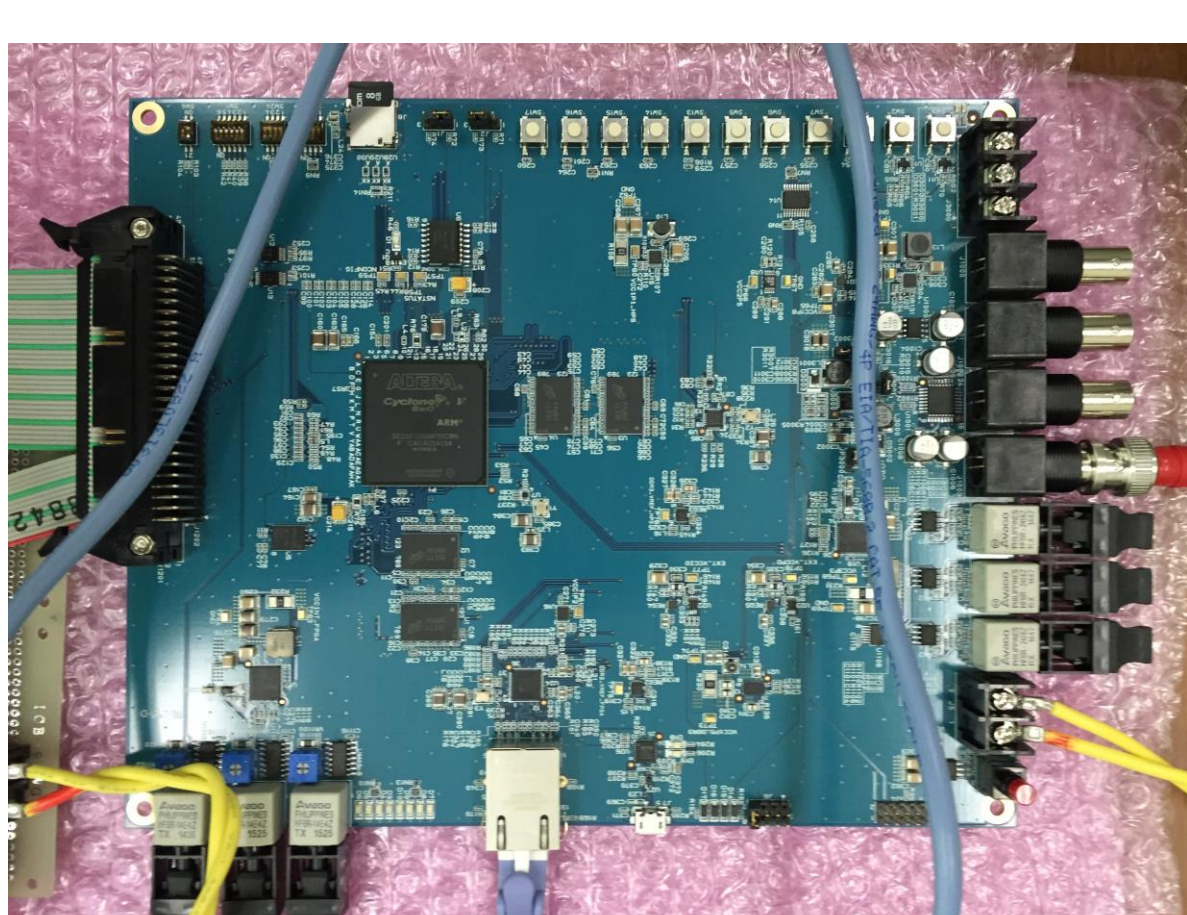

FPGA : Altera Cyclone V Soc (System-on-a-Chip)
DDR3 : 2 GB, 1 GB for User, 1 GB for OS
Digital IO: LVTTTL and Optical
Analog Out : 4ch 16 bit DAC
Others: Giga-bit Ethernet, On-board flash, μ SD

AD Board

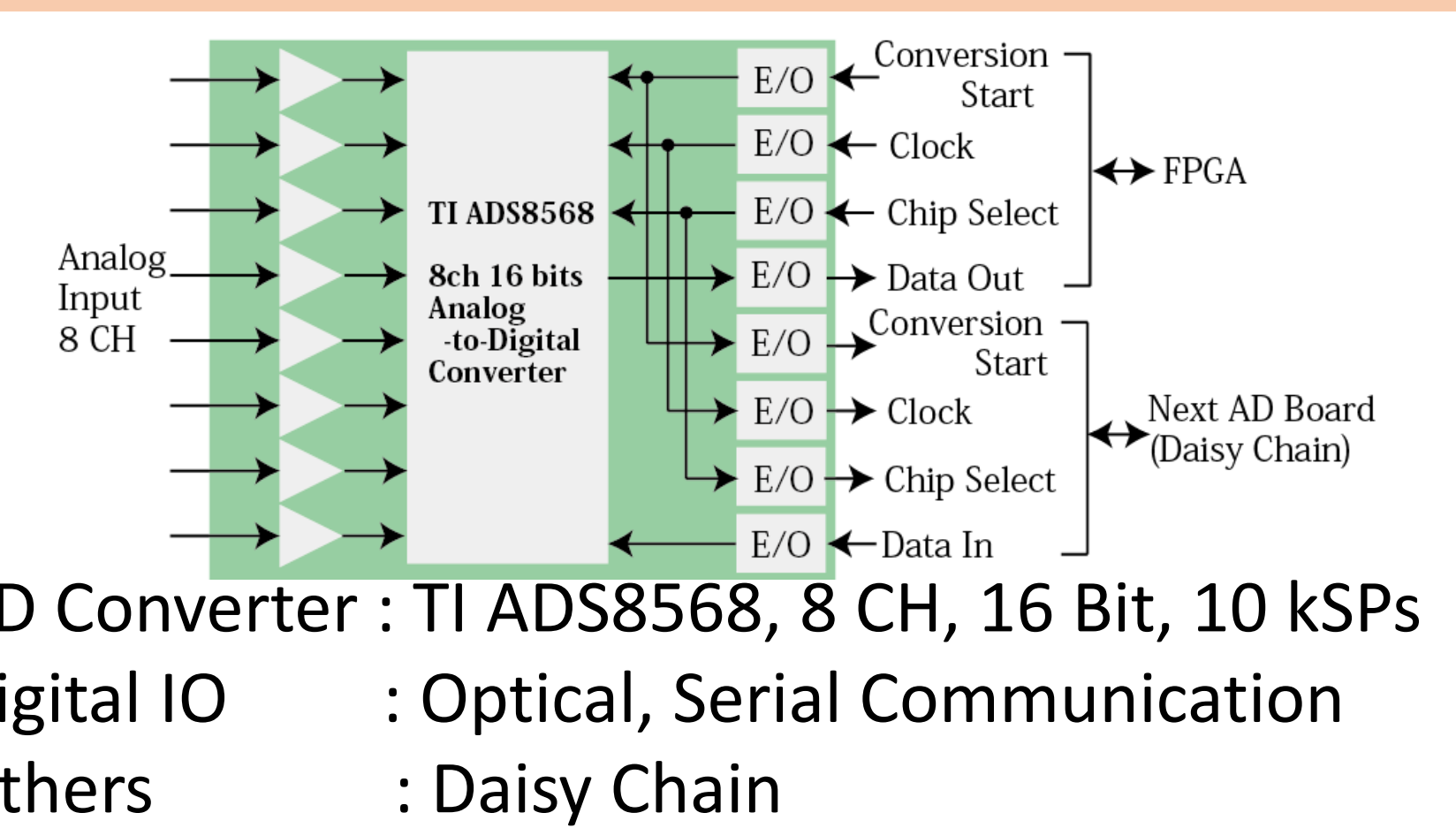
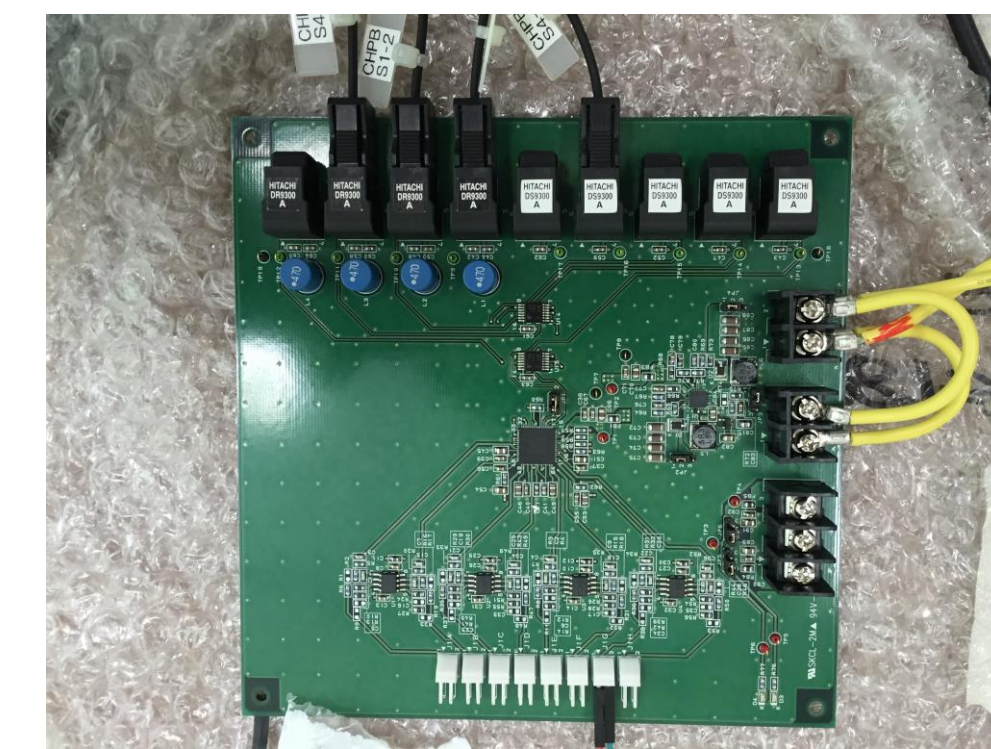

Firmware Design

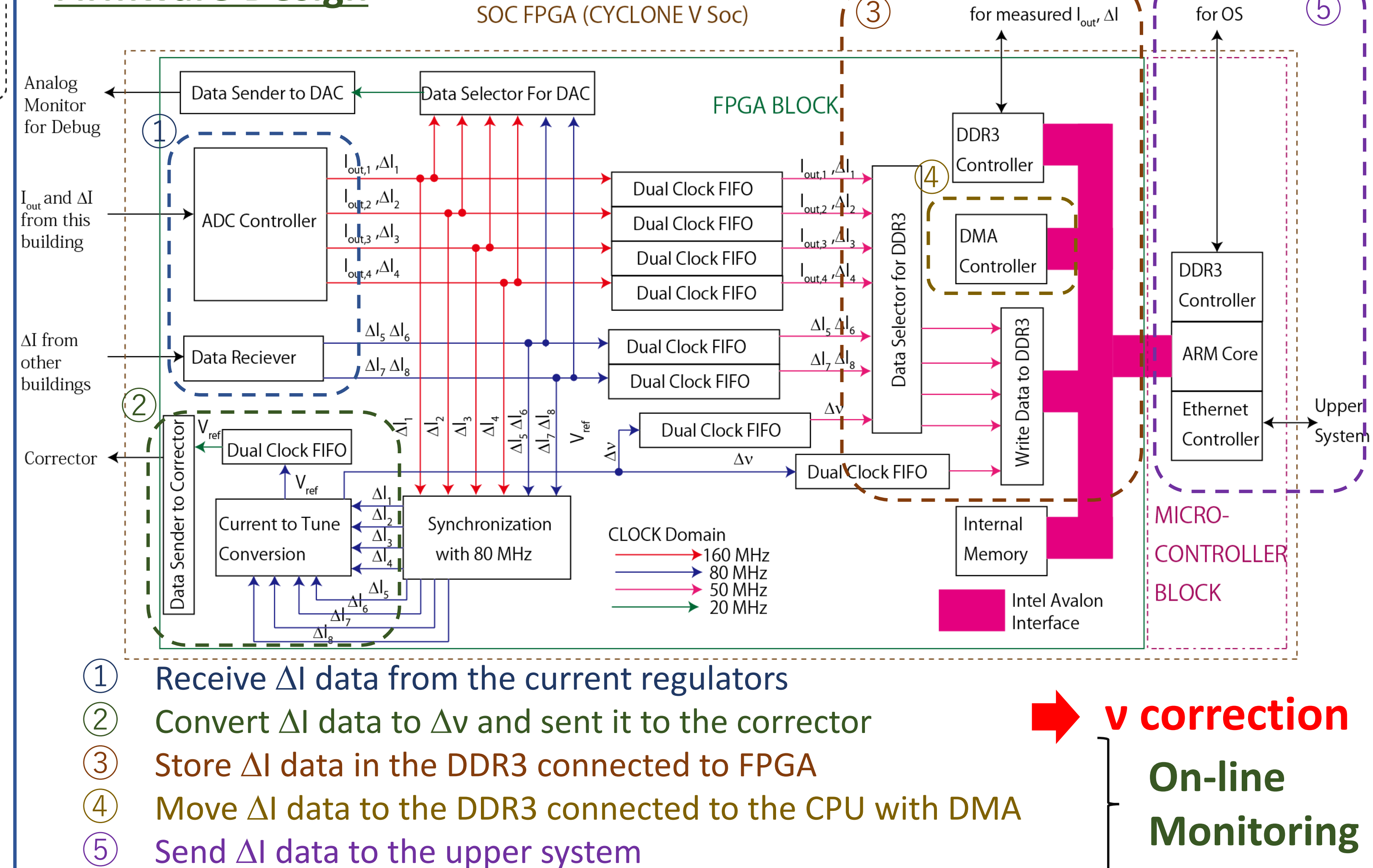

Comparison with the Direct measurement

Direct ν Measurement

Frequency measurement of the betatron oscillation excited by the stripline kicker.

The tendencies of the time variations are roughly same

Possible reasons for the discrepancies

- The precision of the direct measurement
- Not all magnet currents are used.

Direct Measurement

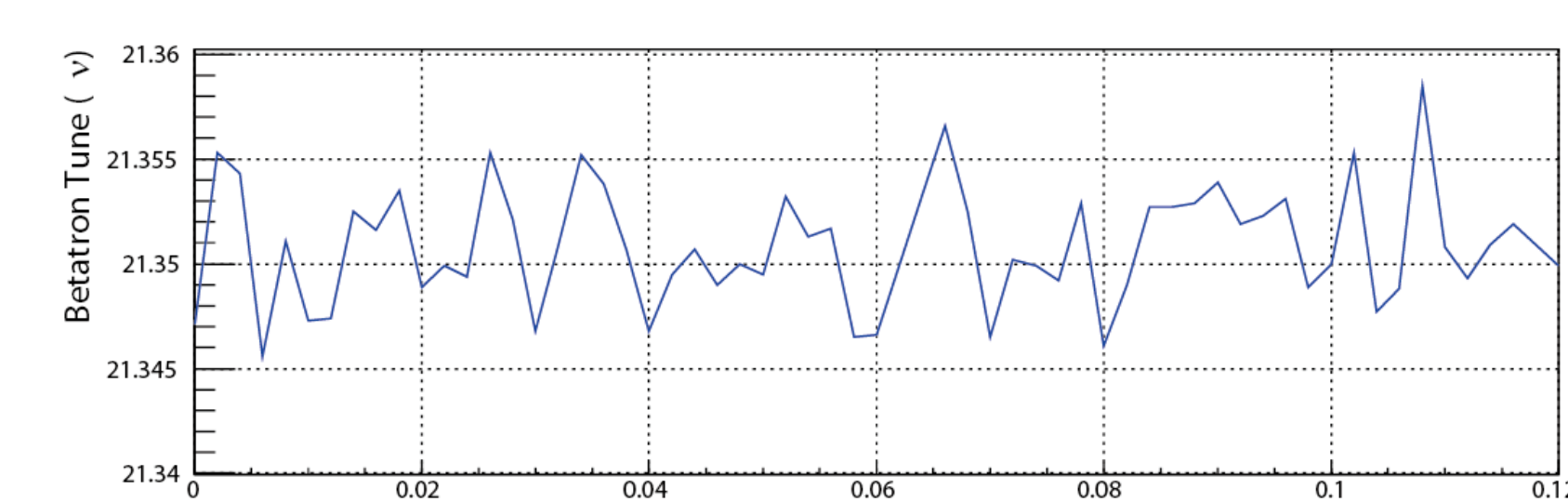

Real-Time prediction with ΔI s (this system)

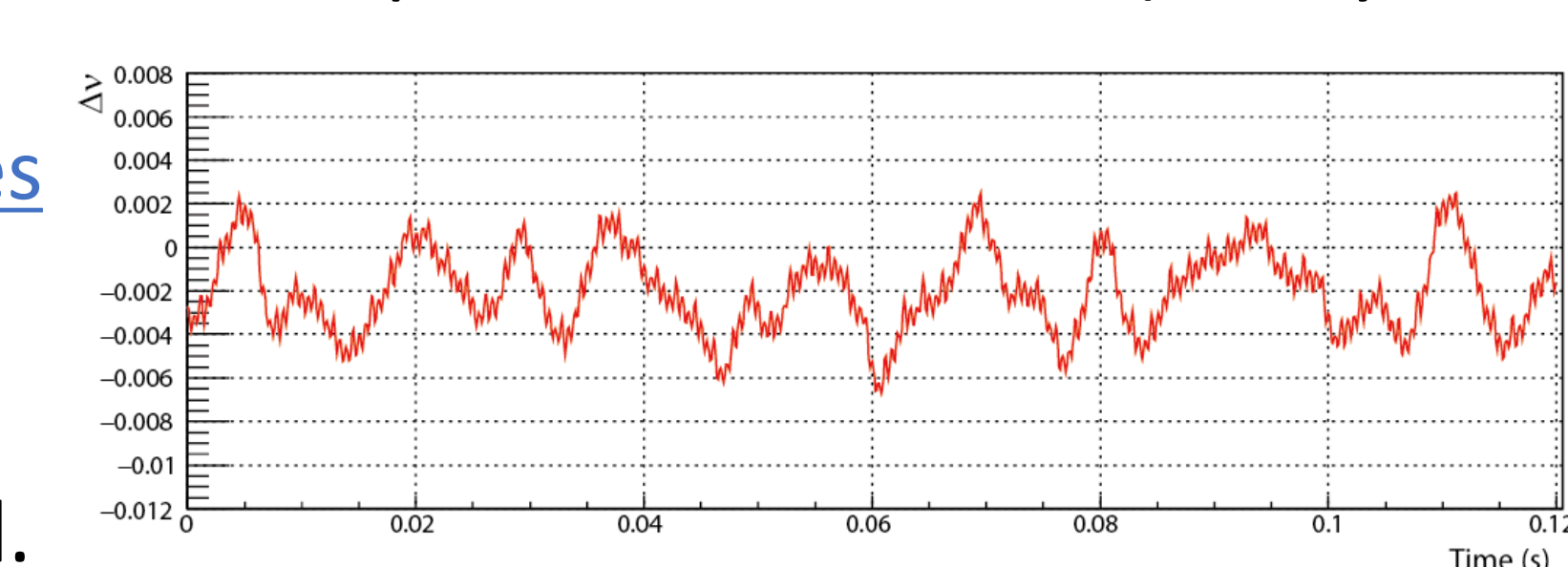

ν Correction using the System

- Direct measurement with the corrector turned on.
- Sensitive to the ν variations below 250 Hz

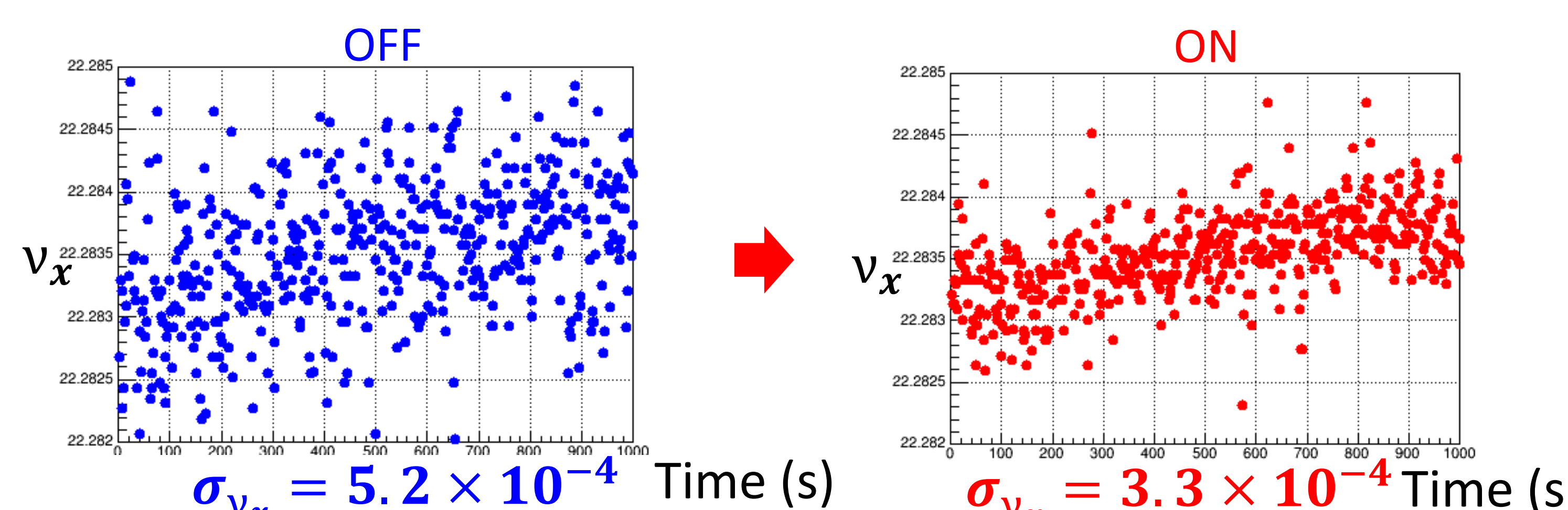

Conclusion

The proposed system can reduce the ν fluctuation by 43 %