

# Application of PROFINET IO in Neutron Scattering Instruments

H. Kleines, A. Ackens, F. Suxdorf, JCNS, Forschungszentrum Jülich, Germany

**Abstract:** The control systems of all neutron scattering instruments implemented by the Jülich Centre for Neutron Science (JCNS) are based on Siemens PLC technology. Historically PROFIBUS has been used for the communication of PLCs with supervisory computers, decentral periphery systems and other PLCs. Today, PROFINET IO is the most commonly used industrial real time Ethernet system and naturally supported by Siemens PLC systems. As a consequence, all new neutron instruments of JCNS are based on PROFINET IO. For the interfacing to supervisory computers based on CPCI, a CPCI carrier board for PC/104-Plus mezzanines has been developed, allowing the transparent use of the Siemens PC/104-Plus PROFINET IO controller CP1604 in CPCI systems. Linux is used as the operating system for supervisory computers and the software development employs the PROFINET IO-Base-API, commonly supported by Siemens PROFINET IO controllers. On top of this API, an application protocol for the communication with PLC-based motion systems has been implemented.

## Jülich-Munich Standard

- Framework for neutron instrument control developed by JCNS and TU Munich based on TANGO
  - Slow control based on industrial automation technology:
    - PLCs: Siemens S7
    - Fieldbus Systems: originally PROFIBUS DP, now PROFINET IO
    - Decentral periphery systems: Siemens ET200S/SP/pro
- ⇒ Identical technology for motion, personal safety, vacuum, sample environment,.....



S7-1500



ET200S

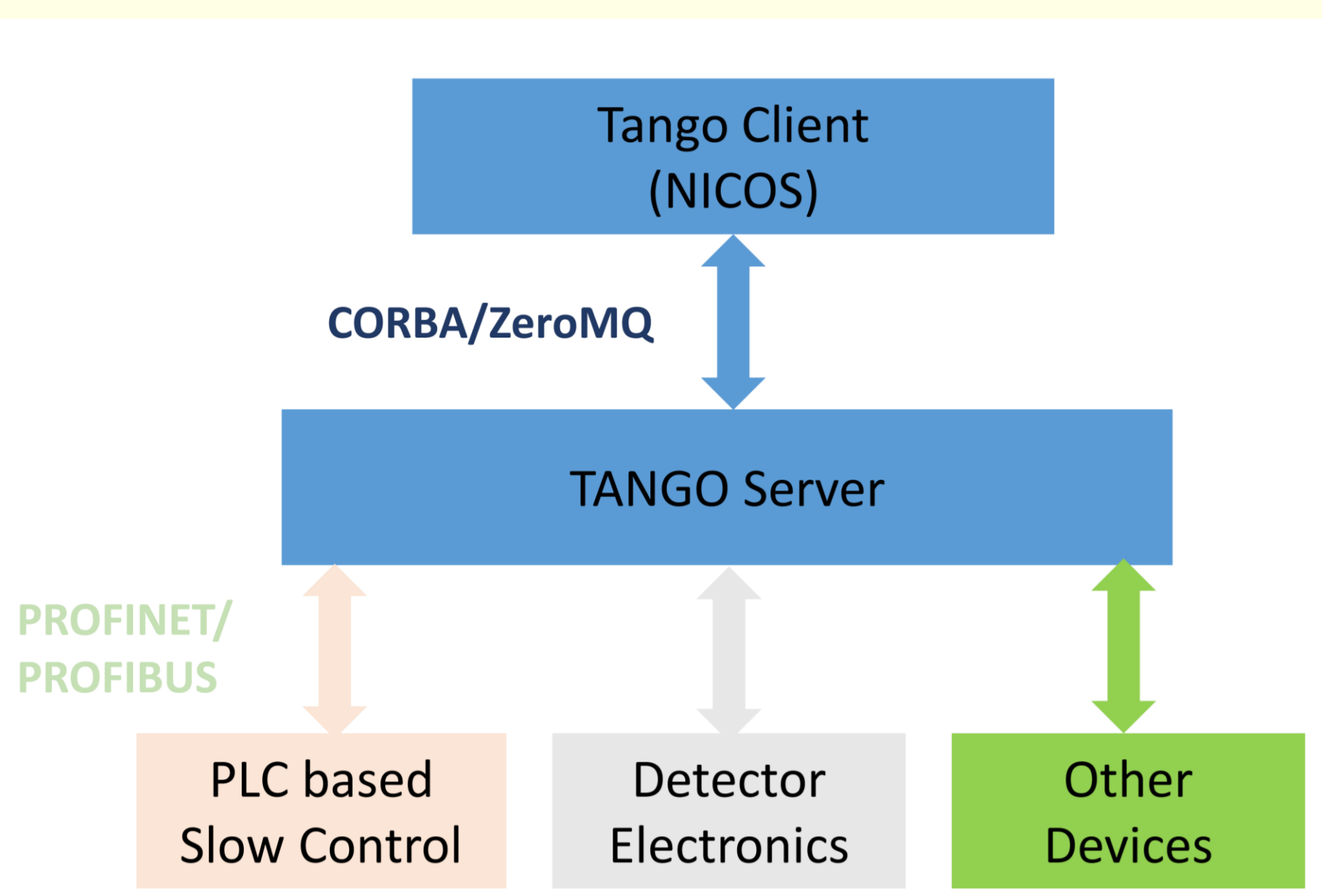

## Control System Structure of Neutron Instruments implemented by JCNS

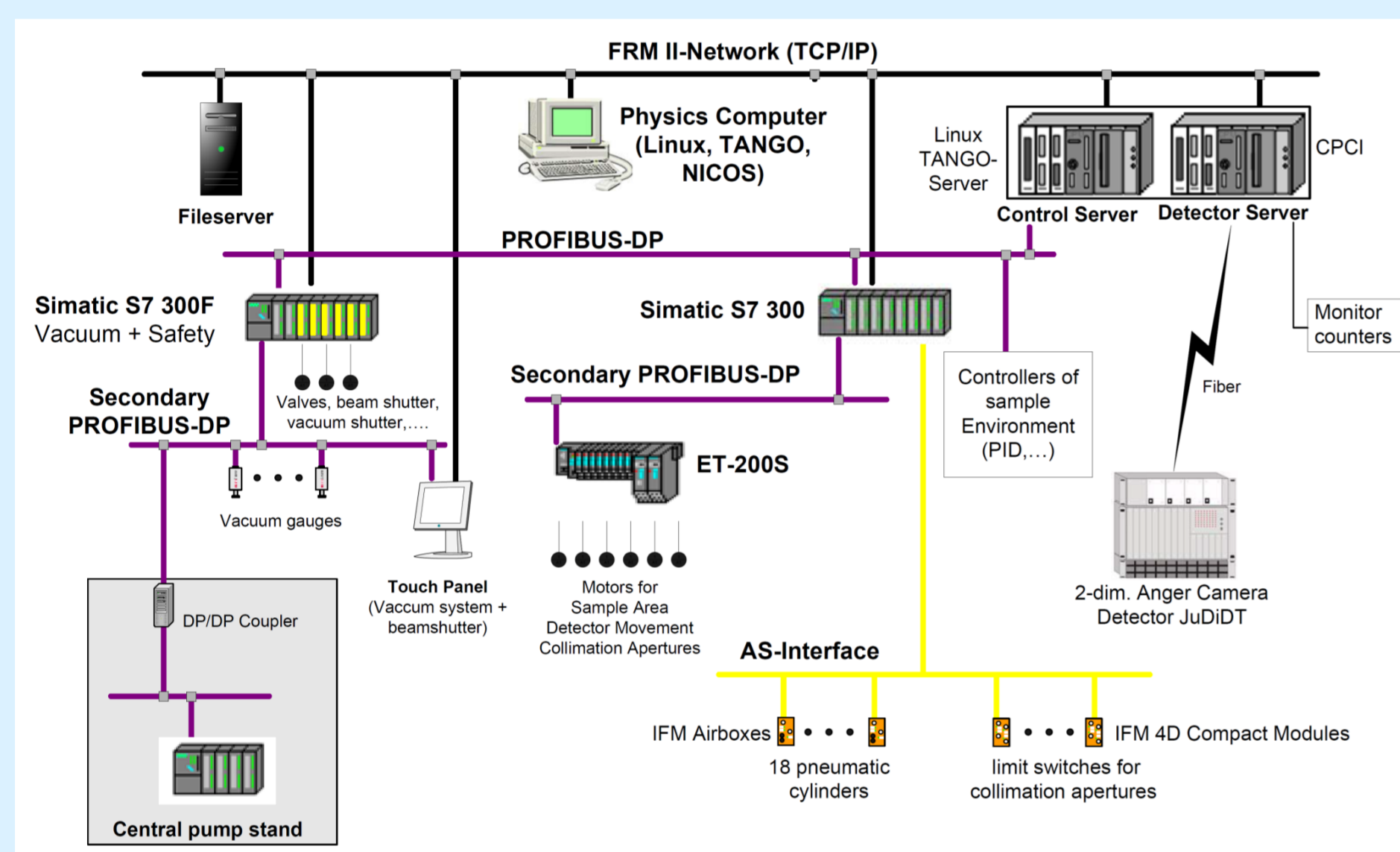

Neutron Small Angle Instrument KWS1: Classical Architecture only based on PROFIBUS and AS-i

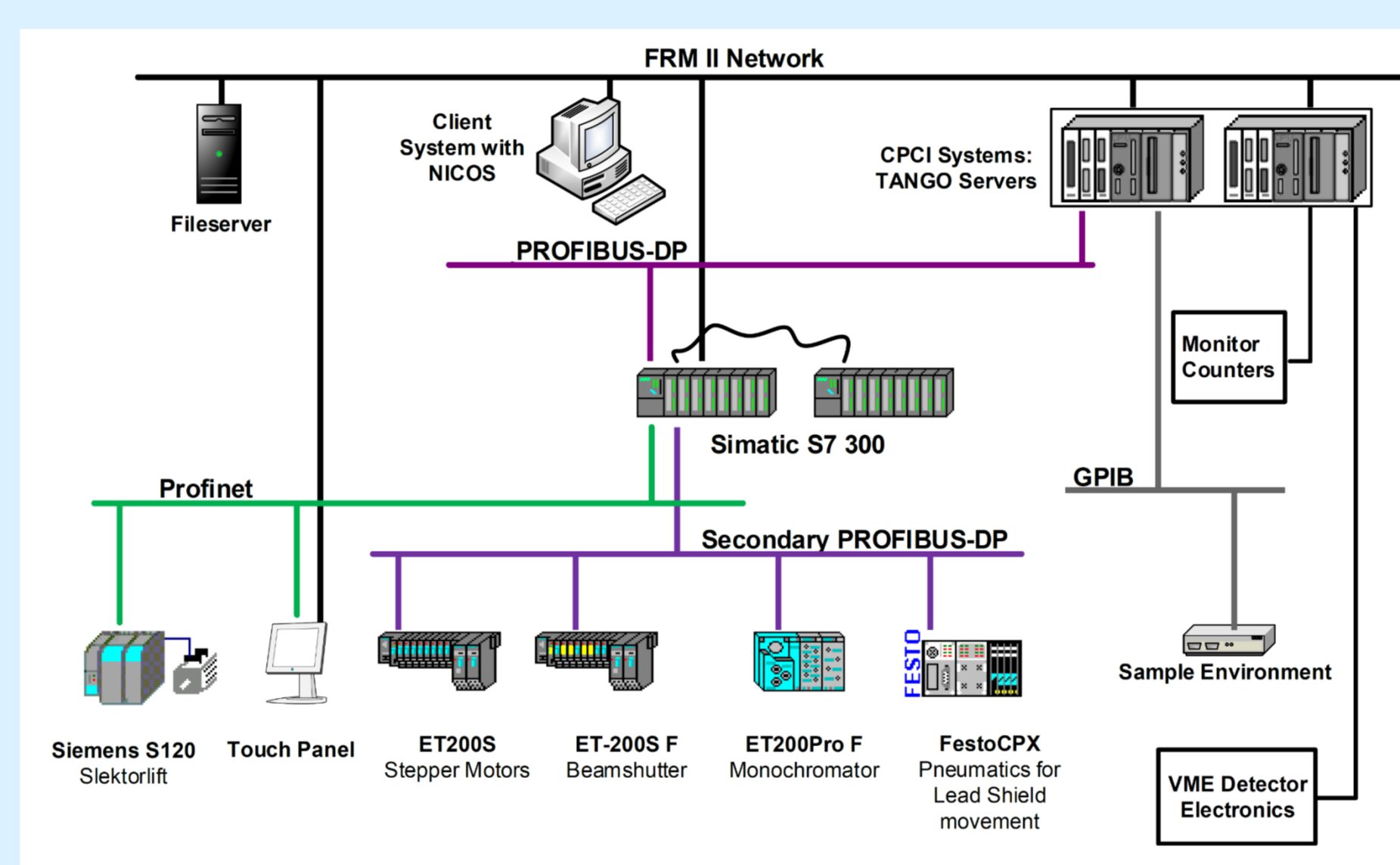

Neutron Time-of-Flight Instrument DNS: Mixed Architecture based on PROFIBUS and PROFINET

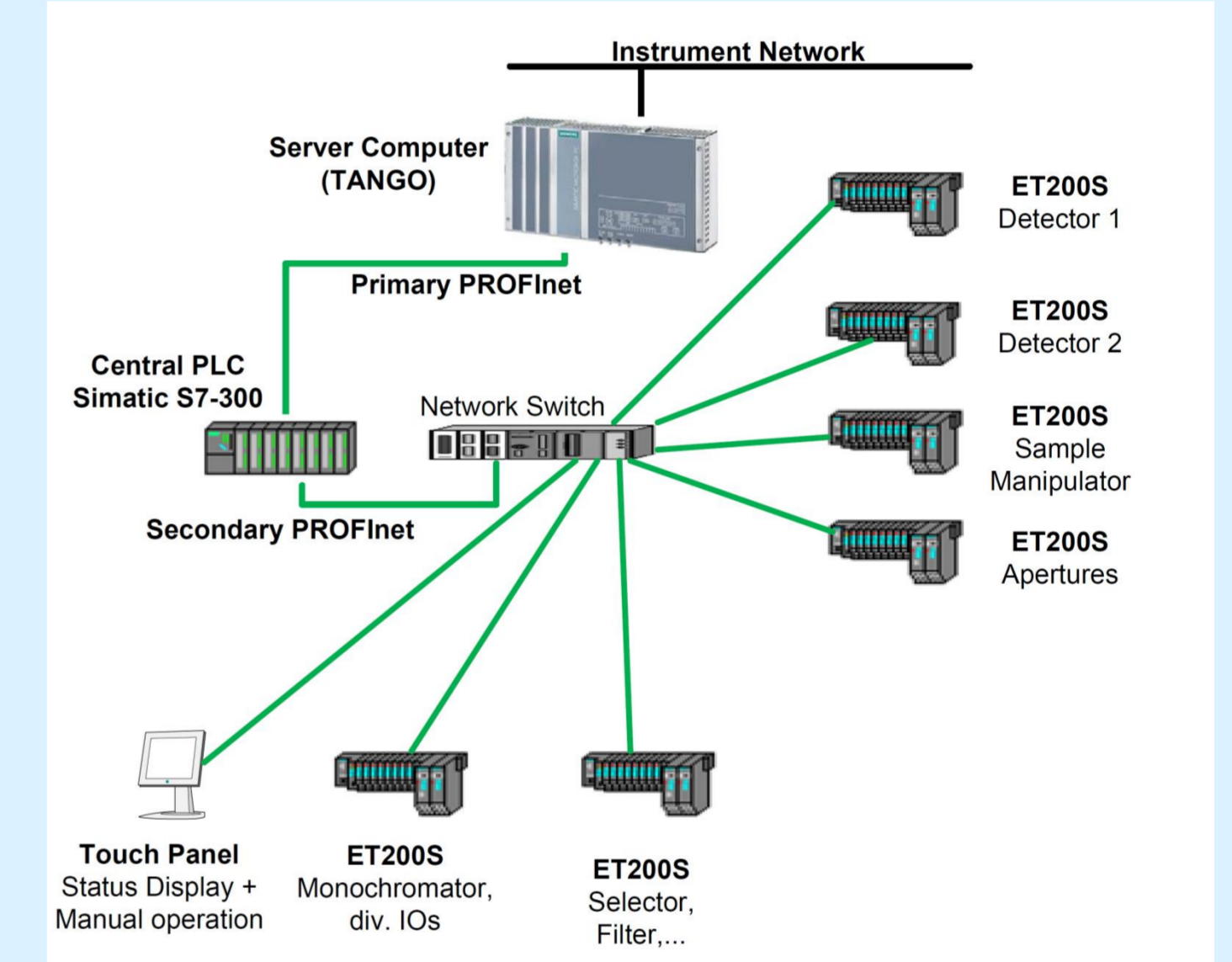

Motion subsystem of Neutron Imaging Instrument ANTARES: New Architecture only based on PROFINET

## PROFINET IO Technology

- Leading industrial Ethernet technology standardized in IEC61158
- Naturally supported by Siemens products
- Standard TCP/IP data and PROFINET IO data on the same cable
- Powerful diagnostics and configuration
- Real Time (RT) mode: Prioritized cyclic data with optimized protocol stack
- Isochronous Real time (IRT) mode: time synchronization according to IEEE 1588 ( $< 1 \mu s$ )

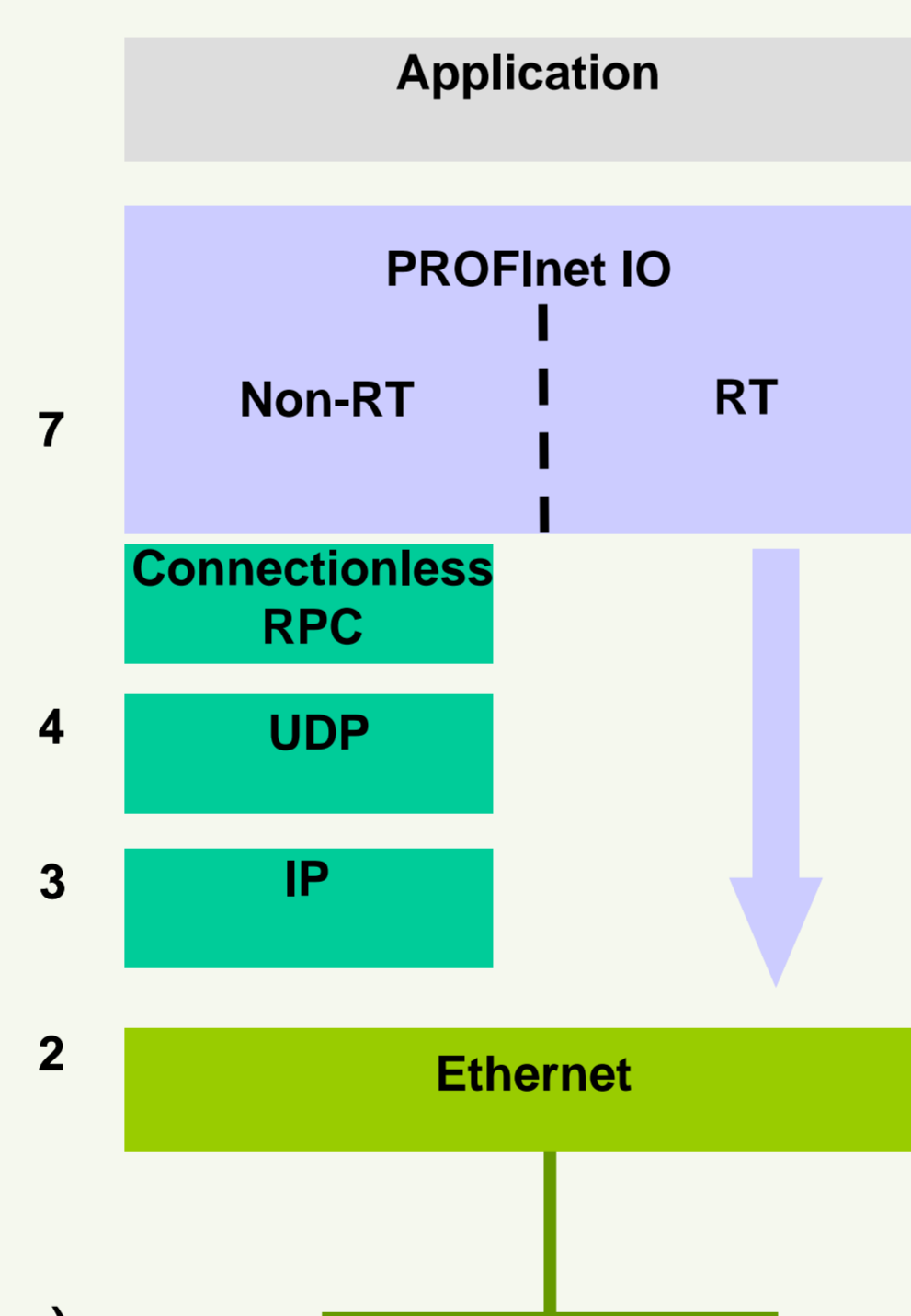

- Decentral controller/device concept similar to PROFIBUS DP
- Modular device model defined by GSDML files
- Producer/Consumer model: cyclic exchange of IO-data

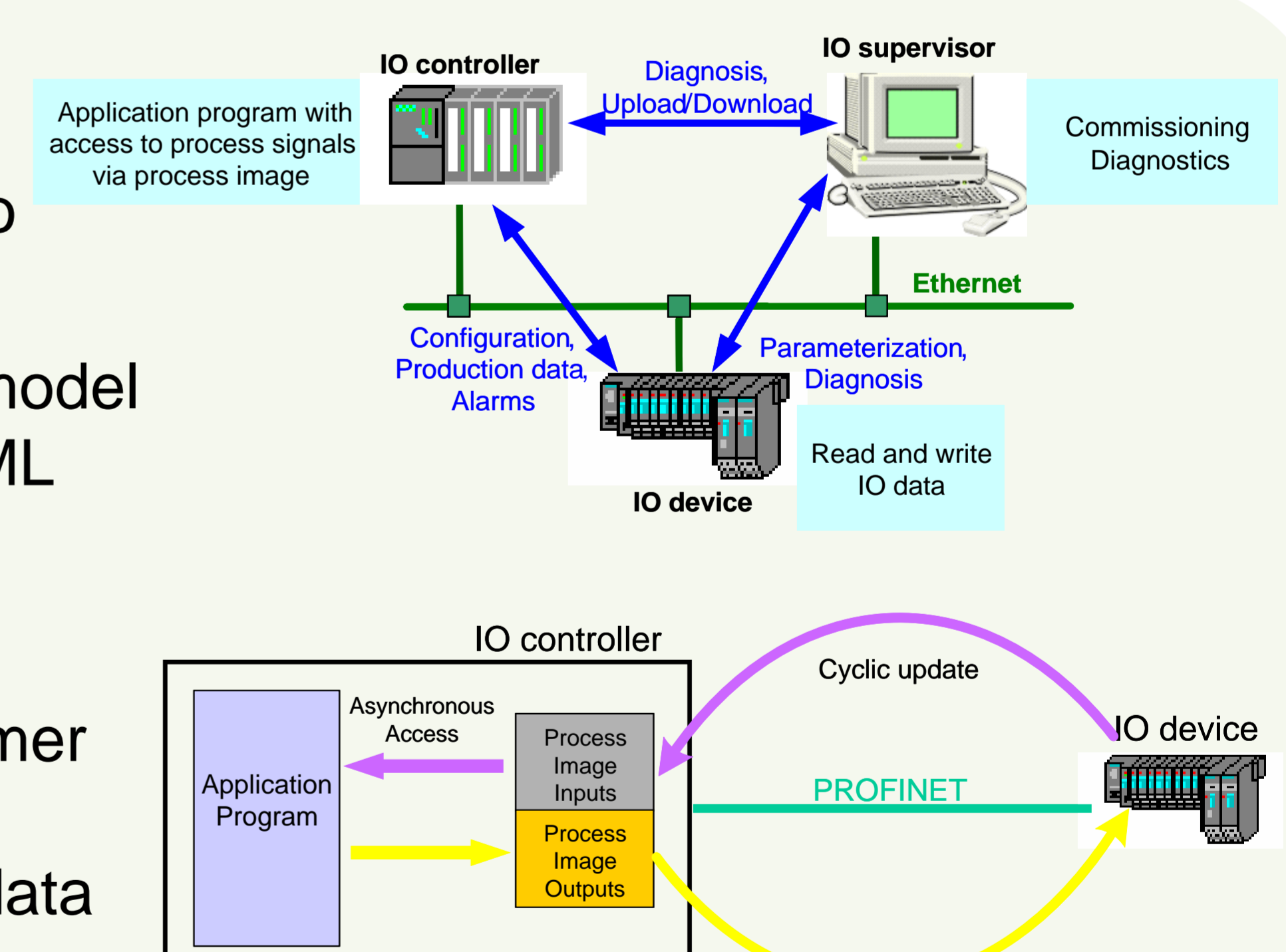

## CompactPCI PN IO controller implementation

- Siemens product preferred due to direct integration into PLC project: PC104+ mezzanine CP1604
- ⇒ Development of CompactPCI carrier required
  - Based on IDT TSI350 PCI-to-PCI bridge
  - 4xRJ45 module directly integrated



Siemens CP1604 (PROFINET IO controller as PC104+ mezzanine)

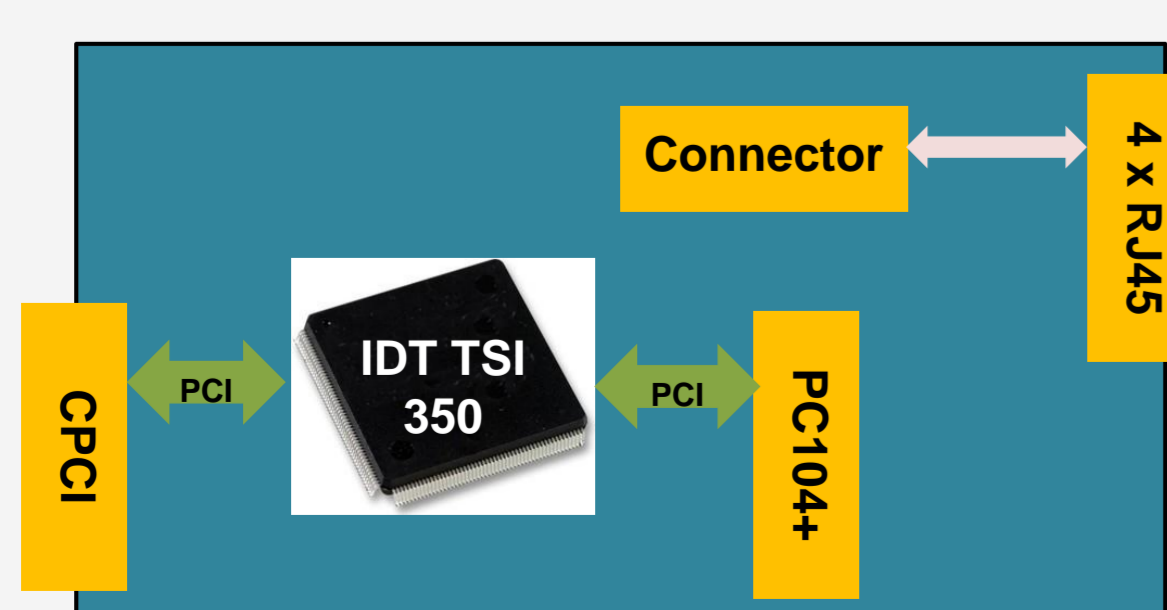

Carrier board block diagram



CompactPCI carrier board for PC104+

## SW structure

- Standardized IO-Base API supported by all Siemens PCI, PCIe and PC104+ PN IO controllers as well as by pure software implementations
- IO-Base library + device driver available as Linux source code
- TANGO device server implements optimized application protocol for IO access, especially for motion
- Standard data – e.g. positions – directly readable by mapping into IO space
- APIs almost identical to PROFIBUS DP