

The Laser Control System for a Calibration Facility of Light Detector

S. Mastroianni, R. Di Stefano, O. Escalante, M. Iacovacci, F. Marignetti

Abstract—Laser calibration facilities play a key role in the study and characterization of detectors like electromagnetic or hadronic calorimeters. They can be operated both during physics data taking and off run. Typically these facilities are based on a lasers source which deliver light to each detector element via a light distribution system. The laser control system typically manages the interface between the experiment and the laser source, allowing the generation of light pulses according to specific needs as detector calibration, study of detector performance in running conditions, evaluation of DAQ performance. Any specific implementation depends on hardware features. As an example light pulses could be generated according to a physics distribution as it appens in physics run or real data taking. In this case light pulses should be generated according to a pattern which follows a programmable function and changes on a statistical base event by event. In this work we present a laser control system for calibration of a calorimeter. It is a custom solution based on an hybrid platform hosting an FPGA and an ARM processor. We present the system architecture and the performances of a preliminary implementation.

I. INTRODUCTION

The laser systems for detector calibration are largely used in many experiments of particle and nuclear physics. They are fundamental to correct the response in the energy scale for the electromagnetic or hadronic calorimeters systems. They are also used to monitor the performance and timing properties of the detector. The laser facilities can be operated both within dedicated calibration runs (i.e. studies of linearity) or during the data taking to monitor the stability of the detector.

Moreover, during the test/debug phase, the calibration facilities are required to generate simulated events with the same characteristics of the physics ones in order to reproduce the run conditions. The presence of a control system for a laser facility becomes therefore very fundamental mainly for the complex and demanding calibration system.

The main task of the laser control is to fire the light pulses, according the different operation modes, and to manage the interface with the Trigger and the DAQ system of the experiment. It manages all the control activities of the monitor electronics providing them the timing signals for data processing.

This paper is organized as follows: in the Sec. II a typical calibration system for the light detector will be described; the laser control functionalities and architecture will be discussed

in Sec. III; then in Sec. IV the laser control implementation and some test measurements are presented.

II. THE CALIBRATION SYSTEM

The method used for photo-detector calibration is to distribute a short laser pulse directly into each detector station via a chain of optical fibers and other optical elements. A schematic blocks of a calibration system for a photo-detector station is displayed in Fig. 1 including the interface with the Trigger and data acquisition system (DAQ). To illuminate the detector station, the Laser pulses are sent into a diffuser and then coupled into an optical fiber distributing the light directly to the module. Some photo-detector elements are also needed to monitor any fluctuation in time of the light source and any fluctuation of the transmitted light along the optical path of the light distribution too. All these elements (called respectively source and local monitors) are housed in custom boards, in the Monitor electronics crate in Fig. 1, containing the photo-detector's bias control, the electronics for signal processing and all the interface to manage the configuration and data readout.

More in general, the laser control manages the light pulse

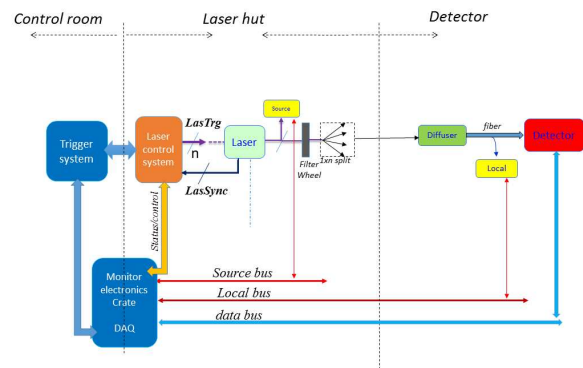

Fig. 1. A schematic view of a calibration system for light detector

distribution to the calorimeter stations and the interface with the Trigger system of the experiment; some timing signals to the Monitor electronics boards are also distributed for trigger and reference purposes. The information on the status and activity of all these electronics boards is read back and monitored.

The laser pulse generation can be operated with different modes both during the physics runs to correct systematic effects due to drifts in the response of the light devices and

Manuscript received May 31, 2016

S. Mastroianni is with INFN Sez. Napoli, Italy, Napoli

R. Di Stefano and F. Marignetti are with Universit di Cassino, Italy, Cassino and INFN Sez. Napoli, Italy, Napoli

M. Iacovacci is with Università di Napoli, Italy, Napoli and INFN Sez. Napoli, Italy, Napoli

in a dedicated calibration runs in order to test the detector and DAQ response when a specific pulse distribution function is injected. Moreover, the laser control is used to align the photo-detectors and the electronics readout. Reconstruction of the laser events helps to recognize errors in tracking code, wrong cabling and non-functioning readout electronics. The laser control is required to take care of all these operation modes and to create an user interface for configuration and control.

III. THE LASER CONTROL

The interface between the laser control and the Trigger and DAQ systems is based on a well defined sequence of signals to perform an exact and unambiguous synchronization to the physics events. This will consider the different time and data formats for several operation modes.

A. The functionalities

The main operation modes of the laser control system provide:

- time reference signal for reset, synchronization and initialization of the detector and the electronics;
- light pulse generation at programmable frequency;
- hit patterns generated randomly according an integral distribution function set by a software tool both for physics event simulation and for detector/DAQ/electronics test and characterization;

All the configurable parameters can be defined in an array of registers; a software interface allows the setup remotely.

B. The architecture

The system has been realized by using an hybrid platform with FPGA board and ARM-based processor. A schematic block diagram of the laser control is shown in Fig. 2. The interface with the trigger system is implemented in the *Trigger* block where an external trigger defines the beginning of the laser sequence. The *Laser* block drives the laser device signals.

The operation modes are managed in the *Laser Control Mode* block where it is possible to select for different modes and configure the correspondent parameters for trigger distribution.

C. The operation modes

Now a short discussion is reported on these two main uses of the laser control system.

The “on-line” calibration mode operating during the physics runs is essentially based on a programmed number of pulses issued during an enable gate conveniently delayed with respect the external trigger. The width of the enable signal and the number of pulse in the window are programmed defining the pulse rate. The time duration of the enable gate spans from few μs to ms ; the programmable pulse rate ranges from hundreds of Hz to MHz.

The “off-line” calibration mode used principally within a

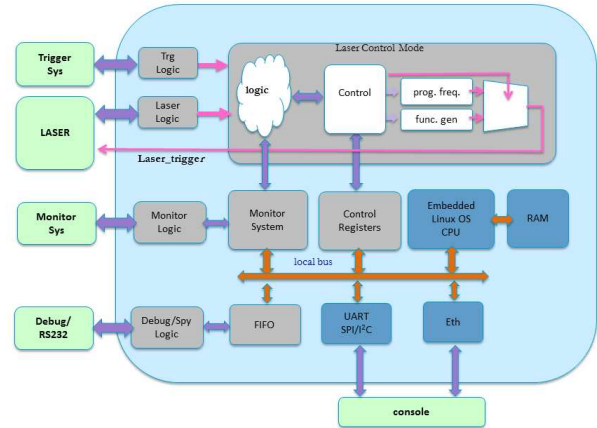

Fig. 2. The architecture of the laser control

dedicated calibration run is based on the interaction between software and hardware components. Essentially a software process builds a frame containing all the time hit sequence (in an enable gate) and sends it to the hardware block for the pulse generations. In fact, on the external trigger a local time counter starts and every Δt time step (bin size of the distribution) a comparison between the local time register and the pointed time record, extracted from the frame is carried out. In case of a match, the digital comparator outputs a laser pulse. Then a new hit time word is extracted and the comparison process can go ahead until the end of frame is detected.

IV. TEST MEASUREMENTS

In this section we report on the realization of a prototype based on a Spartan6 from Xilinx[1] and on a AM3358[2] (1GHz ARM A8 processor). The communication between the ARM and the FPGA elements, used for configuration and monitoring, is based on SPI. It is a synchronous serial communication that operates in full duplex mode with a clock frequency selected between 1 and 10 MHz. The platform provides several GPIO pins to implement the interrupt service routines by using a polling algorithm and some ADC devices to sample analog signals.

The system configuration and monitoring are controlled by an embedded processor: its main components (RAM block, Ethernet and I/O peripherals) are depicted in the Fig. 2. The use of an embedded processor has the advantage of being flexible by means of the device tree configuration. In fact the operating system parses the data structure at the boot time and configures the kernel and which device drives to load. The main elements between busses and peripheral are I2C, SPI, ADC and GIPO.

A test bench has been assembled as in Fig. 3; two boards are shown: the laser control under test and another FPGA board used for measurements. In fact, it distributes the trigger signal to the laser control and measures the time for each laser pulse. The system configuration and all the operation modes are managed by a remote PC connected via an Ethernet link

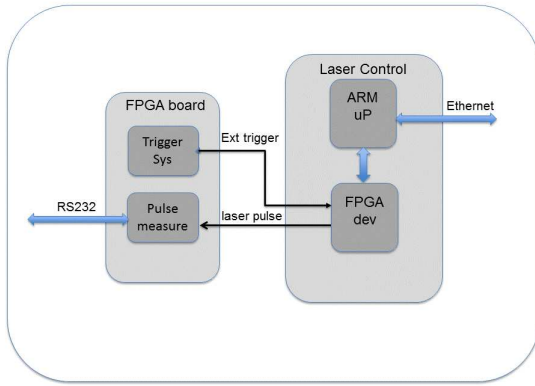

Fig. 3. Test bench setup for laser control

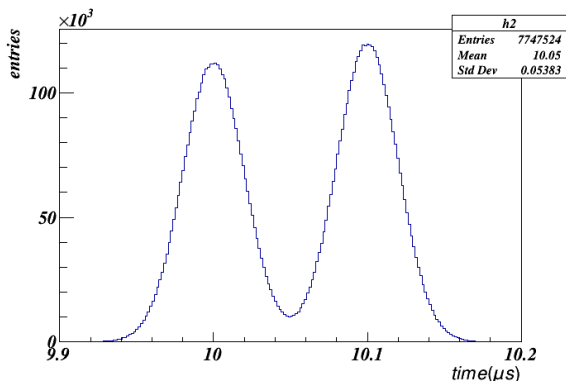

Fig. 4. Measured hit distribution integrated

or locally over an USB connection. Several measurements at fixed frequency mode have been done.

Of a great interest is the mode that generates hit patterns randomly used for test and debug of DAQ and electronics. As an example, Fig. 4 shows the measured hit distribution integrated for a double Gaussian signal with two hits for each sequence.

V. CONCLUSIONS

The laser control has been designed to allow the management of the calibration system based on photo-detectors exploiting the hardware performance and the software flexibility well integrated in a robust and portable system that can operate in a limited access environment. The interface with the Trigger and the DAQ system represents an interesting benefit that gives to the system the possibility to synchronize the light pulse generation within the data collection operating during the physics runs.

With the increasing of the power and flexibility of the embedded processor the use of computing resources in a such demanding application becomes strengthened and affordable.

REFERENCES