

Low Phase Noise Local Oscillator and Clock Generation for Cavity Field Detection

Mateusz Żukociński,

Krzysztof Czuba, Łukasz Zembala
Institute of Electronic Systems
Warsaw University of Technology
Warsaw, Poland

* M.Zukocinski@elka.pw.edu.pl

Uros Mavrič,

Matthias Hoffmann, Frank Ludwig
Deutsches Elektronen-Synchrotron
Hamburg, Germany



20th Real Time Conference
Padova, Italy 7.06.2016

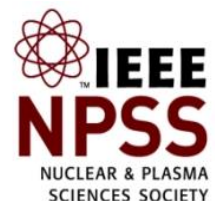

Outline

- Introduction
- Frequency synthesis concepts
- Mixing technique
- Analysis
- Prototyping
- Final design
- Results
- Summary

Introduction

> RF cavity field control system

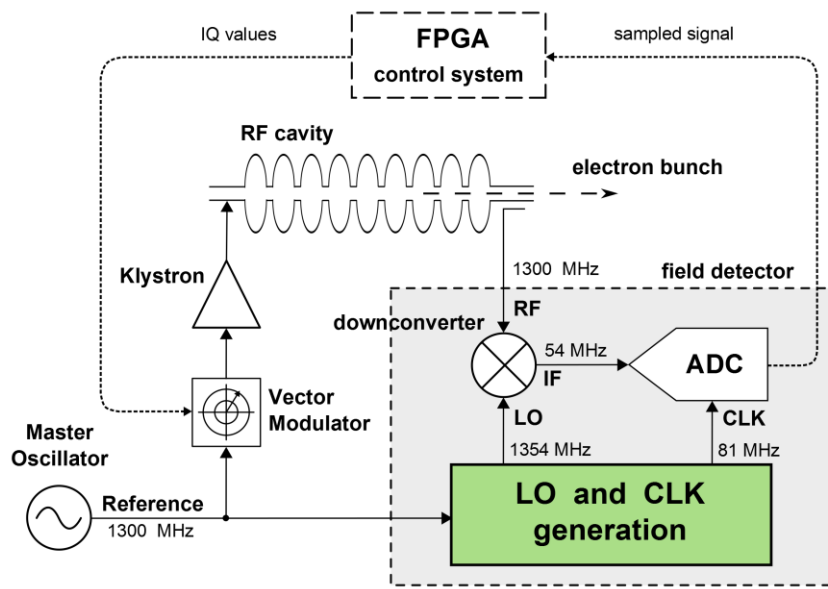

LO Generation Module - LOGM

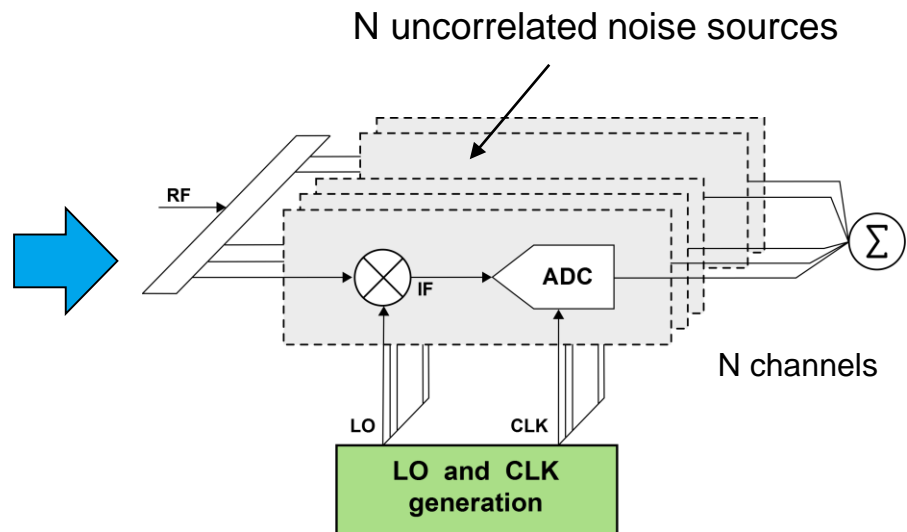

1 correlated noise sources !!!

- > Local Oscillator (LO) signal is a crucial contributor to the receiver phase noise
- > Ultra-low phase noise LO is a must
 - < 3 fs RMS time jitter [$10 \text{ Hz} \div 1 \text{ MHz}$]
 - < -160 dBc/Hz noise floor
- > Low phase noise Clock (CLK) is needed

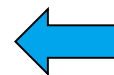

spec for the European XFEL

> LOGM requirements

- Input signal:
 - » 1x REF 1300 MHz +21 dBm
- Output signals:
 - » 3x REF 1300 MHz +11 dBm (uVM, HOM, KLM)
 - » 2x REF 1300 MHz +3 dBm (uDWC)
 - » 9x LO 1354 MHz +14 dBm
 - » 9x CLK 81 MHz 1.2 Vpp square
- Synchronization RESET functionality for 81 MHz CLK signal
- LO power adjustment [+12 ... +17 dBm]
- LO performance:
 - » RMS additive jitter < 3 fsec (10Hz - 1MHz)
 - » Phase noise floor < -160 dBc/Hz
 - » Spurious-free range > 80 dBc
- Diagnostics:
 - » RF signals monitor outputs
 - » Power level detectors, temperature sensors
 - » Power supply management
- Packaging:
 - » standard 19" crate, low-profile (1U high)

XFEL system frequency configuration:

- REF 1300 MHz
- LO 1354 MHz
- IF 54.16 MHz (1300 / 24)
- CLK 81.25 MHz (1300 / 16)

Frequency synthesis concepts

> Phase-lock loop technique

Advantages

- shaping phase noise characteristic
- superior performance possible

Disadvantages

- lack of small PCB-mount oscillators with sufficiently good performance



> Mixing technique

Advantages

- low phase noise
- sufficient performance possible
- components easily available
- easy to integrate on PCB

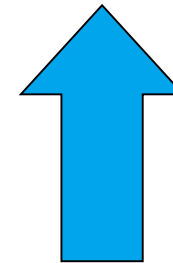

Mixing Technique

> Single-stage mixing

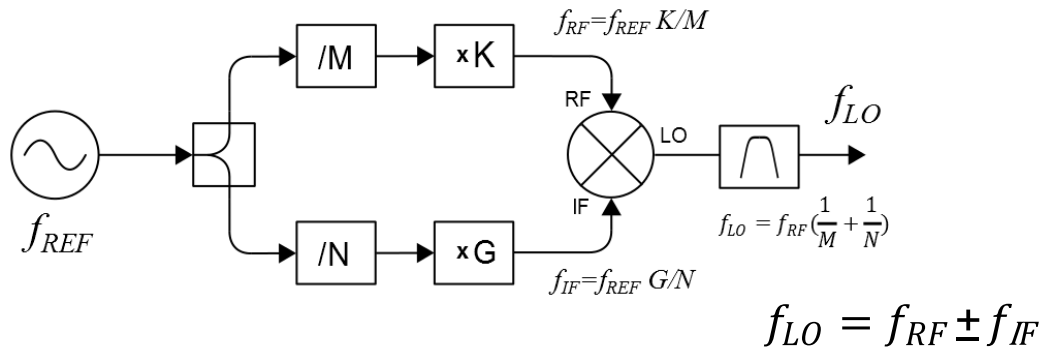

> Multi-stage mixing

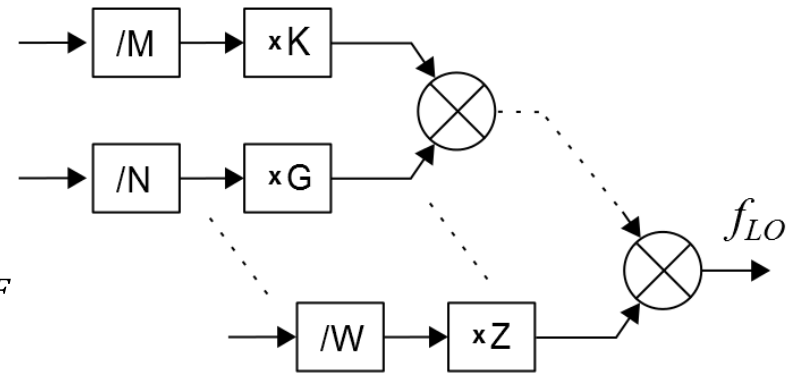

RF and LO are close each other !!

➡ it is hard to select the LO out of the mixer spectrum (filtration)

- Simple design
- Minimum number of components
- **High spec for LO filter**

- Complex design
- High number of components
- **Relaxed spec for LO filters**

Analysis

> Single-stage mixing

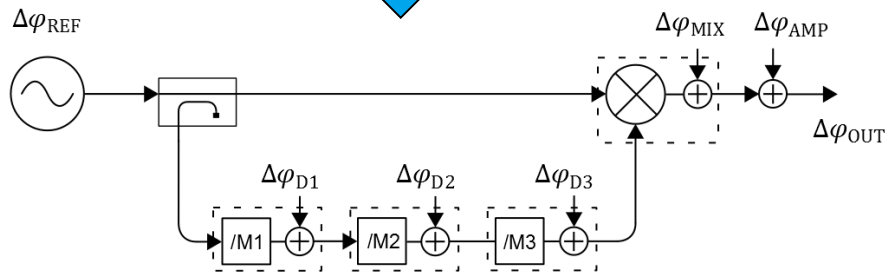
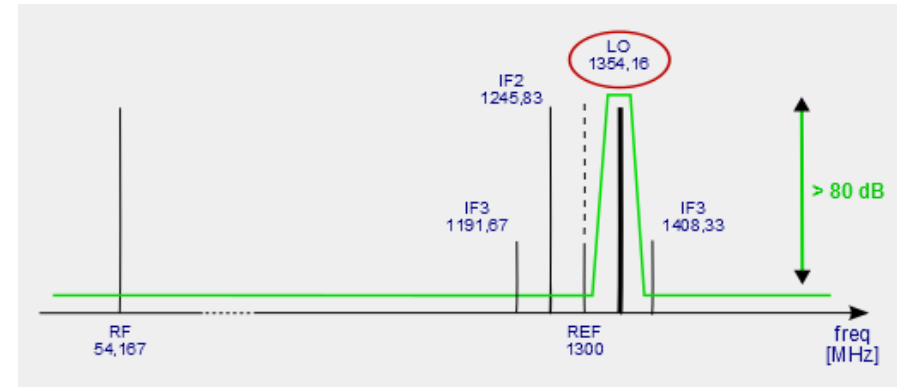
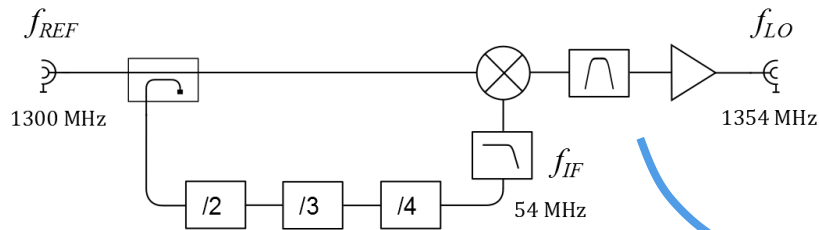

phase noise propagation model

$$|\Delta\varphi_{out}|^2 = \left[\left[\frac{|\Delta\varphi_{REF}|^2}{M_1^2} + |\Delta\varphi_{D1}|^2 \right] \cdot \frac{1}{M_2^2} + |\Delta\varphi_{D2}|^2 \right] \cdot \frac{1}{M_3^2} + |\Delta\varphi_{D3}|^2 + |\Delta\varphi_{MIX}|^2 + |\Delta\varphi_{AMP}|^2$$

Analysis

> Single-stage mixing

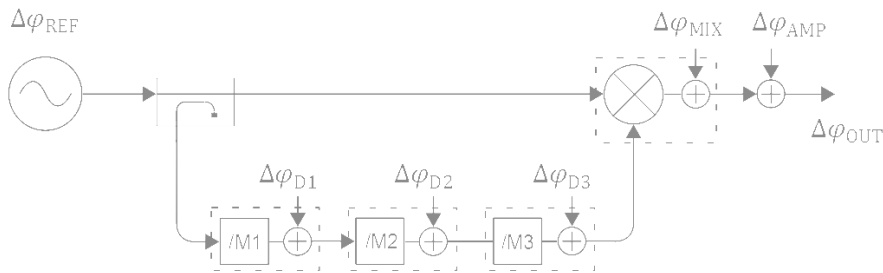
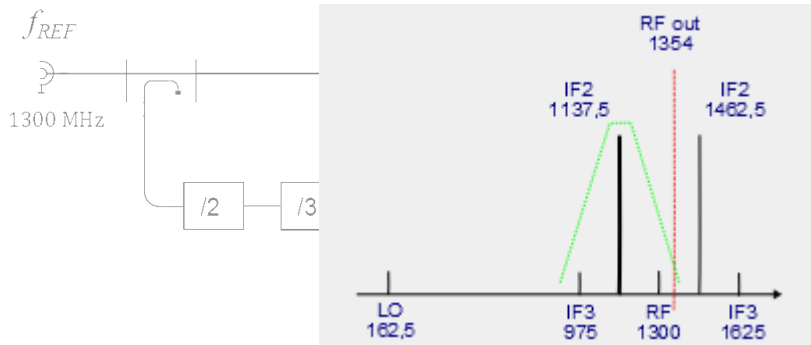

phase noise propagation model

$$|\Delta\varphi_{out}|^2 = \left[\left[\frac{|\Delta\varphi_{REF}|^2}{M_1^2} + |\Delta\varphi_{D1}|^2 \right] \cdot \frac{1}{M_2^2} + |\Delta\varphi_{D2}|^2 \right] \cdot \frac{1}{M_3^2} + |\Delta\varphi_{D3}|^2 + |\Delta\varphi_{MIX}|^2 + |\Delta\varphi_{AMP}|^2$$

> Double-stage mixing

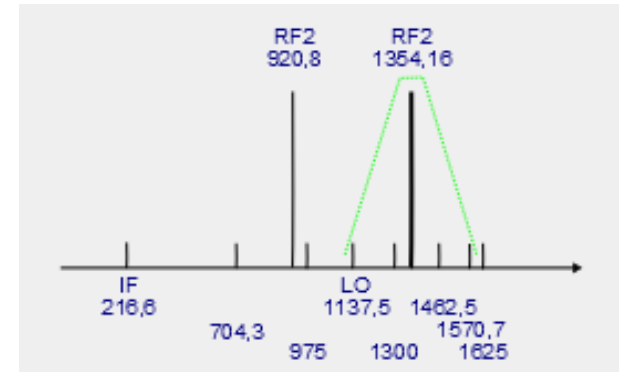
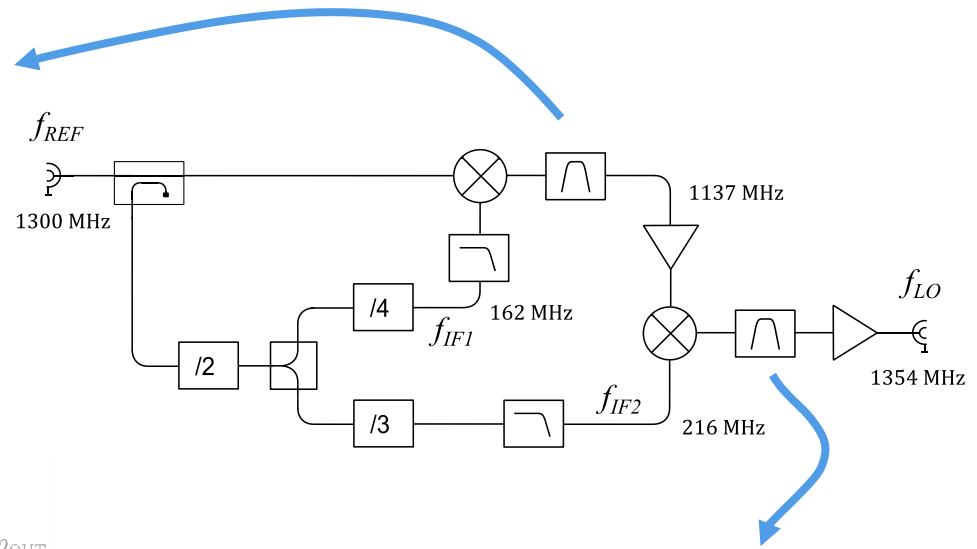

Prototyping

> Single-stage mixing

> Double-stage mixing

Residual phase noise measurements (2DUT phase detector method)

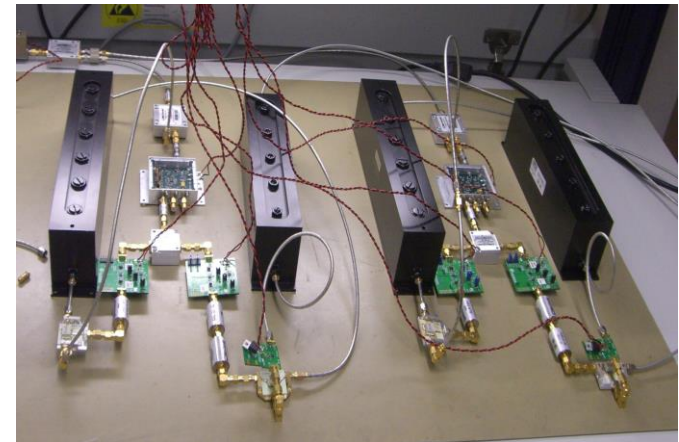
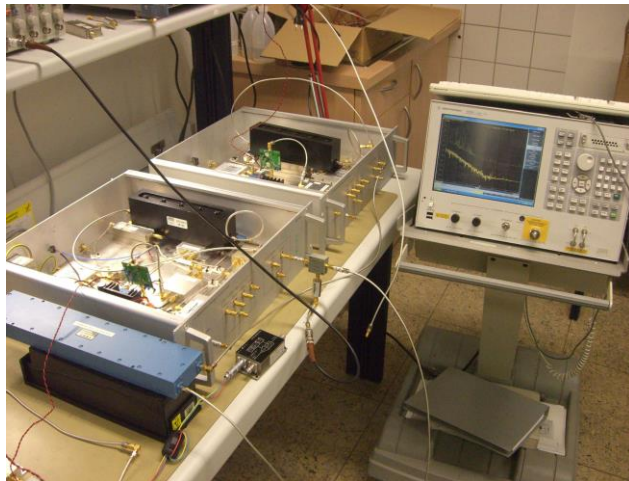
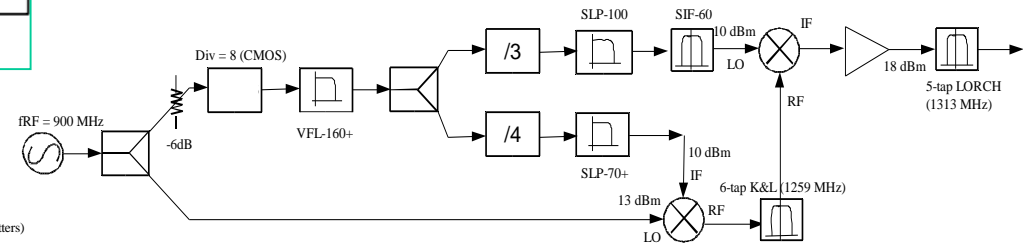
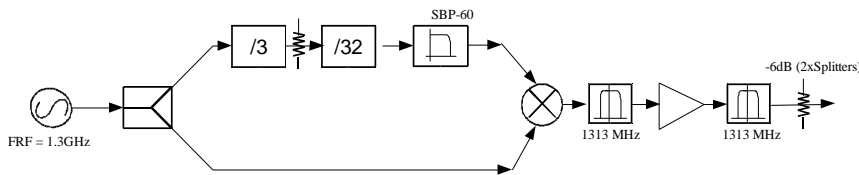
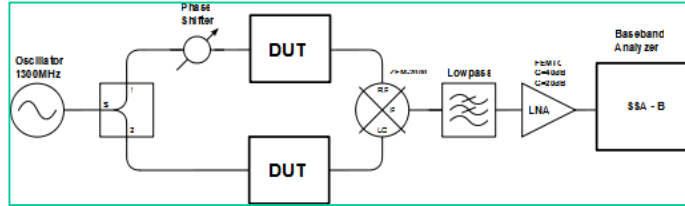

> LO residual RMS phase noise measurements and jitter calculations

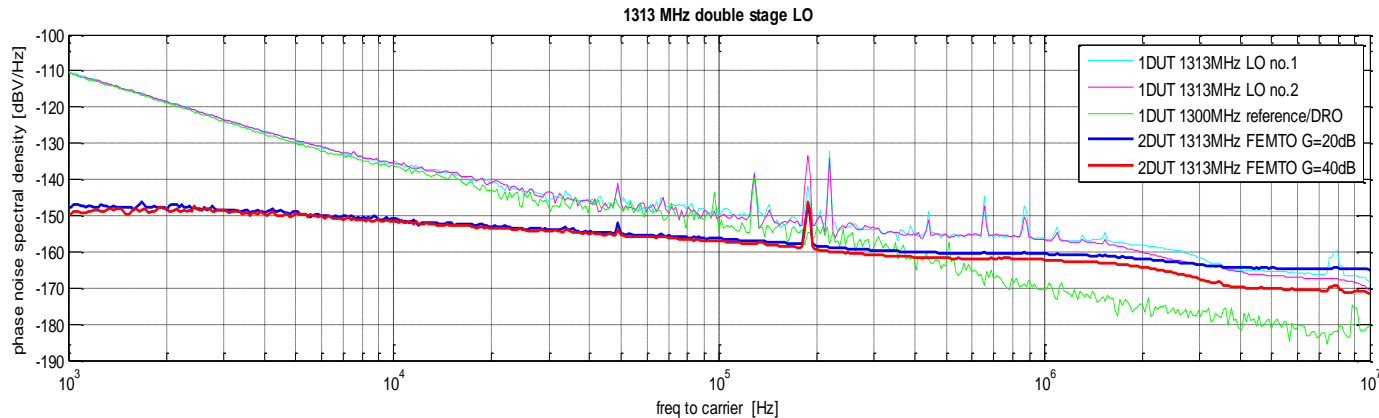

LO 1313 MHz	single-stage	double-stage
jitter 10 Hz – 1 MHz	2.6 fs (1.2 mdeg)	3.4 fs (1.6 mdeg)
Cross-check meas. jitter 1 kHz – 10 MHz	2.6 fs (1.2 mdeg)	2.8 fs (1.3 mdeg)

> Compact high-quality ceramic filters available !



> Single-mixer LO synthesis for final implementation

Final design

➤ Block diagram of the LOGM module

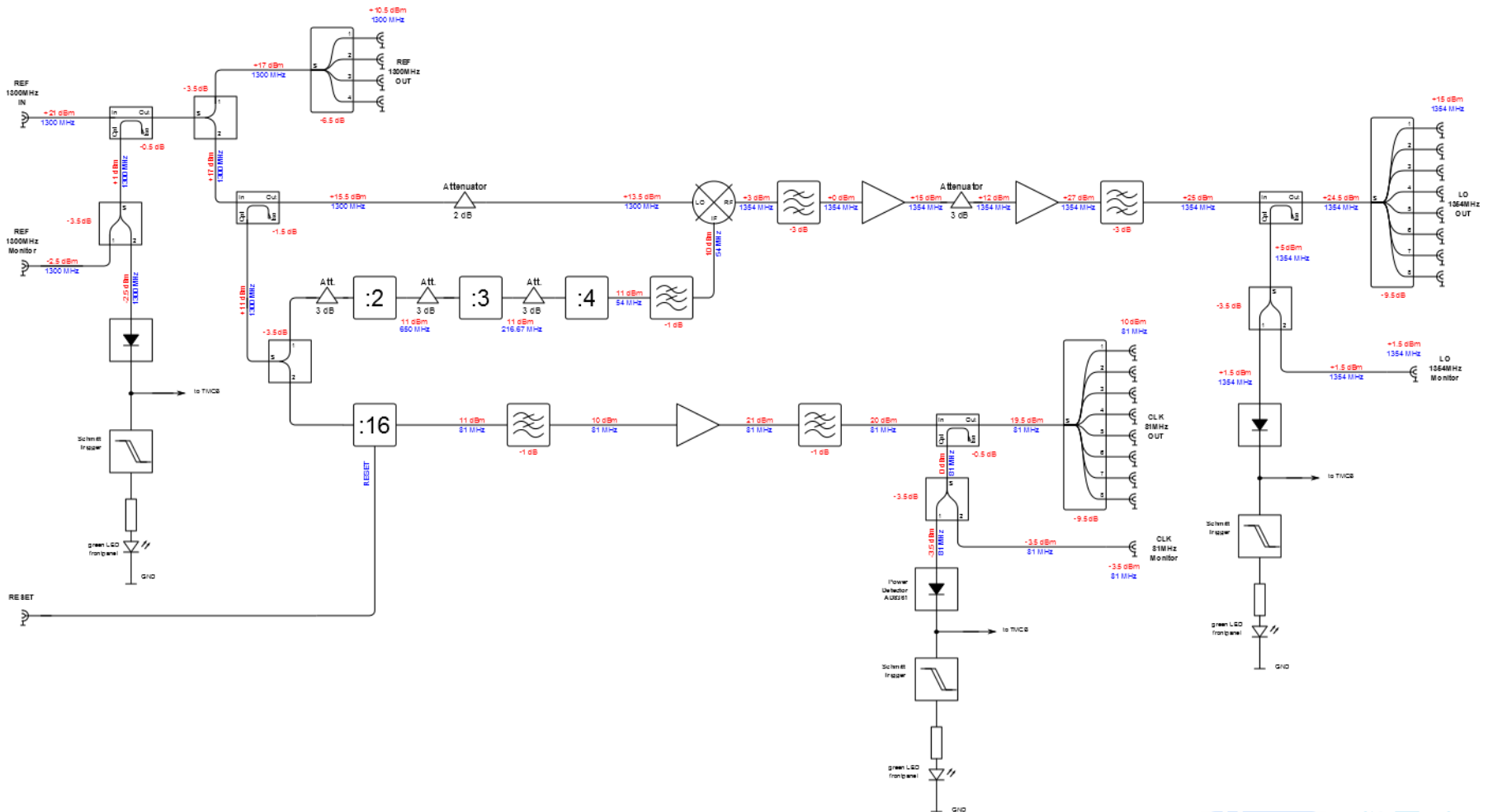

Final design

➤ PCB layout of LOGM

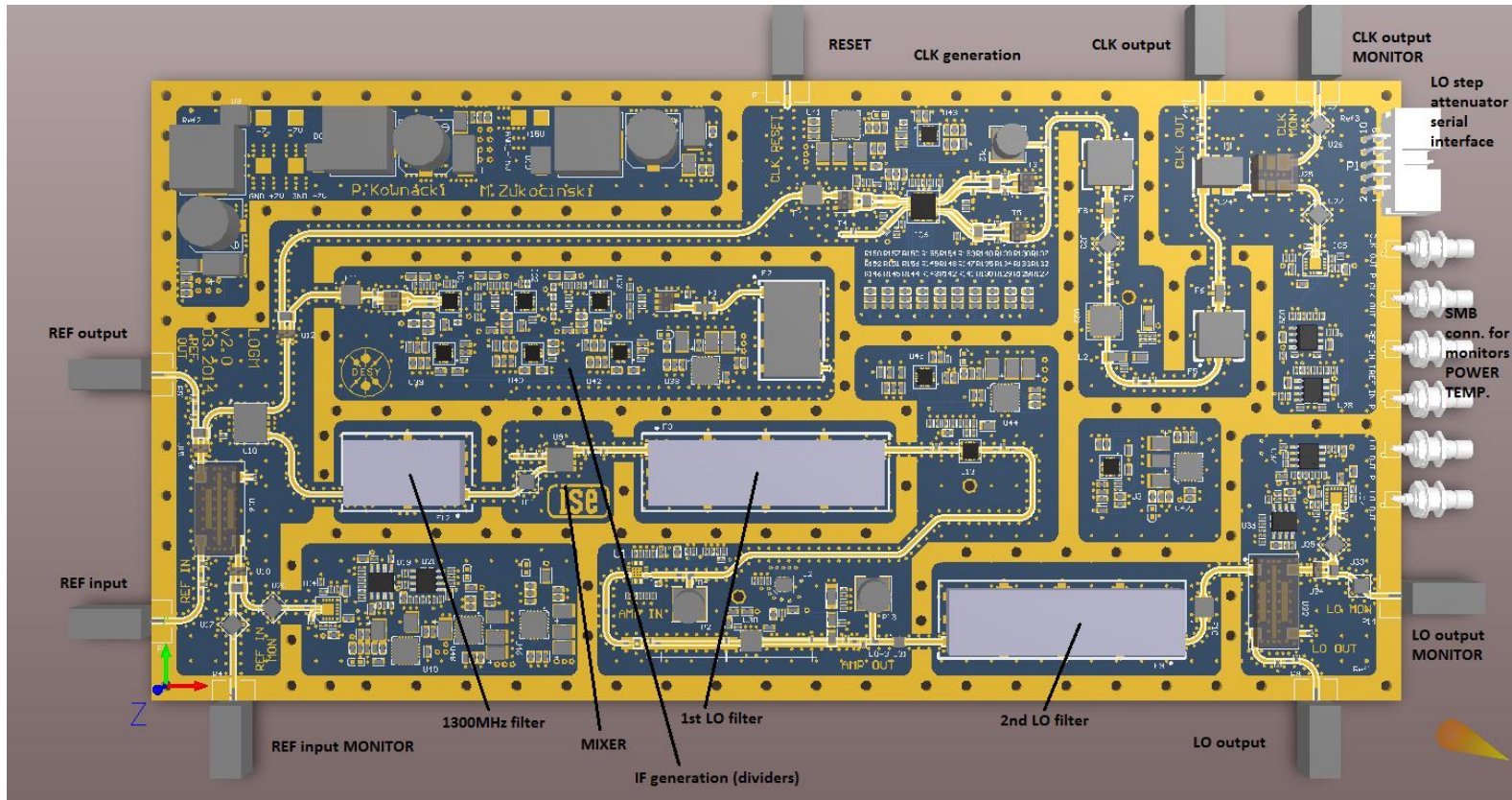

Final design

➤ LOGM module (PCB + metal case)

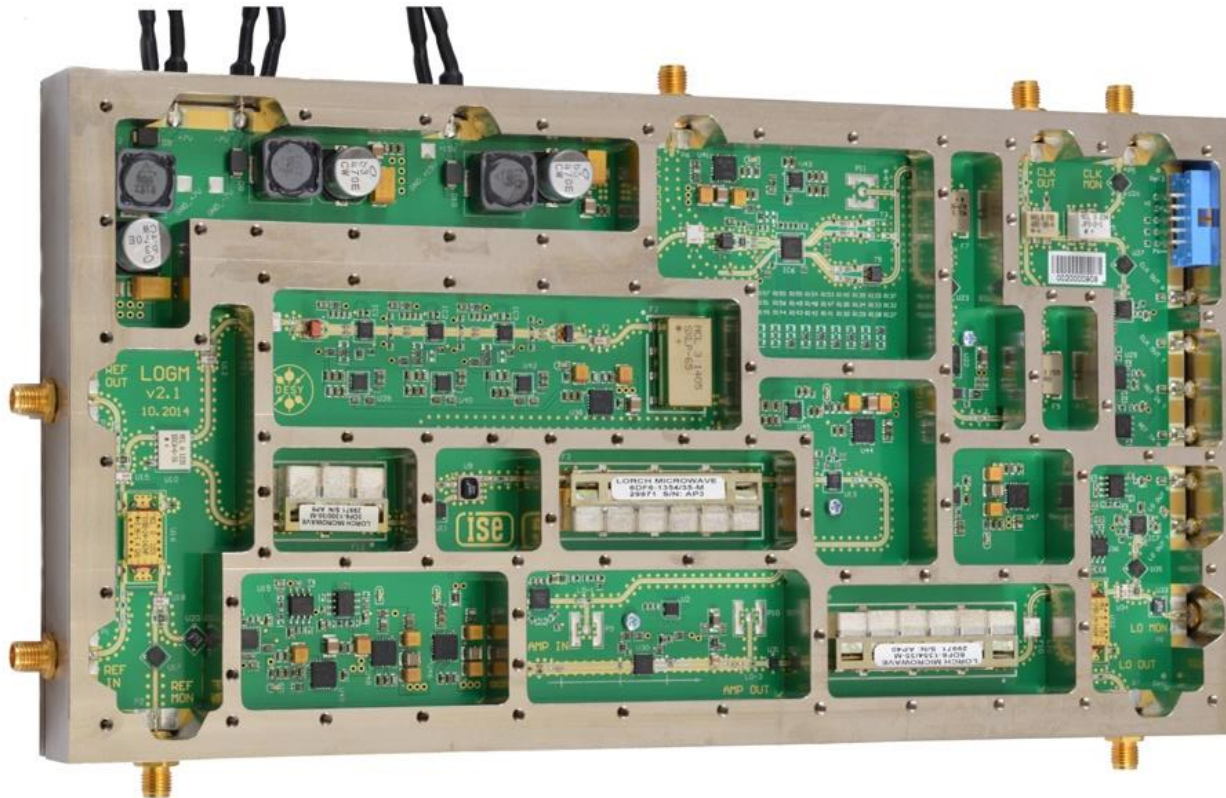

- Metal casing for improved EMI/EMC
- Reduced conductive crosstalk and radiative couplings (SFR >80 dBc)
- Efficient heat dissipation

Final design

- LOGM 19" crate – 3D mechanical modeling (crate integration)

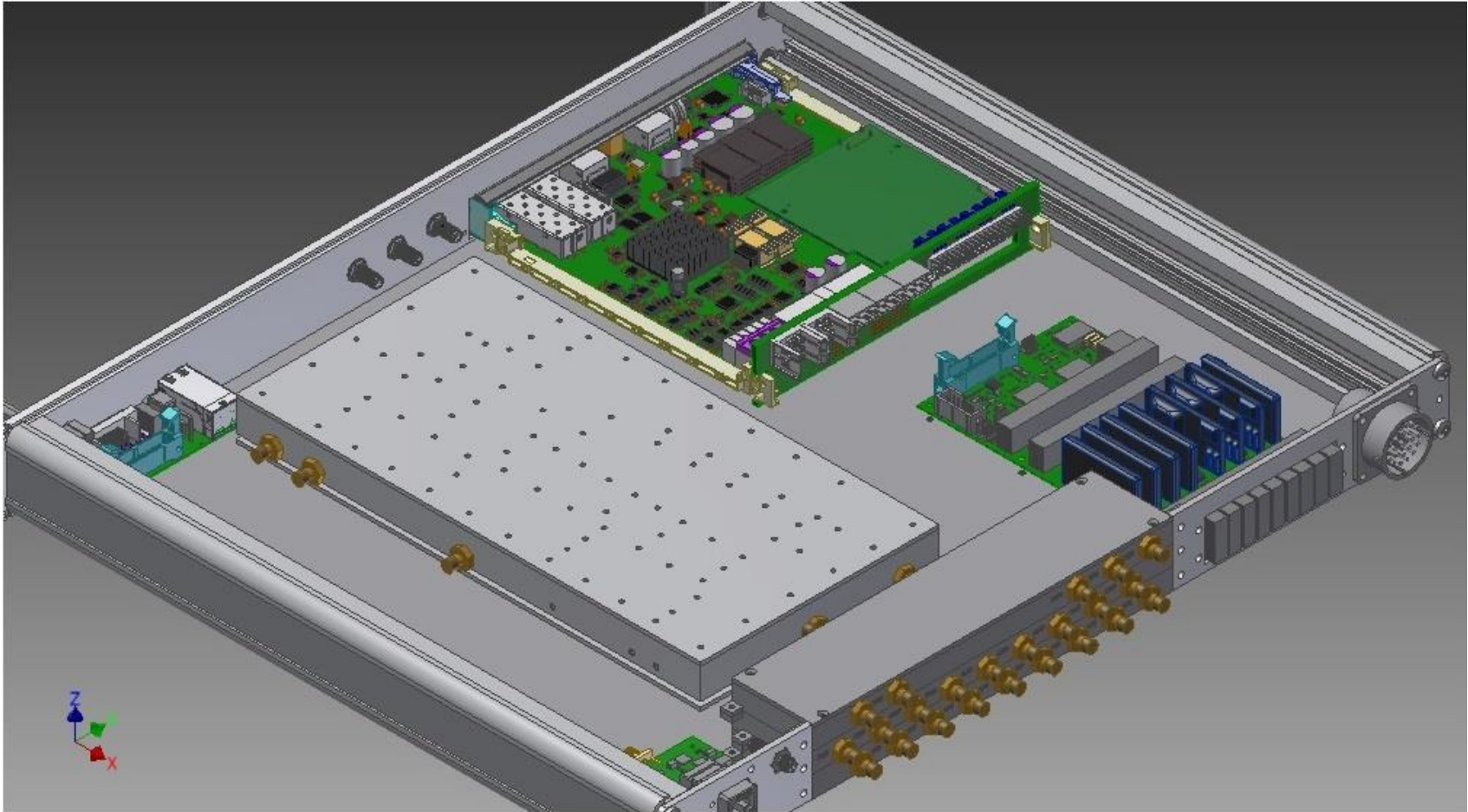

Final design

- LOGM 19" crate – 3D mechanical modeling (crate integration)

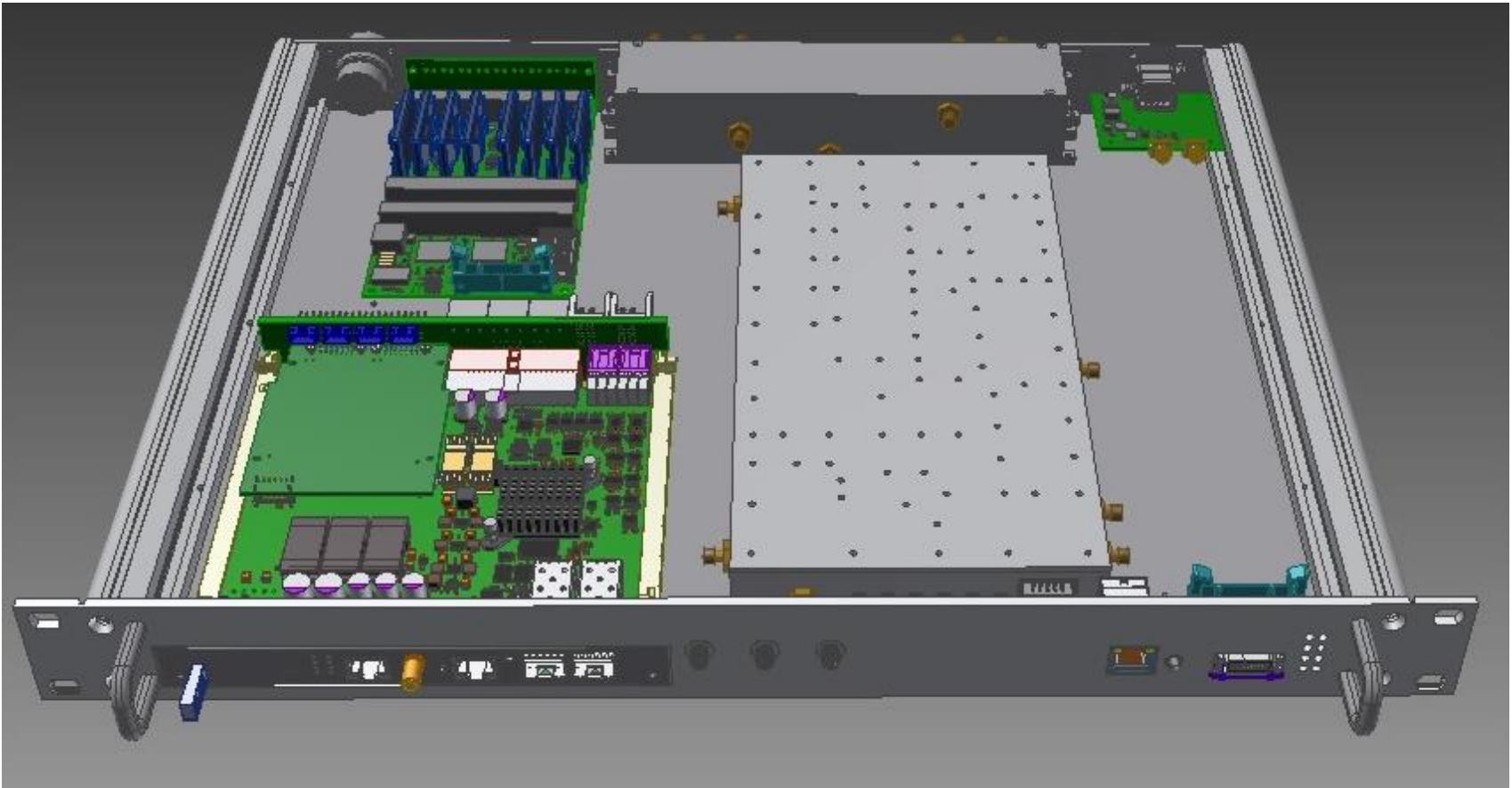

Final design

> LOGM 19" crate – internal arrangement

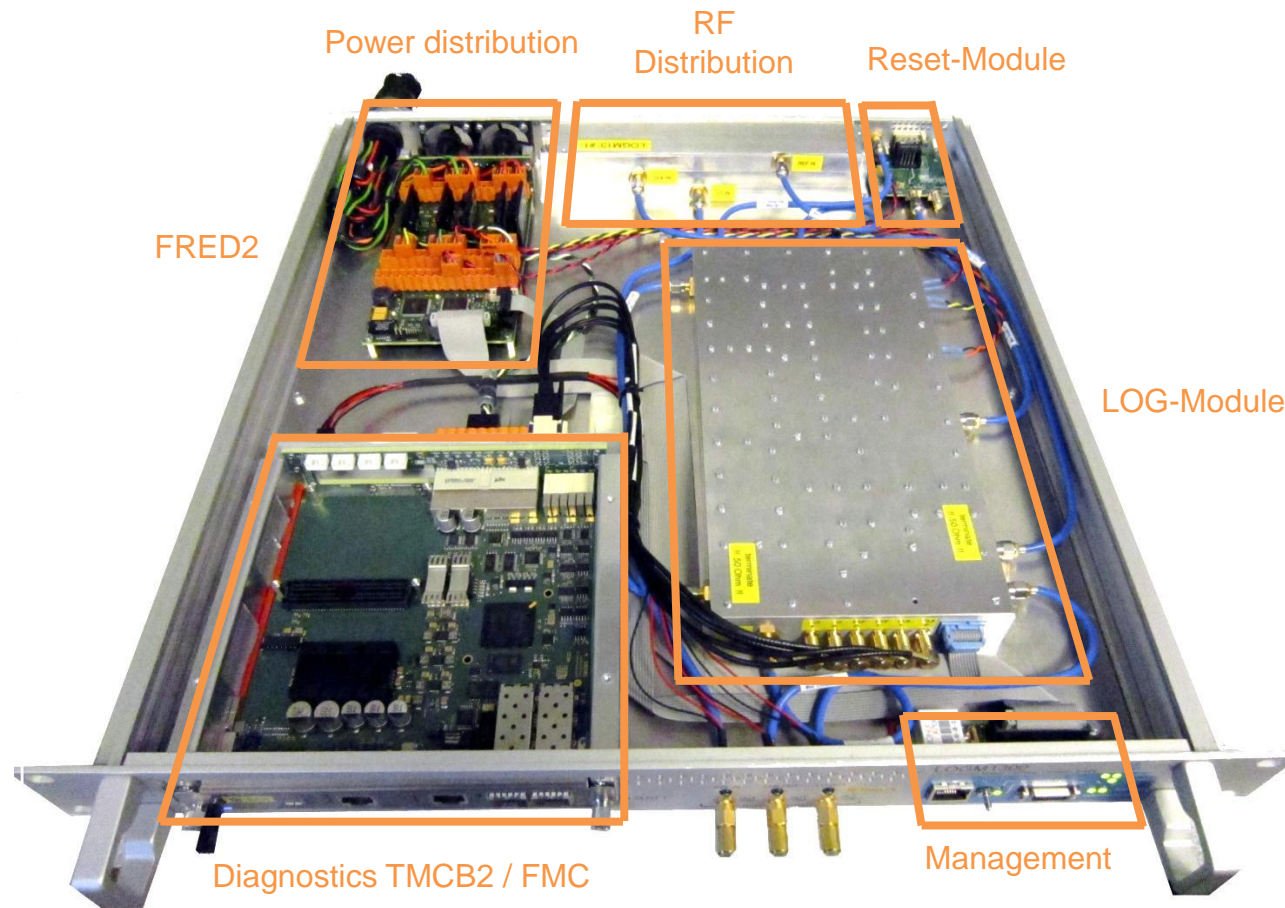

Final design

➤ LOGM 19" crate



Final design

> LOGM 19" crate

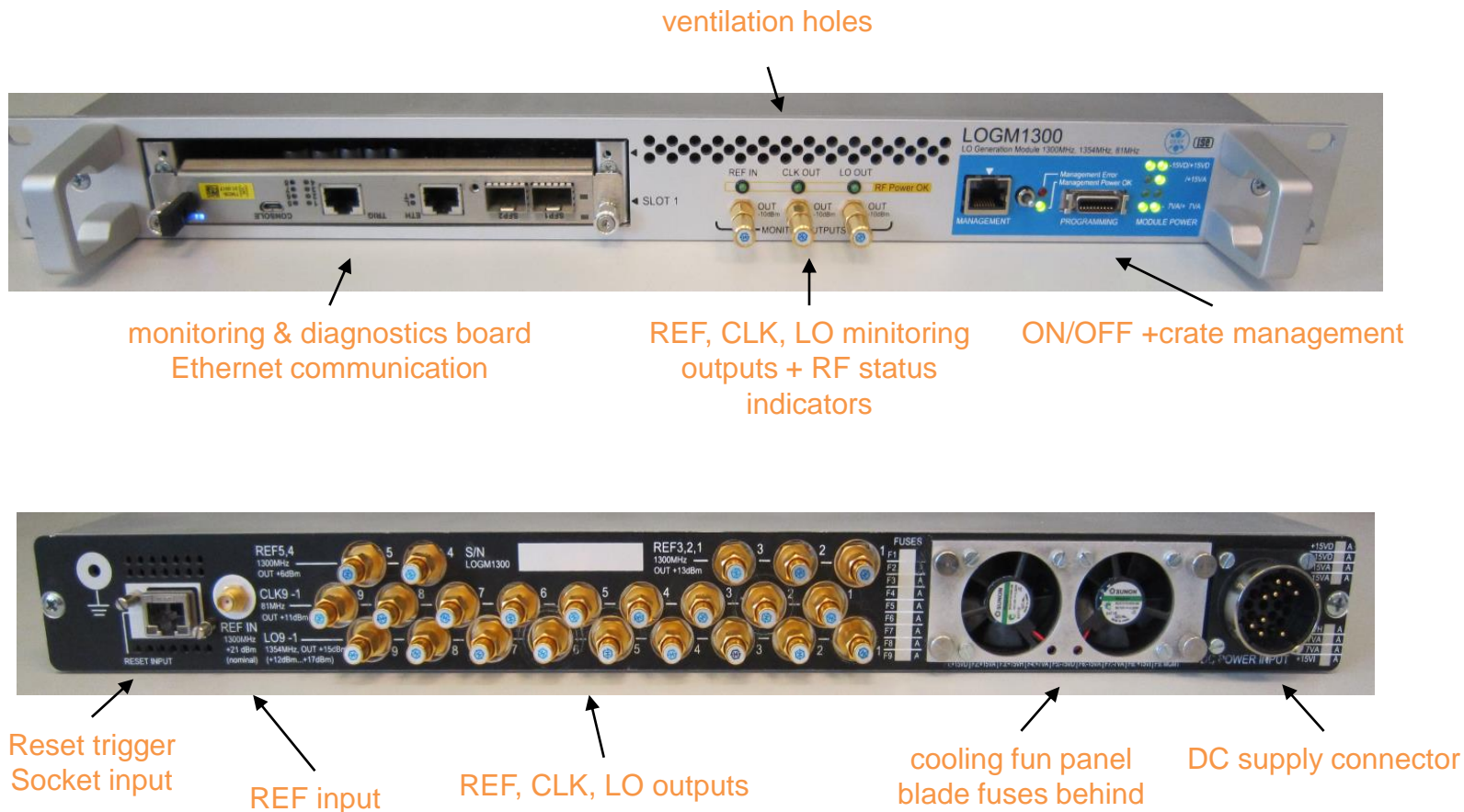

Final design

> LOGM 19" crate in the XFEL LLRF system

■ XFEL 48-channel LLRF station:

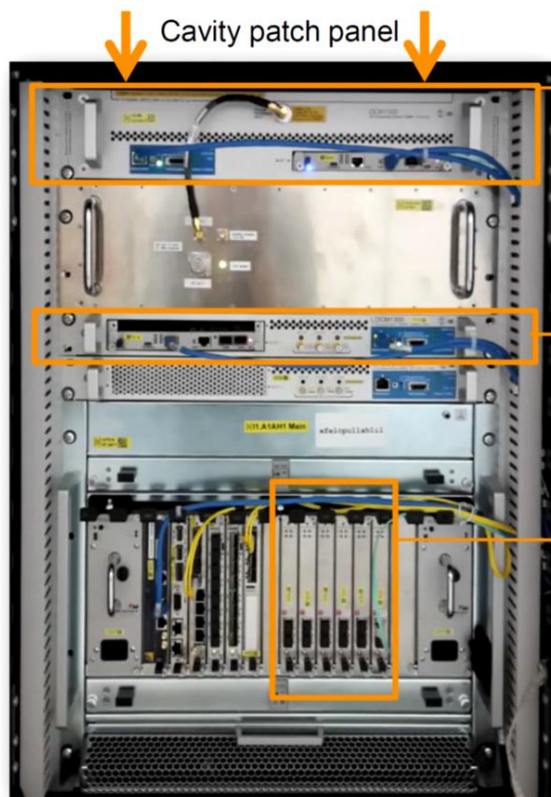

■ Sub-components and signal-flow: (standard non-iq sampling scheme)

Drift Compensation	DCM	2U 19" Module
LO-Generation	LOGM	1U 19" Module
Down-Converter	DWC	RTM MicroTCA.4
Low-noise Digitizer	ADC	AMC MicroTCA.4

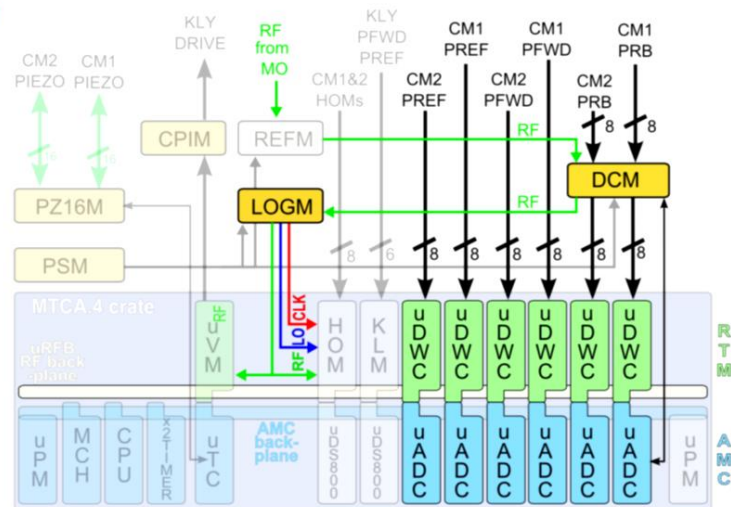

courtesy of Frank Ludwig, LLRF Workshop 2015, Shanghai

Results

REF spectrum

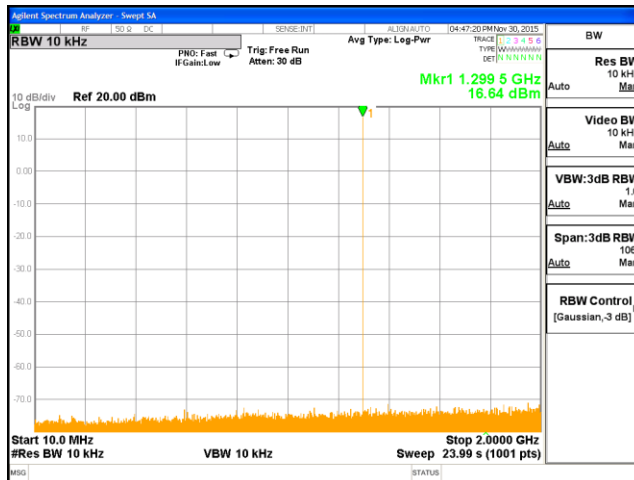

LO spectrum

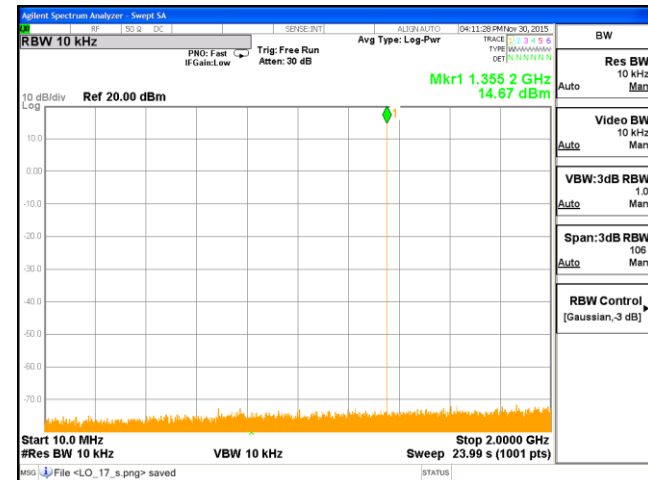

CLK spectrum

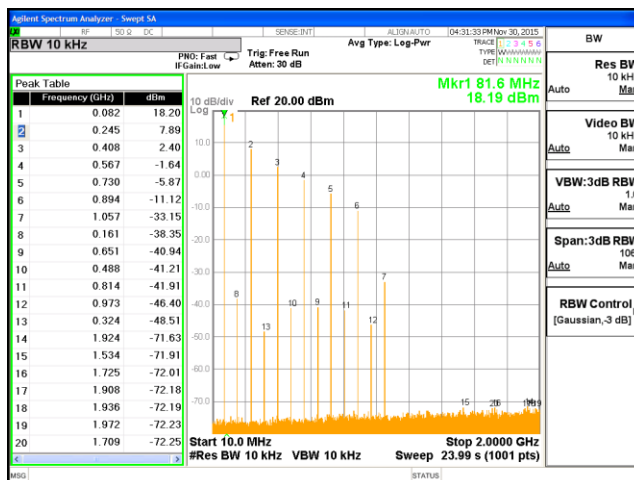

- Clean spectrum
- Spurious-free-range >80 dBc
- CLK bandwidth up to 1 GHz

Results

LO absolute phase noise spectrum

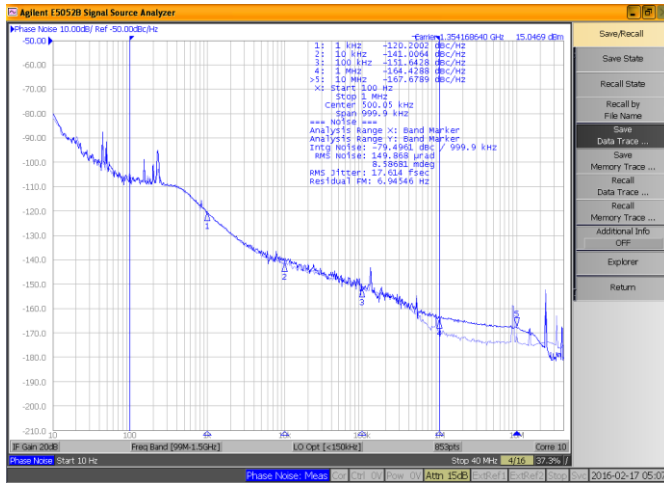

CLK absolute phase noise spectrum

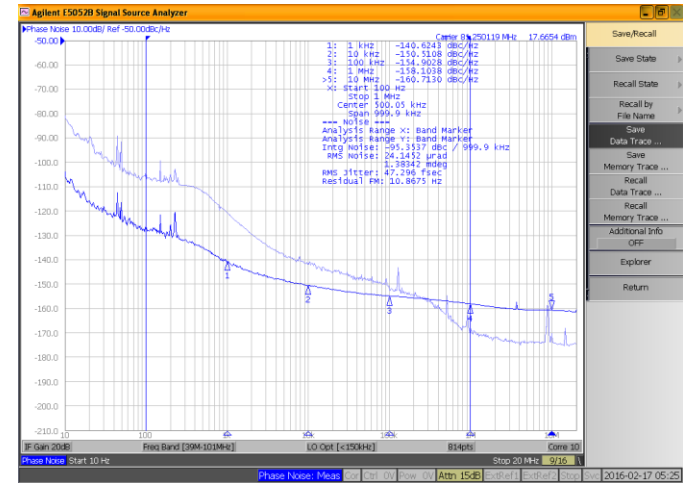

LO amplitude noise spectrum

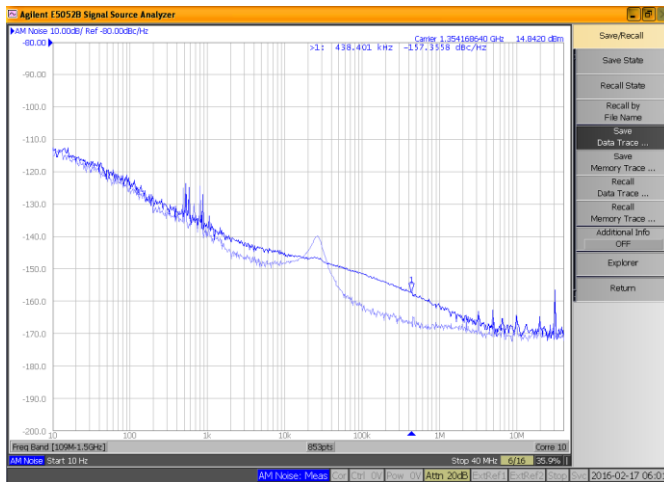

> Noise floor
< -160 dBc/Hz

CLK amplitude noise spectrum

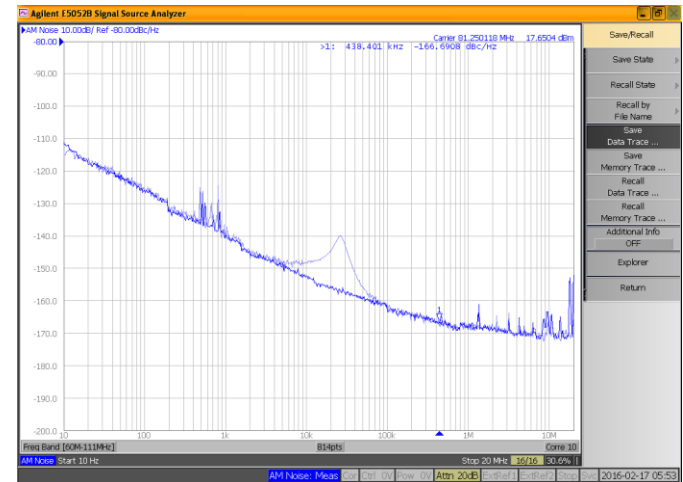

➤ Residual phase noise and jitter

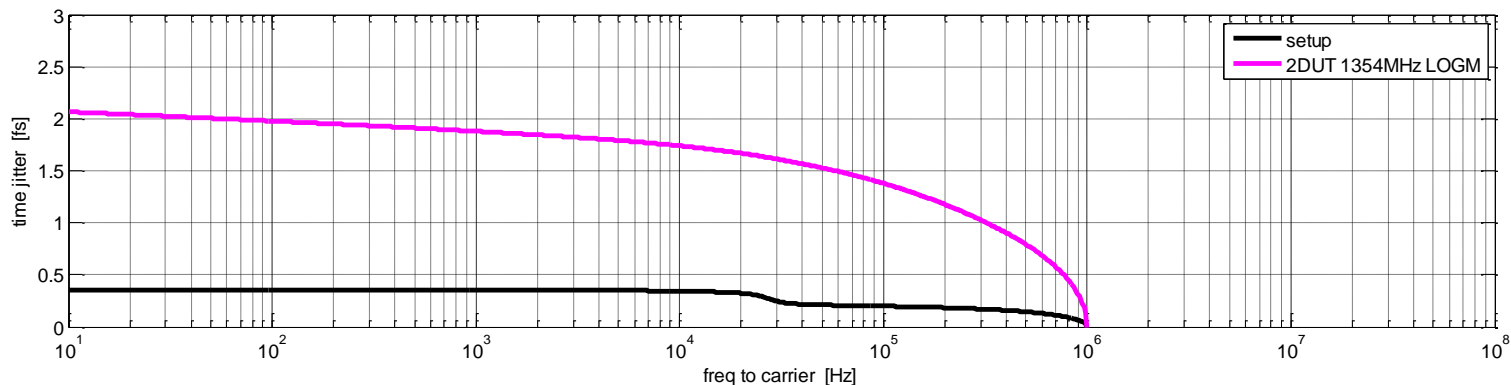
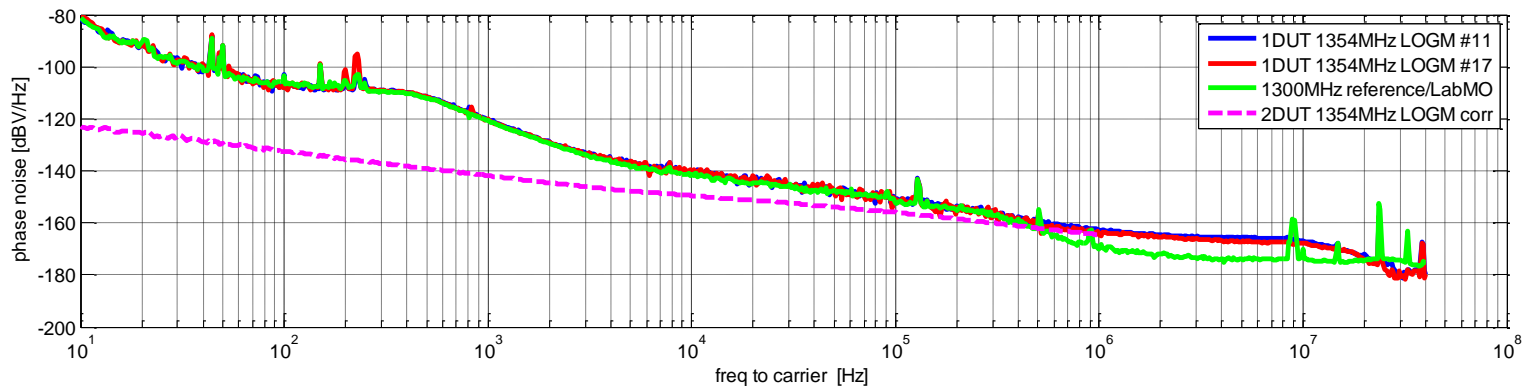

➤ RMS time jitter ~2 fs [10 Hz – 1 MHz]

Summary

- > Mixing technique useful for ultra-low phase noise LO generation
- > High performance LO and CLK generation module for European XFEL was developed
 - LO: ~ 2 fs of RMS time jitter [10 Hz - 1 MHz]
 - LO: < -160 dBc/Hz noise floor
 - spurious-free-range > 80 dBc
- > Motivation for spin-off projects:
 - DRTM-LOG1300 highly compact RTM module for MTCA.4
(poster on Tuesday by Tony Rohlev)
 - Universal LO&CLK generation module for LO [300 MHz – 6 GHz]
(poster on Wednesday by M. Żukociński)

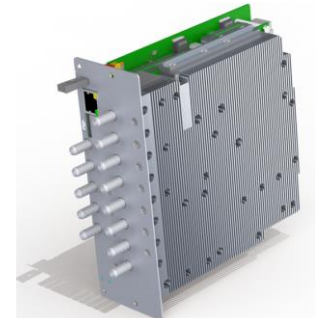

Thank you for your attention !