

---

# DARK MATTER SEARCHES AT ACCELERATORS

*Jonathan Feng, UC Irvine*

UCLA Dark Matter 2023, 29 March 2023



SIMONS  
FOUNDATION



HEISING-SIMONS  
FOUNDATION



# INTRODUCTION

---

- “Dark Matter Searches at Accelerators”: why should our experiments on Earth have any hope of telling us about what the universe looks like a Gpc away?

Accelerators  
Particle Physics  
 $L \sim 10^{-18}$  m

Dark Matter  
Cosmology  
 $L \sim 10^{25}$  m

- In fact, one of the wonders of our field is that there are reasons for optimism.
  - The existence of dark matter is now one of the strongest reasons to expect not only that new particles exists, but also that new particles will appear at the particle experiments we are now building.
  - General arguments have motivated a huge number of new ideas for experiments at accelerators and colliders in the coming years.
  - DM is now a leading motivation for accelerator experiments. This was not always the case...

# DARK MATTER AT THE LHC

1990's



2000's



Now



# ACCELERATOR SEARCHES FOR DM

---

- Disadvantages
  - Can't probe DM masses above the COM energy (can't use the enormous energy of the early universe as your collider).
  - Can't prove particles are sufficiently long-lived; must extrapolate from  $\tau \sim 10^{-7}$  s to  $\tau \sim 10^{17}$  s.
  - Can't prove that the particle seen is actually (a component of) DM – always need complementarity to establish the DM connection.
- Advantages
  - Can produce DM with very high intensities, not limited by  $\rho \sim 0.3$  GeV/cm<sup>3</sup>.
  - Can produce DM with high velocities and energies, not limited by  $E \sim \frac{1}{2}mv^2$ , with  $v \sim 10^{-3}$ . No “low mass threshold.”
  - Can control the source; e.g., if you see a signal, can turn the beam off to measure backgrounds.
  - **DM provides a thermal relic target for searches.**

# THE THERMAL RELIC LANDSCAPE

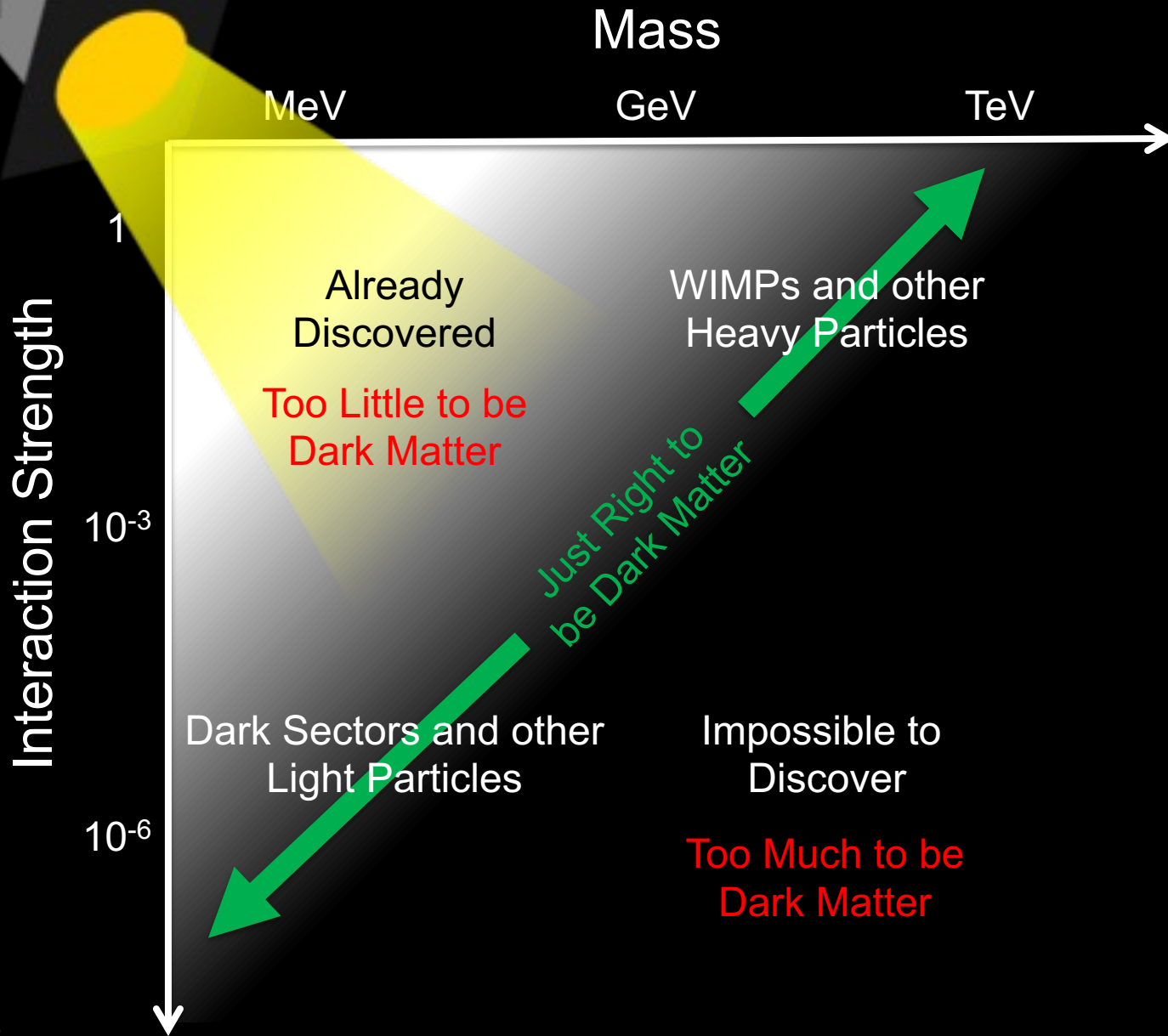

# THERMAL RELIC CAVEATS

- Thermal relic targets rely on assumptions
  - We don't know that much about very early cosmology
  - There are other ways to produce dark matter
  - Even within the thermal freeze out framework, there are “loopholes”
- Still, no one likes a bottomless pit, and in a world of uncertainty, thermal relic targets provide a welcome guidepost to what parts of parameter space are of special interest.

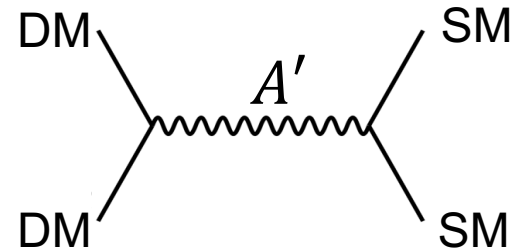

$$\epsilon_R \approx (m_{A'} - 2m_{DM}) / m_{A'}$$

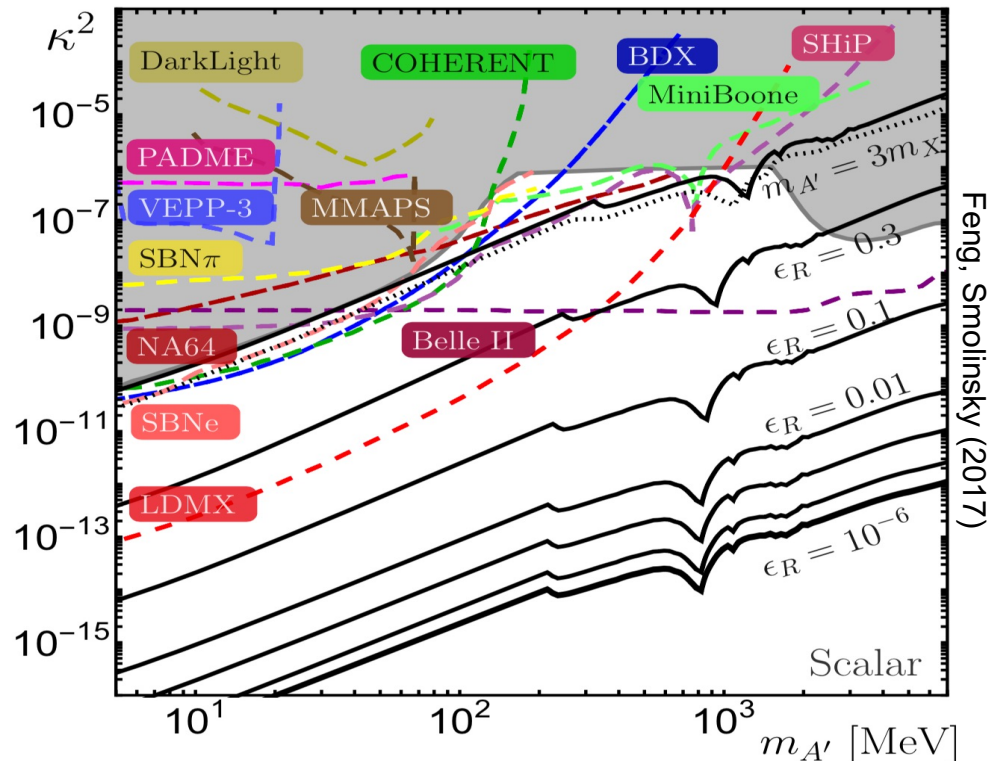

# HEAVY DM: WIMPS

- WIMPs are heavy, so the LHC is the primary source of the strongest constraints.
- The LHC is a postdoc by year, but a kindergartner by luminosity.
- Run 3 started July-November 2022 at 13.6 TeV, continues through 2025.
- High-Luminosity LHC is from ~2028-40.
- Many, many searches; most do not yet include Run 3 data.

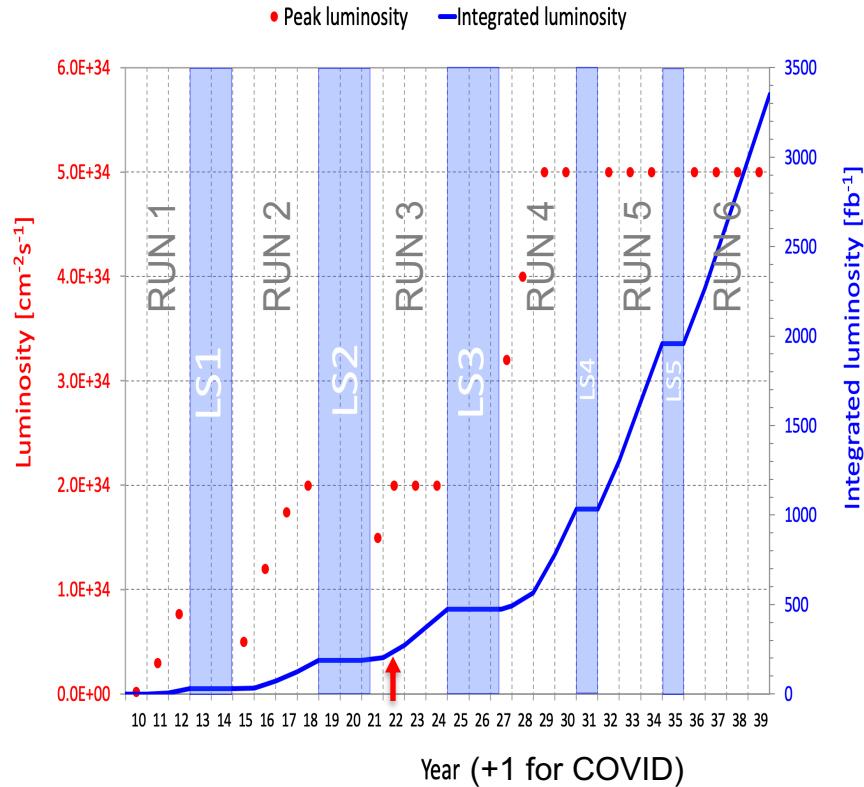

ATLAS SUSY Searches\* - 95% CL Lower Limits  
March 2023

ATLAS Preliminary  
 $\sqrt{s} = 13 \text{ TeV}$

| Model                                   | Signature   | $[L \cdot d] (\text{fb}^{-1})$                                | Mass limit | Reference   |
|---|---|---|------------|---|
| Inclusive Searches                      | $0. c.u.$ monojet   | $2-6 \text{ jets } E_{T}^{\text{miss}}$ 139                   | $1.8$ 1.85 | $m(\tilde{L}) < 40 \text{ GeV}$<br>$m(\tilde{W}) < 5 \text{ GeV}$                         |
|   | $2\tilde{L}, \tilde{L} \rightarrow \text{qq}$   | $1-3 \text{ jets } E_{T}^{\text{miss}}$ 139                   | 0.9        | 2102.10874  |
|   | $0. c.u.$ $2-6 \text{ jets } E_{T}^{\text{miss}}$   | $2-6 \text{ jets } E_{T}^{\text{miss}}$ 139                   | 1.15-1.95  | 2.3   |
|   | $1. c.u.$ $2-6 \text{ jets } E_{T}^{\text{miss}}$   | $2-6 \text{ jets } E_{T}^{\text{miss}}$ 139                   | Forbidden  | $m(\tilde{L}) < 100 \text{ GeV}$  |
|   | $2\tilde{L}, \tilde{L} \rightarrow \text{qq} W^0$   | $2 \text{ jets } E_{T}^{\text{miss}}$ 139                     | 2.2        | $m(\tilde{L}) < 80 \text{ GeV}$   |
|   | $2\tilde{L}, \tilde{L} \rightarrow \text{qq} W^{\pm}$                                       | $2 \text{ jets } E_{T}^{\text{miss}}$ 139                     | 2.2        | $m(\tilde{L}) < 100 \text{ GeV}$  |
|   | $0. c.u.$ $7-11 \text{ jets } E_{T}^{\text{miss}}$  | $7-11 \text{ jets } E_{T}^{\text{miss}}$ 139                  | 1.97       | $m(\tilde{L}) < 80 \text{ GeV}$   |
|   | $2\tilde{L}, \tilde{L} \rightarrow \text{qq} W^0 Z$   | $6 \text{ jets } E_{T}^{\text{miss}}$ 139                     | 1.15       | $m(\tilde{L}) < 200 \text{ GeV}$  |
|   | $0.1 c.u.$ $3 \text{ b } E_{T}^{\text{miss}}$   | $3 \text{ b } E_{T}^{\text{miss}}$ 139                        | 1.25       | $m(\tilde{L}) < 50 \text{ GeV}$   |
|   | $SS, c.u.$ $6 \text{ jets } E_{T}^{\text{miss}}$  | $6 \text{ jets } E_{T}^{\text{miss}}$ 139                     | 2.45       | $m(\tilde{L}) < 50 \text{ GeV}$<br>$m(\tilde{W}) < 5 \text{ GeV}$                         |
| $3^{rd}$ gen. squarks direct production | $b\bar{b}$  | $0. c.u.$ $2 \text{ b } E_{T}^{\text{miss}}$ 139              | 1.235      | $m(\tilde{L}) < 40 \text{ GeV}$<br>$10 \text{ GeV} < m(\tilde{L}) < 20 \text{ GeV}$       |
|   | $\tilde{b}_1, \tilde{b}_1 \rightarrow b\bar{b} \rightarrow b\bar{b} \rightarrow b\bar{b}$   | $6 \text{ b } E_{T}^{\text{miss}}$ 139                        | Forbidden  | $10 \text{ GeV} < m(\tilde{L}) < 100 \text{ GeV}$<br>$m(\tilde{L}) < 100 \text{ GeV}$     |
|   | $2 \text{ t } E_{T}^{\text{miss}}$  | $2 \text{ t } E_{T}^{\text{miss}}$ 139                        | 0.13-0.85  | $2.23-1.35$   |
|   | $0-1 c.u.$ $\geq 1 \text{ jet } E_{T}^{\text{miss}}$  | $\geq 1 \text{ jet } E_{T}^{\text{miss}}$ 139                 | 1.25       | $m(\tilde{L}) < 100 \text{ GeV}$  |
|   | $1. c.u.$ $3 \text{ jets } 1 \text{ b } E_{T}^{\text{miss}}$                                | $3 \text{ jets } 1 \text{ b } E_{T}^{\text{miss}}$ 139        | Forbidden  | $m(\tilde{L}) < 500 \text{ GeV}$  |
|   | $1.2 c.u.$ $2 \text{ jets } 1 \text{ b } E_{T}^{\text{miss}}$                               | $2 \text{ jets } 1 \text{ b } E_{T}^{\text{miss}}$ 139        | Forbidden  | $m(\tilde{L}) < 80 \text{ GeV}$   |
|   | $0. c.u.$ $2 \text{ t } E_{T}^{\text{miss}}$  | $2 \text{ t } E_{T}^{\text{miss}}$ 361                        | 0.55       | 0.85  |
|   | $0. c.u.$ monojet $E_{T}^{\text{miss}}$   | $\text{monojet } E_{T}^{\text{miss}}$ 139                     | 0.55       | $m(\tilde{L}) < 54 \text{ GeV}$   |
|   | $1.2 c.u.$ $1-4 \text{ b } E_{T}^{\text{miss}}$   | $1-4 \text{ b } E_{T}^{\text{miss}}$ 139                      | 0.067-1.18 | $m(\tilde{L}) < 500 \text{ GeV}$  |
|   | $3 c.u.$ $1 \text{ b } E_{T}^{\text{miss}}$   | $1 \text{ b } E_{T}^{\text{miss}}$ 139                        | Forbidden  | $m(\tilde{L}) < 300 \text{ GeV}$<br>$m(\tilde{W}) < 40 \text{ GeV}$                       |
| EW direct                               | $\tilde{L}\tilde{L}^* \rightarrow WZ$   | Multiple $0 \text{ jets } E_{T}^{\text{miss}}$ 139            | $0.205$    | $m(\tilde{L}) < 40 \text{ GeV}$ , who-bino<br>$m(\tilde{L}) < 5 \text{ GeV}$ , who-bino   |
|   | $\tilde{L}\tilde{L}^* \rightarrow WW$   | $2 c.u.$ $2 \text{ b } E_{T}^{\text{miss}}$ 139               | 0.42       | 1.96  |
|   | $\tilde{L}\tilde{L}^* \rightarrow W\tilde{L}$   | Multiple $0 \text{ jets } E_{T}^{\text{miss}}$ 139            | Forbidden  | $m(\tilde{L}) < 70 \text{ GeV}$ , who-bino<br>$m(\tilde{L}) < 200 \text{ GeV}$ , who-bino |
|   | $\tilde{L}\tilde{L}^* \rightarrow W\tilde{L}^*$   | $2 c.u.$ $2 \text{ b } E_{T}^{\text{miss}}$ 139               | 0.19-0.3   | 0.12-0.39   |
|   | $\tilde{L}\tilde{L}^* \rightarrow W\tilde{L}^* \tilde{L}$                                   | $2 \text{ t } E_{T}^{\text{miss}}$ 139                        | 0.256      | 0.7   |
|   | $\tilde{L}\tilde{L}^* \rightarrow W\tilde{L}^* \tilde{L}^*$                                 | $2 c.u.$ $0 \text{ jets } E_{T}^{\text{miss}}$ 139            | 0.13-0.23  | 0.29-0.68   |
|   | $\tilde{L}\tilde{L}^* \rightarrow W\tilde{L}^* \tilde{L}^* \tilde{L}$                       | $0. c.u.$ $\geq 3 \text{ b } E_{T}^{\text{miss}}$ 139         | 0.55       | 0.45-0.93   |
|   | $\tilde{L}\tilde{L}^* \rightarrow W\tilde{L}^* \tilde{L}^* \tilde{L}^*$                     | $4 c.u.$ $0 \text{ jets } E_{T}^{\text{miss}}$ 139            | 0.77       | 0.77  |
|   | $\tilde{L}\tilde{L}^* \rightarrow W\tilde{L}^* \tilde{L}^* \tilde{L}^* \tilde{L}$           | $2 c.u.$ $\geq 2 \text{ large jets } E_{T}^{\text{miss}}$ 139 | 0.55       | 0.45-0.93   |
|   | $\tilde{L}\tilde{L}^* \rightarrow W\tilde{L}^* \tilde{L}^* \tilde{L}^* \tilde{L}^*$         | $2 c.u.$ $\geq 2 \text{ jets } E_{T}^{\text{miss}}$ 139       | 0.77       | 0.77  |
| Long-lived particles                    | Direct $\tilde{L}\tilde{L}^* \rightarrow \text{prod. long-lived } \tilde{L}$                | Disapp. $0 \text{ jets } E_{T}^{\text{miss}}$ 139             | 0.21       | 0.66  |
|   | Stable $\tilde{L}$ Rhadron  | pixel dE/dx $E_{T}^{\text{miss}}$ 139                         | 2.05       | 2.05  |
| RPV                                     | $\tilde{L}\tilde{L}^* \rightarrow \tilde{L}\tilde{L}^* \rightarrow \text{prod. } \tilde{L}$ | $3 c.u.$ $0 \text{ jets } E_{T}^{\text{miss}}$ 139            | 0.625      | 1.05  |
|   | $\tilde{L}\tilde{L}^* \rightarrow \tilde{L}\tilde{L}^* \rightarrow \text{prod. } \tilde{L}$ | $4 c.u.$ $0 \text{ jets } E_{T}^{\text{miss}}$ 139            | 0.95       | 1.55  |

\*Only a selection of the available mass limits on new states or phenomena is shown. Many of the limits are based on simplified models, c.f. refs. for the assumptions made.

# SUSY WIMPS AT THE LHC

- Expect missing  $E_T$  signature. Consider SUSY.

See Baer and Heinemeyer talks

- If gluino pairs cascade decay to neutralino WIMPs, current bounds exclude gluinos  $\lesssim 2$  TeV, LSPs  $\lesssim 1$  TeV.
- If sleptons decay to neutralino WIMPs, current bounds exclude sleptons up to  $\sim 700$  GeV, LSPs  $\sim 300$  GeV, but bounds degrade with degeneracy (215 GeV for  $\Delta m = 5$  GeV).

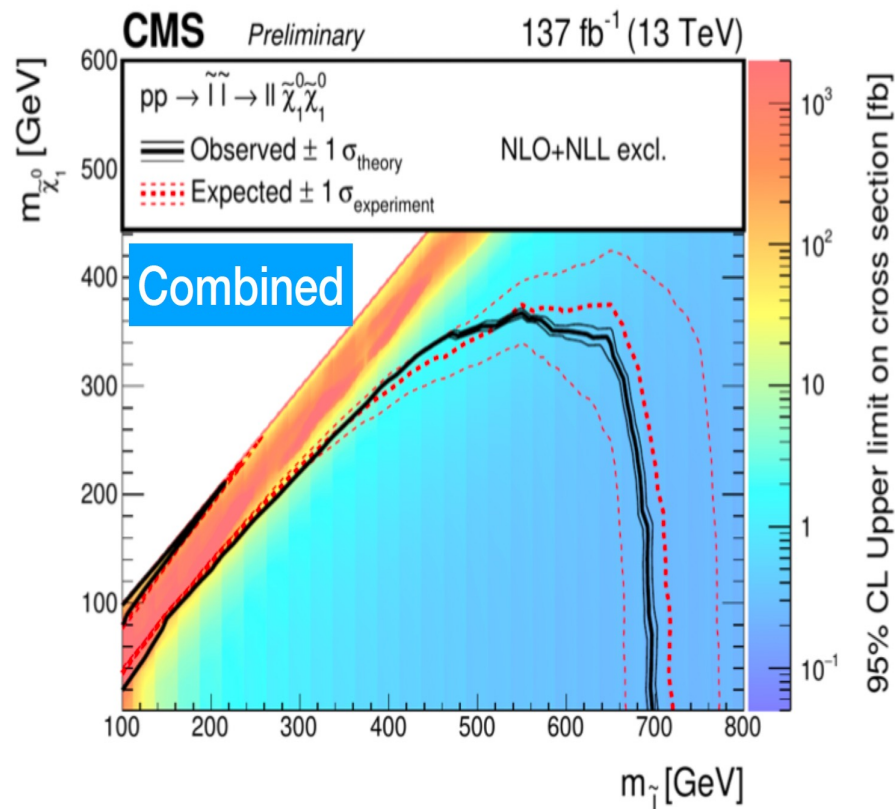
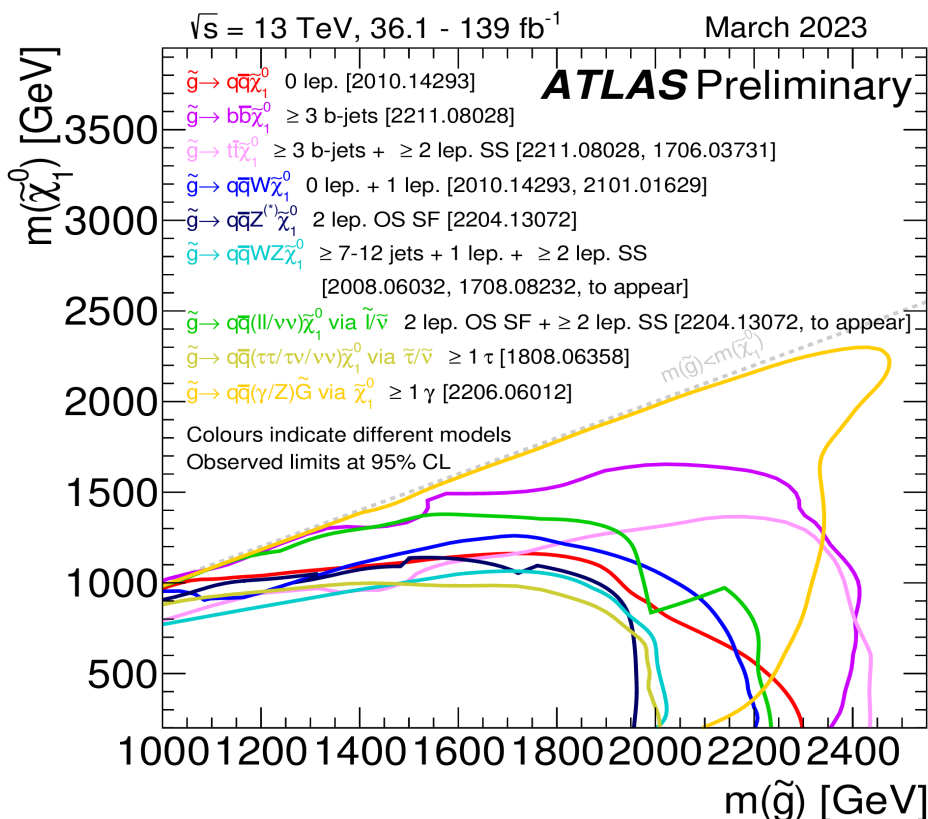



# LONG-LIVED PARTICLES AT THE LHC

- The search for DM at the LHC has broadened to include many other signatures beyond missing  $E_T$ .
- For example, NLSP  $\rightarrow$  gravitino DM can naturally have decay lengths from mm to km, lead to final state jets, leptons, or photons.

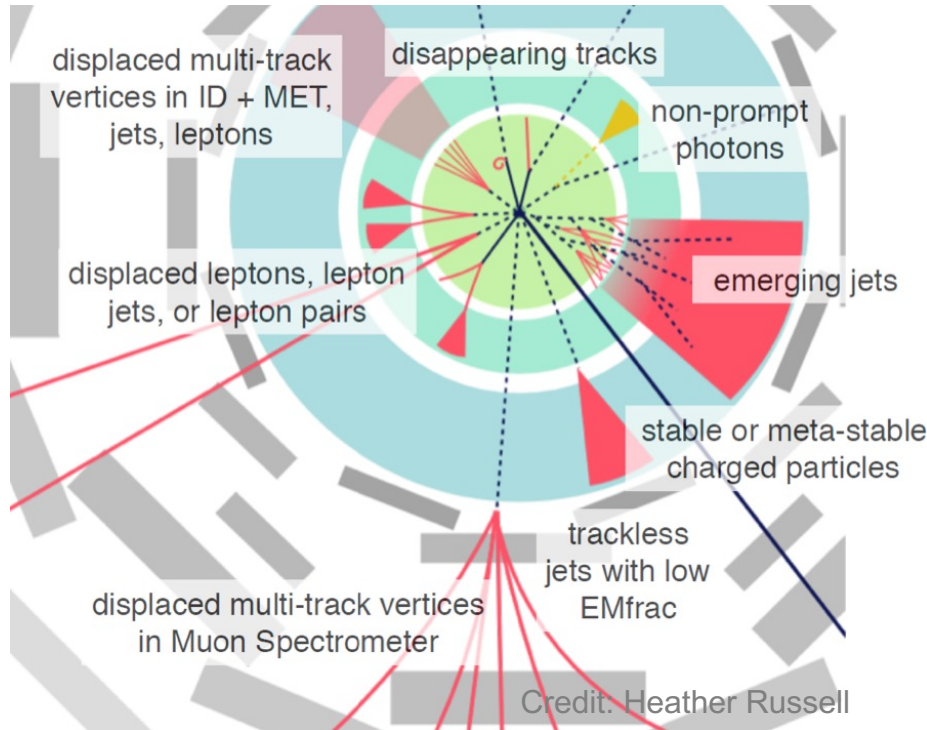

## Overview of CMS long-lived particle searches

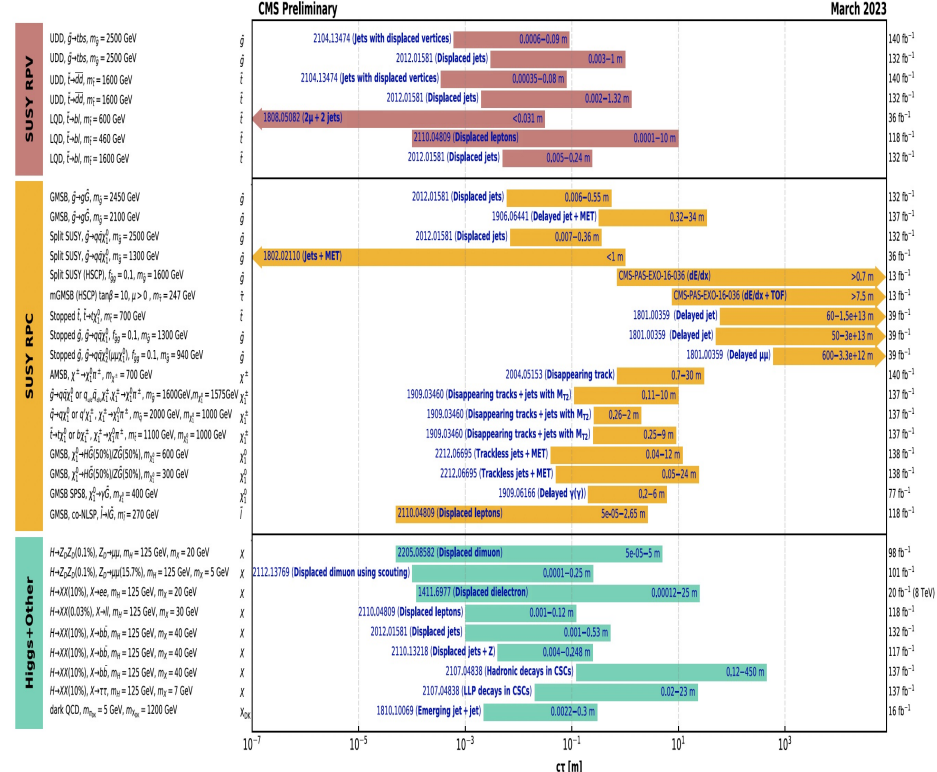

Selection of observed exclusion limits at 95% CL. (Theory uncertainties are not included). The y-axis tick labels indicate the studied long-lived particle.

# LIGHT DM: DARK SECTORS

- Dark sector particles from MeV to GeV can also be thermal relics.
- But, because they are light, there are an enormous number of past, current, and proposed accelerator experiments that can be relevant.

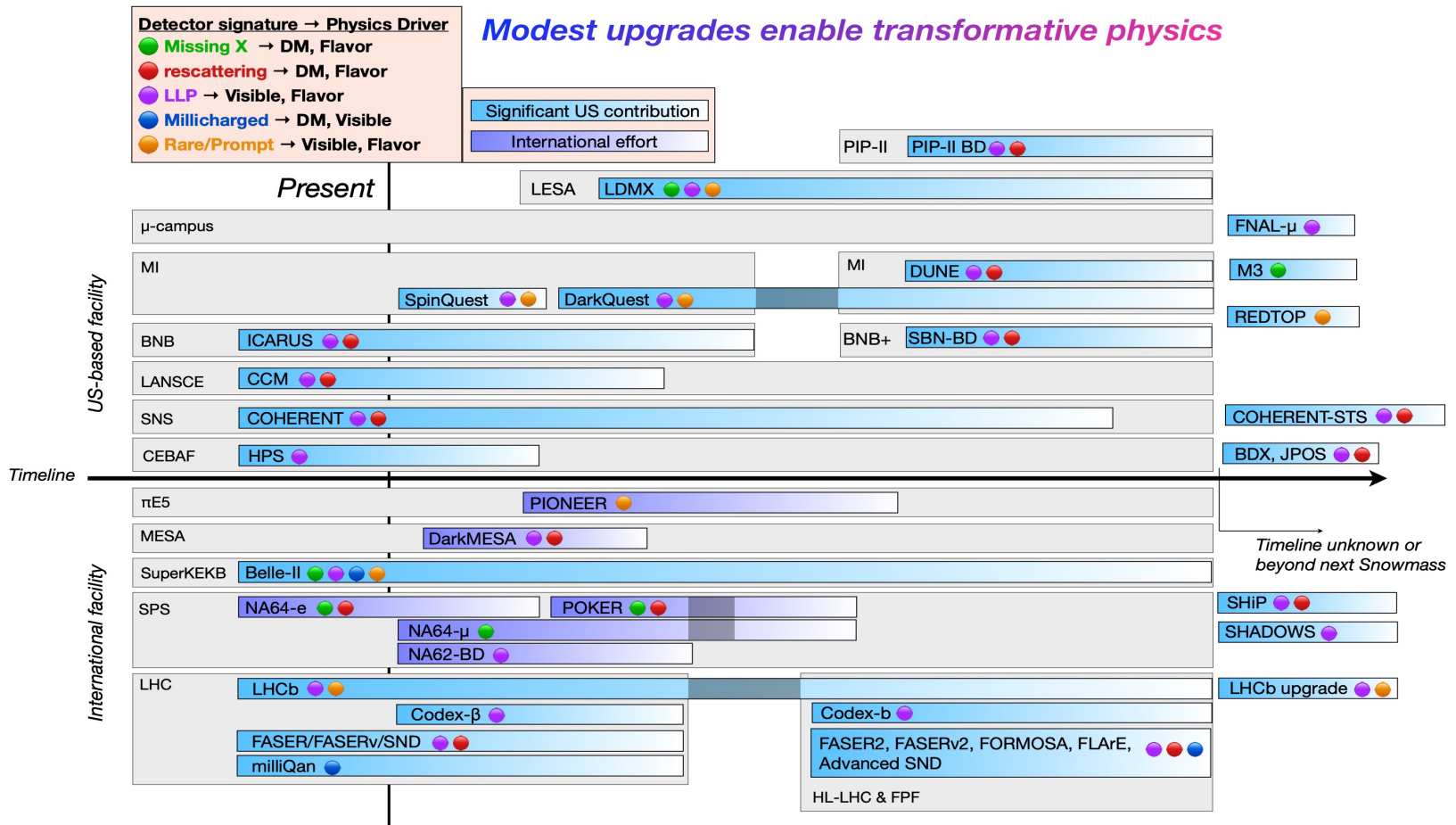

# DARK SECTOR BENCHMARKS

- Won't be able to even superficially cover all these, but will give some examples.
- Each of these experiments can be evaluated for its reach in various dark sector benchmark models. For example:
  - Dark photon with visible decays to SM particles:

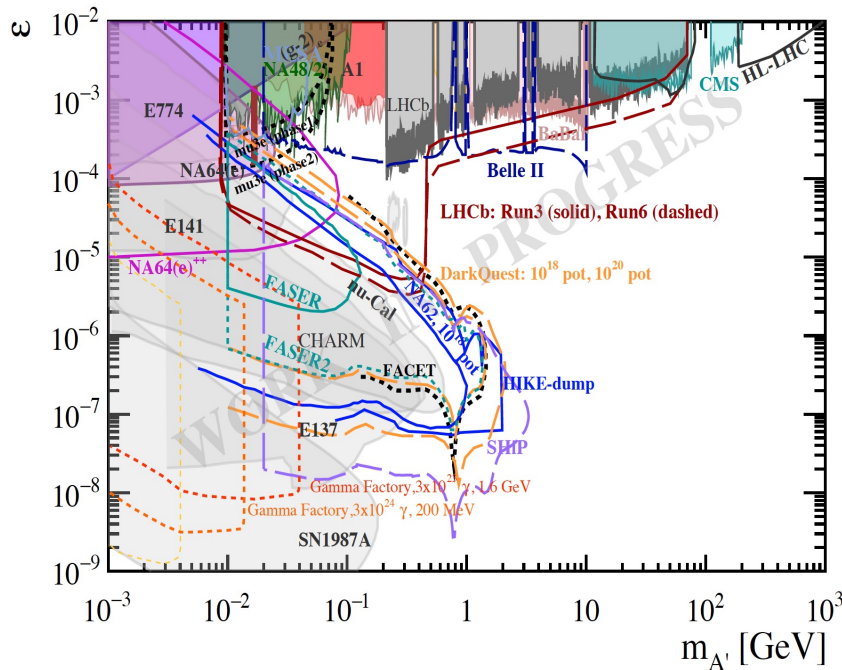

- Dark photon with invisible decays to dark sector particles:

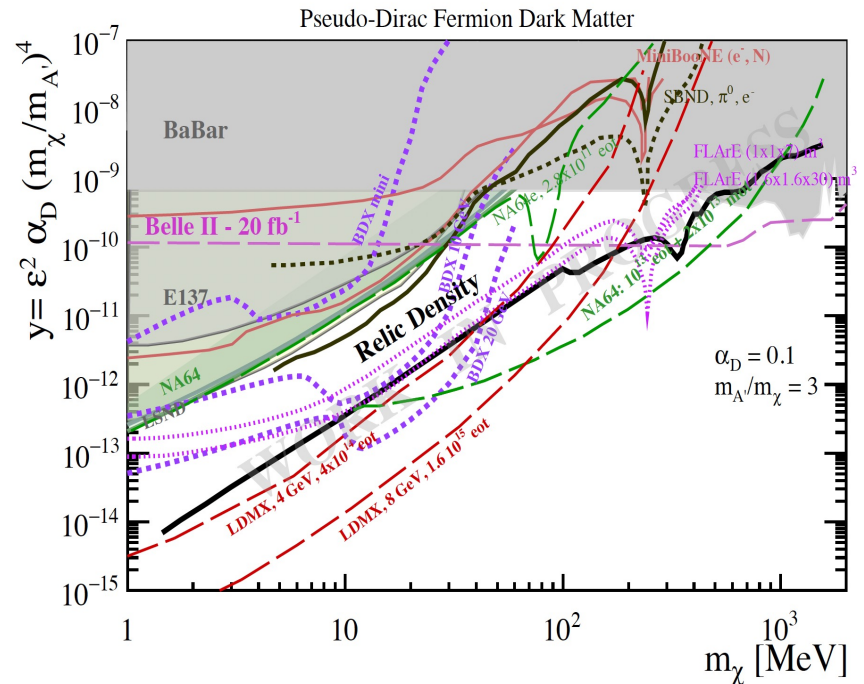

Lanfranchi, Pospelov et al., FIPs 2022 Workshop summary, in preparation

# SEARCHES AT HIGH COUPLING: BABAR AND BELLE II

- At "high" coupling, dark photons decay promptly.
- Sensitive searches from  $e^+e^-$  colliders with  $E_{\text{COM}} \sim 10$  GeV, extraordinary luminosity. BaBar at SLAC concluded, Belle II at KEK is ongoing, can look for either invisible or visible decay excess at various invariant masses.

- Dark photon with visible decays to SM particles:

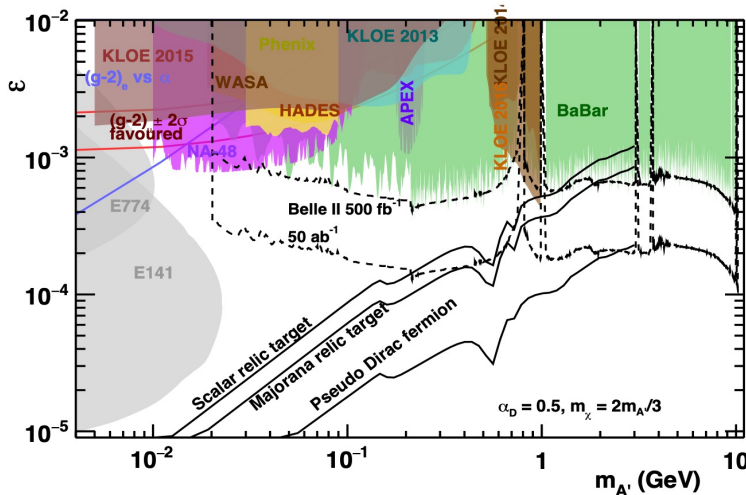
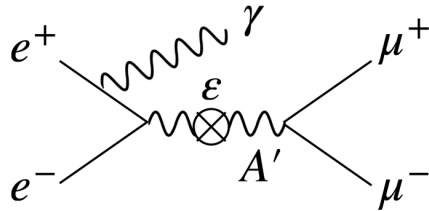

- Dark photon with invisible decays to dark sector particles:

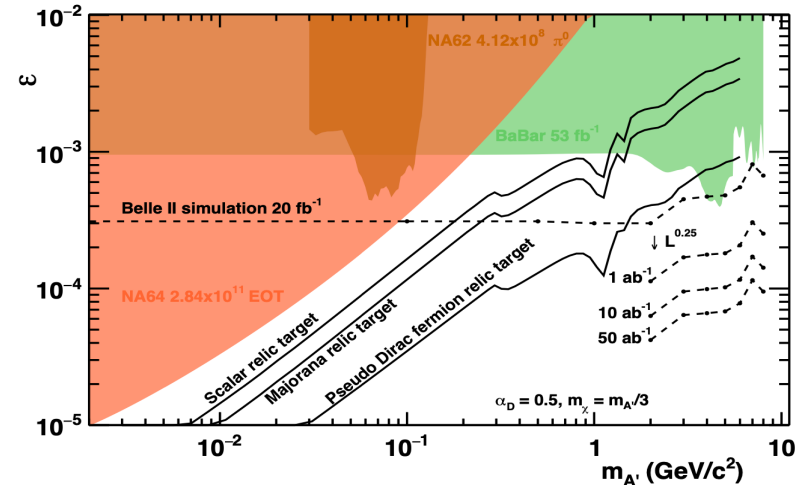
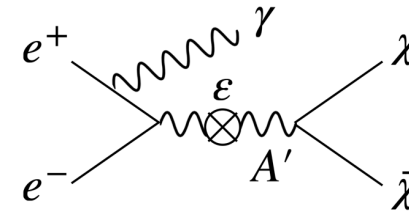

Hearty (2022)

See Robertson and Shuve talks

# SEARCHES FOR INVISIBLE DECAYS: NA64 AND LDMX

- Can look specifically for electrons recoiling from nuclei, search for missing energy/momentum/mass. DM interaction is not detected.

- NA64 is an ongoing electron beam dump experiment at the SPS at CERN.

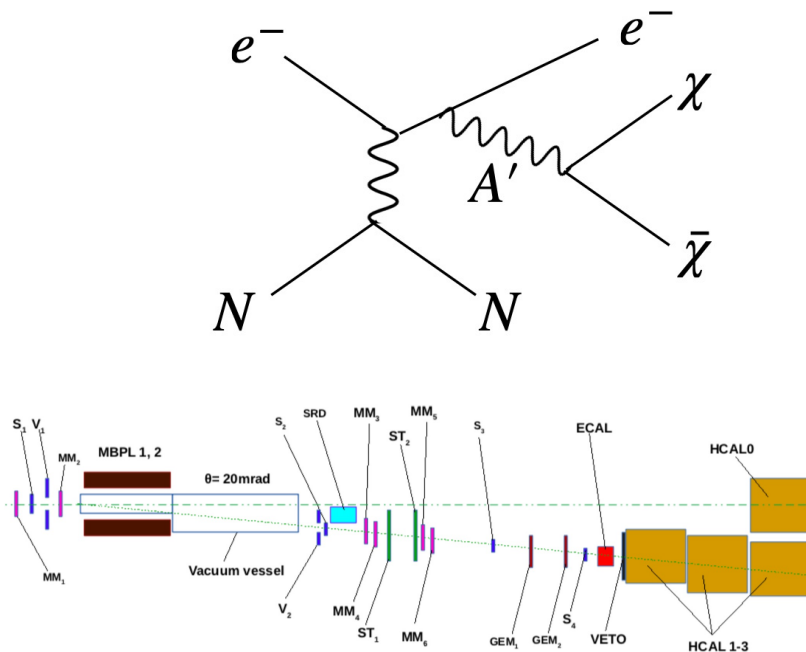

- LDMX is a proposed missing momentum experiment at LCLS-II at SLAC.

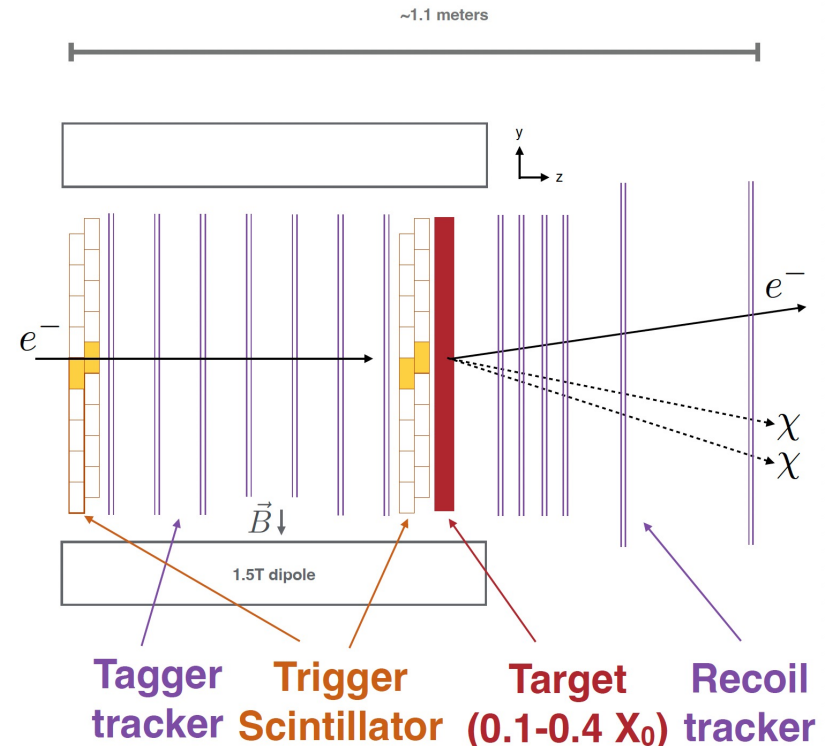

# SEARCHES AT LOW COUPLING: NA62 AND FASER

- At low coupling, the decay length can be macroscopic. Can look for  $\pi/\eta \rightarrow A'\gamma$  or  $pp \rightarrow ppA'$ ,  $A'$  travels far, then decays  $A' \rightarrow e^+e^-$ .
- NA62 is an ongoing proton beam dump experiment at the SPS at CERN.
- FASER is a current experiment in the forward region near ATLAS at the LHC at CERN.

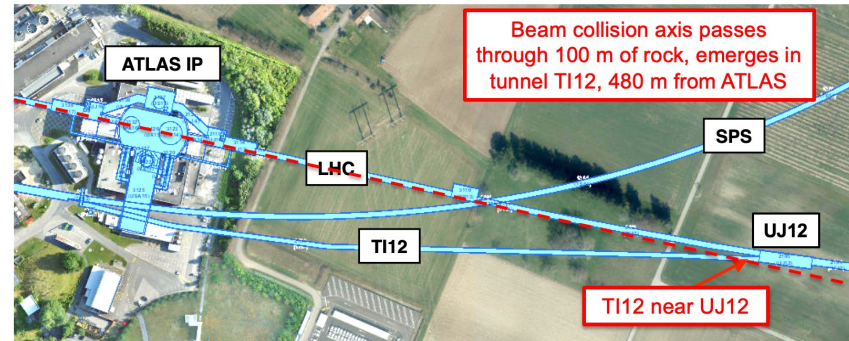
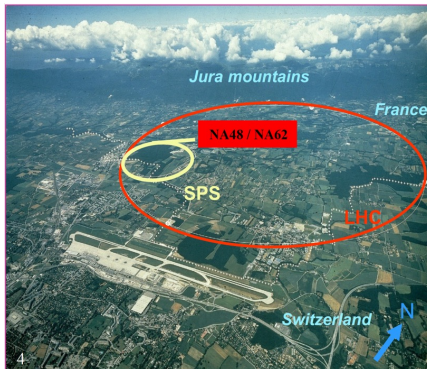

# NEW DARK PHOTON RESULTS

- FASER and NA62 presented new bounds in last 2 weeks, FASER paper out today!

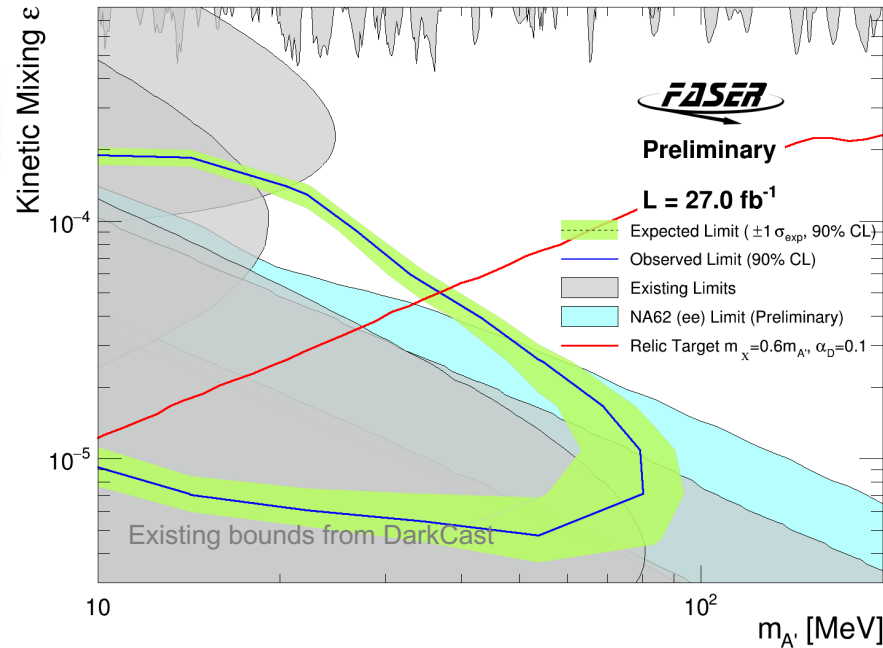

FASER Collaboration,  
[CERN-FASER-CONF-2023-001](#)

- Together they are the first incursion into the thermal relic region from low coupling since the 1990's.
- Background-free analysis bodes well for future sensitivity. Expect factor of  $\sim 10$  more luminosity in Run 3 from 2022-25.

# HIGH $P_T$ LLPS AT LHC: CODEX-B AND MATHUSLA

- Codex-b is a proposed 10 m x 10 m x 10 m experiment, underground in a unused room 25 m from LHCb at CERN.

- MATHUSLA is a proposed 100 m x 100 m x 30 m experiment located 20 m deep at a surface site ~100 m from CMS at CERN.

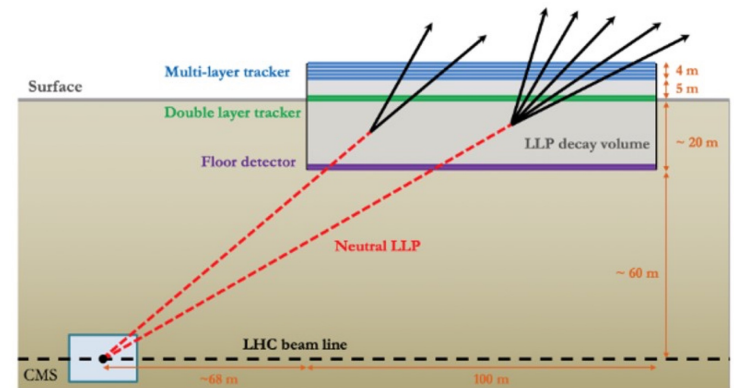
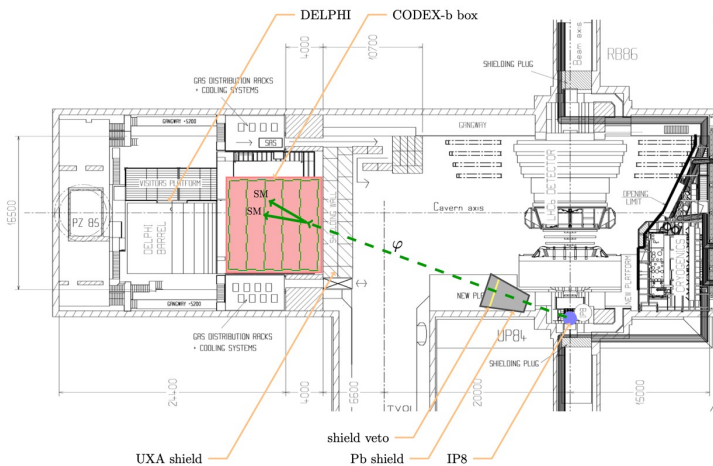
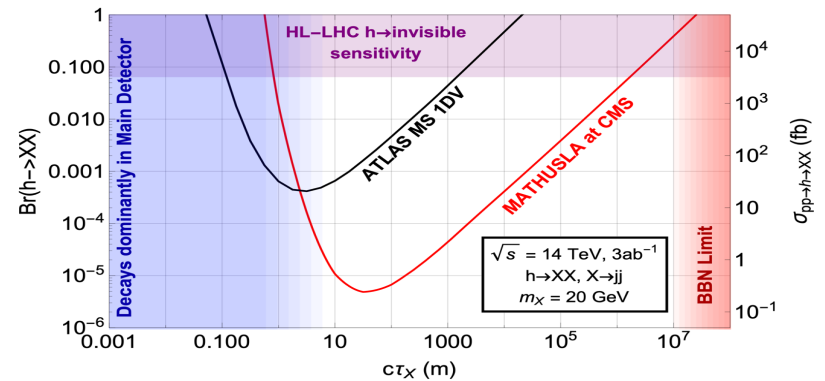
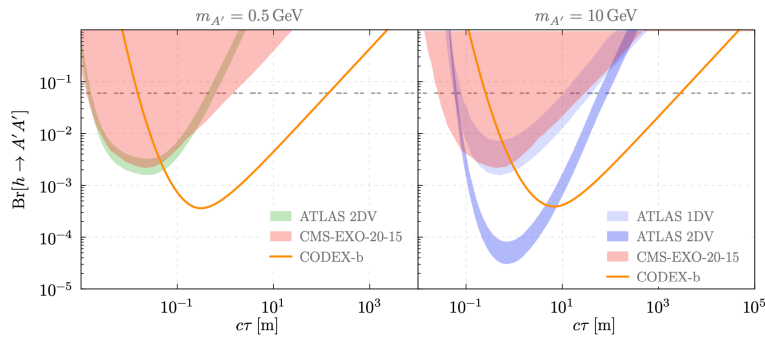



# FORWARD PHYSICS FACILITY

The rich physics program in DM and BSM, as well as in neutrinos and SM, strongly motivates creating a new, dedicated underground Forward Physics Facility at CERN for the HL-LHC era from 2028-2040s.

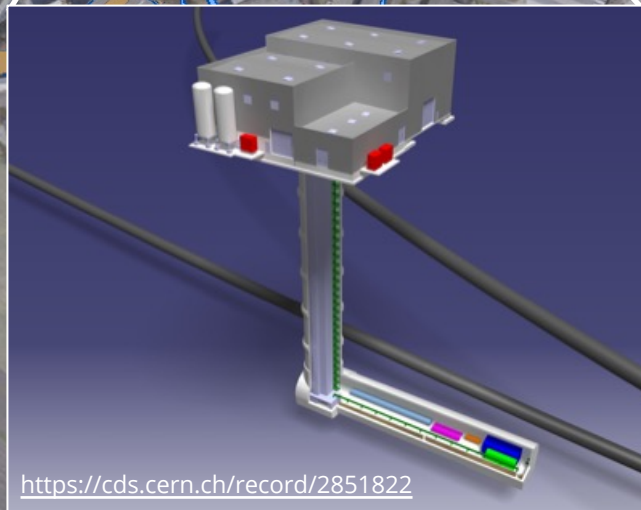
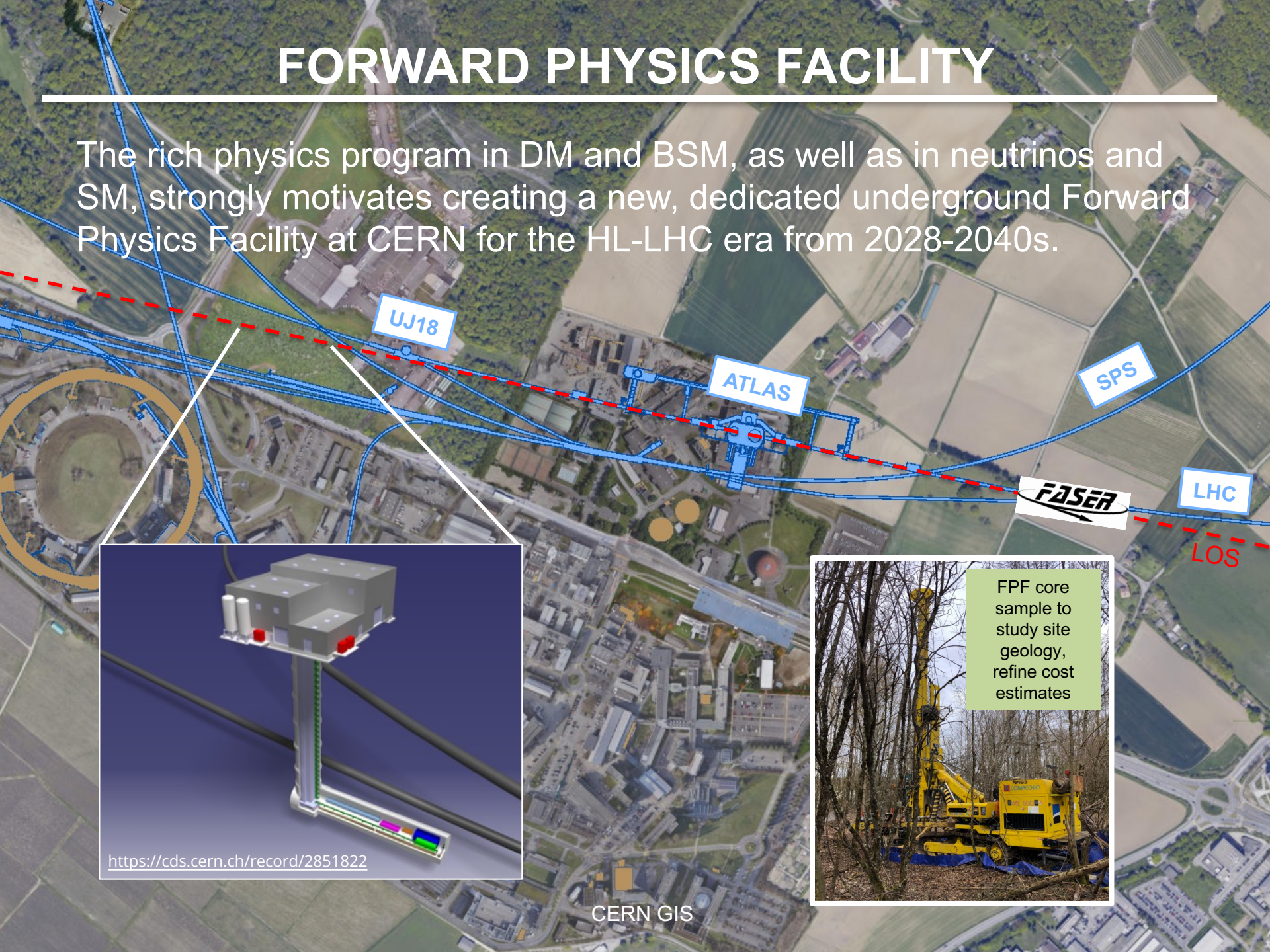

<https://cds.cern.ch/record/2851822>

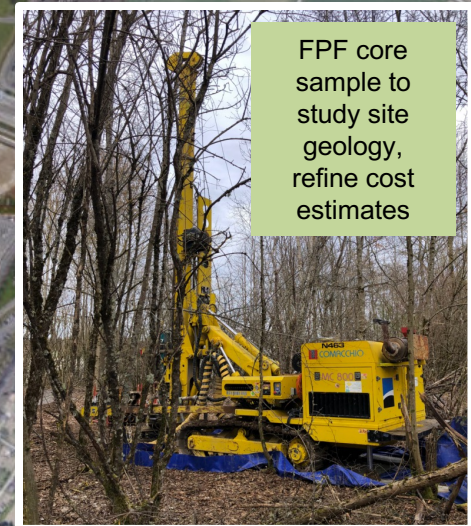

FPF core sample to study site geology, refine cost estimates

# FORWARD PHYSICS FACILITY EXPERIMENTS

- At present there are 5 experiments being designed to explore the breadth of SM and BSM topics. FPF covers  $\eta > 5.5$ , experiments on LOS cover  $\eta \gtrsim 7$ .

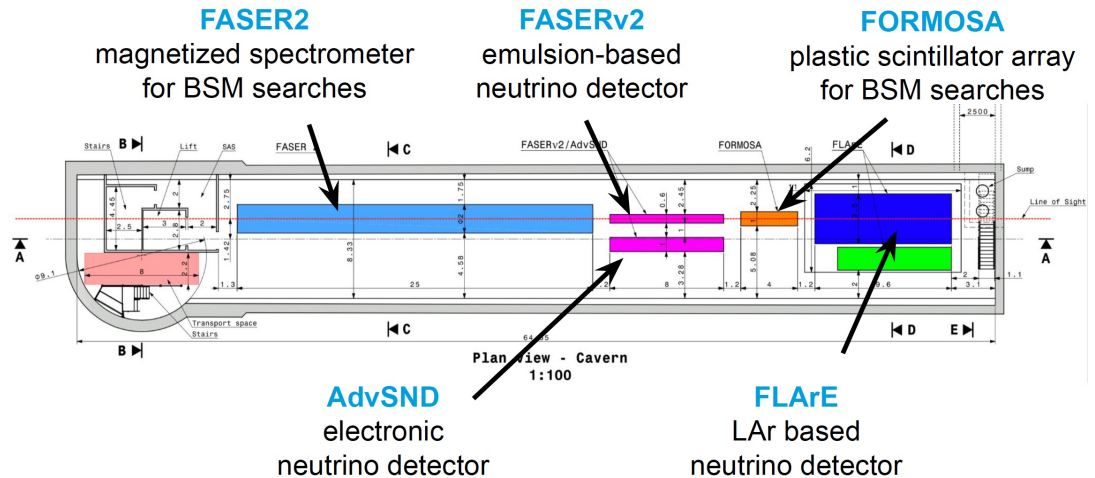

- Large far-forward fluxes are automatically provided by the LHC and can be exploited with small and inexpensive detectors. For example,
  - $\sim 10^6$  TeV-neutrino interactions per 10 tons.
  - $\sim 10^4$  dark photon decays can be observed in currently viable regions of param space.

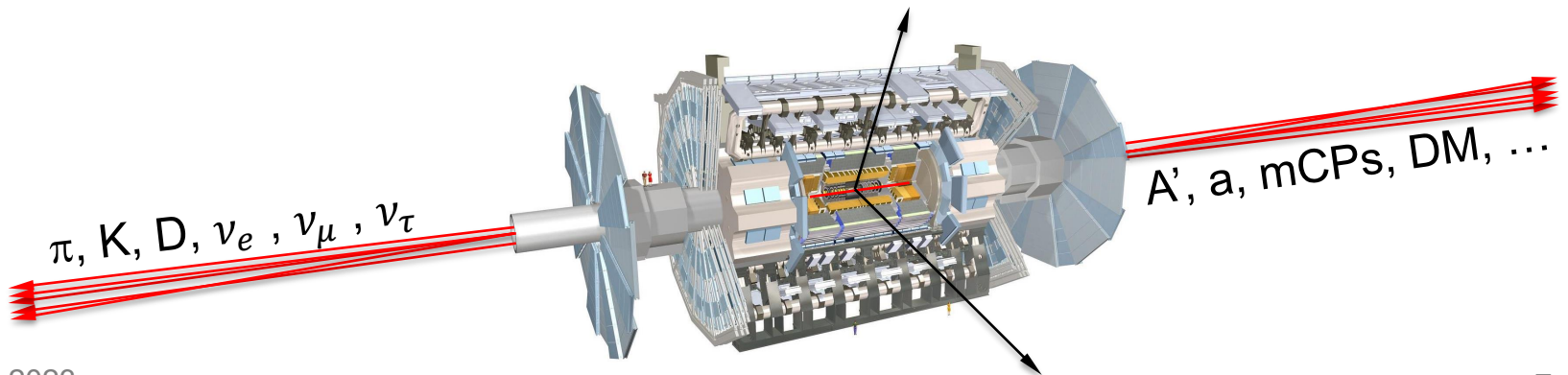

# FORWARD PHYSICS FACILITY

- The physics program in the far-forward region has been developed in a series of meetings and papers.

- FPF Meetings

- [FPF Kickoff Meeting, 9-10 Nov 2020](#)
- [FPF2 Meeting, 27-28 May 2021](#)
- [FPF3 Meeting, 25-26 Oct 2021](#)
- [FPF4 Meeting, 31 Jan-1 Feb 2022](#)
- [FPF5 Meeting, 15-16 Nov 2022](#)

- FPF Papers

- FPF “Short” Paper: 75 pages, 80 authors, Phys. Rept. 968, 1 (2022), [2109.10905](#).
- FPF White Paper: 429 pages, 392 authors+endorsers representing over 200 institutions, J. Phys. G (2022), [2203.05090](#).

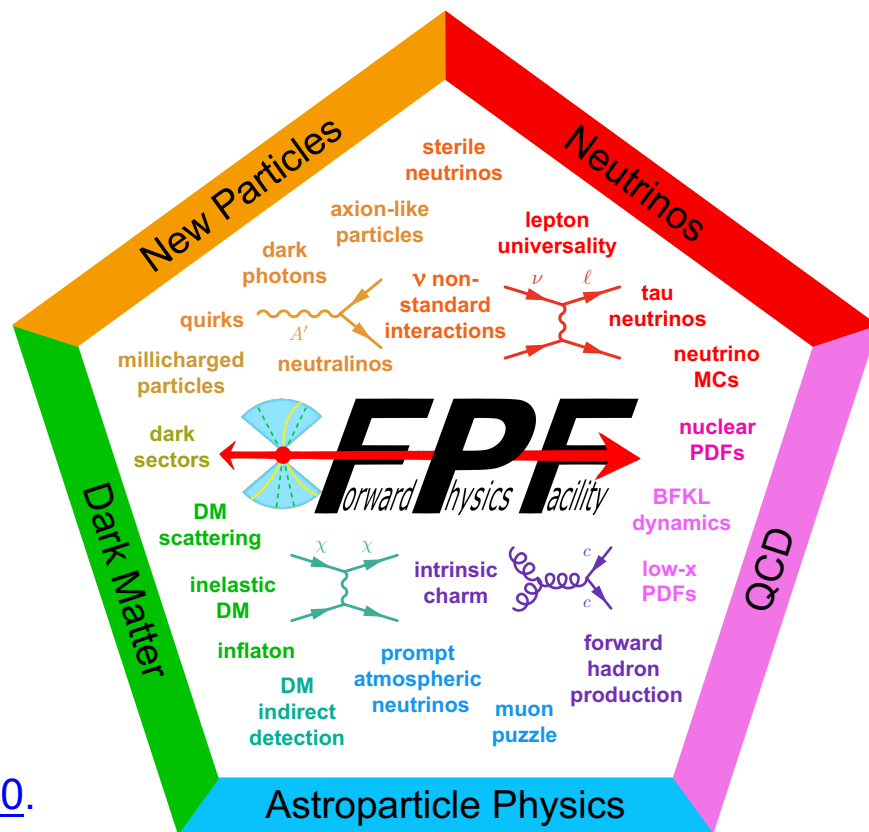

- Snowmass 2022: “Our highest immediate priority accelerator and project is the HL-LHC, ... including the construction of auxiliary experiments that extend the reach of HL-LHC in kinematic regions uncovered by the detector upgrades.”

# SUMMARY

- DM at accelerators is an extremely diverse and active topic, thermal relic targets are now being probed.
- Heavy DM,  $\sim 100$  GeV–TeV, WIMPs
  - missing  $E_T$  searches will continue at the LHC now through the 2040s.
  - Many more exotic, LLP signals also being studied with great activity.
- Light DM,  $\sim$  MeV – GeV, Dark Sectors
  - Many new accelerator and collider experiments with exciting prospects, new results are probing thermal relic target from both high and low coupling.
  - Motivate a new underground facility: the Forward Physics Facility at CERN.

