

## Scintillation detectors and phoswich detectors

*The objective of this laboratory is for the student to have hands-on experience in assembling scintillation detectors and coupling the scintillating crystal to a photomultiplier tube. This experience also includes mounting a proper electronic chain to obtain a good measurement of different sources using a scintillator. The response of other scintillators to standard gamma sources will also be evaluated and the results will be discussed.*

### Introduction

Scintillators are materials that emit light when ionizing radiation passes through them. When we talk about a scintillation detector, we refer to a scintillating material coupled to a light sensor, as a photomultiplier tube (PMT) or a photodiode, as it is shown in Fig. 1. The working principle of a PMT is the photoelectric effect, where the light coming from the scintillator removes electrons from the photocathode of the PMT (known as photoelectrons); the next step in the PMT includes a multiplication of the number of electrons through the dynodes, and so, generating an electric current. Let's remember that each dynode is an amplifier stage of the signal.

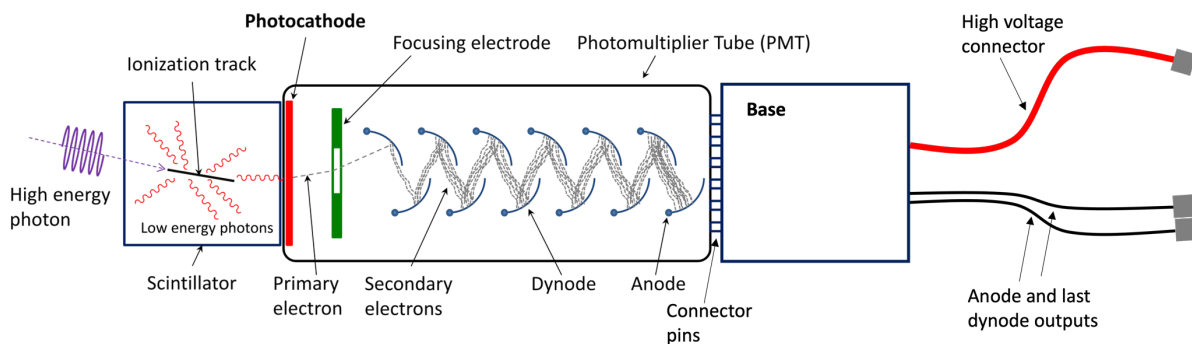

Figure 1. Scheme of a scintillator coupled to a PMT.

There are several possible sensors for scintillator materials: photomultiplier tubes (PMT), photodiodes (PD), large area photodiodes (LAPD) and silicon photomultipliers (SiPM). Here we will use PMTs.

Fig. 2 displays a phoswich detector, which is a combination of scintillators with different pulse shape characteristics that optically coupled to each other and to a common PMT (or PMTs). As each scintillating crystal emits light at different frequency and their response time is different, pulse shape analysis distinguishes the signals from the two scintillators, identifying in which scintillator the event occurred. The phoswich detector we have in our laboratory is made of  $\text{LaBr}_3(\text{Ce})$  (Brilliance380) and of  $\text{LaCl}_3(\text{Ce})$  (Brilliance350). Another important characteristic of our scintillators is that they are hygroscopic, so they must be encapsulated.

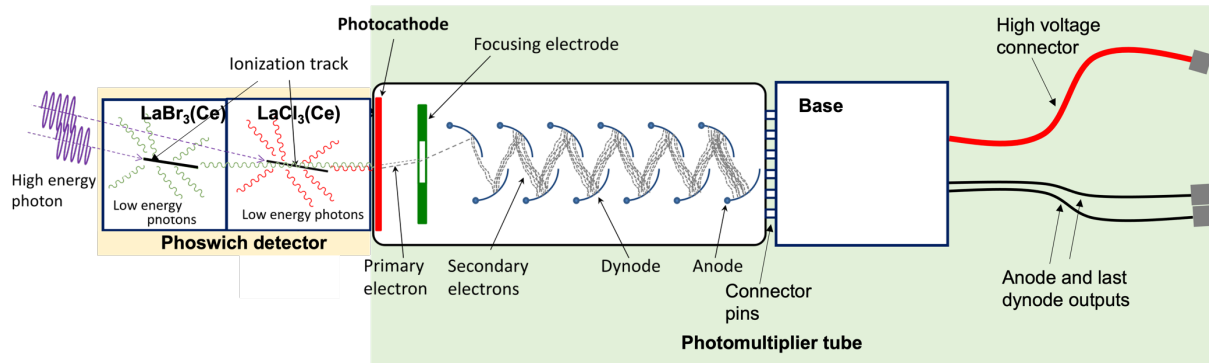

Figure 2. Scheme of the phoswich detector available in our laboratory.

In this practice, students will work with different scintillators that display different characteristics. Fig. 3 displays the relative resolution of different detectors at 662 keV. LYSO detectors have a relative resolution close to 8%, while LaBr<sub>3</sub>(Ce) and LaCl<sub>3</sub>(Ce) have better relative resolution.

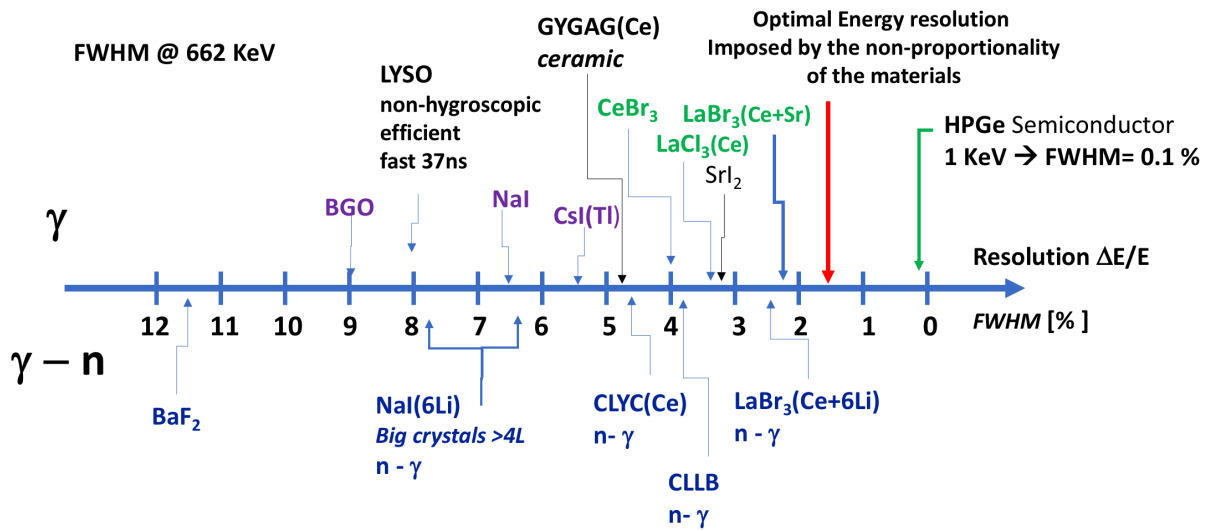

Figure 3. Relative resolution (%) of the scintillators to be used.

The decay scheme of the radiation sources that will be used during our laboratory session are shown in Fig. 4.

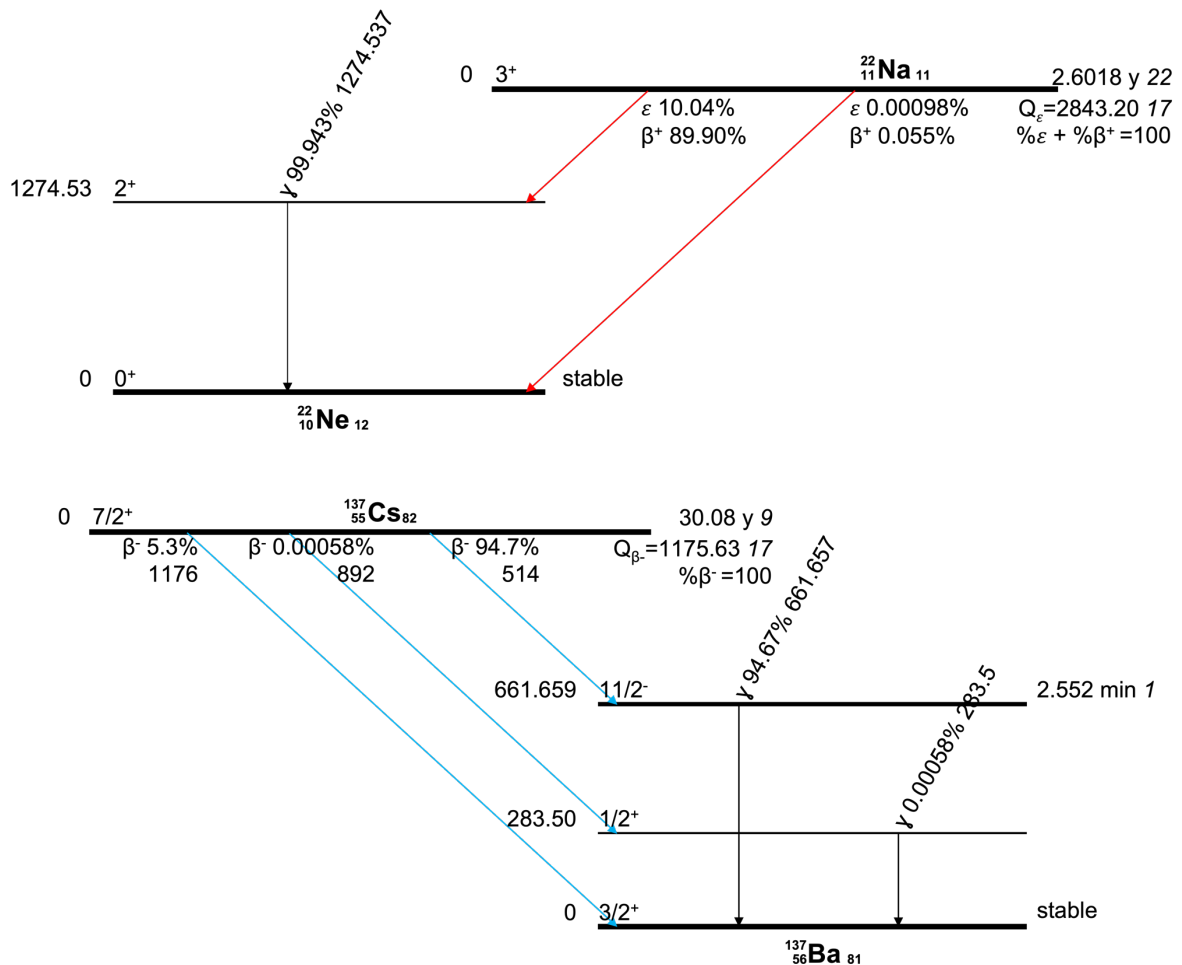

Figure 4: Decay schemes of  $^{22}\text{Na}$  and  $^{137}\text{Cs}$ .

The electronic modules that will be used (see the **Materials** section) are:

1. **Preamplifier:** Amplifies the weak signals coming from the detector, they are normally mounted as close as possible to the detector to minimize energy losses of this weak signals in the cable.
2. **Amplifier:** Amplifies the signal provided by the preamplifier and shapes it in a way convenient for further processing, this is crucial to avoid pile-up shaping at the end of the signal.
3. **Time signal discriminator:** Receives the time (fast) signal and transforms it into a logic (step) signal, that will be further utilized.
4. **Logic units:** Can perform multiple logic operations (AND, OR, ...), employed to define the conditions for the gate.
5. **Gate Generator:** Provides a logic signal of a determined width with which it is generated the acquisition trigger.
6. **Analog to Digital Converter and multichannel analyzer:** Converts the information of an analogic signal into an equivalent digital number and analyzes a stream of voltage pulses

and sorts them into a histogram, or “spectrum” of number of events, versus pulse-height, which may often relate to energy or time of arrival.

## Objectives

To introduce scintillation detectors to the students, so that they distinguish between detectors with different characteristics, and assemble the scintillators to obtain a proper measurement. For this, students have  $\text{LaBr}_3(\text{Ce})$ ,  $\text{LaCl}_3(\text{Ce})$ , and  $\text{Lu}^{1.8}\text{Y}^{.2}\text{SiO}^5:\text{Ce}$  (LYSO Prelude) detectors.

To study the detector’s signals along the electronic chain, discovering the utility of the different modules we need to measure a source spectrum. The students are provided with an oscilloscope and several standard gamma sources, so that they can analyze the response of each detector in each step of the electronic chain, and finally in the spectrum.

To analyze the response of a phoswich detector (CEPA), which is composed by several crystals of 7 cm of  $\text{LaBr}_3$  coupled to 8 cm crystals of  $\text{LaCl}_3$ , by varying the position of the radioactive source, so that the students optimize the response on each crystal.

## Materials

- |   |  |
|---|--|
| 1. Scintillating crystals                     | 8. High voltage supply                 |
| 1.a. LYSO Prelude                             | 9. Amplifier                           |
| 1.b. Phoswich detector CEPA                   | 10. Discriminator                      |
| 1.c. $\text{LaCl}_3(\text{Ce})$ Brilliance350 | 11. Gate generator                     |
| 2. Optical grease and spatula                 | 12. Multichannel analyzer (MCA)        |
| 3. Photomultiplier tube                       | 13. Oscilloscope                       |
| 4. Base of the PMT                            | 14. Standard radioactive gamma sources |
| 5. Dark insulation tape                       | 15. Gloves                             |
| 6. Scissors                                   | 16. Alcohol                            |
| 7. Preamplifier                               | 17. Tissues                            |



Figure 4. Scintillators and materials needed for this experiment.

## Laboratory procedure

1. With the help of datasheets, manuals, and bibliographic data, determine the main characteristics of the detectors and the electronic modules that will be used.
2. The first experience will be mounting the scintillators. Specifically, you are asked to couple each scintillator crystal to a PMT carefully using the optical grease. Consequently, you need to guarantee the optical insulation of the detector using the dark tape, in this way, we need to assure that the light from the environment will not pass and generate noise in our measurements.
3. With the scheme shown in Fig. 5, mount the electronic chain for a scintillation detector, in each step of the electronic chain, observe the signal shape in the oscilloscope and discuss the signal characteristics.

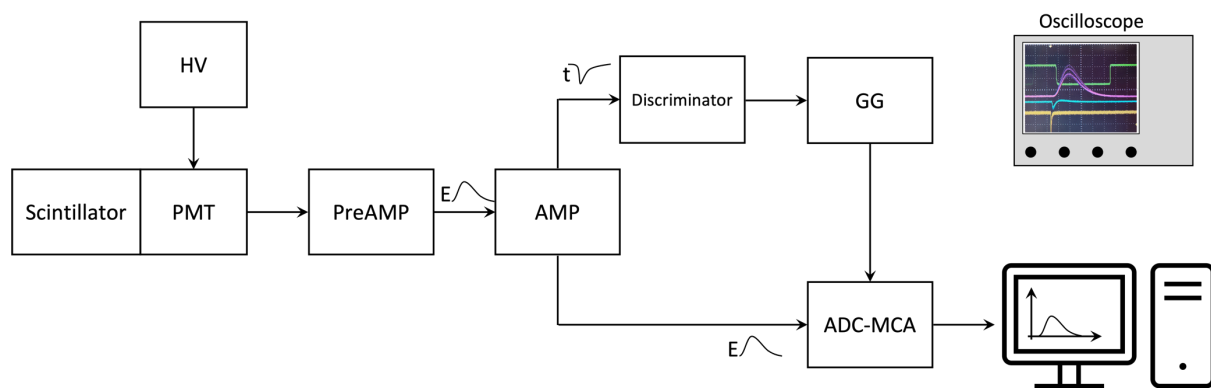

Figure 5. Electronic chain to be used for the signal analysis.

4. With the multichannel analyzer visualize the spectrum for a standard gamma source for each of the scintillating materials.
  - a.  $^{137}\text{Cs}$
  - b.  $^{22}\text{Na}$
  - c.  $^{133}\text{Ba}$

**How many peaks are observed in the spectrum?** Explain and compare the results for each of the crystals.

5. Repeat step 4 for the phoswich detector CEPA, vary the position of the source and compare the results you see.

## Laboratory report

The part of the report concerning to this practice must include the following:

- I. Explanation of the interaction mechanisms of the radiation sources with matter that were used for the experiments of “gamma spectroscopy” and “ $\gamma$ -e- coincidences”. Include the decay schemes of the sources if you think it is necessary.

- 
- II. Complete description of the detectors used in the “Gamma-ray spectroscopy with HPGe and LaBr<sub>3</sub> detectors” and “ $\gamma$ -e – coincidences with silicon and scintillation detectors”. The description must comprise a detailed comparison of the characteristics of the detectors used in each experiment, and an explanation of the choice of the detectors for each specific task.
  - III. Include a diagram of the experimental setup used in each experiment, explaining the function of each element of the electronic chain, identifying, and explaining each signal processed step by step from detector output to acquisition software input.
  - IV. After completing the data analysis of the gamma spectroscopy laboratory, comment on the correlation between the relative resolution and the energy for the HPGe detector, and your interpretation to its main associated error sources.
  - V. Regarding the  $\gamma$ -e – coincidences laboratory, explain what a two-dimensional plot is and the procedure you followed to obtain it. Discuss what you see in the mentioned plots and if that is the result you expect to observe.

## Reports

---

All reports must be sent to: [master.nuclear@iem.cfmac.csic.es](mailto:master.nuclear@iem.cfmac.csic.es)  
For questions you can write to me: [amanda.nerio@csic.es](mailto:amanda.nerio@csic.es)

## References

---

1. F. Knoll: “Radiation detection and measurement”.
2. <http://www.hamamatsu.com>
3. <http://www.detectors.saint-gobain.com>