



# ExpertRoot. A GEANT4 and FairRoot based Sim and Reco framework for experiments at ACCULINNA2 and SuperFRS facilities

Mikhail Kozlov<sup>1,5</sup>; Sergey Belogurov<sup>1,2</sup>; Vratislav Chudoba<sup>1,3</sup>; Andrey Fomichev<sup>1</sup>; Elvira Gazeeva<sup>1</sup>; Alexander Gorshkov<sup>1</sup>; Sergey Krupko<sup>1</sup>; Bakytbek Mauey<sup>1</sup>; Ivan Muzalevskiy<sup>1,3</sup>; Egor Ovcharenko<sup>1,4</sup>; Anh Mai Quyn<sup>1</sup>; Ilyas Saityshev<sup>1</sup>; Vitaliy Schetinin<sup>1,5</sup>

1 - JINR, Dubna; 2 - NRNU MEPhI, Moscow; 3- Silesian University, Opava; 4- Uni. Giessen; 5 - BMSTU, Moscow

# Outlook

---

- Introduction
- Architecture
- Event based workflow
- Example of an experiment
- Simulation “step by step”
- Real data handling
- Event reconstruction
- Summary and plans
- G4 feedback

# Introduction

---

*ExpertRoot* is a FairRoot based framework for simulation of detector`s response, event reconstruction and real data analysis **in low energy nuclear physics with radioactive beams**

*ExpertRoot* is used for the EXPERT<sup>1</sup> project at SuperFRS@FAIR and for the experiments at ACCULINNA-2 fragment-separator in JINR

<sup>1</sup> EXPERT - EXotic Particle Emission and Radioactivity by Tracking

[er.jinr.ru](http://er.jinr.ru)

# Introduction: EXPERT

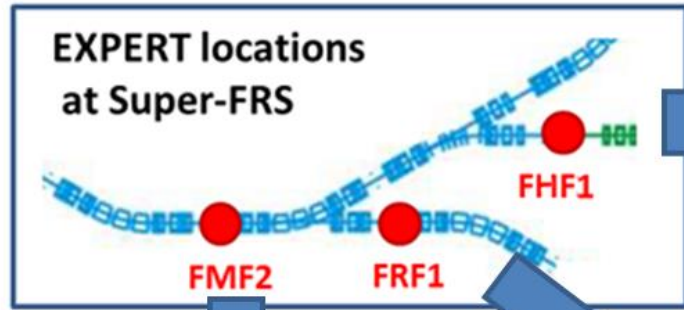

Gadast

OTPC

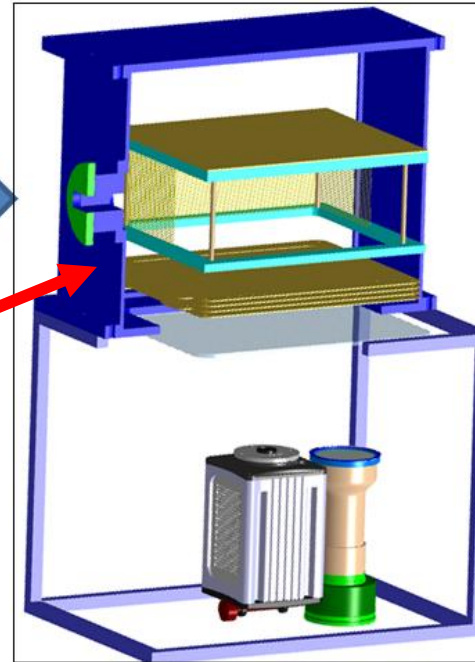

NeuRad

$\mu$ Si

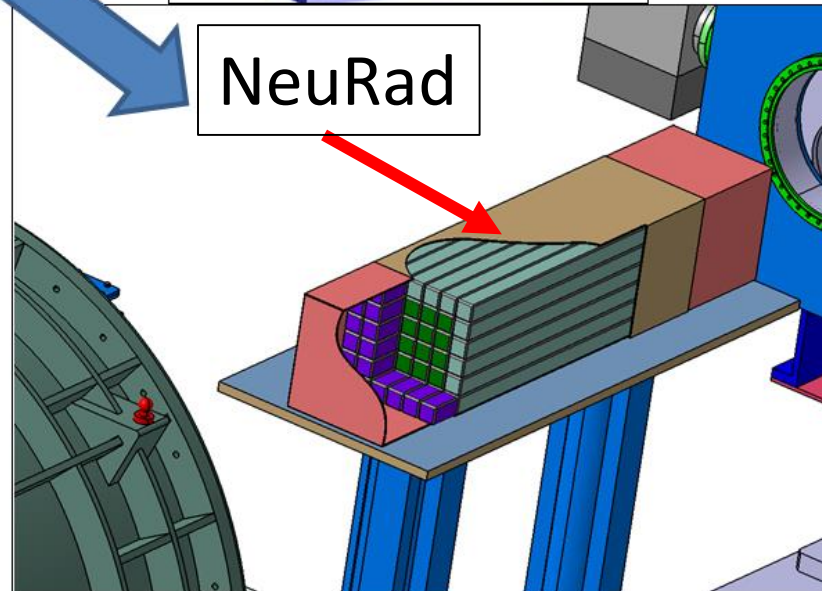

- **Gadast** – GAMMA Detectors Around Secondary Target
- **NeuRad** – NEUtron RADioactivity
- **OTPC** – Optical TPC
- **$\mu$ Si** – microstrip Si-detector



# Introduction: ACCULINNA-2, part of the current setup

QTelescope

E-station

Veto-station

$\Delta E$ -station

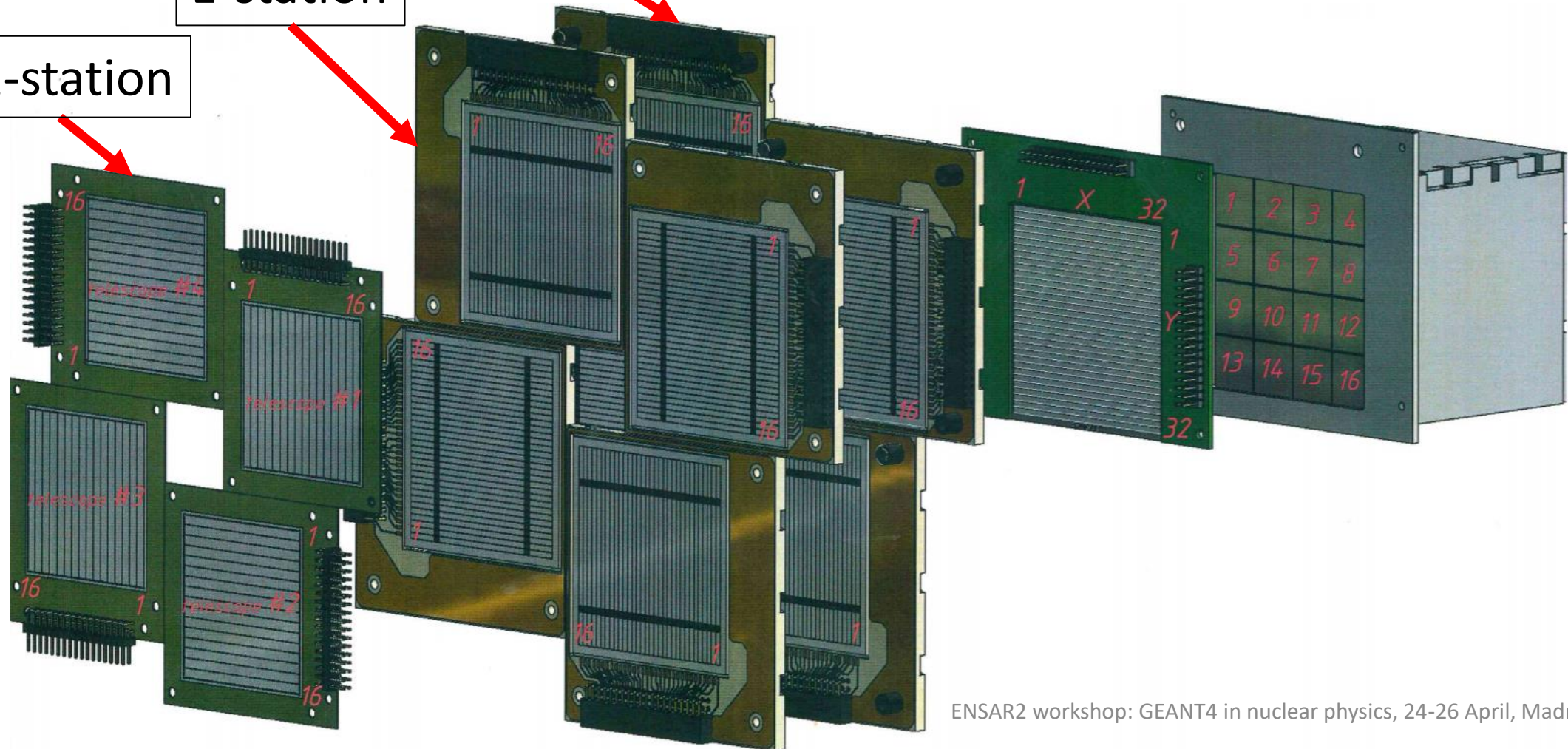

# Architecture

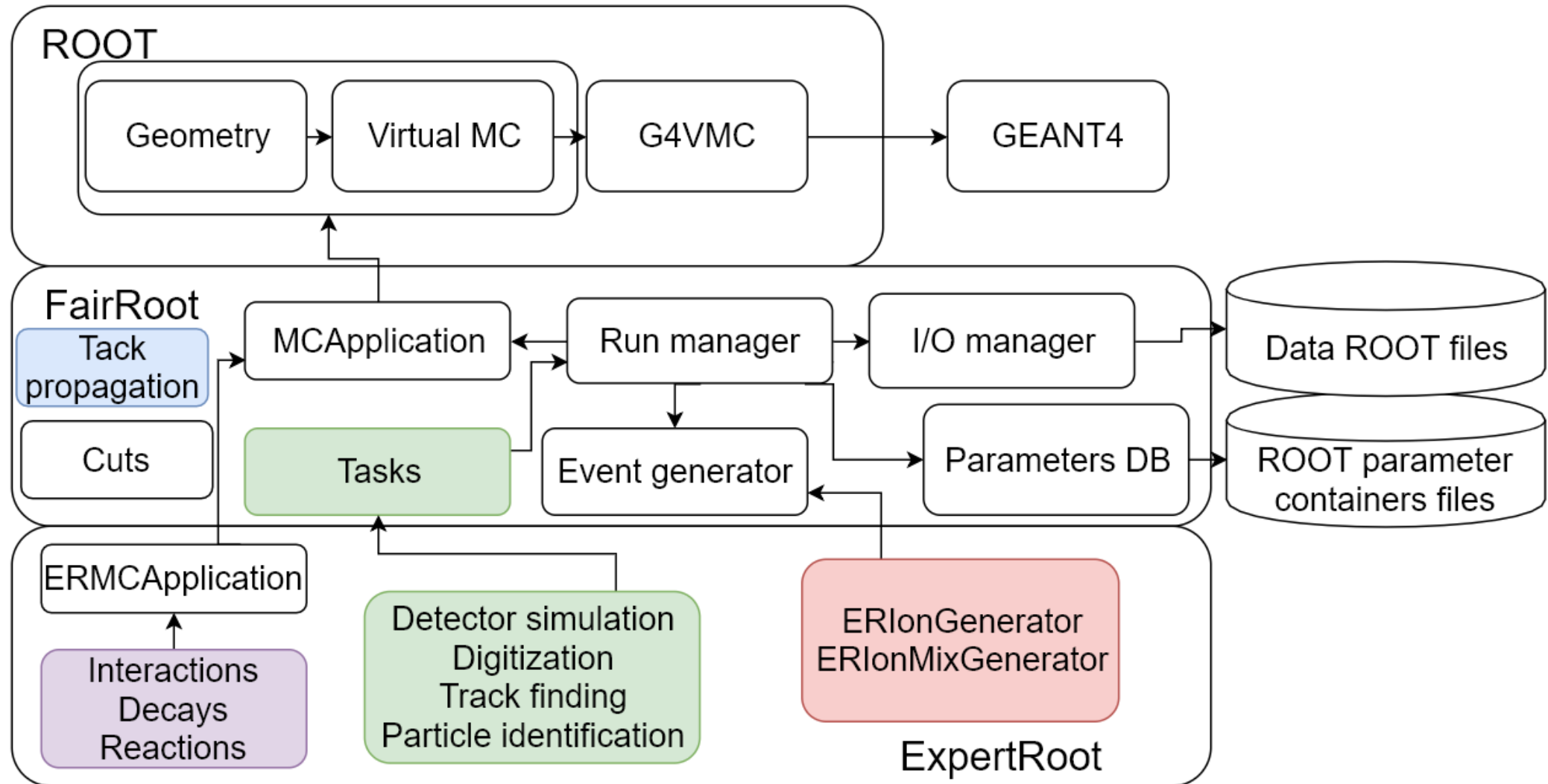

# Event-based workflow

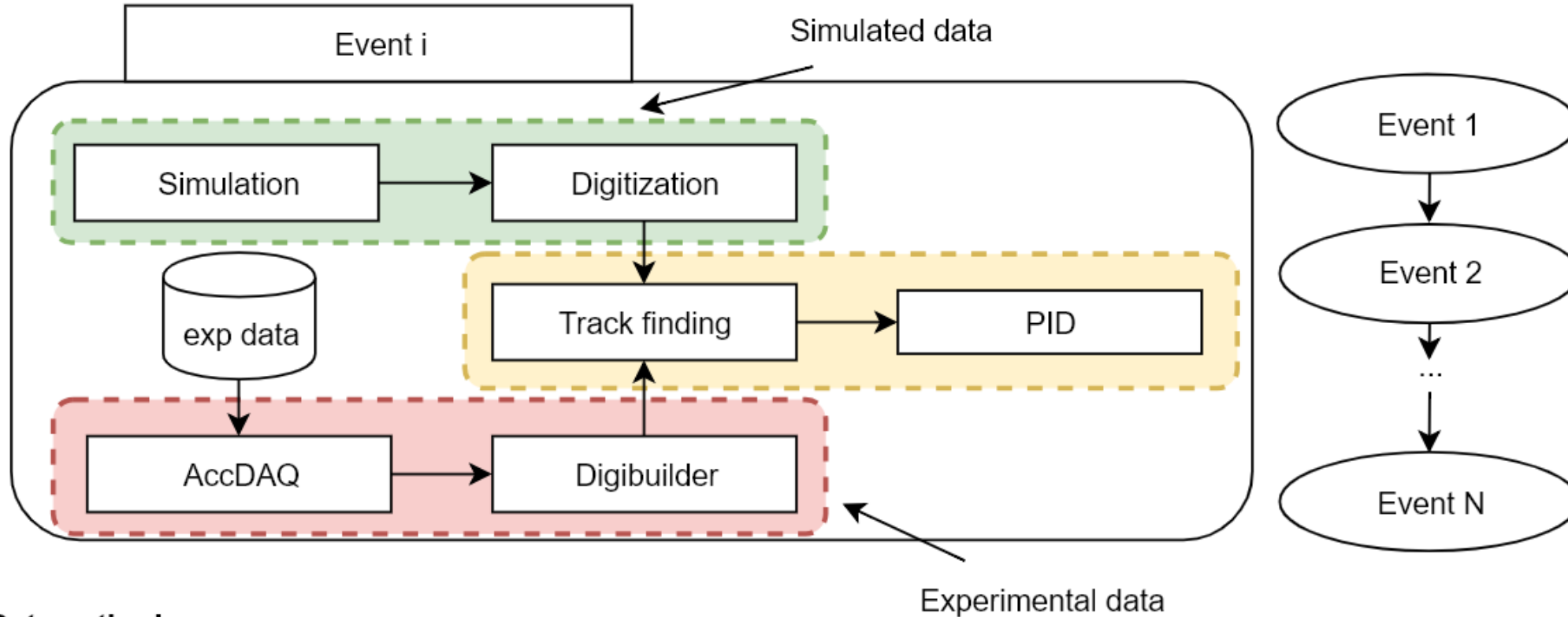

## Data gathering

- Monte-Carlo simulation of an experiment and digitization of a simulated data.
- or
- Real experiment DAQ

} common format of the output data, so the same reconstruction algorithms are used!

## Data analysis

- Reconstruction of the events

# Example of an experiment

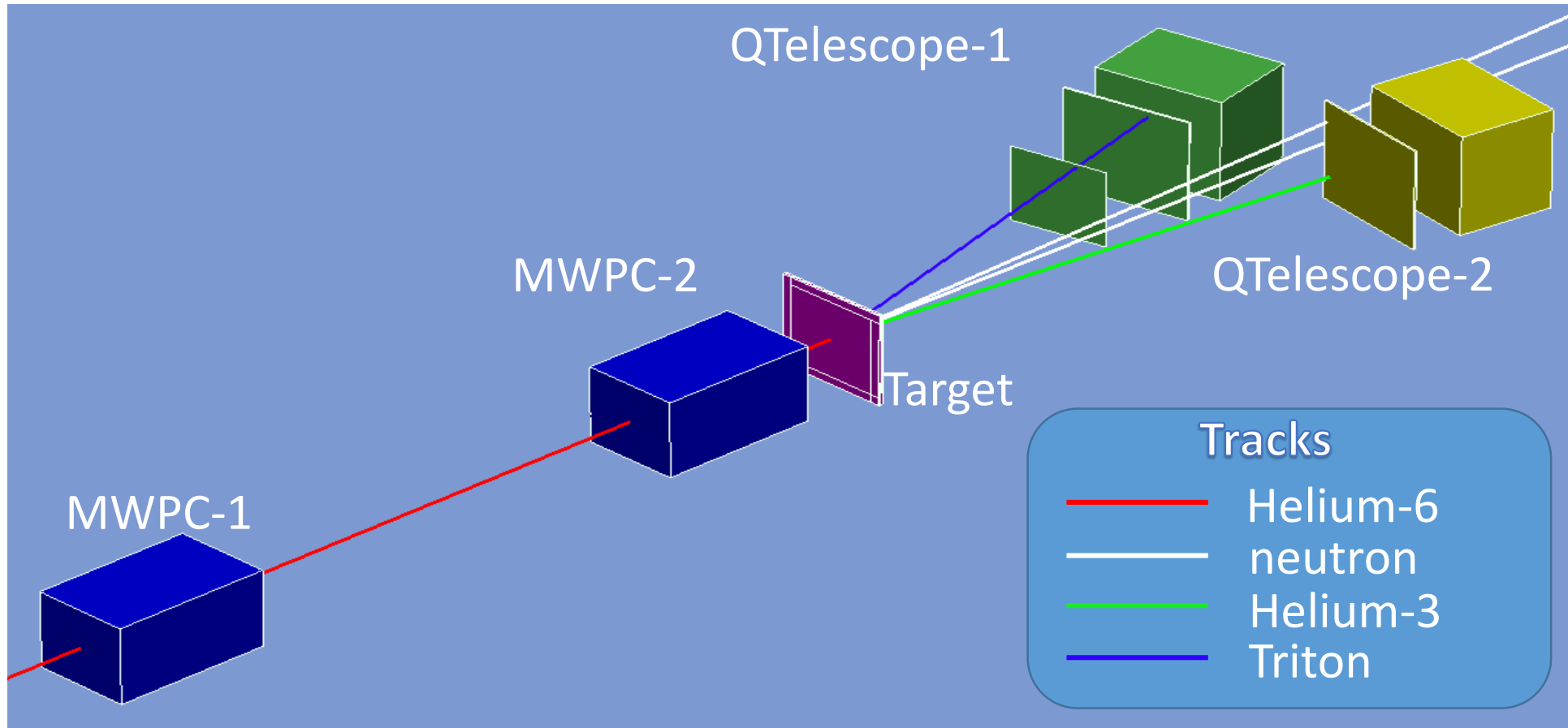

- On each step in sensitive volume energy losses are summed up for every particle via ROOT interface to Geant methods
- Information about generated primary tracks and daughter secondary particles are stored in MCTrack class object



# Ion mixture generator

ToF-dE

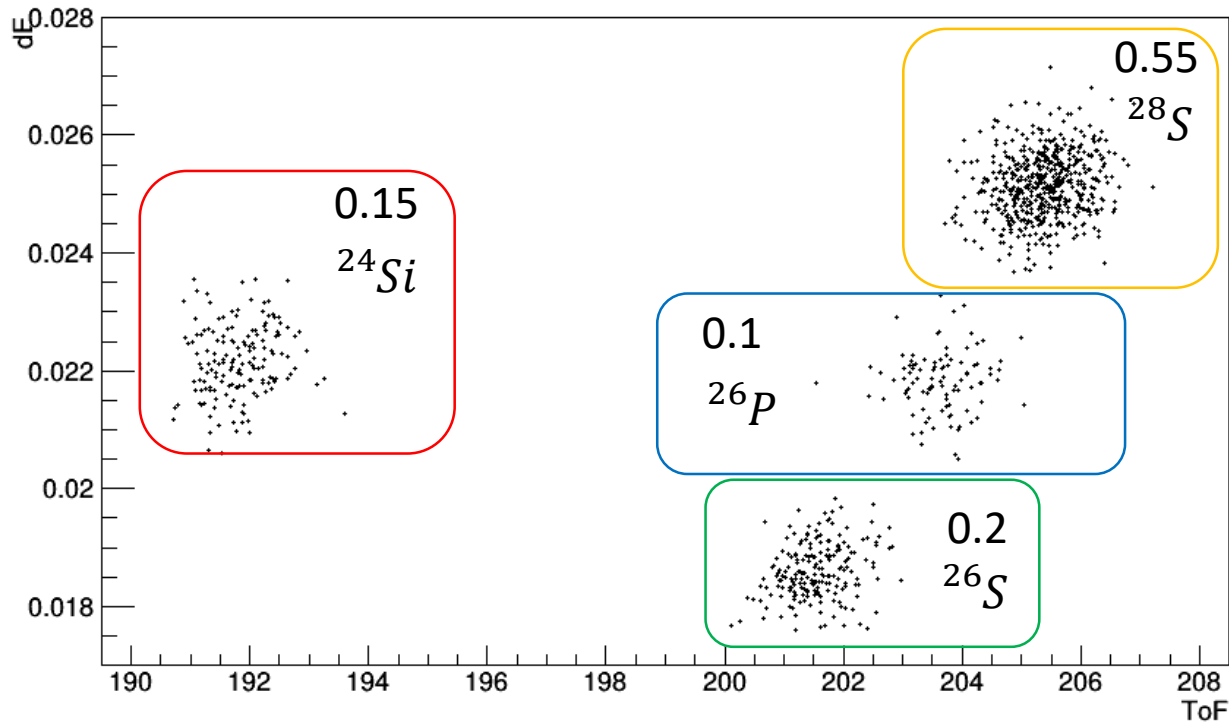

ToF

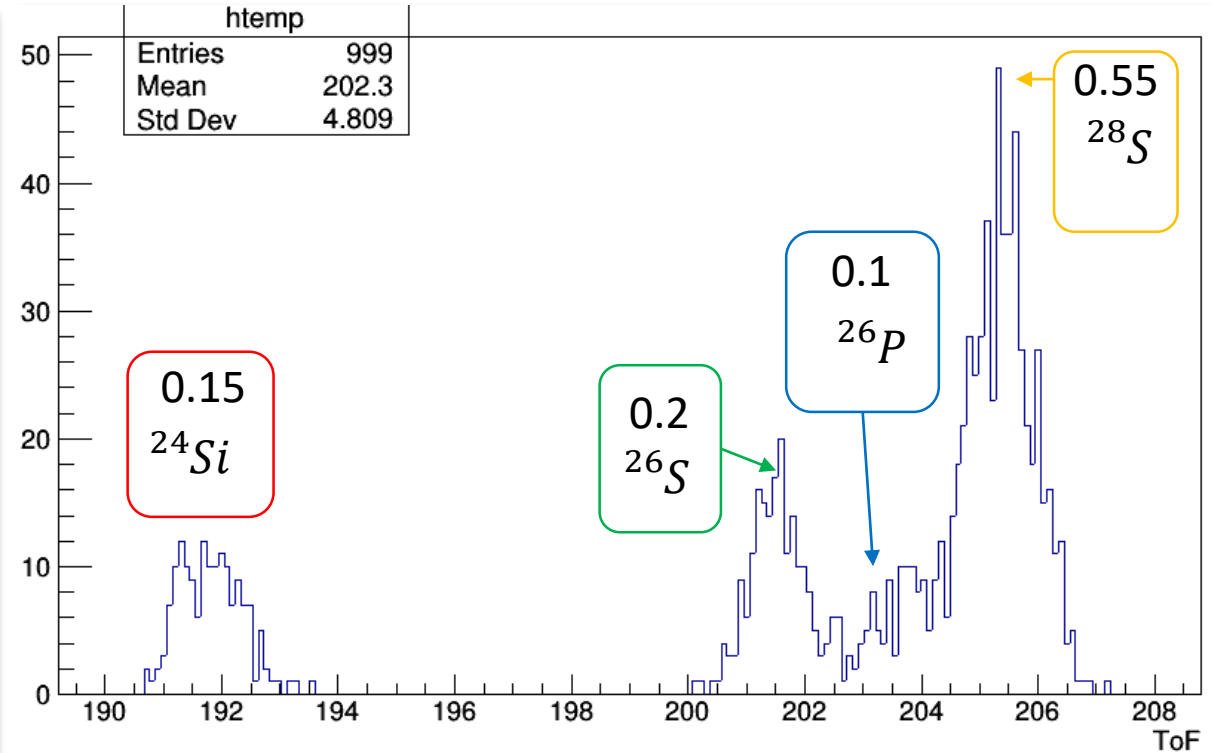

- An arbitrary count of mixed particles;
- Probability of ion occurring is normalized related to main ion in mix;
- The same magnetic rigidity  $B\rho = \frac{pc}{q}$ ;

Denomination:

Ion's occurring probability	P
Ion	$A_X$

# User defined interactions architecture

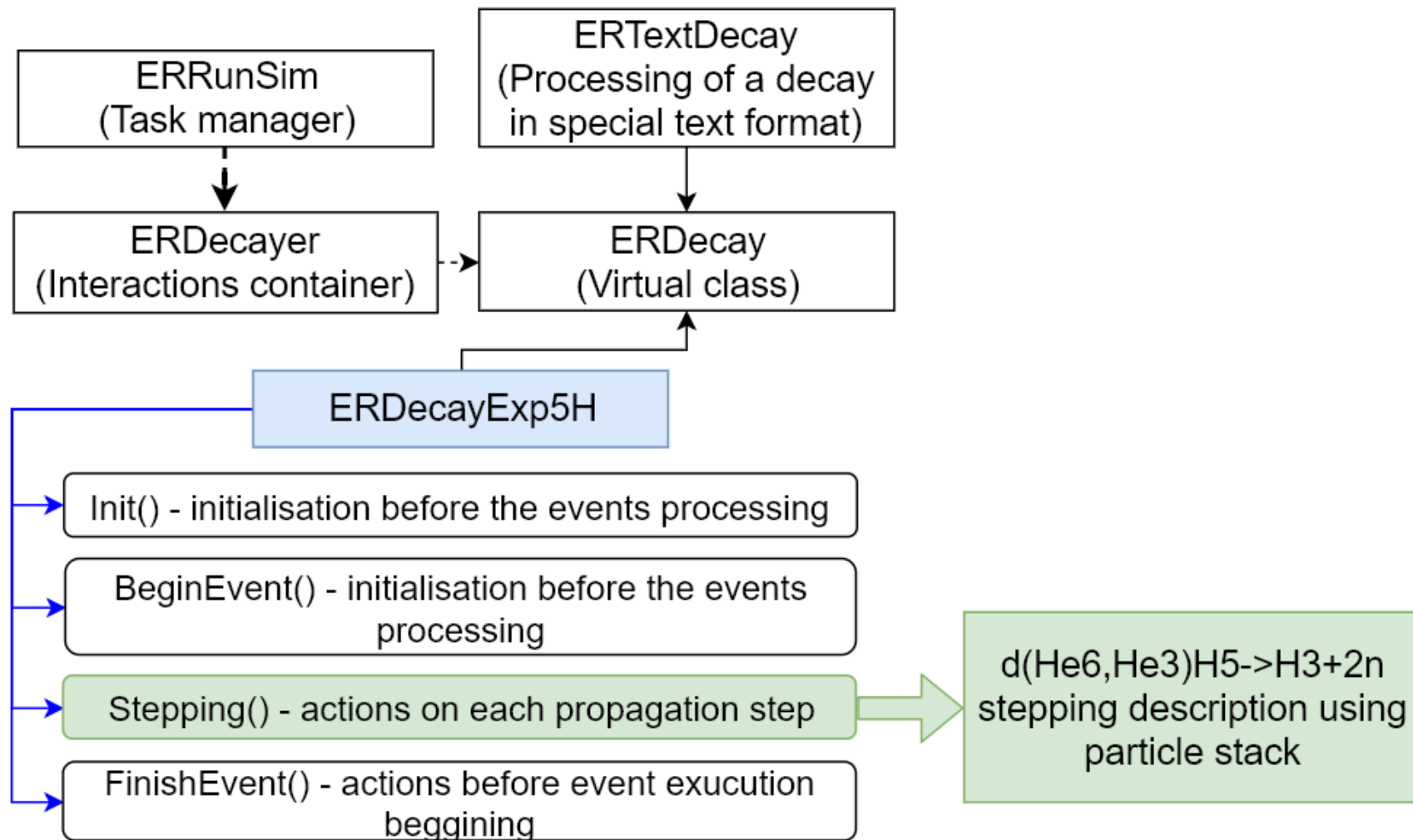

# An interaction on the target

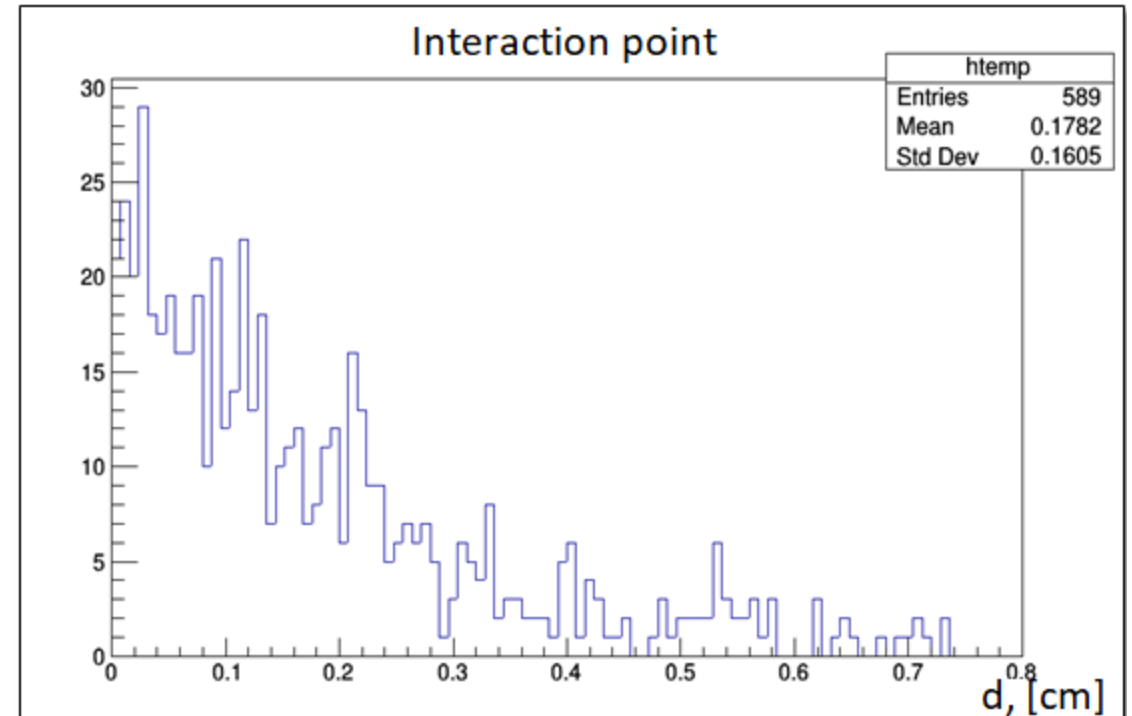
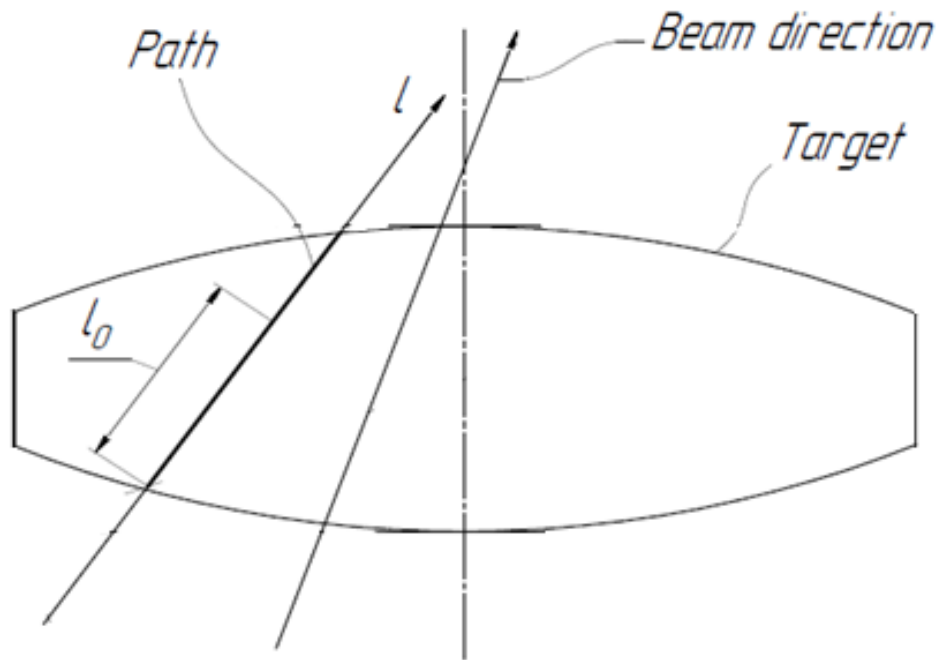

- Calculation of the material thickness along the trajectory length  $l$ ;
- Normalization of the probability relatively to maximal material thickness on the particle path;
- Exponential distribution on the interval  $[0; l]$ .

# Work with process stack example

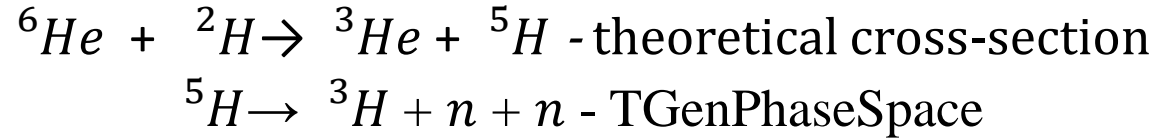

- Erase primary  ${}^6\text{He}$  track: `gMC->StopTrack()`
- ${}^5\text{H}$  is not pushed into track stack
- Add  ${}^3\text{H}$  track to the stack of processes:  
`gMC->GetStack()->PushTrack(1, He6TrackNb, fH3->PdgCode(),  
lvH3->Px(),lvH3->Py(),lvH3->Pz(),  
lvH3->E(), curPos.X(), curPos.Y(), curPos.Z(),  
gMC->TrackTime(), 0., 0., 0.,  
kPDecay, h3TrackNb, fH3->Mass(), 0);`

where is `He6TrackNb` -  ${}^3\text{He}$  track number, `fH3` – triton ion object, `lvH3` – triton four-vector, `curPos` – current particle position.

Target input  
boundary

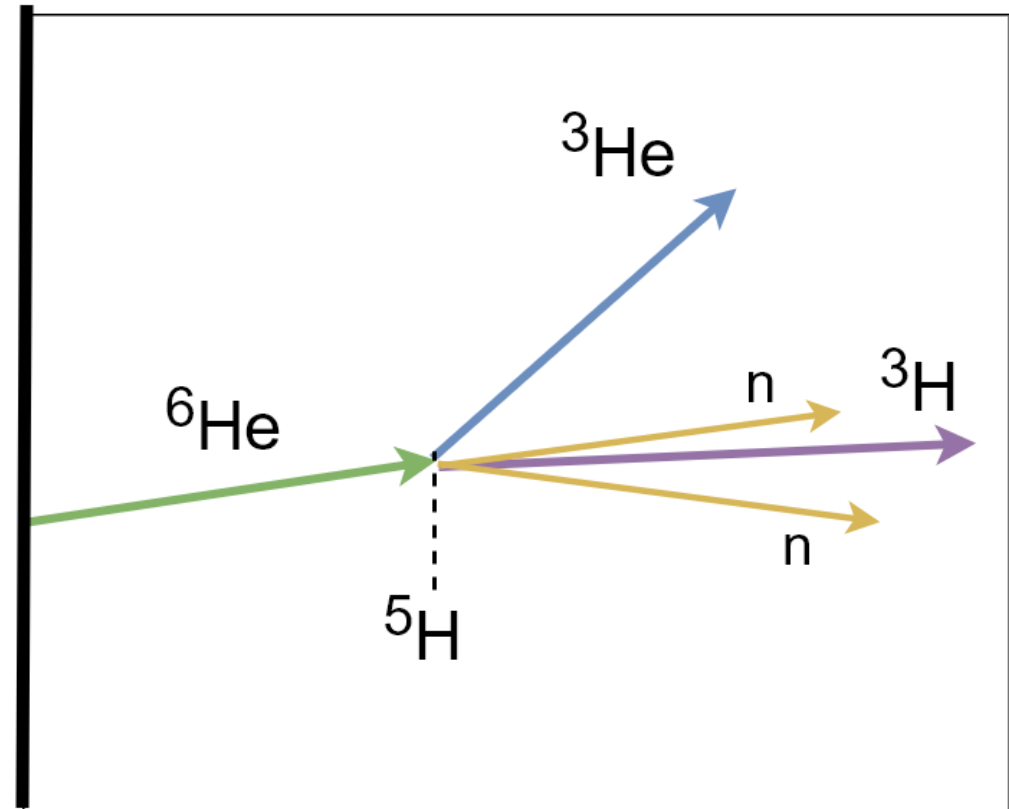

# Detector simulation

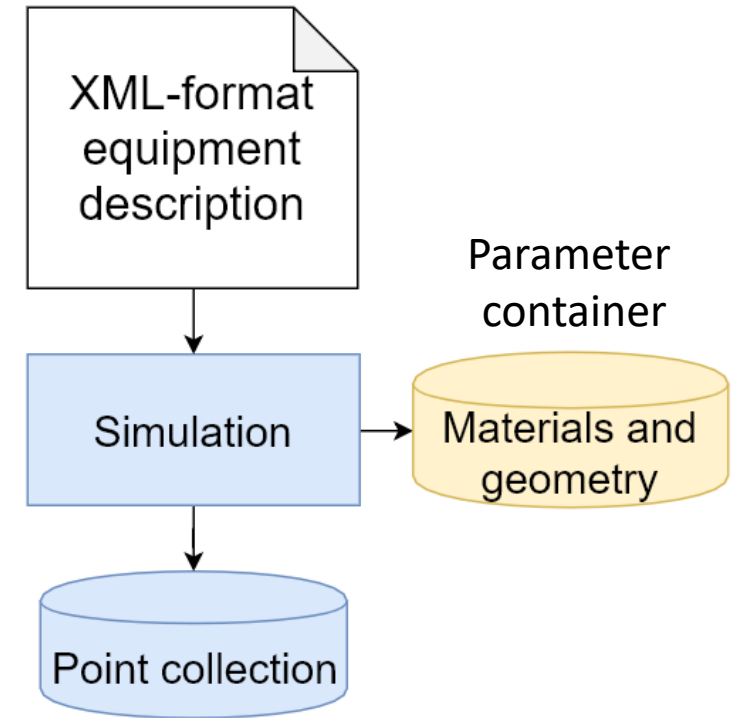
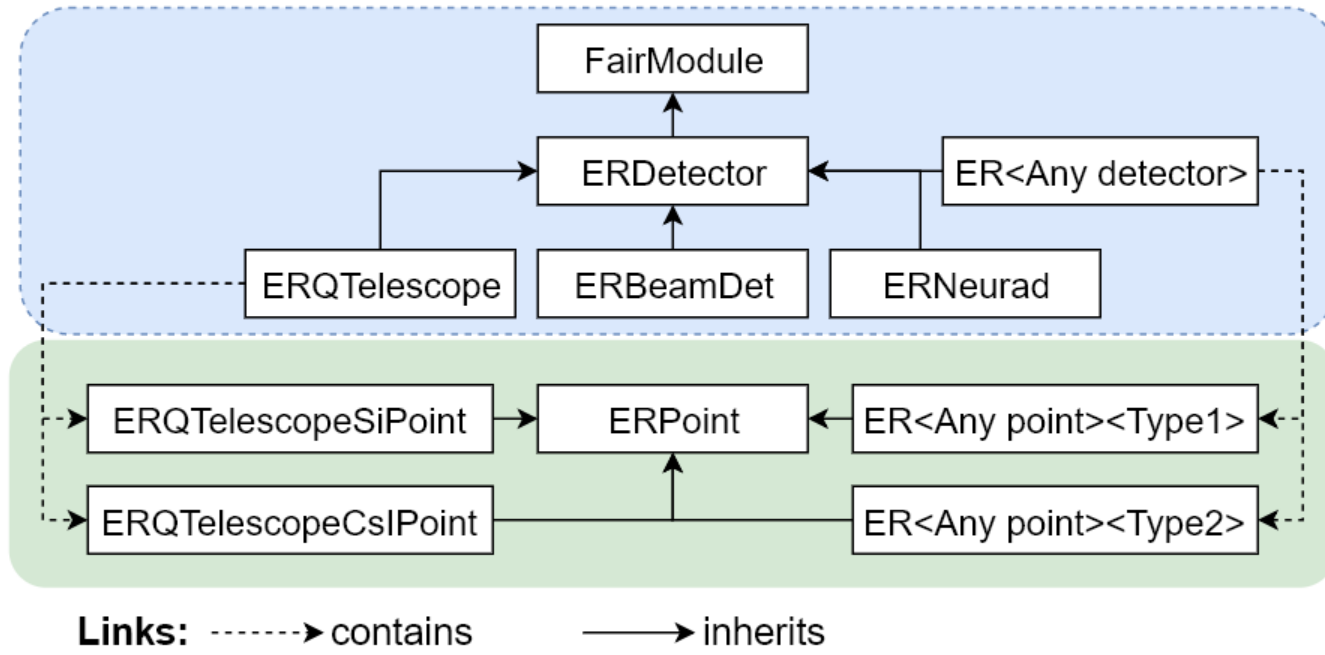

Point object is created for each particle in every sensitive volume:

- “In” and “out” coordinates
- “In” and “out” momentum
- PDG,
- “In” time
- Other detector specific information.



# Detector geometry parameterization

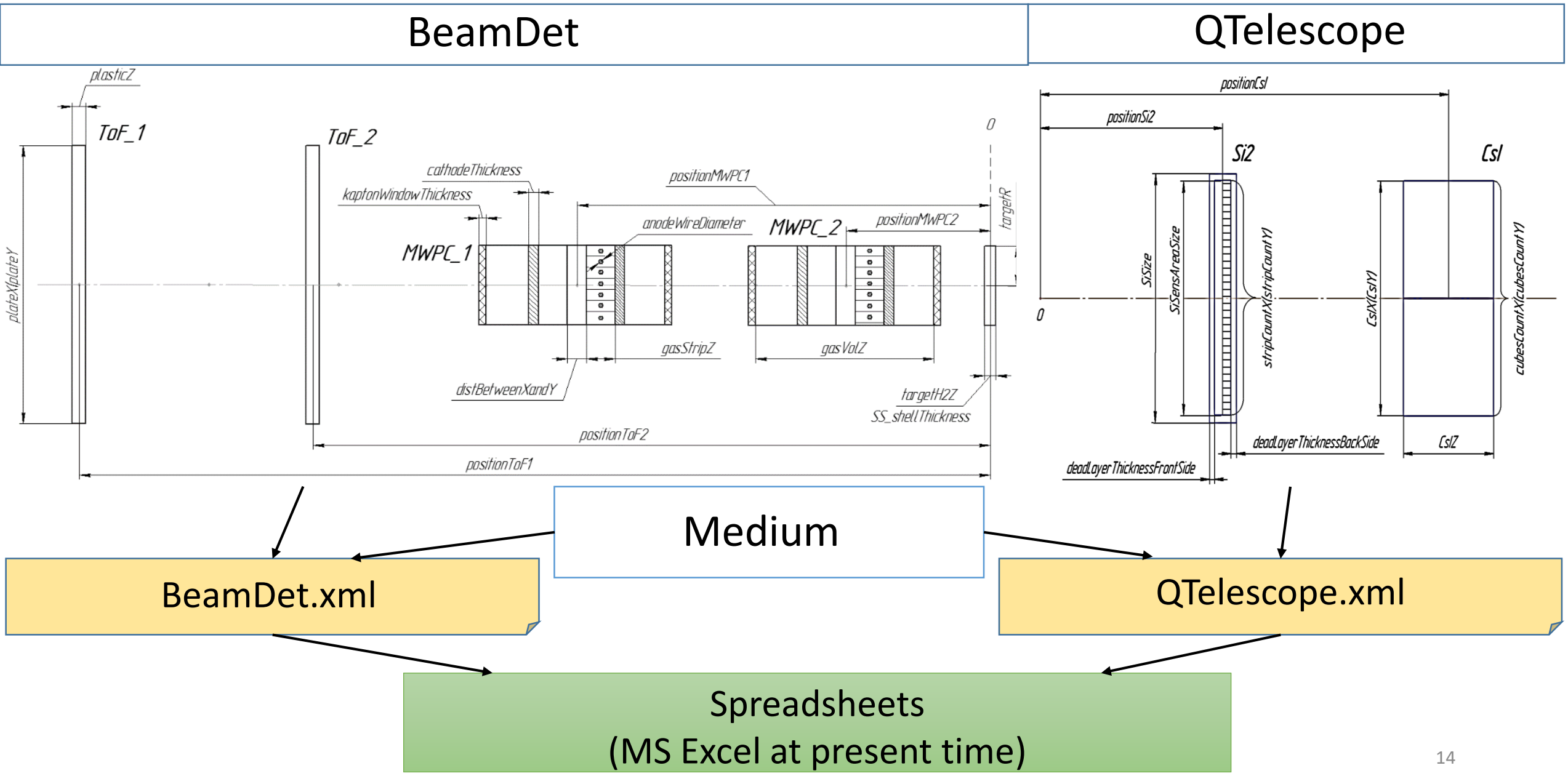

# Digitization

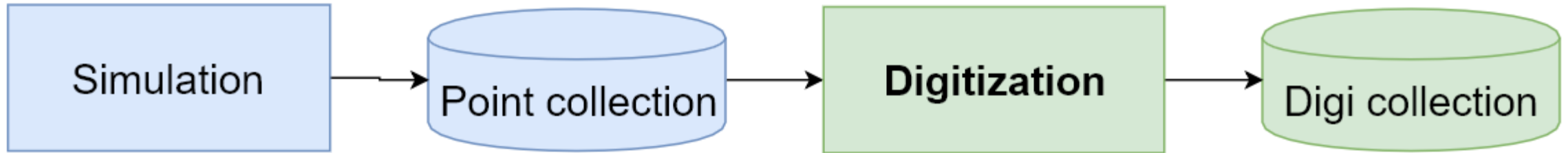

**Digitization** – task consists of summing up energy deposited by all the particles in the sensitive volume, application of energy and time spread corresponding to the resolution of the detector, taking into account inefficiency of various nature (e.g. dead time) and discretization.

**Digi** – object contains the characteristics of the detector response.

Digi object is created for each particle in every sensitive volumes:

- R/O channel number,
- Energy response, recorded to the channel,
- Timestamp
- Other detector specific information.

# Digitization

Example: NeuRad - neutron detector with scintillating fibers along the path of neutron

- Birks quenching
- Position sensitivity obtained by limiting lengths of a point to 2 [cm],
- Exponential lighting emission kinetics
- light attenuation
- quantum efficiency
- diode system modeling:
  - using special distribution of photoelectron amplitude
  - using user-defined function of photoelectron signal shape
  - delay and jitter
  - signal creation as a sum of signals from single electrons

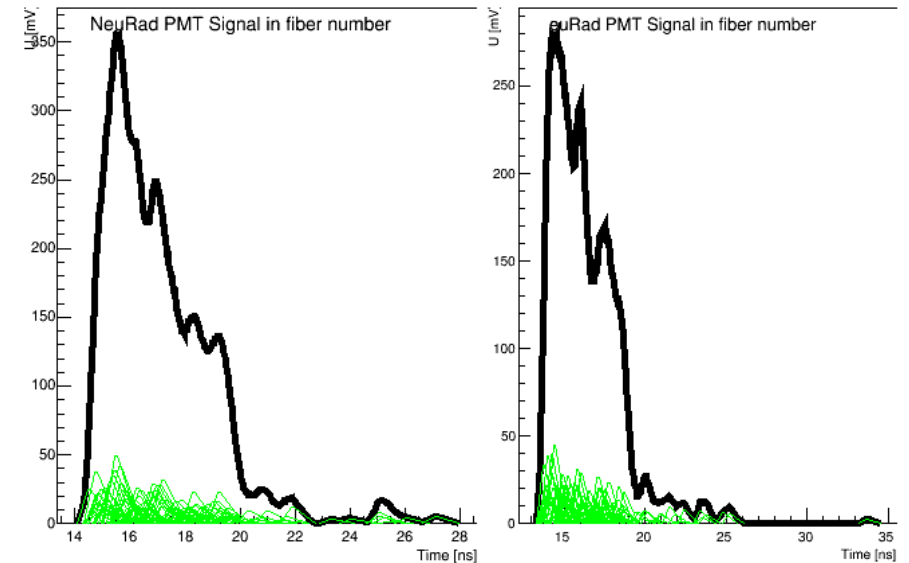
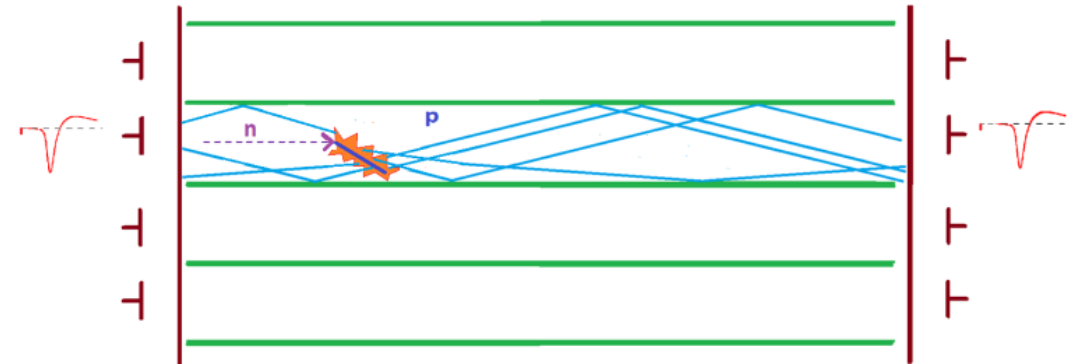

# Real data handling

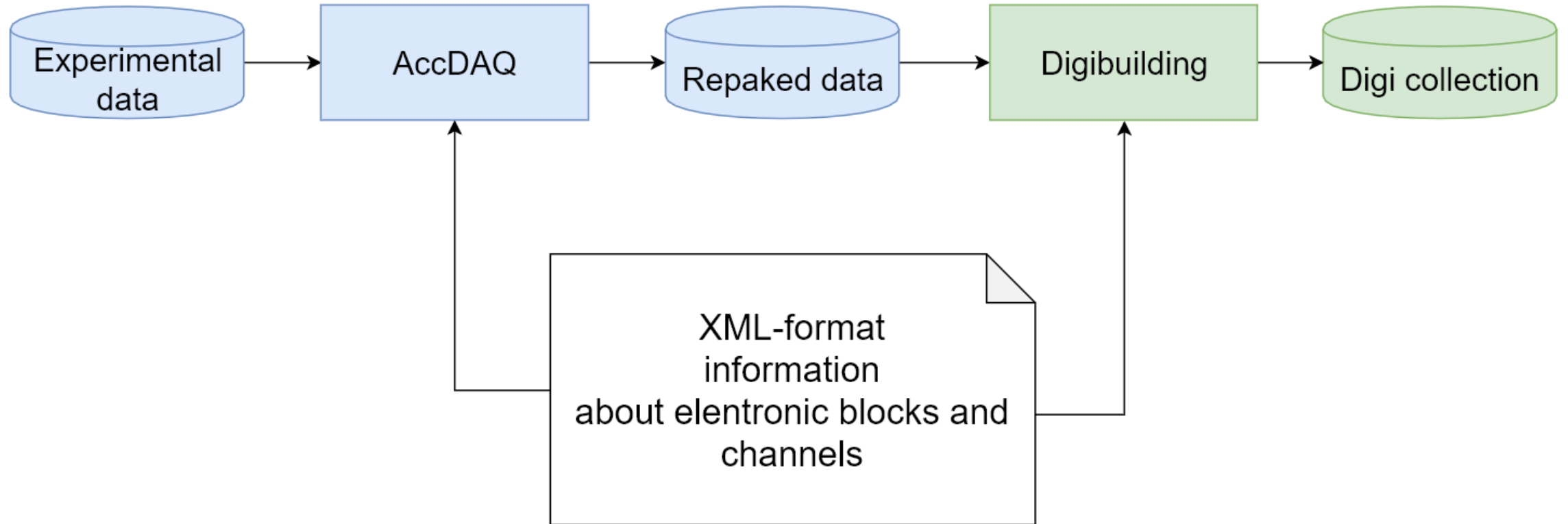

# Event reconstruction

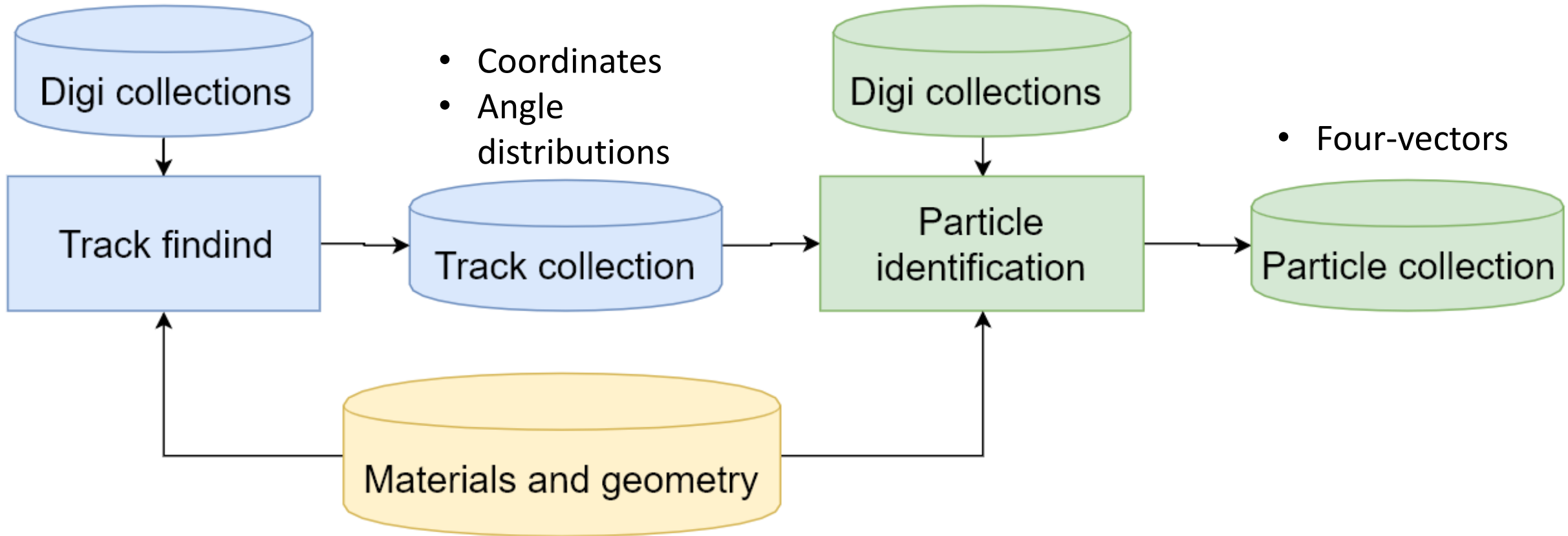



# G4EMCalculator in reconstruction

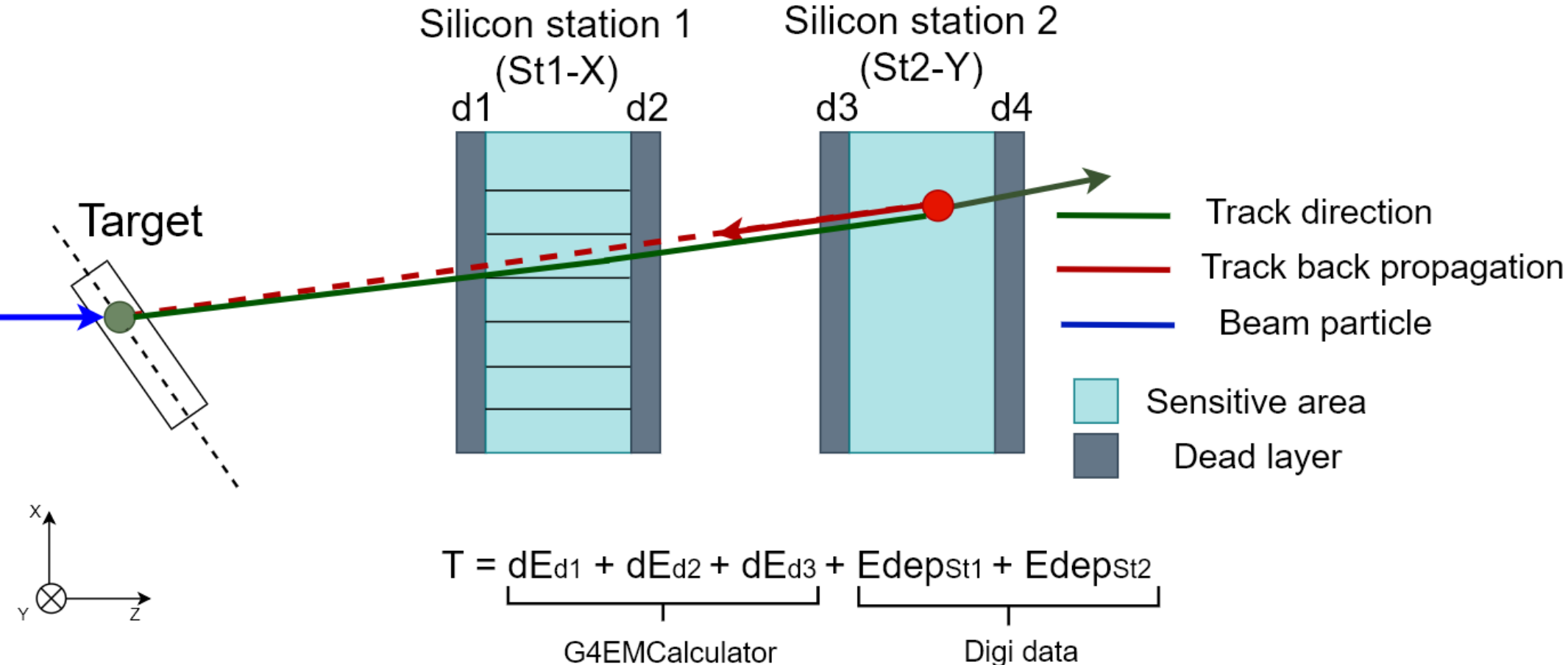

# Summary and plans

---

- *ExpertRoot* framework is developed for simulation and reconstruction of the experiments with low energy exotic beams.
- A full lifecycle functionality is implemented for the  $^5\text{H}$  and  $^7\text{H}$  experiments and can be easily extended to other examples.
- The framework helps to combine efforts of physicists, detector experts and IT specialists

## Plans:

- Implement more usecases and make the framework more userfriendly
- Develop a cloud service using Jupyter Notebook interface to Root
- Extend interface to theoretical generators. In particular interpolate multiparticle output between the provided energies observing the momentum and energy conservation and phase space factor and introduce realistic background

# G4 feedback

---

## Limitation:

Calling `G4EmCalculator->GetDeDx()` requires full initialization of Geant4 in VMC:

- TG4RunConfiguration initialization
- TGeant4 initialization
- Fake processing of first event for initialization of other environment

## Desire:

- Possibility to use the `G4EmCalculator` without initializing the entire Geant4 simulation would be extremely convenient.