

1. The Mu2e Experiment: Search for $\mu + N \rightarrow e + N$

The **Mu2e Experiment** will search for the neutrino-less coherent conversion of a muon into an electron in the field of an aluminum nucleus. Such **Charged Lepton Flavor Violating process** allows to probe energy scales up to thousands TeV, far above the reach of direct searches at the energy frontier colliders. If no conversion events are observed in three years of data taking, Mu2e will set the limit on the ratio between the muon conversion rate and the capture rate $R_{\mu e} < 3 \times 10^{-17}$ (@ 90% C.L.).

Production Solenoid (PS)

An 8 GeV proton beam hits a tungsten target
A graded magnetic field reflects muons to the TS

Cosmic Ray Veto (CRV)

4 layers of plastic scintillator bars
Covers the entire DS and half of the TS

Straw Tracker (TRK)

20000 low mass straw drift tubes
Momentum resolution 180 keV/c

Electromagnetic Calorimeter (ECAL)

Two annular disks
Energy, Time and Position measurements

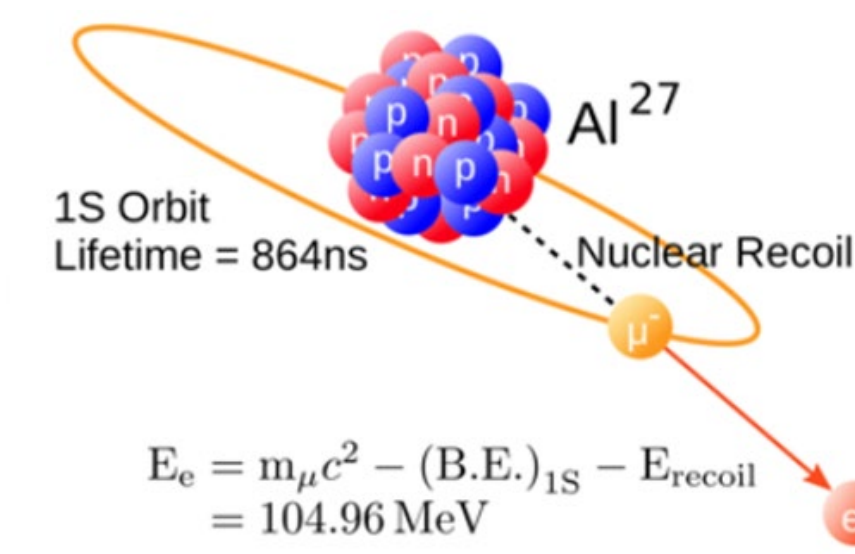

Experimental Technique

Stop muons in Aluminium
Muons quickly get to 1S orbit
Lifetime of muonic atom is 864 ns
Search for the 105 MeV conversion electron

Transport Solenoid (TS)

Selects low momentum negative particles
Antiproton absorber at the beginning and in the mid-section

Detector Solenoid (DS)

Capture muons on the Aluminium stopping target
1 T field and 10^{-4} Torr vacuum in the detector zone

Schematic view of the Mu2e beamline

2. Electromagnetic Calorimeter

The EM calorimeter is composed of a pair of twin annular matrices (disks) of 674 undoped CsI crystals placed downstream of the straw-tracker at a relative distance that maximizes the conversion electrons detection efficiency.

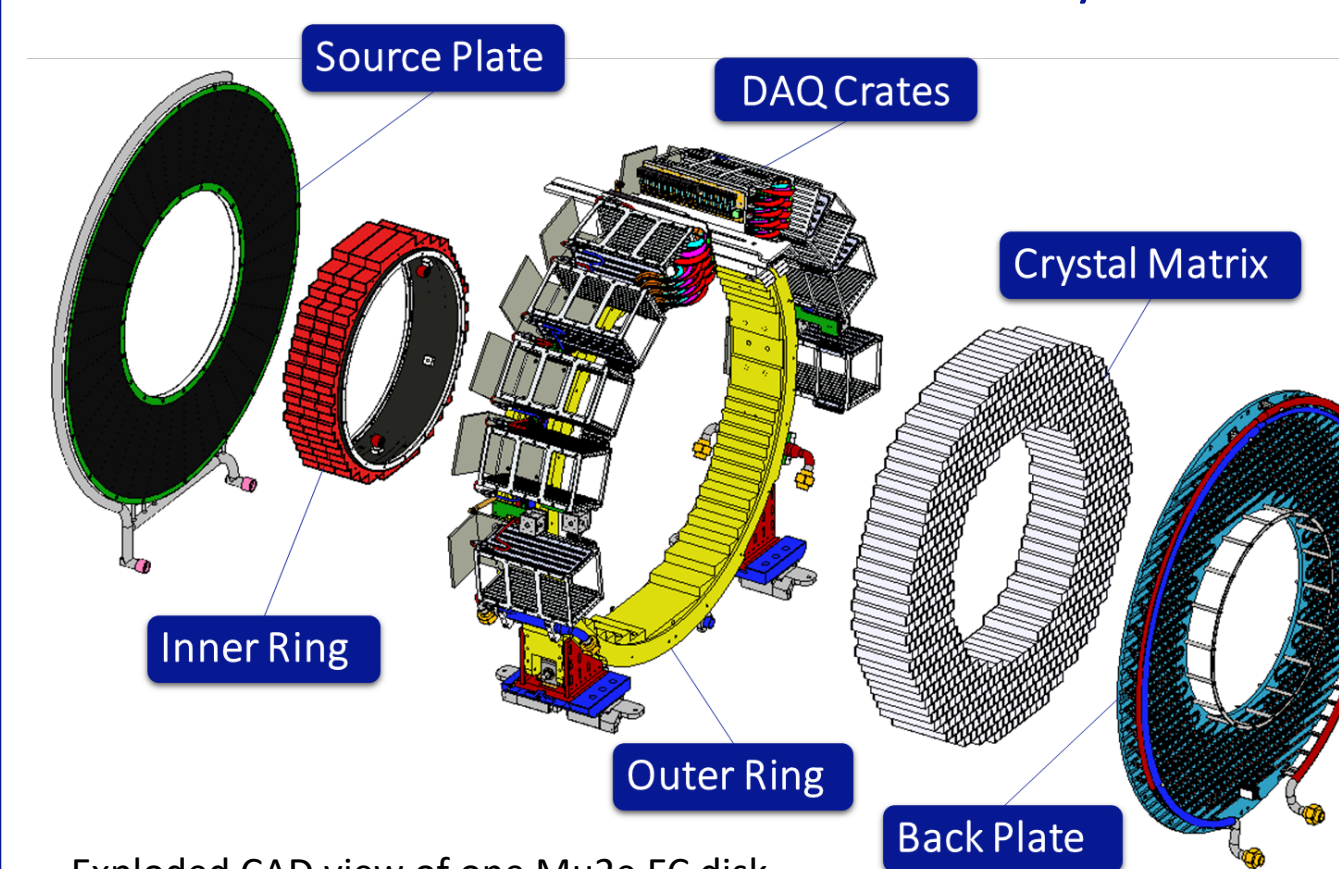

The crystal matrix is supported by the aluminum Outer Ring from outside and by the carbon fiber Inner Ring from inside. Ad hoc alignment tools embedded in the Outer/Inner Rings allow to fine tune the crystals positions.

The scintillation light is readout by large area UV-extended SiPMs (two 14x20 mm² SiPMs/crystal to improve operational reliability). The gigantic SiPM + FE Boards matrix is embedded in the Back Plate that also integrates a network of cooling lines to control SiPM and FE electronics temperature. DAQ boards are hosted in a battery of 10 crates/disk placed on the disk lateral surface.

A liquid radioactive source (Fluorinert) is fluxed through a network of pipes housed in the frontal Source Plate to provide an absolute energy scale and the response equalization among the crystals.

- | | | |
|---|---|---|
| Calorimeter Requirements: | Calorimeter Performance: | Operational conditions: |
| <ul style="list-style-type: none"> Particle identification μ/e Seed for track pattern recognition Independent trigger | <ul style="list-style-type: none"> $\Delta E/E < 10\%$ and $\Delta t < 500$ ps Position resolution of O(1 cm) | <ul style="list-style-type: none"> 1 T B-field 10^{-4} torr 90 krad, 10^{12} n cm⁻² year⁻¹ 25°C |

3. The matrix of Cesium Iodide Crystals

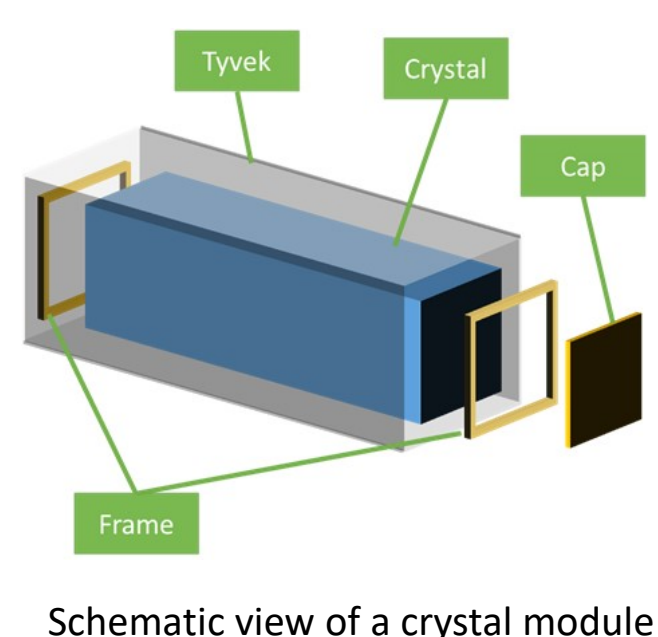

Schematic view of a crystal module

The 674 CsI crystals (34x34x200 mm³) are arranged in a "donut"-shaped matrix (internal/external diameter of 650 mm/1314 mm).

Crystals are wrapped in Tyvek foils (150 μ m thick) to improve internal light reflection and separated with Tedlar foils (50 μ m thick) to minimize cross-talk.

Thorough QA of production crystals was performed: they all satisfy a linear dimensional tolerance below 0.1 (short side)/0.2 (long side) mm and a \perp perpendicularity below 0.1.

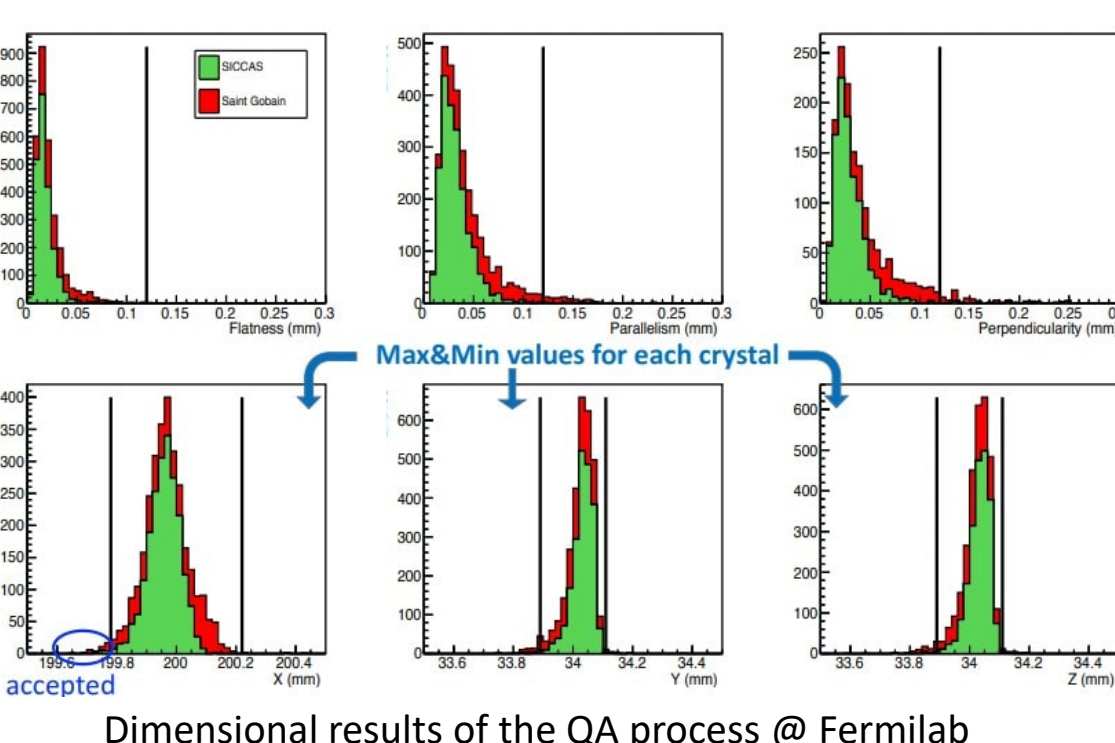

Dimensional results of the QA process @ Fermilab

We performed a series of vertical/horizontal crystals stacking tests to develop a model and predict crystal positions in the donut-shaped matrix (where will crystal(i,j) be located in the real detector?).

For maximum flexibility, Inner/Outer Rings embed tools for a residual fine-tuning of the crystal positions and alignment with the SiPMs matrix.

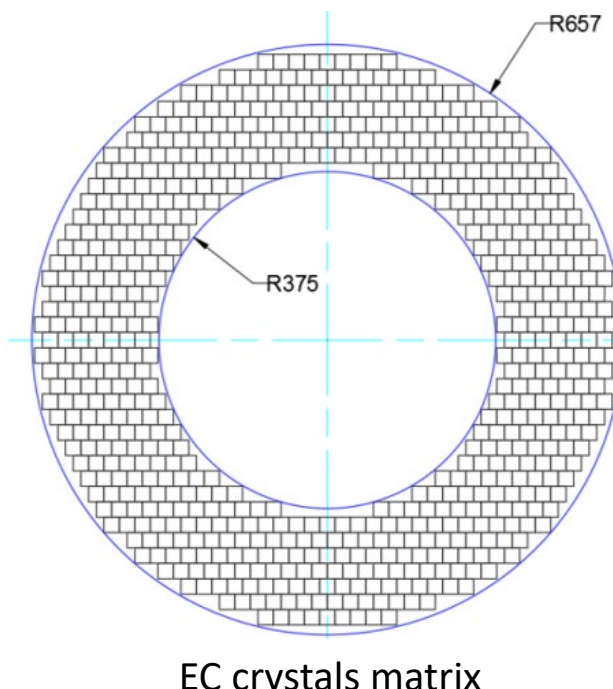

EC crystals matrix



Crystal vertical piling up measurement test

5. The Back Plate

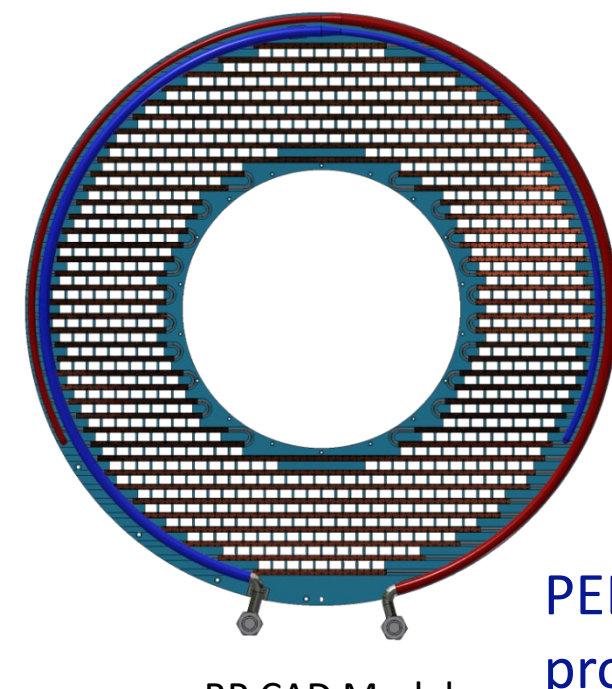

BP CAD Model

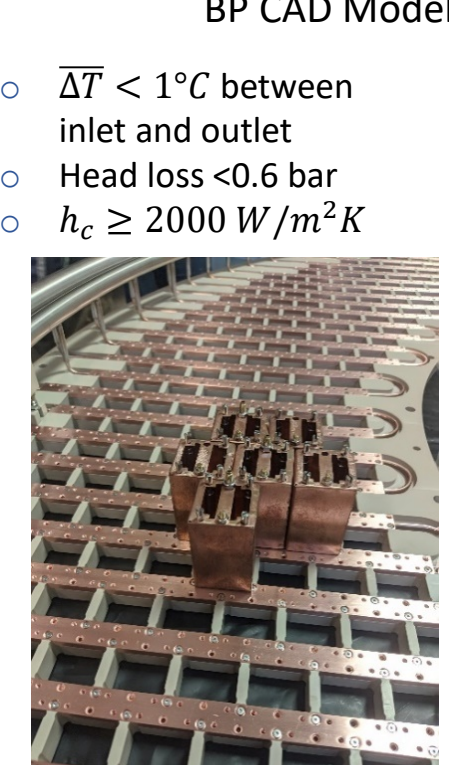

FEE Modules mounted on the BP

The Back Plate provides the mechanical support to the SiPM + FE electronics along with a reference system for the crystal matrix alignment. It integrates also a network of cooling lines which allows to refrigerate the SiPM and FE electronics. SiPM can be thermalized down to -10°C (if necessary) to minimize dark current and have a stable signal over the three years of data taking.

PEEK was chosen for its good thermal insulation and outgassing properties. Two stainless steel (AISI 316L) I/O manifolds placed on the external border distribute the cooling fluid (3M Novec 649) among the network of 38 parallel copper cooling lines embedded in the PEEK. The two Back Planes had been completely manufactured by Cinel and delivered to INFN. Geometrical, thermal and integration surveys will be performed before shipping to Fermilab.

The (674) SiPM+FEE modules are mainly composed of 2 SiPMs glued on a copper holder, 2 FE boards and a copper protective cage. The modules are fastened directly on the Back Plate Cooling lines to optimize thermal conductivity.

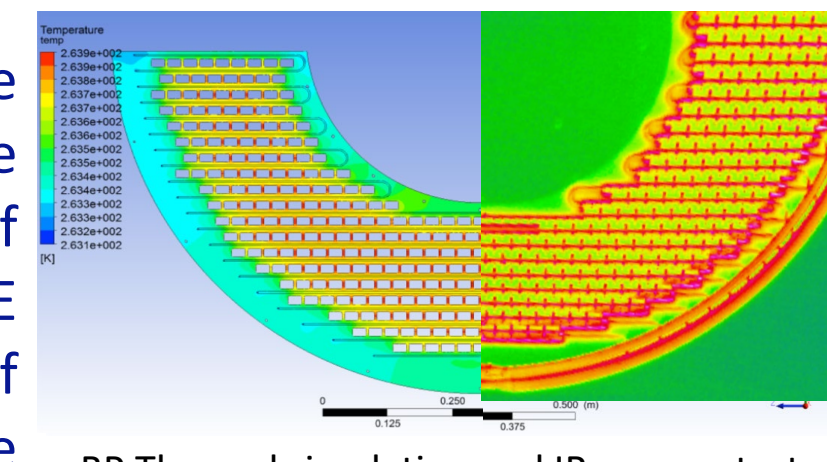

BP Thermal simulation and IR camera test



BP leak tests



FEE holders with glued SiPMs

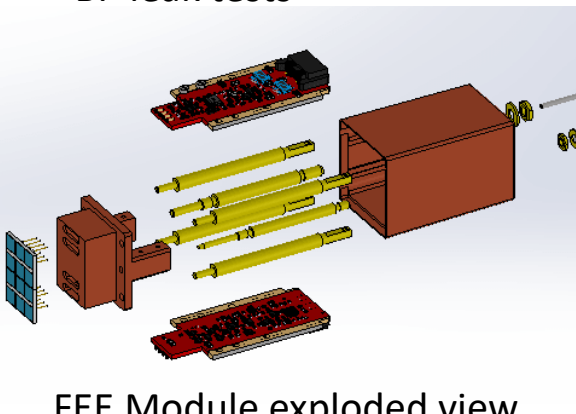

FEE Module exploded view

6. The DAQ Boards and Crates

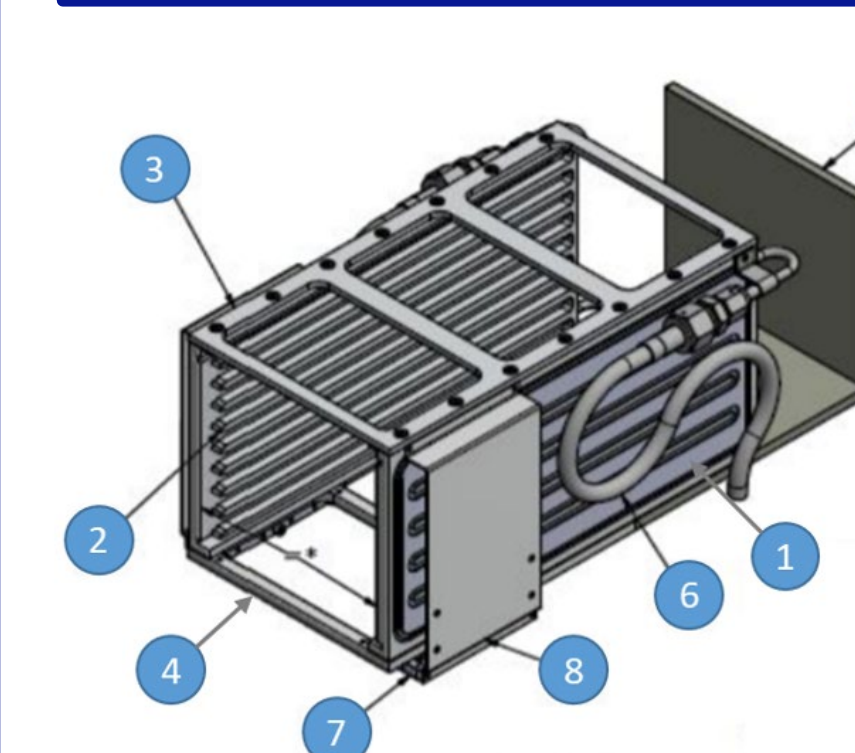

Crate CAD model

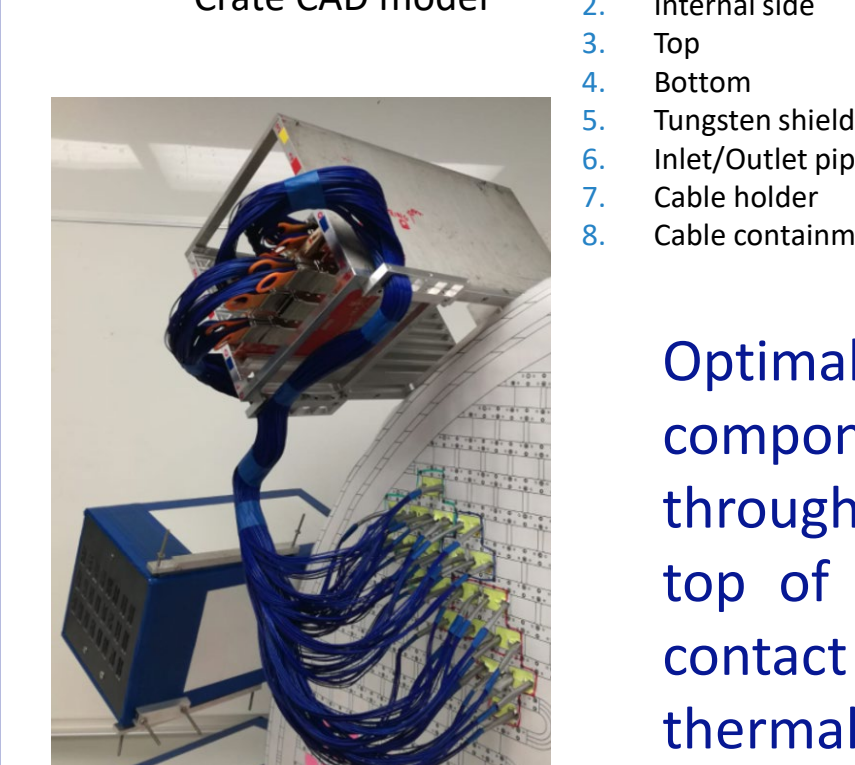

FEE cable mock-up

10 crates placed on the lateral surface of the disk host 80 DAQ boards which digitize and transmit the data received from the FEE through optical fibers out of the cryostat to the central DAQ system. Each crate integrates a network of cooling lines to remove the 320 W dissipated by the set of 8 DAQ boards. To reduce envelopes and optimize the system performance, the cooling lines are directly carved in the crate sides.



Crate sides during leak test



MB and Dirac coupled with copper plates

Optimal thermal contact between the electronic components and the heat sink is achieved through a machined copper plate positioned on top of the DAQ board and placed in thermal contact with the components with vacuum proof thermal grease (Apiezon).

The DAQ crate structure is completed by a set of tungsten plates which protect the electronic components from the high level of radiation present in experimental area at run time.

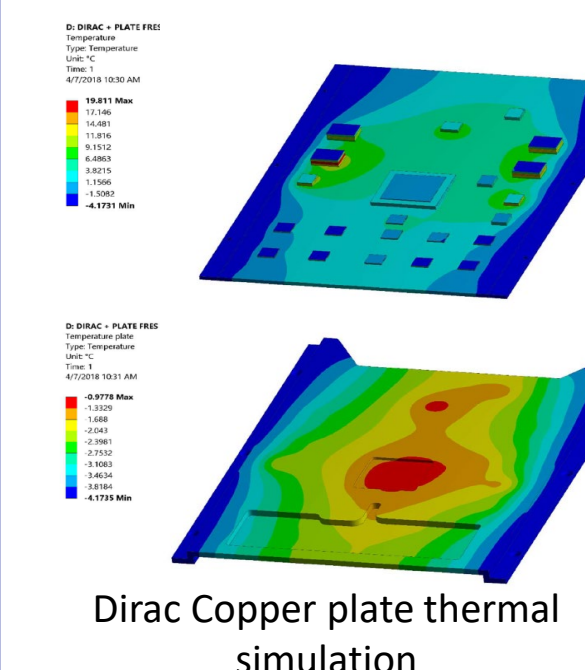

Dirac Copper plate thermal simulation

Thorough thermal simulations and tests have been performed in air as well as in vacuum to crosscheck the cooling system performance. DAQ crates production is now progressing rapidly.

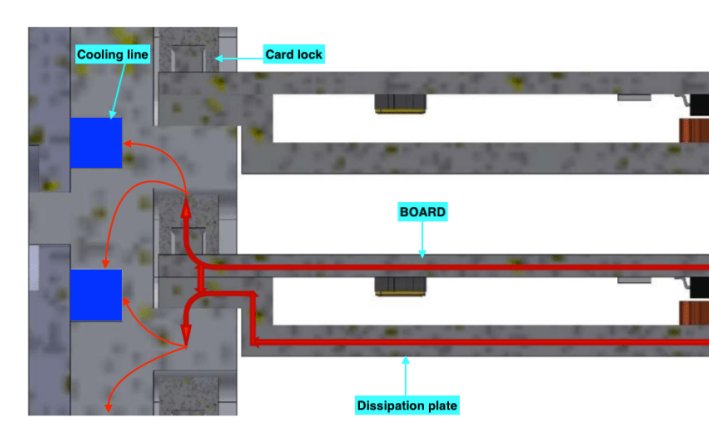

Board heat flux path schematic

4. Composite Materials: the Source Plate and the Inner Ring

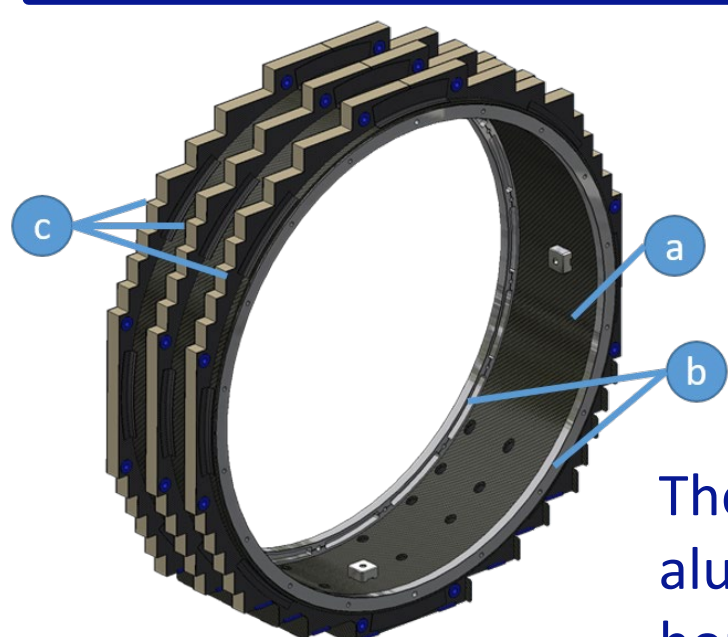

Inner Ring CAD model

The materials choice/budget of the mechanical structures traversed by the particles have been optimized to minimize the particles energy loss. The Source Plate and Inner Ring are made of carbon fiber planes strengthened by light aluminum structures when necessary.

The IR is made of a carbon fiber cylinder stiffened by two aluminum rings and three supporting ribs with honeycomb structure. The IR is supported by the Back Plate and Source Plate and provides the internal vertical/horizontal reference of the crystals matrix: mobile feet allow to adjust the IR position.

Compression tests suggested to implement also protection measures to prevent crystal surface damages.

The SP is made of a carbon fiber honeycomb sandwich with an embedded aluminum pipe to flow the radioactive CF-770 calibration source. The SP will also support a frontal enclosure for crystals protection.

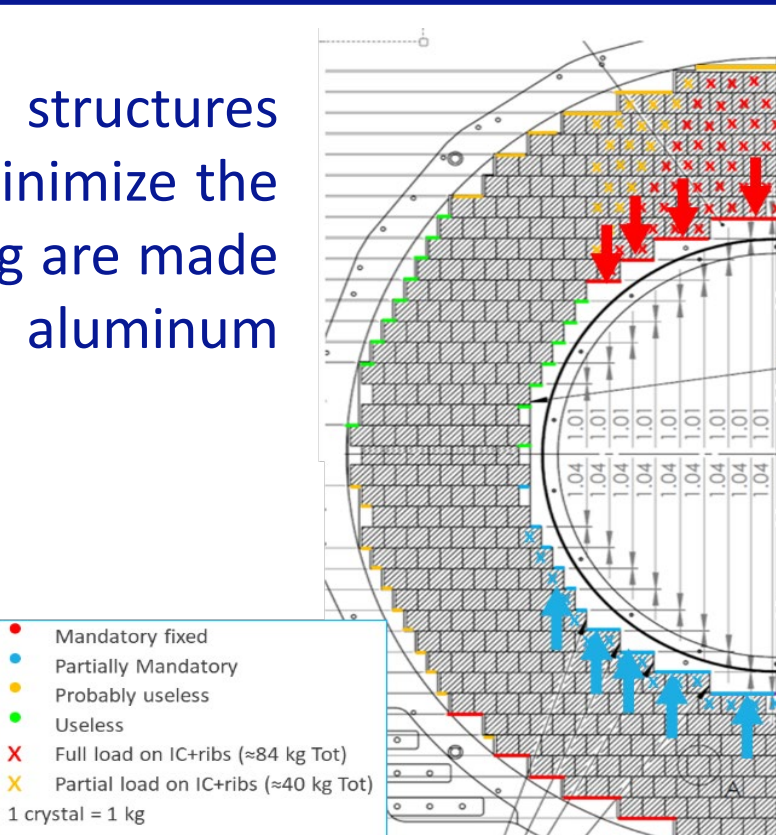

Vertical load scheme for the IR

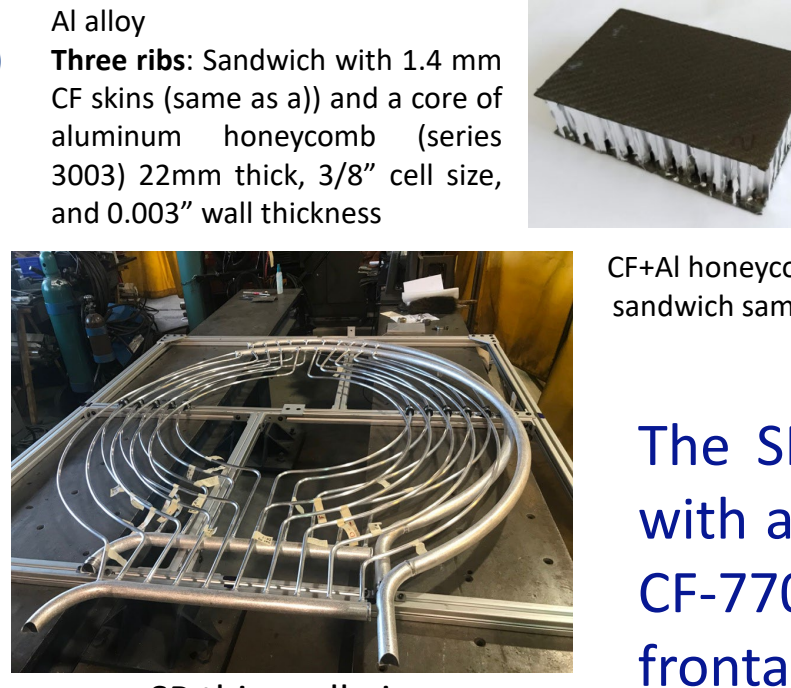

CF+Al honeycomb sandwich sample and SP thin wall pipes

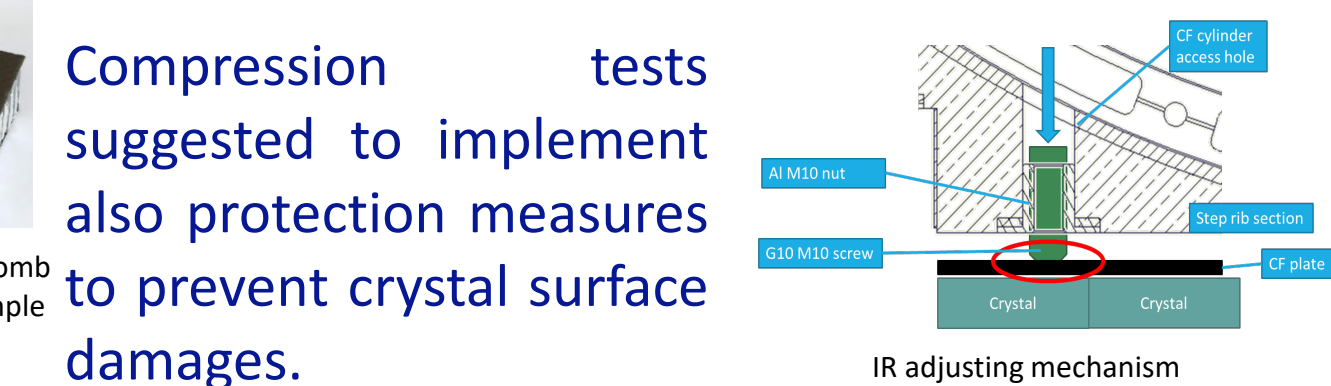

IR adjusting mechanism

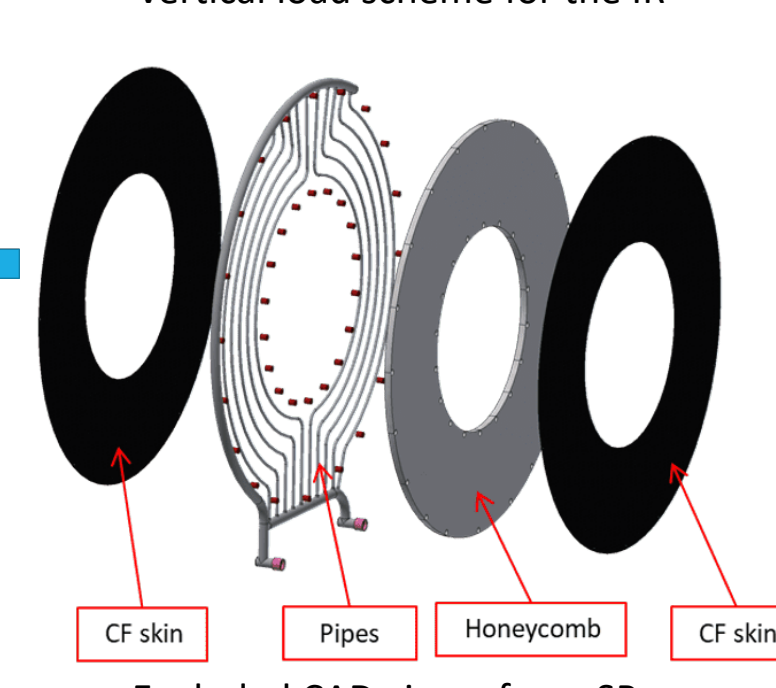

Exploded CAD view of one SP

7. Plans for Detector Assembly



Calorimeter assembling cleanroom @ SiDet Lab

- The calorimeter will be assembled in a 10000-class cleanroom built in the SiDet Laboratory at Fermilab.
- Two assembly stations will be available to test the first assembled disk while building the second one.

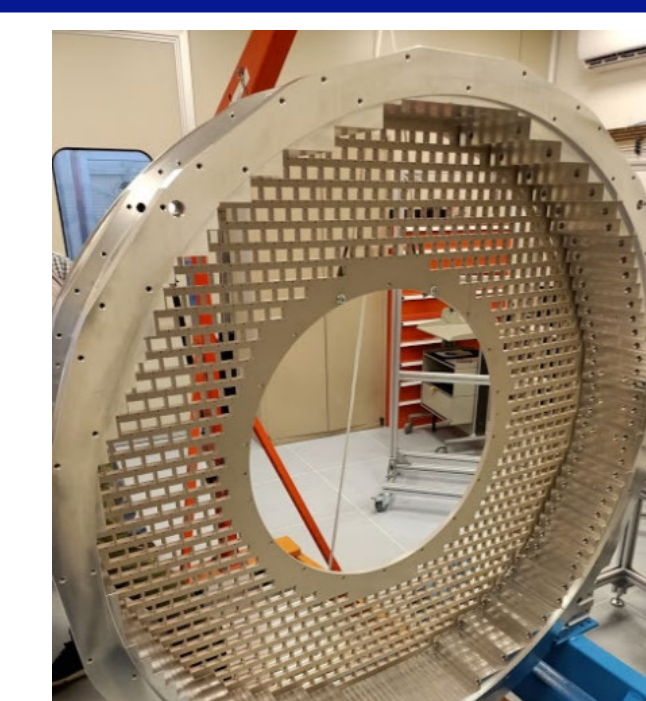

Outer Ring coupled with the Backplate @ LNF



Outer Ring mounted on assembling stand @ SiDet Lab

- Outgassing test of the components will be performed before assembly in dedicated vessels (the most critical components are crystals and cables).
- The alignment of the crystals matrix will be continuously monitored during detector assembly.
- Tests of the cooling system and electronic components will be continuous during and after detector assembly.

This work was supported by the US Department of Energy; the Italian Istituto Nazionale di Fisica Nucleare; the US National Science Foundation; the Ministry of Education and Science of the Russian Federation; the Thousand Talents Plan of China; the Helmholtz Association of Germany; and the EU Horizon 2020 Research and Innovation Program under the Marie Skłodowska-Curie Grant Agreement No. 690385_734303_822185_858199_101003460. Fermilab is operated by Fermi Research Alliance, LLC under Contract No. De-AC02-07CH11359 with the US Department of Energy.



8. Conclusions

- Mu2e EM calorimeter mechanical design finalized
- It took many years of prototyping and engineering to be here today!
- Most calorimeter mechanical structures already built and tested
- Some parts still being built, but they are not far in time
- Crystals, SiPMs production completed, FEE, cables and DAQ boards under production
- Looking forward to start assembly in fall!



Mu2e experimental site in construction @ Fermilab

contact email: daniele.pasciuto@pi.infn.it