

# Direct dark matter search: status and plans



Adam Brown

University of Sheffield

IOP HEPP and APP Meeting 09/04/25

[adam.m.brown@sheffield.ac.uk](mailto:adam.m.brown@sheffield.ac.uk)



University of  
Sheffield

**Dark matter halo**

**What's it made of?**

**Cambridge**



# The case for dark matter

Widespread indirect evidence for mass beyond the baryonic matter in the Universe

## Rotation curves

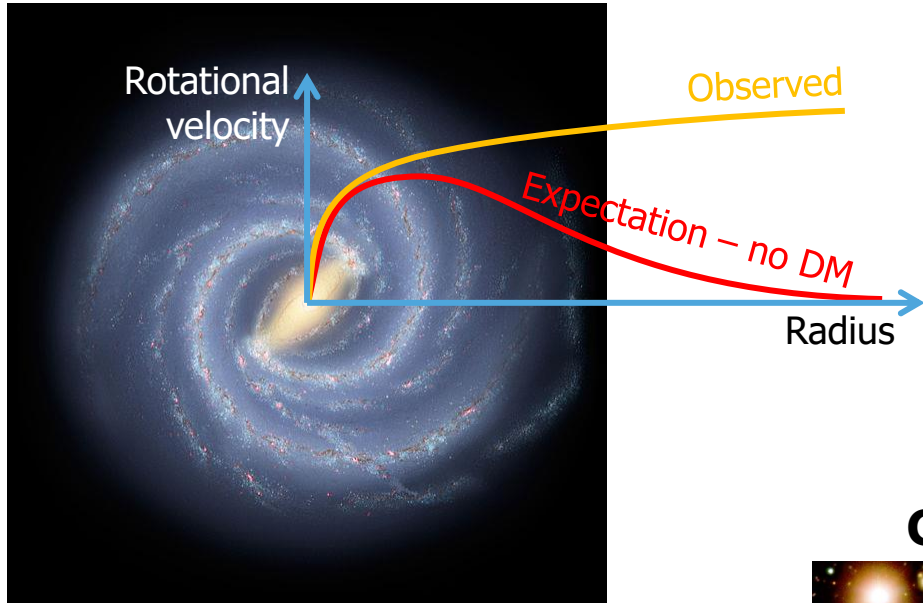

## CMB fluctuations

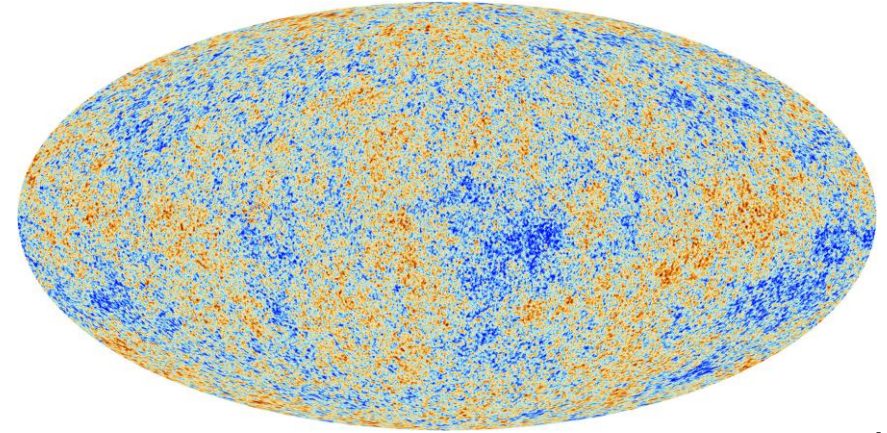
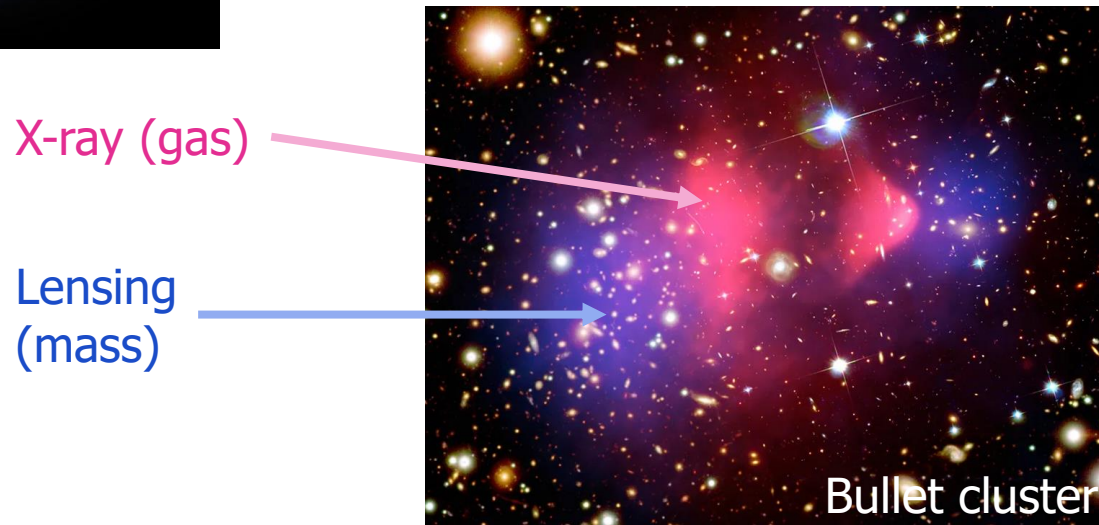

Image: ESA/Planck

## Gravitational lensing



Bullet cluster  
Image: NASA



# What is dark matter?

## Standard Model

Dark Energy

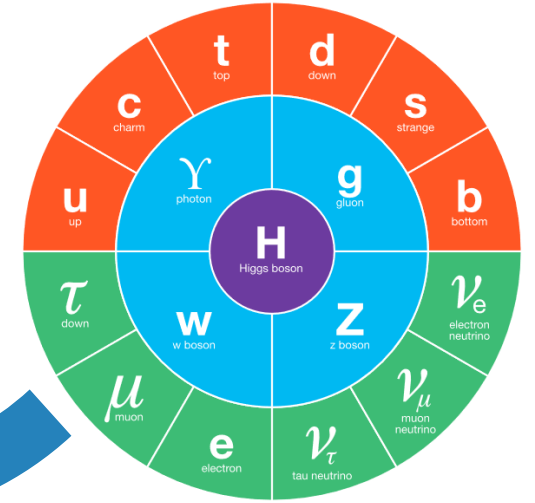
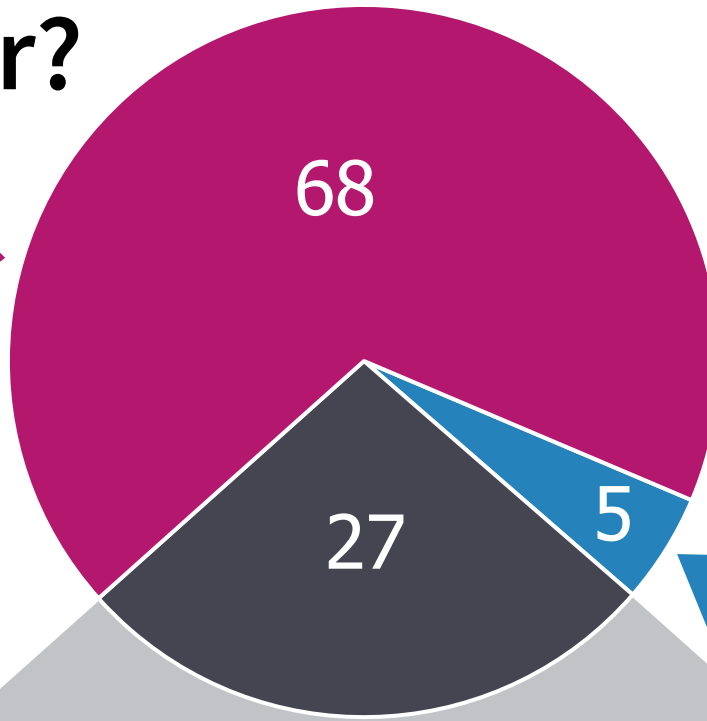

Plenary on Tue by David Marsh

Today's talk

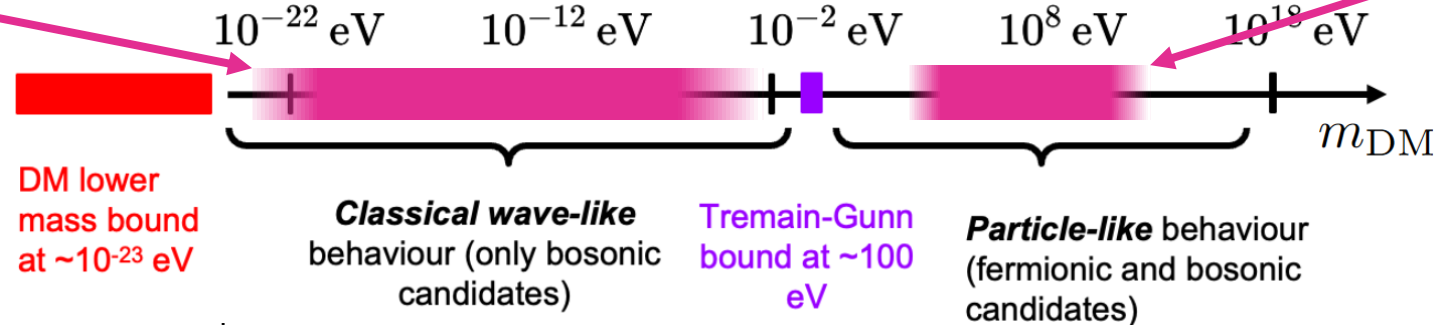

# Searches for dark matter

**This talk**

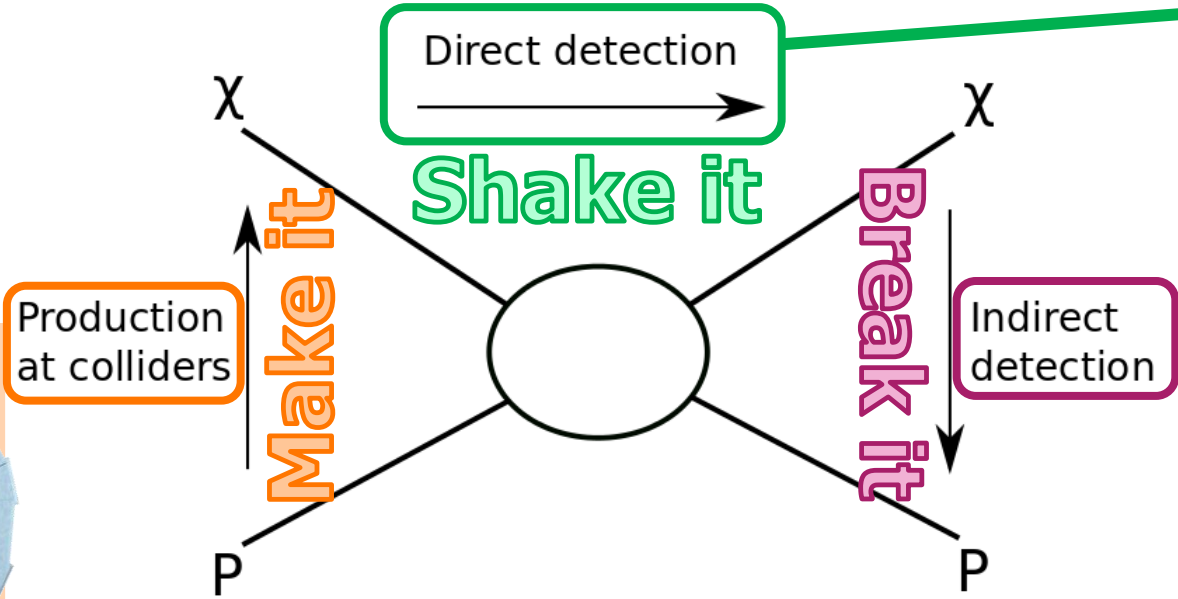
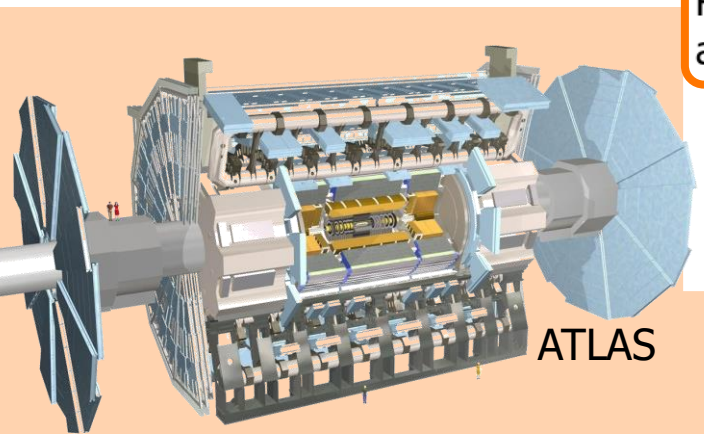

Search for annihilation products from Milky Way halo

Difficult due to astrophysical backgrounds

Look for missing  $p_T$

Difficult to know abundance of any particle discovered

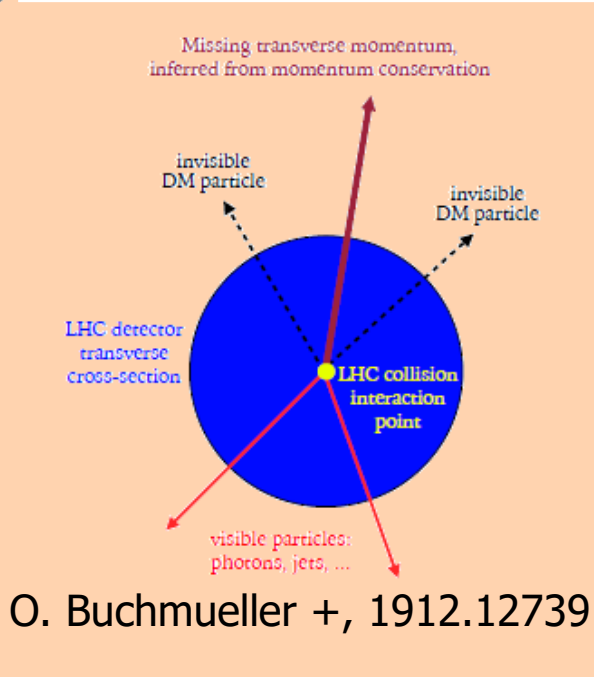

Picture by NASA



Picture by H.E.S.S. collaboration

# Direct detection – WIMPs

Look for scattering off nuclei

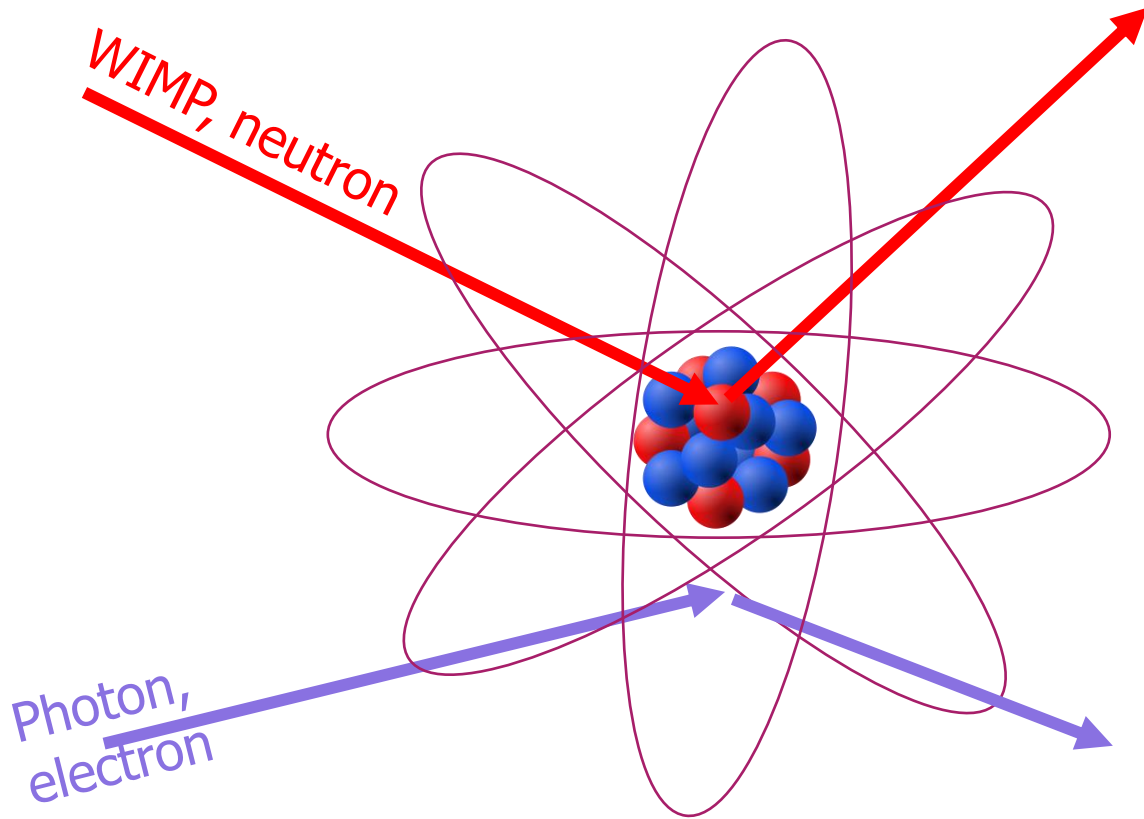

Detect energy deposit (charge / light / heat)

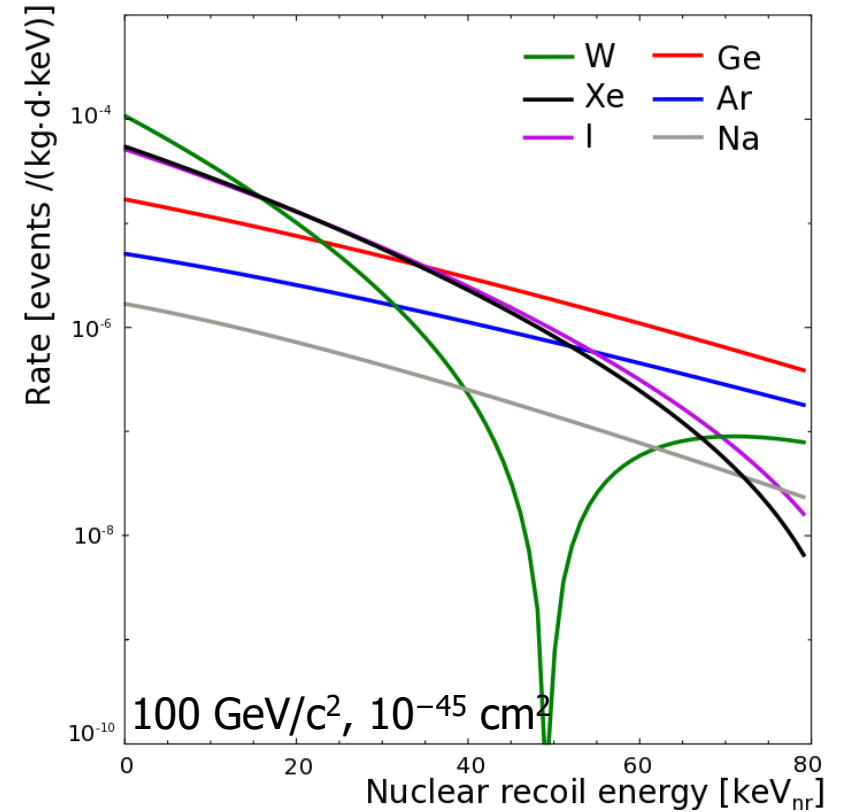

T. Marrodán Undagoitia & L. Rauch 1509.08767

# Direct detection – WIMPs

(Spin-independent scattering)

Low rates

→ Need large exposure, low background

Coherent scattering off nucleus as a whole

→ Rate scales with  $A^2$

Exponentially falling spectrum and low energies

→ Need low threshold

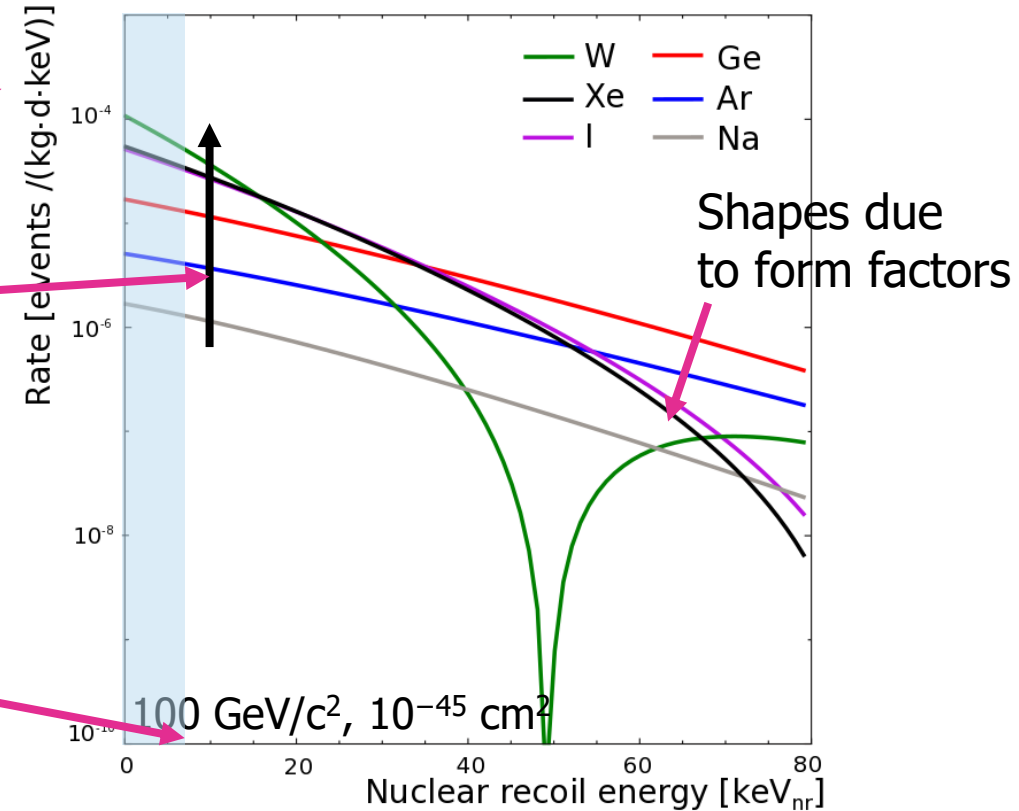

T. Marrodán Undagoitia & L. Rauch 1509.08767

# Signal readout

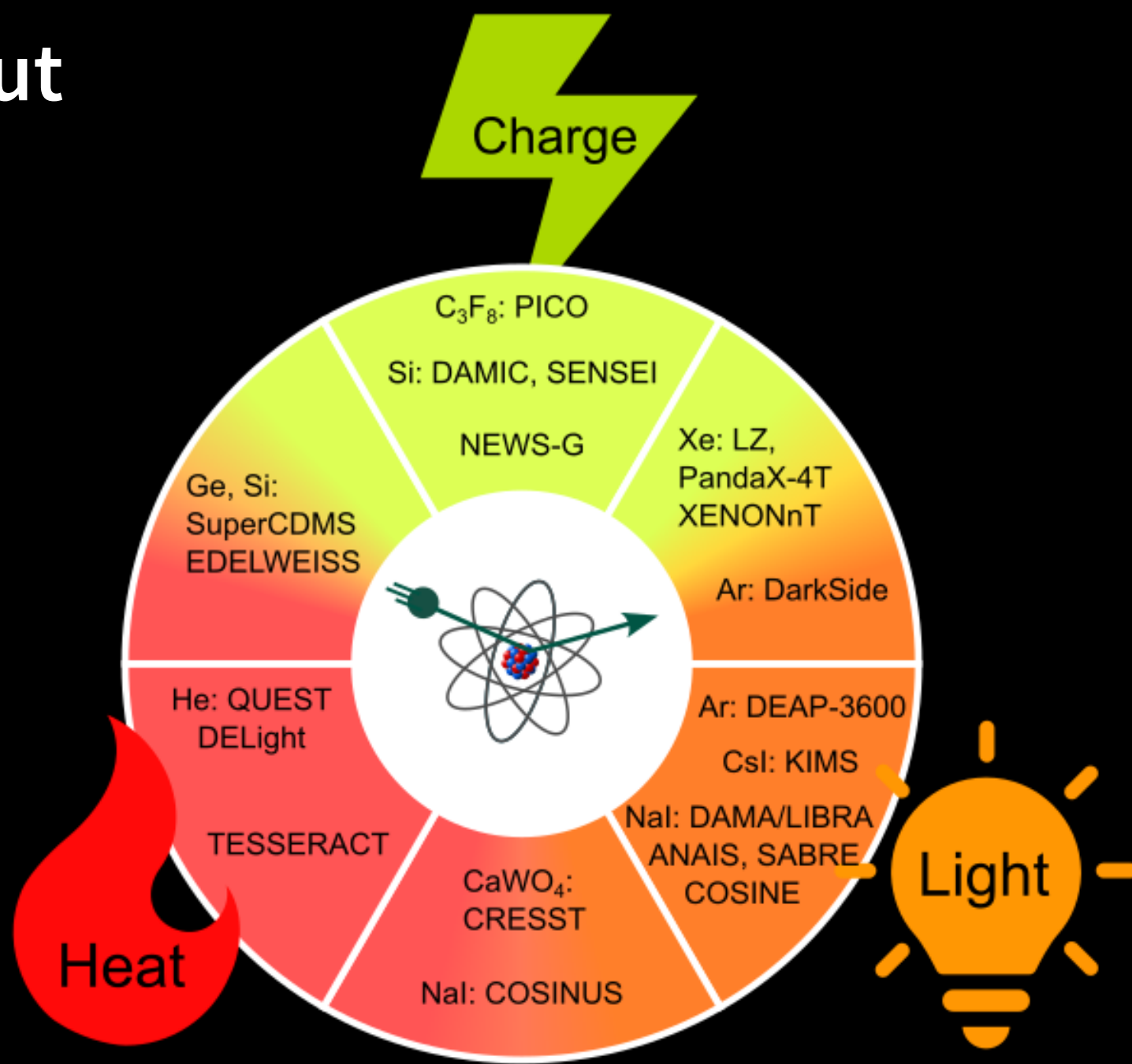

# Backgrounds

Muon-induced neutrons

p-p / B-8 neutrinos

High energy neutrinos (NR)

Neutrons from ( $\alpha$ , n) / fission

Material  
gammas

Intrinsic  
background  
( $\alpha$ ,  $\beta$ ,  $\gamma$ , n)

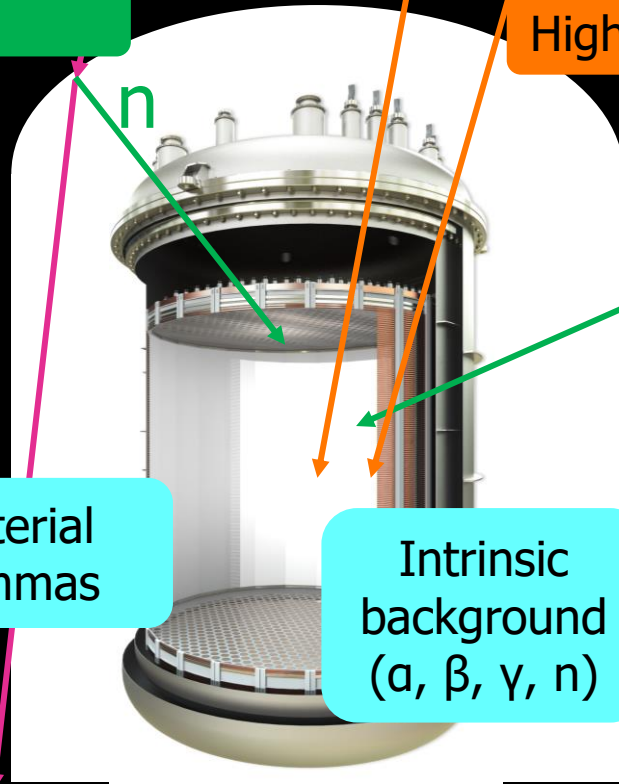

# Status of direct detection search

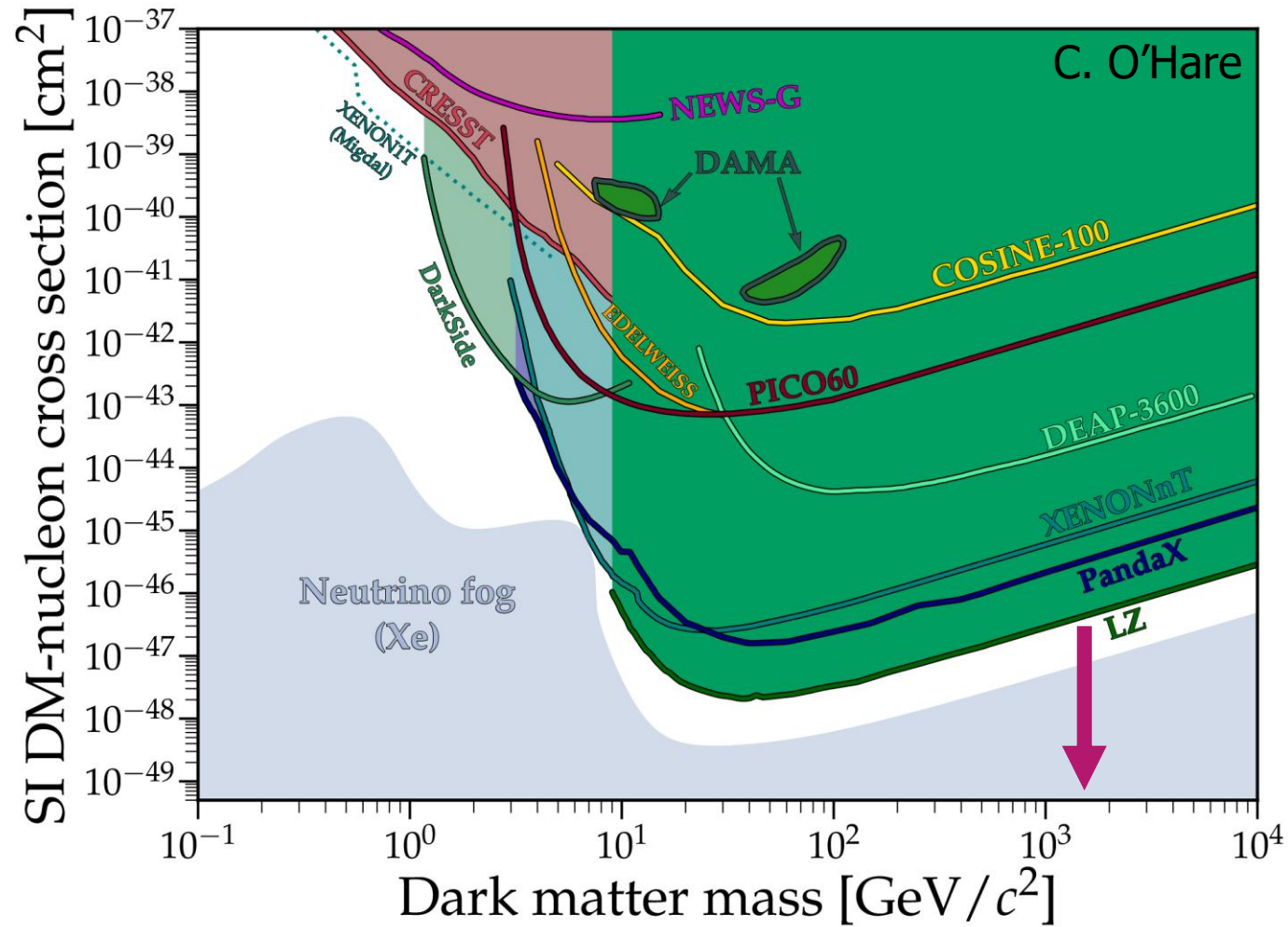

Larger, cleaner  
experiments

# Noble liquid detectors

## Single phase

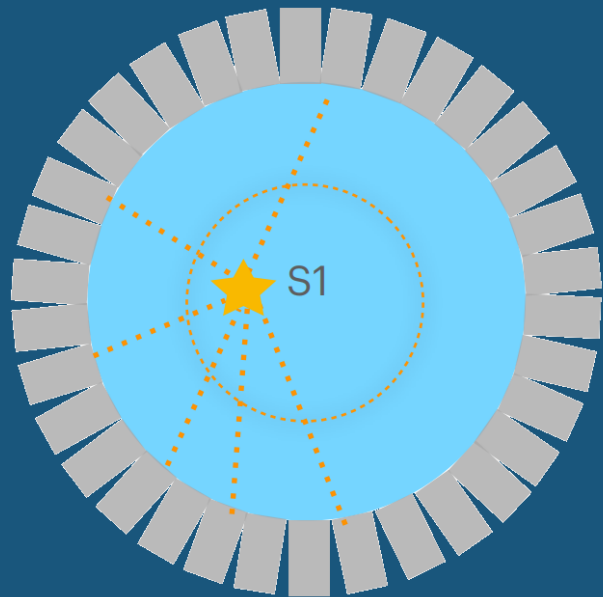

Light readout

Simple geometry  
High light yield  
No electric fields

## Dual phase TPC

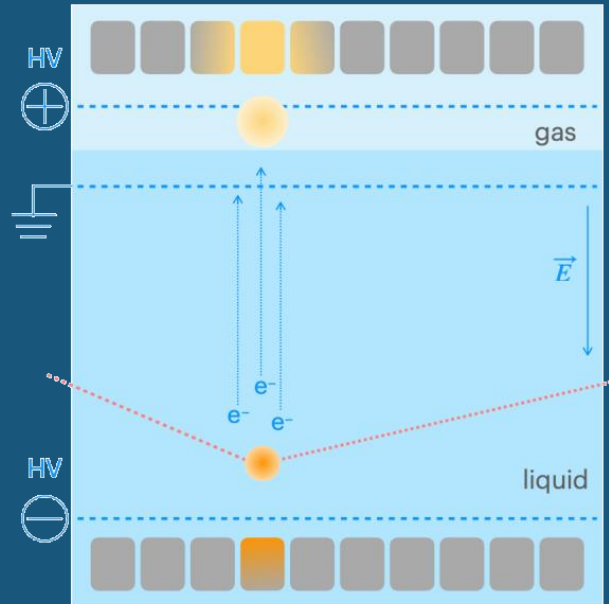

Light and charge readout  
Time projection chamber (TPC)

5D information ( $x, y, z, t, E$ )  
Good energy resolution  
Discrimination using charge:light

## Energy deposit

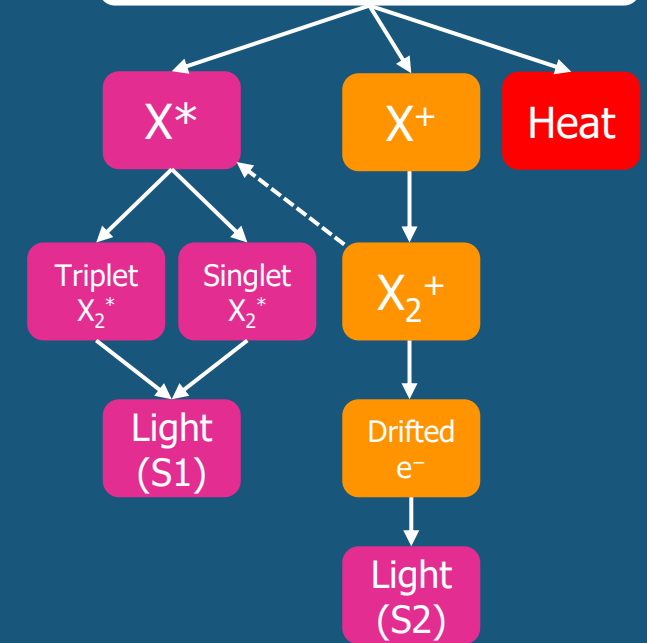

Singlet 3 ns (Xe), 10 ns (Ar)

Triplet 27 ns (Xe), 1500 ns (Ar)

# Liquid argon

ER-NR discrimination using pulse-shape at around  $10^{-10}$  level

Also possible with single-phase light-only detectors

Cosmogenic  $^{39}\text{Ar}$  significant background for current experiments

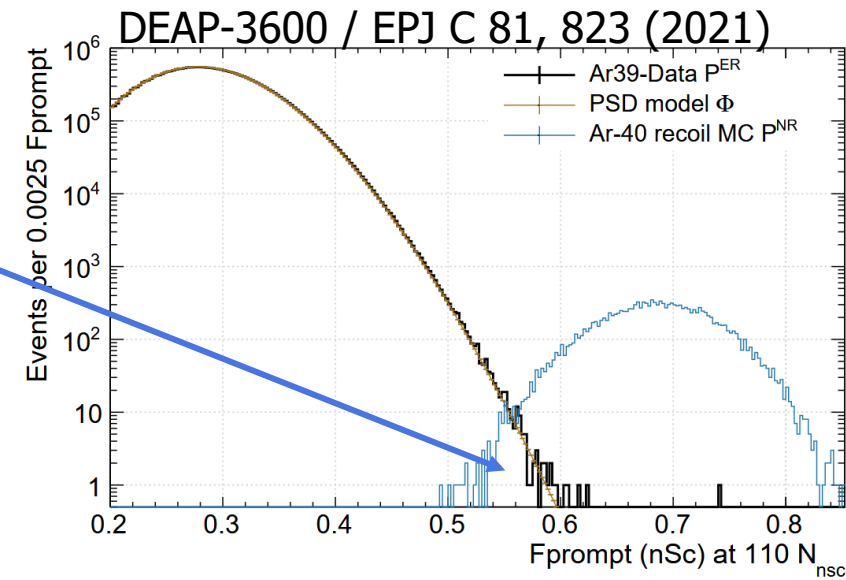

## DEAP-3600

SNOLAB, Canada

3 t LAr spherical design

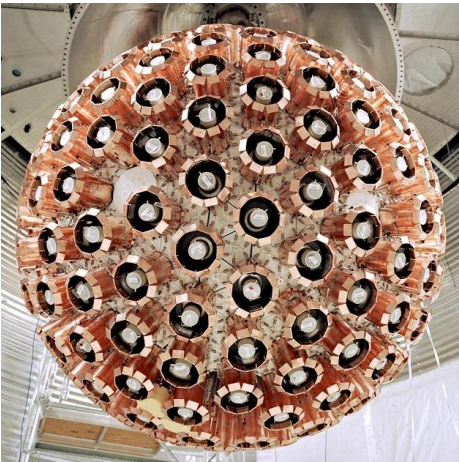

## DarkSide-50

LNGS, Italy

50 kg active LAr TPC

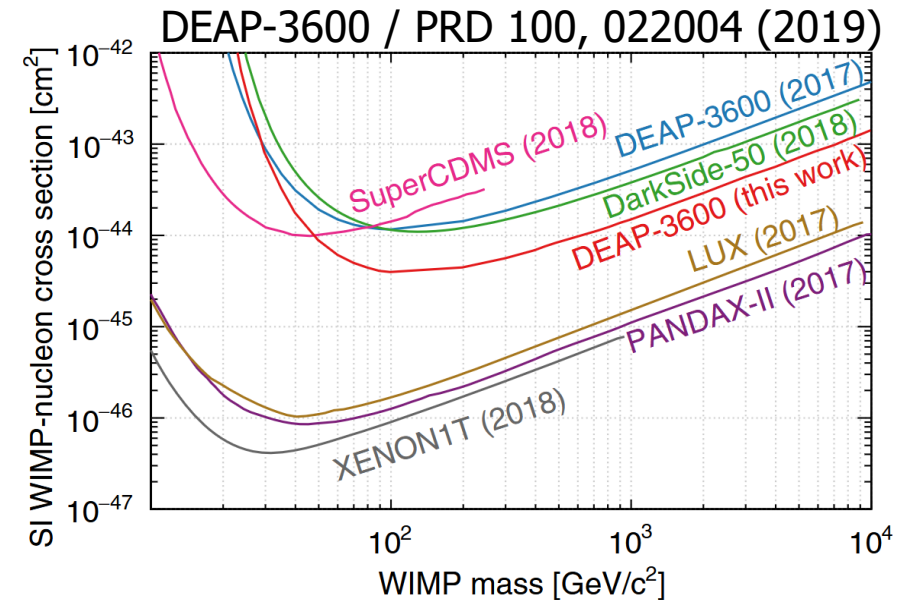

# Liquid xenon

Three current experiments  
 XENONnT (6 t), PandaX-4T (4 t) and LUX-ZEPLIN (7 t)

Current best limits for spin-independent WIMP scattering above few GeV

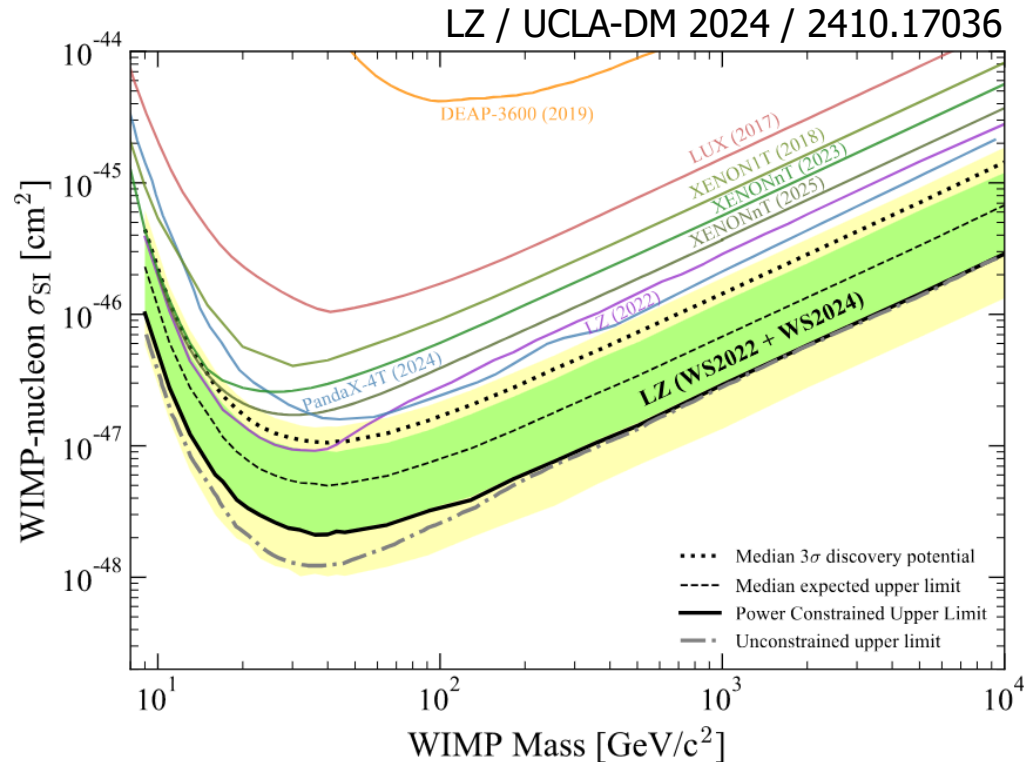

All three experiments use dual-phase LXe TPC

All currently taking data

Ultra-pure water shields and veto detectors surround TPC

XENON, LNGS, Italy



LUX-ZEPLIN,  
SURF, USA



PandaX-4T,  
CJPL, China

# Liquid argon – the future

Global Argon Dark Matter Collaboration brings together Ar community

**DarkSide-20k** under construction at LNGS, commissioning 2027

Two-phase TPC with 50 t instrumented argon

Underground-sourced argon (UAr) reduces <sup>39</sup>Ar  
→ Lower threshold, lower detector busy time

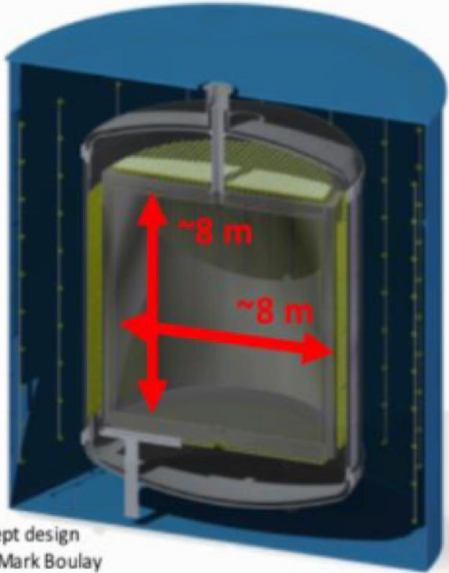
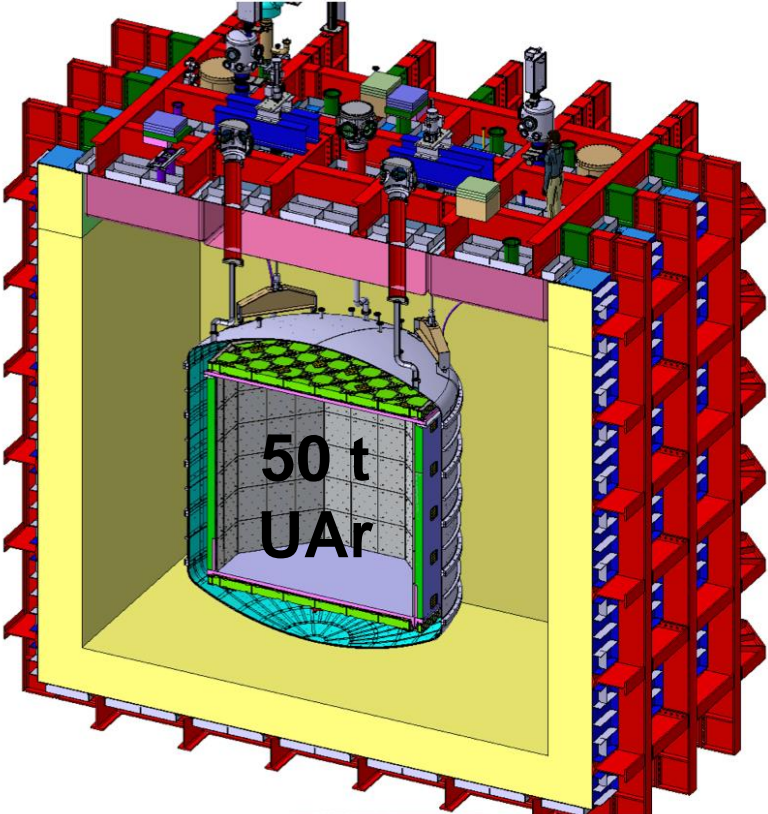
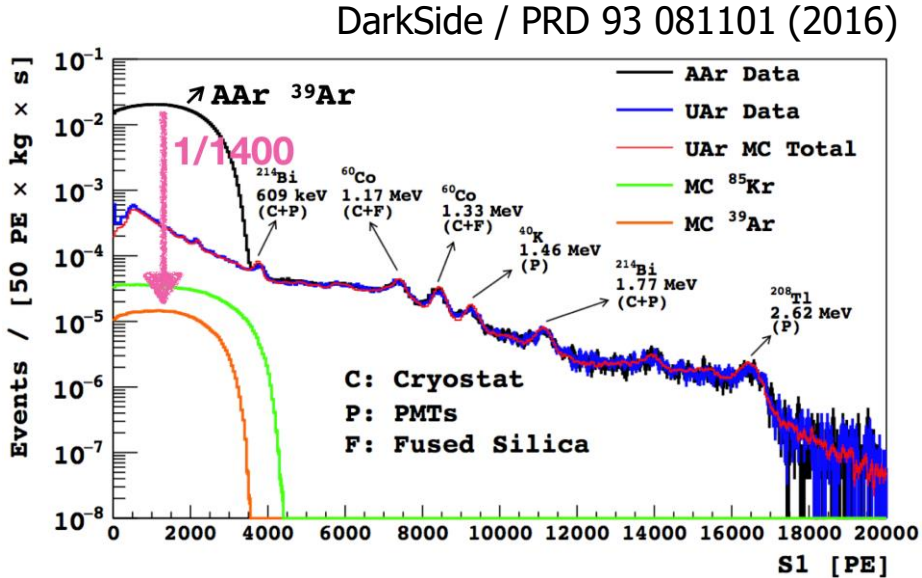

Concept design from Mark Boulay

ARGO: 400 t active TPC

# Liquid argon – the future

Global Argon D

DarkSide-20k u

Two-phase TPC

Underground-s  
→ Lower thres

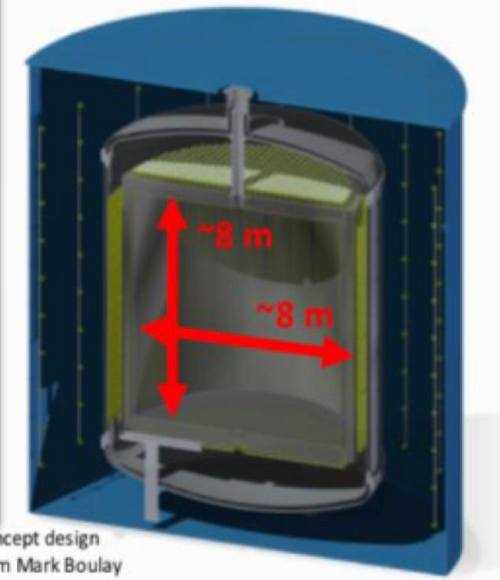
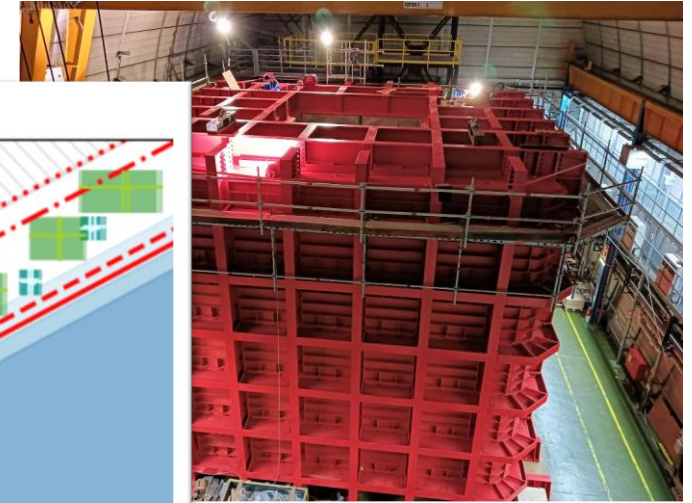
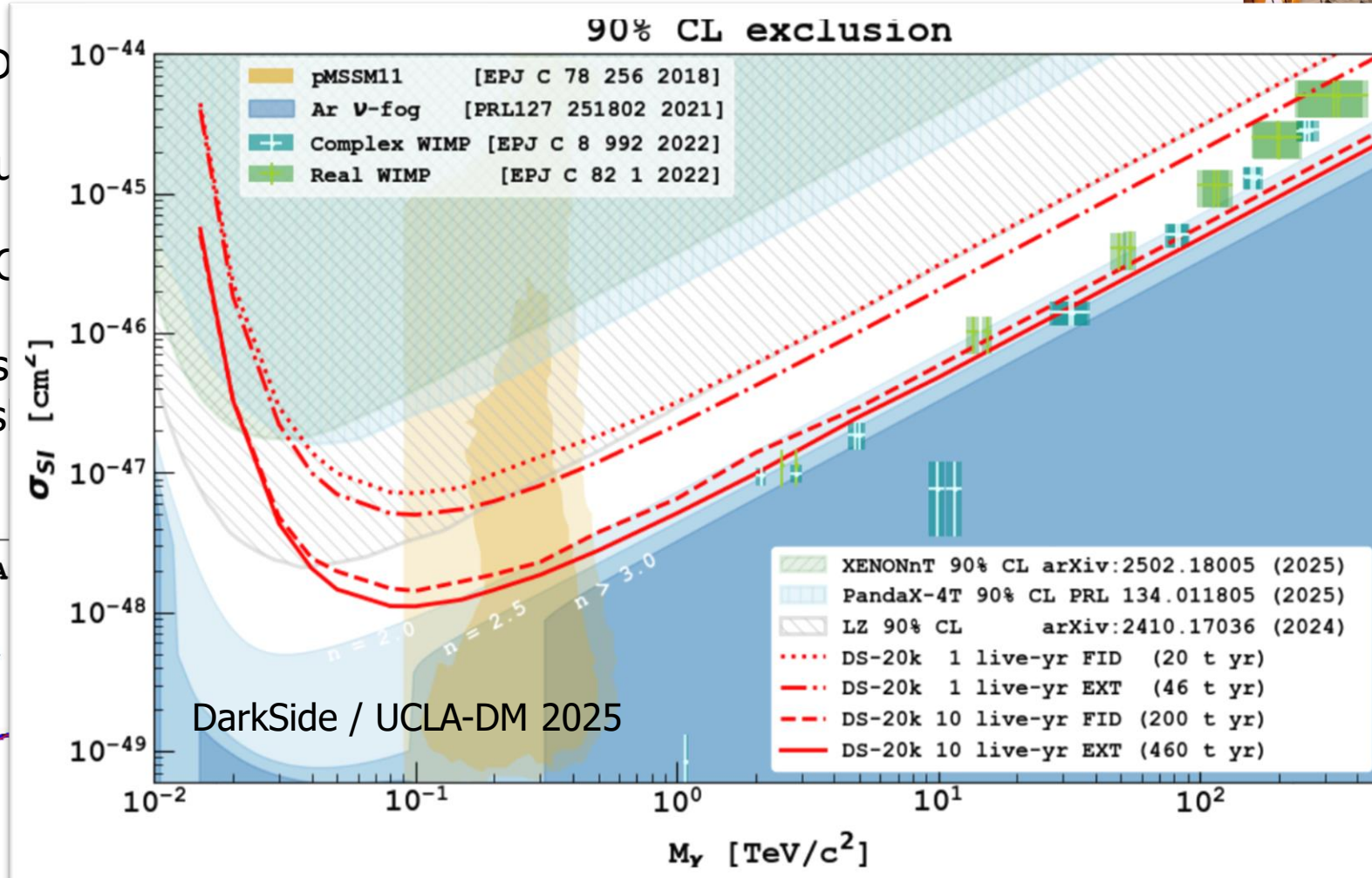
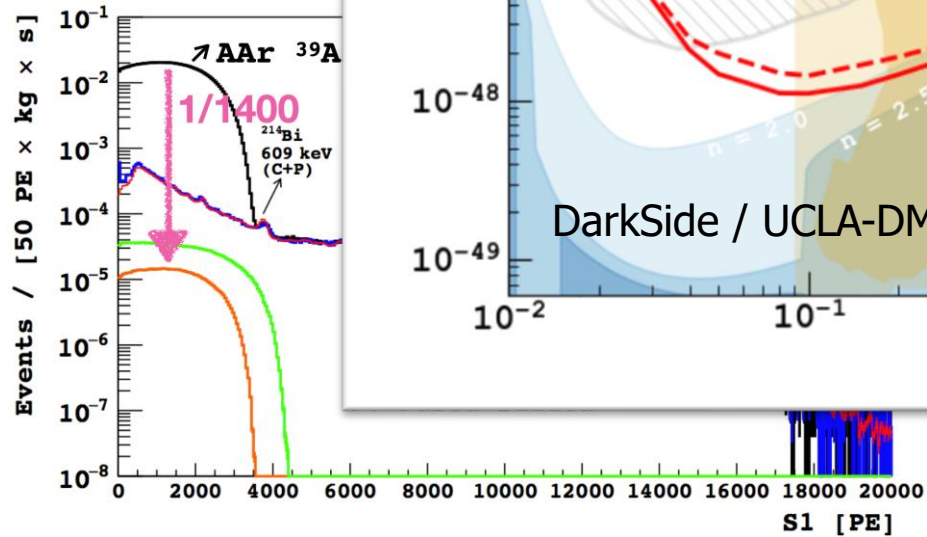

ARGO: 400 t active TPC

# Liquid xenon – the future

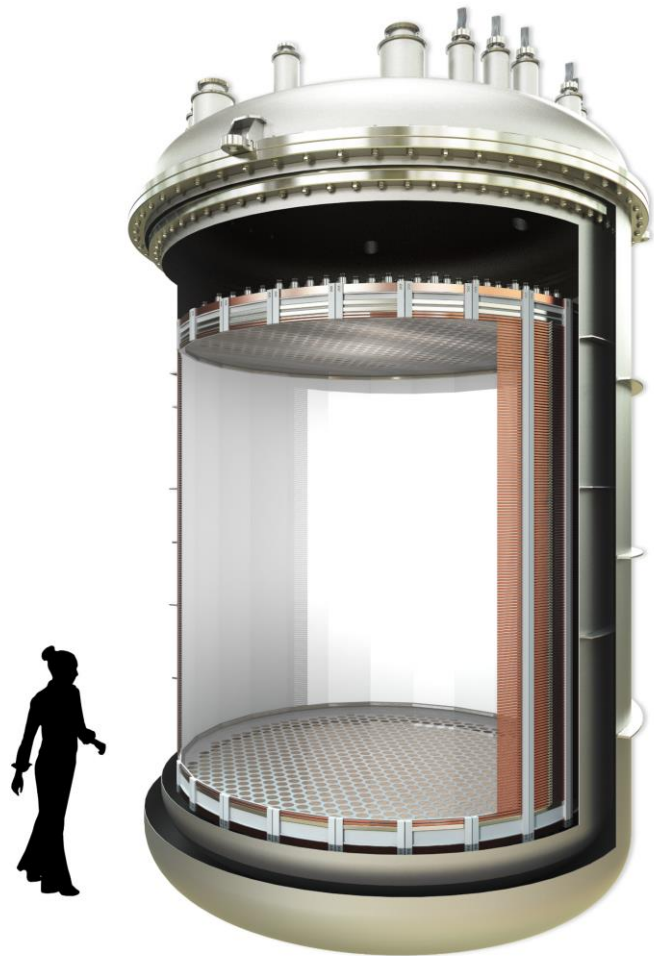

**XLZD**

XLZD collaboration brings together XENON, LUX-ZEPLIN and DARWIN

60–80 t active liquid xenon

Ongoing R&D and design work Especially in UK (XLZD@Boulby) and DARWIN R&D efforts

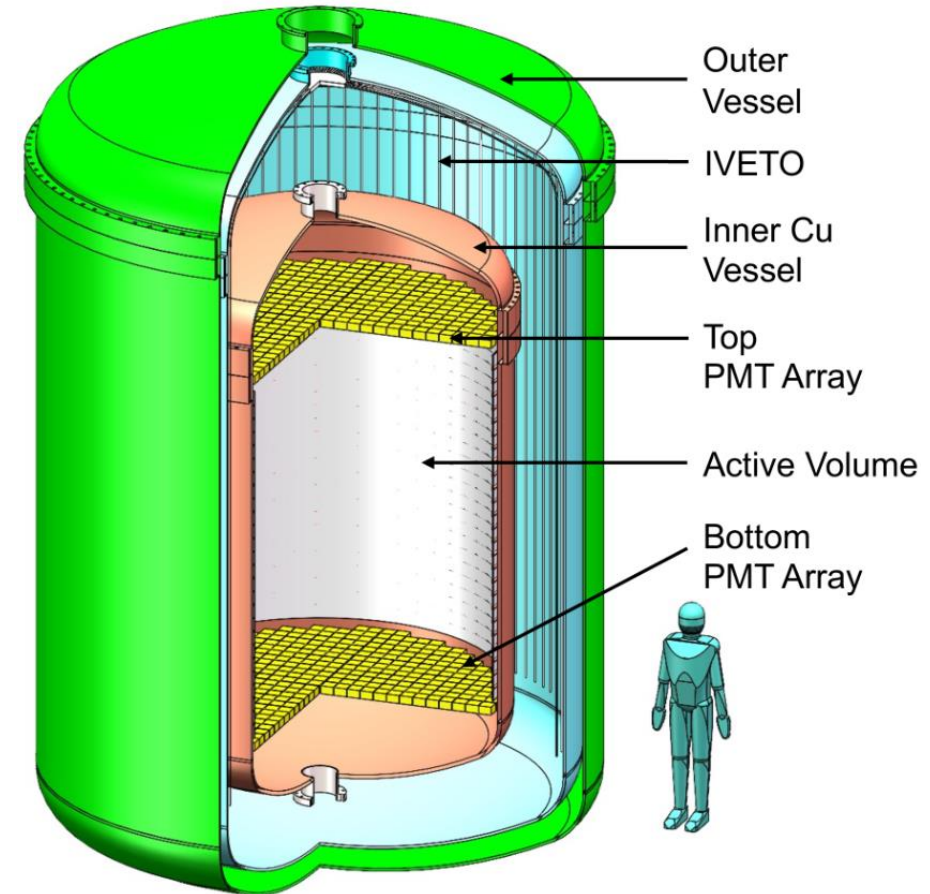

**PandaX-xT**

Pandax-20T intermediate stage commissioning planned 2027

# Liquid xenon – the future

**XLZD** will exclude all accessible WIMP parameter space above few GeV

3- $\sigma$  discovery potential at SI cross section of  $3 \times 10^{-49} \text{ cm}^2$  at 40 GeV

XLZD could be hosted in a purpose-built space at Boulby, UK

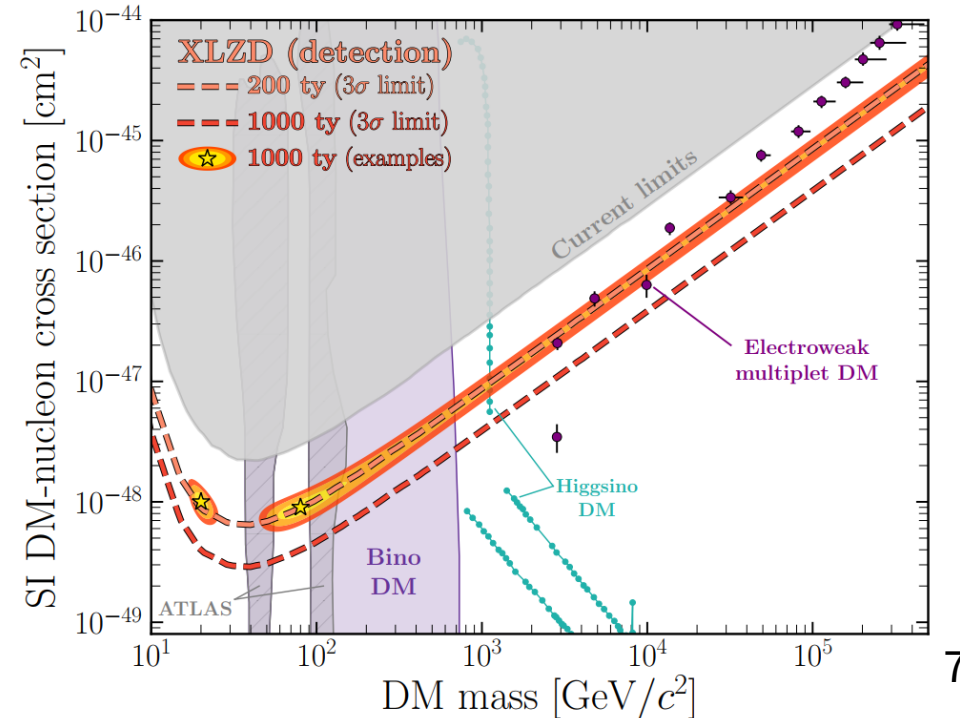
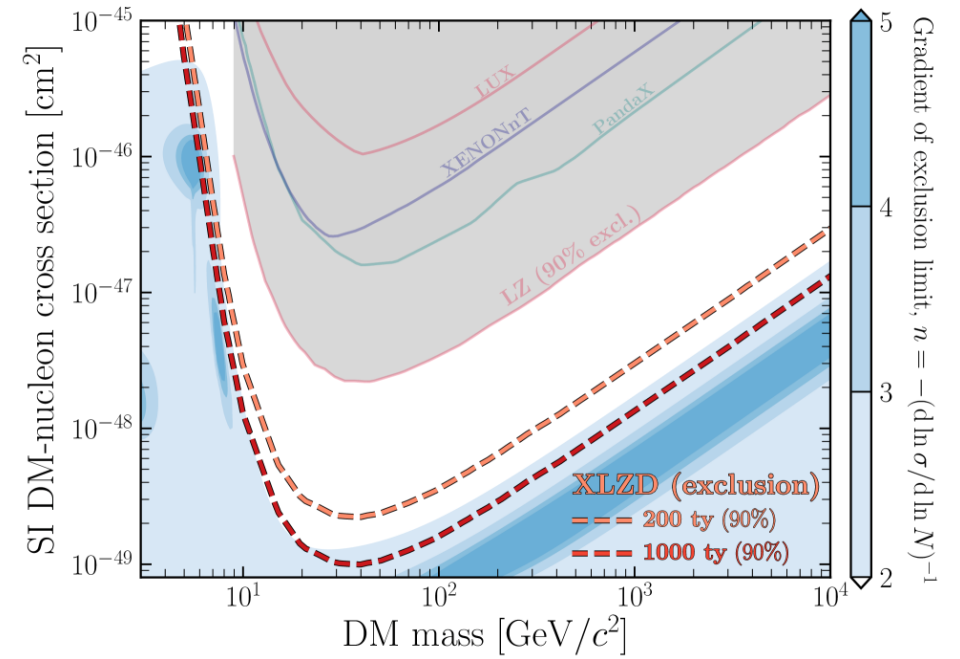
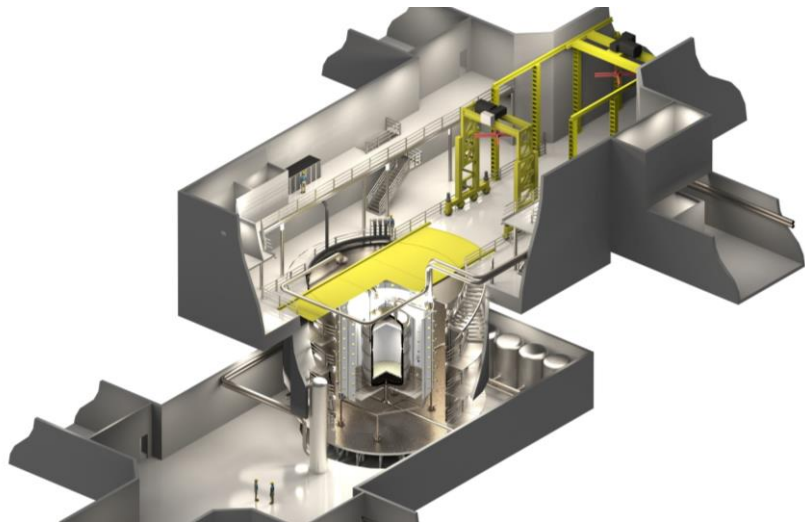

# Spin-dependent interactions

- So far focus on spin-independent WIMP scattering
- Can also look for spin-dependent process

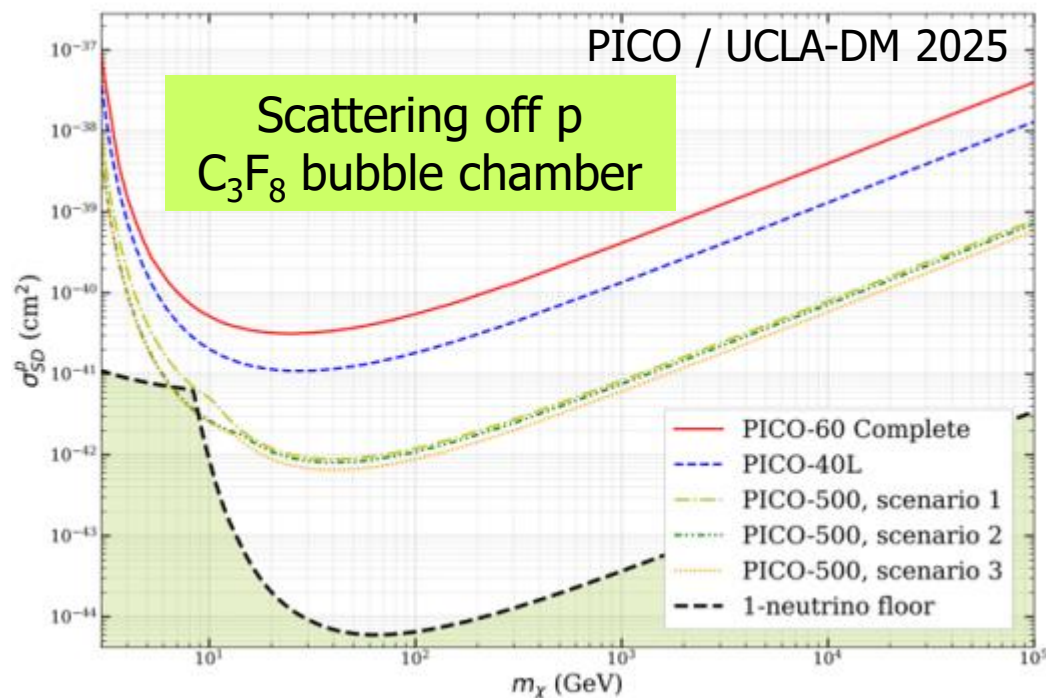
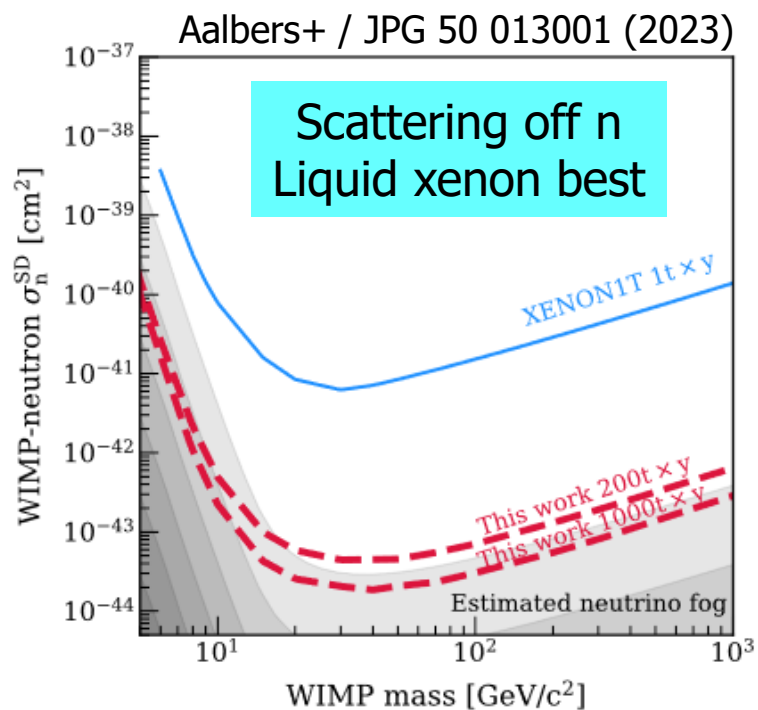

Xenon has two isotopes with unpaired neutron:  
<sup>129</sup>Xe (spin 1/2, 26%) and <sup>131</sup>Xe (spin 3/2, 21%)

## Bubble chambers

Superheated liquid

NR overcomes E barrier  
 resulting in bubble

ER not localised enough

Fluorine: unpaired proton

PICO-500 commissioning  
 expected 2026



# Status of direct detection search

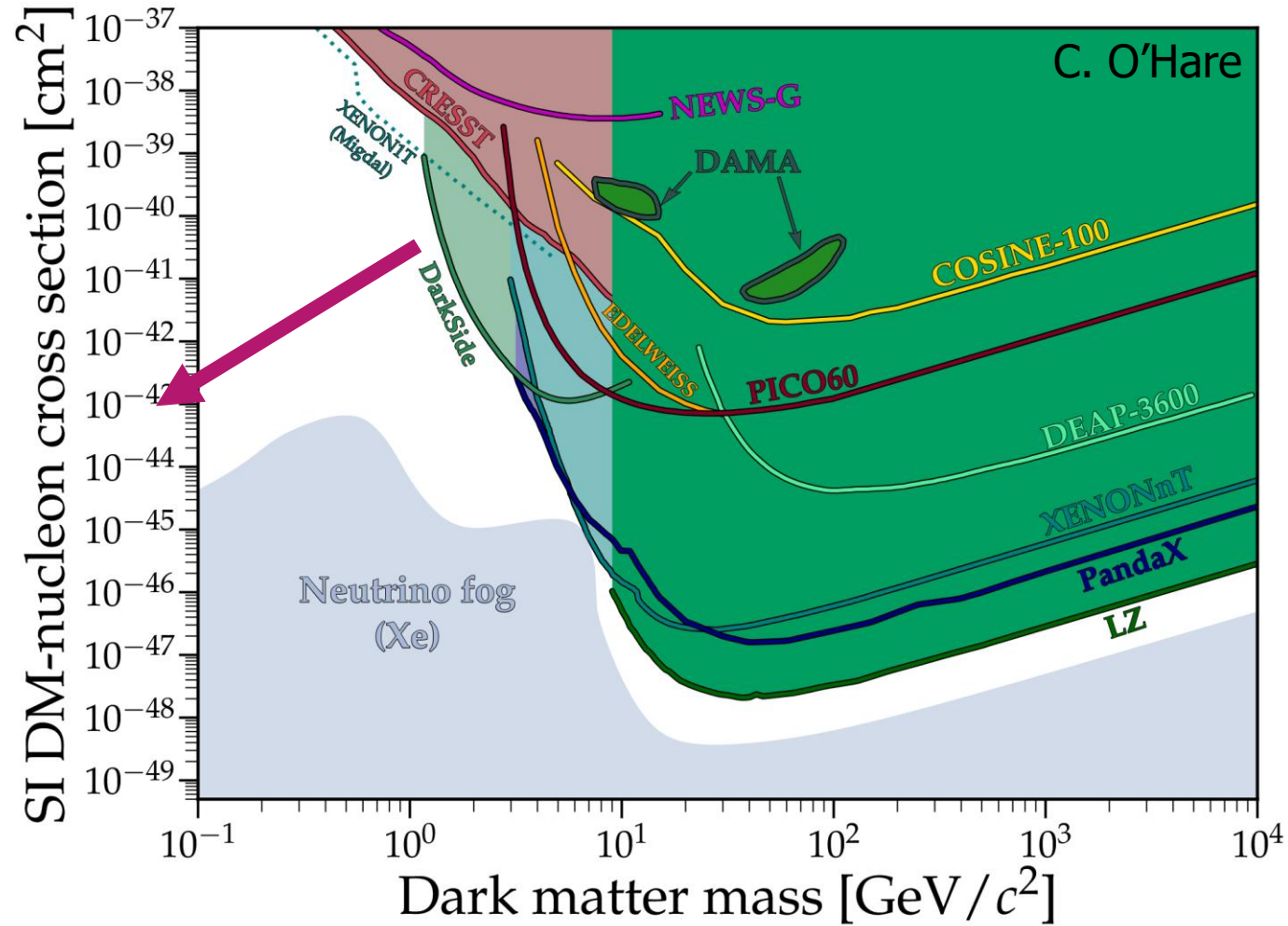

Lower thresholds  
New technologies

# Lighter dark matter

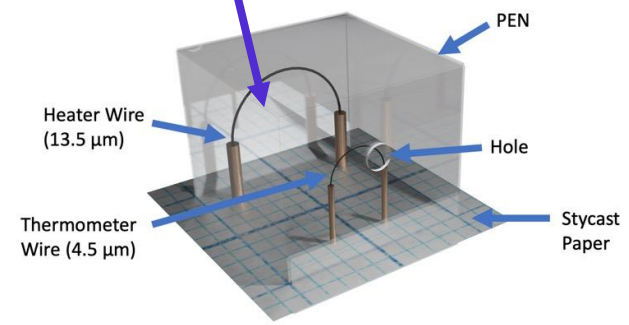
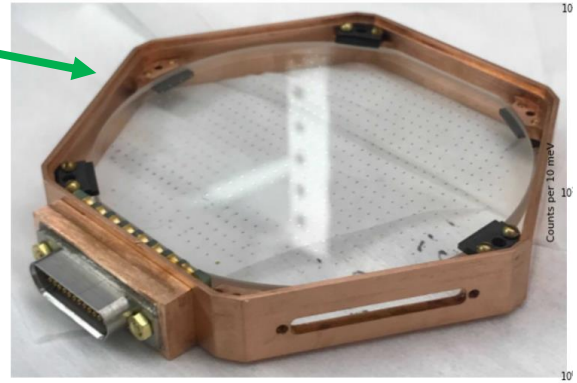
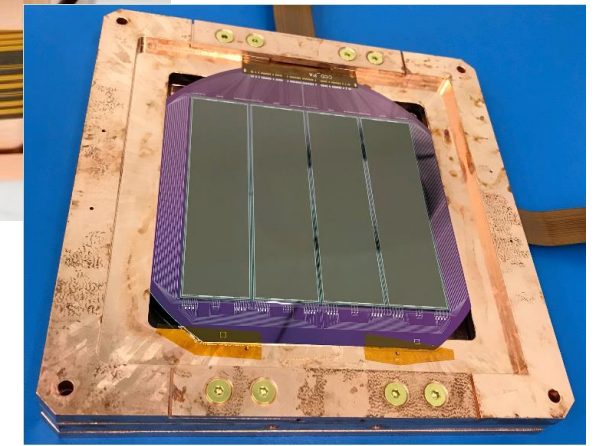
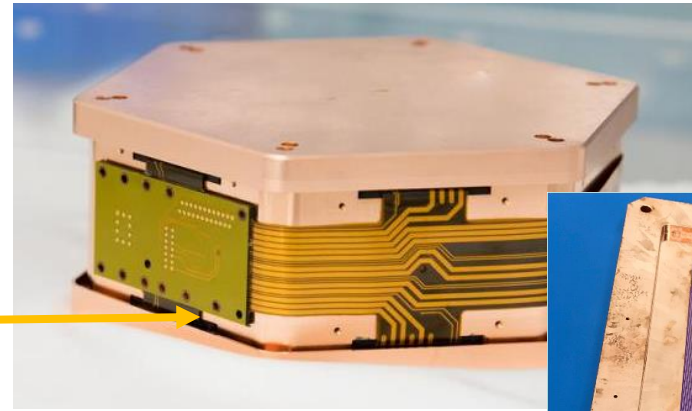
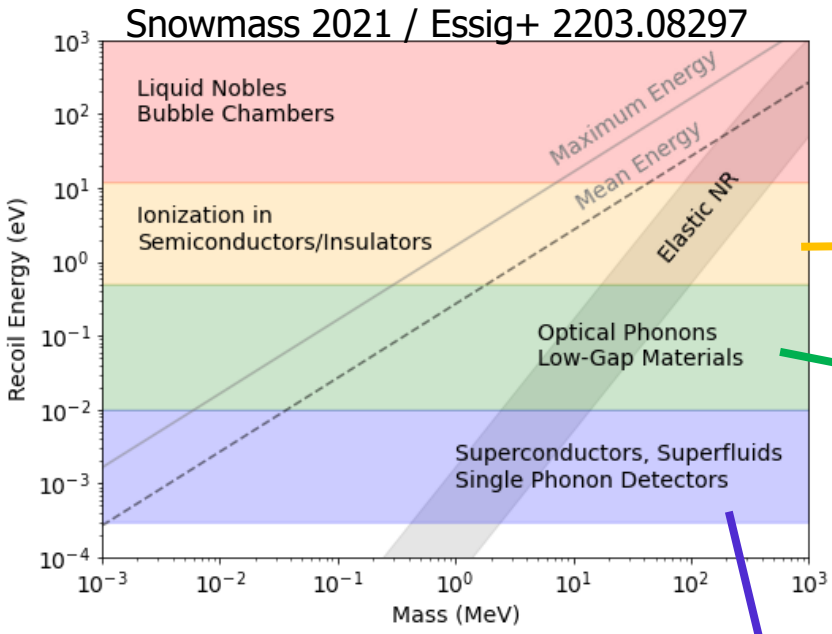

# Light dark matter searches

## Spherical proportional counters

Search in 0.05–10 GeV mass range

### NEWS-G

140 cm detector in operation at SNOLAB

Electroformed copper for future DarkSphere experiment – in Boulby?

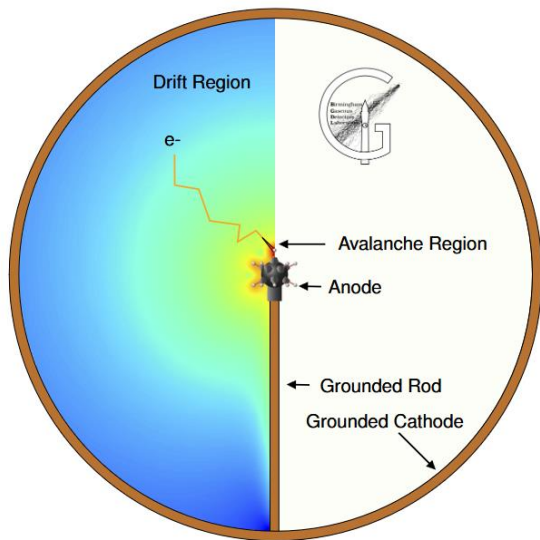

NEWS-G / PRD 108, 112006 (2023)

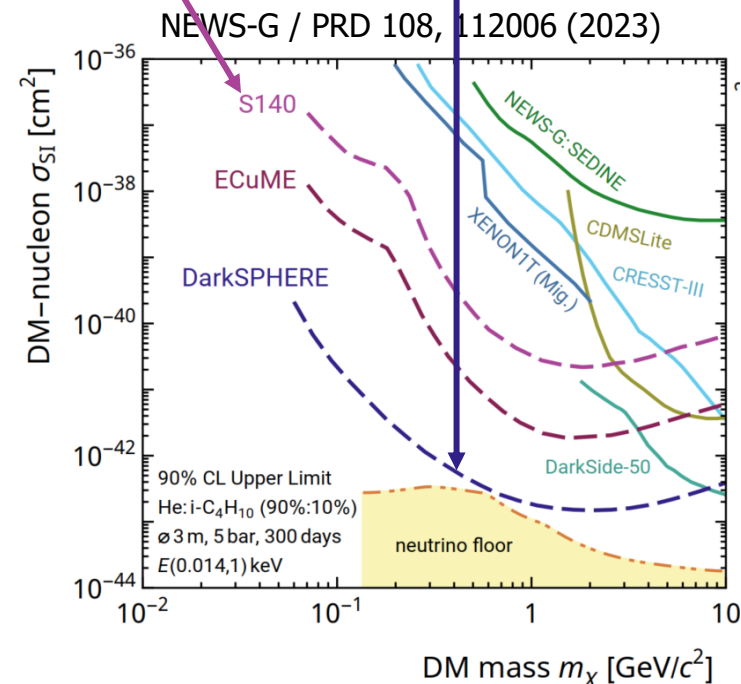
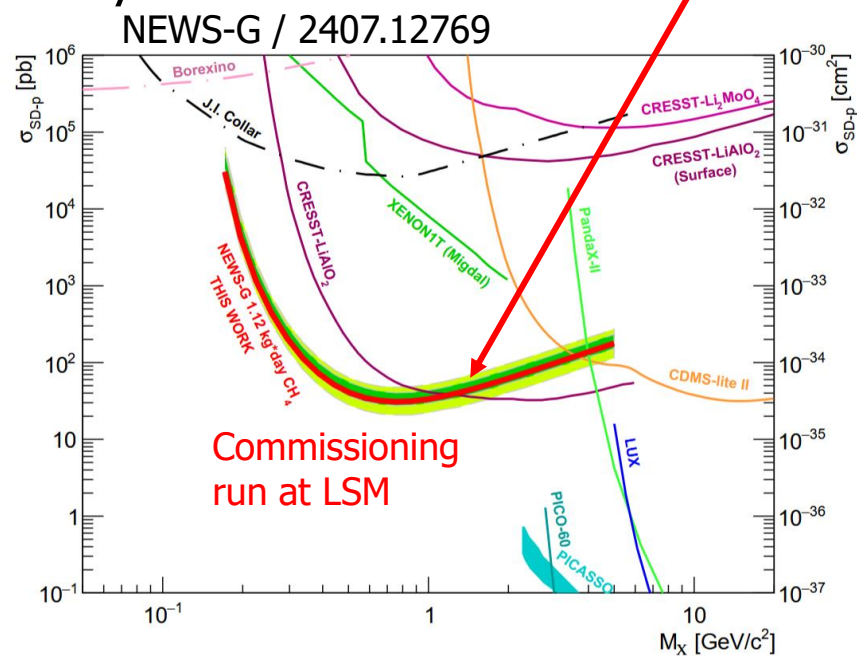
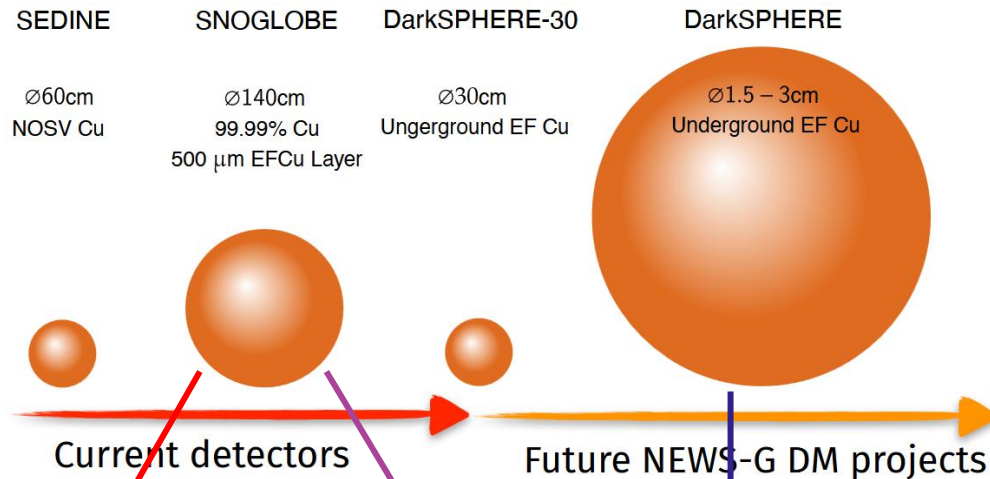

# Cryogenic solid-state detectors

Lower-mass sensitivity  $\rightarrow$  lower threshold

Phonon detection (maybe together with light/charge)

SuperCDMS: Si and Ge detectors

Mix of phonon+ionisation (discrimination) and phonon-only (lower threshold) detectors

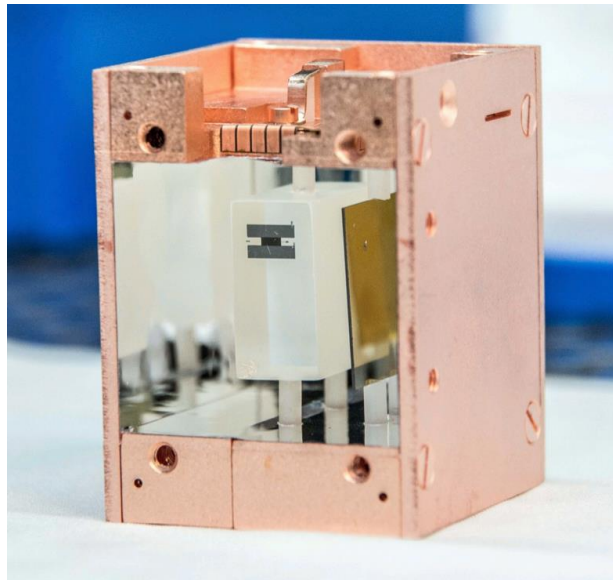
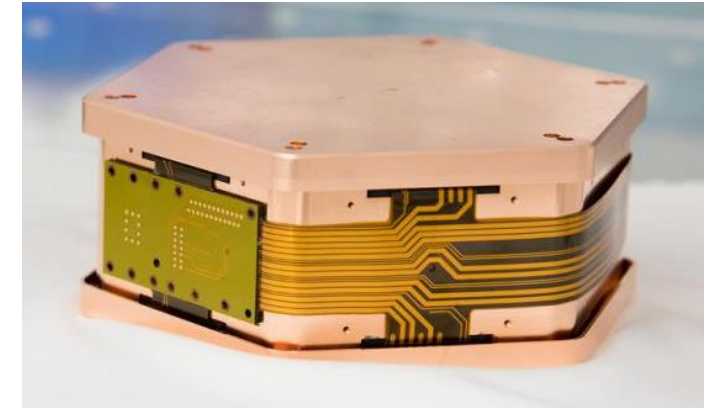

CRESST-III: CaWO4 crystals

Access to phonon and scintillation signals

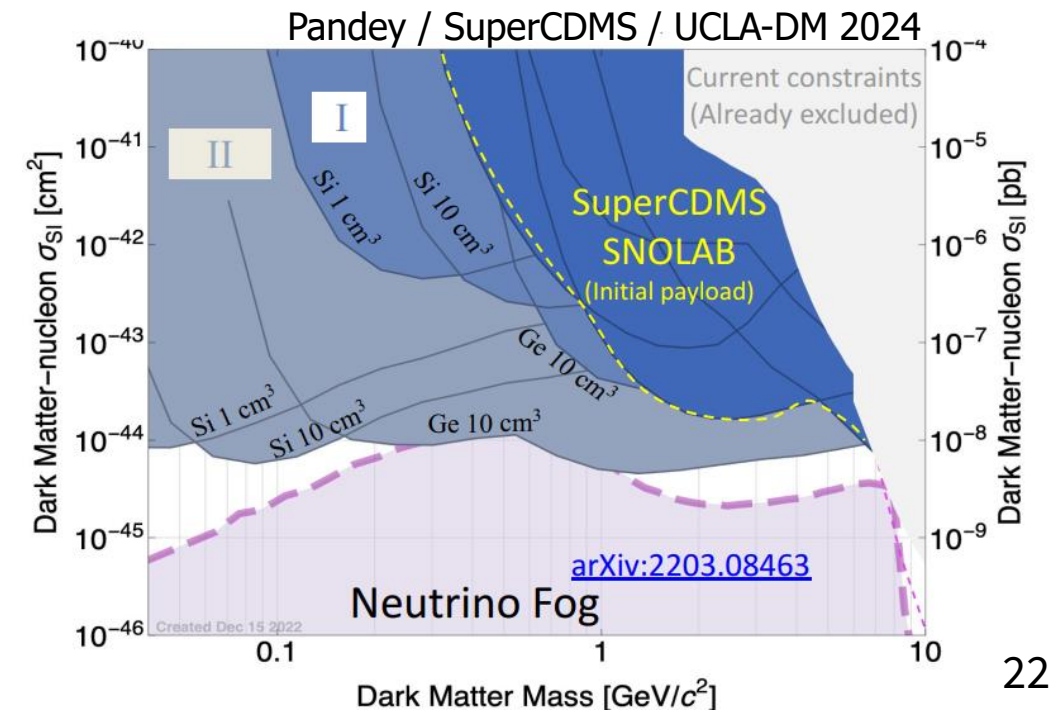

# New technologies for light dark matter search

For lighter dark matter,  
ionisation and scintillation out of reach

→ Phonon detection

Many new technologies being developed

Superfluid helium (QUEST, HeRALD, DELight)

Superconductors (TESSERACT, QROCODILE...)

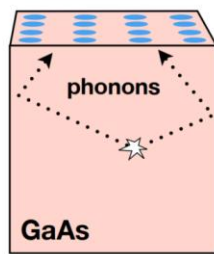
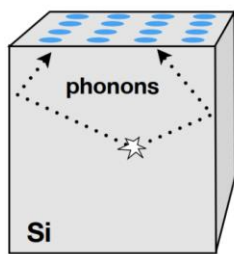
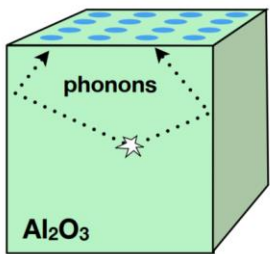

## QUEST-DMC

Superfluid  $^3\text{He}$  bolometer  
Vibrating nanowires

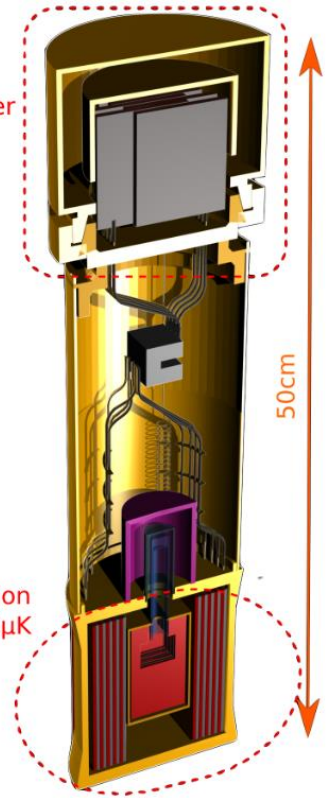
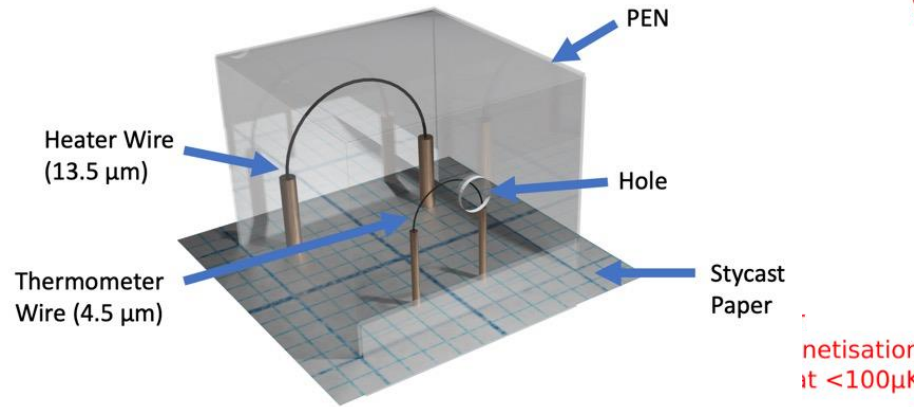

## QUEST physics potential ...

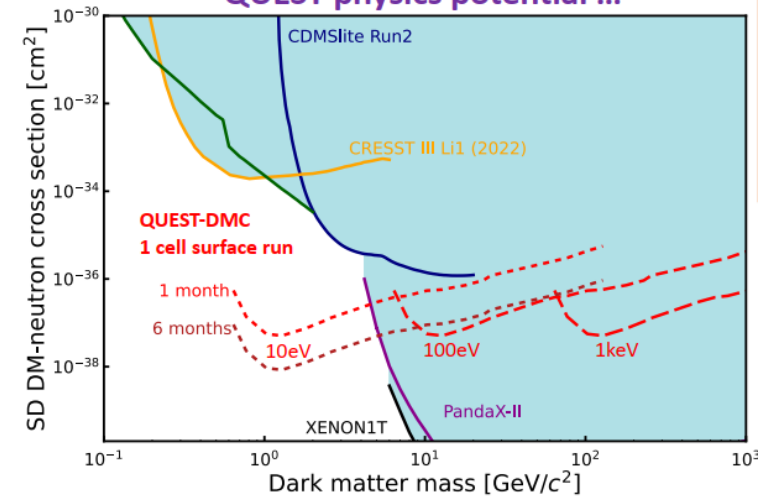

# Directional dark matter

Both solar neutrino background and galactic WIMP directional

Nuclear emulsions e.g. NEWSdm

Gas TPC can reconstruct tracks, e.g. DRIFT-II

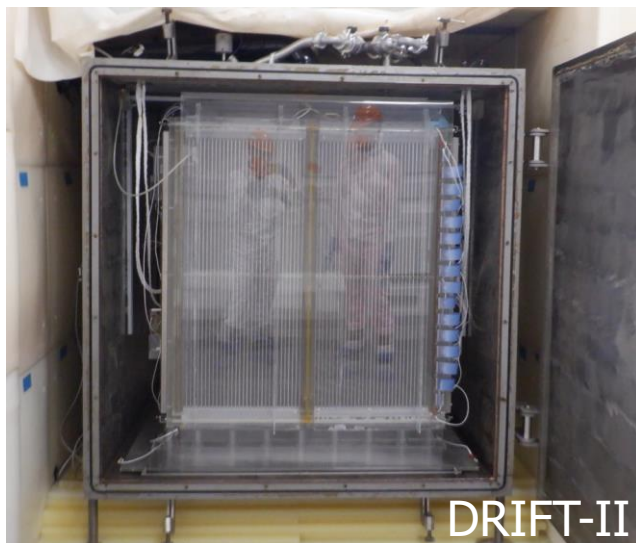

Most gas TPC effort now part of CYGNUS collaboration

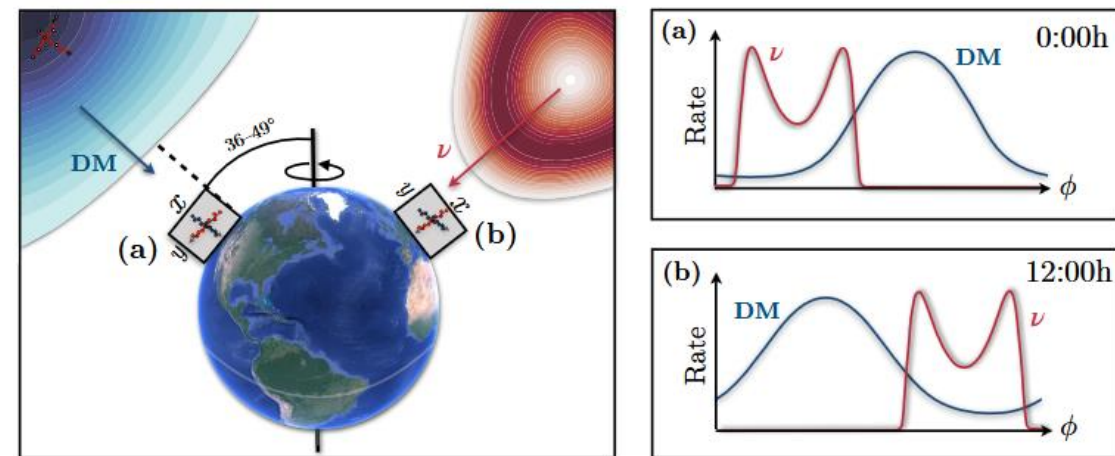
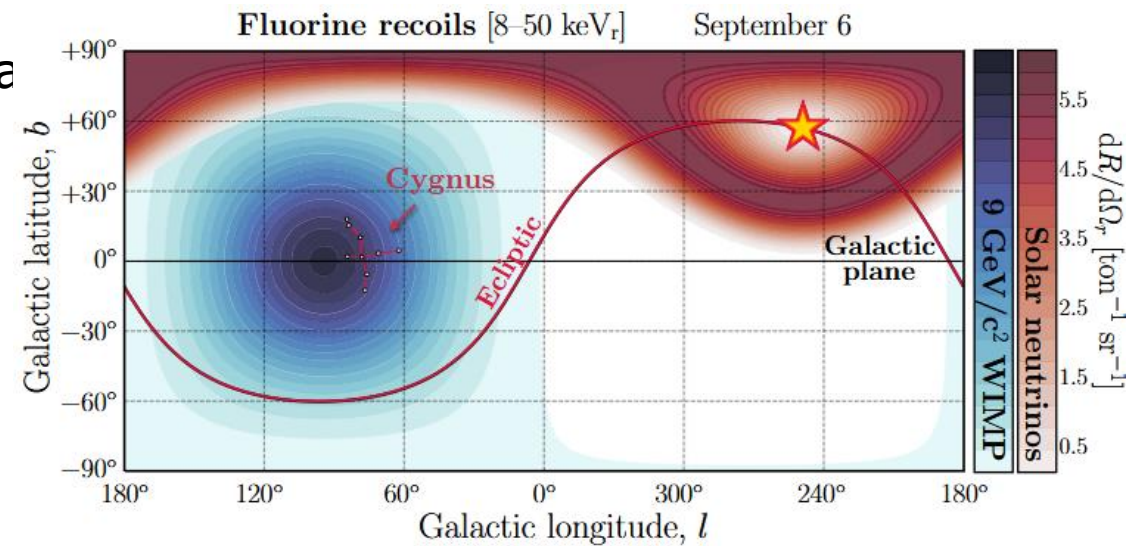

Vahsen, O'Hare, Loomba / ARNPS 71 (2021)

# There's an exciting future underground

Diverse range of current and future experiments to

**Delve deep** to low cross sections

and

**Search wide** to low dark matter masses

Dark matter is a growing field in the UK and there is potential to host experiments in Boulby

Be prepared for the unexpected!

Adam Brown

University of Sheffield

adam.m.brown@sheffield.ac.uk

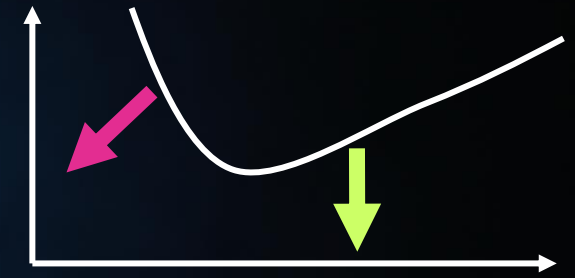

University of  
**Sheffield**