

Search for new physics in all- hadronic $t\bar{t}t\bar{t}$

Shahzad Sanjrani^{1,2}, Joel Goldstein¹,
Freya Blekman^{2,3}

¹University of Bristol

²DESY

³University of Hamburg

7 April 2025

Motivation and Background

- **Aim:** search for BSM four top quark production $t\bar{t} + X (\rightarrow t\bar{t})$
 - **Observation of $t\bar{t}t\bar{t}$** at CMS and ATLAS with leptonic event categories ([arXiv:2305.13439](https://arxiv.org/abs/2305.13439), [arXiv:2303.15061](https://arxiv.org/abs/2303.15061))
- Most event-categories **measure cross sections higher than SM prediction**

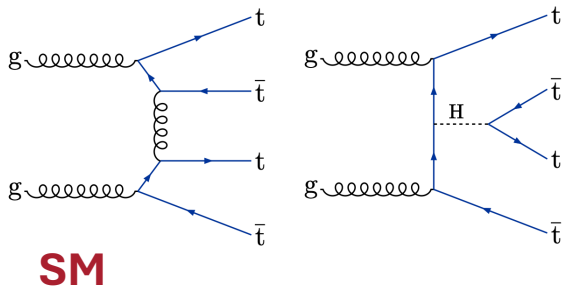

Motivation and Background

- **Aim:** search for BSM four top quark production $t\bar{t} + X \rightarrow t\bar{t}$
- **Observation of $t\bar{t}t\bar{t}$** at CMS and ATLAS with leptonic event categories ([arXiv:2305.13439](https://arxiv.org/abs/2305.13439), [arXiv:2303.15061](https://arxiv.org/abs/2303.15061))
- Most event-categories **measure cross sections higher than SM prediction**
- **BSM models modify cross sections:** e.g., type-II 2HDM, simplified dark matter, off-shell resonances...
- **Benchmark model here:** top-philic Z' resonance [arXiv:1410.6099](https://arxiv.org/abs/1410.6099)

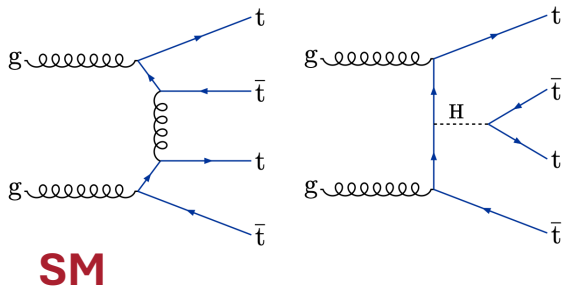

SM

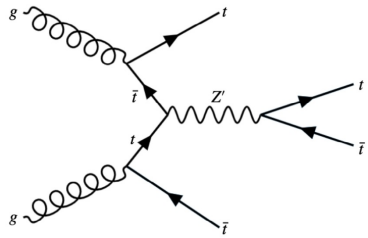

BSM

Challenge: all-hadronic final state

- Constitutes **20% of $t\bar{t}t\bar{t}$ events** & has **largest cross-section enhancement** ([arXiv:2303.03864](https://arxiv.org/abs/2303.03864))

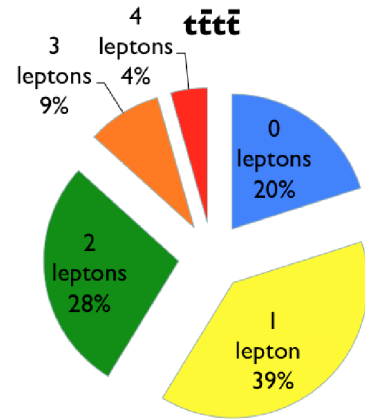

Challenge: all-hadronic final state

- Constitutes **20% of $t\bar{t}t\bar{t}$ events** & has **largest** cross-section enhancement ([arXiv:2303.03864](https://arxiv.org/abs/2303.03864))
- **Resolved regime:**
 - **Complex signature:** high jet multiplicity
 - **Large QCD multijet and $t\bar{t}$ backgrounds**

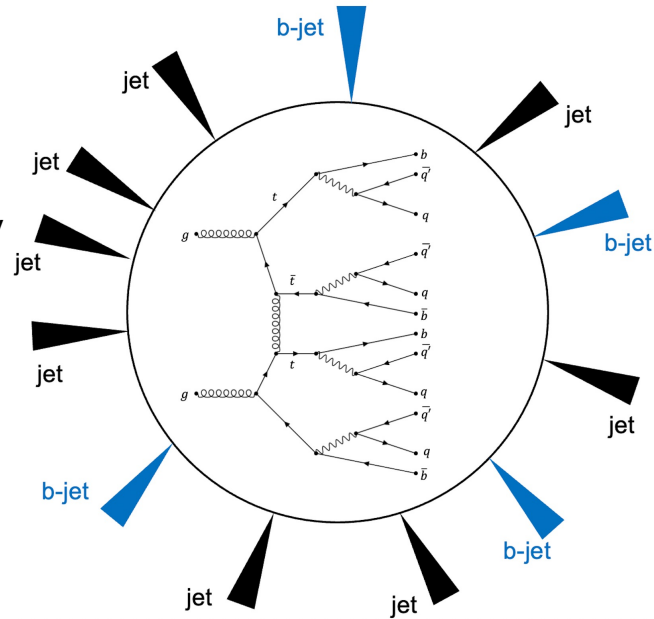

Challenge: all-hadronic final state

- Constitutes **20% of $t\bar{t}t\bar{t}$ events** & has **largest** cross-section enhancement ([arXiv:2303.03864](https://arxiv.org/abs/2303.03864))
- **Resolved regime:**
 - **Complex signature:** high jet multiplicity
 - **Large QCD multijet and $t\bar{t}$ backgrounds**
- **Tool = SPANet** ([arXiv:2106.03898](https://arxiv.org/abs/2106.03898))
 - **Symmetry Preserving Attention Network**
 - Reconstruct events with *permutation-invariant* jet-parton assignment
 - **Idea:** give all jets in the event to network → predict which daughter quarks result in which jets

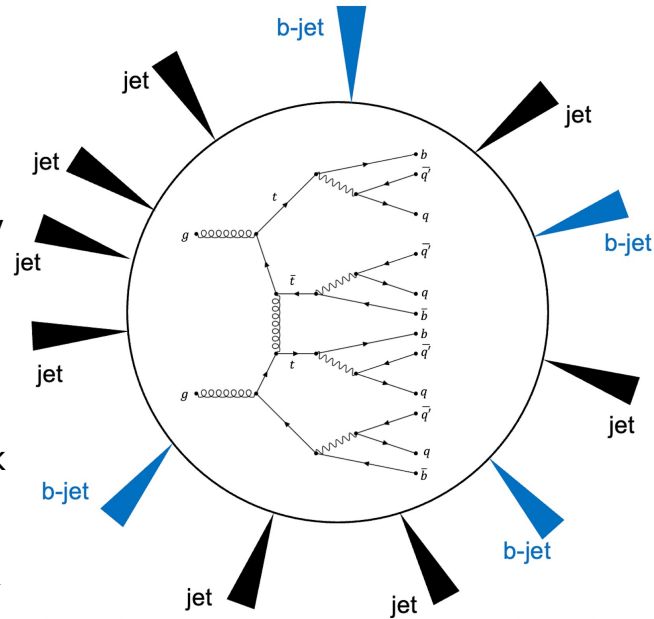

SPANet Structure ($t\bar{t}$ example)

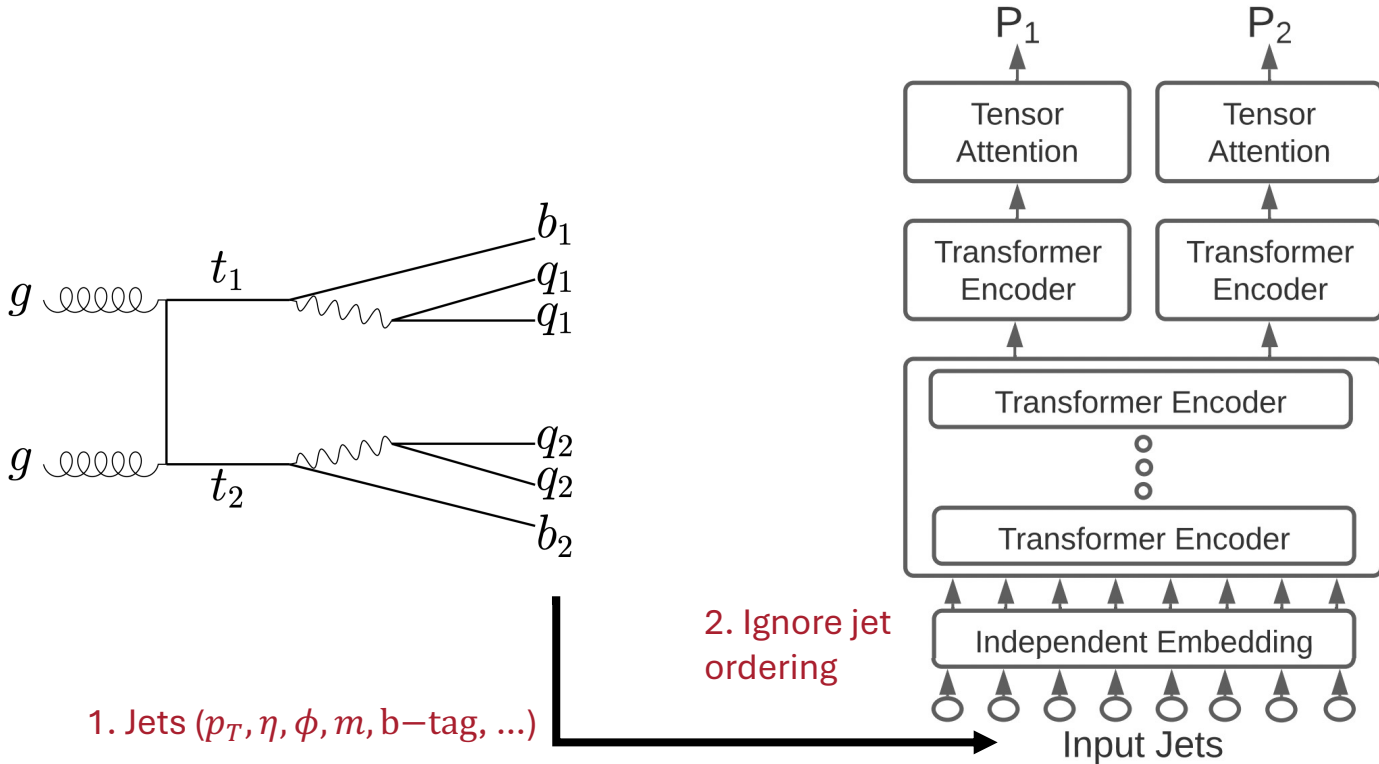

SPANet Structure ($t\bar{t}$ example)

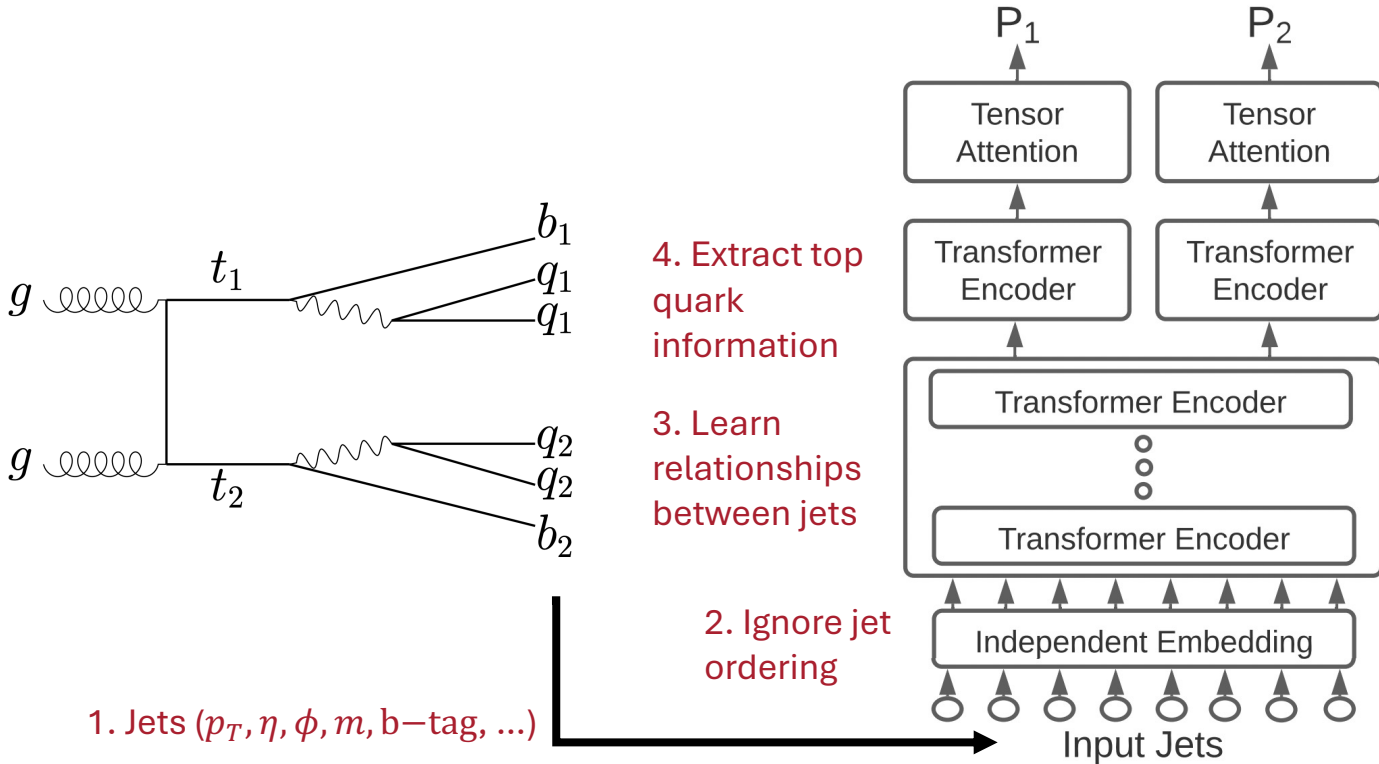

SPANet Structure ($t\bar{t}$ example)

6. Get each top's jet-assignment and probability

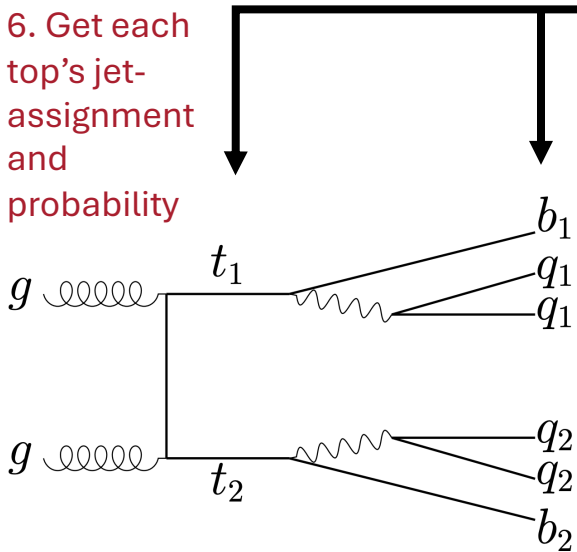

5. Solve jet-parton assignment

4. Extract top quark information

3. Learn relationships between jets

2. Ignore jet ordering

1. Jets (p_T, η, ϕ, m, b -tag, ...)

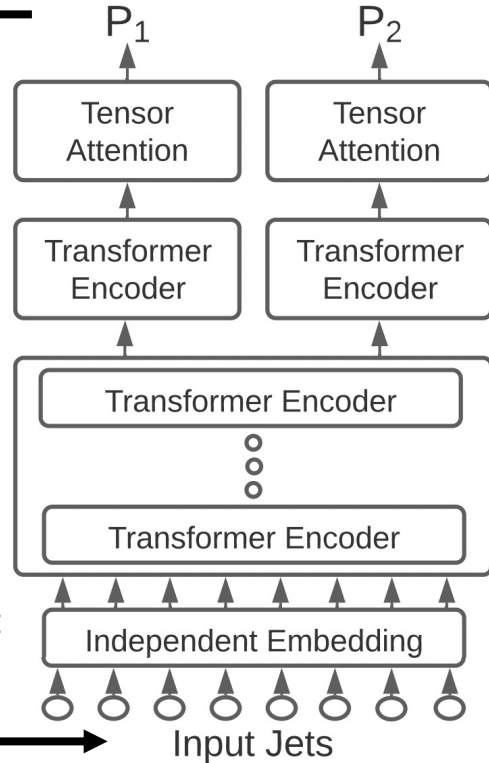

SPANet Structure ($t\bar{t}$ example)

can also add event-level regression or classification

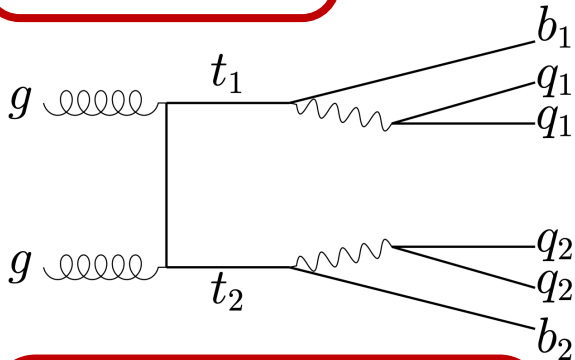

handles 'partial events':
e.g. no jet matched for b_1 ?
→ t_1 not reconstructable (masked in loss function)
→ t_2 reconstructable

5. Solve jet-parton assignment

4. Extract top quark information

3. Learn relationships between jets

2. Ignore jet ordering

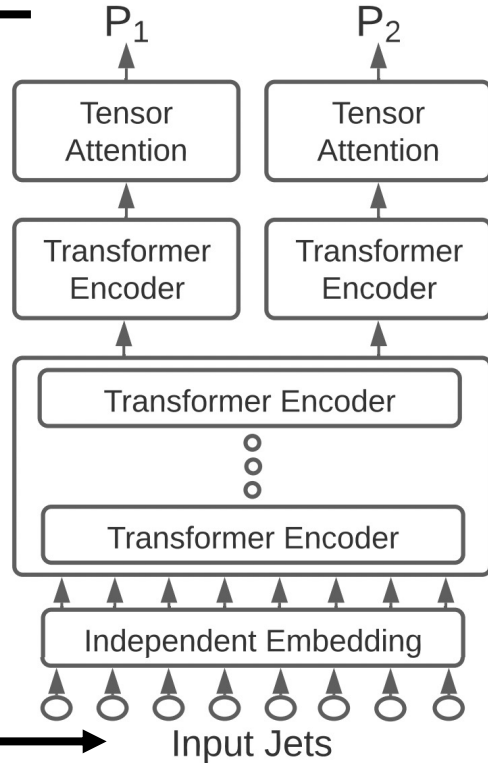

SPANet Structure ($t\bar{t}t\bar{t}$ example)

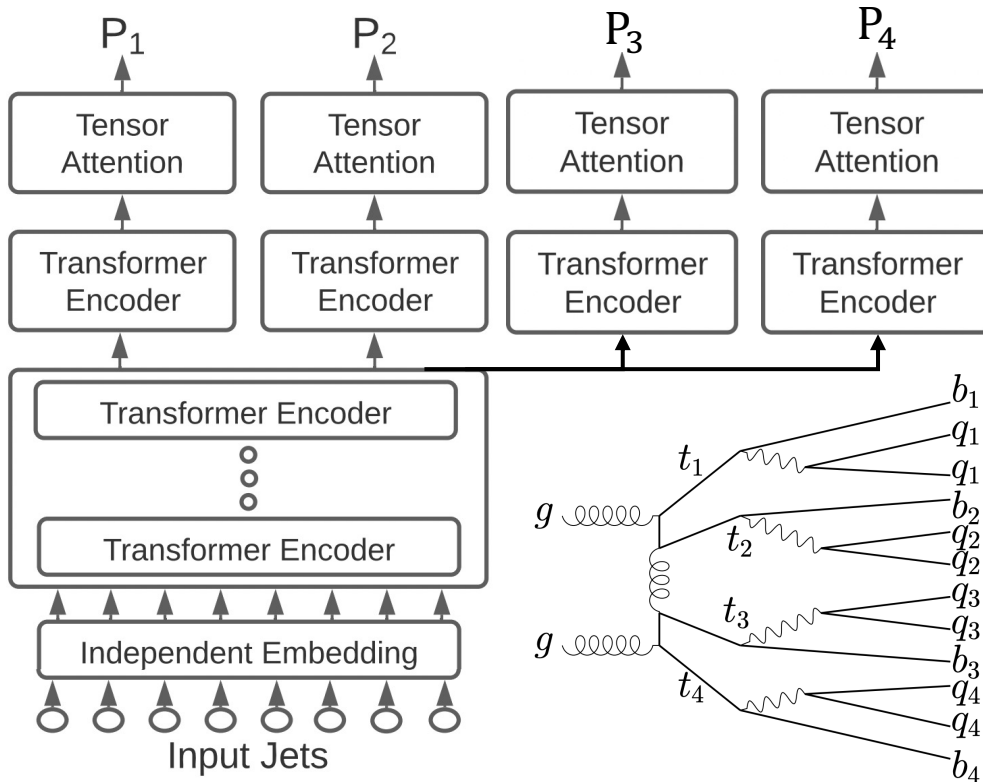

larger network for $t\bar{t}t\bar{t}$ but idea is the same

Prestudy on SM $t\bar{t}t\bar{t}$

- **Samples used:** Run II
- **Baseline selection:** 0 leptons, ≥ 9 jets, ≥ 3 b-tagged, $HT \geq 700$ GeV
- **Main backgrounds:** $t\bar{t}$; QCD multi-jet

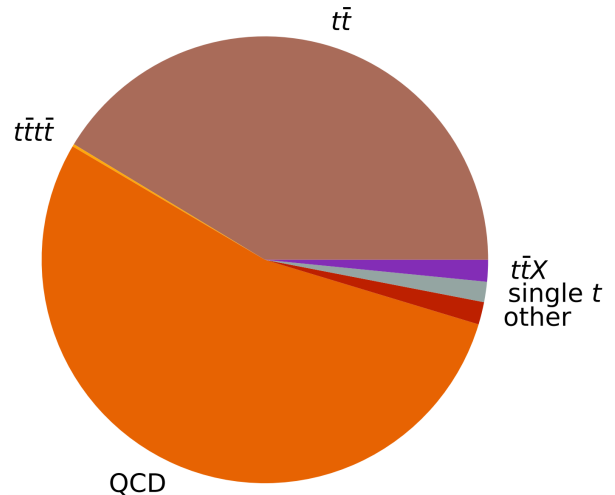

Prestudy on SM $t\bar{t}t\bar{t}$

- **Samples used:** Run II
- **Baseline selection:** 0 leptons, ≥ 9 jets, ≥ 3 b-tagged, $HT \geq 700$ GeV
- **Main backgrounds:** $t\bar{t}$; QCD multi-jet
- **Network:** ~ 2 million parameters
 - trained on (2017) SM $t\bar{t}t\bar{t}$ (~ 600 k events)
 - added classification head to predict number of **reconstructable tops** per event

predict how many hadronic tops we should be able to “see”

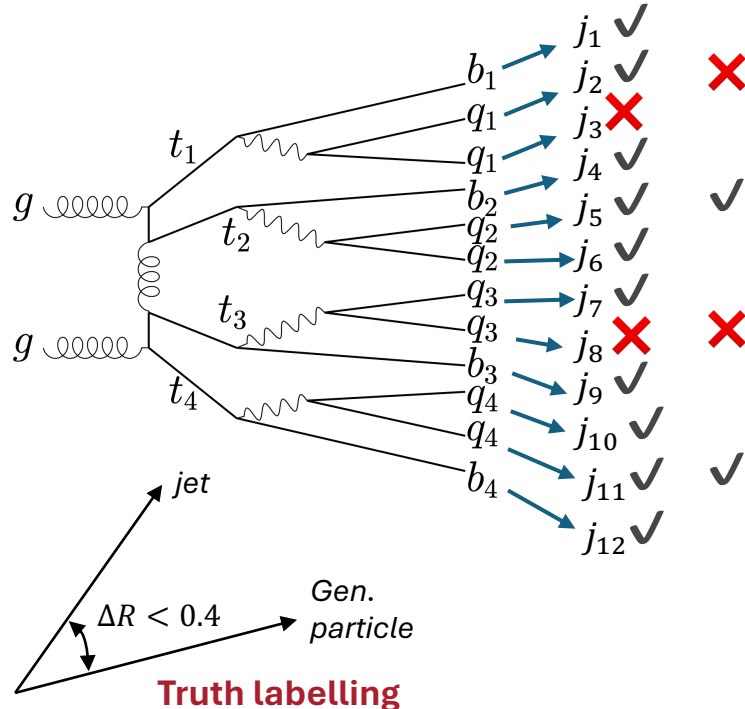

Prestudy on SM $t\bar{t}t\bar{t}$

- **Samples used:** Run II
- **Baseline selection:** 0 leptons, ≥ 9 jets, ≥ 3 b-tagged, $HT \geq 700$ GeV
- **Main backgrounds:** $t\bar{t}$; QCD multi-jet
- **Network:** ~ 2 million parameters
 - trained on (2017) SM $t\bar{t}t\bar{t}$ (~ 600 k events)
 - added classification head to predict number of **reconstructable tops** per event

bin events into
 N_j (9, ..., 15),
 N_b (3, ≥ 4),
 N_t (0, 1, 2, 3, 4)

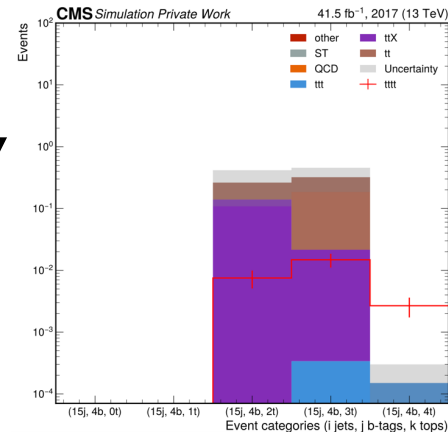
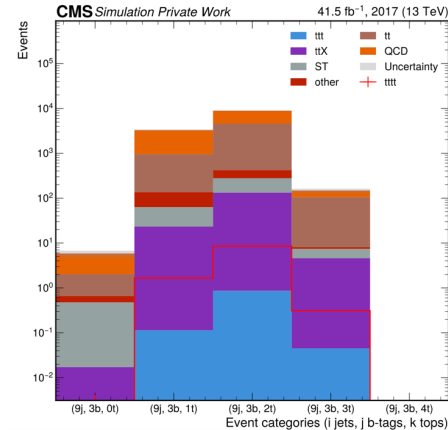

Prestudy on SM $t\bar{t}t\bar{t}$

- **Samples used:** Run II
- **Baseline selection:** 0 leptons, ≥ 9 jets, ≥ 3 b-tagged, $HT \geq 700$ GeV
- **Main backgrounds:** $t\bar{t}$; QCD multi-jet
- **Network:** ~ 2 million parameters
 - trained on (2017) SM $t\bar{t}t\bar{t}$ (~ 600 k events)
 - added classification head to predict number of **reconstructable tops** per event

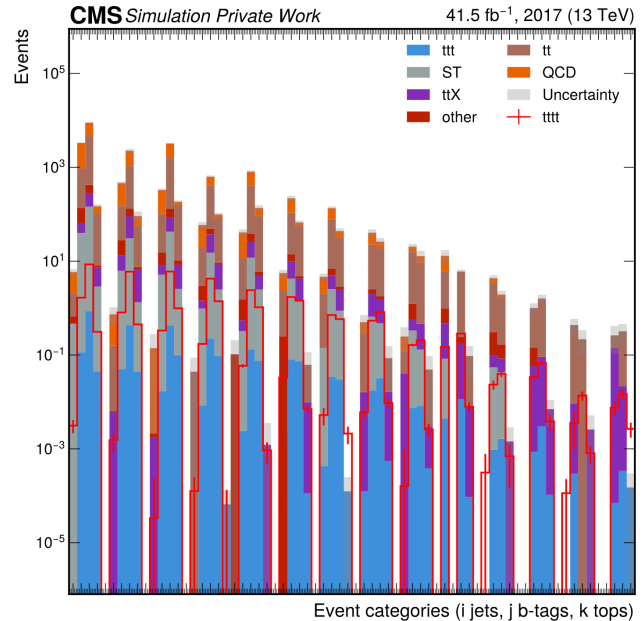

→ feed to Combine
[\[arXiv:2404.06614\]](https://arxiv.org/abs/2404.06614) for statistical
analysis

Prestudy on SM $t\bar{t}t\bar{t}$

- **Systematic uncertainties (caveats)**
 - Simplest JES and b-tagging SF splittings
 - No data-driven background estimate
 - Assign 20% cross-section uncertainty to QCD-multijet

Prestudy on SM $t\bar{t}t\bar{t}$

- **Systematic uncertainties (caveats)**

- Simplest JES and b-tagging SF splittings
- No data-driven background estimate
 - Assign 20% cross-section uncertainty to QCD-multijet

- **Cross-check for sensitivity**

- Compare against benchmark (previous all-hadronic SM four tops analysis' expected limits and significance)
- Expected limits on **signal strength** $\mu = \sigma/\sigma_{\text{SM}}$ are worse, **significance** better
- **Promising:** more simplistic implementation possible with SPA-Net

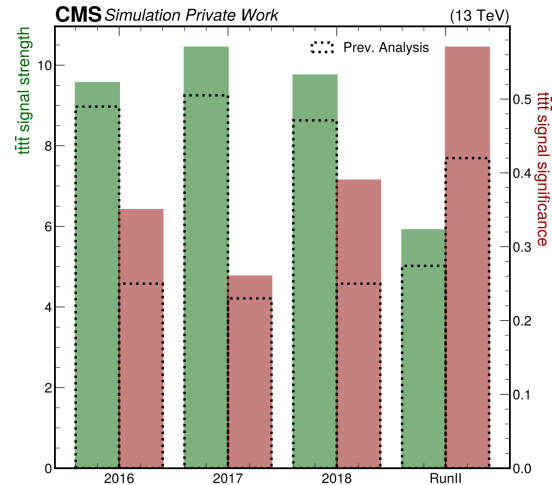

Prestudy on $Z' t\bar{t}\bar{t}$

- **Systematic uncertainties (caveats)**

- Simplest JES and b-tagging SF splittings
- No data-driven background estimate
 - Assign 20% cross-section uncertainty to QCD-multijet

- **Cross-check for sensitivity**

- Run same SM-trained network on $t\bar{t} + Z' (\rightarrow t\bar{t})$ samples
- **Promising:** see sensitivity to $m_{Z'}$, ~ 600 GeV even when trained on SM $t\bar{t}\bar{t}$

- **Next steps:** squeeze object/event selection for more Z' events

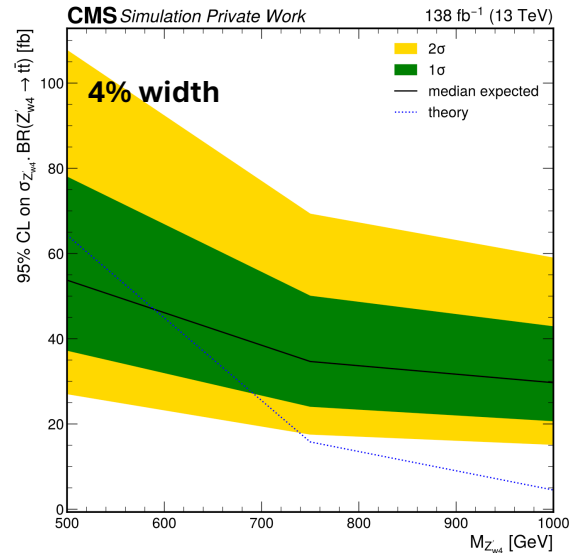

Lowering the jet p_T threshold

- Does matching efficiency improve?

- Match:** $\Delta R < 0.4$ of parton with jet

- $$\epsilon = \frac{N_{match}}{N_{match} + N_{not\ matched}}$$

- > 20% increase in efficiency when we lower threshold $p_T \geq 35 \rightarrow p_T \geq 20$ GeV

- Expected:** low p_T match more often if given low p_T jets

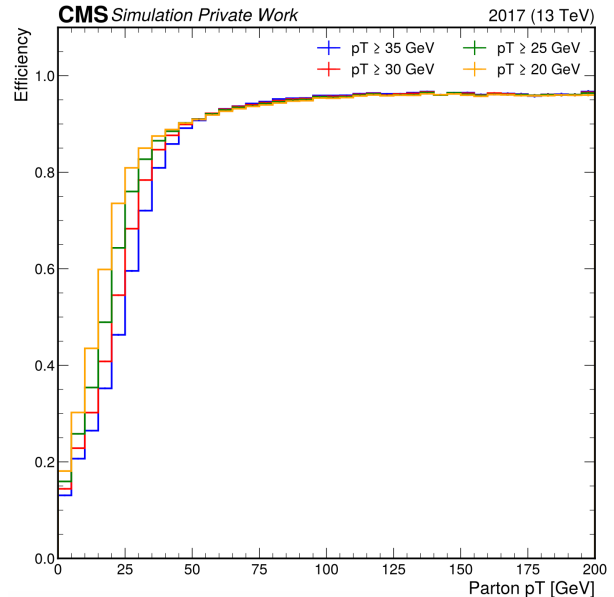

Lowering the jet p_T threshold

- **Does matching efficiency improve?**

- **Match:** $\Delta R < 0.4$ of parton with jet
- $\epsilon = \frac{N_{match}}{N_{match} + N_{not\ matched}}$
- > 20% increase in efficiency when we lower threshold $p_T \geq 35 \rightarrow p_T \geq 20$ GeV
- **Expected:** low p_T match more often if given low p_T jets

- **Get more (hadronic) tops to train on?**

- Reconstructable tops: where each daughter quark matched to a jet
- $\epsilon(n) = \frac{N(n\ reco.\ tops | all-hadronic\ 4t)}{N(all-hadronic\ 4t)}$
- 10x increase for all (four) tops being reconstructable
- **SPANet: more tops \rightarrow better training**

<i>n reco. tops</i>	<i>Jet $p_T \geq 35$ GeV</i>	<i>Jet $p_T \geq 20$ GeV</i>
0t	16.19%	6.82%
1t	47.18%	31.58%
2t	30.83%	40.61%
3t	5.54%	18.39%
4t	0.26% $\xrightarrow{10x}$	2.60%

Lowering the jet p_T threshold

- **Get more events?**

- Baseline selection: ≥ 9 jets, ≥ 3 b-tags, $HT > 700$ GeV, 0 leptons
- **Trade-off:** more background \rightarrow better discrimination?

	$Jet p_T \geq 35$ GeV	$Jet p_T \geq 20$ GeV
Signal* (weighted)	~ 190	~ 330
Signal* (unweighted)	$\sim 60,000$	$\sim 110,000$
Total background* (weighted)	$\sim 11,000$	$\sim 200,000$
Total background* (unweighted)	$\sim 400,000$	$\sim 1,900,000$

*signal numbers similar across samples

*excluding SM $t\bar{t}t\bar{t}$ background

Lowering the jet p_T threshold

- **Get more events?**

- Baseline selection: ≥ 9 jets, ≥ 3 b-tags, HT > 700 GeV, 0 leptons
- **Trade-off:** more background \rightarrow better discrimination?

- **Conclusion?**

- Gen studies show going to 20 GeV is worth it
- **Current work:**
 - Improving event selection to handle triggers used (designed for $p_T \geq 30 - 40$ GeV)

	$Jet p_T \geq 35$ GeV	$Jet p_T \geq 20$ GeV
Signal* (weighted)	~190	~330
Signal* (unweighted)	~60,000	~110,000
Total background* (weighted)	~11,000	~200,000
Total background* (unweighted)	~400,000	~1,900,000

*signal numbers similar across samples

*excluding SM $t\bar{t}t\bar{t}$ background

Summary

- **Physics analysis:** on a Z' search in $t\bar{t}t\bar{t}$ in the all-hadronic channel
- **SPANet:** solves jet-parton assignment for event reconstruction in single NN pass
- Obtained **initial results on Run II** using a **single NN model:**
 - Trained using 2017 SM $t\bar{t}t\bar{t}$
 - Simple event categorisation using predicted n. reconstructable tops and jet multiplicities
 - Promising sensitivity for low Z' masses
 - **Caveats:** no data-driven background & simple treatment of jet unc.
- Gen-studies show promise for **lowering jet p_T threshold**,
- **Current work:** revising event selection for viable trigger scale factors

THANK YOU FOR LISTENING

Backup

SPA-Net Structure

- **SPA-Net = Symmetry Preserving Attention Network**
 - **Input:** unsorted list of four vectors of all jets in each event (can be variable size)
 - **Independent Embedding:** produces latent space representation of the inputs where ordering of jets doesn't matter
 - **Transformer Encoder (central stack):** learn contextual relationships between jets
 - **Transformer Encoder (branches):** learn contextual relationships between jets for each resonance particle (each branch) separately (e.g., t and \bar{t} in $t\bar{t}$)
 - **Tensor Attention:** solves jet-parton assignment separately for each resonance particle to test all valid permutations in single pass using **Symmetric Tensor Attention**
 - Calculate dot-product attention with symmetry in mind (e.g., $q \leftrightarrow q'$)
 - **Output:** probability of assignments as a rank- k_p tensor $P_p \in \mathbb{R}^{N \times N \times \dots \times N}$ for each resonance particle p where k_p is the number of partons associated with each resonance particle, and N is the number of jets
- **Combined Symmetric Loss:** cross-entropy loss calculated during training with symmetry between resonance particles in mind (e.g., $t \leftrightarrow \bar{t}$)

SPA-Net architecture for all-hadronic $t\bar{t}$

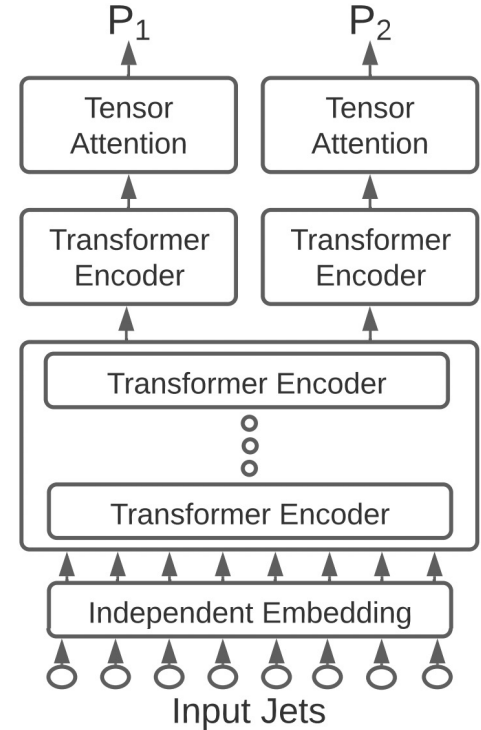

Extended SPA-Net Structure

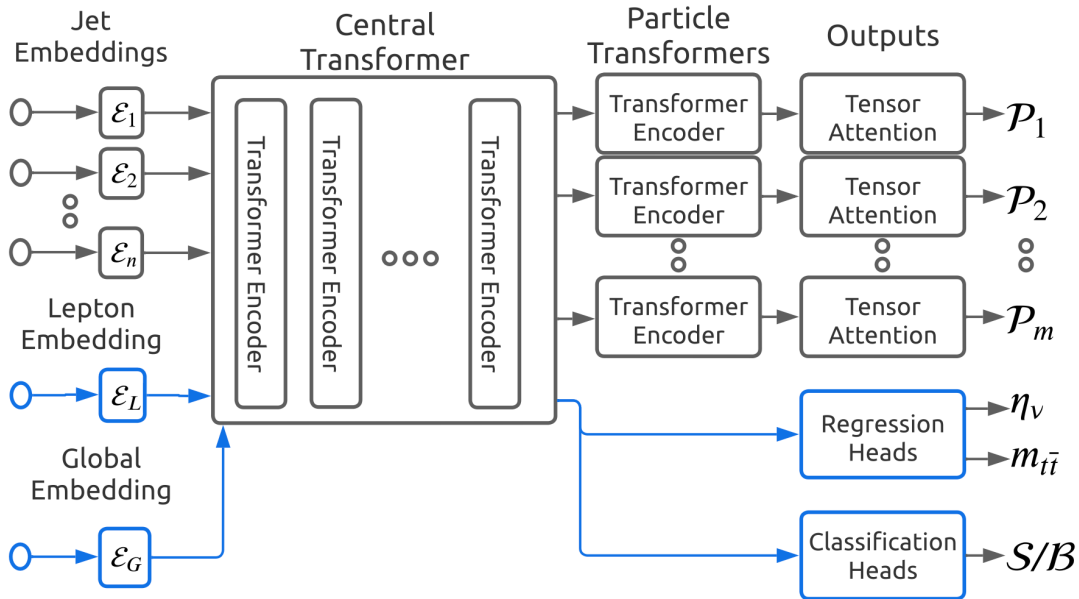

Source

$$\mathcal{L} = \alpha_{\text{reco}} \mathcal{L}_{\text{reconstruction}} + \alpha_{\text{det}} \mathcal{L}_{\text{detection}} + \alpha_{\text{clas}} \mathcal{L}_{\text{classification}} + \alpha_{\text{regr}} \mathcal{L}_{\text{regression}}$$

complete loss equation

Systematics (for the SM $t\bar{t}t\bar{t}$ prestudy)

Systematic	Type	Processes	Correlations	$t\bar{t}t\bar{t}$ uncertainty (%)	Background uncertainty (%)
Trigger SF	Shape	All	processes	1-2	1-2
B-tag SF	Shape	All	processes	3-7	8-13
B-tag SF (light)	Shape	All	processes	< 1	4-7
Pileup	Shape	All	processes	< 1	0-2
JER	Shape	All	processes	< 1	0-10
JES	Shape	All	processes	5-7	9-16
UncMET	Shape	All	processes	< 1	0-2
L1 prefireing	Shape	All (2016, 2017)	processes	0-2	0-2
μ_F	Shape	All	years	< 1	3-4
μ_R	Shape	All	years	1-3	3
ISR	Shape	All	processes + years	1-3	4-8
FSR	Shape	All	processes + years	1-4	9-15
PDF	Shape	All	processes + years	4-6	3-6
PDF α_S	Shape	All	processes + years	5-6	5
Luminosity	lnN	All	processes + years	0-2.5	0-2.5
cross section	lnN	$t\bar{t}$, QCD, $t\bar{t}X$	years	-	4-26

Key:

- Most sensitive to
- Need to revise
 - Further splitting for JER, JES, and b-tagging SFs
 - Data driven background estimation for QCD

Triggers used

Year	HLT path	Act. lumi (fb^{-1})	Eff. lumi (fb^{-1})
2016	HLT_PFHT400_SixJet30_DoubleBTagCSV_p056	35.9	35.9
	HLT_PFHT450_SixJet40_BTagCSV_p056	35.9	35.9
2017	HLT_PFHT380_SixJet32_DoubleBTagCSV_p075	4.8	4.8
	HLT_PFHT430_SixJet40_BTagCSV_p080	4.8	4.8
	HLT_PFHT380_SixPFJet32_DoublePFBTagCSV_2p2	36.7	36.7
	HLT_PFHT430_SixPFJet40_PFBTagCSV_1p5*	36.7	32.1
2018	HLT_PFHT380_SixPFJet32_DoublePFBTagDeepCSV_2p2	17.7	17.7
	HLT_PFHT430_SixPFJet40_PFBTagDeepCSV_1p5	12.4	12.4
	HLT_PFHT400_SixPFJet32_DoublePFBTagDeepCSV_2p94	42.1	42.1
	HLT_PFHT450_SixPFJet36_PFBTagDeepCSV_1p59	42.1	42.1

$t\bar{t} + Z'(\rightarrow t\bar{t})$ cross-sections (fb-l)

Mass [GeV]	Width 4%	Width 10%	Width 20%	Width 50%
500	75.6	75.6	75.6	75.6
750	16.4	16.4	16.4	16.4
1000	4.69	4.69	4.69	4.69
1250	1.52	1.52	1.52	1.52
1500	0.54	0.54	0.54	0.54
1750	0.207	0.207	0.207	0.207
2000	0.085	0.085	0.085	0.085
2500	0.0161	0.0161	0.0161	0.0161
3000	0.00335	0.00335	0.00335	0.00335
4000	0.00016	0.00016	0.00016	0.00016