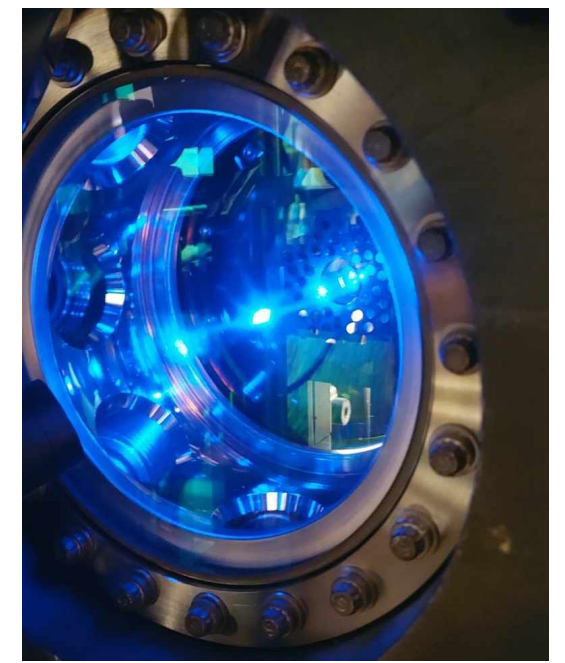
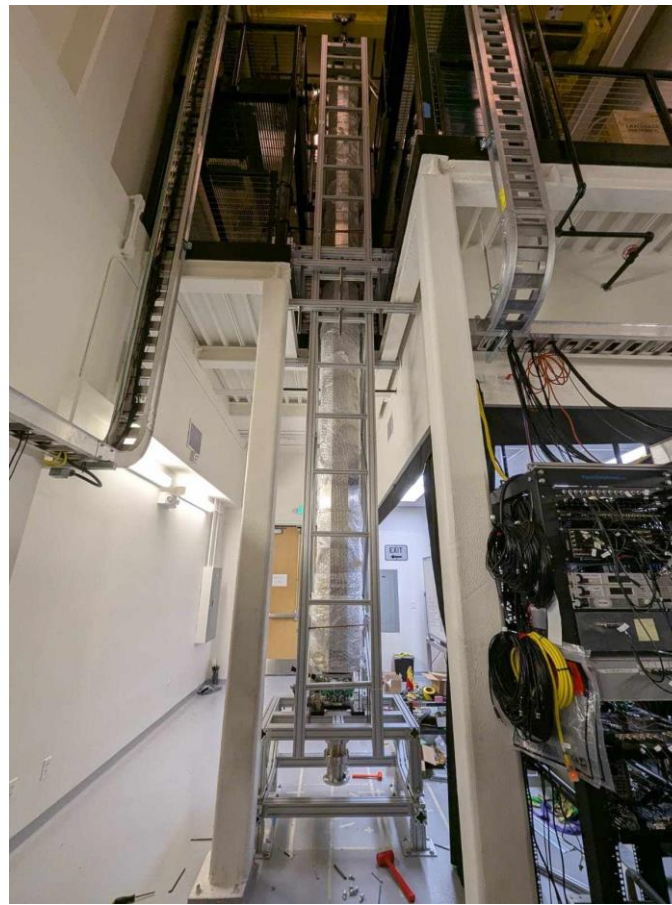


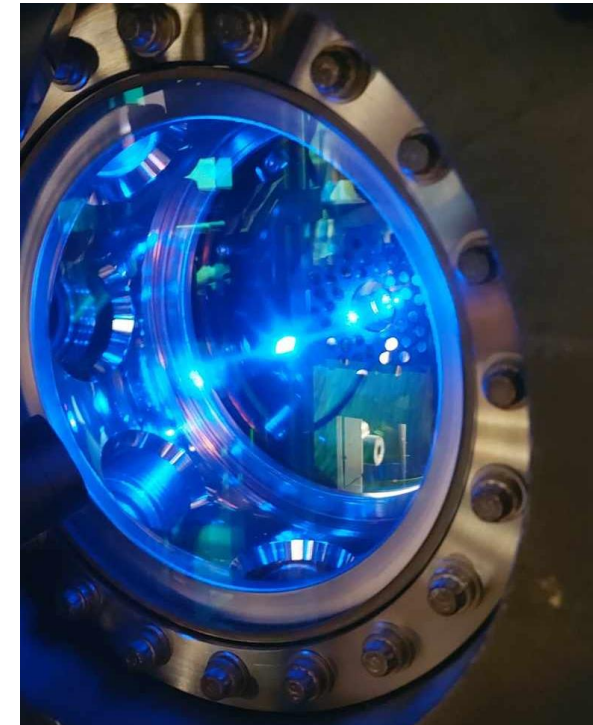
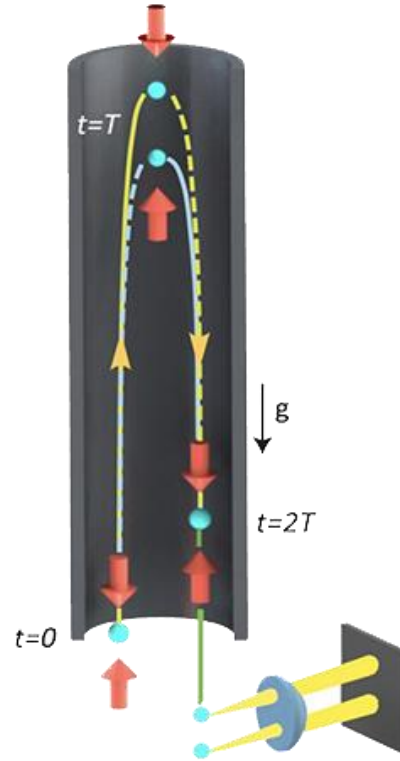
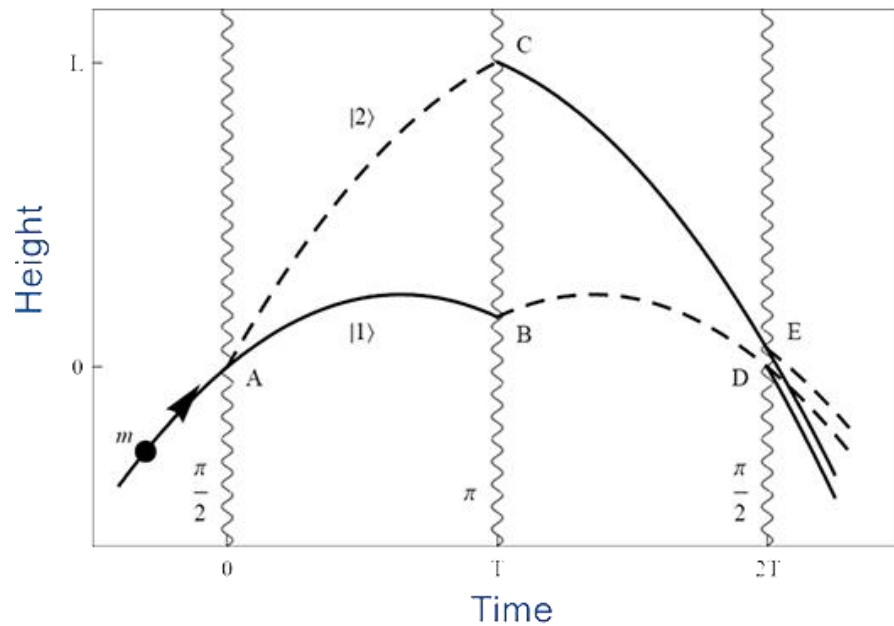
# Rotation Compensation System for the MAGIS-100 Prototype

*Henry Throssell  
IOP HEPP and APP 2025 Meeting  
h.throssell@Liverpool.ac.uk*



*Top: The MAGIS-100 prototype  
Top Right: A magneto optical trap of  
Sr-88 atoms  
Bottom Right: A hologram of a cat  
made with the spatial light  
modulator used for atom trapping*

# Light Pulse Atom Interferometry

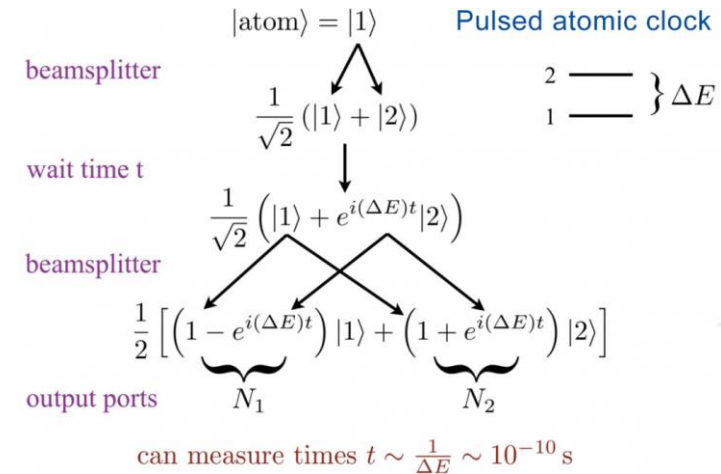
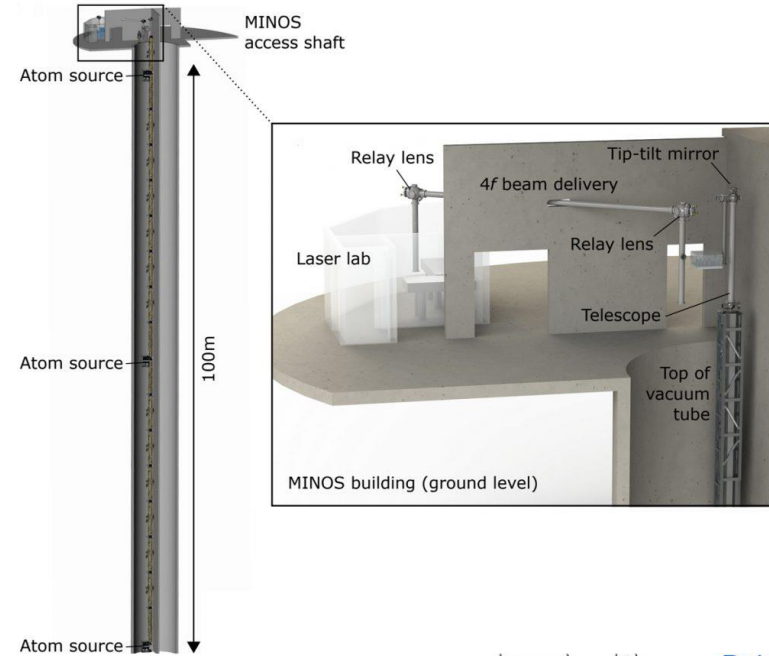


- Free falling ultracold atoms ( $\mu\text{K}$ - $\text{pK}$ ) as quantum sensors
- Laser pulses open and close arms of a Mach-Zehnder matter wave interferometer
- Laser interactions transfer momentum to excited state population
- Additional laser pulses (LMT) increase the space time area of the interferometer and enhance sensitivity

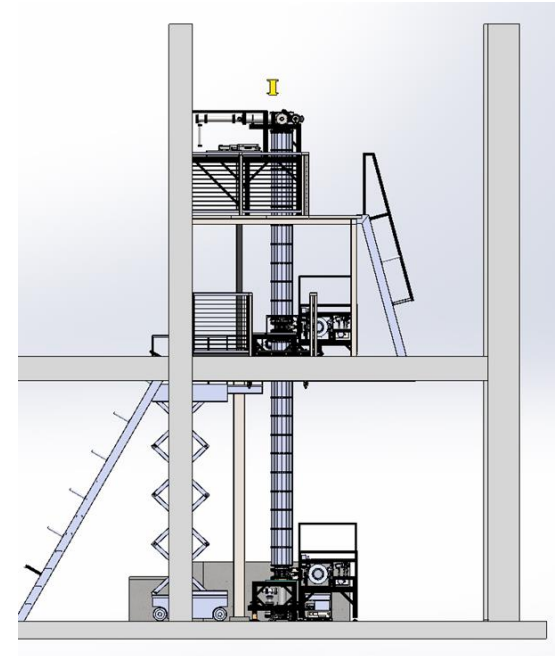
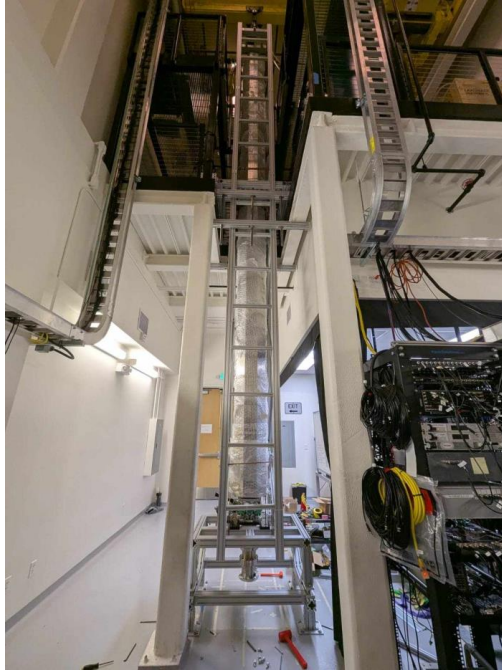


# MAGIS-100 - Atom Interferometry for Gravitational Wave and Dark Matter Searches

- The MAGIS experiment uses ultracold Sr atoms as a sensor for:
  - Mid-band gravitational waves (10mHZ – 10 Hz)
  - Ultralight dark matter ( $10^{-3}$  -  $10^{-22}$  eV)
- 100 m baseline device under construction at Fermilab, eventual goal of 1000 m and space-based experiments
- Simultaneous atom interferometers over a long baseline measure the strain in spacetime caused by GWs
- Phase shift recorded by each interferometer depends on the time spent in the excited state, which is directly tied to the light travel time across the baseline
- DM induced oscillations of fundamental constants ( $\alpha$ ,  $m_e$ ) shift atomic energy levels



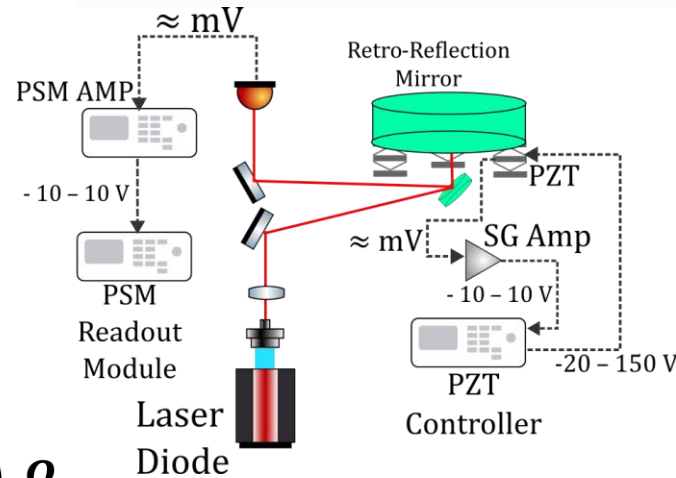
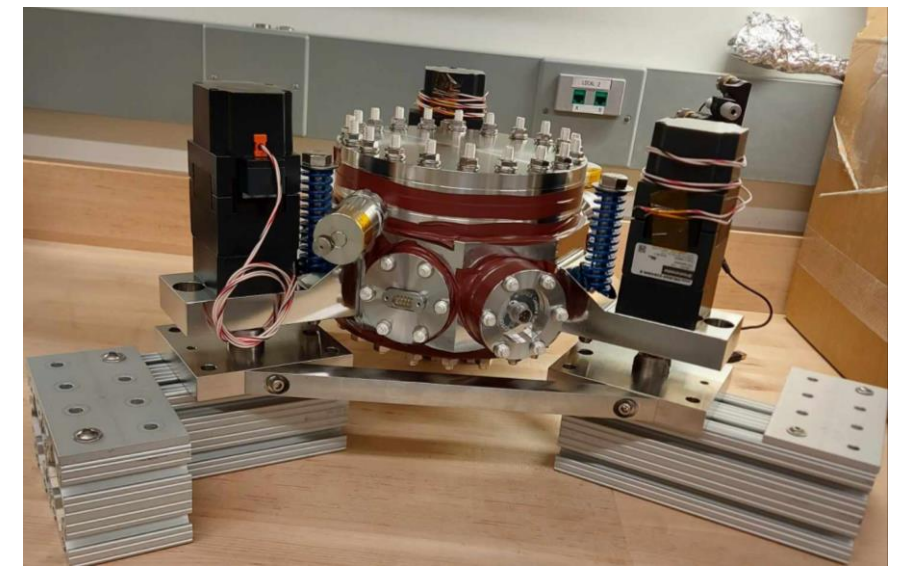
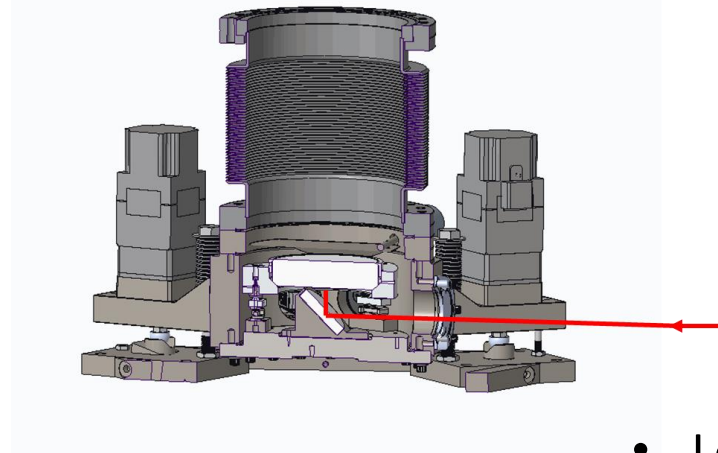
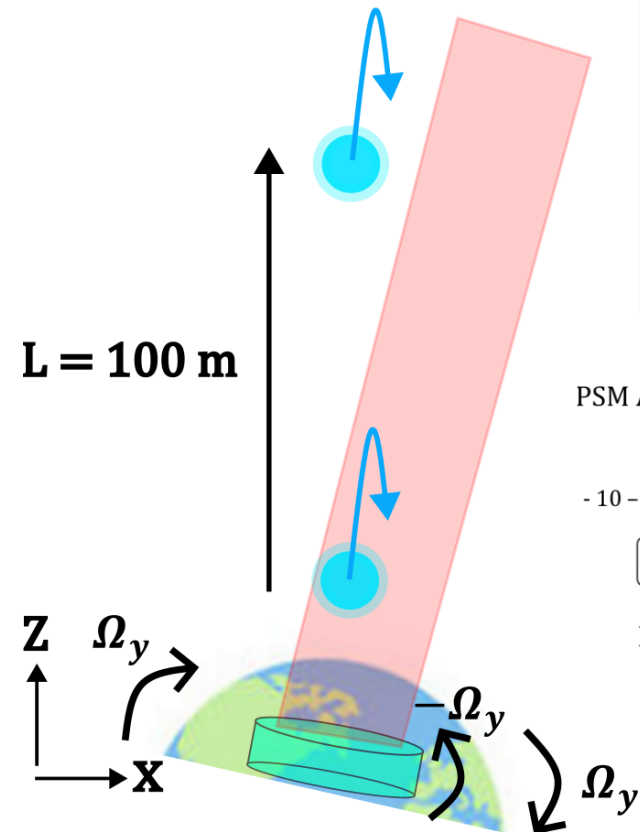
# Stanford MAGIS Prototype



- 10 m atom interferometer under construction at Stanford University (90% complete!)
- A prototype for MAGIS-100 with identical atom sources and laser system to develop technology and construction methods
- Main tower section installed, atom sources and laser system assembled and already producing science results



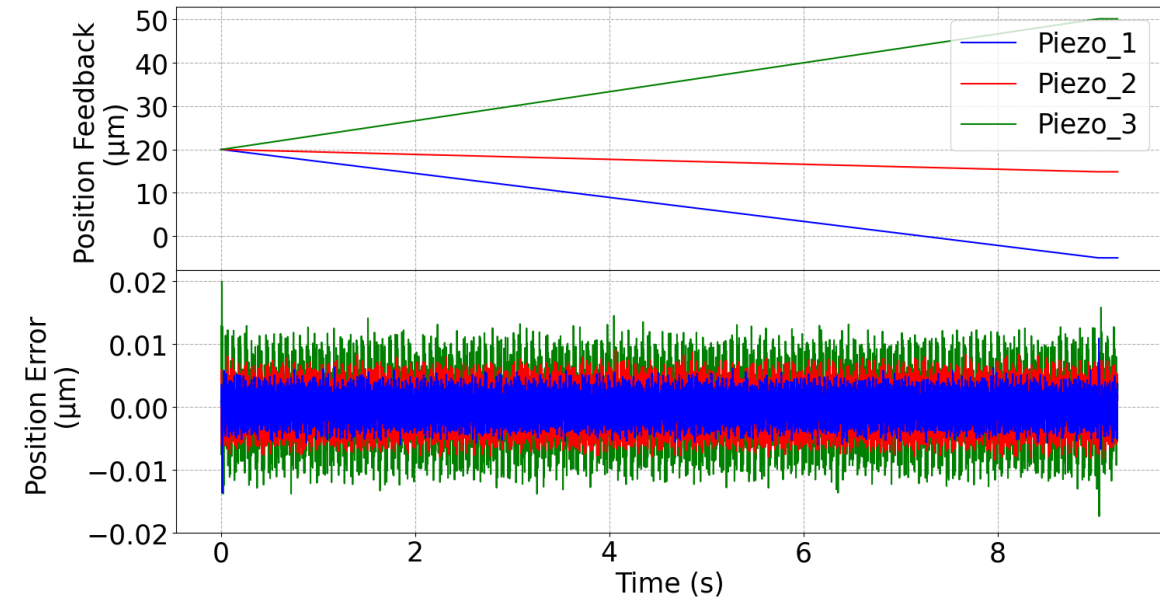
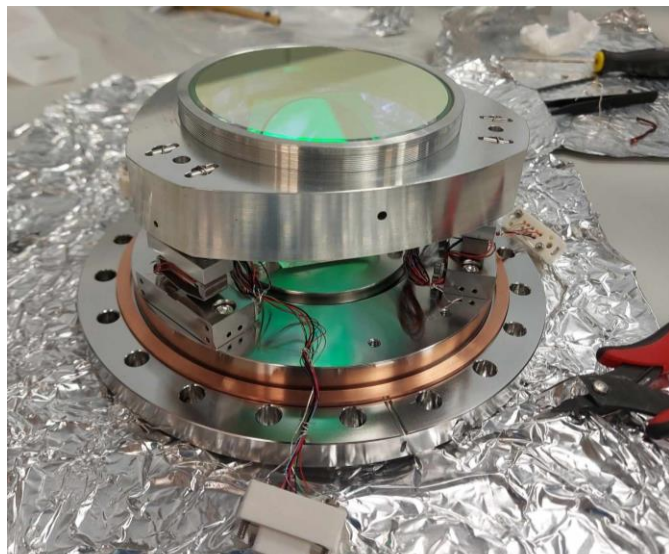
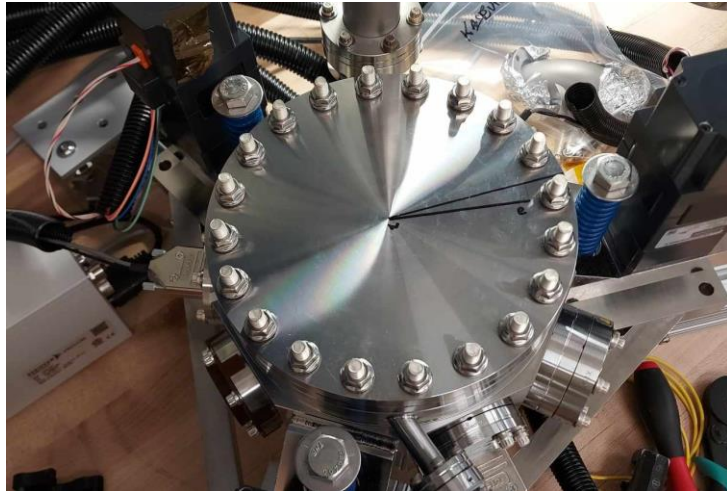
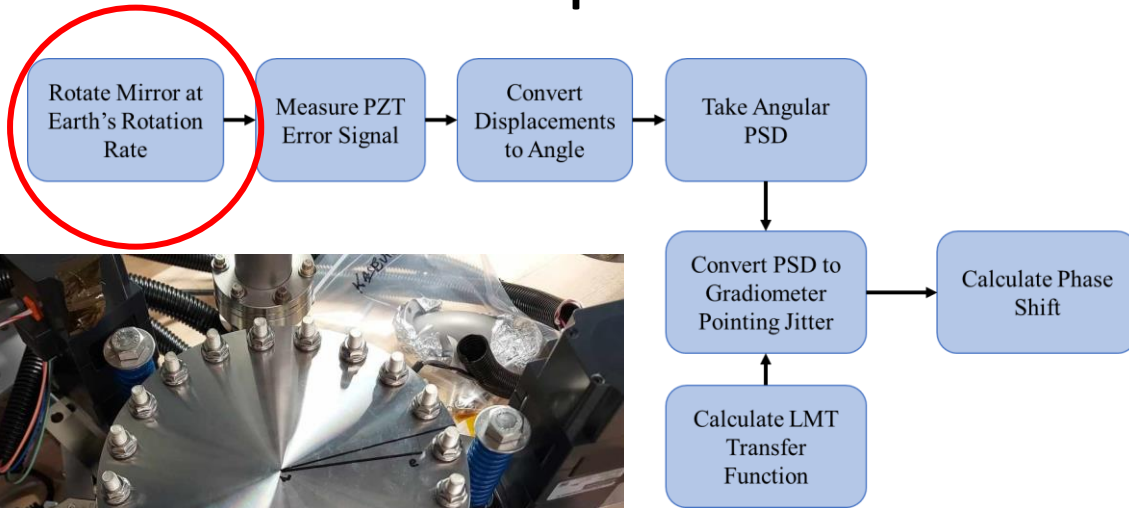
# Rotation Compensation System



- Long-baseline atom interferometers are very susceptible to the Coriolis force
- To compensate, laser pulses are counter rotated with a UHV tip-tilt mirror at the bottom of the tower
- Tip tilt mirror is controlled with tripod of PZT actuators
- Mirror rotation must be controlled to a nrad level of precision with servo control
- Additional optical monitoring system for secondary measurement, and future optical feedback loop



# Coriolis Compensation Sequence



- To test if the system was working to specifications, the mirror is rotated to match the rate required at Fermilab
- $41.841^\circ \text{ N} \rightarrow \cos(41.84) * 72.7 \mu\text{rads}^{-1} = 54.16 \mu\text{rads}^{-1}$
- $T = 9.03\text{s} \rightarrow \theta = 489.06 \mu\text{rad}$  (100 m fountain)
- Strain gauge sensors record the PZTs extensions, and the error signal of the servo is extracted
- How does this position error effect the interferometer?



# Pointing Jitter Laser Phase

- If the mirror is not perfectly flat, and has some aberrations it imprints a wavefront error on the laser beam:

$$\delta\phi_{wf} = \delta_A \sin(k_t x)$$

- If the mirror is tilted  $\delta\theta$ , the beam reaches the far interferometer with some transverse direction  $L\delta\theta$ . This shifts the wavefront error of the far interferometer:

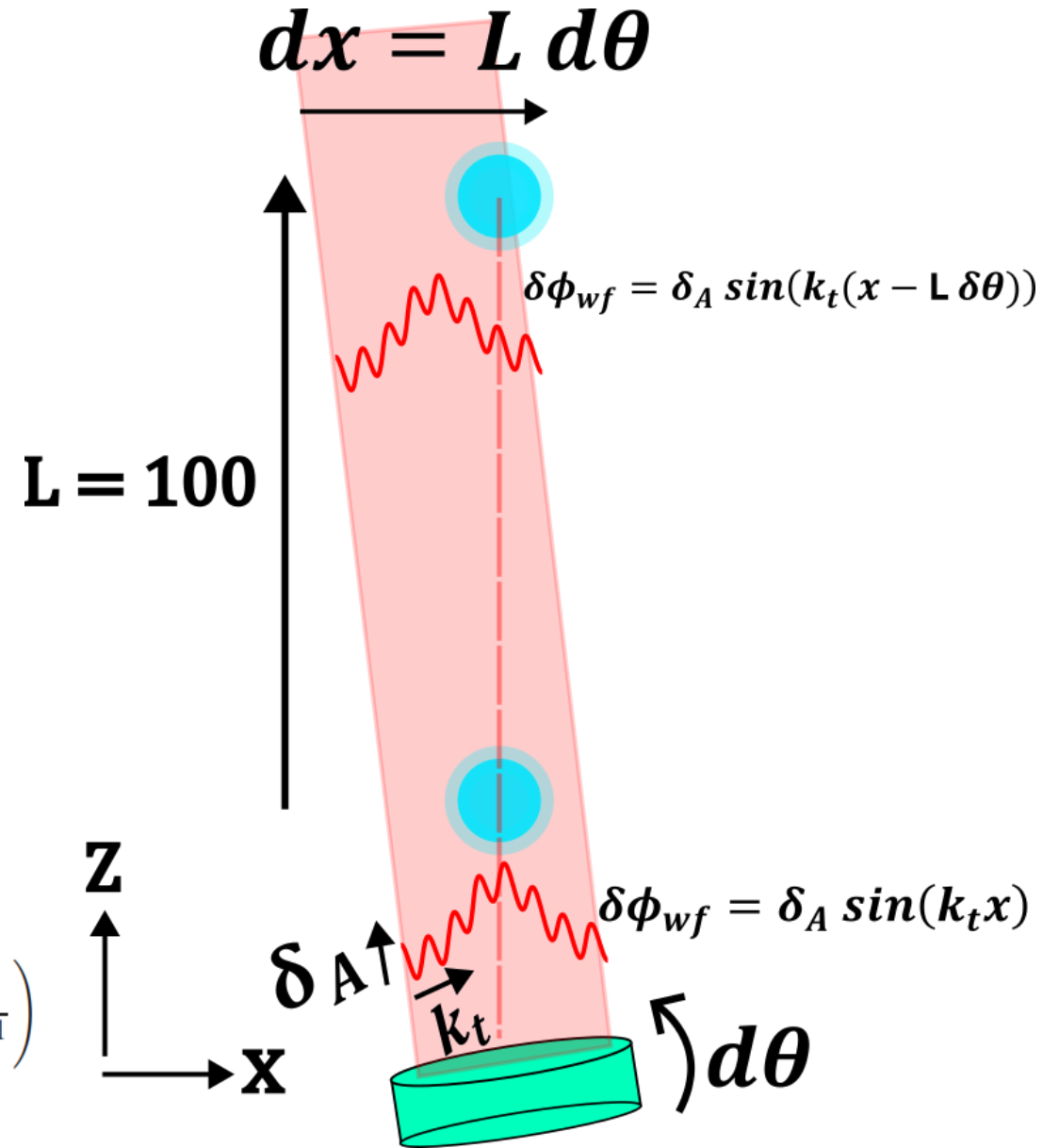
$$\delta\phi_{wf} = \delta_A \sin(k_t(x - L\delta\theta))$$

- For small  $x$  and  $L\delta\theta$ , we Taylor expand to estimate:

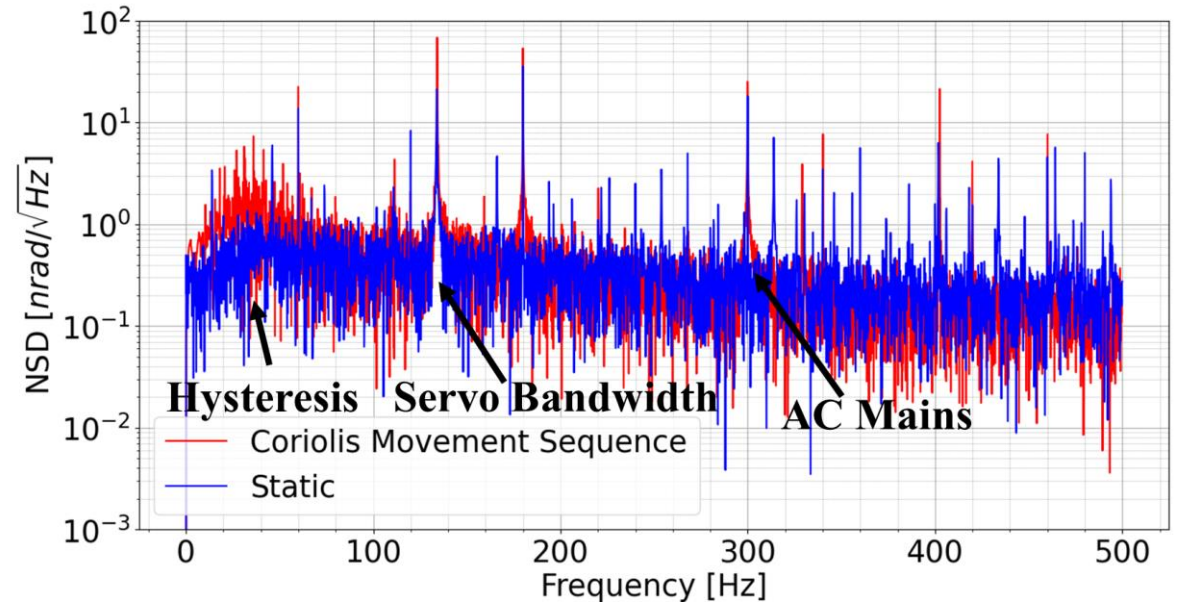
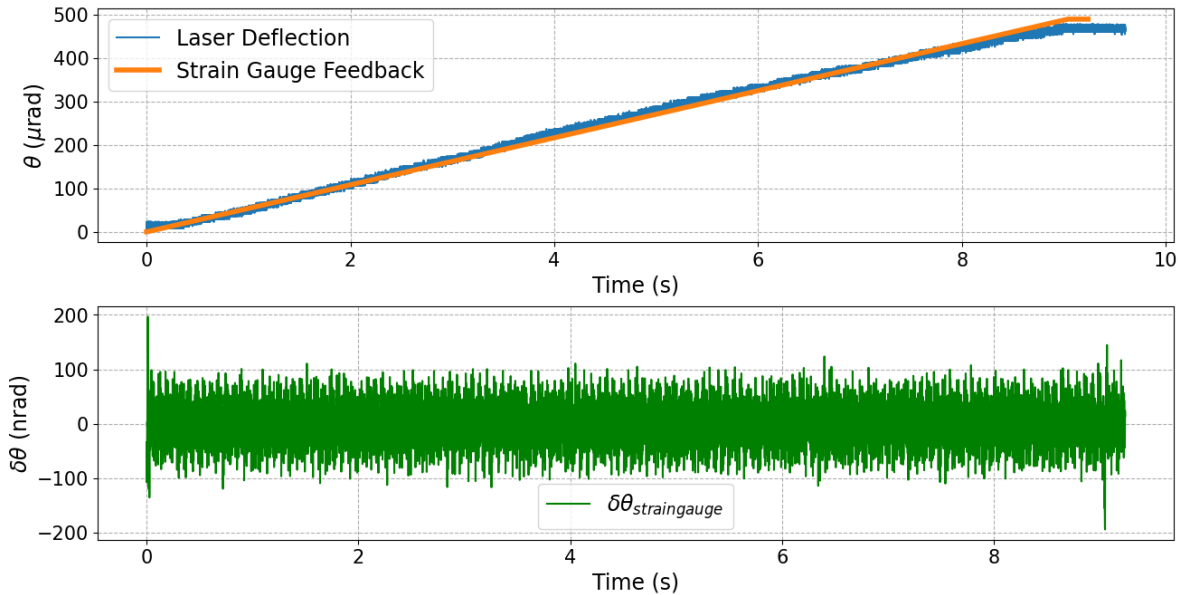
$$\delta\phi_{wf} \sim \delta_A k_t L \delta\theta$$

- For LMT of order  $n$  effect is imprinted  $n$  times.

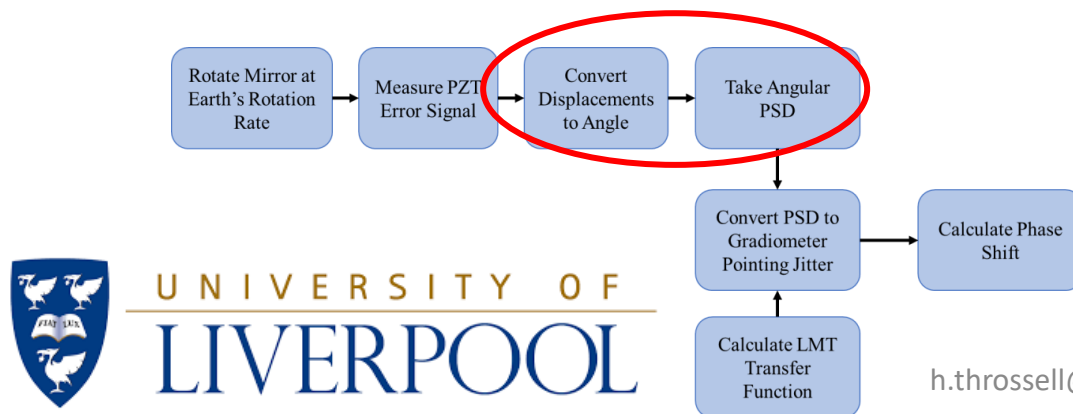
$$\delta\phi_{\text{Pointing}} \sim \left(6 \times 10^{-4} \text{ rad}/\sqrt{\text{Hz}}\right) \left(\frac{n}{100}\right) \left(\frac{\delta}{0.005}\right) \left(\frac{\delta\Phi}{30 \text{ nrad}/\sqrt{\text{Hz}}}\right) \left(\frac{k_t}{(3 \text{ mm})^{-1}}\right)$$



# Tilt Angle and Error



- PZT feedback and error signal converted to tilt angle
- Optical lever for angle monitoring
- RMS average  $\delta\theta = 33$  nrad
- Target system precision = 50 nrad



UNIVERSITY OF  
LIVERPOOL

# Variance of atom phase noise due to laser pointing jitter

$$\sigma_{\Phi}^2 = \int_0^{\infty} |H(\omega)|^2 S_{\phi}(\omega) \frac{d\omega}{2\pi}$$

TF of laser-atom interactions

Power spectral density of laser phase noise

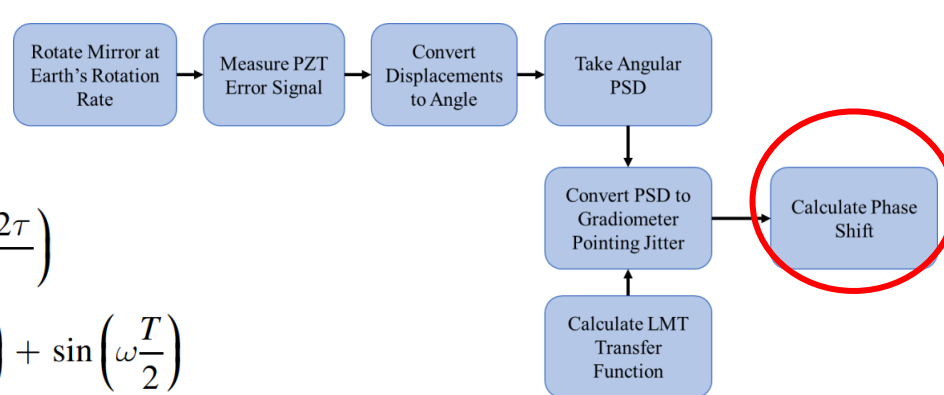
Phase response of atom interferometers based on sequential Bragg diffractions

$$S_{\phi}(\omega) = \delta_A k_t L \delta\phi(\omega)$$

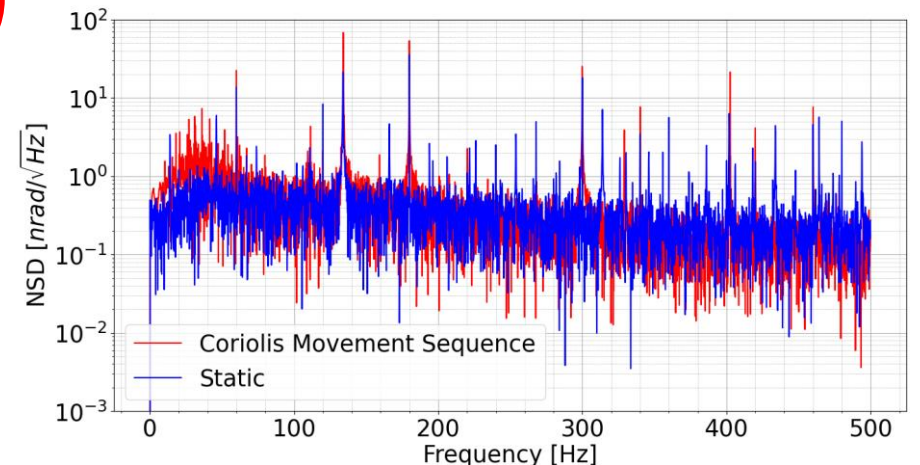
To cite this article: B Décamps *et al* 2019 *J. Phys. B: At. Mol. Opt. Phys.* **52** 015003

**$NSD^2$**

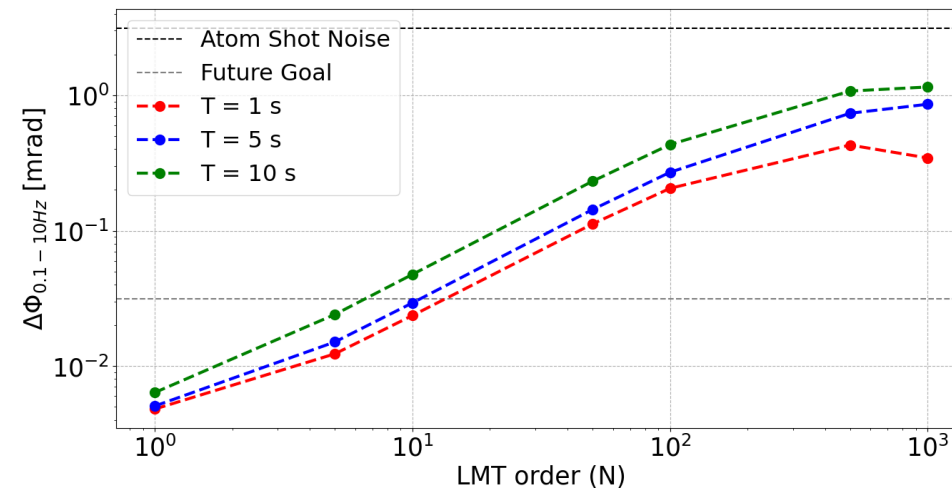
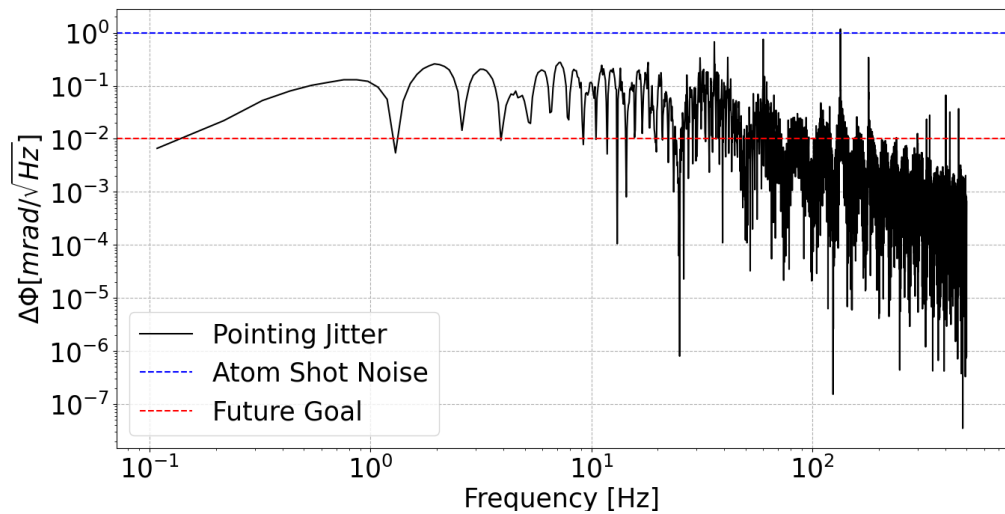
$$H(\omega) = \frac{4in\Omega_R^2}{\omega^2 - \Omega_R^2} \sin\left(\omega \frac{T + 2\tau}{2}\right) \times \left\{ \frac{\omega}{\Omega_R} \cos\left(\omega \frac{T + 2\tau}{2}\right) + \sin\left(\omega \frac{T}{2}\right) + \frac{\sin\left(\omega \frac{N(t_c + 2\tau)}{2}\right)}{\sin\left(\omega \frac{t_c + 2\tau}{2}\right)} \cos(\omega\tau) \times \sin\left(\omega \frac{T - (N + 1)t_c - 2N\tau}{2}\right) \right\}$$



[h.throssell@liverpool.ac.uk](mailto:h.throssell@liverpool.ac.uk)



# Atom Phase Shift due to Laser Pointing Jitter



Requirement	Design Target	Measured
angular range $\phi$ (mrad)	1.3	1.4
rms average $\delta\phi$ (nrad)	50	33
rms mirror flatness ( $\lambda$ )	0.001	$0.001 \pm 0.001$
servo settling time (ms)	100	$63.4 \pm 3.4$
pointing jitter phase shift (mrad)	6.00	0.46

- MAGIS-100 is designed to be noise limited by the statistical uncertainty in the number of atoms during detection
- The science sensitivity range of MAGIS-100 is 0.1-10 Hz
- Varying the MAGIS-100 experimental parameters to their limit, the system's noise does not exceed the atom shot noise
- Future goal phase sensitivity can be met with upgraded optical feedback system



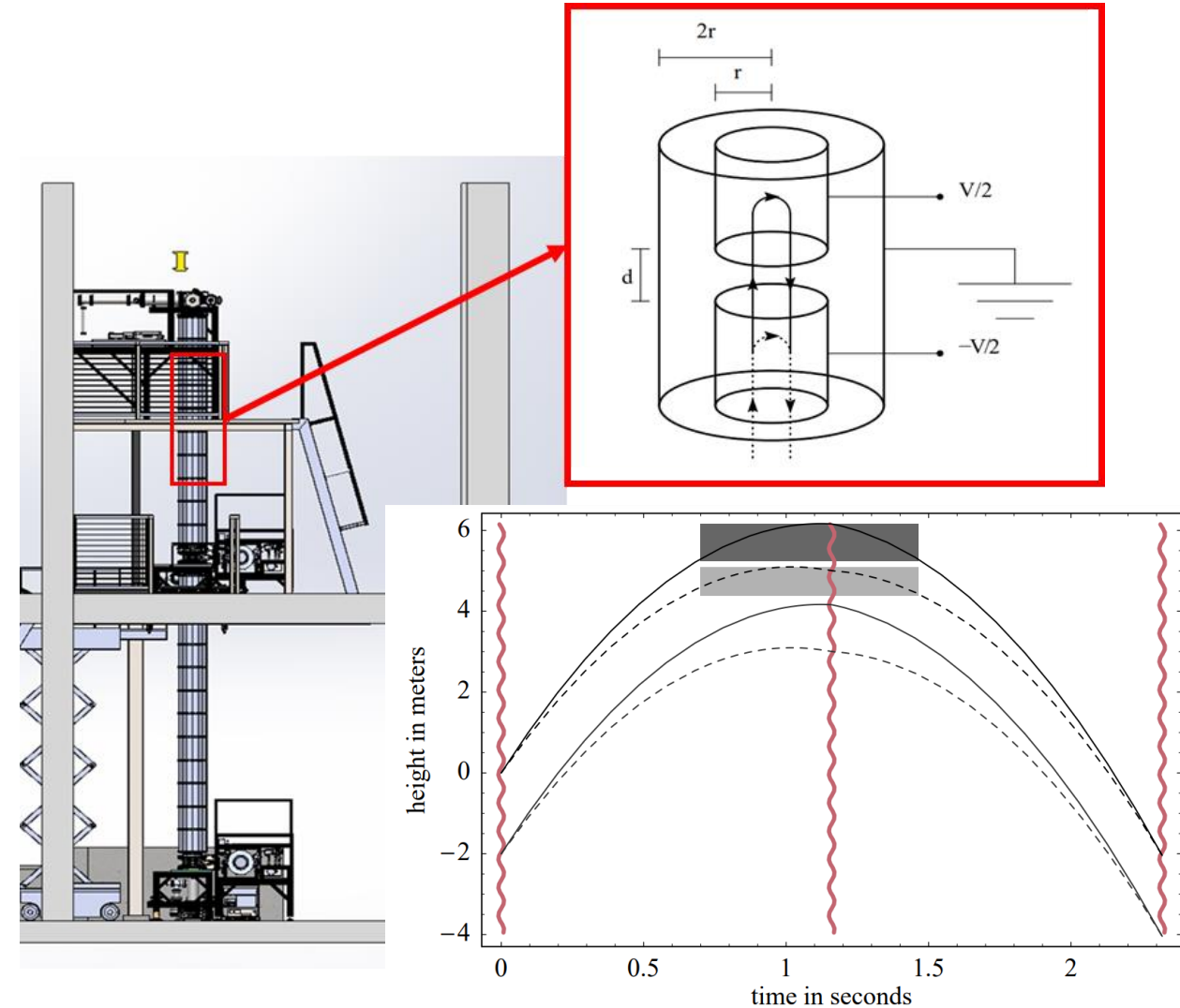
# Conclusion

- The RCS system has been successfully assembled and tested for the MAGIS prototype
- The final installation is planned for late summer
- The parts for the identical MAGIS-100 system have been shipped to Fermilab
- The PSD for the angular jitter has been measured for the tip tilt mirror
- A calculation of the associated phase shift due to laser pointing jitter is well below our target value
- Varying the experimental parameters of MAGIS-100 show that we are still not limited by this noise source
- We are working to further improve the angular jitter error using the optical lever as a position sensor / feedback loop
- This measurement and analysis is being prepared for an upcoming publication

# Back Up Slides

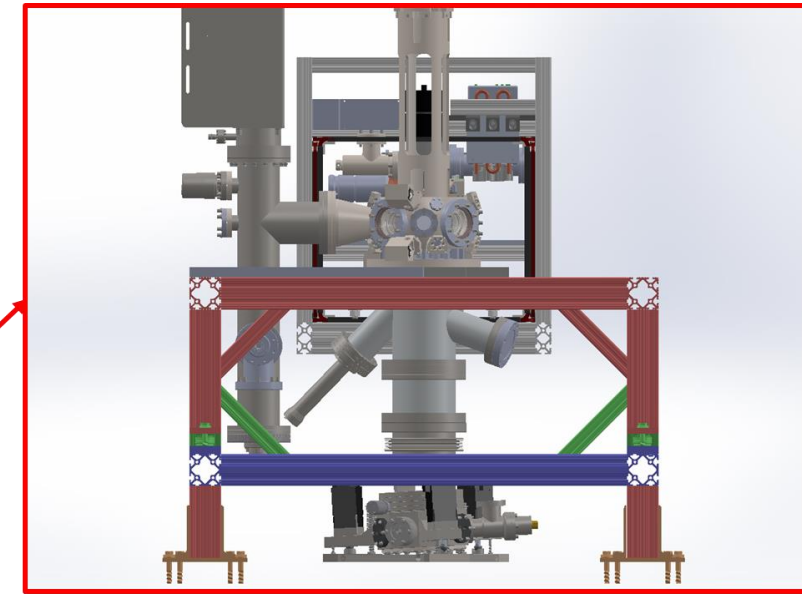
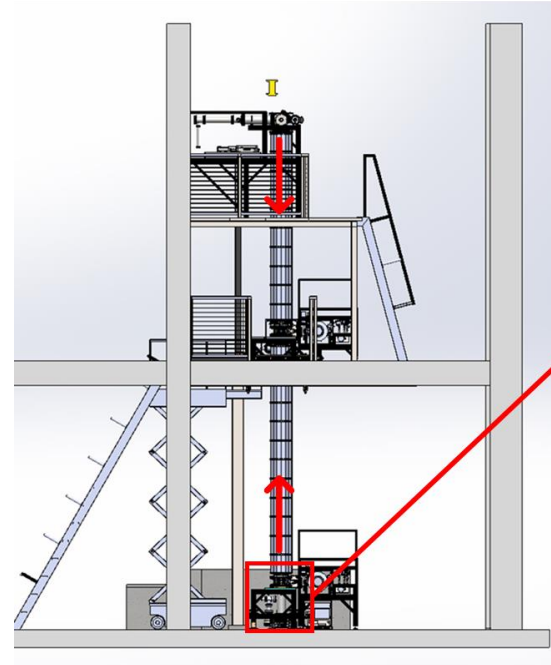
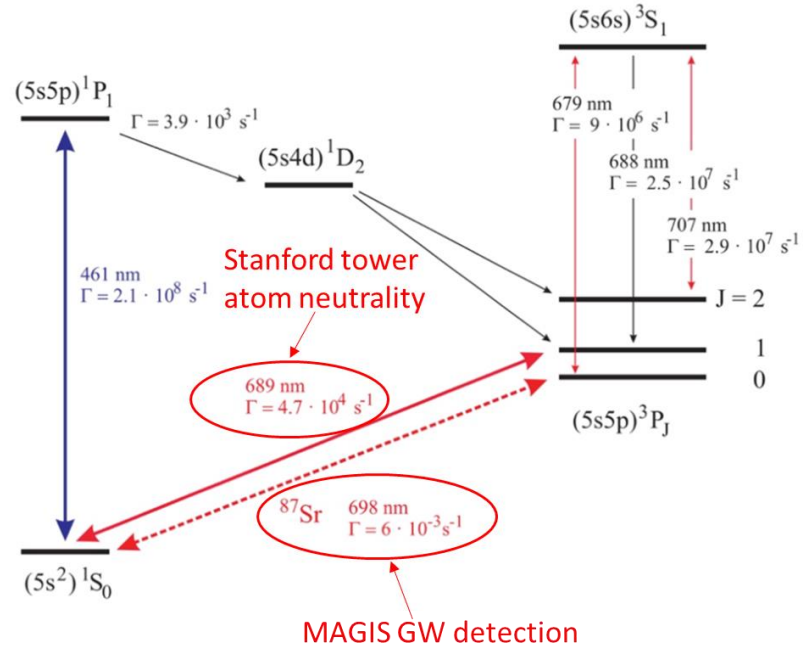
# Atom Neutrality Test with Atom Interferometry

- The Stanford Tower has been designed to test atom neutrality at the  $10^{-28}e$  level
- Atom interferometers can measure atom neutrality via the Aharonov-Bohm effect:
  - The atom ensemble is launched and spatially separated in a superposition
  - Each arm of the superposition enters a region of high electric field
  - The ensemble is brought back together
  - If the atom has a small charge  $\epsilon e$ , the wavefunction will accumulate phase  $= \frac{\epsilon e}{\hbar} V t$
- This requires a very large spatial separation of the atomic states ( $\approx 1$  m!)



Diagrams from: "Testing atom neutrality with an atom interferometer", A.Arvanitaki, Phys.Rev.Lett.100:120407 (2008)

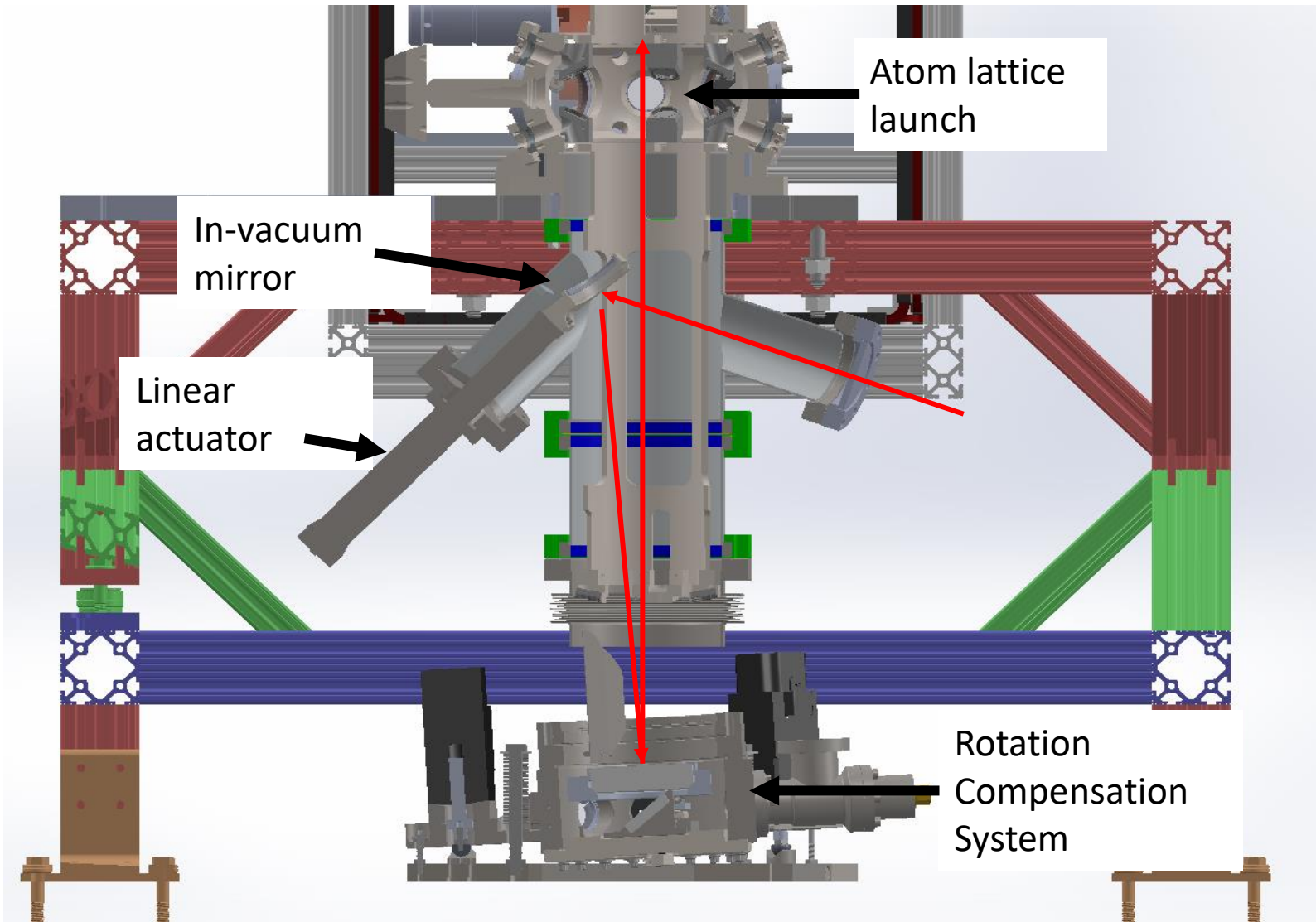
# Laser Injection System for Broadband Atom Interferometry



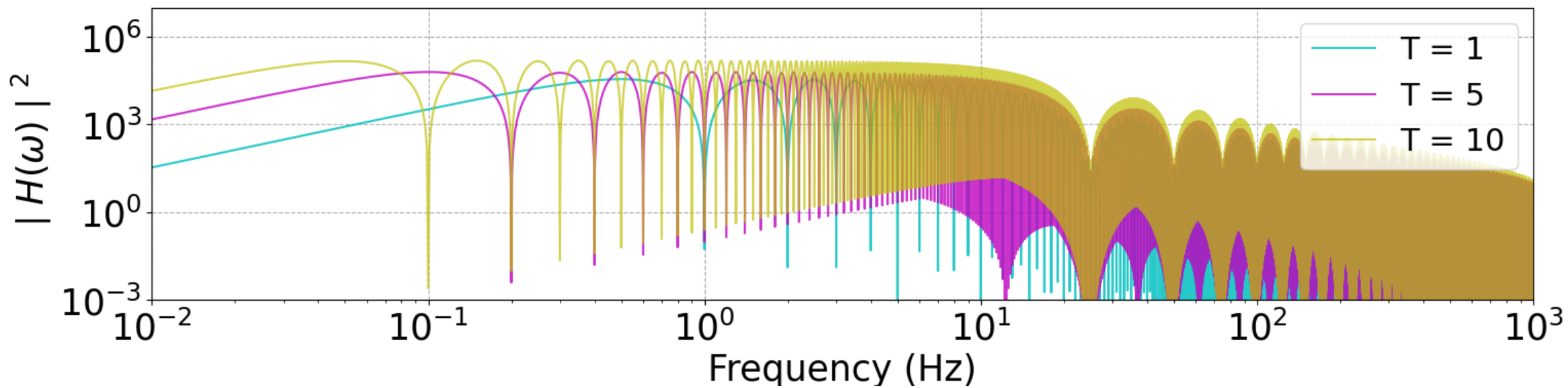
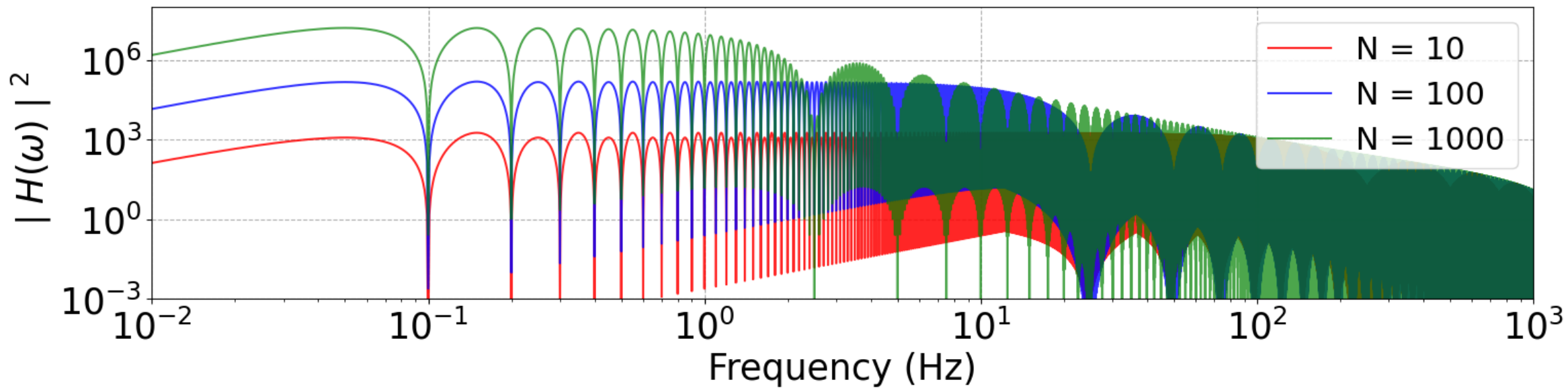
- The Stanford tower will test for atom neutrality with the ( $^1S_0 \rightarrow ^3P_1$ ) 689 nm transition of Sr-87
- Interferometry with large wave packet separations is easier to achieve with this transition
- 689 nm requires a laser injection from the lower section of the tower
- The tower will still operate in a 698 nm ( $^1S_0 \rightarrow ^3P_0$ ) mode for MAGIS prototyping

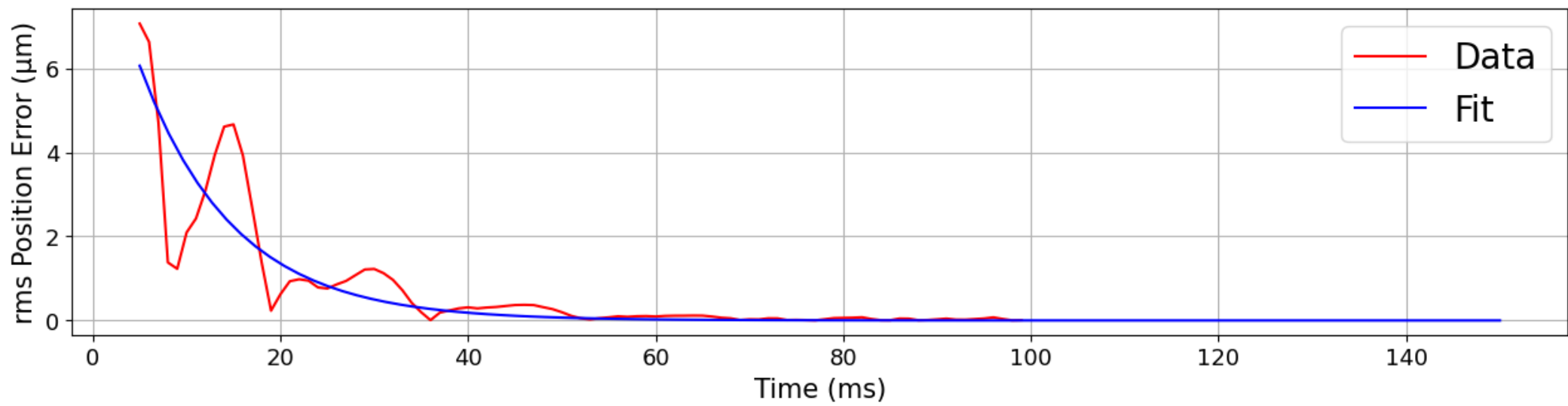
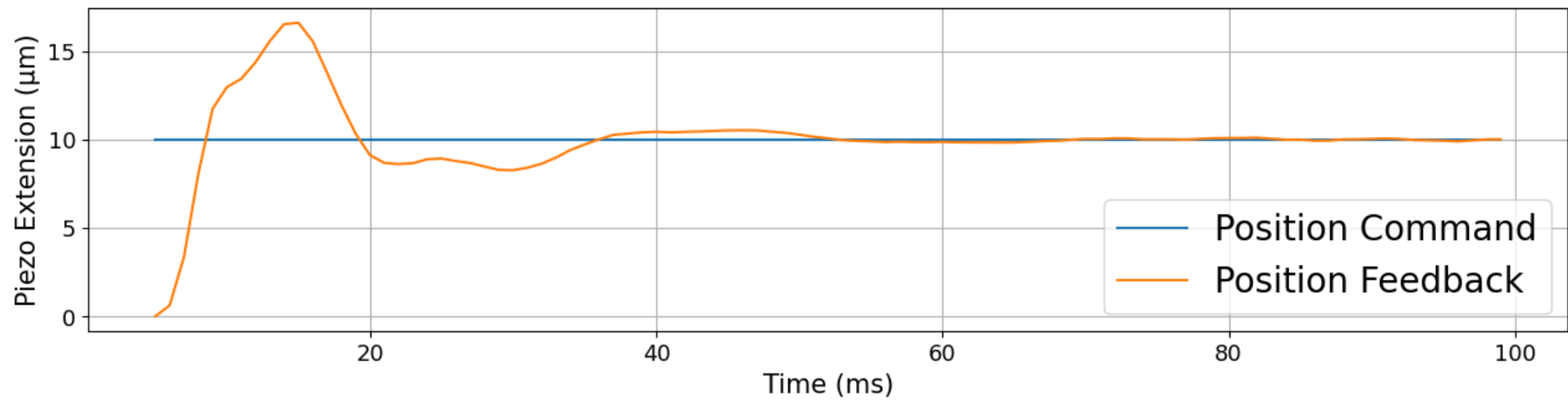


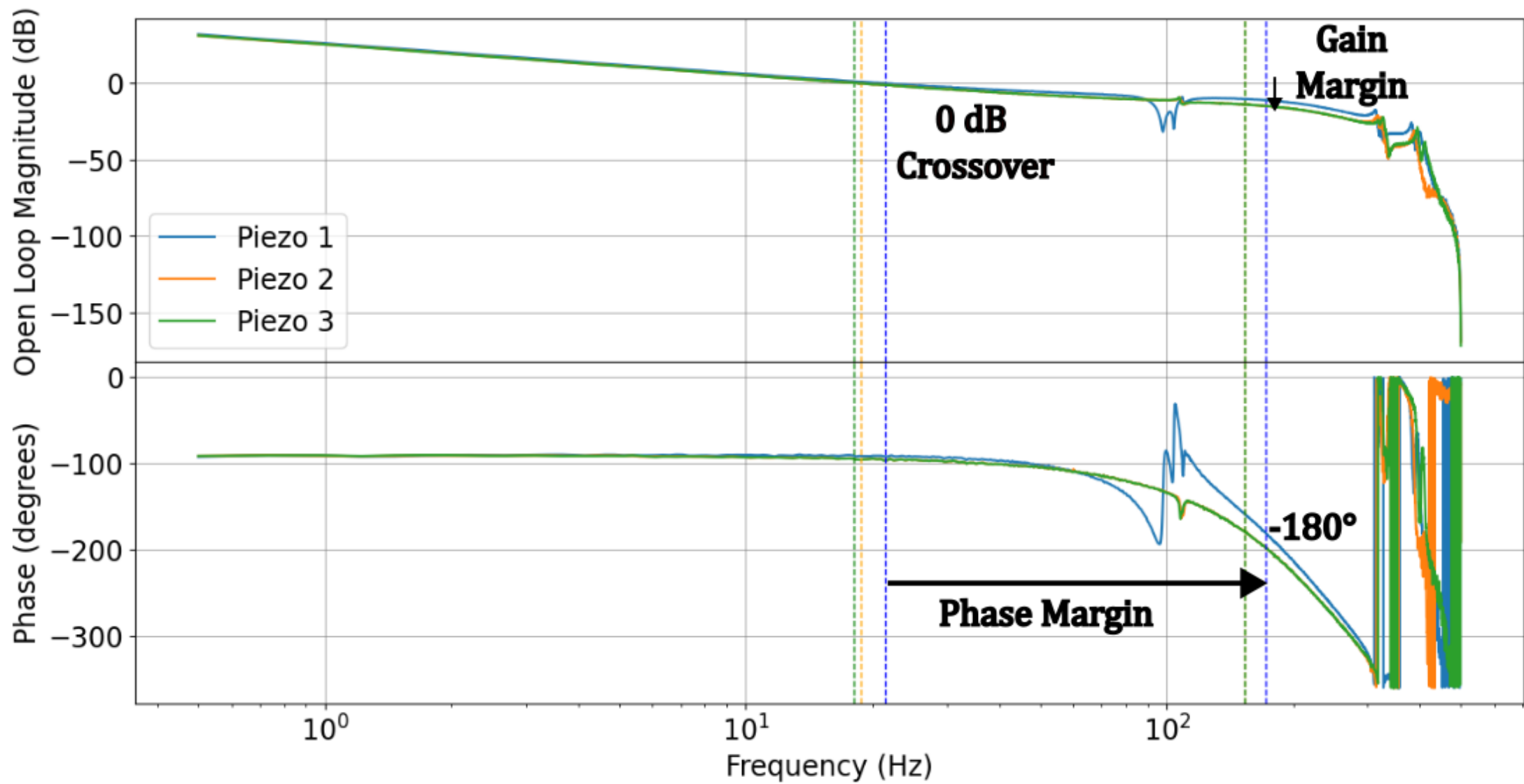
# Laser Injection System for Broadband Atom Interferometry

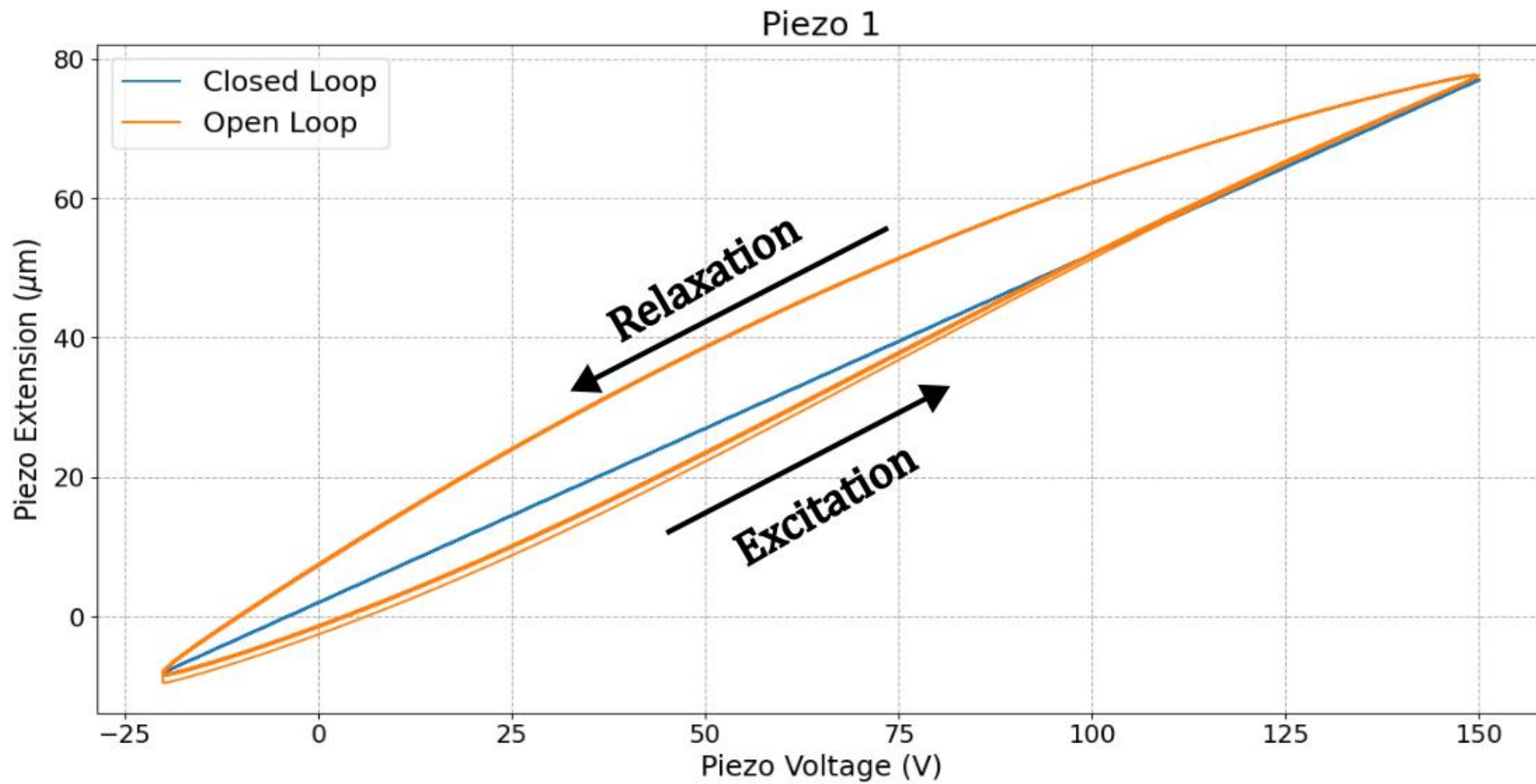


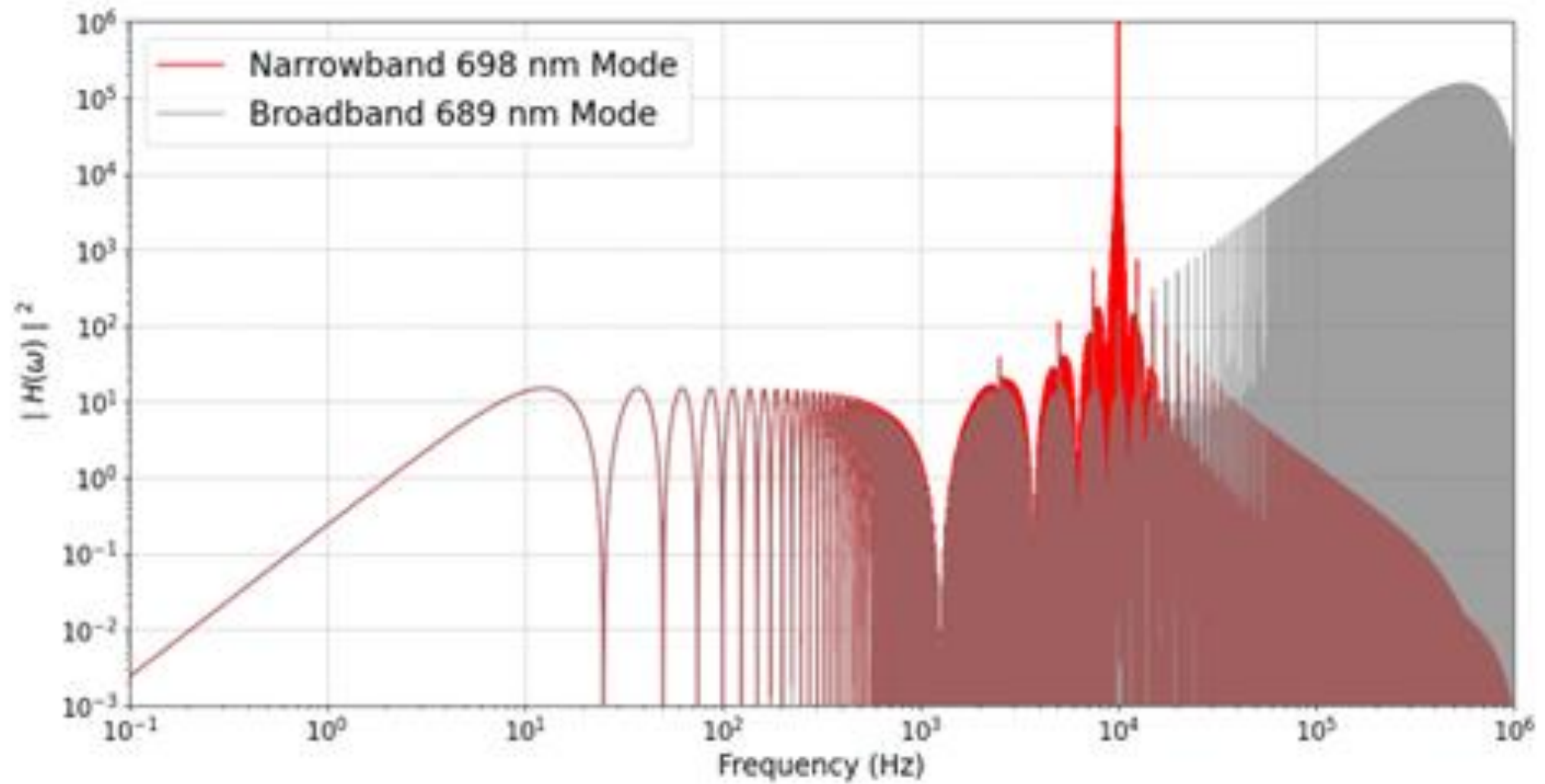
- 689 nm laser enters the tower via this angled tee vacuum chamber
- A retractable in-vacuum mirror reflects light down onto the tip tilt mirror
- The lower retro reflection chamber is tilted at  $3^\circ$  to reflect light upwards into the interferometry region
- Extended UHV bellows allow for flexible tilting of the retro reflection platform

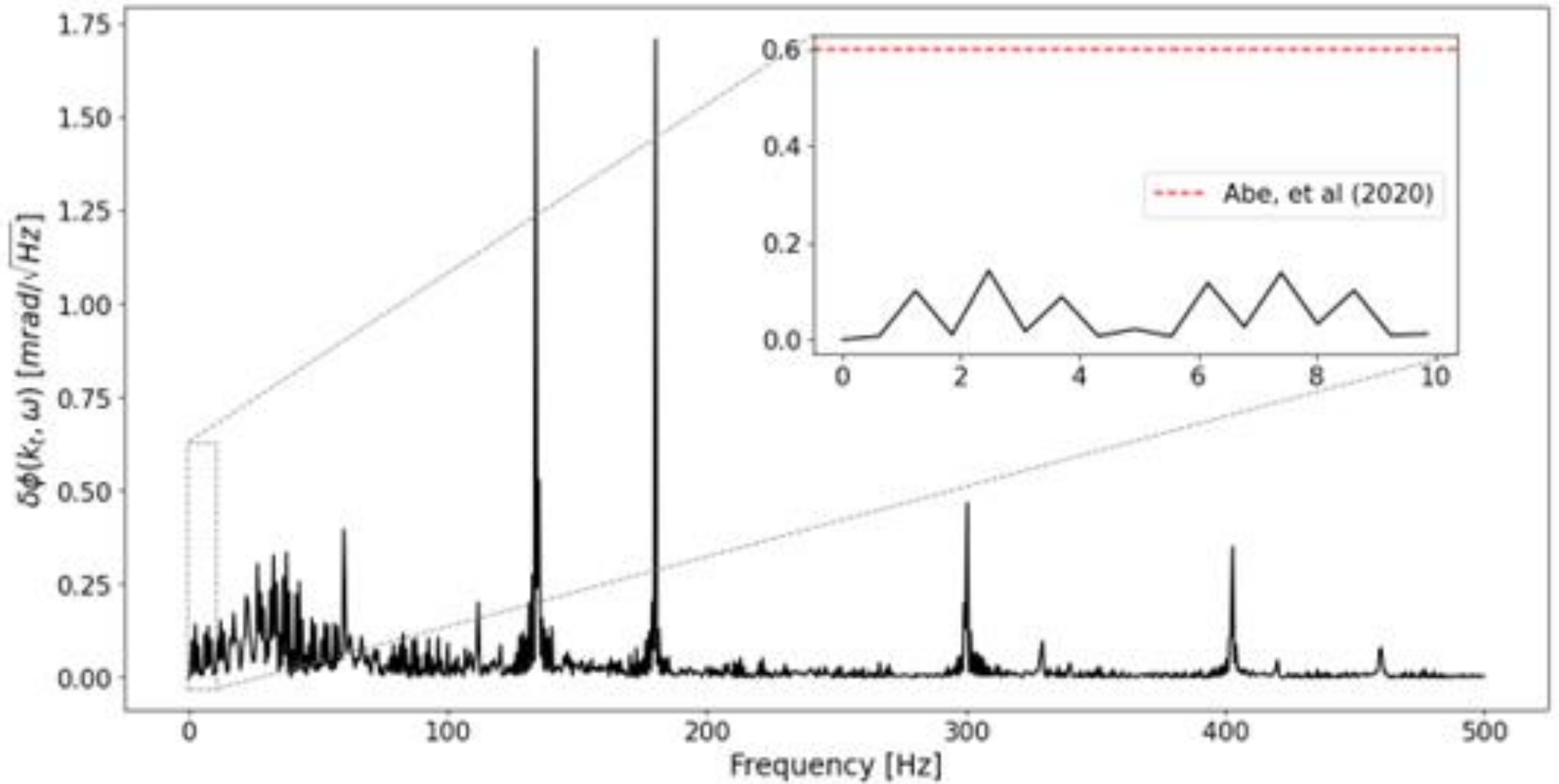


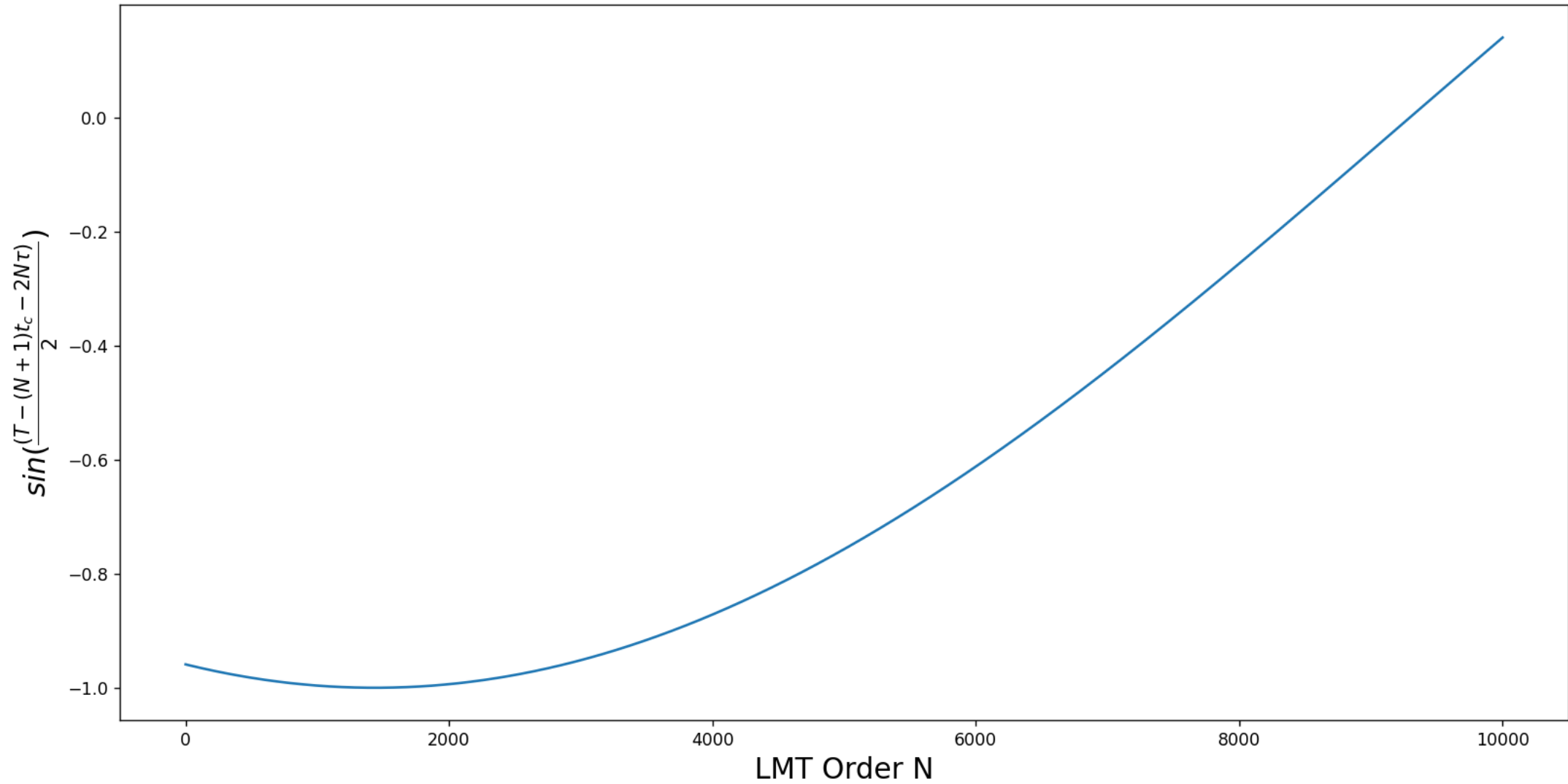












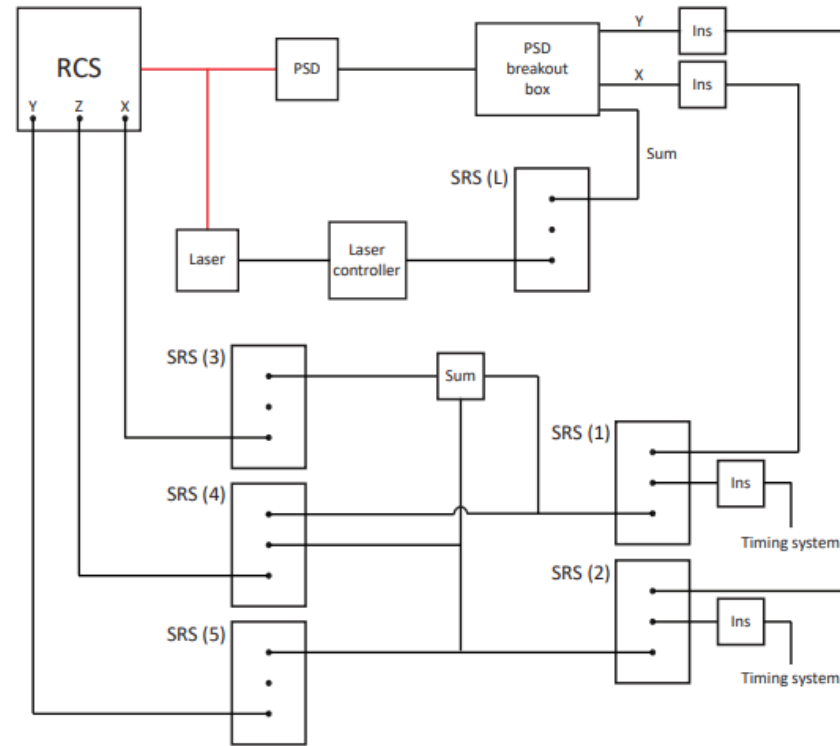


Figure 2.19: Schematic of RCS feedback system. SRS: Stanford Research Systems SIM960 Analog PID Controller. The upper point in each PID controller represents the input, the middle point represents the setpoint, and the lower point represents the output. PSD: On-Trak Photonics Inc. PSM 2-4 Position Sensing Module. PSD breakout box: On-Trak Photonics Inc. OT-301 Position Sensing Amplifier. Laser controller: Arroyo 6300 ComboSource. Laser: LPS-PM830-FC. Ins: instrumentation amplifier.

