



Status and plans of the Compact Linear Collider

Philip Burrows

John Adams Institute

Oxford University

On behalf of the CLIC Collaborations

Thanks to all colleagues for materials



CLIC Collaborations

31 Countries – over 70 Institutes

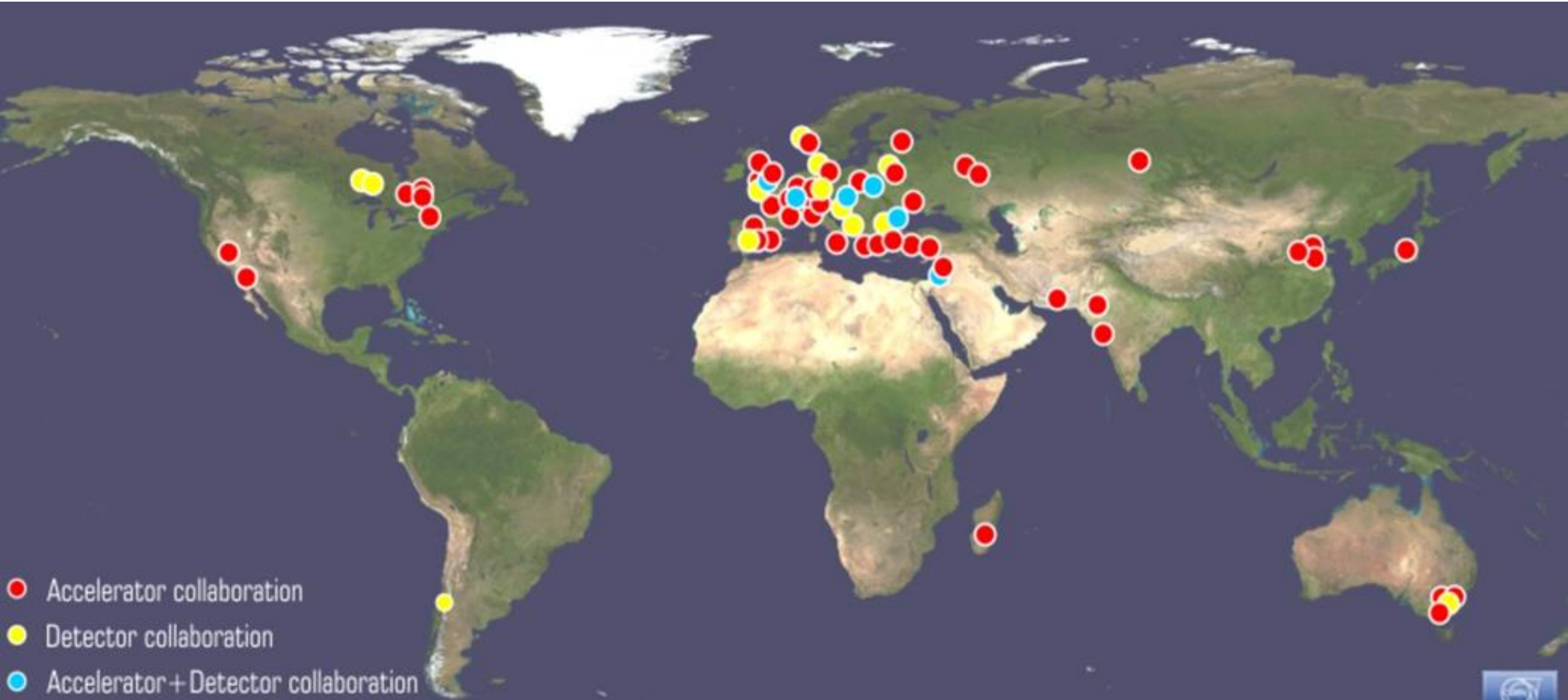



Outline

- **Brief introduction to CLIC**
- **Energy staging**
- **A few R&D highlights**
- **Strategic plans → 2019 and beyond**

Apologies for skipping many results + details



CLIC layout (3 TeV)

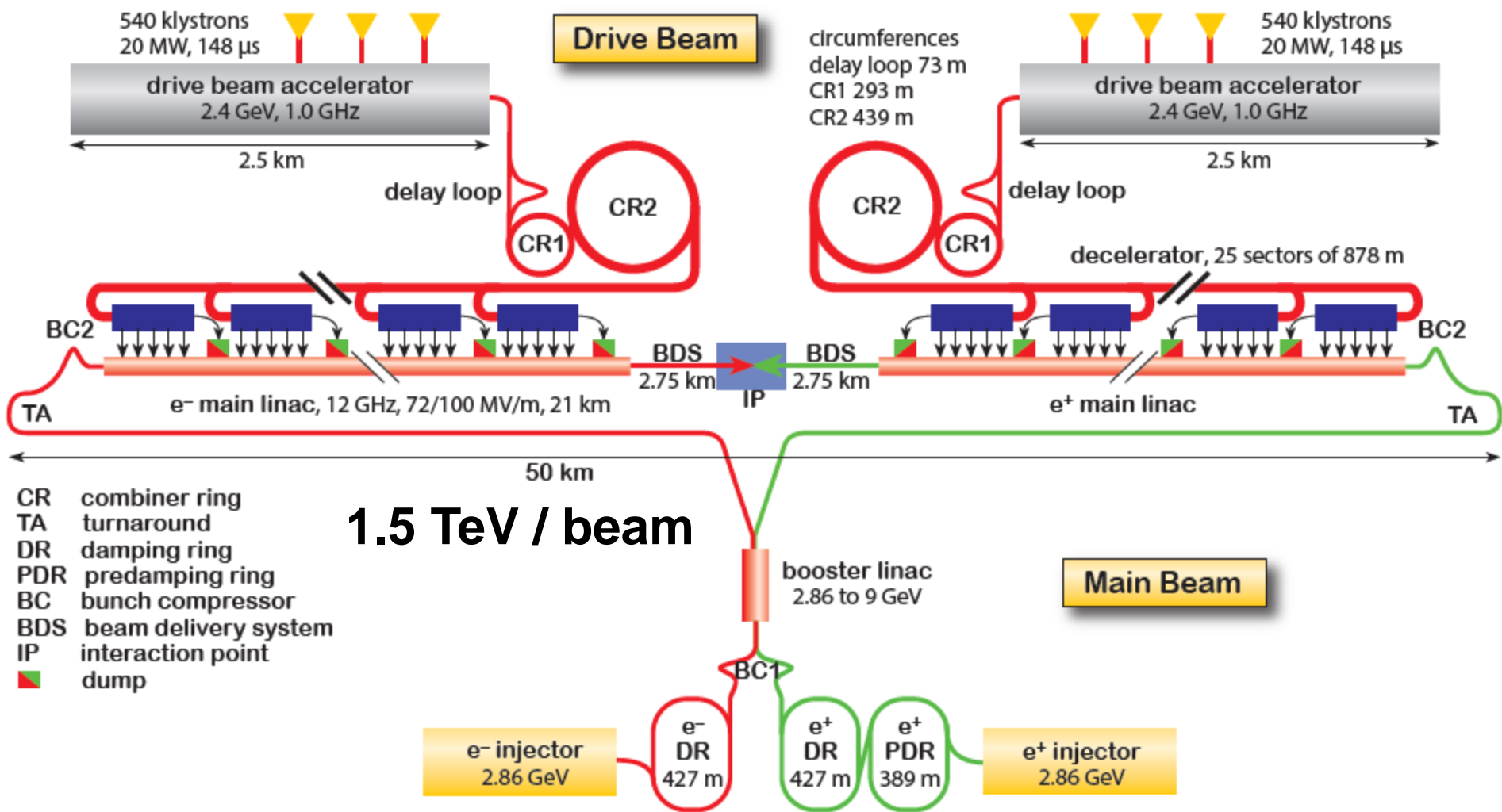

CLIC physics context

Energy-frontier capability for electron-positron collisions, for precision exploration of potential new physics that may emerge from LHC

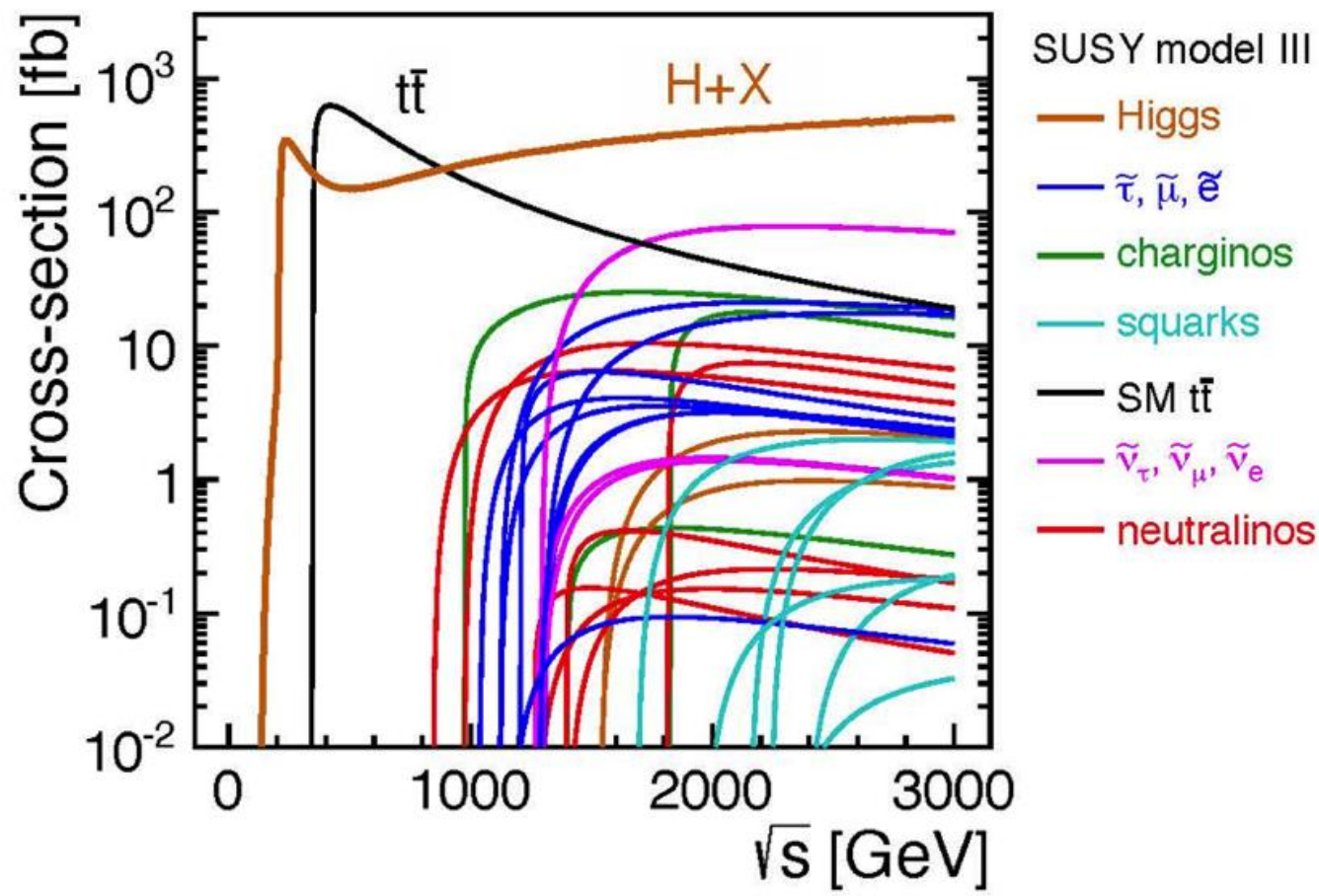

CLIC physics context

Energy-frontier capability for electron-positron collisions,

for precision exploration of potential new physics that may emerge from LHC

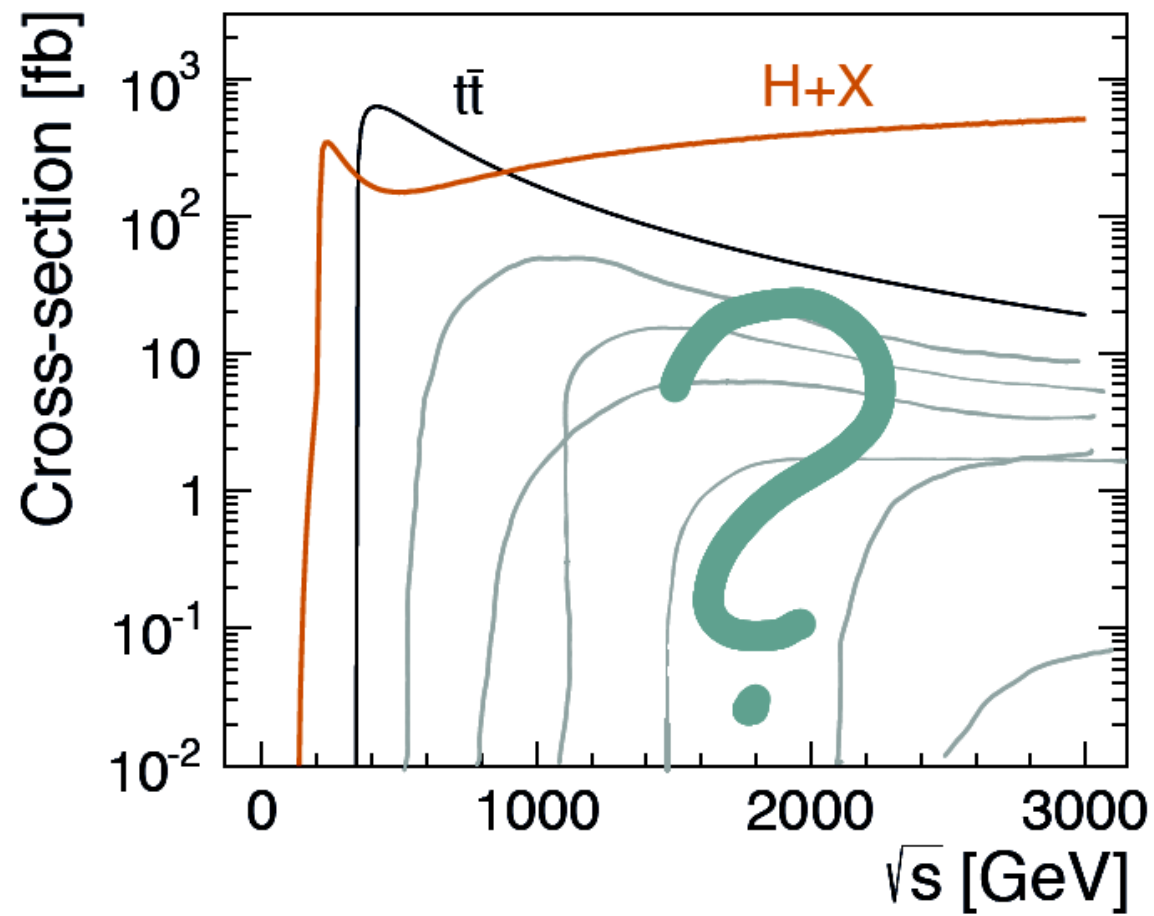



CERN scientific strategy: 3 main pillars

Full exploitation of the LHC:

- ❑ successful operation of the nominal LHC (Run 2, LS2, Run 3)
- ❑ construction and installation of LHC upgrades: LIU (LHC Injectors Upgrade) and HL-LHC

Scientific diversity programme serving a broad community:

- ❑ current experiments and facilities at Booster, PS, SPS and their upgrades (Antiproton Decelerator/ELENA, ISOLDE/HIE-ISOLDE, etc.)
- ❑ participation in accelerator-based neutrino projects outside Europe (presently mainly LBNF in the US) through CERN Neutrino Platform

Preparation of CERN's future:

- ❑ vibrant accelerator R&D programme exploiting CERN's strengths and uniqueness (including superconducting high-field magnets, AWAKE, etc.)
- ❑ design studies for future accelerators: CLIC, FCC (includes HE-LHC)
- ❑ future opportunities of scientific diversity programme ("Physics Beyond Colliders" Study Group)

Important milestone: update of the European Strategy for Particle Physics (ESPP), to be concluded in May 2020



CERN scientific strategy: 3 main pillars

Full exploitation of the LHC:

- ❑ successful operation of the nominal LHC (Run 2, LS2, Run 3)
- ❑ construction and installation of LHC upgrades: LIU (LHC Injectors Upgrade) and HL-LHC

Scientific diversity programme serving a broad community:

- ❑ current experiments and facilities at Booster, PS, SPS and their upgrades (Antiproton Decelerator/ELENA, ISOLDE/HIE-ISOLDE, etc.)
- ❑ participation in accelerator-based neutrino projects outside Europe (presently mainly LBNF in the US) through CERN Neutrino Platform

Preparation of CERN's future:

- ❑ vibrant accelerator R&D programme exploiting CERN's strengths and uniqueness (including superconducting high-field magnets, AWAKE, etc.)
- ❑ design studies for future accelerators: CLIC, FCC (includes HE-LHC)
- ❑ future opportunities of scientific diversity programme ("Physics Beyond Colliders" Study Group)

Important milestone: update of the European Strategy for Particle Physics (ESPP), to be concluded in May 2020



CERN scientific strategy: 3 main pillars

Full exploitation of the LHC:

- ❑ successful operation of the nominal LHC (Run 2, LS2, Run 3)
- ❑ construction and installation of LHC upgrades: LIU (LHC Injectors Upgrade) and HL-LHC

Scientific diversity programme serving a broad community:

- ❑ current experiments and facilities at Booster, PS, SPS and their upgrades (Antiproton Decelerator/ELENA, ISOLDE/HIE-ISOLDE, etc.)
- ❑ participation in accelerator-based neutrino projects outside Europe (presently mainly LBNF in the US) through CERN Neutrino Platform

Preparation of CERN's future:

- ❑ vibrant accelerator R&D programme exploiting CERN's strengths and uniqueness (including superconducting high-field magnets, AWAKE, etc.)
- ❑ design studies for future accelerators: CLIC, FCC (includes HE-LHC)
- ❑ future opportunities of scientific diversity programme ("Physics Beyond Colliders" Study Group)

We are vigorously preparing input for European Strategy PP Update:

- Project Plan for CLIC as a credible post-LHC option for CERN**
- Initial costs compatible with current CERN budget**
- Upgradeable in stages over 20-30 years**



CLIC Review

CLIC Accelerator Study – Review of objectives for the MTP 2016-2019

March 1st, 2016

Report from the Review Panel

Members: O. Brüning; P. Collier, J.M. Jimenez, R. Losito; R. Saban, R. Schmidt;
F. Sonnemann; M. Vretenar (Chair).

Introduction and general remarks

The Panel was very impressed by the enormous amount of work that was presented, by the enthusiasm of the CLIC team and by the wealth of knowledge accumulated by the CLIC study. The CLIC accelerator study has reached a high level of maturity and has been able to establish a large community consisting in about 50 collaborating laboratories and universities, working together on a number of technical challenges

After the publication of the Conceptual Design report in 2012, the CLIC Study is presently in the Development Phase, to prepare a more detailed design and an implementation plan for the next European Strategy Upgrade in 2018-19. This phase is expected to be followed by a Preparation Phase covering the period 2019-25; in case of a positive decision, a construction

Key recommendations

- **Produce optimized, staged design: 380 GeV → 3 TeV**
- **Optimise cost and power consumption**
- **Support efforts to develop high-efficiency klystrons**
- **Develop 380 GeV klystron-only version as alternative**
- **Consolidate high-gradient structure test results**
- **Develop plans for 2020-25 ('preparation phase')**
- **Continue and enhance participation in KEK/ATF2**



Organisation

- **Beam dynamics and design** (D. Schulte et al)
- **X-band RF, including high-efficiency klystrons** (W. Wuensch et al)
- **Main linac module and drive beam front end** (S. Doebert et al)
- **Technical systems** (N. Catalan et al)
- **General, incl. ATF2, ILC, CTF3, CLEAR** (S. Stapnes et al)

Organisation

- **Beam dynamics and design** (D. Schulte et al)
- **X-band RF, including high-efficiency klystrons** (W. Wuensch et al)
- **Main linac module and drive beam front end** (S. Doebert et al)
- **Technical systems** (N. Catalan et al)
- **General, incl. ATF2, ILC, CTF3, CLEAR** (S. Stapnes et al)

New implementation WGs preparing for European Strategy input:

- **Baseline parameters and design** (D. Schulte et al)
- **Civil engineering, infrastructure, siting** (J. Osborne et al)
- **Cost, power, schedule** (S. Stapnes et al)
- **Main linac hardware baselining** (C. Rossi et al)
- **Novel accelerator methods for future CLIC stages** (E. Adli et al)



'Rebaselining'

Optimize machine design w.r.t. cost and power for a staged approach to reach multi-TeV scales:

- ~ 380 GeV (optimised for Higgs + top physics)**
- ~ 1500 GeV**
- ~ 3000 GeV**

Adapting appropriately to LHC + other physics findings

Possibility for first physics no later than 2035

Project Plan to include accelerator, detector, physics

Rebaselining document

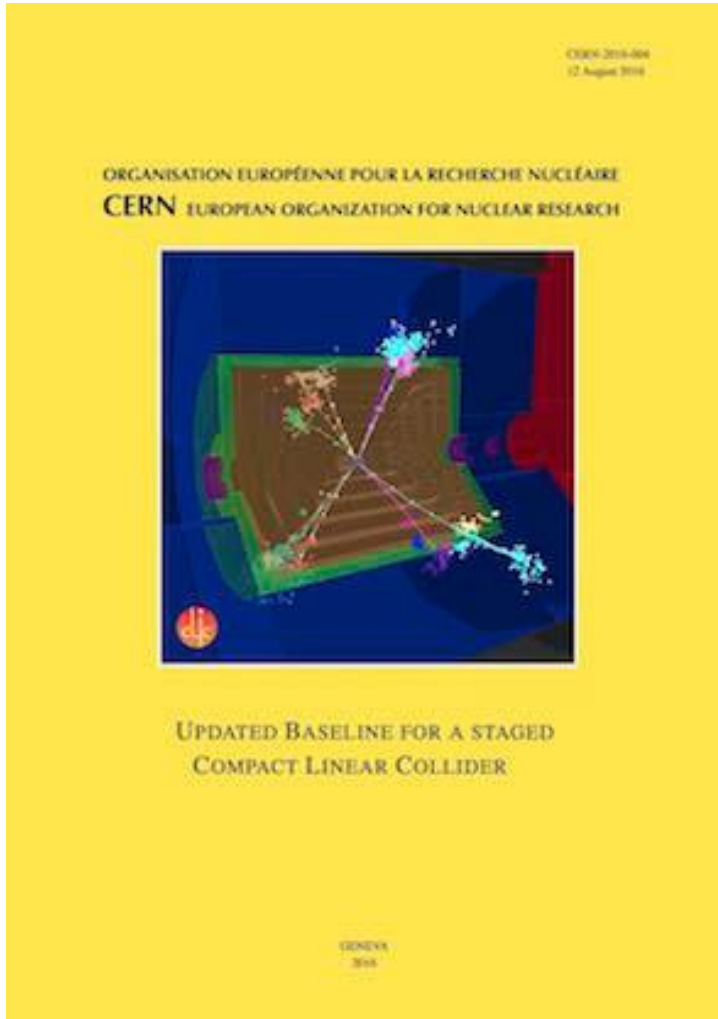

The Compact Linear Collider (CLIC) is a multi-TeV high-luminosity linear e^+e^- collider under development. For an optimal exploitation of its physics potential, CLIC is foreseen to be built and operated in a staged approach with three centre-of-mass energy stages ranging from a few hundred GeV up to 3 TeV. The first stage will focus on precision Standard Model physics, in particular Higgs and top measurements. Subsequent stages will focus on measurements of rare Higgs processes, as well as searches for new physics processes and precision measurements of new states, e.g. states previously discovered at LHC or at CLIC itself. In the 2012 CLIC Conceptual Design Report, a fully optimised 3 TeV collider was presented, while the proposed lower energy stages were not studied to the same level of detail. This report presents an updated baseline staging scenario for CLIC. The scenario is the result of a comprehensive study addressing the performance, cost and power of the CLIC accelerator complex as a function of centre-of-mass energy and it targets optimal physics output based on the current physics landscape. The optimised staging scenario foresees three main centre-of-mass energy stages at 380 GeV, 1.5 TeV and 3 TeV for a full CLIC programme spanning 22 years. For the first stage, an alternative to the CLIC drive beam scheme is presented in which the main linac power is produced using X-band klystrons.

CERN-2016-004

[arXiv:1608.07537](https://arxiv.org/abs/1608.07537)

**New reference plots for physics, luminosity,
power, costs ...**

Rebaselining: first stage energy ~ 380 GeV

Parameter	Unit	380 GeV	3 TeV
Centre-of-mass energy	TeV	0.38	3
Total luminosity	$10^{34}\text{cm}^{-2}\text{s}^{-1}$	1.5	5.9
Luminosity above 99% of v_s	$10^{34}\text{cm}^{-2}\text{s}^{-1}$	0.9	2.0
Repetition frequency	Hz	50	50
Number of bunches per train		352	312
Bunch separation	ns	0.5	0.5
Acceleration gradient	MV/m	72	100
Site length	km	11	50



New CLIC layout 380 GeV

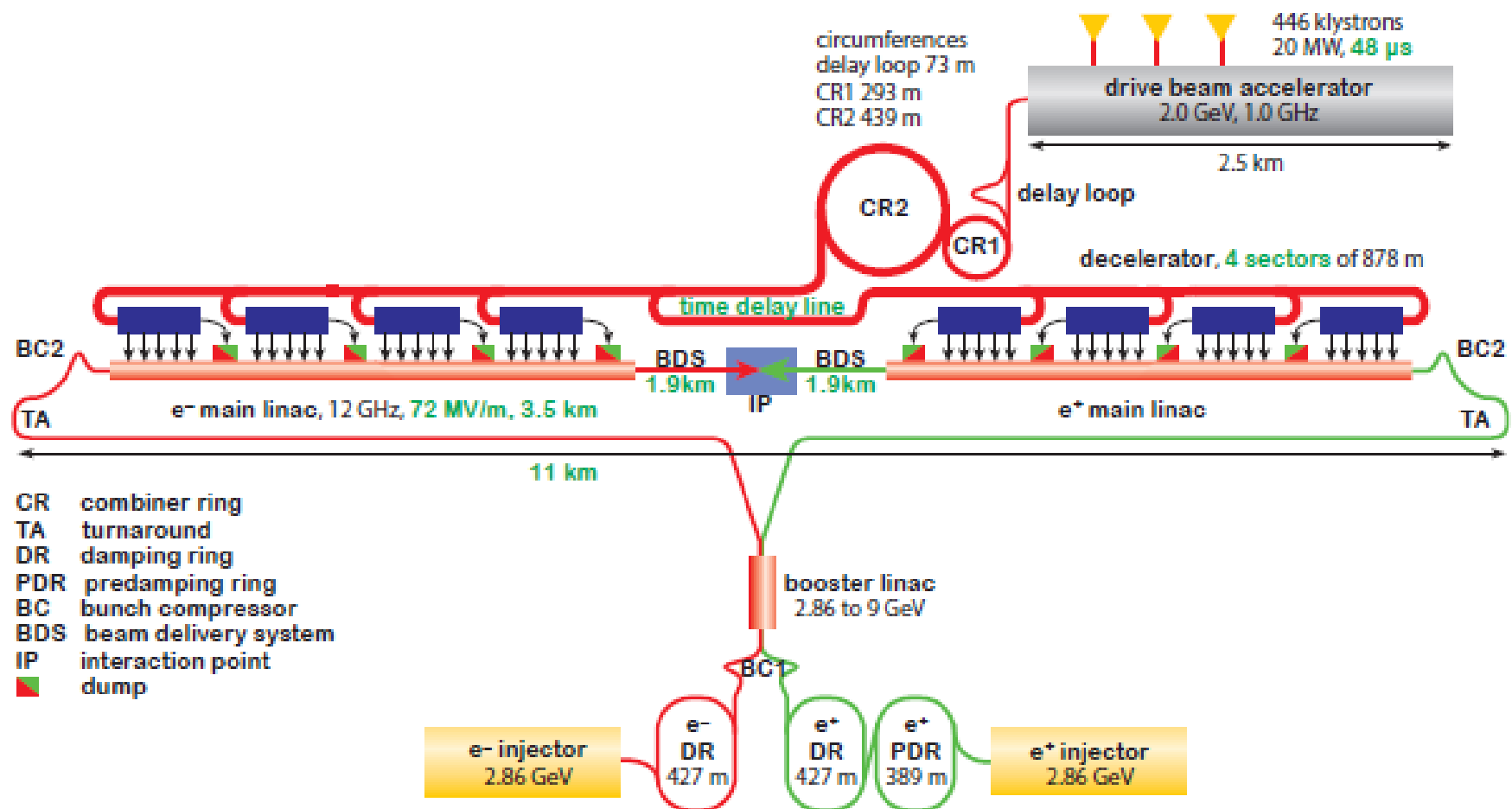

- CR combiner ring
- TA turnaround
- DR damping ring
- PDR predamping ring
- BC bunch compressor
- BDS beam delivery system
- IP interaction point
- █ dump

Legend

— CERN existing LHC

Potential underground siting :

●●●● CLIC 380 GeV

●●●● CLIC 1.5 TeV

●●●● CLIC 3 TeV

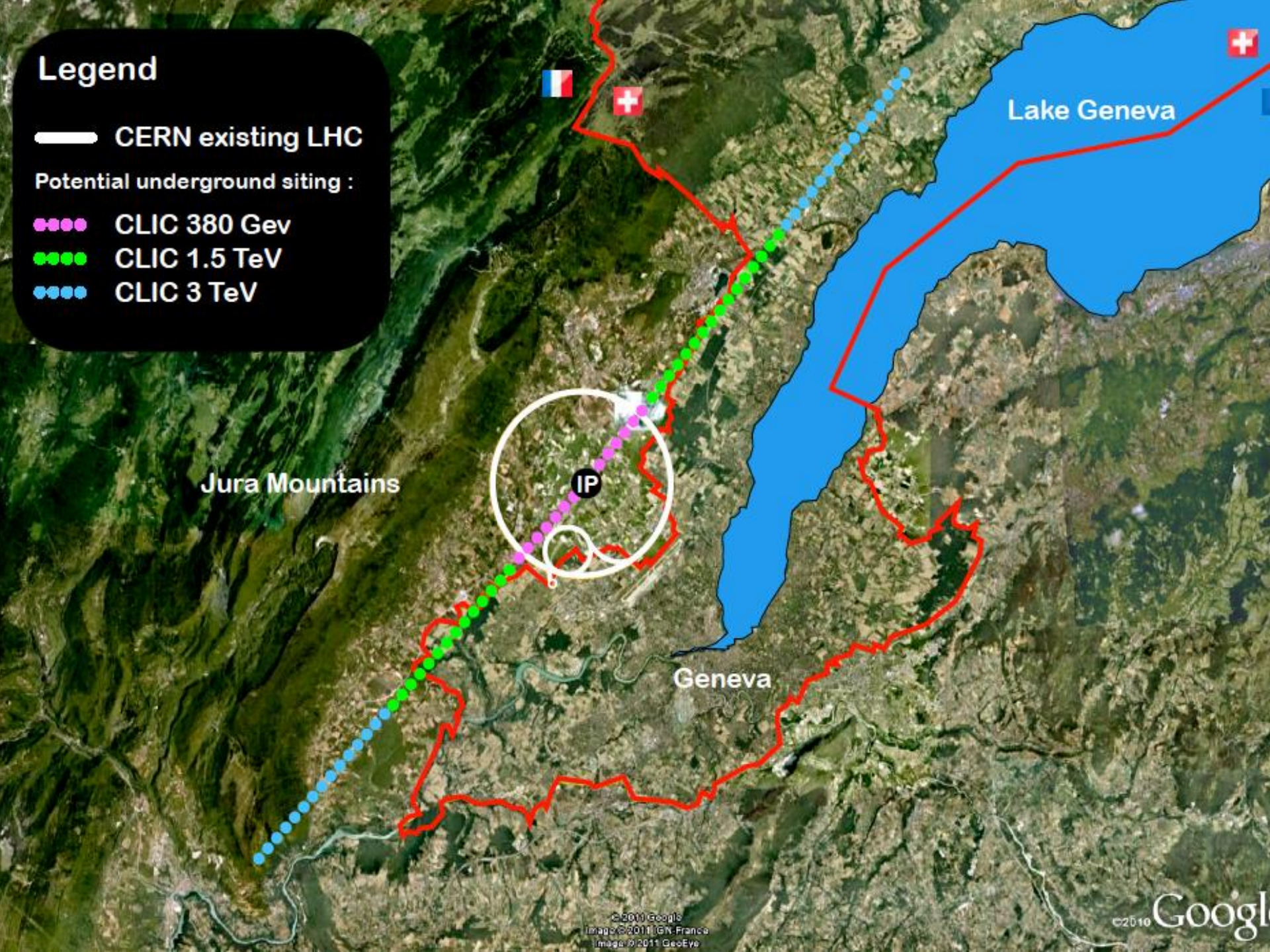

Jura Mountains

IP

Geneva

Lake Geneva

Updated CLIC run model

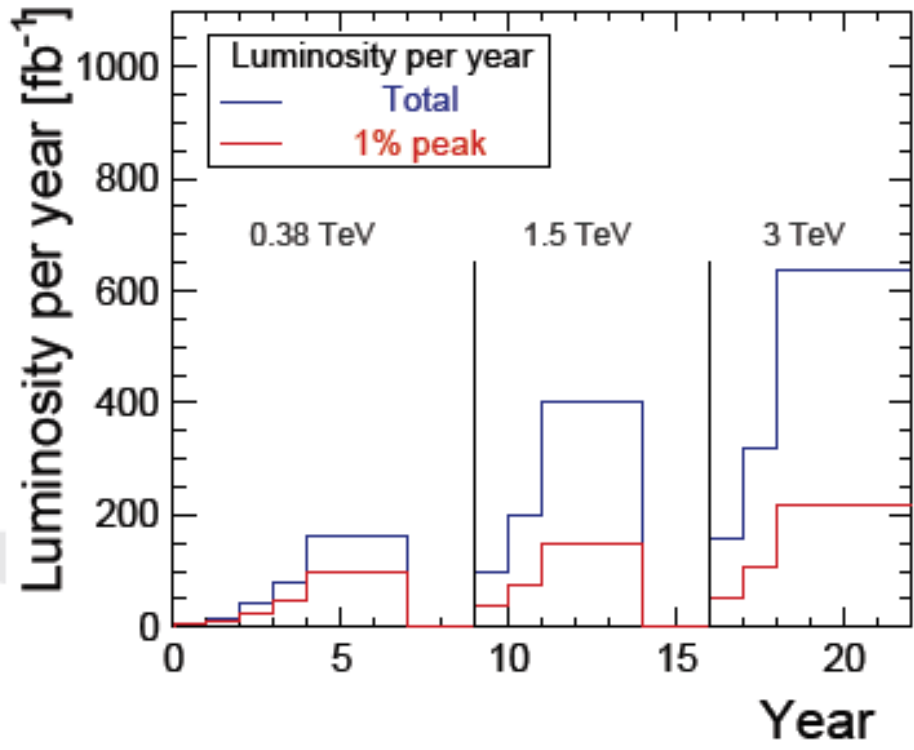

Stage	\sqrt{s} (GeV)	\mathcal{L}_{int} (fb ⁻¹)
1	380	500
	350	100
2	1500	1500
3	3000	3000



Preliminary cost estimate (380GeV)

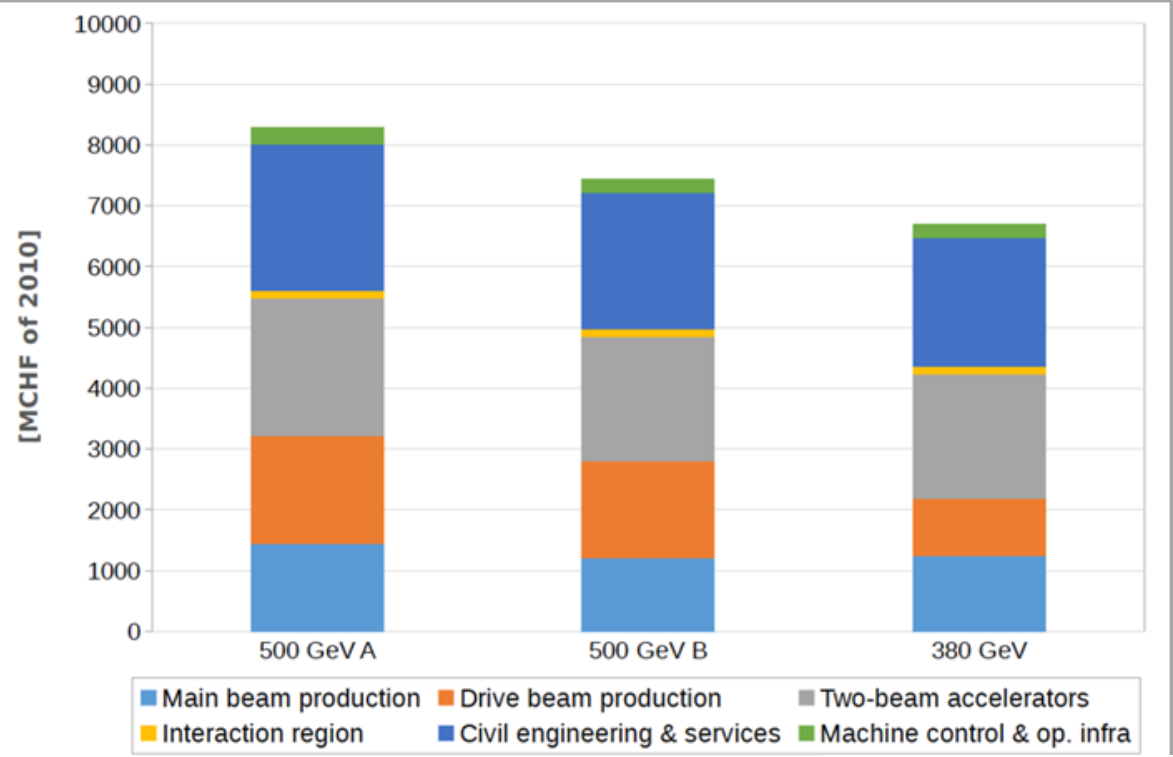

For CDR 2012 WBS cost basis

Optimised structures, beam parameters and RF system

Some costs scaled from 500 GeV

Further optimisation ongoing

Table 11: Value estimate of CLIC at 380 GeV centre-of-mass energy.

	Value [MCHF of December 2010]
Main beam production	1245
Drive beam production	974
Two-beam accelerators	2038
Interaction region	132
Civil engineering & services	2112
Accelerator control & operational infrastructure	216
Total	6690

Klystron version (380 GeV)

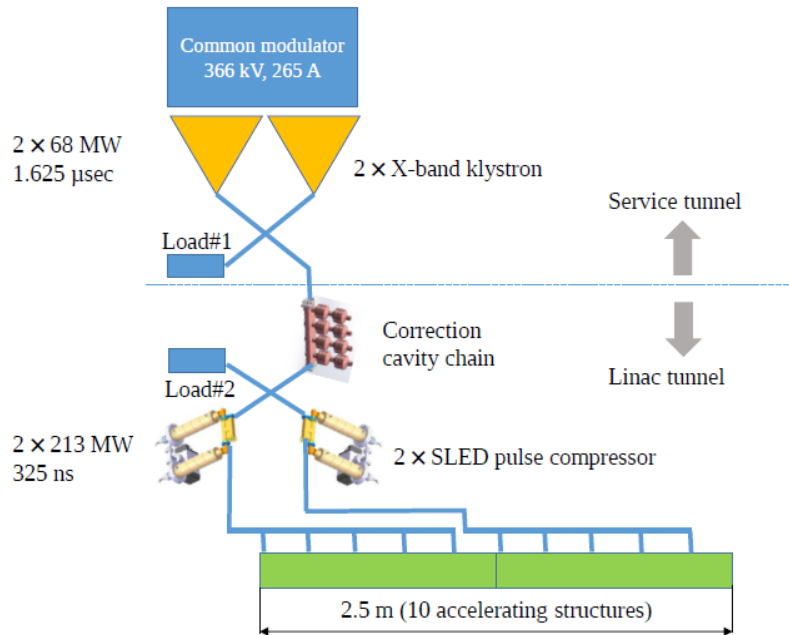

Klystron version (380 GeV)

First look at costs – preliminary

High-efficiency klystron work very promising – not yet included

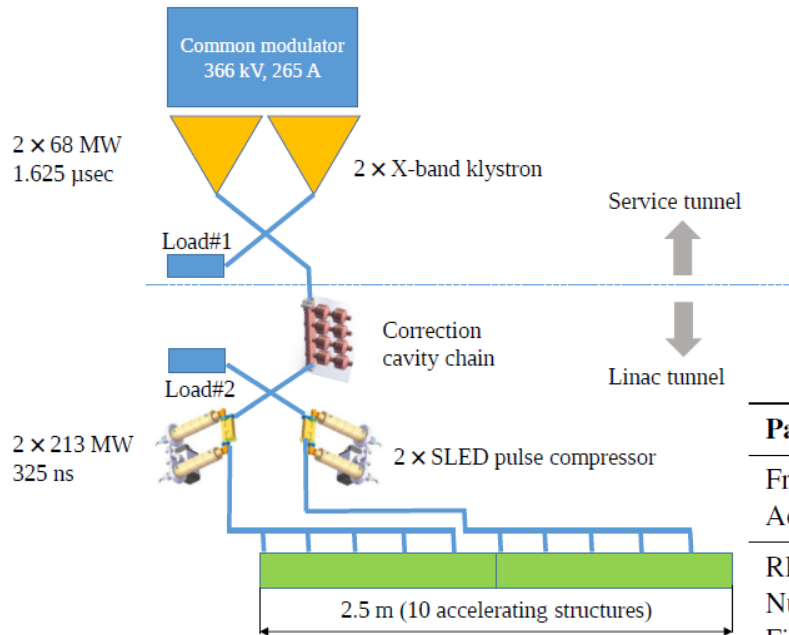

Table 12: The parameters for the structure designs that are detailed in the text.

Parameter	Symbol	Unit	DB	K	DB244	K244
Frequency	f	GHz	12	12	12	12
Acceleration gradient	G	MV/m	72.5	75	72	79
RF phase advance per cell	$\Delta\phi$	$^\circ$	120	120	120	120
Number of cells	N_c		36	28	33	26
First iris radius / RF wavelength	a_1/λ		0.1525	0.145	0.1625	0.15
Last iris radius / RF wavelength	a_2/λ		0.0875	0.09	0.104	0.1044
First iris thickness / cell length	d_1/L_c		0.297	0.25	0.303	0.28
Last iris thickness / cell length	d_2/L_c		0.11	0.134	0.172	0.17
Number of particles per bunch	N	10^9	3.98	3.87	5.2	4.88
Number of bunches per train	n_b		454	485	352	366
Pulse length	τ_{RF}	ns	321	325	244	244
Peak input power into the structure	P_{in}	MW	50.9	42.5	59.5	54.3
Cost difference (w. drive beam)	$\Delta C_{w, DB}$	MCHF	-50	(20)	0	(20)
Cost difference (w. klystrons)	$\Delta C_{w, K}$	MCHF	(120)	50	(330)	240

Klystron version (380 GeV)

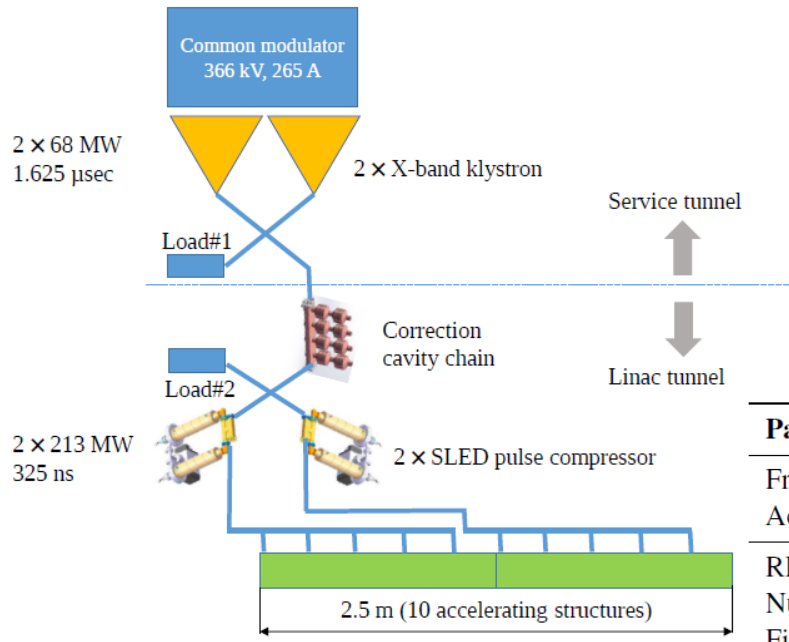

Table 12: The parameters for the structure designs that are detailed in the text.

Parameter	Symbol	Unit	DB	K	DB244	K244
Frequency	f	GHz	12	12	12	12
Acceleration gradient	G	MV/m	72.5	75	72	79
RF phase advance per cell	$\Delta\phi$	$^\circ$	120	120	120	120
Number of cells	N_c		36	28	33	26
First iris radius / RF wavelength	a_1/λ		0.1525	0.145	0.1625	0.15
Last iris radius / RF wavelength	a_2/λ		0.0875	0.09	0.104	0.1044
First iris thickness / cell length	d_1/L_c		0.297	0.25	0.303	0.28
Last iris thickness / cell length	d_2/L_c		0.11	0.134	0.172	0.17
Number of particles per bunch	N	10^9	3.98	3.87	5.2	4.88
Number of bunches per train	n_b		454	485	352	366
Pulse length	τ_{RF}	ns	321	325	244	244
Peak input power into the structure	P_{in}	MW	50.9	42.5	59.5	54.3
Cost difference (w. drive beam)	$\Delta C_{w,DB}$	MCHF	-50	(20)	0	(20)
Cost difference (w. klystrons)	$\Delta C_{w,K}$	MCHF	(120)	50	(330)	240

Costings relative to drive-beam version may be lower ~ 5%



AC power (1.5 TeV)

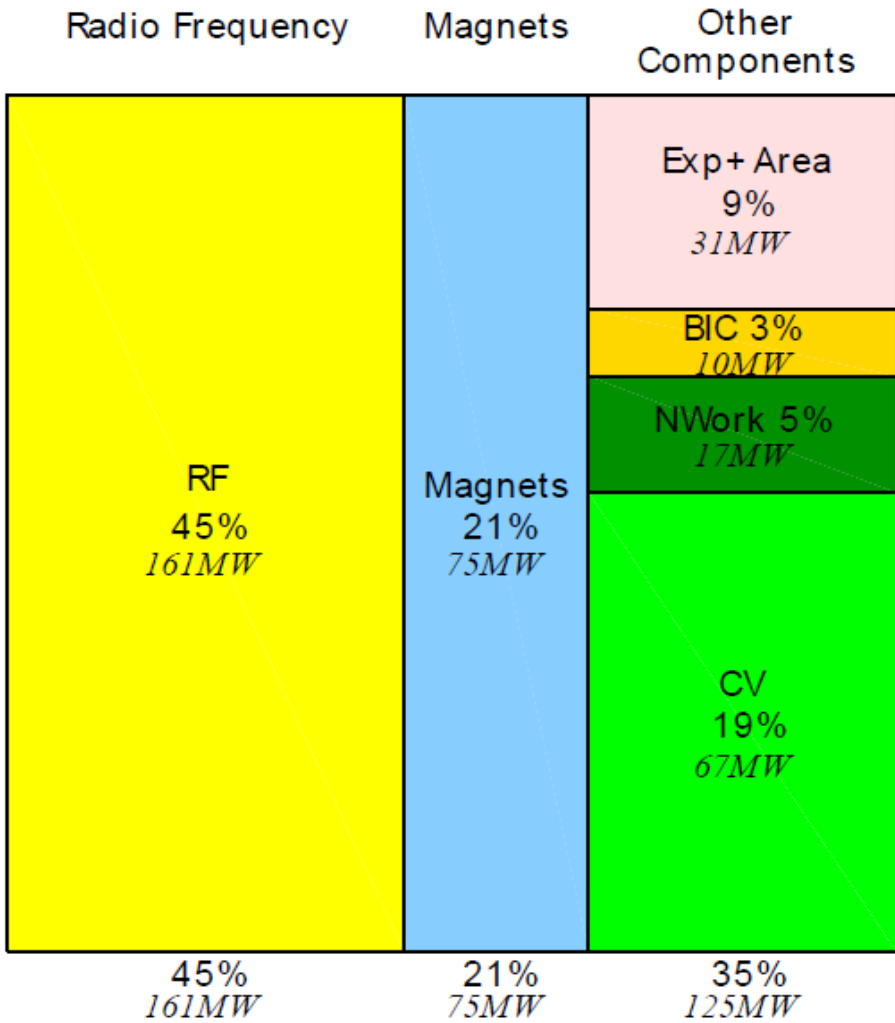

Klystron/modulator efficiencies

ECFA- Linear Collider Workshop 2016



CLIC Multi-beam (6/10 beams) pulsed klystron power balanced diagram.



Thales H1803

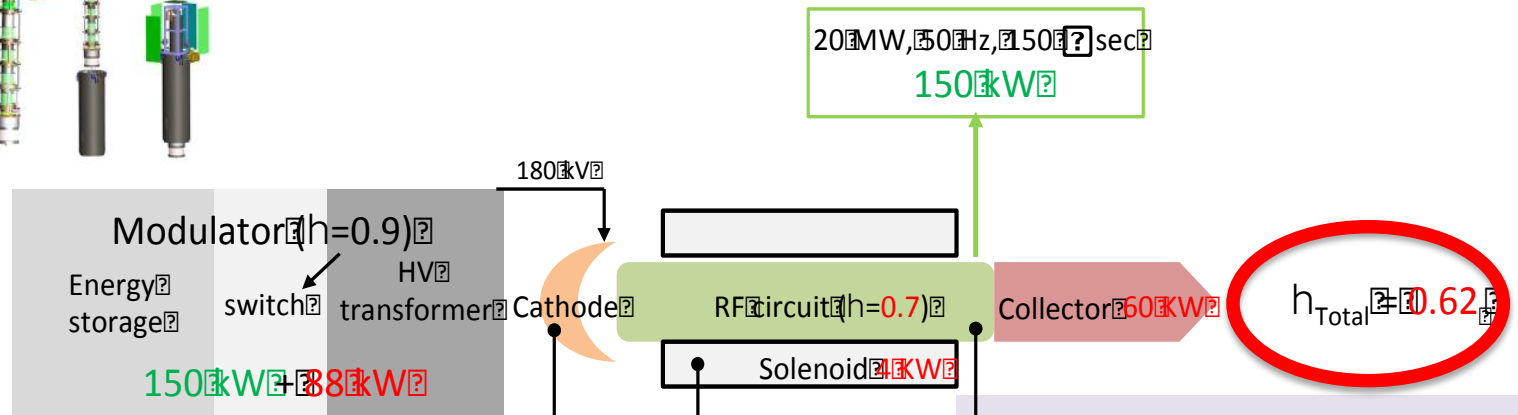

Can we do better?

- Lower (<60kV) voltage:
- 10 mini-cathodes
 - No dil tank (cost)
 - Shorter tube (cost)
 - Faster switching (efficiency/cost)

- Gated mini-cathode:
- No switches (cost)
 - Modulator efficiency ≈ 1.0
 - (+) Improved stability

- Permanent Magnets:
- No power consumption
 - Potential cost reduction
 - Vs. Solenoid:
 - More expensive solution

- New klystron RF circuit ($h=0.9$)
- (+) Reduced Collector dissipation (16 kW)

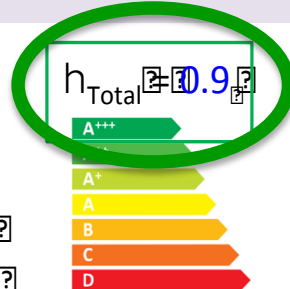

CLIC requires about 300 klystrons.
Successful implementation of all the actions above could save 60 MW and reduce the power plant cost by 15%.

Magnet Assessment – use PMs wherever possible

DRIVE BEAM

Type	Magnet type	Total	Effective Length [m]	H	V	Strength	Units	Min field	Max field	Rel Field Accuracy	Higher Harmonics per magnet [Tm]	[kW]	total [MW]
DBQ	Quadrupole	41400	0.194	26	26	62.78T/m		10%	120%	1E-03	1.0E-04	0.5	17.0
MBTA	Dipole	576	1.5	40	40	1.6T		10%	100%	1E-03	1.0E-04	21.6	12.4
MBCOTA	Dipole	1872	0.2	40	40	0.07T		-100%	100%	1E-03	1.0E-03	0.3	0.5
QTA	Quadrupole	1872	0.5	40	40	14T/m		10%	100%	1E-03	1.0E-04	2.0	3.7
SXTA	Sextupole	1152	0.2	40	40	85T/m ²		10%	100%	1E-03	1.0E-03	0.1	0.1

Potential saving of 29MW

MAIN BEAM

Type	Magnet type	Total	Effective Length [m]	H	V	Strength	Units	Min field	Max field	Rel Field Accuracy	Higher Harmonics per magnet [Tm]	[kW]	total [MW]
MB1	Dipole												
MB2	Dipole												
MB3	Dipole												
MBCO	Dipole	1											
Q1	Quadrupole	1											
SX	Sextupole												
SX2	Sextupole												
QLINAC	Quadrupole	1											
MBCO2	Dipole_CO												
Q4	Quadrupole												

DAMPING AND PRE-DAMPING RINGS

Type	Magnet type	Total	Effective Length [m]	H	V	Strength	Units	Min field	Max field	Rel Field Accuracy	Higher Harmonics per magnet [Tm]	[kW]	total [MW]
D1.7	Dipole	76	1.3	160	80	1.7T		75%	100%	5E-04	37.5	2.9	
Q30L04	Quadrupole	408	0.4	80	80	30T/m		20%	100%	5E-04	11.4	4.7	
Q30L02	Quadrupole	408	0.2	80	80	30T/m		20%	100%	5E-04	8.2	3.3	
S300	Sextupole	204	0.3	80	80	300T/m ²		0%	100%	5E-04	1.2	0.2	
ST0.3	Steerer	312	0.15	80	80	0.3T		-100%	100%	5E-04	1.5	0.5	
SkQ5	Skew Quad	76	0.15	80	80	5T/m		-100%	100%	5E-04	0.8	0.1	
CFM	Combined Dipole/Quad	204	0.43	100	20	1.4T		75%	125%	5E-04	2.4	0.5	
D1.7Q10.5				0	0	10.5T/m						0.0	
Q75	Quadrupole	1004	0.2	20	20	75T/m		20%	100%	5E-04	0.8	0.8	
S5000	Sextupole	576	0.15	20	20	5000T/m ²		0%	100%	5E-04	0.2	0.1	
ST0.4	Steerer	712	0.15	20	20	0.4T		-100%	100%	5E-04	0.4	0.3	
SkQ20	Skew Quad	96	0.15	20	20	20T/m		-100%	100%	5E-04	0.2	0.0	



Adjustable-field PM prototypes

High Energy Quad



Low Energy Quad



Dipole design

Sideplate & Nut Plate Assembly

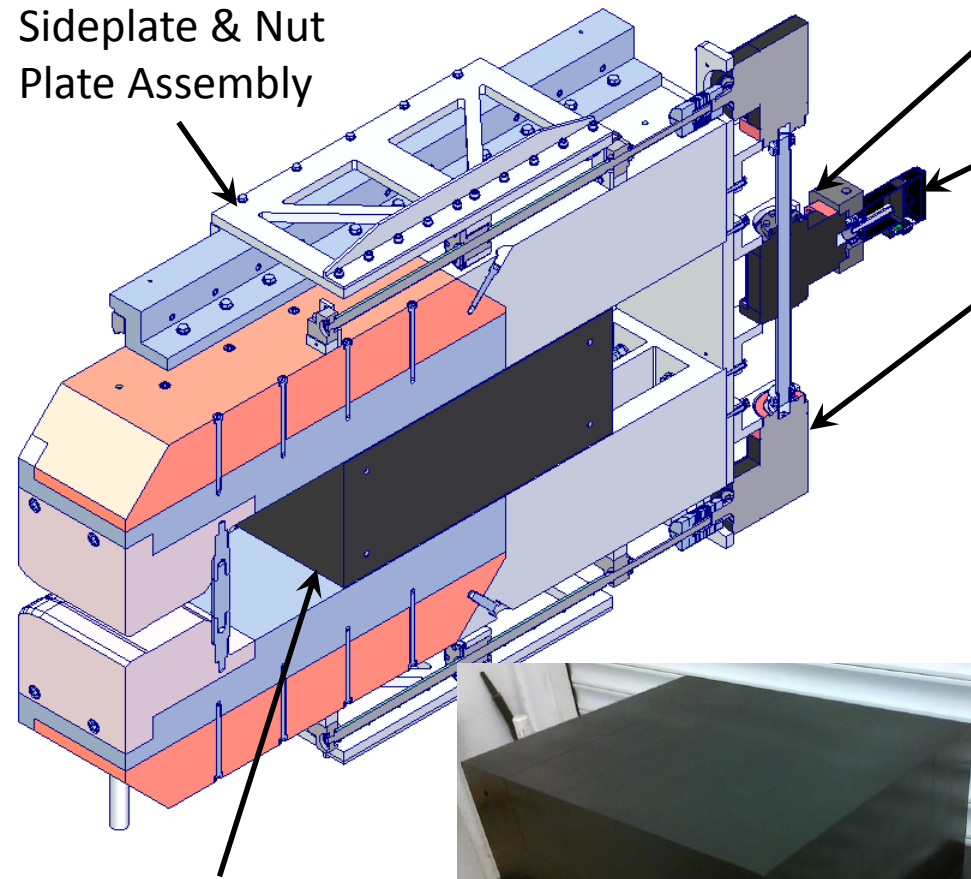

Permanent Magnet Base





Cost and power updates foreseen



A WBS based bottom up costing and power estimate, for drive-beam and klystron based machines, will be done for the Project Plan in ~2019.

Power and cost related studies that are expected to make significant changes:

Action (X = significant impact expected)	Cost	Power/Energy	Comments
Structure/parameters optimisation, minor other changes	X	X	Ok for now, 380 GeV, $1.5 \cdot 10^{34}$
Further possibility: lower inst. luminosity or initial energy (250 GeV)	X	X	Integrated lum. goal can be maintained
Known corrections needed for injectors and Cooling/Ventilation	X	X	Combination of over-estimates and average vs max in CDR
Structure manufacturing	X		Optimise, remove steps, halves
High eff. Klystrons and RF distribution	X	X	Technical studies where gains can be large
Magnets	?	X	Technical studies
Running scenario (daily, weekly, yearly)		X (energy, cost)	Take advantage of demand changes
Commercial studies, currencies and reference costing date	X	X	Examples: klystrons, CHF, CLIC and FCC will use similar convention



CLIC accelerating structure



Outside

11.994 GHz X-band
100 MV/m
Input power \approx 50 MW
Pulse length \approx 200 ns
Repetition rate 50 Hz

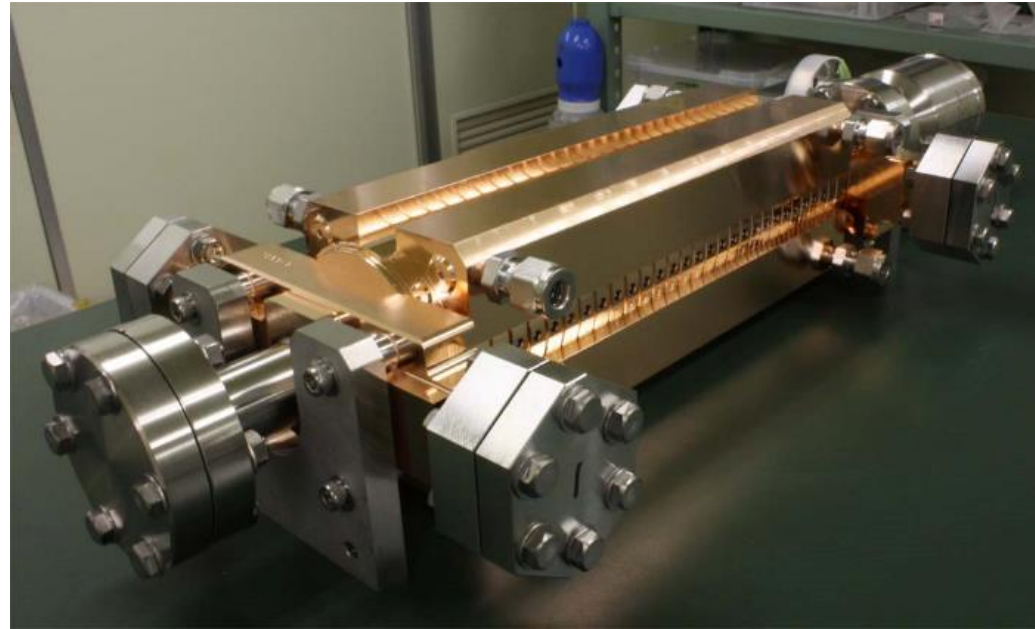

HOM damping
waveguide

Inside

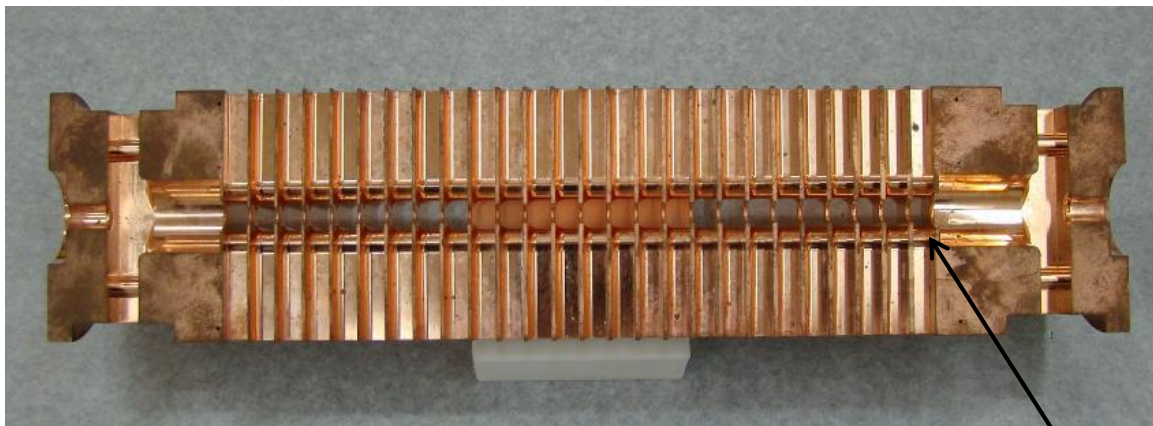

25 cm

CLIC Project Review, 1 March 2016

Micron-precision disk

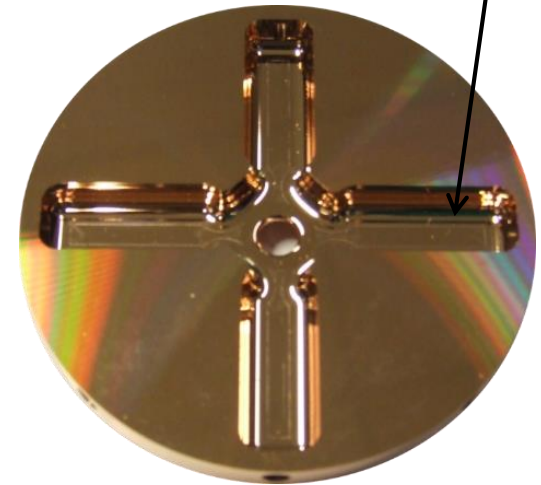

6 mm diameter
beam aperture

Walter Wuensch, CERN

AS DISC

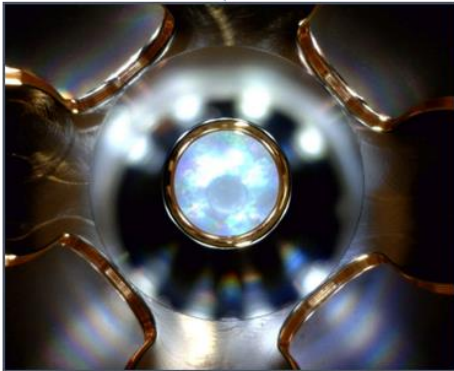
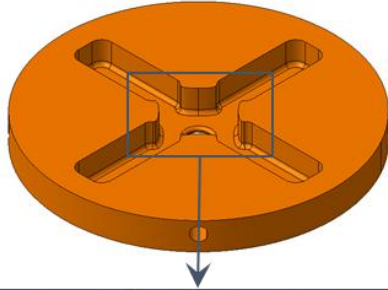

Cell shape accuracy - 0.004 mm
Flatness - 0.001 mm
Surface roughness - Ra 0.025
µm

Commercial suppliers:

- 4 qualified companies for UP machining;
- Single-crystal diamond tool required.

AS DISC STACK BONDING

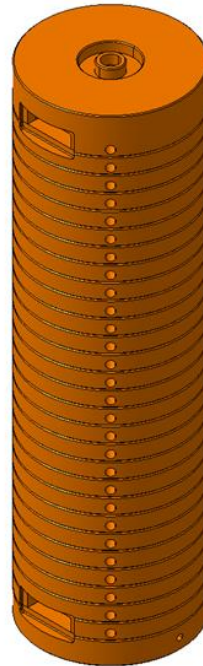

AS ASSEMBLY

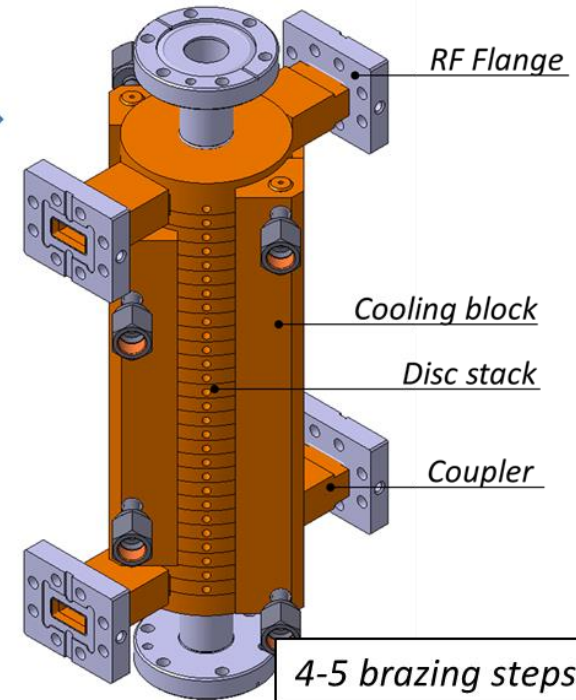

REQUIREMENTS:

- Alignment
- Special tooling
- Clean environment

Suppliers:

- 3 qualified companies for brazing/bonding operations, supervision by CERN;
- Collaborators.

CLIC accelerating structure



11.994
100 M
Input
Pulse
Repet

Inside



damping
guide

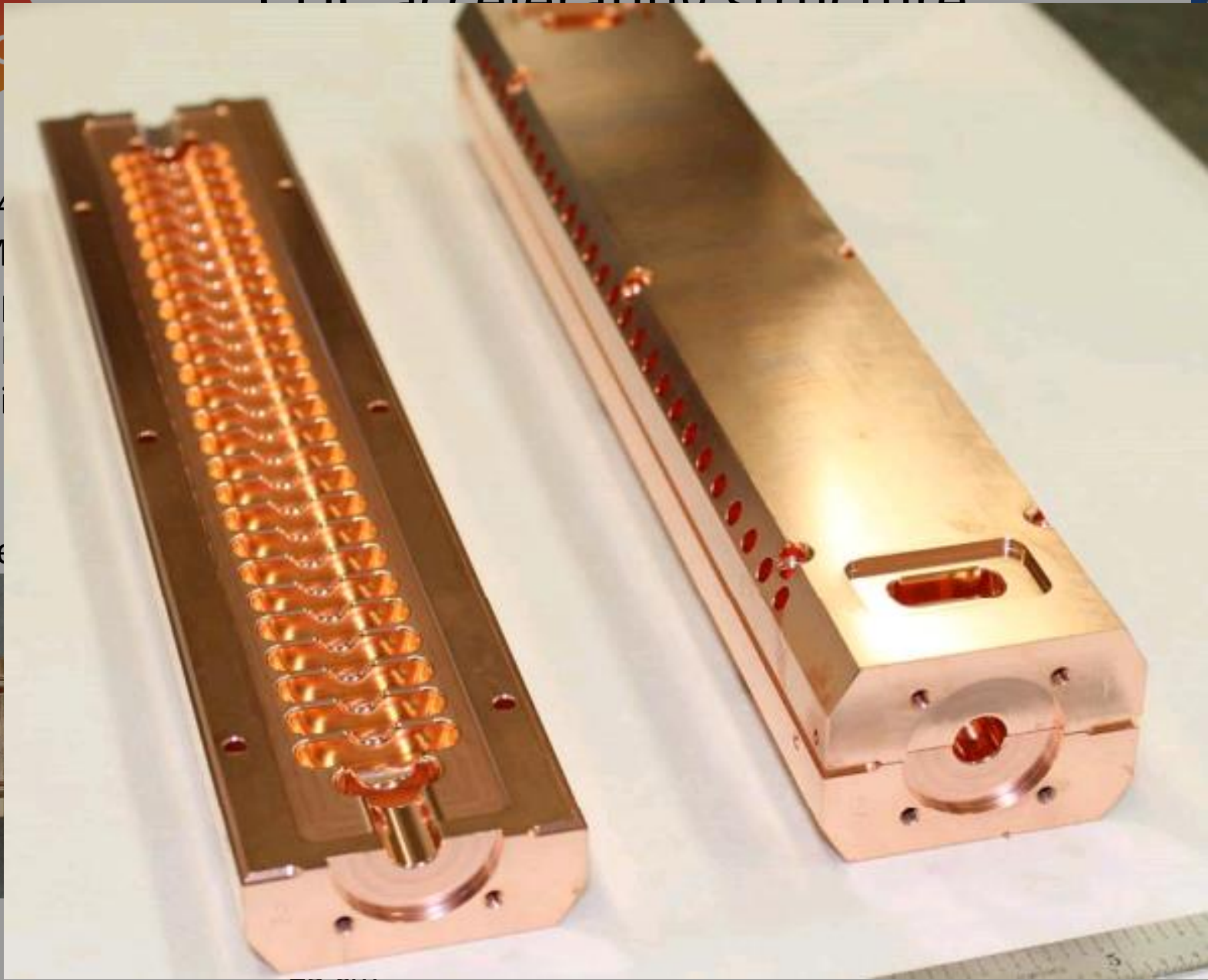
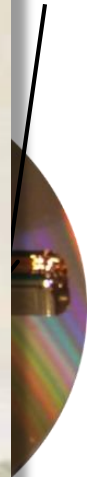

European National/Institute XFEL Ambitions

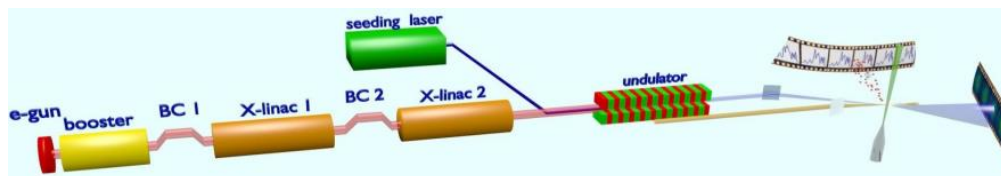

University of Groningen: FEL-NL

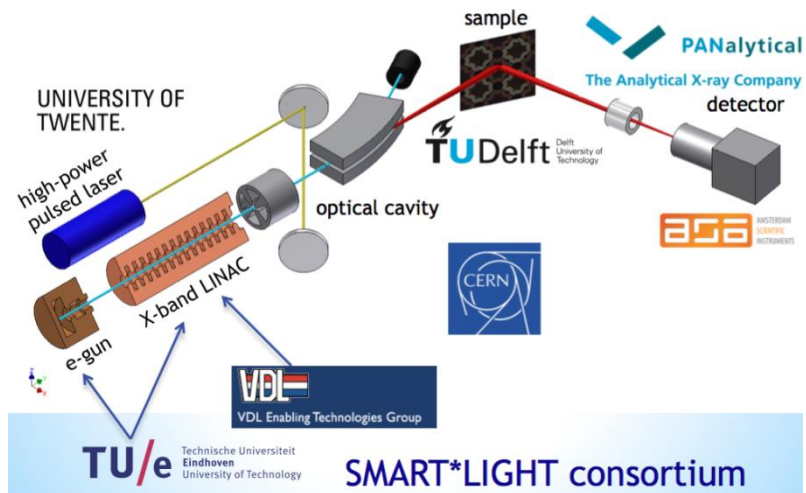

Eindhoven University of Technology: Smart*Light

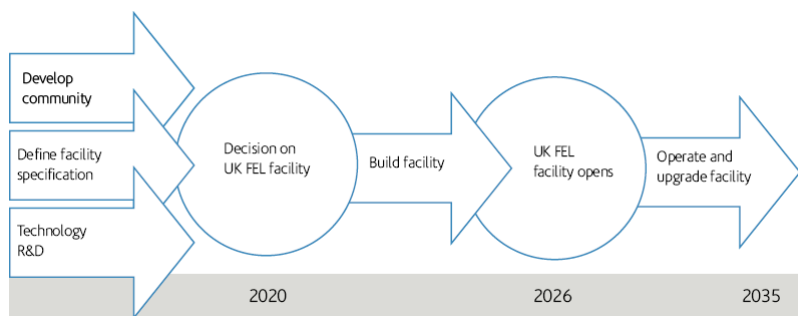

UK FEL Strategy & Timeline towards Hard X-ray FEL

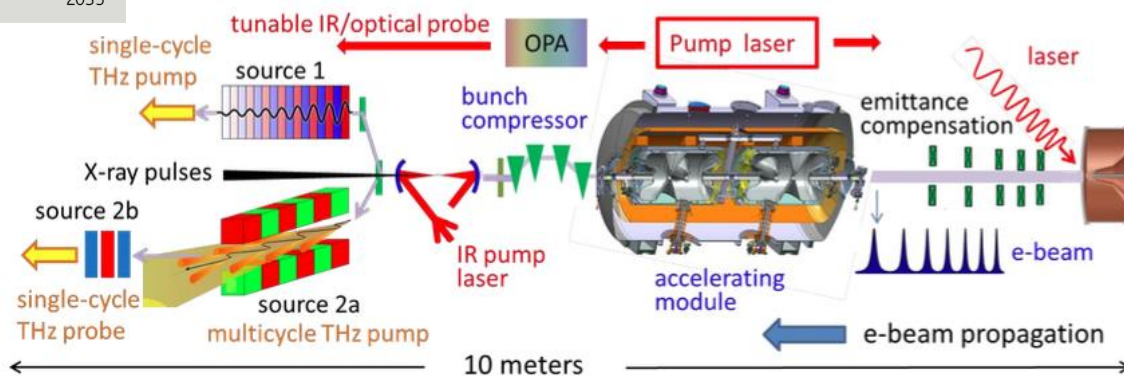

Stockholm/Uppsala FEL centre: X-ray & THz radiation

CompactLight – EU Horizon2020 proposal

1	Coordinator	Elettra-Sincrotrone Trieste S.c.p.A.	Italy
2		CERN-European Organization for Nuclear Research	International
3		STFC-Daresbury Laboratory	UK
4		SINAP, Chinese Academy of Sciences	China
5		Institute of Accelerating Systems and Applications	Greece
6		Uppsala University	Sweden
7		The University of Melbourne	Australia
8		Australian Nuclear Science and Technology Organisation	Australia
9		Ankara University Institute of Accelerator Technologies	Turkey
10		Lancaster University	UK
11		VDL Enabling Technology Group Eindhoven BV	Netherlands
12		Technische Universiteit Eindhoven	Netherlands
13		Istituto Nazionale di Fisica Nucleare	Italy
14		Kyma S.r.l.	Italy
15		University of Rome "La Sapienza"	Italy
16		Italian National Agency for New Technologies, Energy and Sustainable Economic Development, ENEA	Italy
17		Consortio para la Construcción Equipamiento y Explotación del Laboratorio de Luz Síncrotron	Spain
18		Centre National de la Recherche Scientifique, CNRS	France
19		Karlsruher Institut für Technologie	Germany
20		Paul Scherrer Institut PSI	Switzerland
21		Agencia Estatal Consejo Superior de Investigaciones Científicas	Spain
22		University of Helsinki Helsinki Institute of Physics	Finland
23		Pulsar Physics	Netherlands
24		VU University Amsterdam	Netherlands
	Third Parties	Third party's organisation name	Country
		Universitetet i Oslo University of Oslo	Norway
		Advanced Research Center for Nanolithography (URU of VU)	Netherlands

Italy 5
 Neth. 4+1
 UK 2
 Spain 2
 Austr. 2
 China 1
 Greece 1
 Sweden 1
 Turkey 1
 France 1
 Germany 1
 Switz. 1
 Finland 1
 Norway 0+1
 Internat. 1

submitted
 March 29th!

CTF3

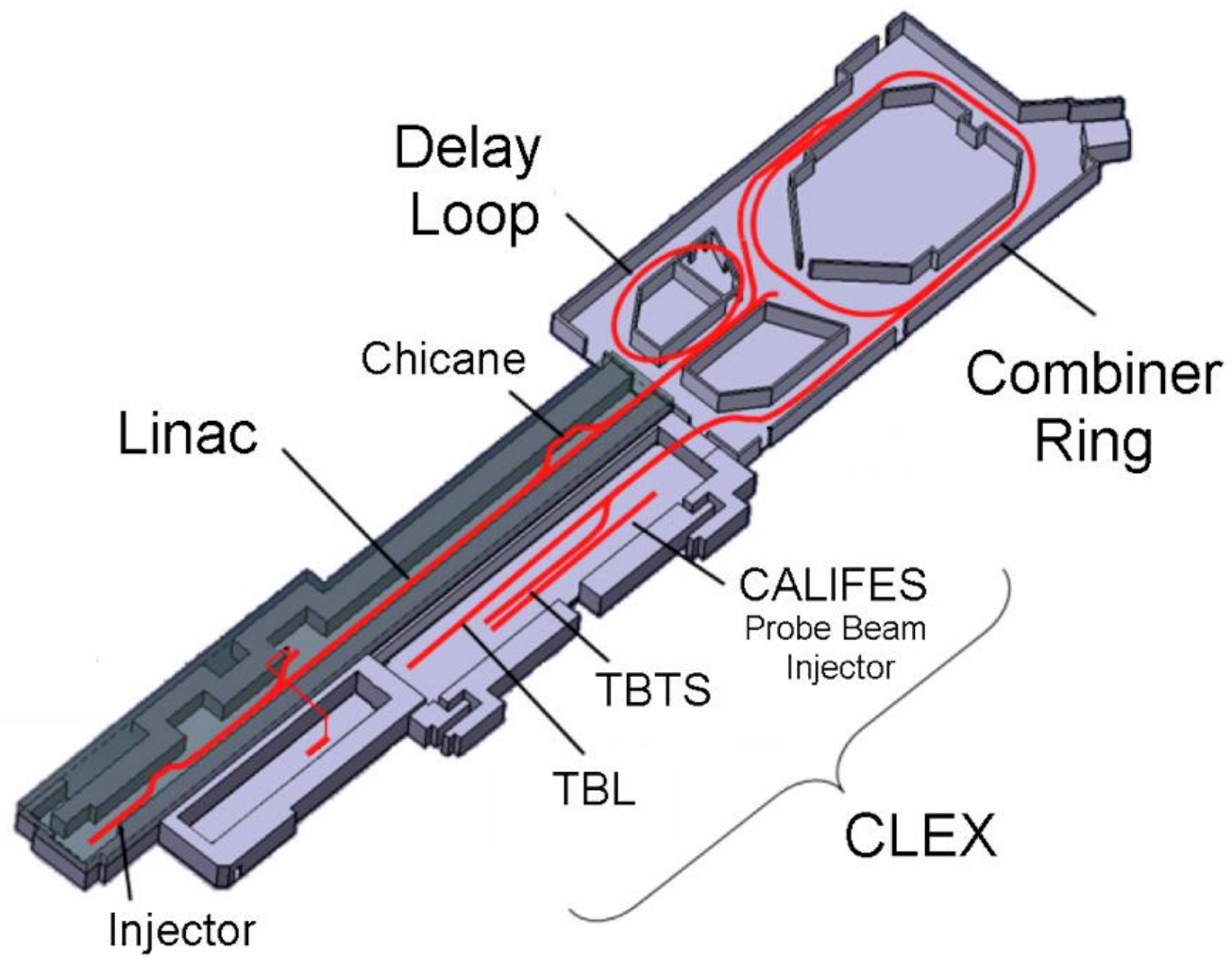

CTF3 Experimental Program 2016

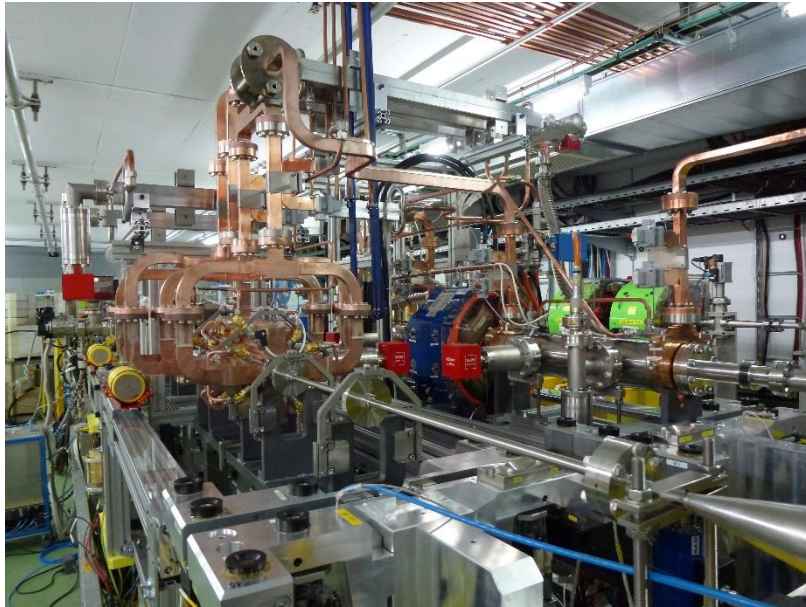

CLIC two-beam module tests

- Power production, stability + control of RF profile (beam loading compensation)
- RF phase/amplitude drifts along TBL, PETS switching at full power
- Alignment tests

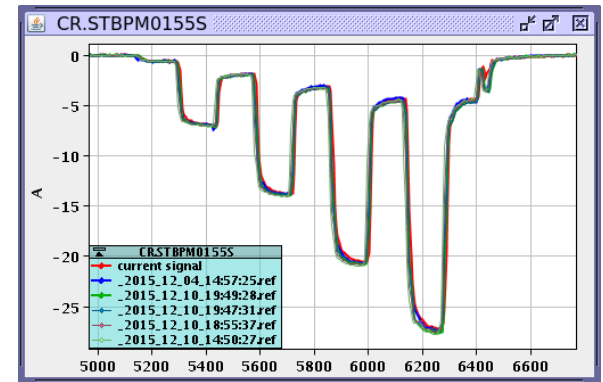

Drive Beam

- Dispersion free-steering, dispersion matching, orbit control, chromatic corrections, emittance, stability
- Beam deceleration + optics check in TBL

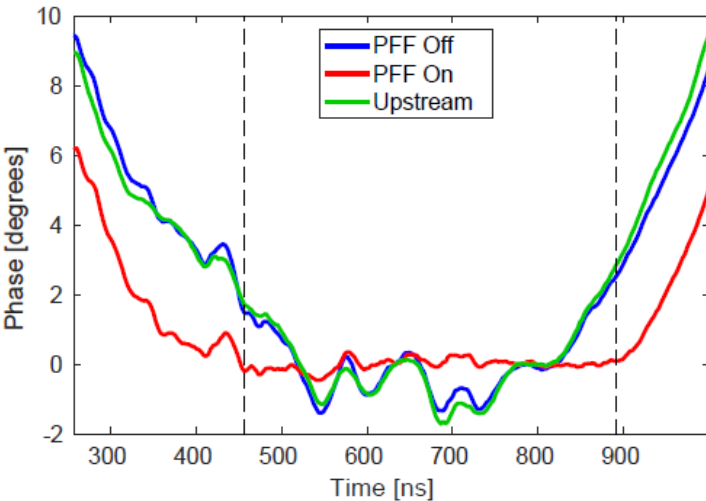

Drive-beam phase feed-forward tests

- Increase reproducibility
- Demonstrate factor ~ 10 jitter reduction

Ongoing instrumentation tests

- Wake-Field Monitors
- Main and Drive beam BPMs ...

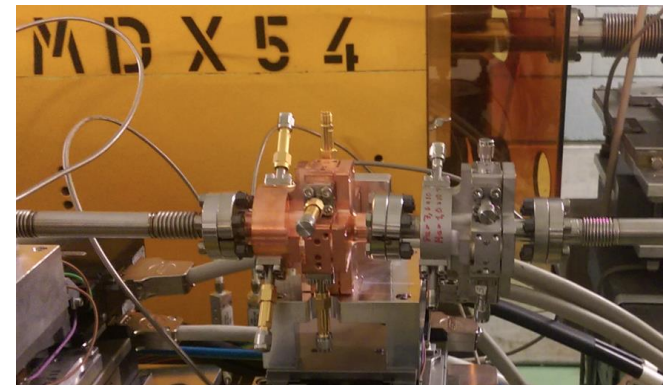

CALIFES → 'CLEAR' CERN Linear Electron Accelerator for Research

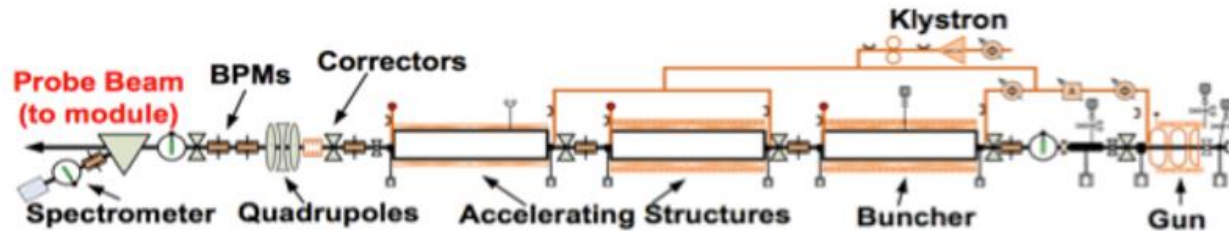

Figure 1: The current CALIFES beam line. The length of the facility (as shown) is ~20m.



Beam parameter (end of linac)	Value range
Energy	80 - 220 MeV
Bunch charge	0.01 - 1.5 nC
Normalized emittances	2 μm in both planes
Bunch length	300 μm - 1.2 mm
Relative energy spread	1 %
Repetition rate	1 - 5 Hz
Number of micro-bunches in train	Selectable between 1 and >100
Micro-bunch spacing	1.5 GHz

Table 1: CALIFES parameters.

ATF/ATF2 (KEK)

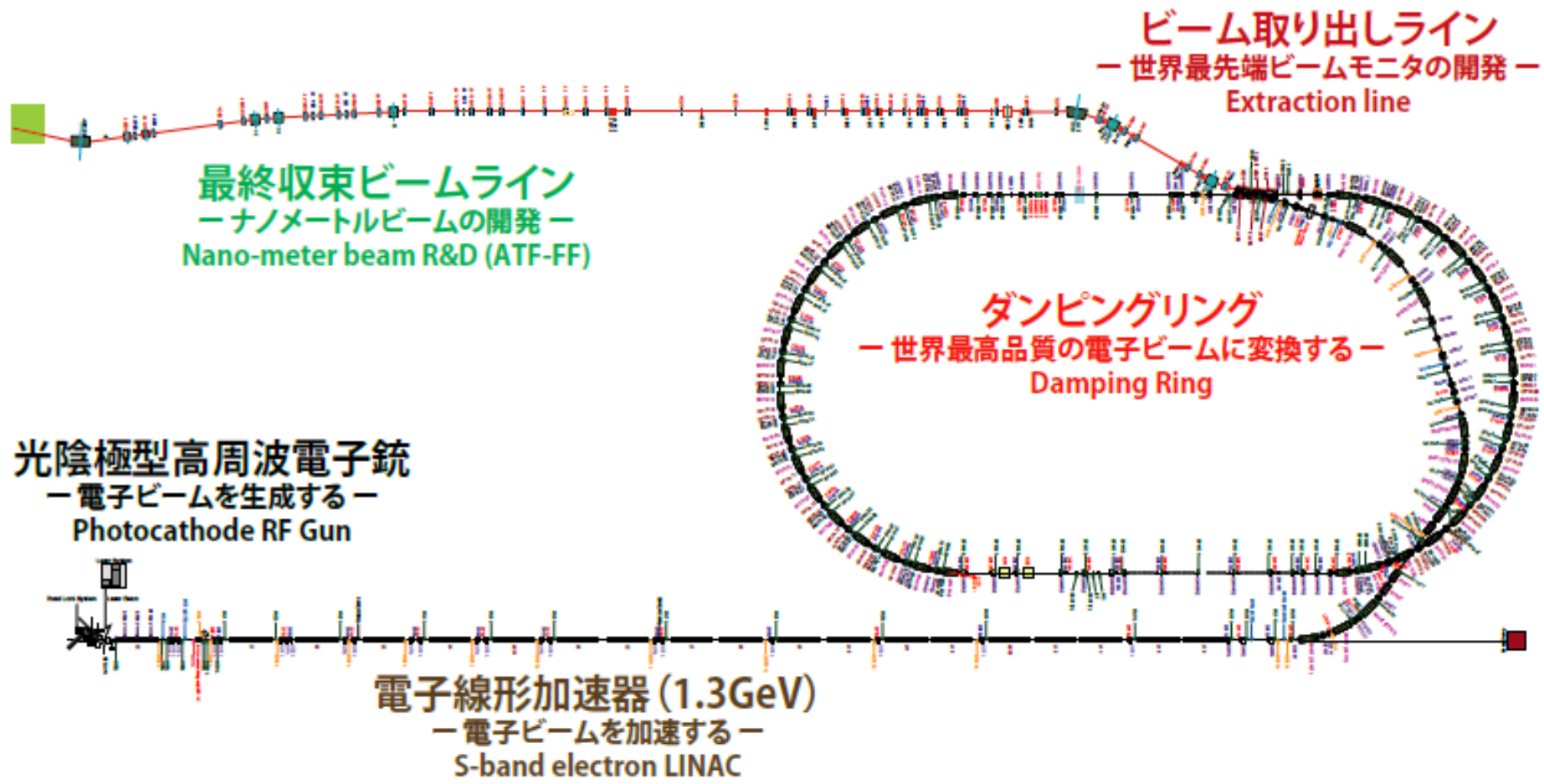



CLIC + ATF/ATF2

Demonstration of nanometer-scale beam (~41nm achieved)

Beam stabilisation at nanometre level

Also:

Beam tuning techniques

Beam jitter characterisation and amelioration

Beam feedback + feed-forward

Magnet development (hybrid QD0, PM octupoles)

Beam instrumentation: BPMs, transverse beam size ...

DR extraction kicker tests ...

CLIC + ATF/ATF2

Demonstration of nanometer-scale beam (~41nm achieved)

Beam stabilisation at nanometre level

Also:

Beam tuning techniques

Beam jitter characterisation and amelioration

Beam feedback + feed-forward

Magnet development (hybrid QD0, PM octupoles)

Beam instrumentation: BPMs, transverse beam size ...

IR extraction kicker tests ...

Nobuhiro Terunuma awarded Orito-Shuji Prize



Outlook → European Strategy

Aim to:

- **Present CLIC as a credible post-LHC option for CERN**
- **Provide optimized, staged approach starting at 380 GeV, with costs and power not excessive compared with LHC, and leading to 3 TeV**
- **Upgrades in 2-3 stages over 20-30 year horizon**
- **Maintain flexibility and align with LHC physics outcomes**



CLIC roadmap

2013 - 2019 Development Phase

Development of a Project Plan for a staged CLIC implementation in line with LHC results; technical developments with industry, performance studies for accelerator parts and systems, detector technology demonstrators

2020 - 2025 Preparation Phase

Finalisation of implementation parameters, preparation for industrial procurement, Drive Beam Facility and other system verifications, Technical Proposal of the experiment, site authorisation

2026 - 2034 Construction Phase

Construction of the first CLIC accelerator stage compatible with implementation of further stages; construction of the experiment; hardware commissioning



2019 - 2020 Decisions

Update of the European Strategy for Particle Physics; decision towards a next CERN project at the energy frontier (e.g. CLIC, FCC)

2025 Construction Start

Ready for construction; start of excavations

2035 First Beams

Getting ready for data taking by the time the LHC programme reaches completion



Compact Linear Collider



Outlook → European Strategy

Key deliverables:

Project plan: physics, machine parameters, cost, power, site, staging, construction schedule, summary of main tech. issues, prep. phase (2020-2025) summary, detector studies

Preparation-phase plan: critical parameters, status and next steps - what is needed before project construction, strategy, risks and how to address them



Compact Linear Collider

CLIC Workshop 2017

6-10 March 2017

CERN

Europe/Zurich timezone

There is a [live webcast](#) for this event.

Overview

Timetable

Registration

Participant List

The **CLIC workshop 2017** covers Accelerator as well as the Detector and Physics studies, with their present activities and programme for the coming years.

For the Accelerator studies, the workshop spans over 5 days: 6th - 10th of March.

For CLICdp, the workshop is scheduled from Tuesday afternoon 7th to lunchtime on Friday 10th.

Programme

Common parts:

CERN Courier article

“CLIC steps up to the TeV challenge”
by Philipp Roloff and Daniel Schulte
(November 2016)

<http://cerncourier.com/cws/article/cern/66567>





Backup slides

Current rebaselined parameters

Table 8: Parameters for the CLIC energy stages. The power consumptions for the 1.5 and 3 TeV stages are from the CDR; depending on the details of the upgrade they can change at the percent level.

Parameter	Symbol	Unit	Stage 1	Stage 2	Stage 3
Centre-of-mass energy	\sqrt{s}	GeV	380	1500	3000
Repetition frequency	f_{rep}	Hz	50	50	50
Number of bunches per train	n_b		352	312	312
Bunch separation	Δt	ns	0.5	0.5	0.5
Pulse length	τ_{pulse}	ns	244	244	244
Accelerating gradient	G	MV/m	72	72/100	72/100
Total luminosity	\mathcal{L}	$10^{34} \text{ cm}^{-2} \text{ s}^{-1}$	1.5	3.7	5.9
Luminosity above 99% of \sqrt{s}	$\mathcal{L}_{0.01}$	$10^{34} \text{ cm}^{-2} \text{ s}^{-1}$	0.9	1.4	2
Main tunnel length		km	11.4	29.0	50.1
Charge per bunch	N	10^9	5.2	3.7	3.7
Bunch length	σ_z	μm	70	44	44
IP beam size	σ_x/σ_y	nm	149/2.9	$\sim 60/1.5$	$\sim 40/1$
Normalised emittance (end of linac)	ϵ_x/ϵ_y	nm	—	660/20	660/20
Normalised emittance	ϵ_x/ϵ_y	nm	950/30	—	—
Estimated power consumption	P_{wall}	MW	252	364	589

CERN	XBox-1 test stand	50 MW	Operational
	Xbox-2 test stand	50 MW	Operational
	XBox-3 test stand	4x6 MW	Commissioning
KEK	NEXTEF	2x50 MW	Operational, supported in part by CERN
SLAC	ASTA	50 MW	Operational, one structure test supported by CERN
	Design of high-efficiency X-band klystron	30 MW	Under discussion
Trieste	Linearizer for Fermi	50 MW	Operational
PSI	Linearizer for SwissFEL	50 MW	Operational
	Deflector for SwissFEL	50 MW	Planning
DESY	Deflector for FLASHforward	50 MW	Planning (note first two may share power unit)
	Deflector for FLASH2	50 MW	Planning
	Deflector for Sinbad	50 MW	Planning

Summary of X-band test stands at CERN:

- Xbox-1:** Operational. CPIS 50 MW Sus-klystron, Scandinoval Modulator, Rep Rate 50 Hz, Beam test capabilities. Previous tests: 2013 D24R05 (CTF2), 2013 D26CC-N1 (CTF2), 2014-15 D24 (Dogleg). Ongoing test: Aug 2015 D26CC-N1 (Dogleg).
- Xbox-2:** Operational. CPIS 50 MW Sus-klystron, Scandinoval Modulator, Rep Rate 50 Hz. Previous tests: 2014-15 CLIC crab cavity. Ongoing test: Sep 2015 D24 OPEN.
- Xbox-3:** Commissioning. 4x oshiba 1 MW Sus-klystron, 4x Scandinoval Modulators, Rep Rate 100 Hz. Previous tests: Medium power tests (Xbox-3A), 2015 D-printed waveguide, 2015 X-band RF valve. Major increase in testing capacity.

X-band test stands at KEK and SLAC

Nextef facilities at KEK:

- Operating at 25 MW, 75 MHz, Pulse length 200 ns.
- TSinghua University and SINAP have both ordered 50 MW X-band klystrons.

SLAC: CLIC Structure Conditioning Xbox II Architecture:

- Status: All computation functionality in place.
- Improved Conditioning Algorithm, Increased Pulse Length.
- Initiation of Controller.
- Operating at 25 MW, 75 MHz, Pulse length 200 ns.

Australia	Test stand	2x6 MW	Proposal, loan agreement from CERN
Eindhoven	Compact Compton source	6 MW	Proposal, request for loan from CERN
Uppsala	Test stand	50 MW	Proposal, request for loan of spare klystron from CERN
Tsinghua	Deflector for Compton source	50 MW	Ordered
	Linearizer for Compton source	6 MW	Planning
SINAP	Linearizer for soft X-ray FEL	6 MW	Ordered
	Deflectors for soft X-ray FEL	3x50 MW	Planning
Valencia	S-band test stand	2x10 MW	Under construction
STFC	Linearizer	6 MW	Under discussion
	Deflector	10 MW	Under discussion
	Accelerator	tbd	Under discussion

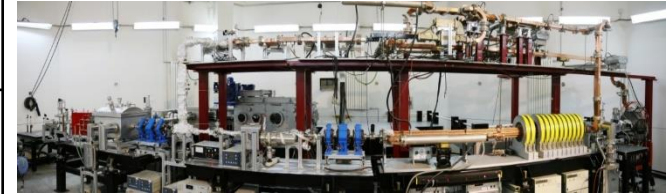
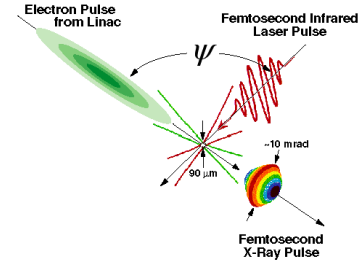

Accelerating gradient summary

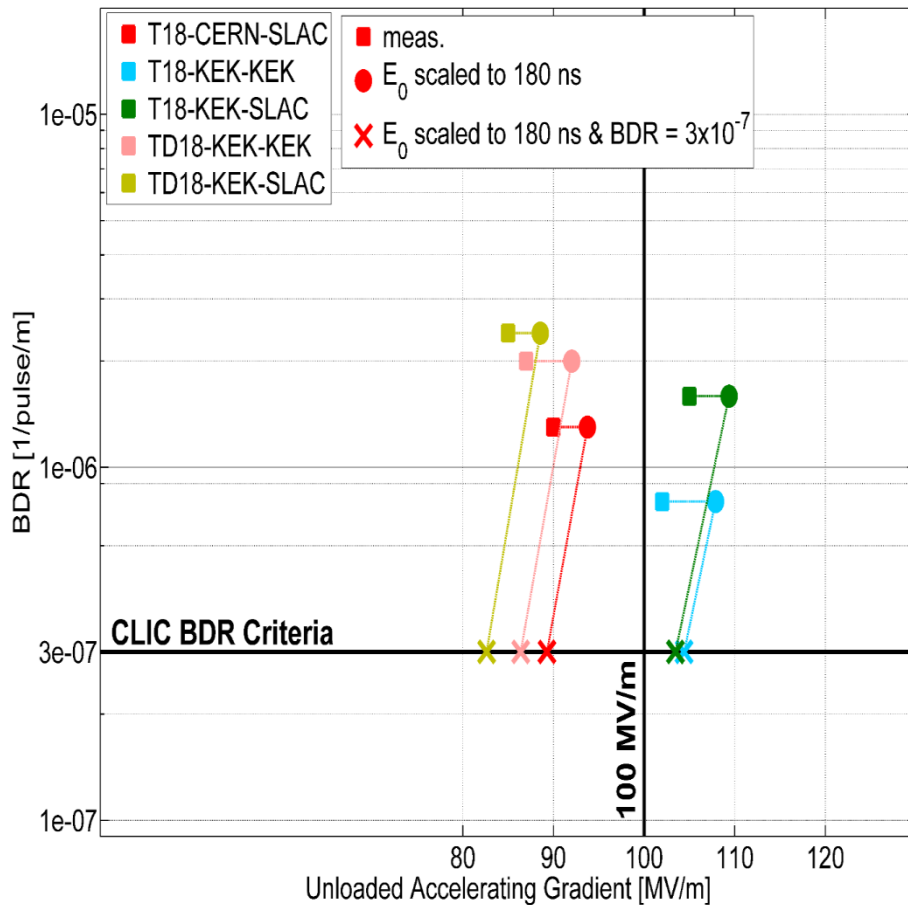

Original test structure geometry.

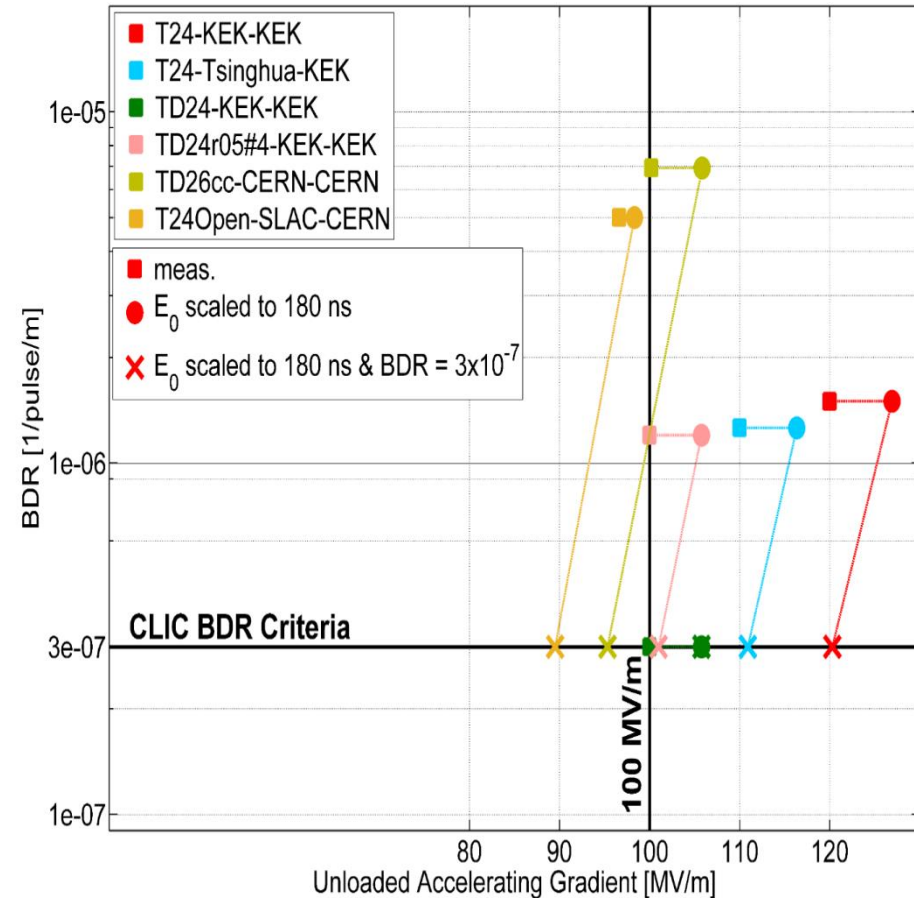

Baseline geometry, CLIC-G.

Newly optimized geometry, based on these results,
CLIC-G* now in production pipeline.



Beam tuning at FACET (SLAC)

Dispersion-free steering

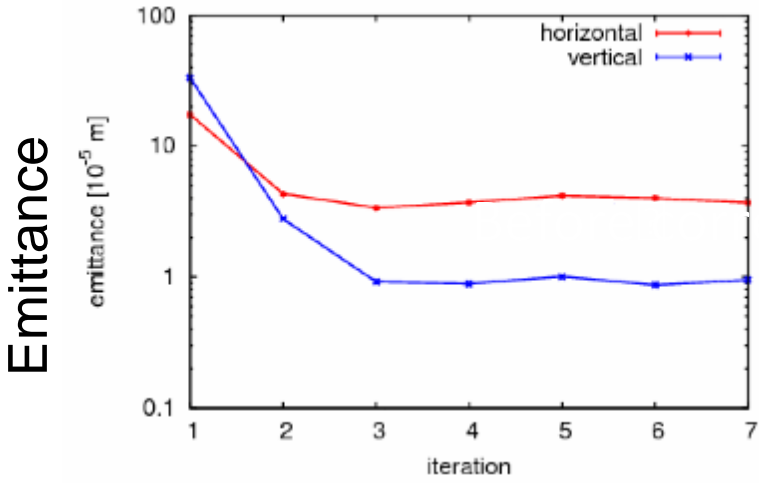

Timestamp: 20130313_013214

Orbit/Dispersion

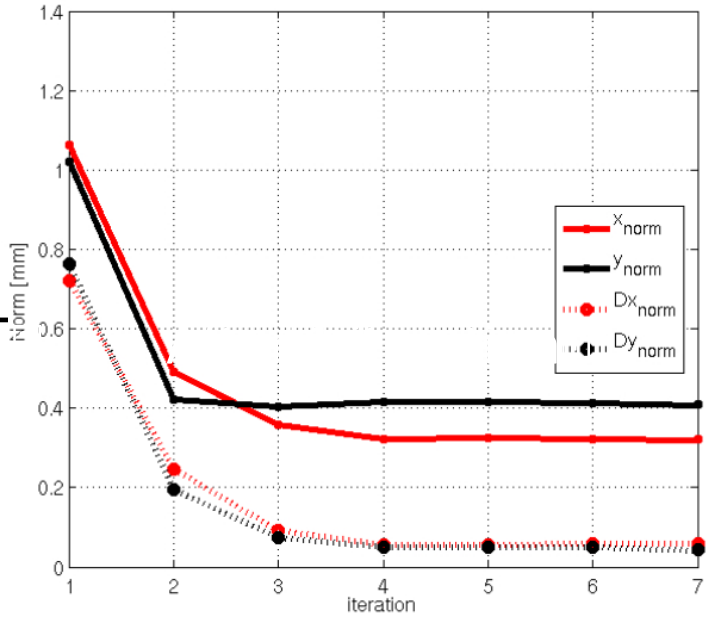

Beam profile measurement

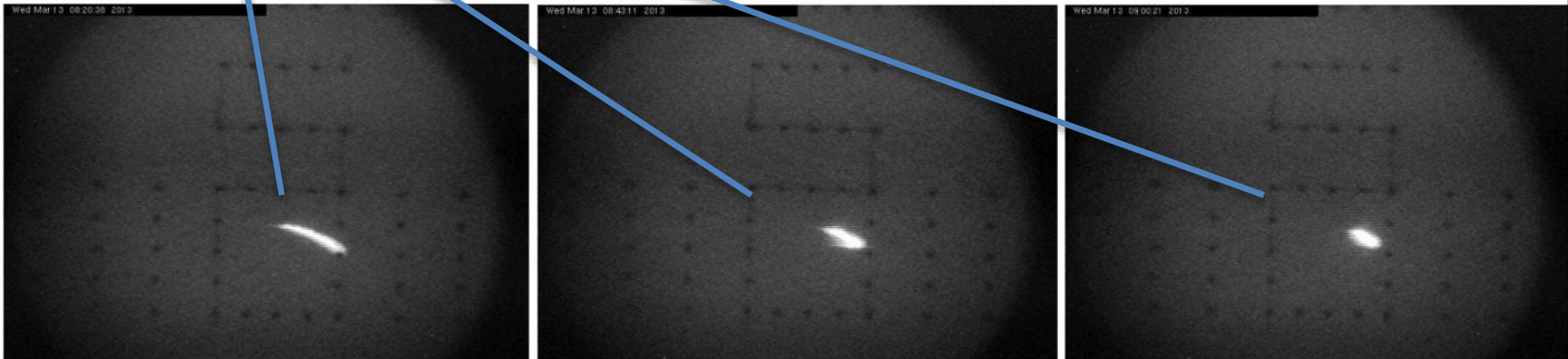

FACET measurements of wakefields

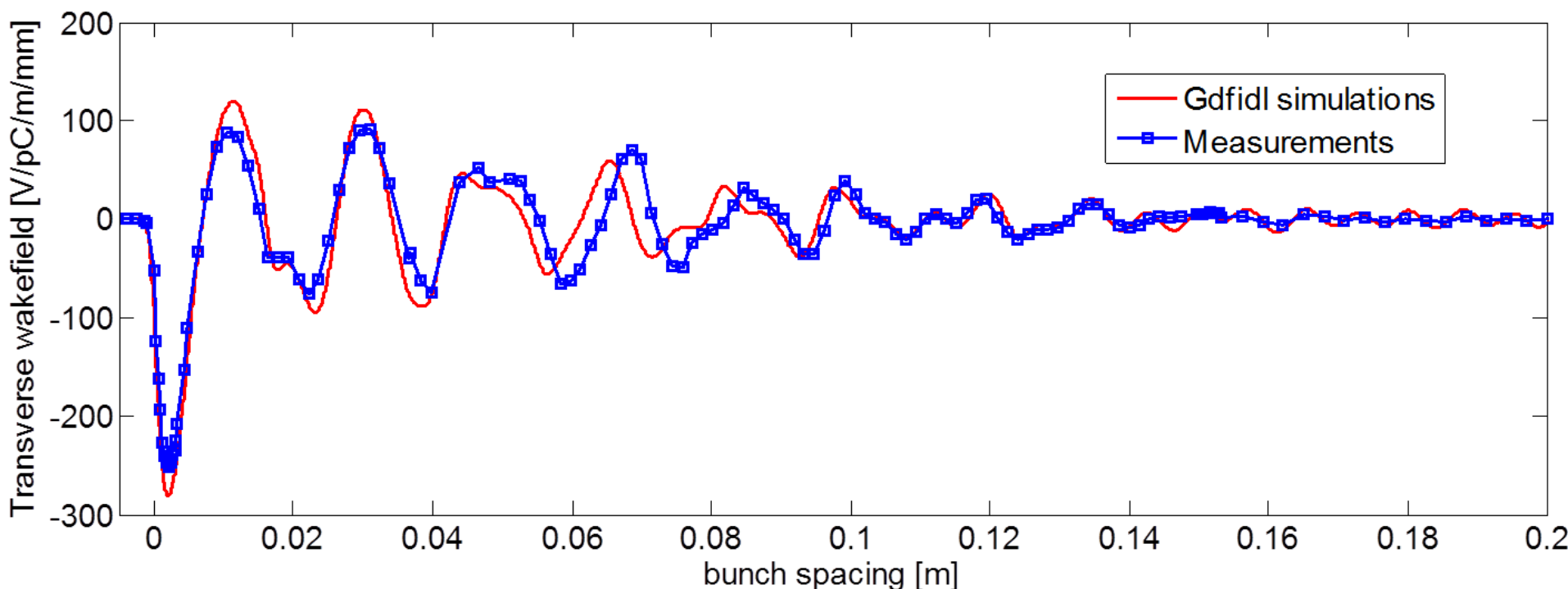
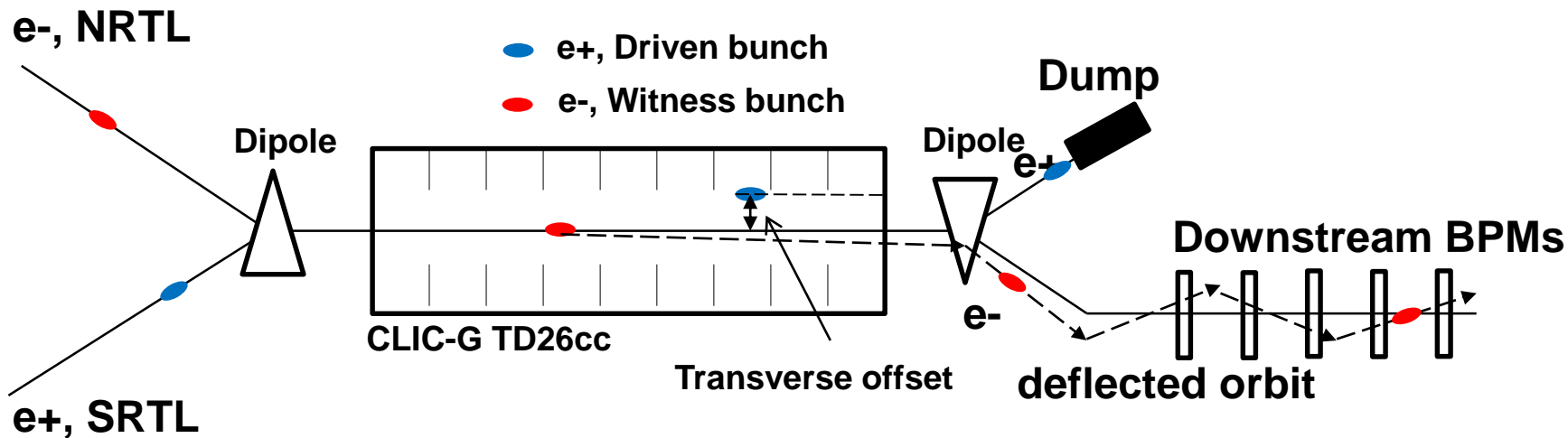



AC power

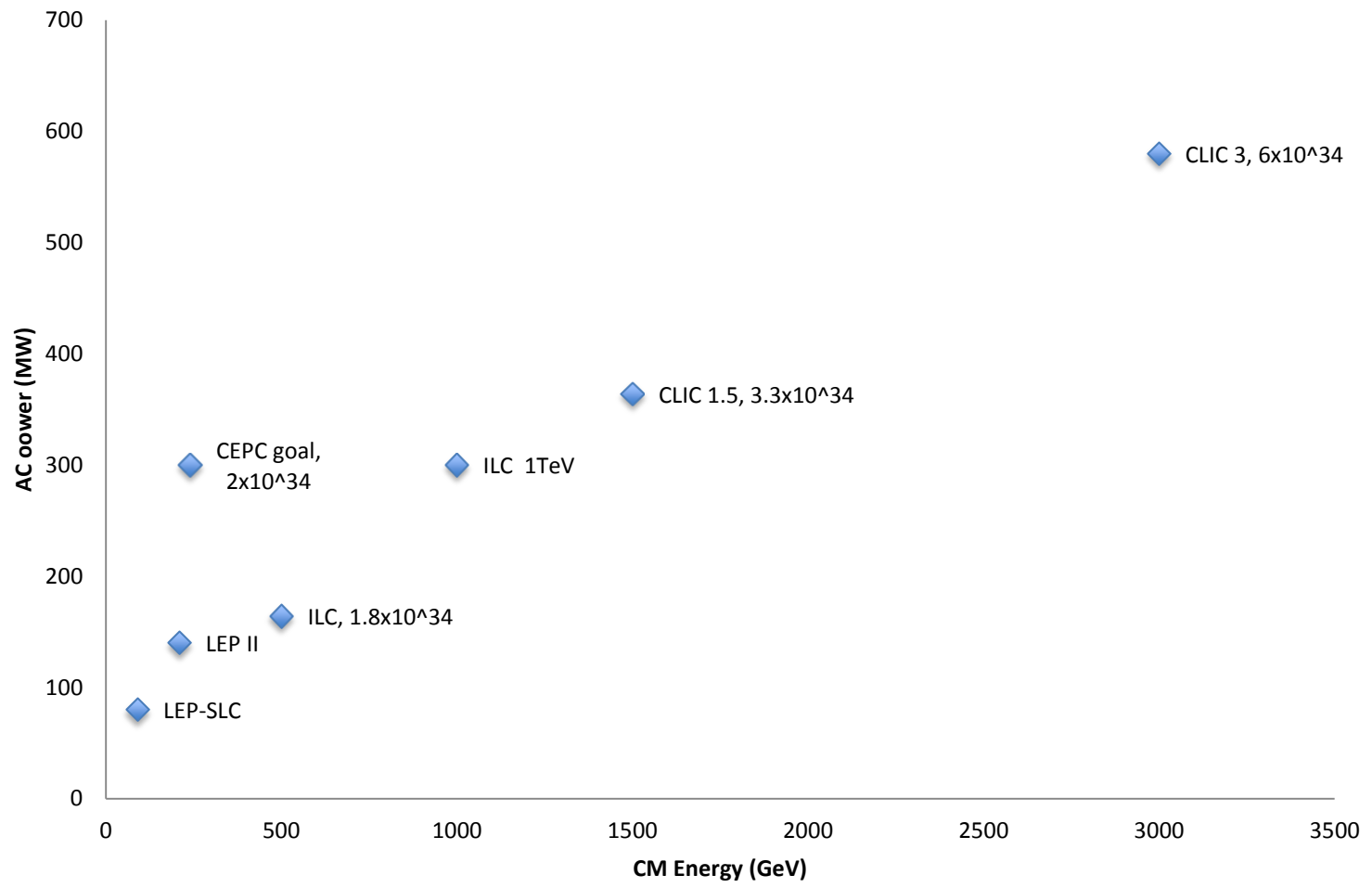

Energy consumption

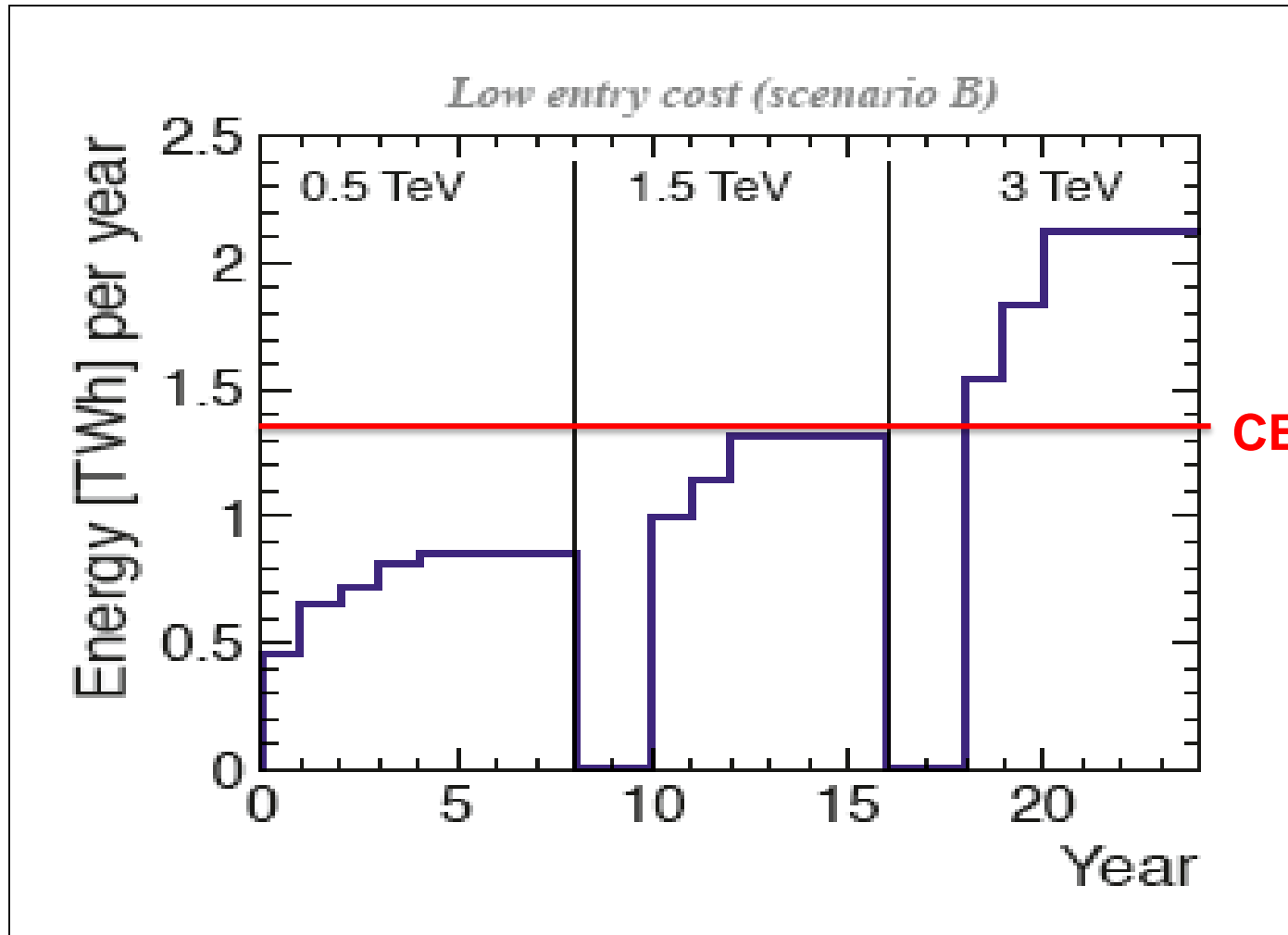

CERN 2012

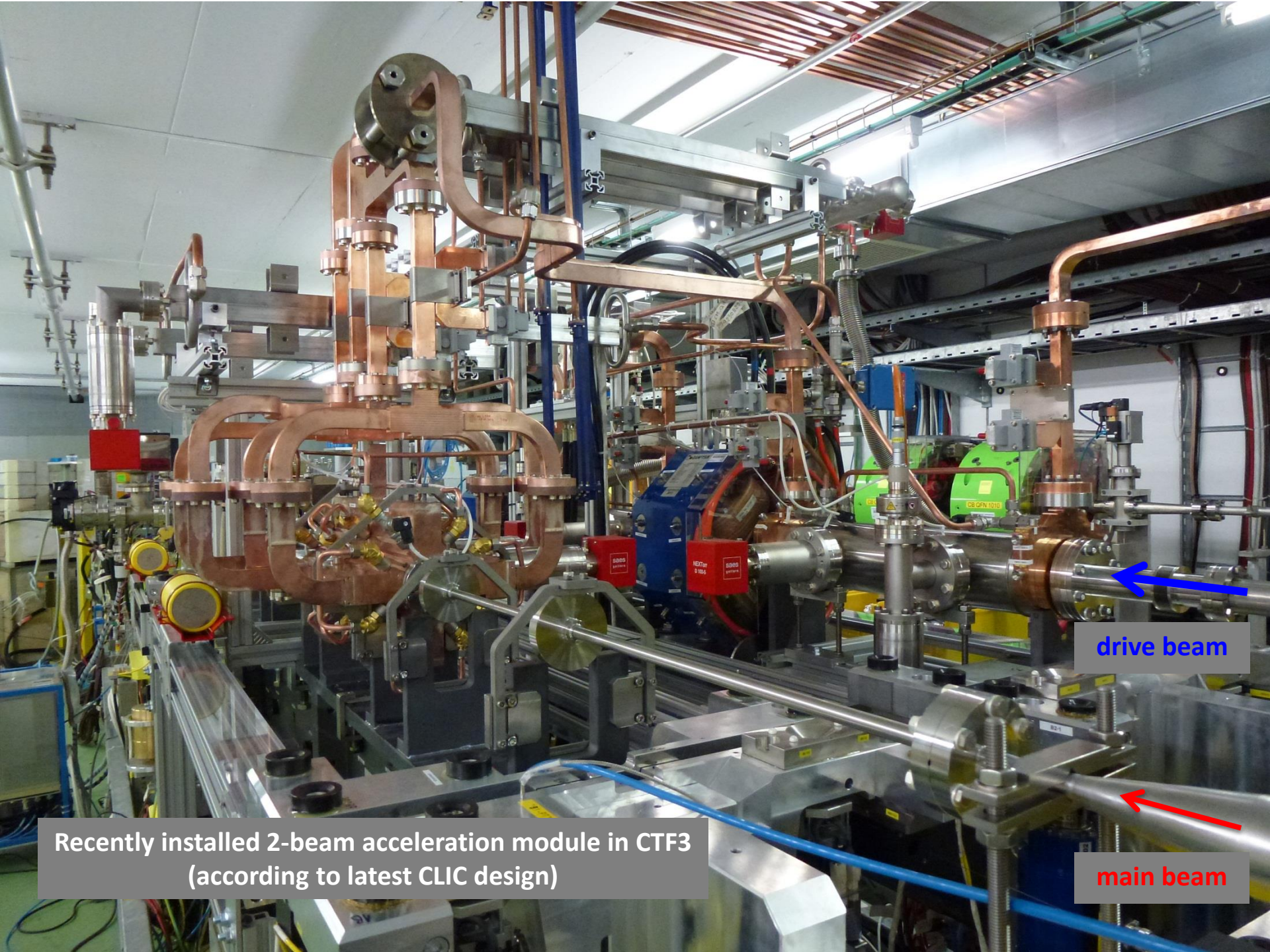

Recently installed 2-beam acceleration module in CTF3
(according to latest CLIC design)

drive beam

main beam

**Module mechanical characterisation test stand:
active alignment, fiducialisation + stabilisation (PACMAN)**



CLIC Higgs physics processes

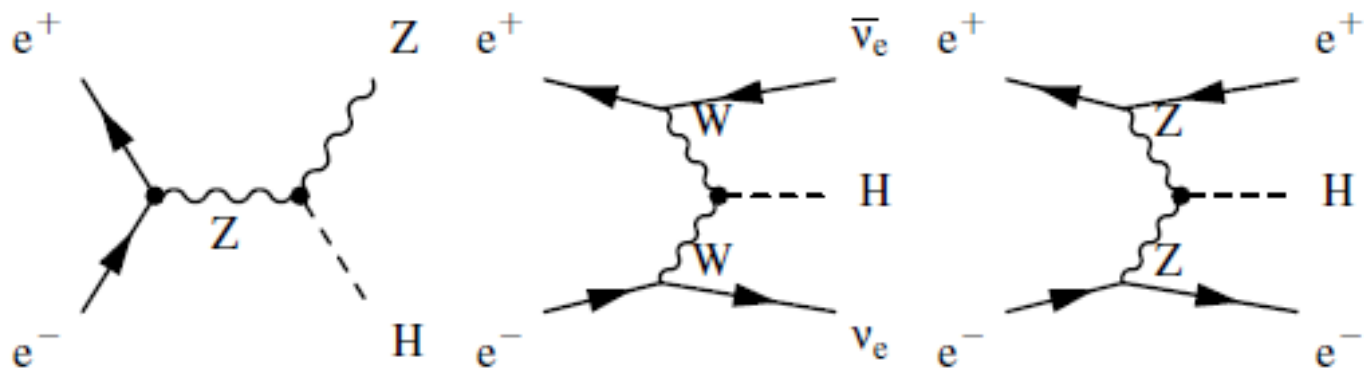

Figure 2: The three highest cross section Higgs production processes at CLIC.

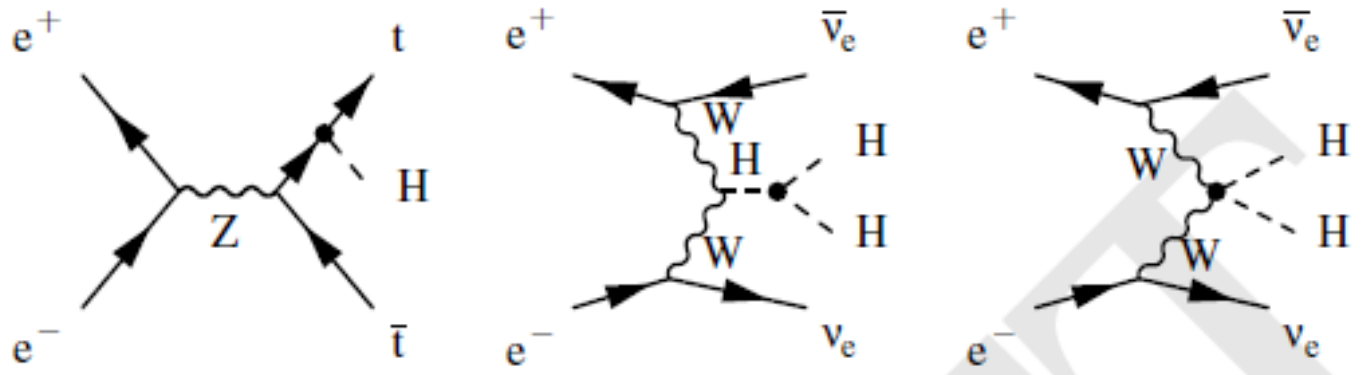
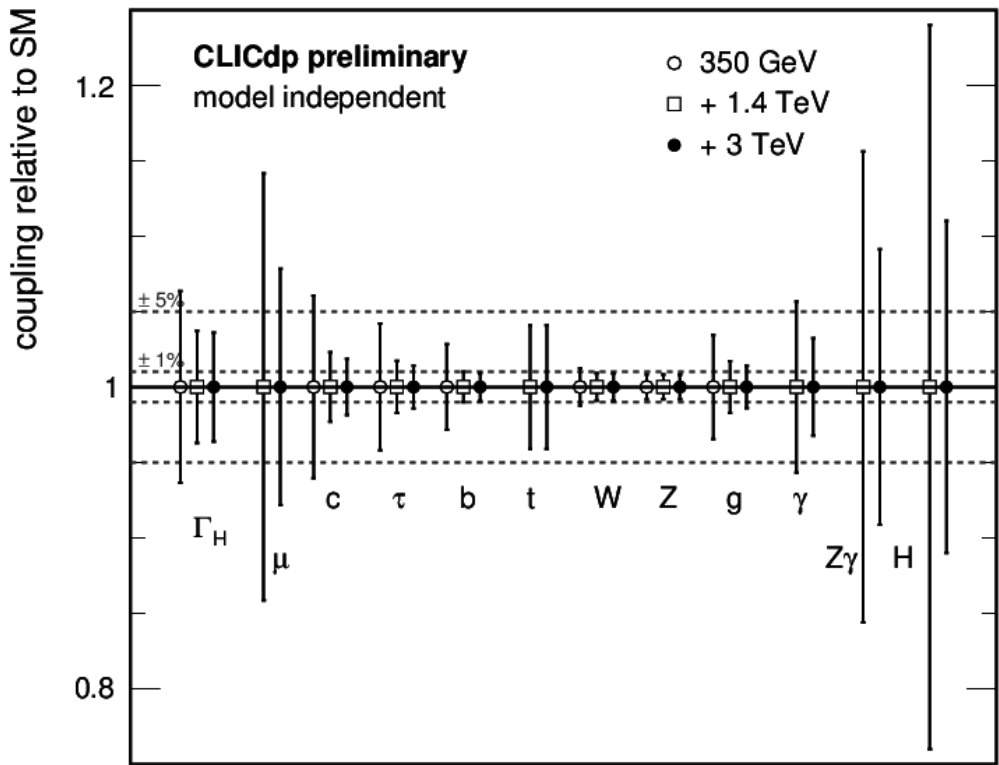

Figure 3: The main processes at CLIC involving the top Yukawa coupling g_{Htt} , the Higgs boson trilinear self-coupling λ and the quartic coupling g_{HHWW} .



CLIC Higgs physics capabilities



Parameter	Relative precision		
	350 GeV 500 fb ⁻¹	+ 1.4 TeV + 1.5 ab ⁻¹	+ 3 TeV + 2 ab ⁻¹
g_{HZZ}	0.8%	0.8%	0.8%
g_{HWW}	1.3%	0.9%	0.9%
g_{Hbb}	2.8%	1.0%	0.9%
g_{Hcc}	6.0%	2.3%	1.9%
$g_{H\tau\tau}$	4.2%	1.7%	1.4%
$g_{H\mu\mu}$	—	14.1%	7.8%
g_{Htt}	—	4.1%	4.1%
g_{Hgg}^\dagger	3.6%	1.7%	1.4%
$g_{H\gamma\gamma}^\dagger$	—	5.7%	3.2%
$g_{HZ\gamma}^\dagger$	—	15.6%	9.1%
Γ_H	6.4%	3.7%	3.6%



CLIC Higgs physics capabilities

Higgs couplings to heavy particles benefit from higher c.m. energies:

$ttH \sim 4\%$

$HH \sim 10\%$

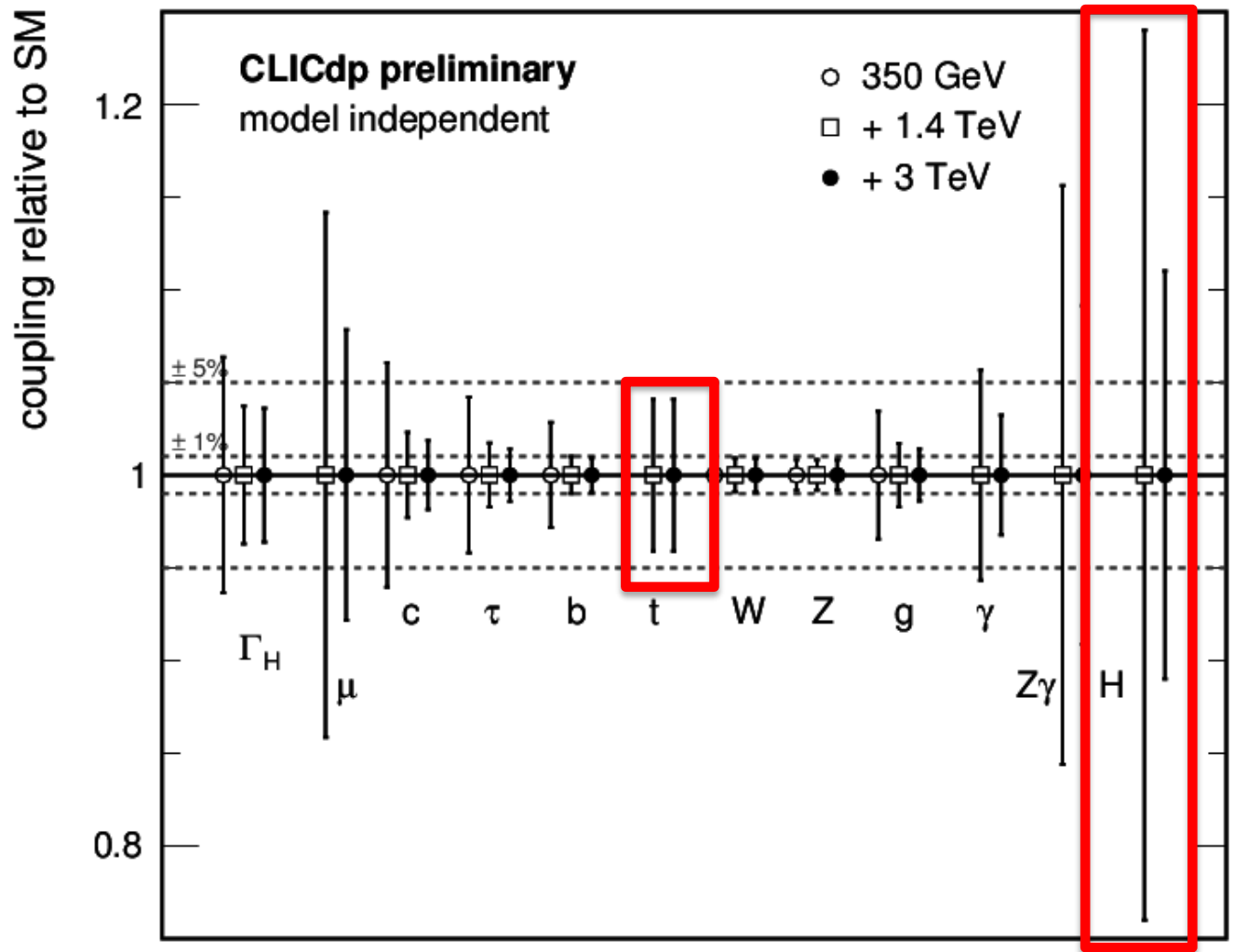



CLIC Higgs physics paper

**Higgs Physics at the CLIC Electron-Positron Linear Collider
(CLICdp collaboration paper)**

40 pages, 123 authors, >25 full-simulation studies

[CLICdp-Pub-2016-001](#) and [arXiv:1608.07538](#) (29/8/2016)

Submitted to EPJC – now addressing referees' comments

CLIC top physics example: form factors (380 GeV)

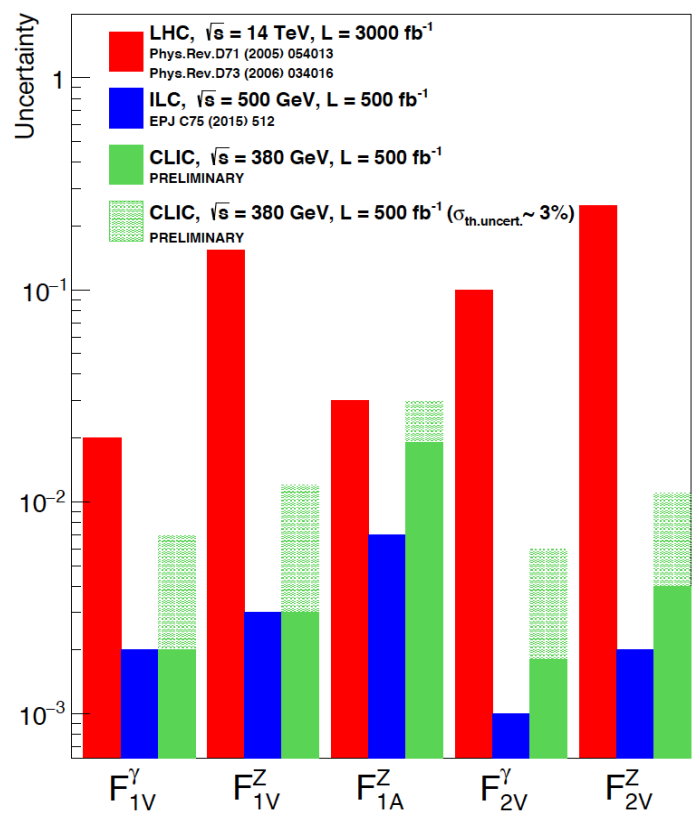

Figure 9: Uncertainties of the top quark form factors (assuming SM values for the remaining form factors) compared between estimations for LHC, ILC and CLIC [10]. The form factors are extracted from the measured forward backward asymmetry and cross-section. For the ILC, $\pm 80\%$ e^- polarisation and $\mp 30\%$ e^+ polarisation are considered and for CLIC, $\pm 80\%$ e^-

New CLIC detector model

return yoke (Fe)
with muon-ID
detectors

superconducting
solenoid, 4 Tesla

fine grained (PFA)
calorimetry, $1 + 7.5 \Lambda_i$,
Si-W ECAL, Sc-FE HCAL

silicon tracker,
(large pixels / short
strips)

*Note: final beam
focusing is outside
the detector*

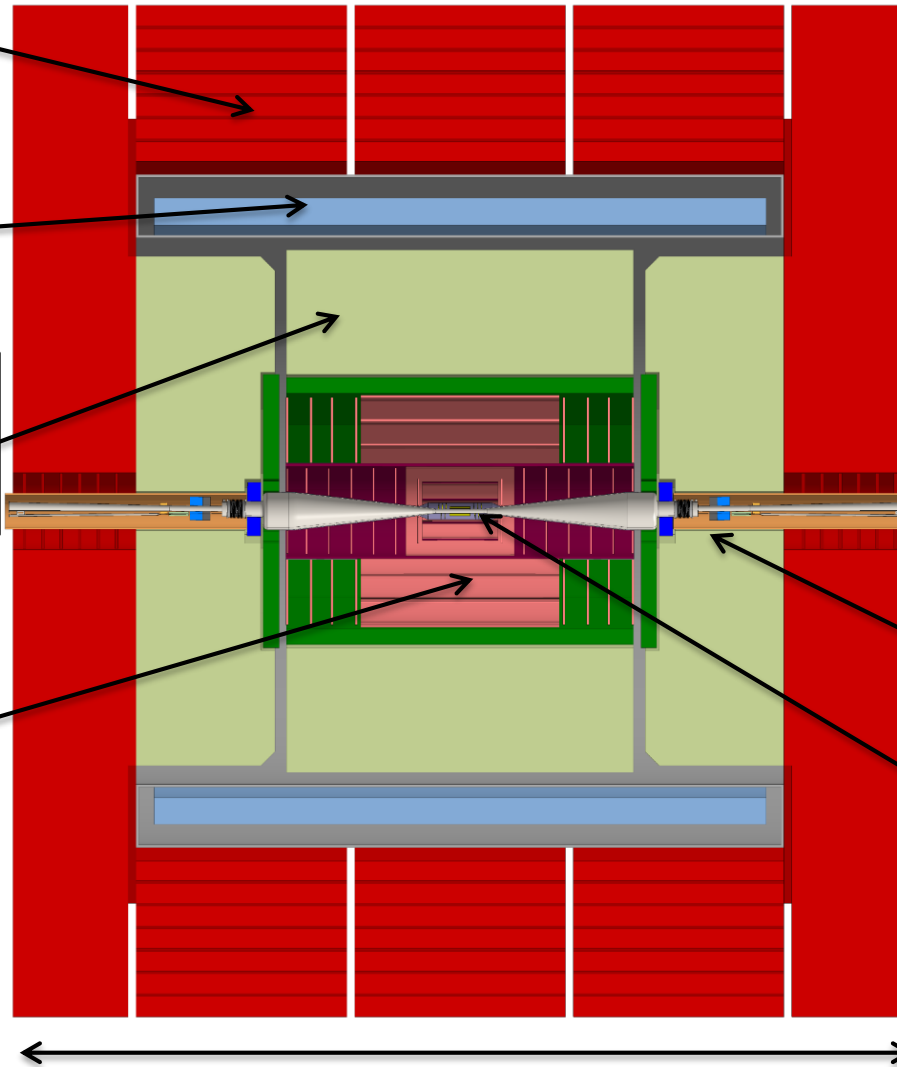

11.4 m

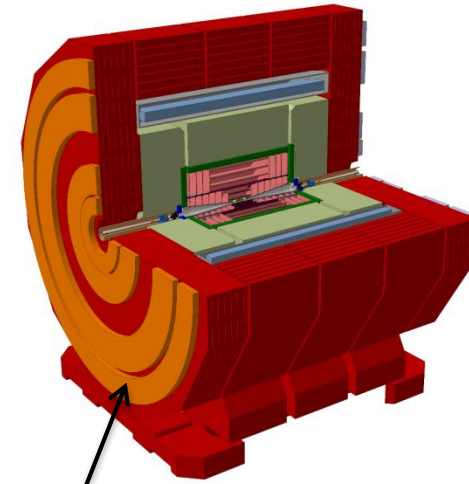

end-coils for
field shaping

forward region with
compact forward
calorimeters

ultra low-mass
vertex detector,
 $\sim 25 \mu\text{m}$ pixels