

Performing precision measurements and new physics searches at the HL-LHC with the upgraded CMS Level-1 Trigger

a.k.a.

CMS' Adventures in the Level-1 Trigger Wonderland

Jona Motta (LLR, École Polytechnique)
on behalf of the CMS Collaboration

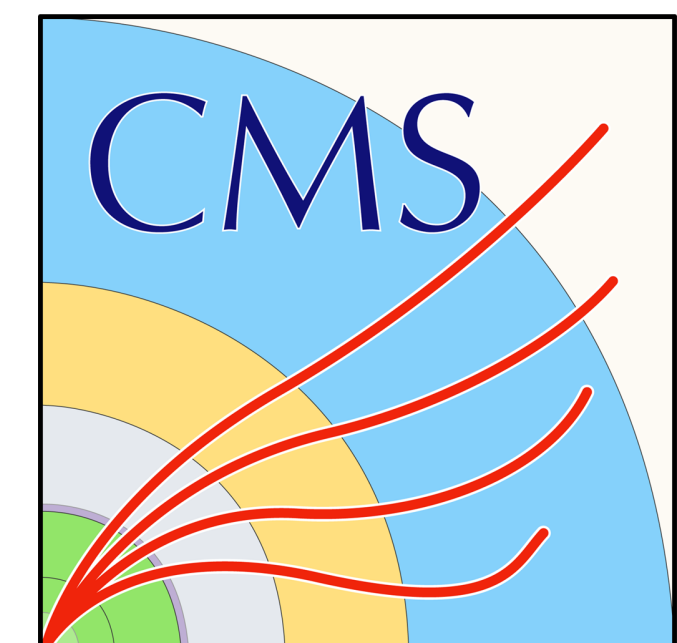

HL-LHC and CMS Phase-2

**TODAY'S
MENU**

Preserving the discovery potential
(with the Phase-2 Trigger)

Extending the physics reach
(with the Phase-2 Trigger)

Conclusions and outlook



HL-LHC and CMS Phase-2

High Luminosity LHC and CMS Phase-2 upgrade

- **High Luminosity LHC** will start in 2029 and will integrate **10 times the LHC luminosity**, and have an **instantaneous luminosity 3 times the Run 2 peak value**

⇒ **unprecedented levels of radiation and number of simultaneous collisions** (~70@LHC → ~200@HL-LHC)

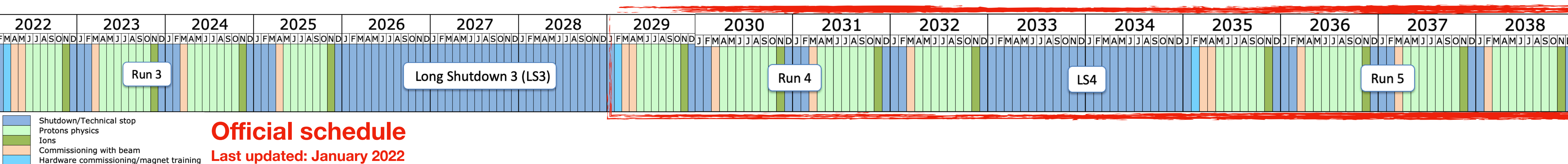

[source](#)

High Luminosity LHC and CMS Phase-2 upgrade

- **High Luminosity LHC** will start in 2029 and will integrate **10 times the LHC luminosity**, and have an **instantaneous luminosity 3 times the Run 2 peak value**

⇒ **unprecedented levels of radiation and number of simultaneous collisions** (~70@LHC → ~200@HL-LHC)

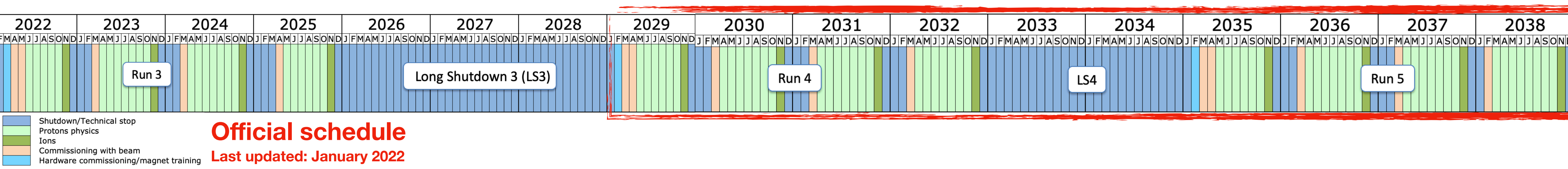

[source](#)

- The CMS experiment will be upgraded mainly (but not only) by:

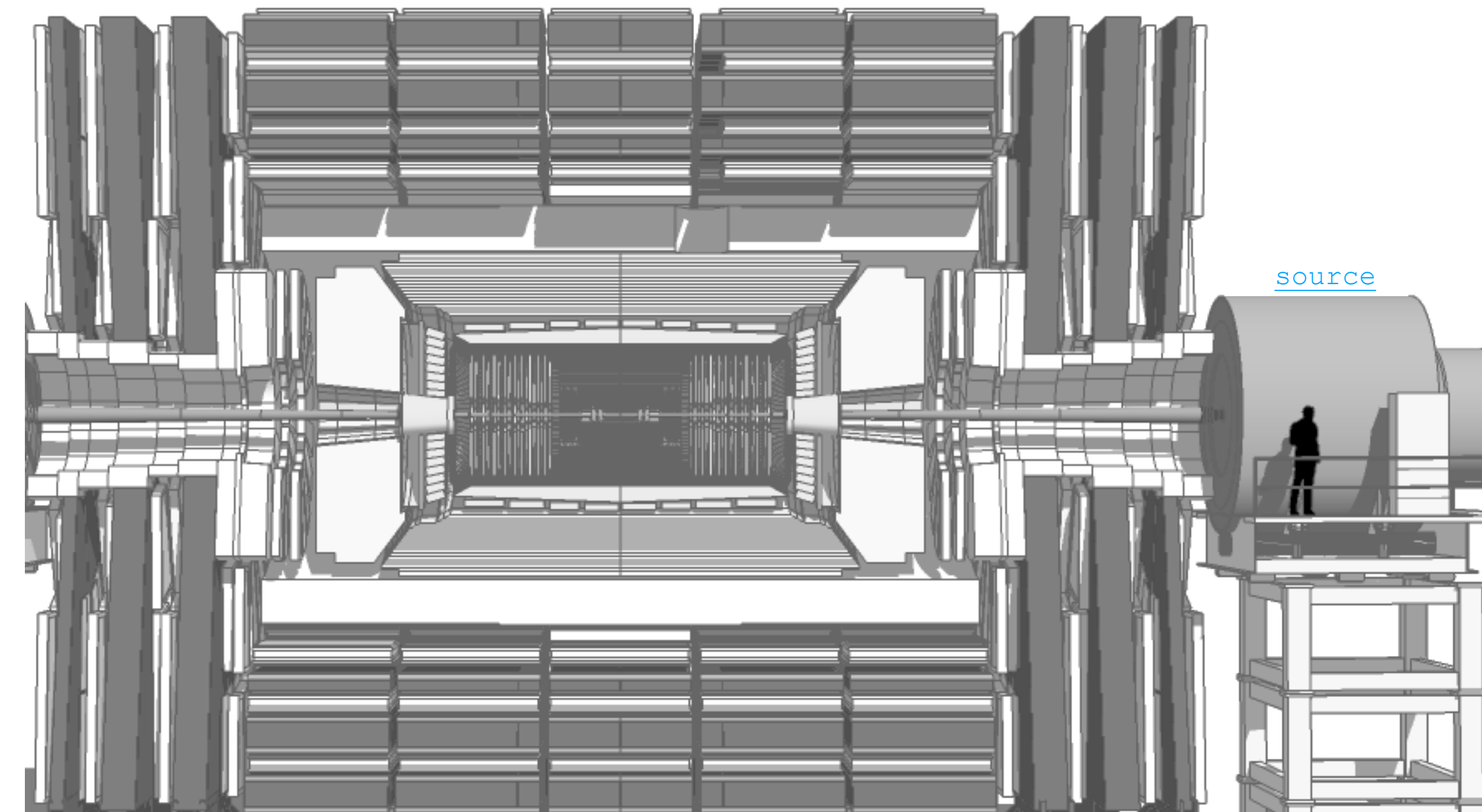

High Luminosity LHC and CMS Phase-2 upgrade

- **High Luminosity LHC** will start in 2029 and will integrate **10 times the LHC luminosity**, and have an **instantaneous luminosity 3 times the Run 2 peak value**

⇒ **unprecedented levels of radiation and number of simultaneous collisions** (~70@LHC → ~200@HL-LHC)

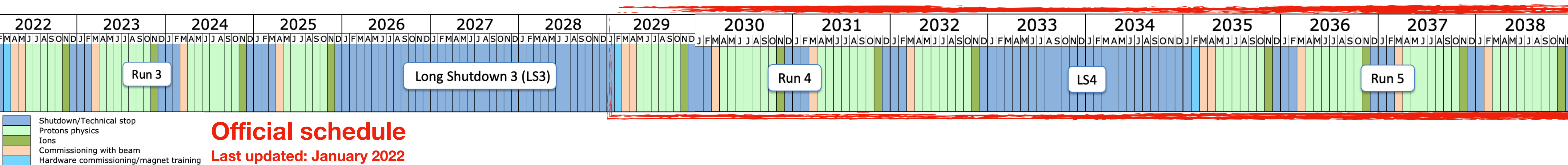

[source](#)

- The CMS experiment will be upgraded mainly (but not only) by:
 - * replacing the **tracking detectors** [TDR](#)

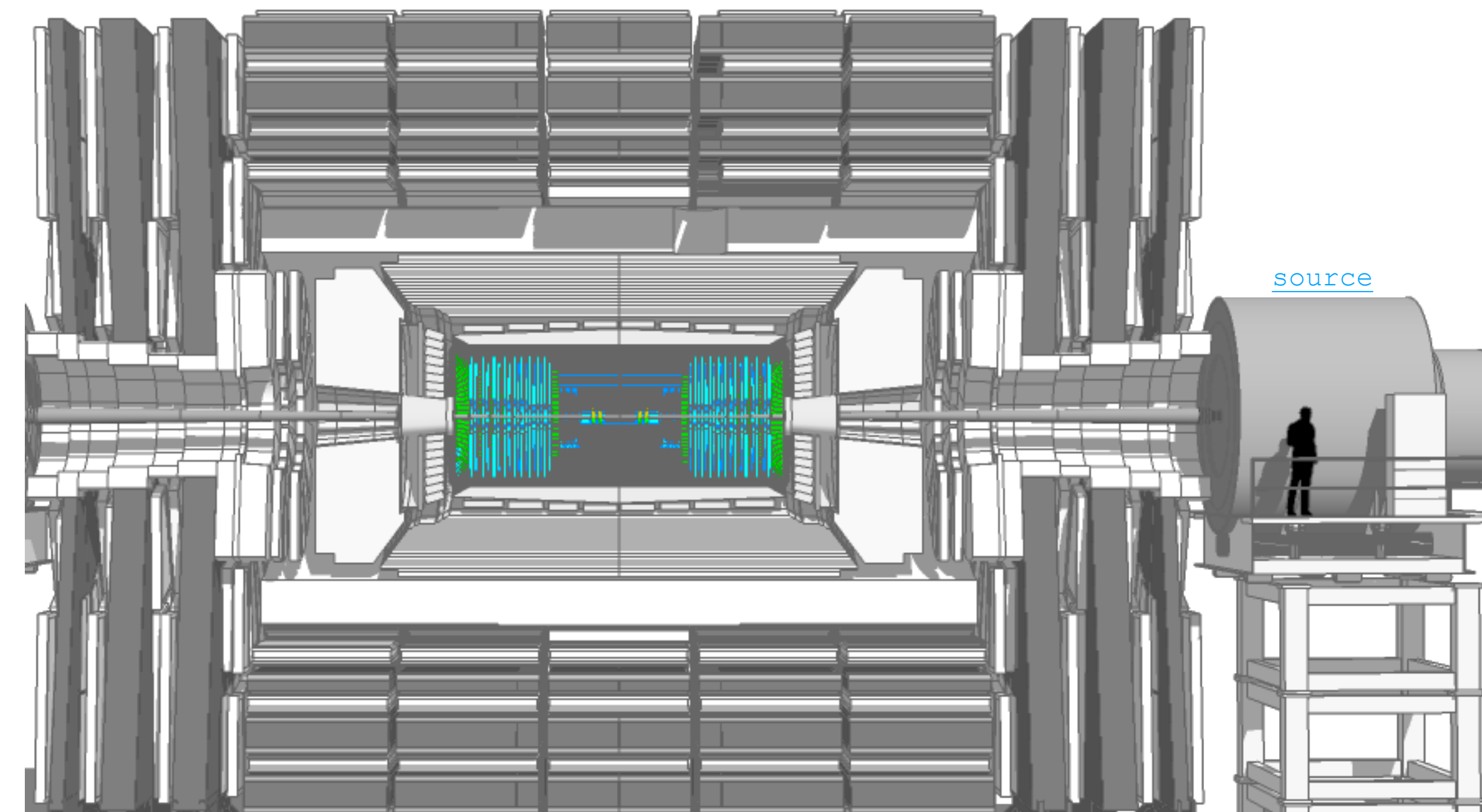

High Luminosity LHC and CMS Phase-2 upgrade

- **High Luminosity LHC** will start in 2029 and will integrate **10 times the LHC luminosity**, and have an **instantaneous luminosity 3 times the Run 2 peak value**

⇒ **unprecedented levels of radiation and number of simultaneous collisions** (~70@LHC → ~200@HL-LHC)

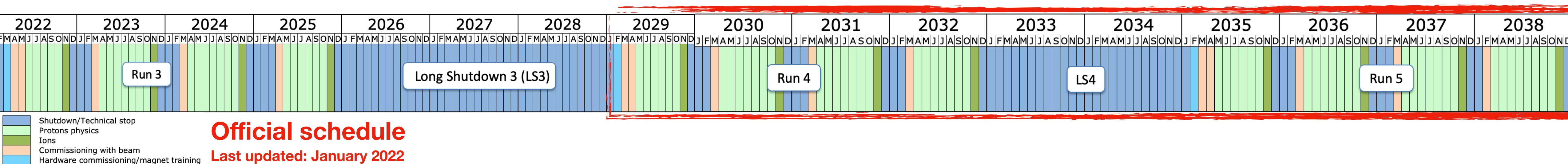

[source](#)

- The CMS experiment will be upgraded mainly (but not only) by:
 - * replacing the **tracking detectors** [TDR](#)
 - * replacing the **barrel calorimeters electronics** [TDR](#)

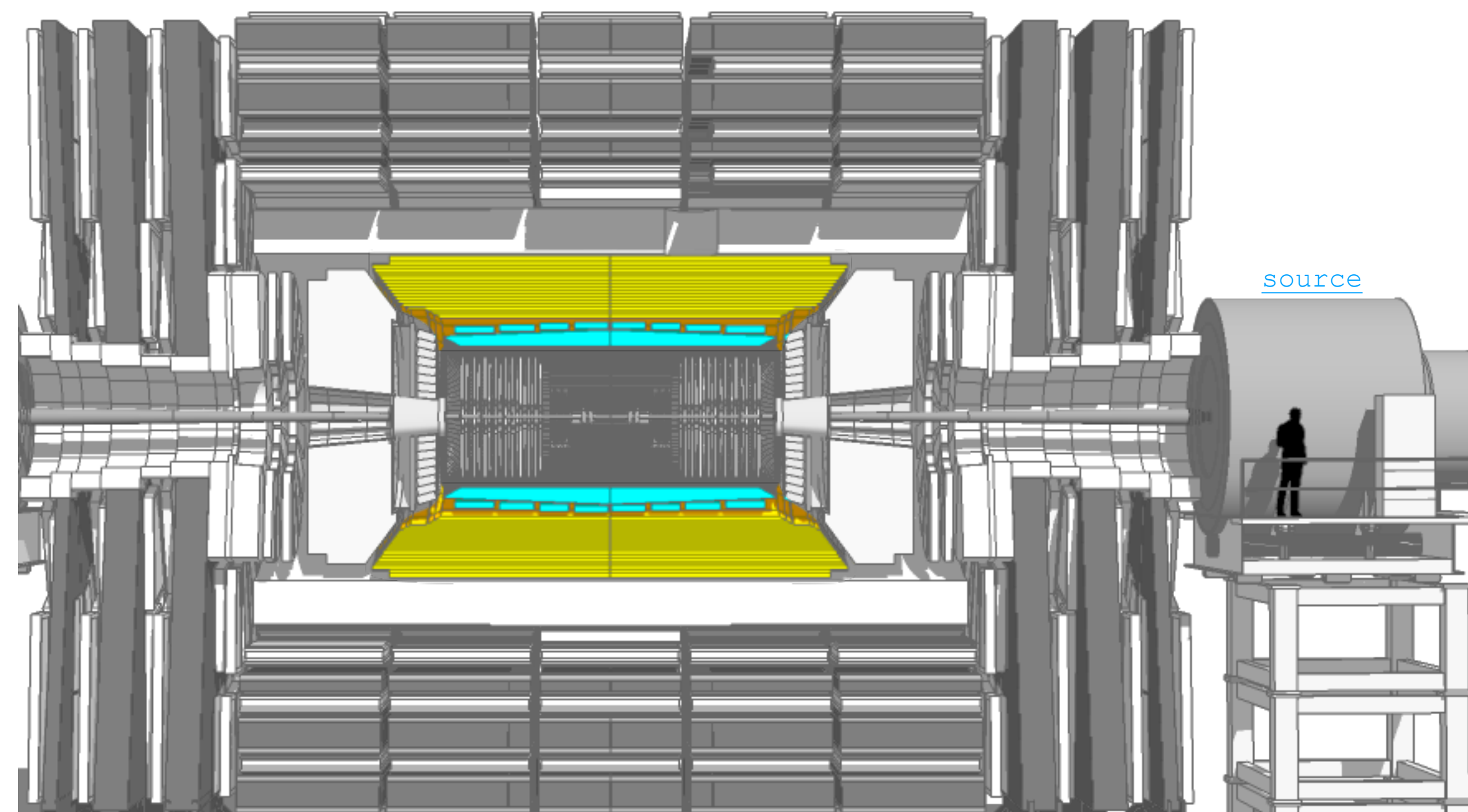

High Luminosity LHC and CMS Phase-2 upgrade

- **High Luminosity LHC** will start in 2029 and will integrate **10 times the LHC luminosity**, and have an **instantaneous luminosity 3 times the Run 2 peak value**

⇒ **unprecedented levels of radiation and number of simultaneous collisions** (~70@LHC → ~200@HL-LHC)

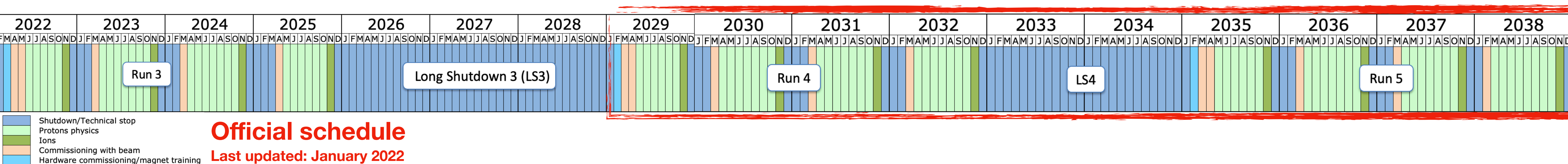

[source](#)

- The CMS experiment will be upgraded mainly (but not only) by:
 - * replacing the **tracking detectors** [TDR](#)
 - * replacing the **barrel calorimeters electronics** [TDR](#)
 - * replacing the **endcap muon detectors** [TDR](#)

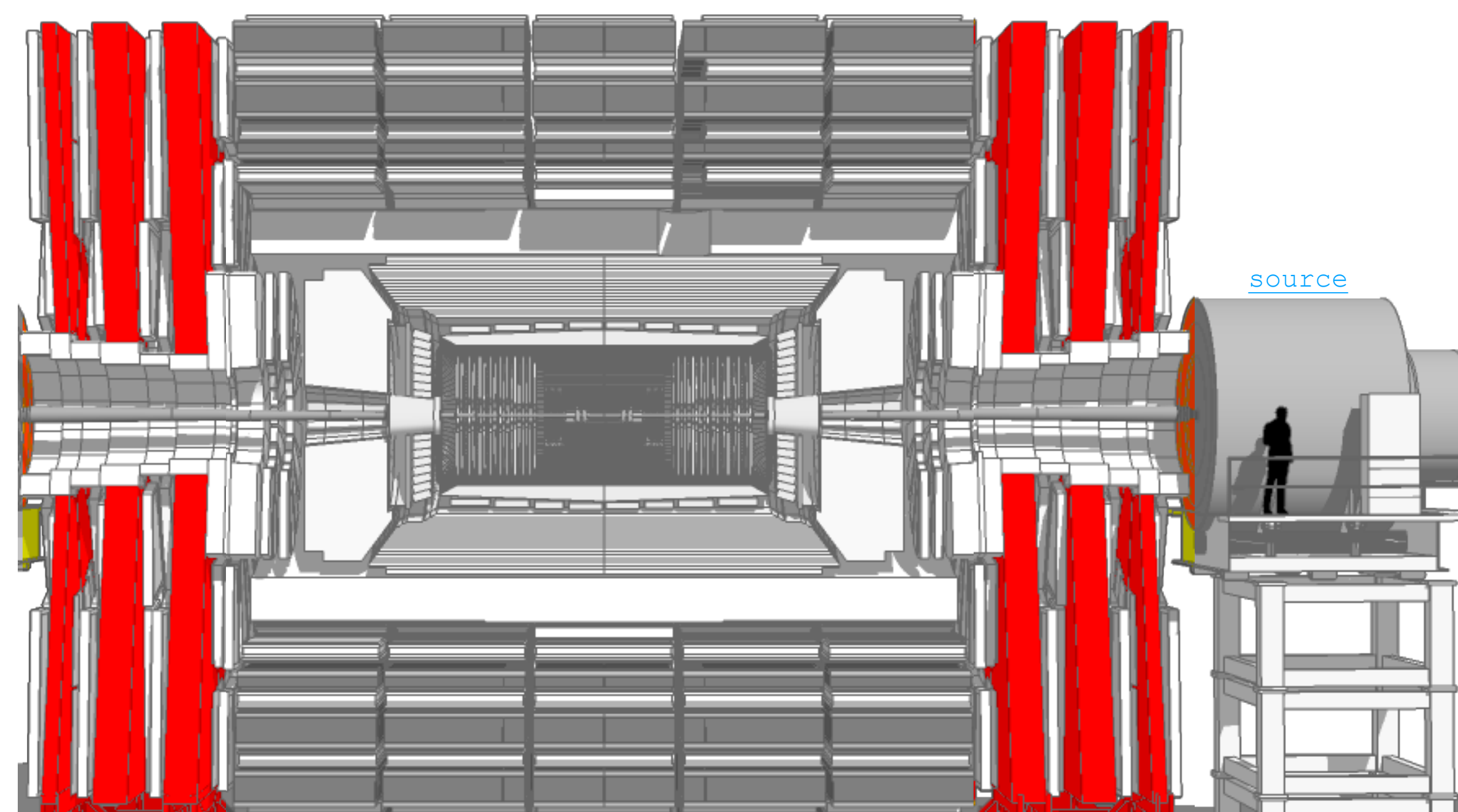

High Luminosity LHC and CMS Phase-2 upgrade

- **High Luminosity LHC** will start in 2029 and will integrate **10 times the LHC luminosity**, and have an **instantaneous luminosity 3 times the Run 2 peak value**

⇒ **unprecedented levels of radiation and number of simultaneous collisions** (~70@LHC → ~200@HL-LHC)

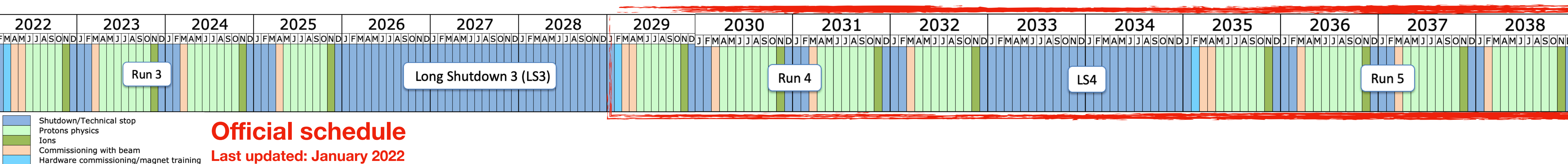

[source](#)

- The CMS experiment will be upgraded mainly (but not only) by:
 - * replacing the **tracking detectors** [TDR](#)
 - * replacing the **barrel calorimeters electronics** [TDR](#)
 - * replacing the **endcap muon detectors** [TDR](#)
 - * replacing the **endcap calorimeter** [TDR](#)

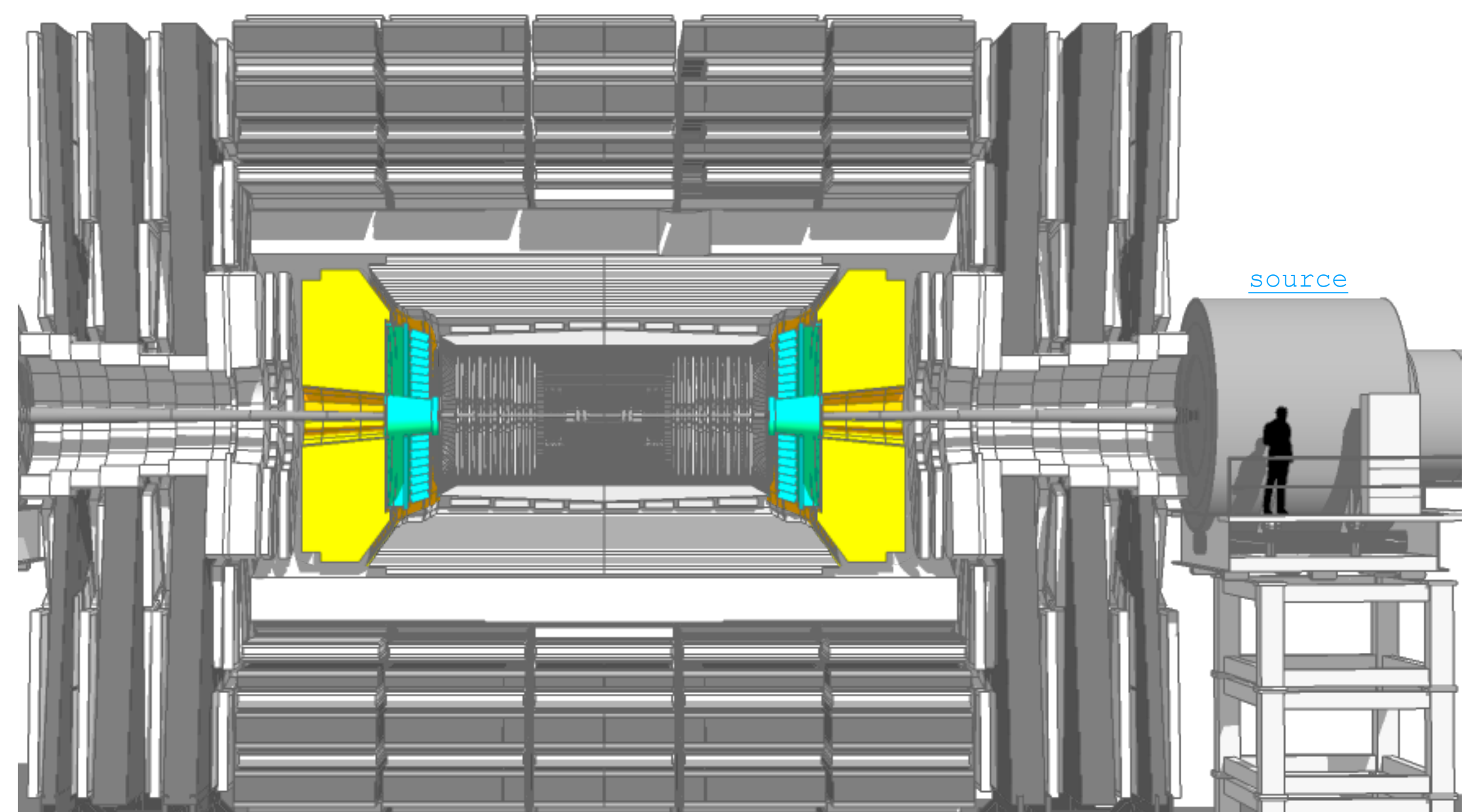

High Luminosity LHC and CMS Phase-2 upgrade

- **High Luminosity LHC** will start in 2029 and will integrate **10 times the LHC luminosity**, and have an **instantaneous luminosity 3 times the Run 2 peak value**

⇒ **unprecedented levels of radiation and number of simultaneous collisions** (~70@LHC → ~200@HL-LHC)

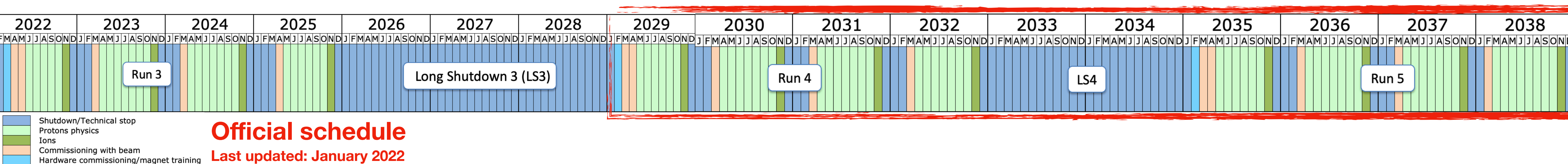

[source](#)

- The CMS experiment will be upgraded mainly (but not only) by:
 - * replacing the **tracking detectors** [TDR](#)
 - * replacing the **barrel calorimeters electronics** [TDR](#)
 - * replacing the **endcap muon detectors** [TDR](#)
 - * replacing the **endcap calorimeter** [TDR](#)
 - * introducing the **timing detector** [TDR](#)

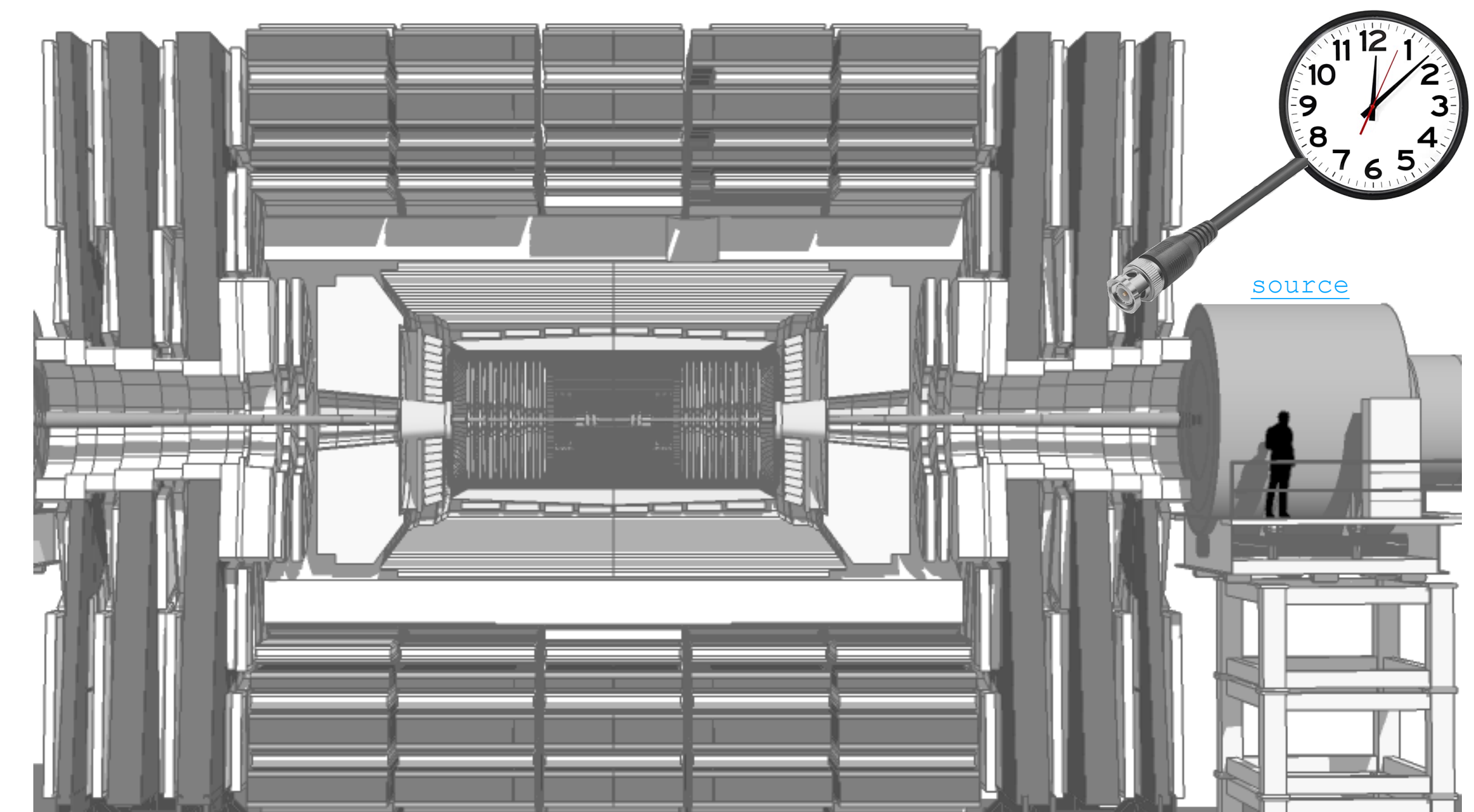

High Luminosity LHC and CMS Phase-2 upgrade

- **High Luminosity LHC** will start in 2029 and will integrate **10 times the LHC luminosity**, and have an **instantaneous luminosity 3 times the Run 2 peak value**

⇒ **unprecedented levels of radiation and number of simultaneous collisions** (~70@LHC → ~200@HL-LHC)

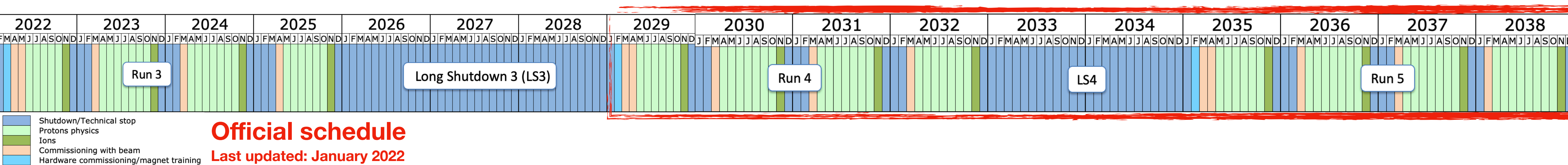

[source](#)

- The CMS experiment will be upgraded mainly (but not only) by:

- * replacing the **tracking detectors** [TDR](#)
- * replacing the **barrel calorimeters electronics** [TDR](#)
- * replacing the **endcap muon detectors** [TDR](#)
- * replacing the **endcap calorimeter** [TDR](#)
- * introducing the **timing detector** [TDR](#)
- * renewing the **Trigger** [TDR](#) and the **DAQ** [TDR](#)

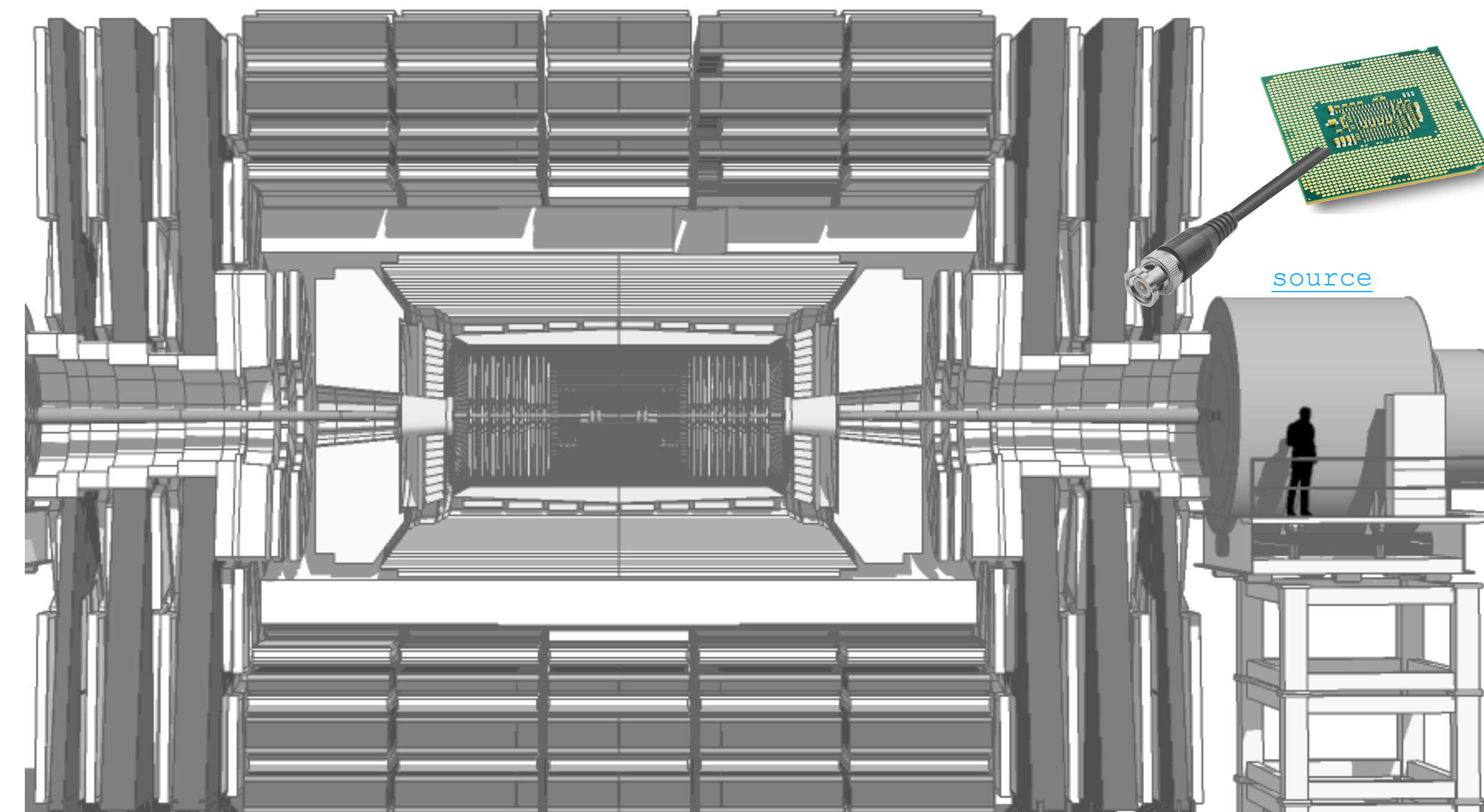

CMS Phase-2 Trigger

- The Phase-2 trigger system implements the well-established **two-level trigger architecture** with **Level-1 (L1)** and **High-Level-Trigger (HLT)**
- The **L1 trigger** will operate **at hardware level** implementing processor boards equipped with FPGAs and high-speed links
- The **HLT** will operate **at software level** using as input the CMS detector full-granularity information and more sophisticated algorithms

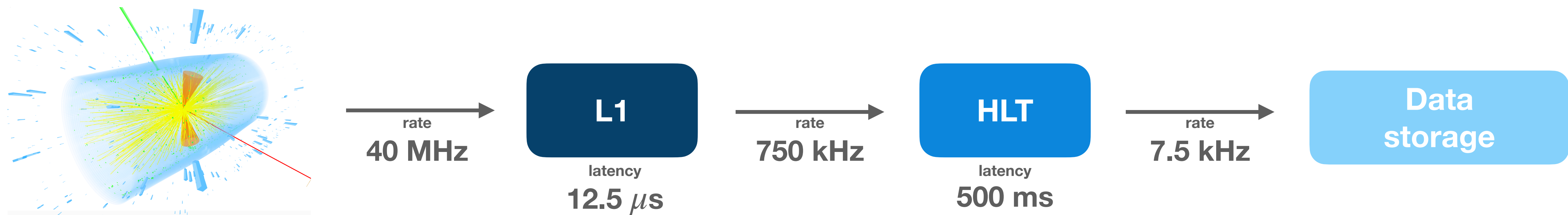

CMS Phase-2 Trigger

- The Phase-2 trigger system implements the well-established **two-level trigger architecture** with **Level-1 (L1)** and **High-Level-Trigger (HLT)**
- The **L1 trigger** will operate **at hardware level** implementing processor boards equipped with FPGAs and high-speed links
- The **HLT** will operate **at software level** using as input the CMS detector full-granularity information and more sophisticated algorithms

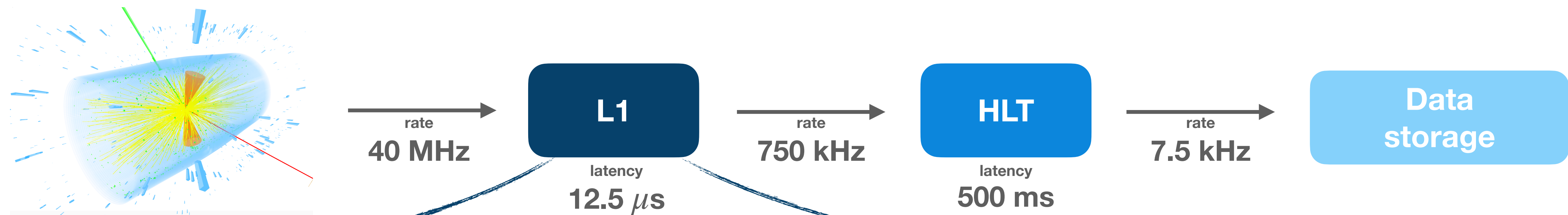

The **main hardware features** for the Phase-2 L1 Trigger system will be:

- * the use of **generic processor boards**
- * the use of **high-speed optical links** (*28Gb/s against the 10Gb/s in Phase-1*)
- * the extensive use of **state-of-the-art FPGAs** (*8 times more resources than in Phase-1*)
- * the implementation of a **modular architecture**

CMS Phase-2 Level-1 Trigger architecture

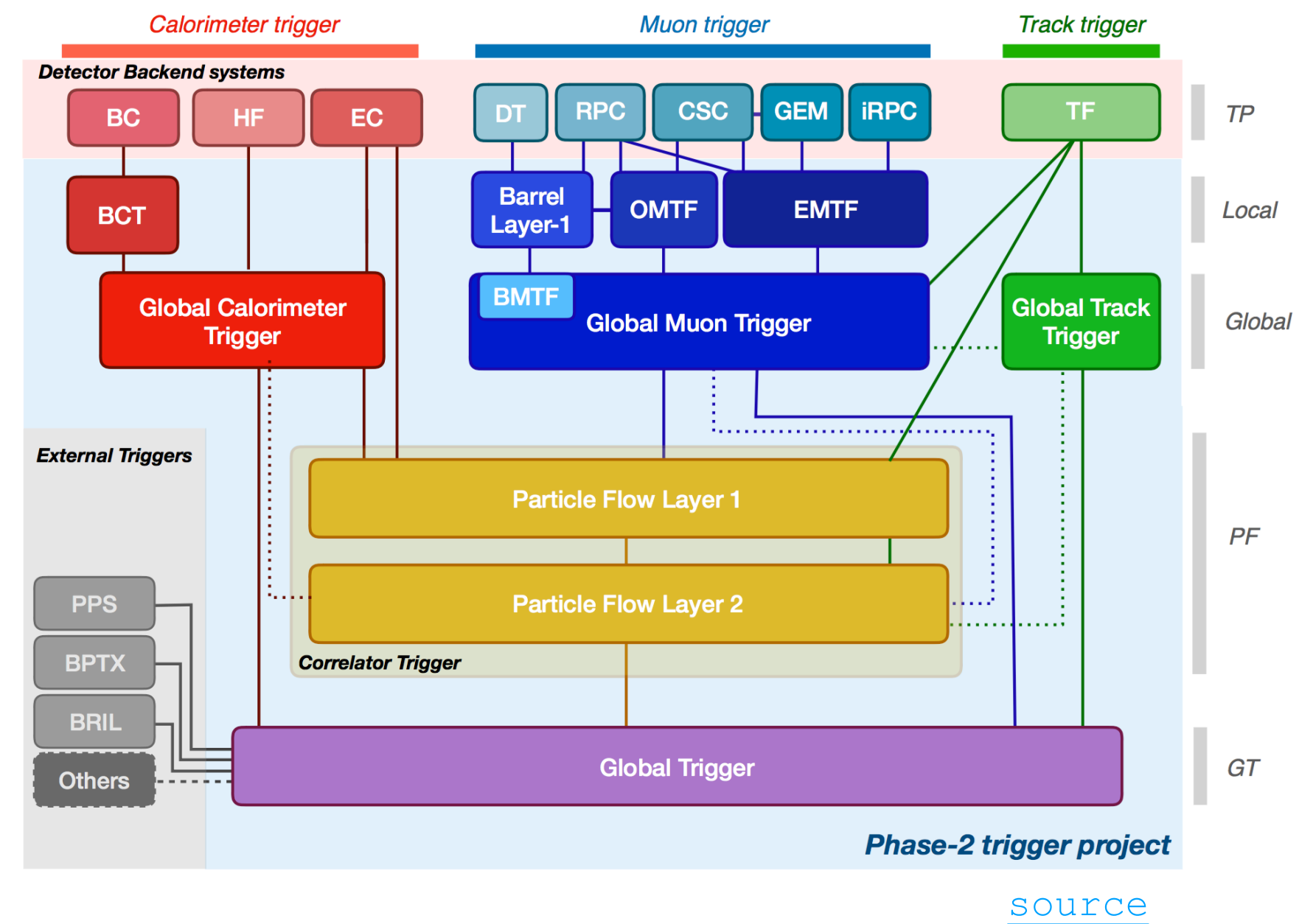

CMS Phase-2 Level-1 Trigger architecture

Calorimeter trigger

- * inclusion of the HGCal detector information
- * use of higher granularity (x25 in barrel ECAL)
- * production of high resolution clusters

reconstructs candidates from calo deposits

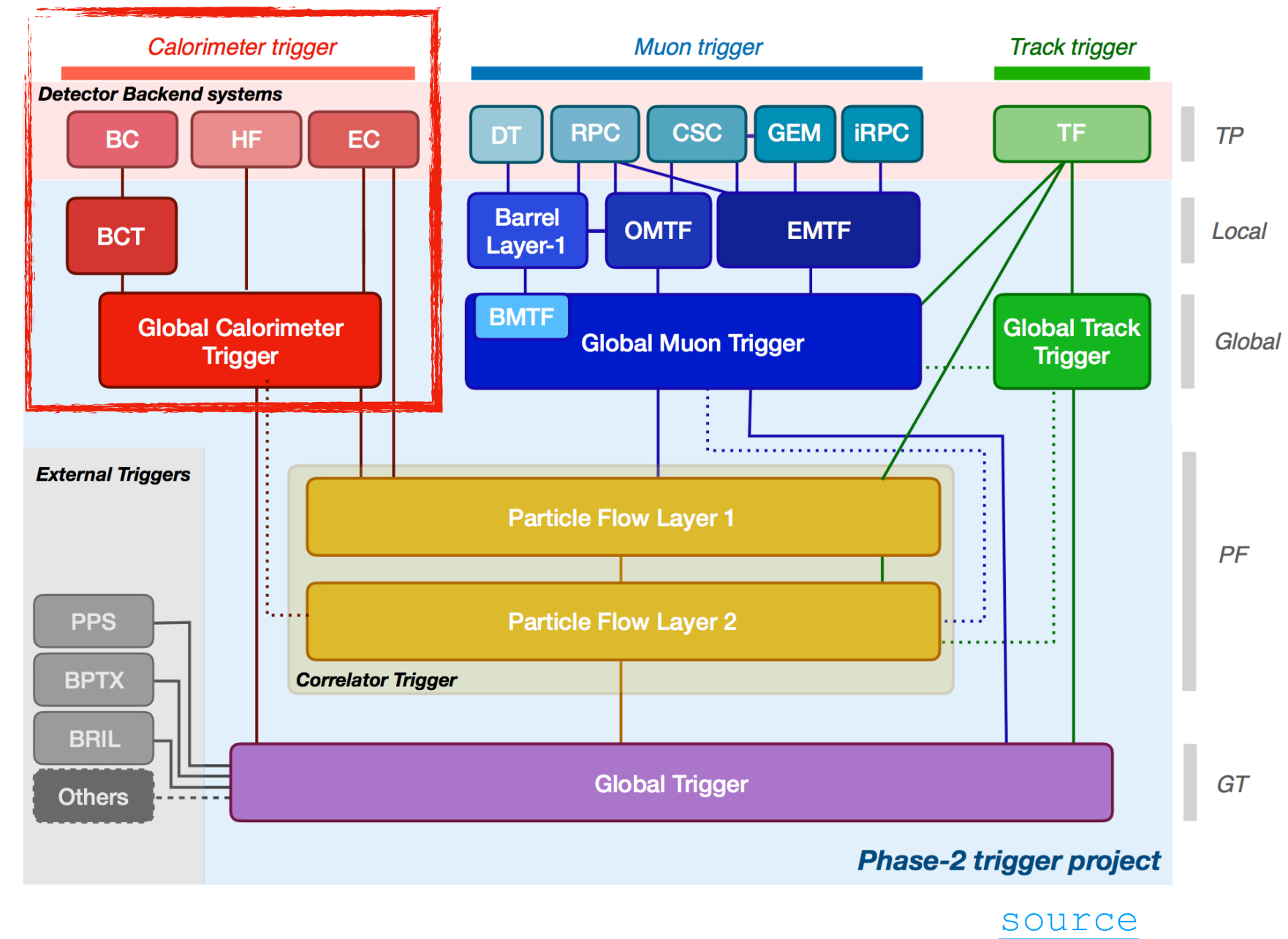

CMS Phase-2 Level-1 Trigger architecture

Calorimeter trigger

- * inclusion of the HGCal detector information
- * use of higher granularity (x25 in barrel ECAL)
- * production of high resolution clusters

reconstructs candidates from calo deposits

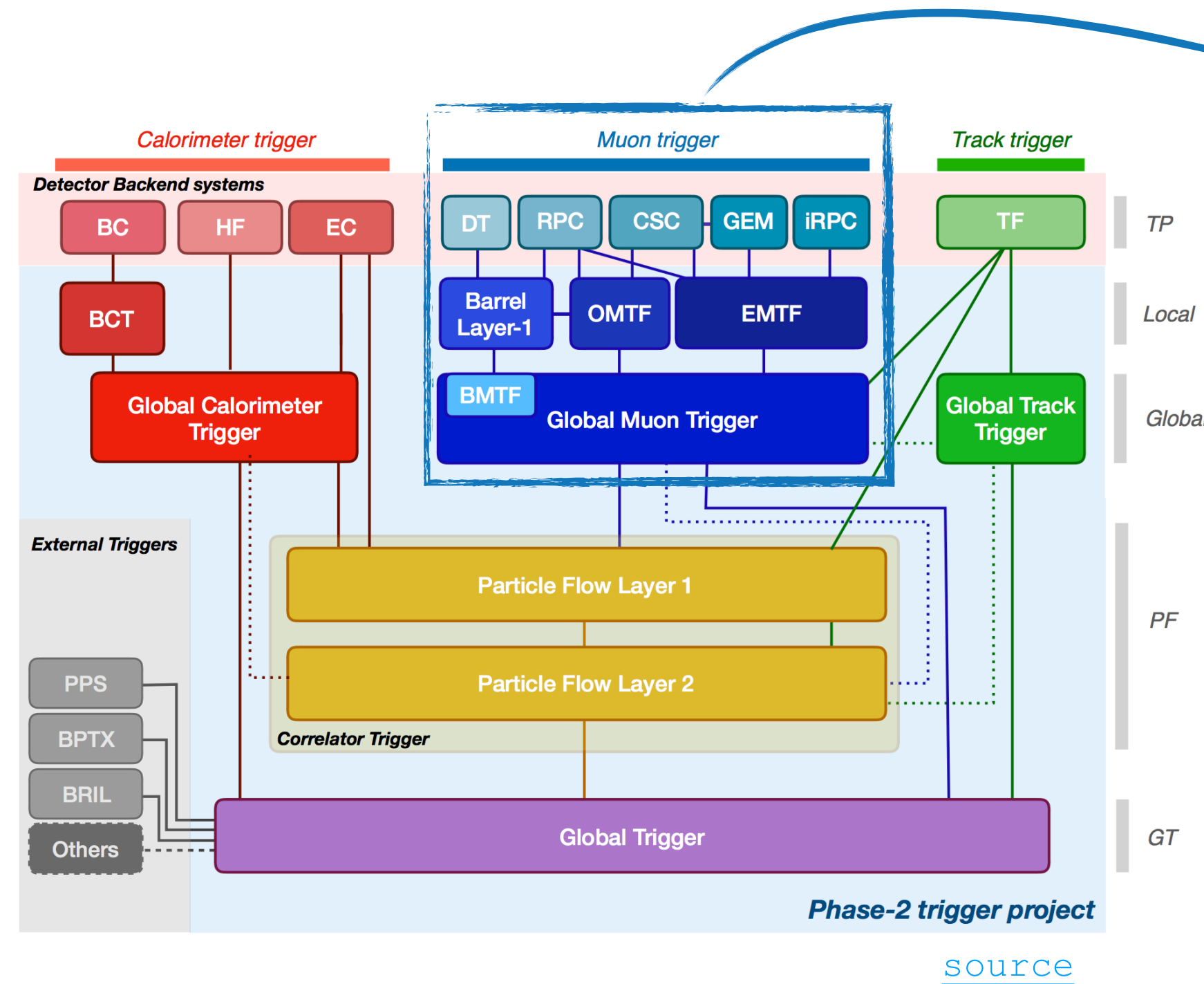

Muon trigger

- * three regions: barrel, endcap, overlap
- * η coverage extension: $2.4 < |\eta| < 2.8$
- * matching of muon candidates with tracks

reconstructs μ candidates

CMS Phase-2 Level-1 Trigger architecture

Calorimeter trigger

- * inclusion of the HGCAL detector information
- * use of higher granularity (x25 in barrel ECAL)
- * production of high resolution clusters

reconstructs candidates from calo deposits

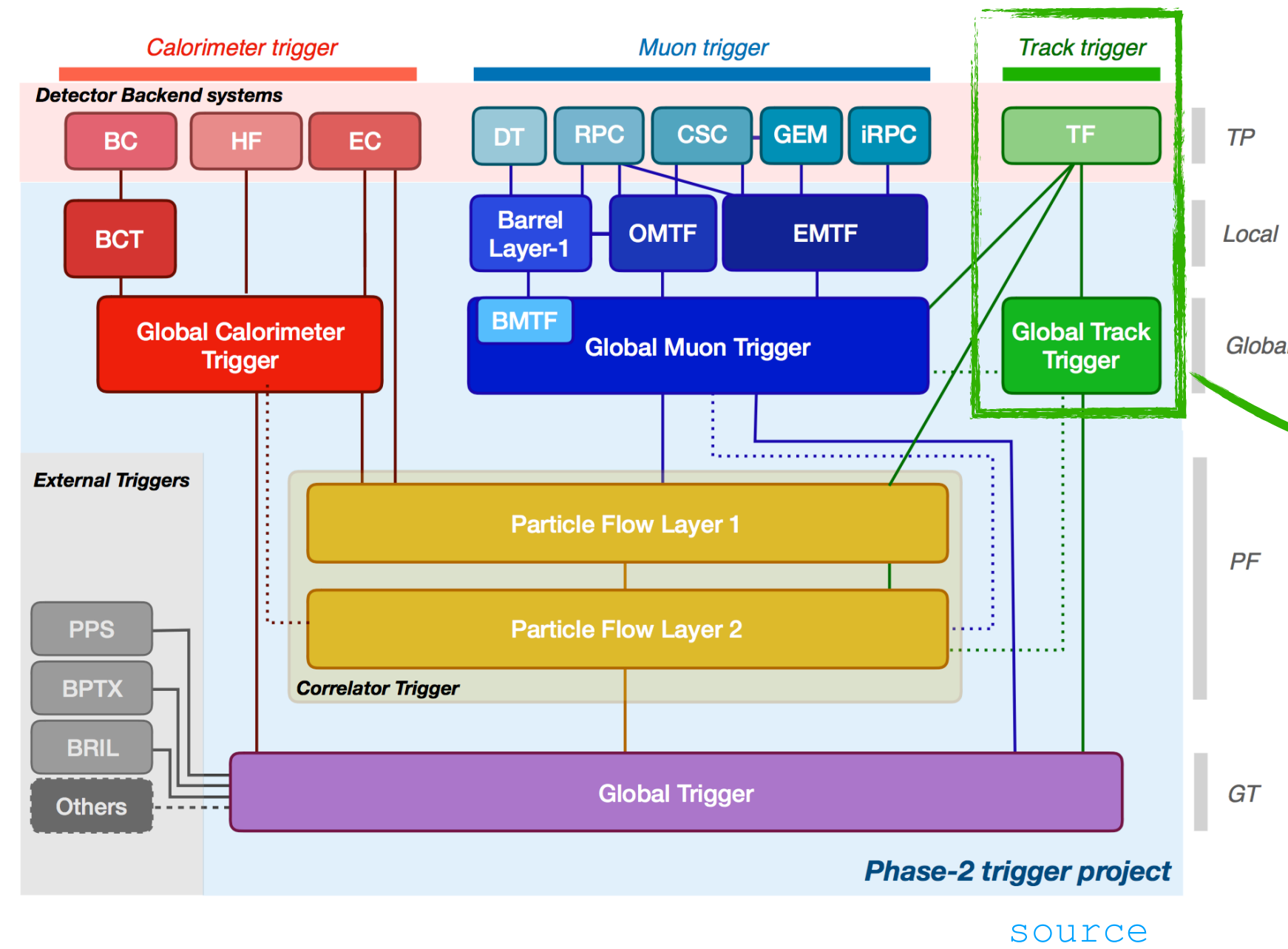

Muon trigger

- * three regions: barrel, endcap, overlap
- * η coverage extension: $2.4 < |\eta| < 2.8$
- * matching of muon candidates with tracks

reconstructs μ candidates

Track trigger

- * first ever inclusion of tracks at L1 trigger
- * precise vertex reconstruction
- * reconstruct light resonances, displaced isolated tracks, displaced jets

reconstructs charged particle candidate

CMS Phase-2 Level-1 Trigger architecture

Calorimeter trigger

- * inclusion of the HGCal detector information
- * use of higher granularity (x25 in barrel ECAL)
- * production of high resolution clusters

reconstructs candidates from calo deposits

Particle Flow trigger (aka Correlator Trigger)

- * match tracks to Calo and Muon objects
- * Layer 1 produces the particle flow and PUPPI (slide 16) candidates
- * Layer 2 builds and sorts the final trigger objects

reconstructs higher level variables and objects

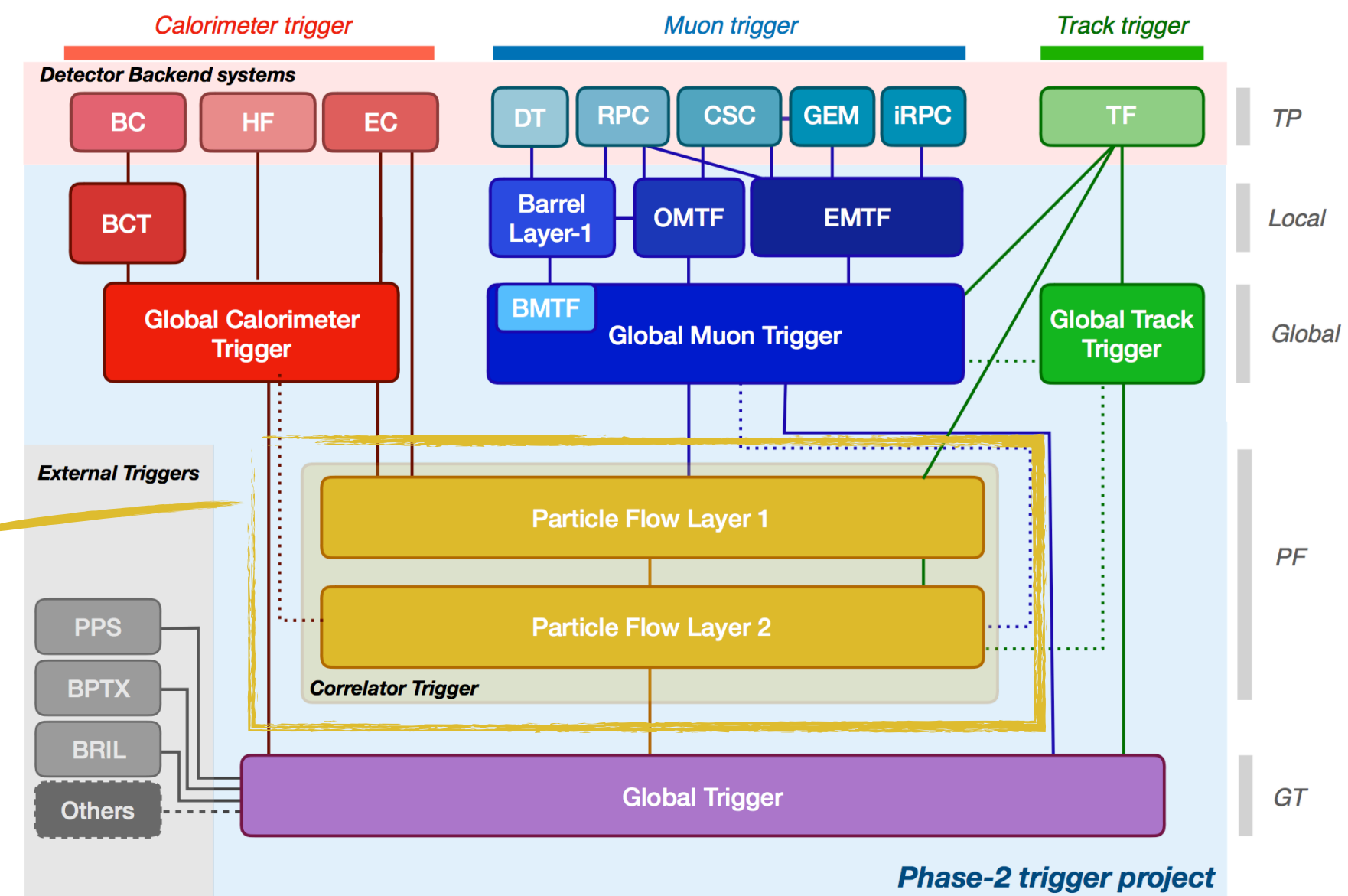

Muon trigger

- * three regions: barrel, endcap, overlap
- * η coverage extension: $2.4 < |\eta| < 2.8$
- * matching of muon candidates with tracks

reconstructs μ candidates

Track trigger

- * first ever inclusion of tracks at L1 trigger
- * precise vertex reconstruction
- * reconstruct light resonances, displaced isolated tracks, displaced jets

reconstructs charged particle candidate

CMS Phase-2 Level-1 Trigger architecture

Calorimeter trigger

- * inclusion of the HGCal detector information
- * use of higher granularity (x25 in barrel ECAL)
- * production of high resolution clusters

reconstructs candidates from calo deposits

Particle Flow trigger (aka Correlator Trigger)

- * match tracks to Calo and Muon objects
- * Layer 1 produces the particle flow and PUPPI (slide 16) candidates
- * Layer 2 builds and sorts the final trigger objects

reconstructs higher level variables and objects

Global trigger

- * combine the outputs of all the triggers
- * evaluate sophisticated correlation variables
- * provide interface with external triggers
- * implement the **L1physics menu: trigger algorithms (single/multi-objects trigger)**

calculates final decision

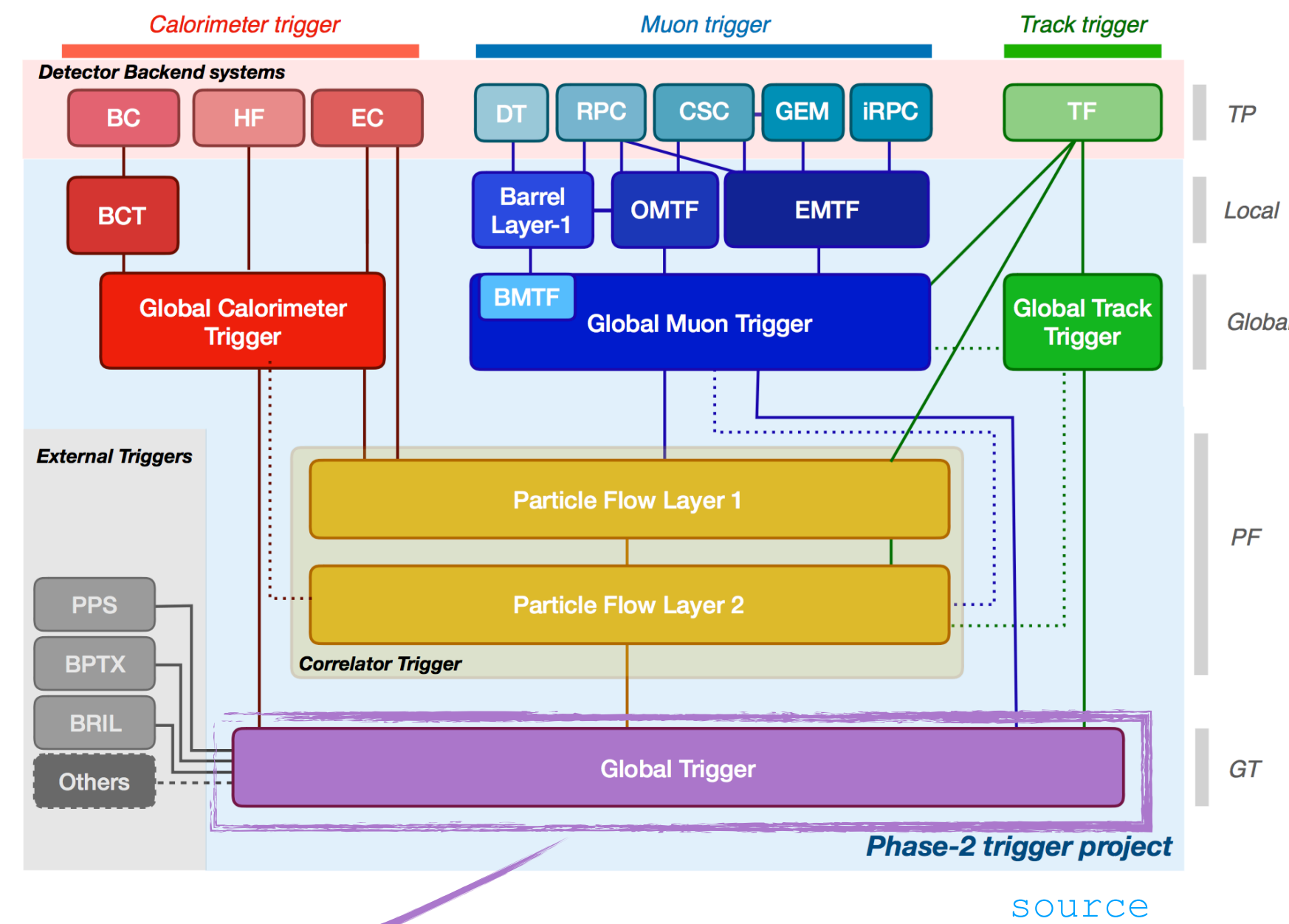

Muon trigger

- * three regions: barrel, endcap, overlap
- * η coverage extension: $2.4 < |\eta| < 2.8$
- * matching of muon candidates with tracks

reconstructs μ candidates

Track trigger

- * first ever inclusion of tracks at L1 trigger
- * precise vertex reconstruction
- * reconstruct light resonances, displaced isolated tracks, displaced jets

reconstructs charged particle candidate

[source](#)

CMS Phase-2 Level-1 Trigger architecture

Calorimeter trigger

- * inclusion of the HGCal detector information
- * use of higher granularity (x25 in barrel ECAL)
- * production of high resolution clusters

reconstructs candidates from calo deposits

Particle Flow trigger (aka Correlator Trigger)

- * match tracks to Calo and Muon objects
- * Layer 1 produces the particle flow and PUPPI (slide 16) candidates
- * Layer 2 builds and sorts the final trigger objects

reconstructs higher level variables and objects

Global trigger

- * combine the outputs of all the triggers
- * evaluate sophisticated correlation variables
- * provide interface with external triggers
- * implement the **L1physics menu: trigger algorithms (single/multi-objects trigger)**

calculates final decision

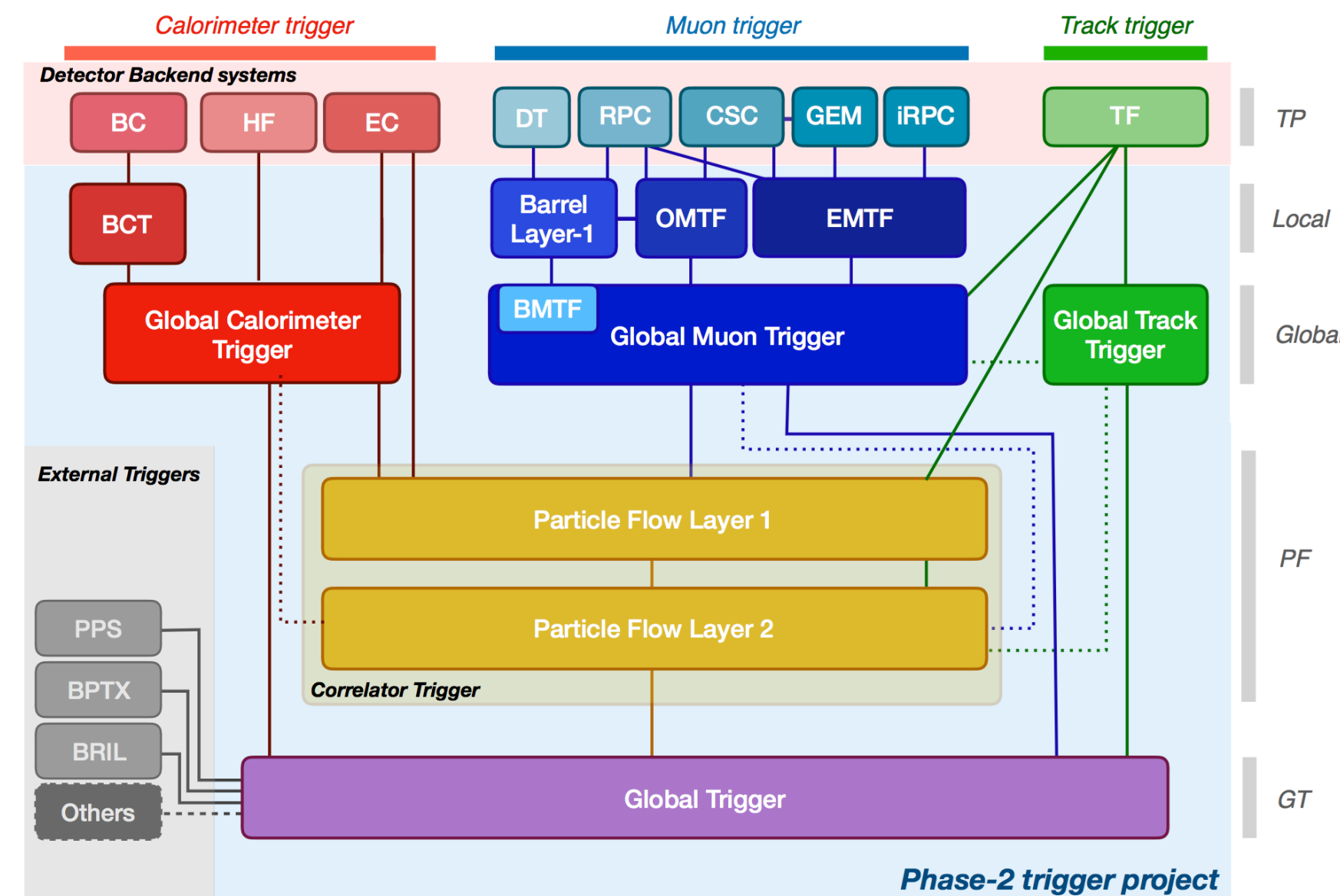

Muon trigger

- * three regions: barrel, endcap, overlap
- * η coverage extension: $2.4 < |\eta| < 2.8$
- * matching of muon candidates with tracks

reconstructs μ candidates

Track trigger

- * first ever inclusion of tracks at L1 trigger
- * precise vertex reconstruction
- * reconstruct light resonances, displaced isolated tracks, displaced jets

reconstructs charged particle candidate

40MHz Scouting System

- * enable trigger-less analysis at collision rate
- * work with a subset of the triggers info
- * use processing boards' spare optical outputs
- * perform live diagnostics of the trigger system

targets bunch crossing rate analysis

CMS Phase-2 Level-1 Trigger architecture

Calorimeter trigger

- * inclusion of the HGCal detector information
- * use of higher granularity (x25 in barrel ECAL)
- * production of high resolution clusters

reconstructs candidates from calo deposits

Particle Flow trigger (aka Correlator Trigger)

- * match tracks to Calo and Muon objects
- * Layer 1 produces the particle flow and PUPPI (slide 16) candidates
- * Layer 2 builds and sorts the final trigger objects

reconstructs higher level variables and objects

Global trigger

- * combine the outputs of all the triggers
- * evaluate sophisticated correlation variables
- * provide interface with external triggers
- * implement the **L1physics menu: trigger algorithms (single/multi-objects trigger)**

calculates final decision

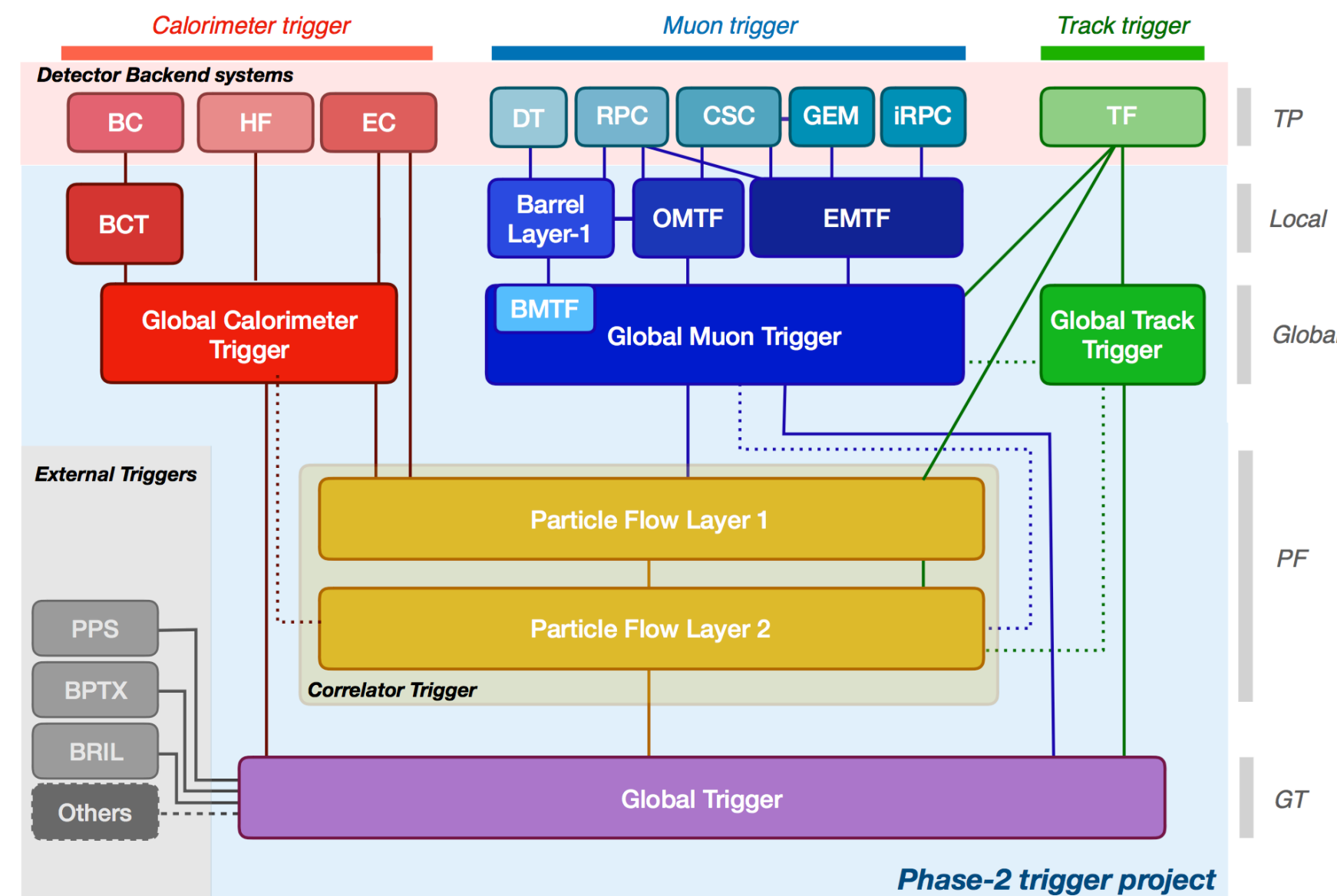

Muon trigger

- * three regions: barrel, endcap, overlap
- * η coverage extension: $2.4 < |\eta| < 2.8$
- * matching of muon candidates with tracks

reconstructs μ candidates

Track trigger

- * first ever inclusion of tracks at L1 trigger
- * precise vertex reconstruction
- * reconstruct light resonances, displaced isolated tracks, displaced jets

reconstructs charged particle candidate

40MHz Scouting System

- * enable trigger-less analysis at collision rate
- * work with a subset of the triggers info
- * use processing boards' spare optical outputs
- * perform live diagnostics of the trigger system

targets bunch crossing rate analysis

⇒ this L1 Trigger architecture is capable of **Global Event Reconstruction** closer to the offline performance moving the trigger capabilities towards a **"Real-Time analysis"**

Preserving the discovery potential...

- ...with single-lepton trigger algorithms
- ...with double- γ trigger algorithms
- ...with double- τ trigger algorithms
- ...with multi-jet trigger algorithms

...with single-lepton trigger algorithms

Preserving Phase-1 lepton L1-thresholds with track information

The role of tracks for the lepton algorithms is threefold:

- * they are **matched to the calorimeter deposits** to help in the identification of the e candidates
- * they are **matched to the muon detectors hits** to help in the identification of the μ candidates
- * they are **used to define an isolation variable** for both e and μ candidates

Using the tracks at L1 Trigger guarantees to set thresholds on e/μ as low as those used during Phase-1

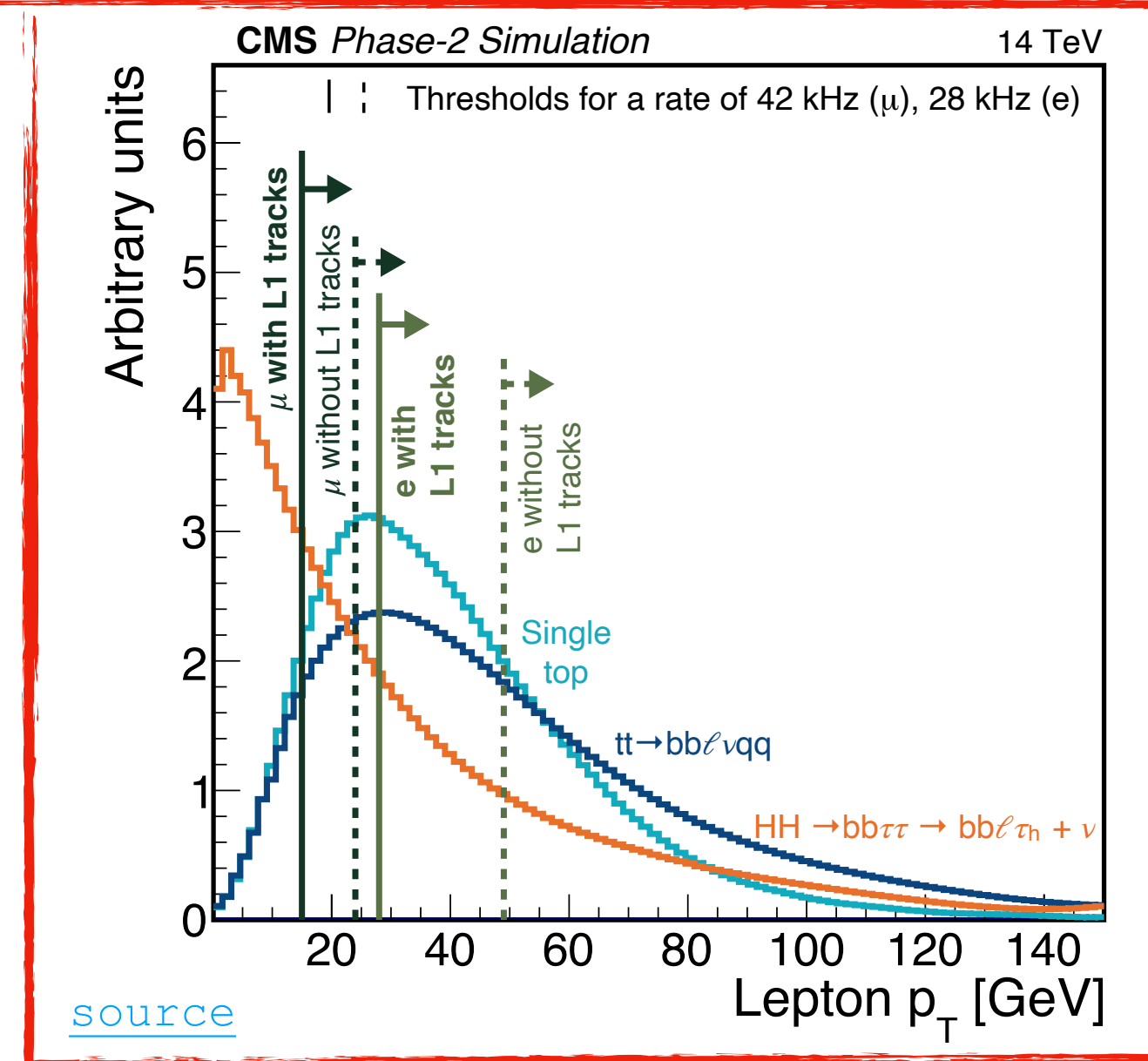

...with single-lepton trigger algorithms

Preserving Phase-1 lepton L1-thresholds with track information

The role of tracks for the lepton algorithms is threefold:

- * they are **matched to the calorimeter deposits** to help in the identification of the e candidates
- * they are **matched to the muon detectors hits** to help in the identification of the μ candidates
- * they are **used to define an isolation variable** for both e and μ candidates

Using the tracks at L1 Trigger guarantees to set thresholds on e/ μ as low as those used during Phase-1

Differential $tt \rightarrow bbl\nu qq$

- Important test of SM, EWSB, and BSM
- Important bkg for many other analysis
- η -differential studies accessible during Phase-2

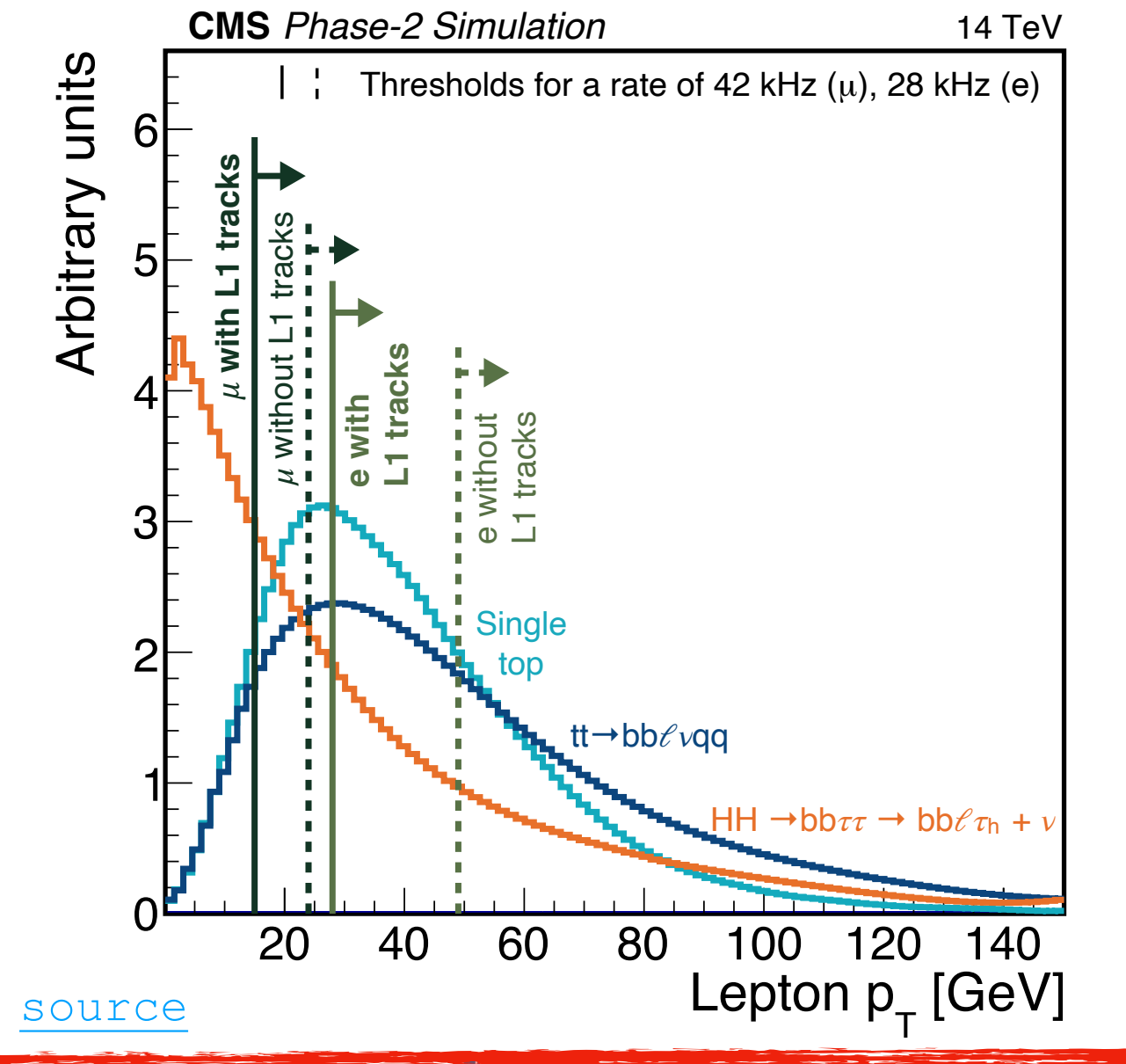
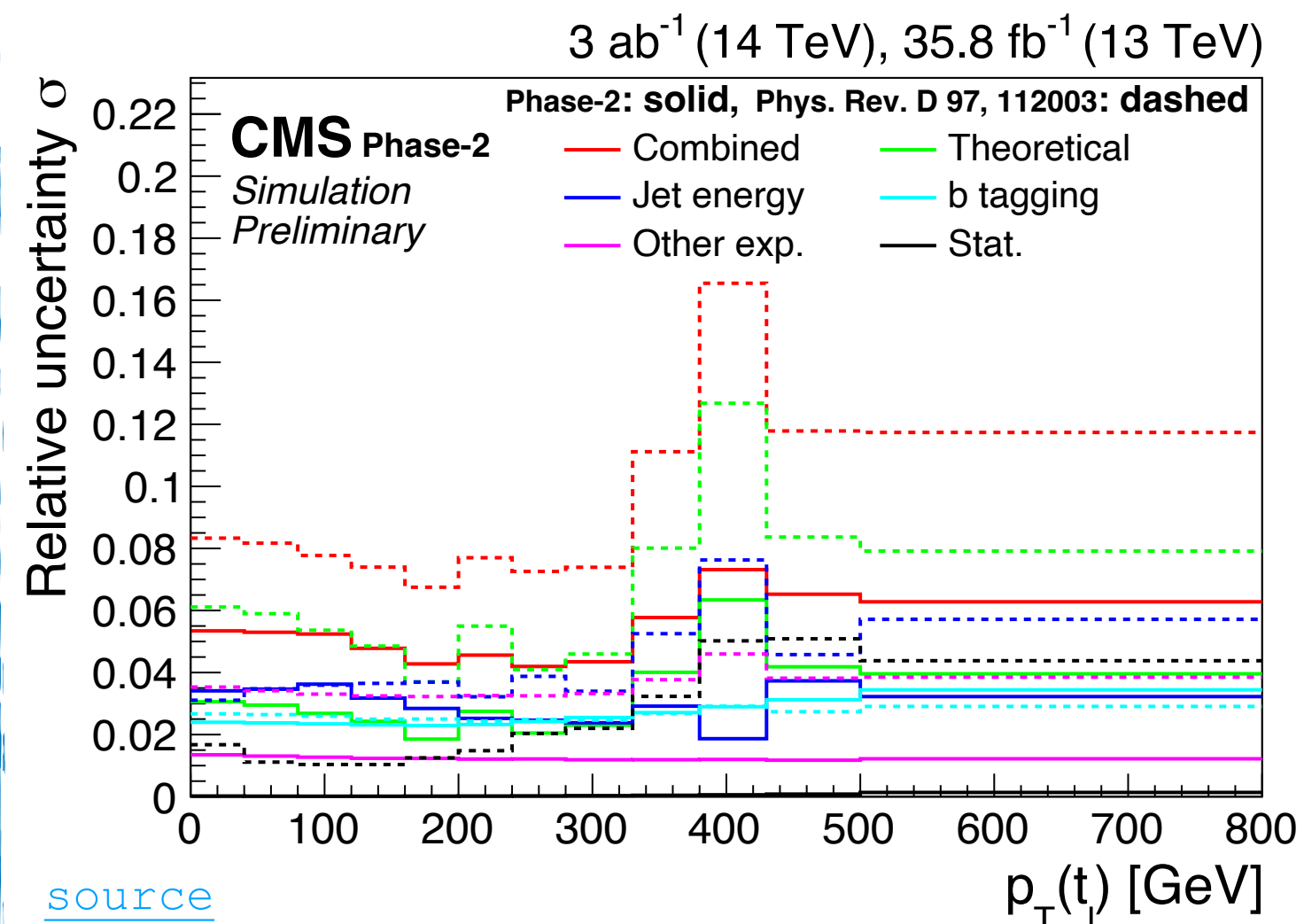

\Rightarrow x1.5 improvement compared to 2016

...with single-lepton trigger algorithms

Preserving Phase-1 lepton L1-thresholds with track information

The role of tracks for the lepton algorithms is threefold:

- * they are **matched to the calorimeter deposits** to help in the identification of the e candidates
- * they are **matched to the muon detectors hits** to help in the identification of the μ candidates
- * they are **used to define an isolation variable** for both e and μ candidates

Using the tracks at L1 Trigger guarantees to set thresholds on e/ μ as low as those used during Phase-1

Differential $tt \rightarrow bbl\nu qq$

- Important test of SM, EWSB, and BSM
- Important bkg for many other analysis
- η -differential studies accessible during Phase-2

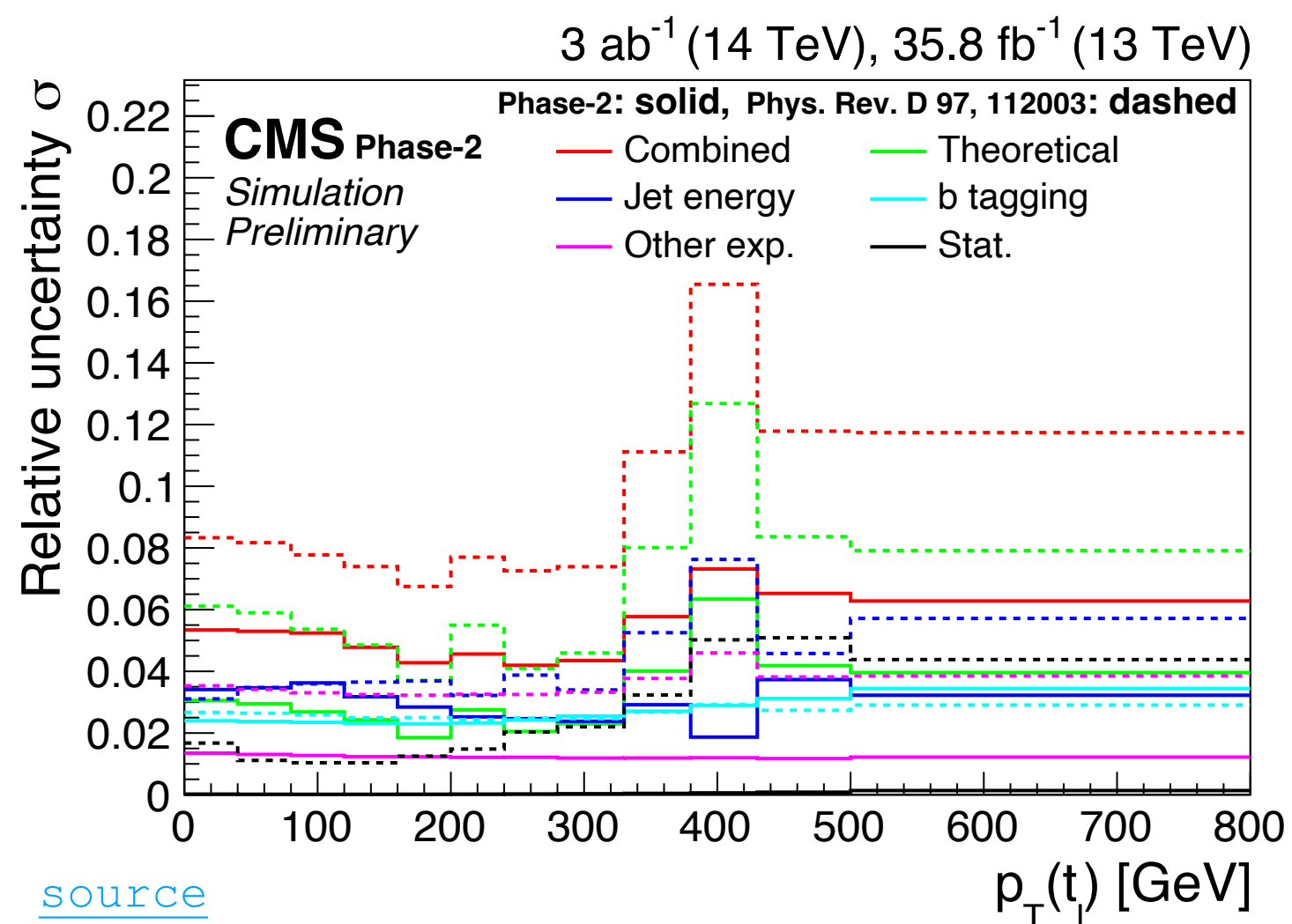

⇒ x1.5 improvement compared to 2016

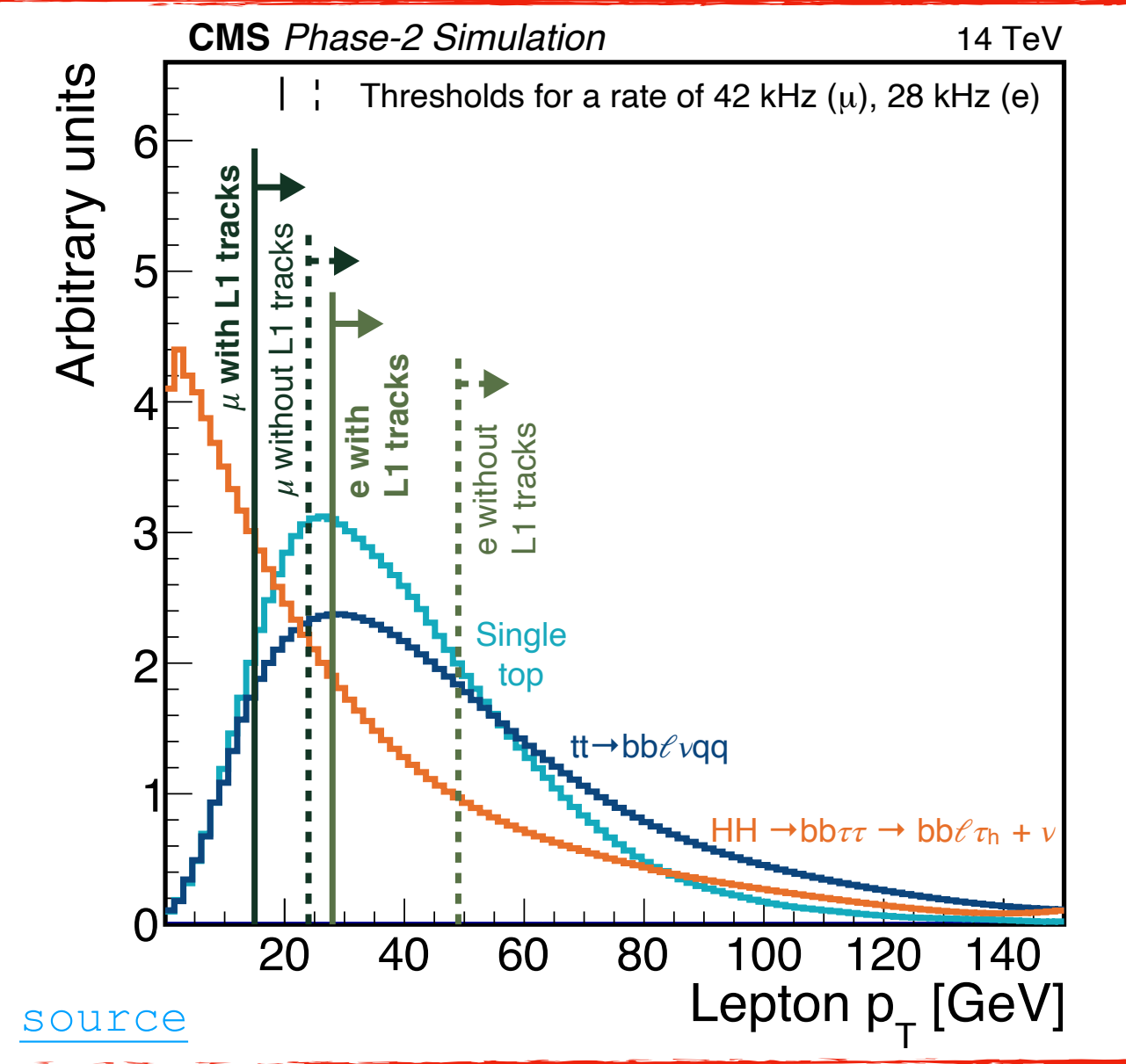

⇒ x2 improvement compared to Run2

tttt in leptonic final states

- Rare SM process used to constrain magnitude and CP properties of top Yukawa coupling, and to probe BSM scenarios (2HDM and DM)
- Evidence possible already at 300fb⁻¹

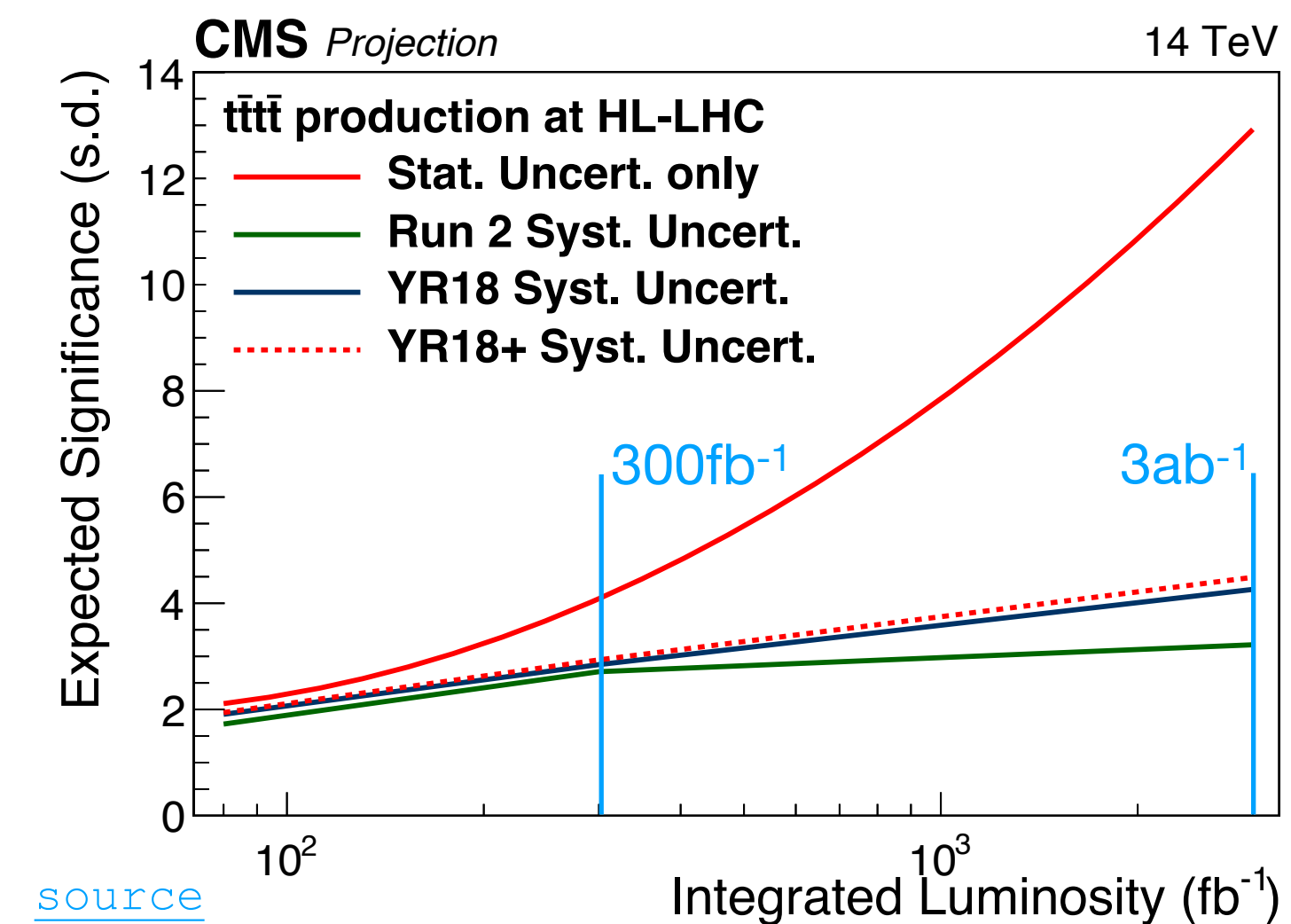

...with double- γ trigger algorithms

Preserving Phase-1 photon L1-thresholds with track information

The role of tracks for the photon algorithms is that they are **used to define an isolation variable**: a photon is identified as an isolated standalone calorimeter objects satisfying the calorimeter-based γ ID for barrel and endcap, and the **track-based isolation cut ($|\eta| < 2.4$)** is enforced on the candidate

Using the tracks at L1 Trigger guarantees to set thresholds on γ as low as those used during Phase-1

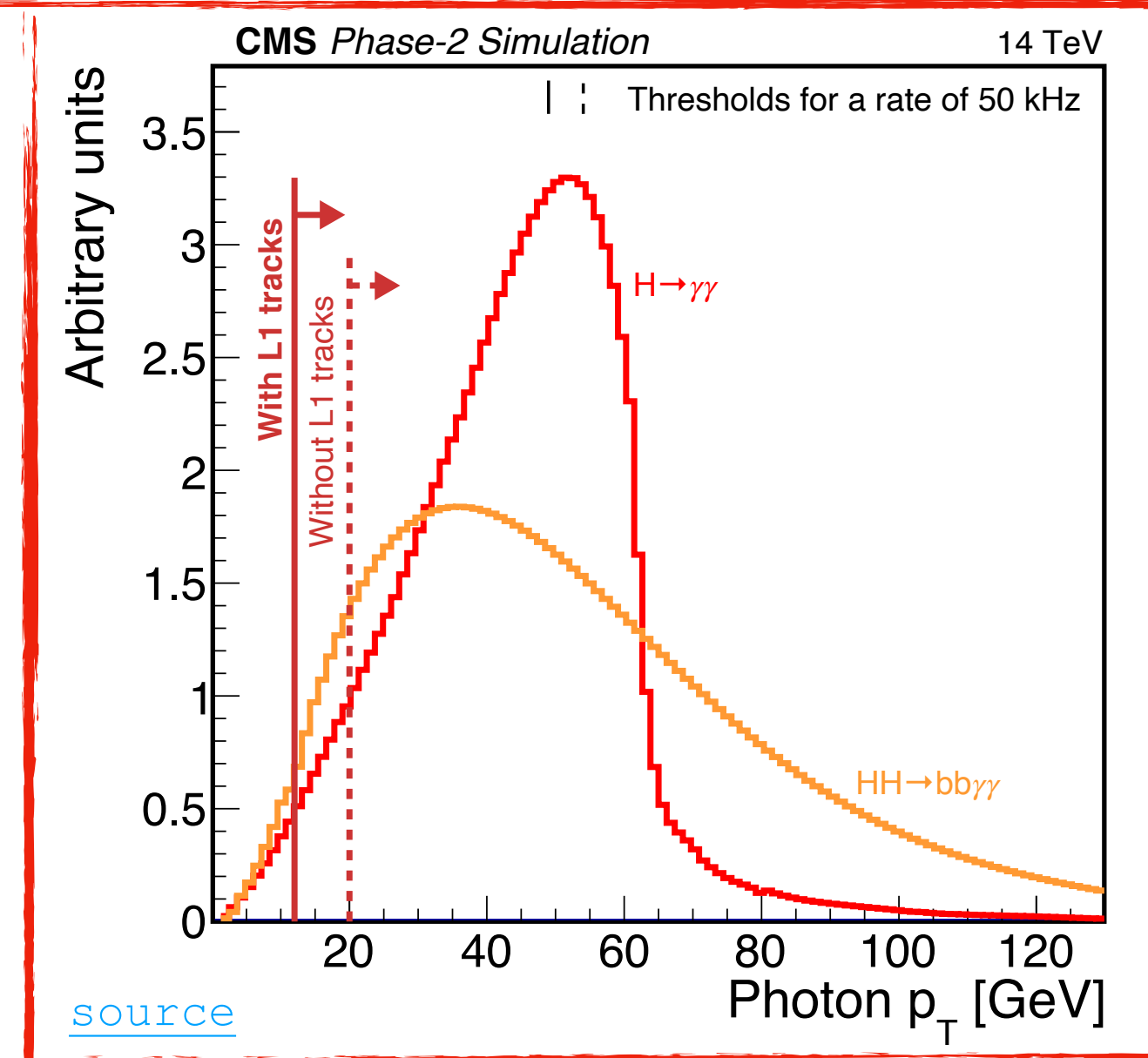

...with double- γ trigger algorithms

Preserving Phase-1 photon L1-thresholds with track information

The role of tracks for the photon algorithms is that they are **used to define an isolation variable**: a photon is identified as an isolated standalone calorimeter objects satisfying the calorimeter-based γ ID for barrel and endcap, and the **track-based isolation cut ($|\eta| < 2.4$)** is enforced on the candidate

Using the tracks at L1 Trigger guarantees to set thresholds on γ as low as those used during Phase-1

$HH \rightarrow bb\gamma\gamma$

- $bb\gamma\gamma$ final state among most sensitive
- Upper limit @ 95% CL = 1.09 x SM
- Significance of HH signal 1.85 σ

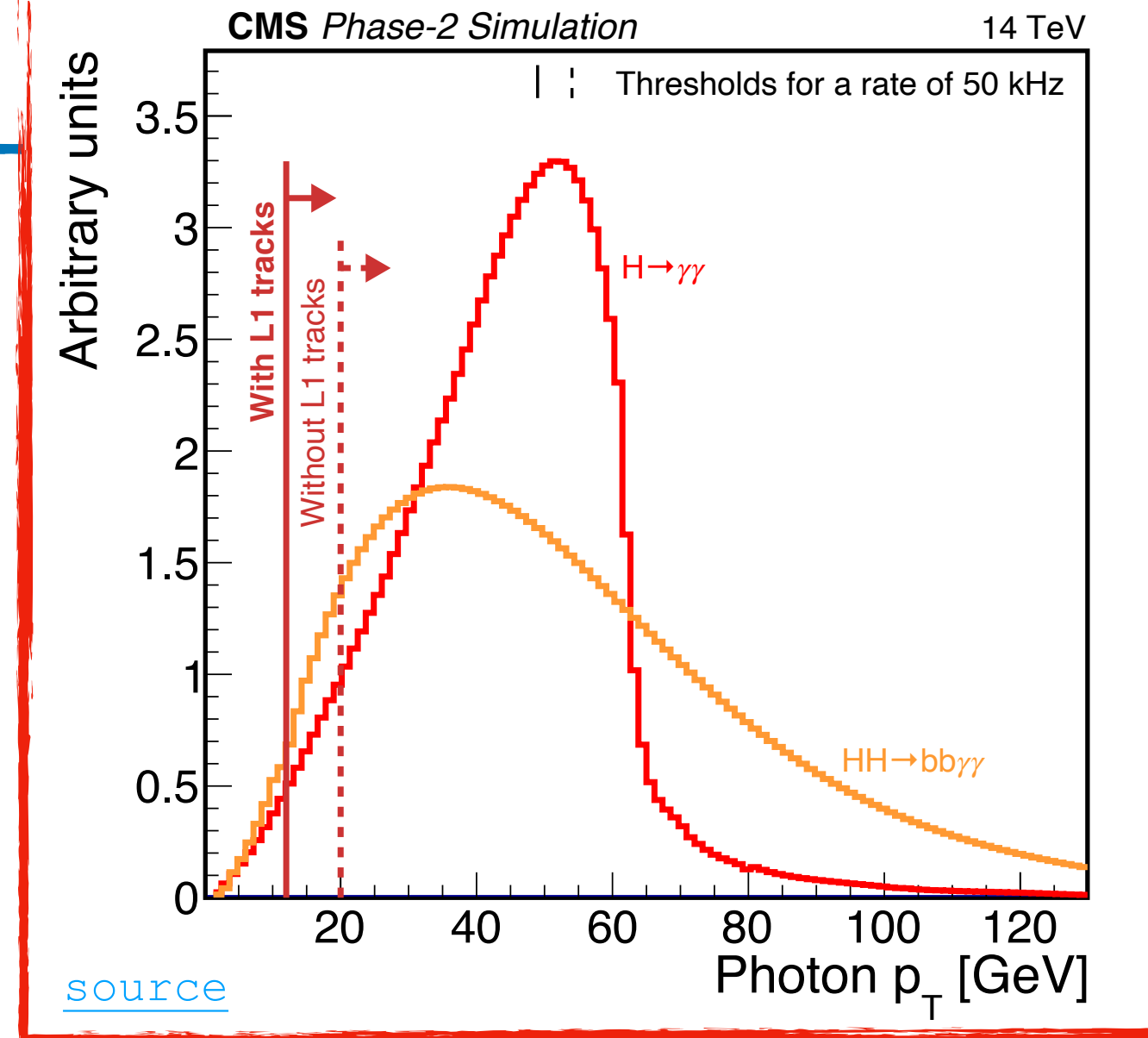
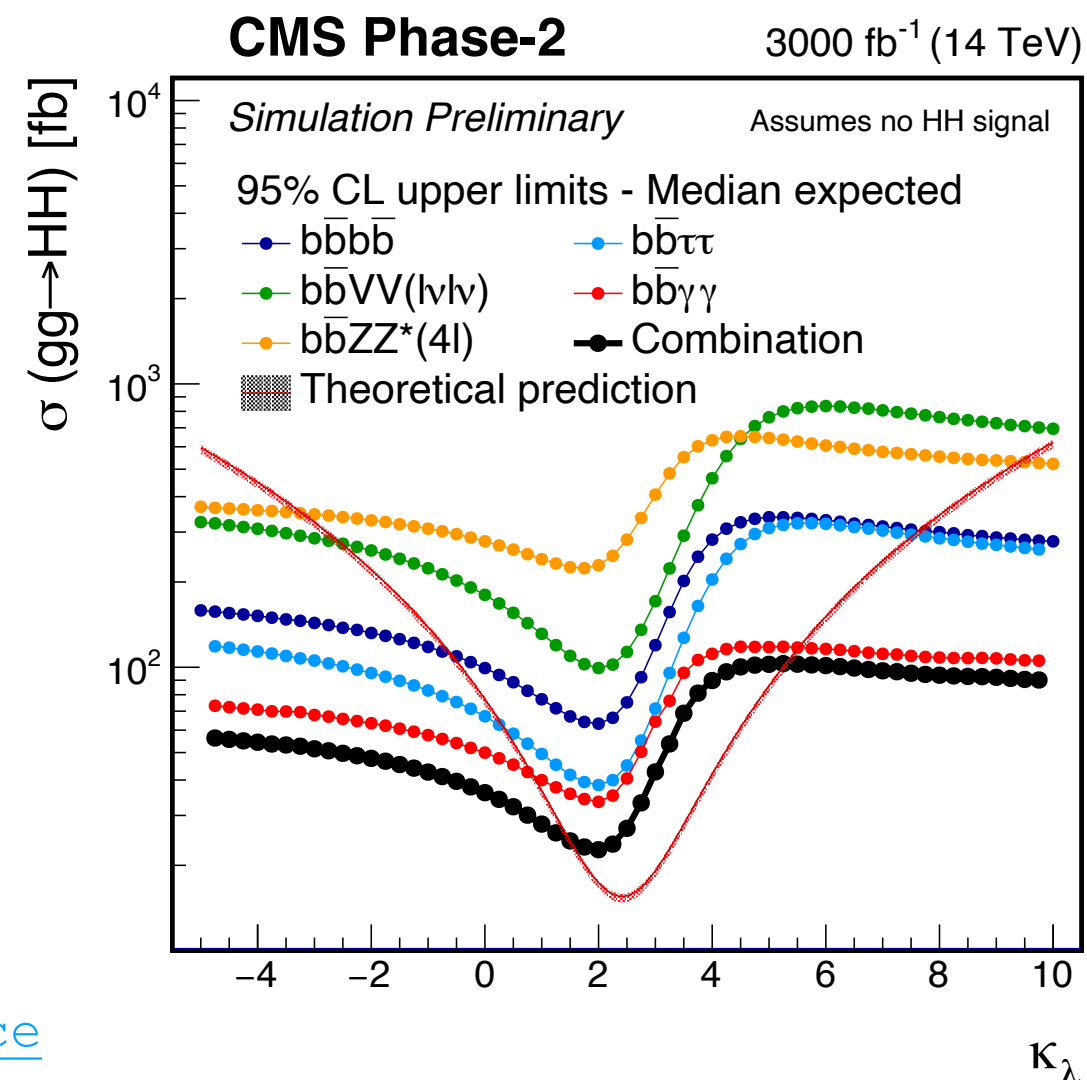

\Rightarrow x7 improvement compared to Run2

...with double- γ trigger algorithms

Preserving Phase-1 photon L1-thresholds with track information

The role of tracks for the photon algorithms is that they are **used to define an isolation variable**: a photon is identified as an isolated standalone calorimeter objects satisfying the calorimeter-based γ ID for barrel and endcap, and the **track-based isolation cut ($|\eta| < 2.4$)** is enforced on the candidate

Using the tracks at L1 Trigger guarantees to set thresholds on γ as low as those used during Phase-1

$HH \rightarrow b\bar{b}\gamma\gamma$

- $b\bar{b}\gamma\gamma$ final state among most sensitive
- Upper limit @ 95% CL = 1.09 x SM
- Significance of HH signal 1.85σ

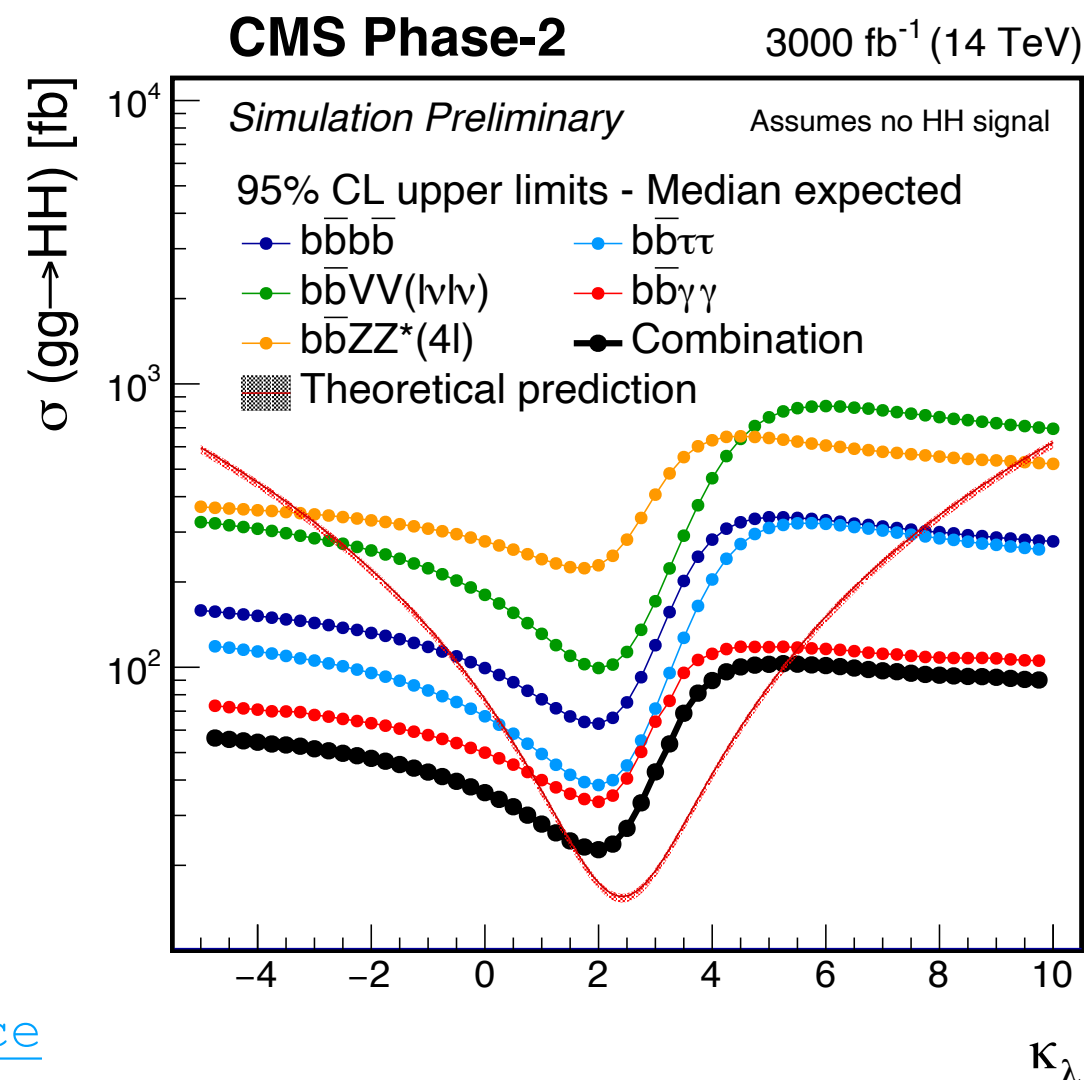

source

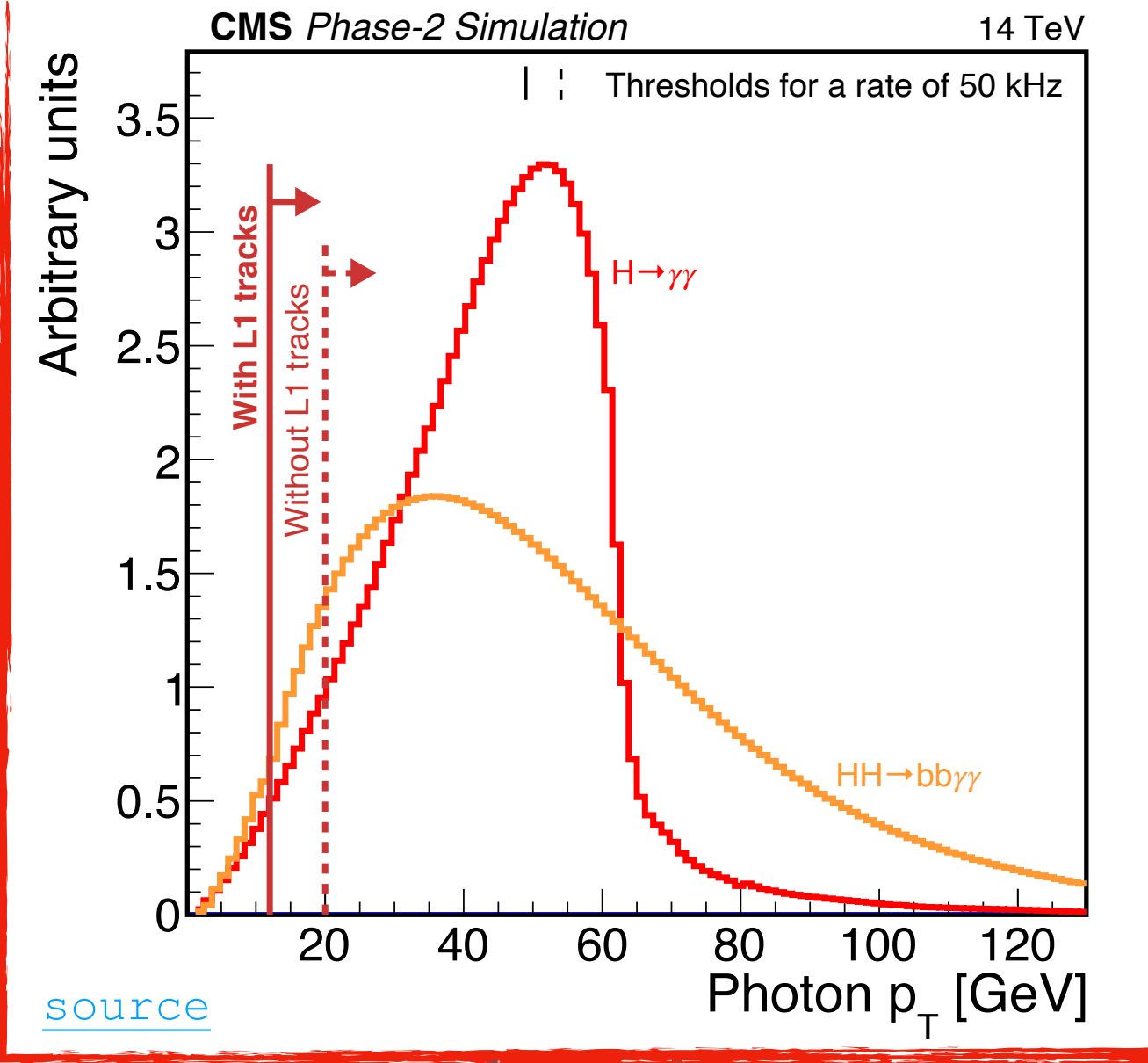

source

⇒ x7 improvement compared to Run2

⇒ would be the first ever measurement of this kind

λ_{HHH} constraints from $t\bar{t}H+tH$

- Radiative corrections to $t\bar{t}H$ and tH are indirect probe for λ_{HHH}
- Both inclusive and differential $\sigma(t\bar{t}H/tH)$

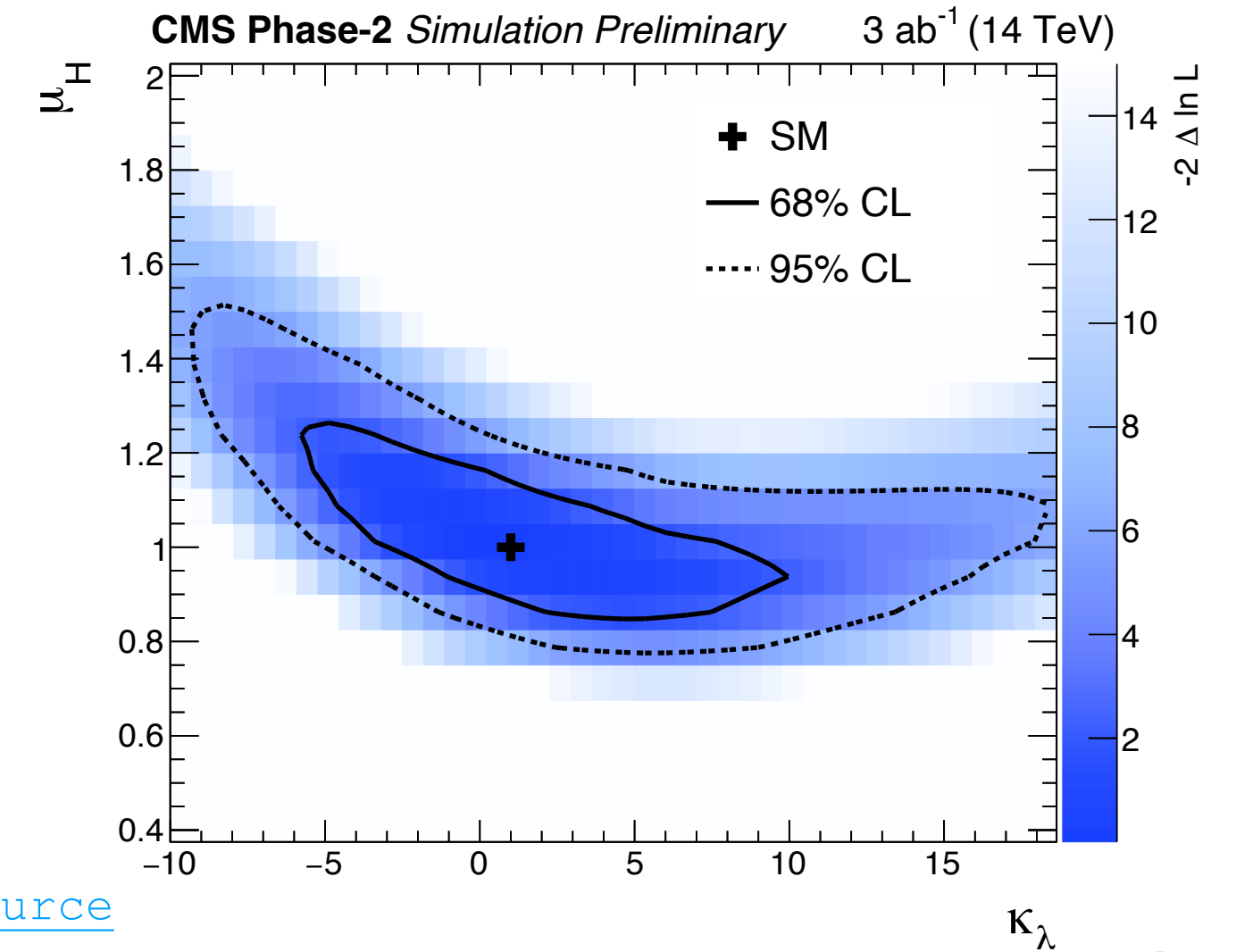

source

...with double- τ trigger algorithms

Preserving Phase-1 tau L1-thresholds with track information

Tau candidates are reconstructed at L1 Trigger with three different algorithms:

- * **tower-based algorithm** → reconstructs and isolates taus using rectangular and square mask over calorimeter towers
- * **HGCAL-based algorithm** → relies on multiple BDTs for the tasks of pileup rejection, τ recognition, and isolation
- * **tracker+calo algorithm** → matches the calorimeter deposits with the tracks of the hadronic decay products

Using the tracks at L1 Trigger guarantees to set thresholds on tau as low as those used during Phase-1
 The HGCAL-based algorithm complements the tracker-based algorithm to extend the coverage to $\eta < 3$

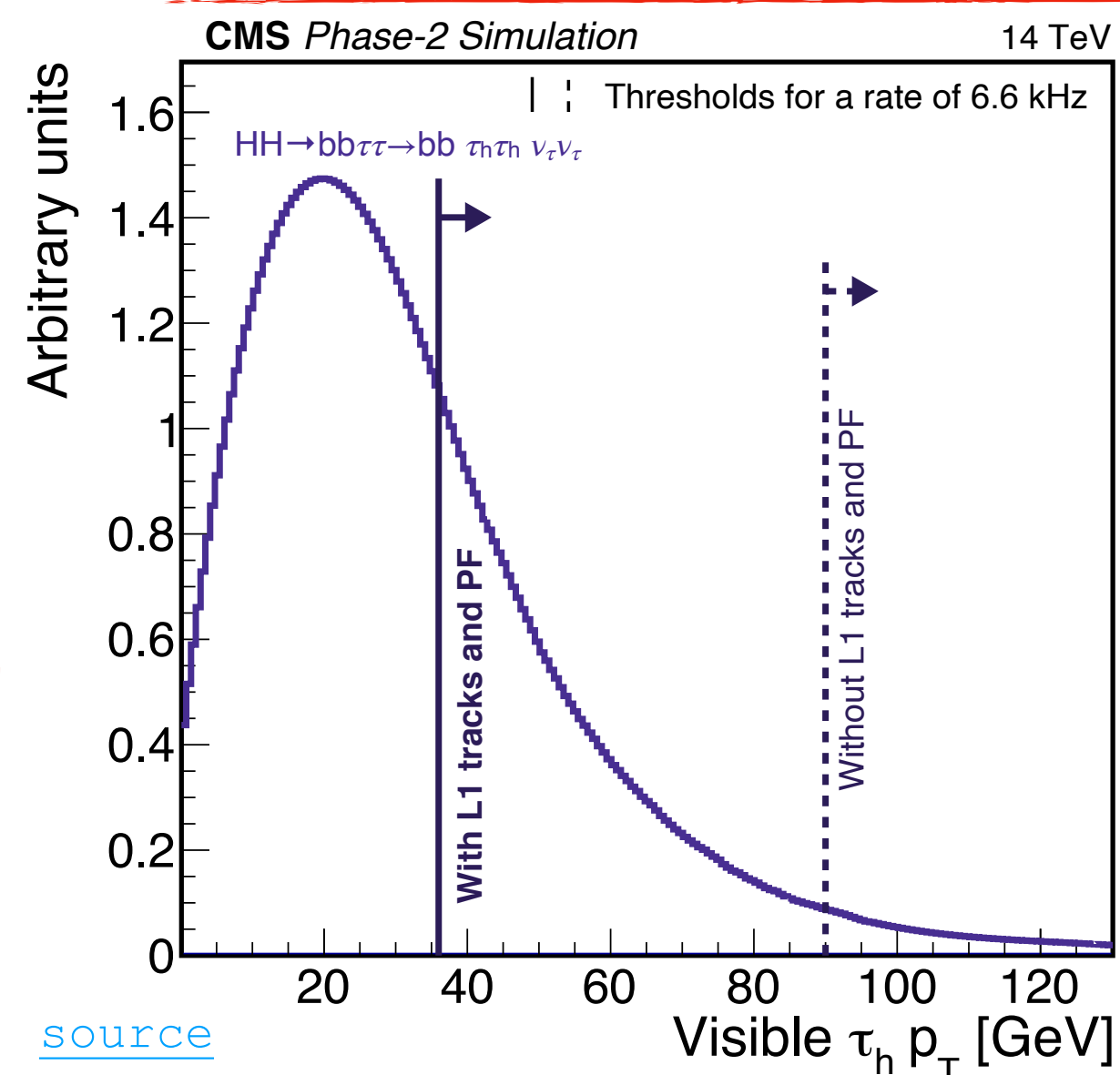

...with double- τ trigger algorithms

Preserving Phase-1 tau L1-thresholds with track information

Tau candidates are reconstructed at L1 Trigger with three different algorithms:

- * **tower-based algorithm** → reconstructs and isolates taus using rectangular and square mask over calorimeter towers
- * **HGCAL-based algorithm** → relies on multiple BDTs for the tasks of pileup rejection, τ recognition, and isolation
- * **tracker+calo algorithm** → matches the calorimeter deposits with the tracks of the hadronic decay products

Using the tracks at L1 Trigger guarantees to set thresholds on tau as low as those used during Phase-1
 The HGCAL-based algorithm complements the tracker-based algorithm to extend the coverage to $\eta < 3$

HH → bb $\tau\tau$

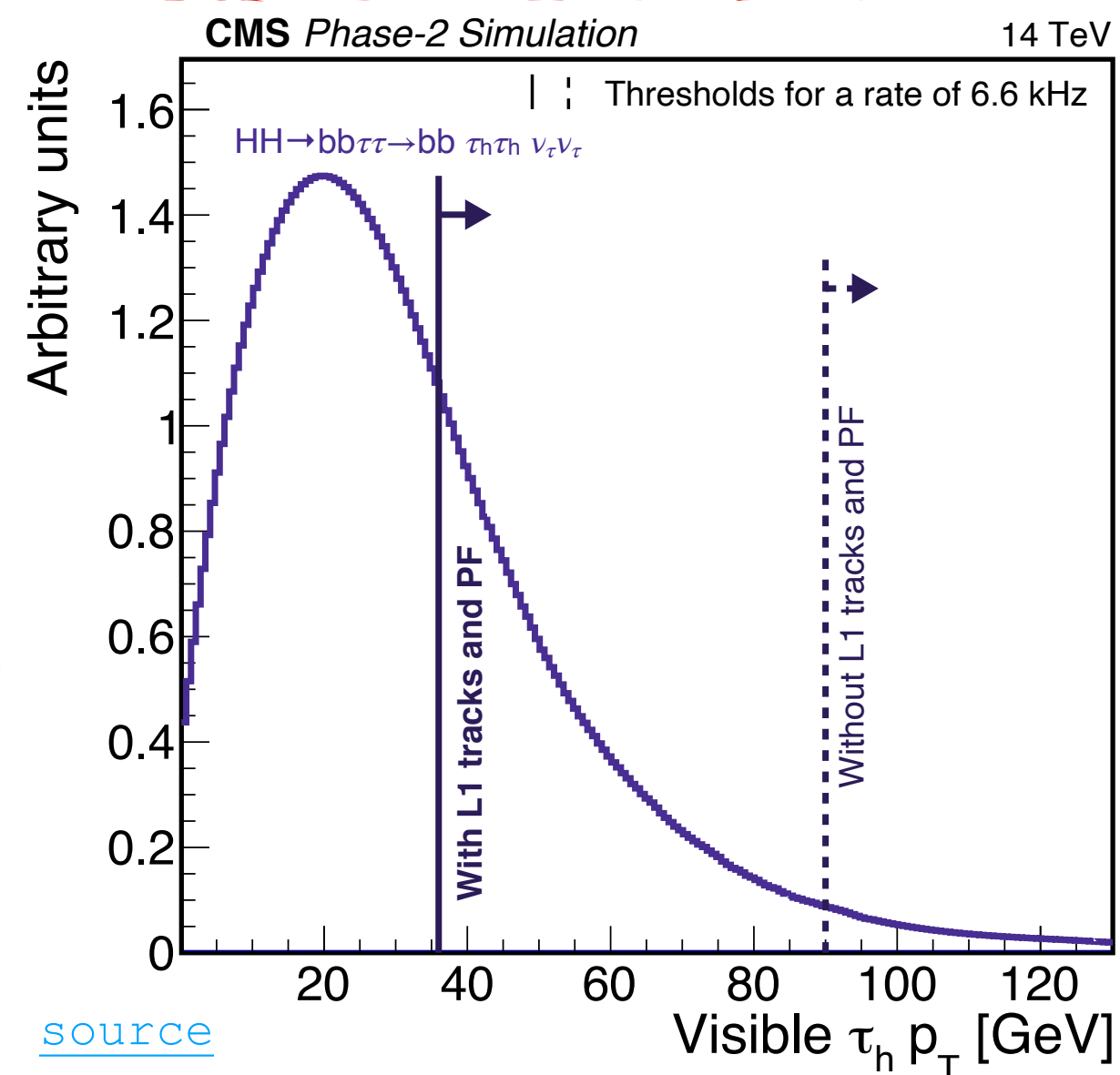

[source](#)

- bb $\tau\tau$ among most sensible final states (thanks to τ purity and bb large branching ratio)
- Pseudorapidity coverage extension central for increasing acceptance
- Upper limit @ 95% CL = **1.4 x SM**
- Significance of HH signal **1.4 σ**

⇒ **x30 improvement compared to 2016**
 (Run2 results not public yet)

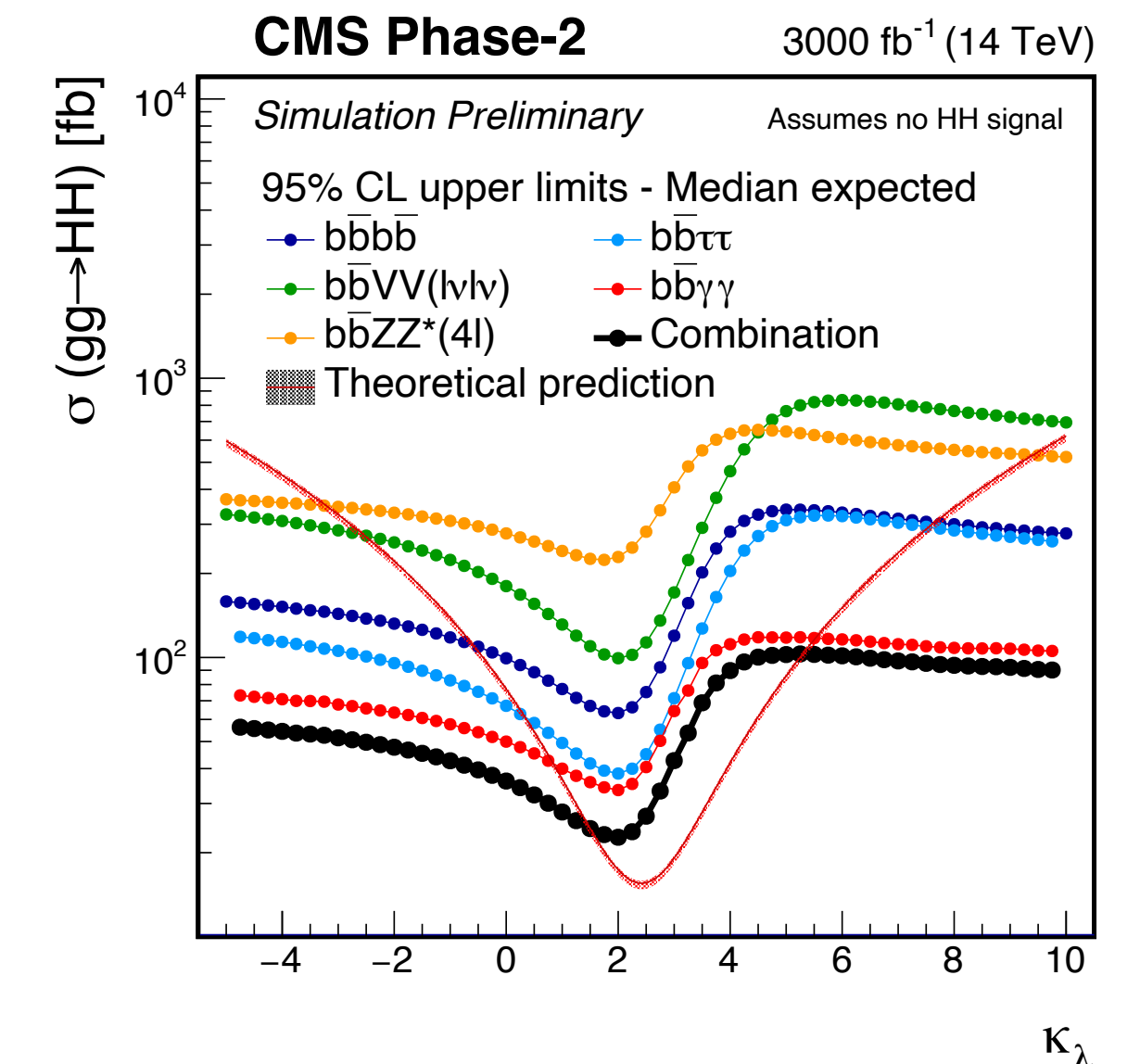

[source](#)

...with multi-jet trigger algorithms

Preserving Phase-1 jet L1-thresholds with track information

Jet candidates are reconstructed at L1 Trigger with three different algorithms:

- * **calorimeter-based algorithm** → builds jets using rectangular and square mask over calorimeter towers
- * **track-based algorithm** → builds jets based on tracks and clusters them with a nearest-neighbour approach
- * **particle-flow algorithm** → builds jets based on PUPPI candidates ([slide 16](#)) and clusters them with fixed dimension windows

Using the tracks at L1 Trigger guarantees to set thresholds on jets as low as those used during Phase-1

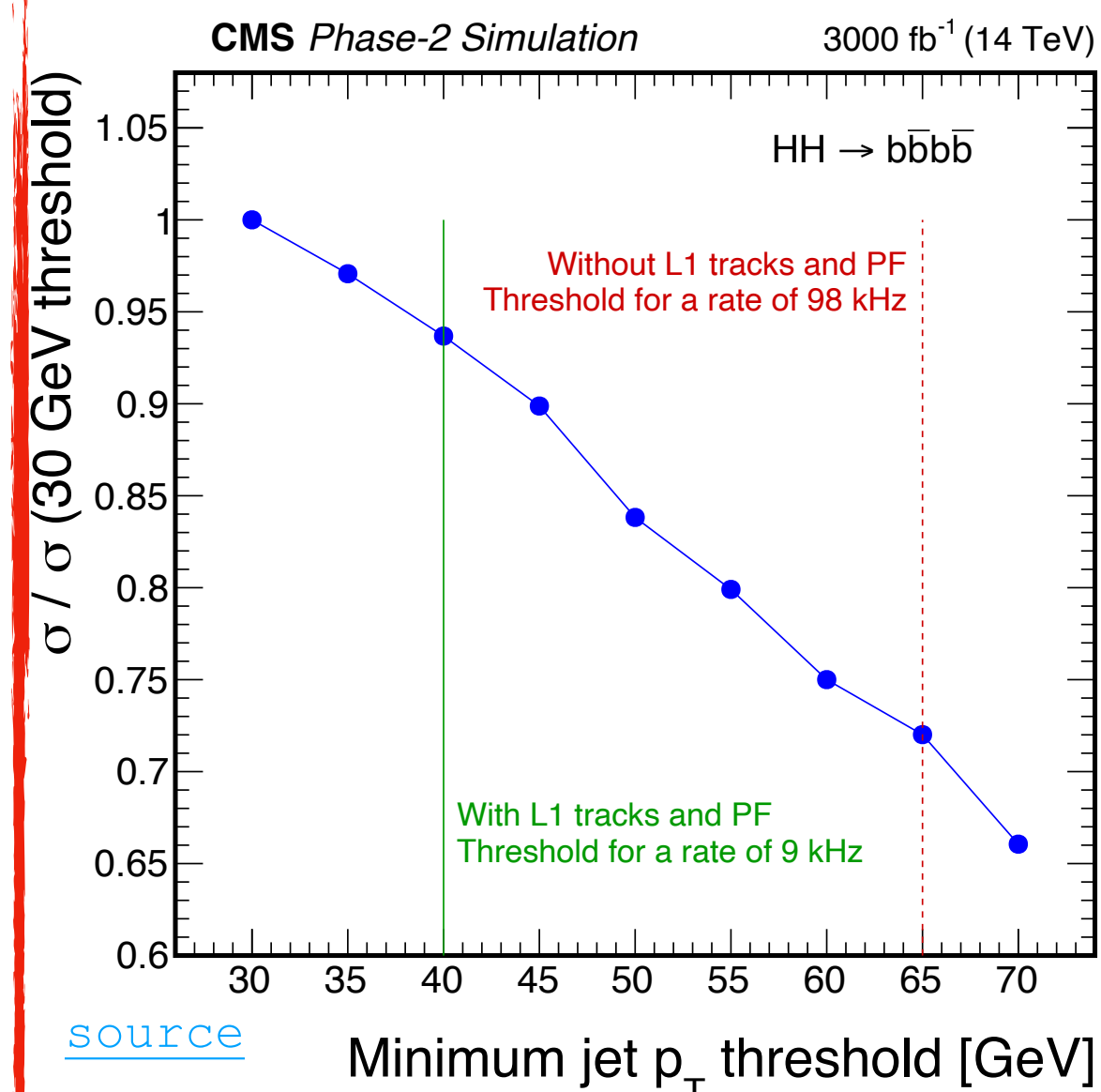

...with multi-jet trigger algorithms

Preserving Phase-1 jet L1-thresholds with track information

Jet candidates are reconstructed at L1 Trigger with three different algorithms:

- * **calorimeter-based algorithm** → builds jets using rectangular and square mask over calorimeter towers
- * **track-based algorithm** → builds jets based on tracks and clusters them with a nearest-neighbour approach
- * **particle-flow algorithm** → builds jets based on PUPPI candidates ([slide 16](#)) and clusters them with fixed dimension windows

Using the tracks at L1 Trigger guarantees to set thresholds on jets as low as those used during Phase-1

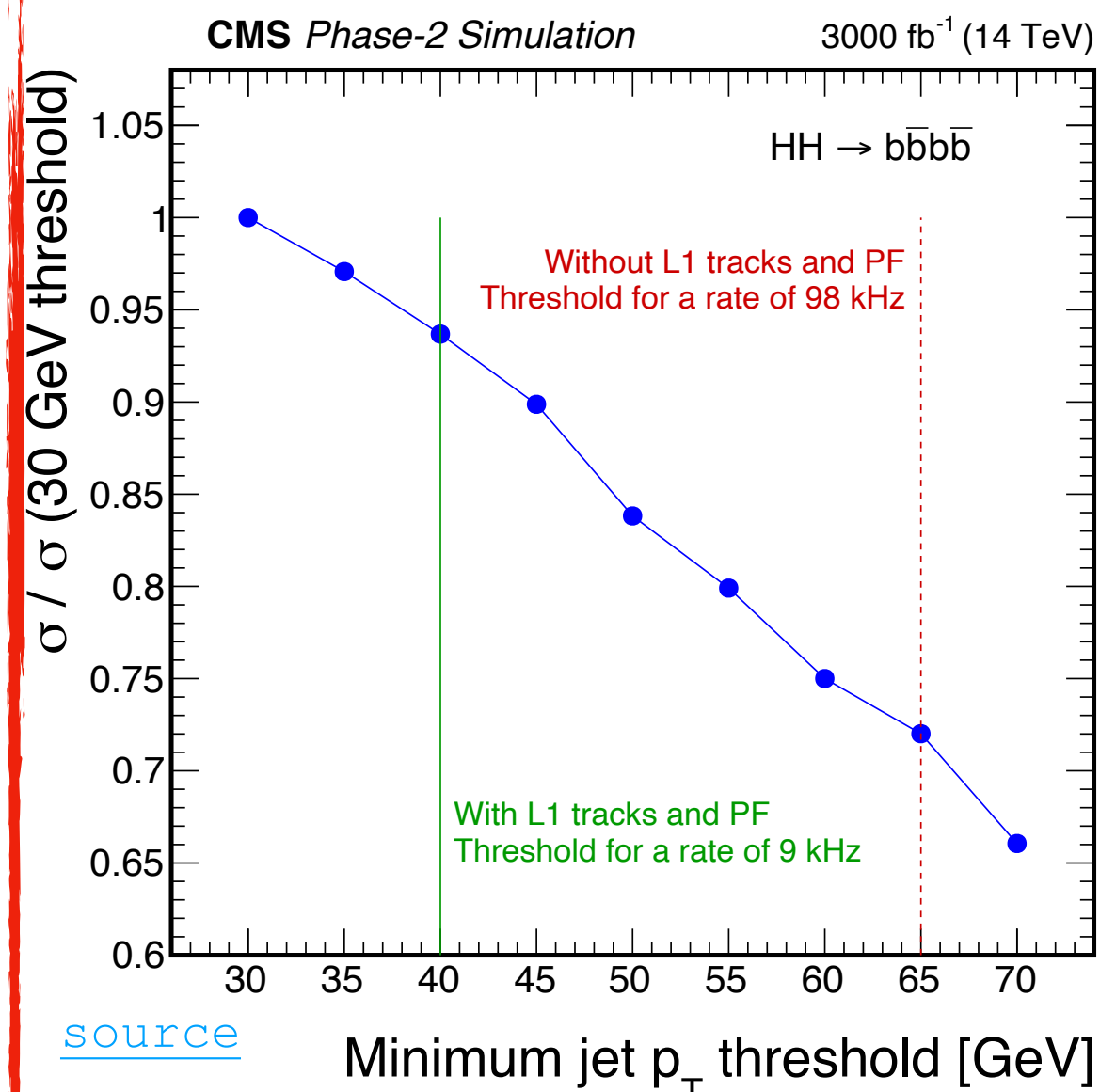

- **bbbb among most sensible final states** (thanks bbbb large branching ratio)
→ suffers from very large multi-jet background
- **Pseudorapidity coverage extension central for increasing acceptance**
- Upper limit @ 95% CL = **2.1 x SM**
- Significance of HH signal **0.95σ**

⇒ **x3.5 improvement compared to Run2**

HH → bbbb

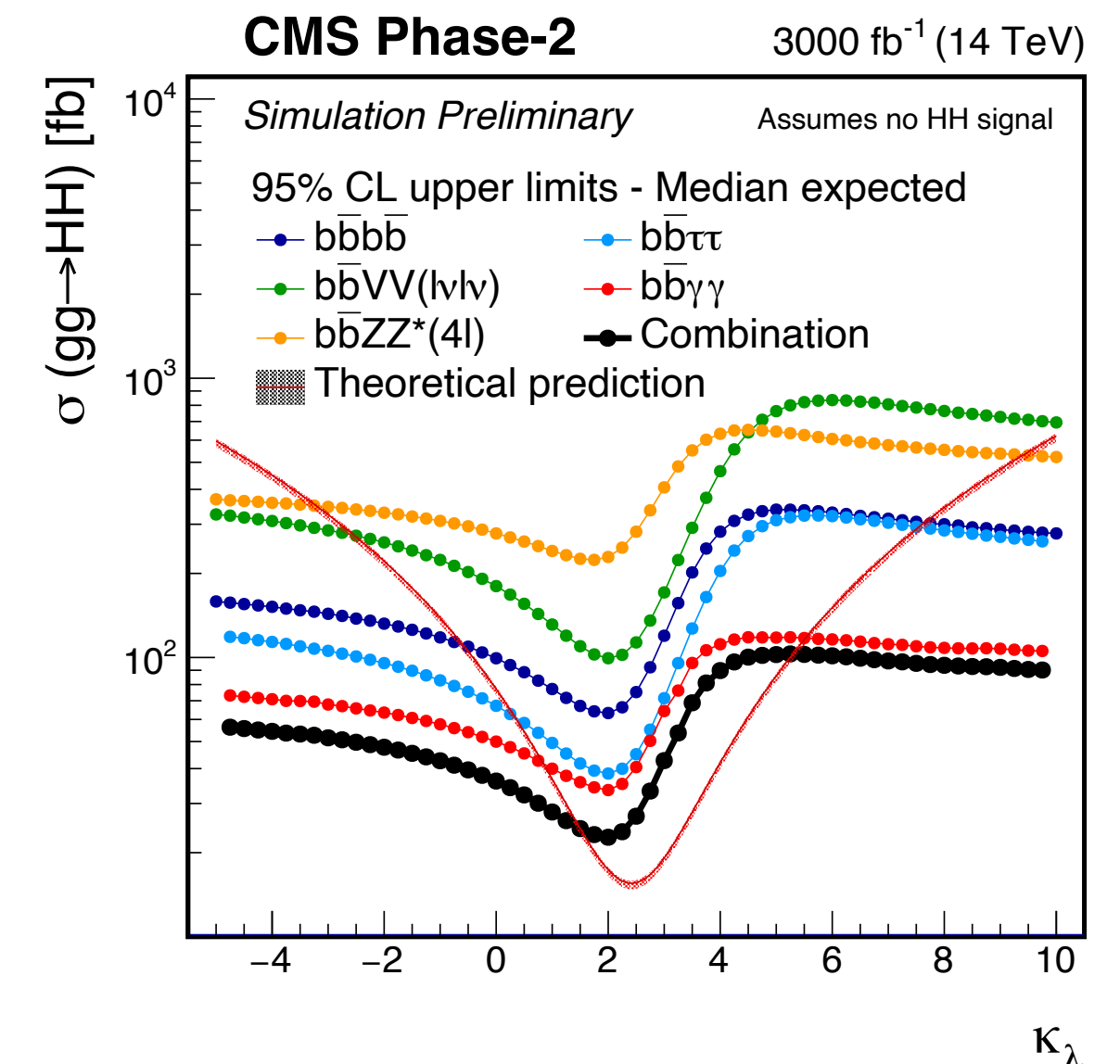

Extending the physics reach...

- ...with tracking at Level-1 trigger
- ...with extended η coverage
- ...with displaced objects
- ...with ML-based trigger algorithms

...with tracking at Level-1 trigger

First ever inclusion of track information at L1 Trigger

Using the **full outer tracker ($\eta < 2.4$) volume** and a **time-multiplexed architecture (x18)**, the Track Trigger gives the ability to reconstruct charged particle tracks at the 40 MHz collision rate.

In combination with the **Correlator Trigger** gives the possibility to precisely reconstruct **primary and secondary vertexes** per each collision.

Using the L1 Track trigger guarantees to obtain unprecedented trigger capabilities

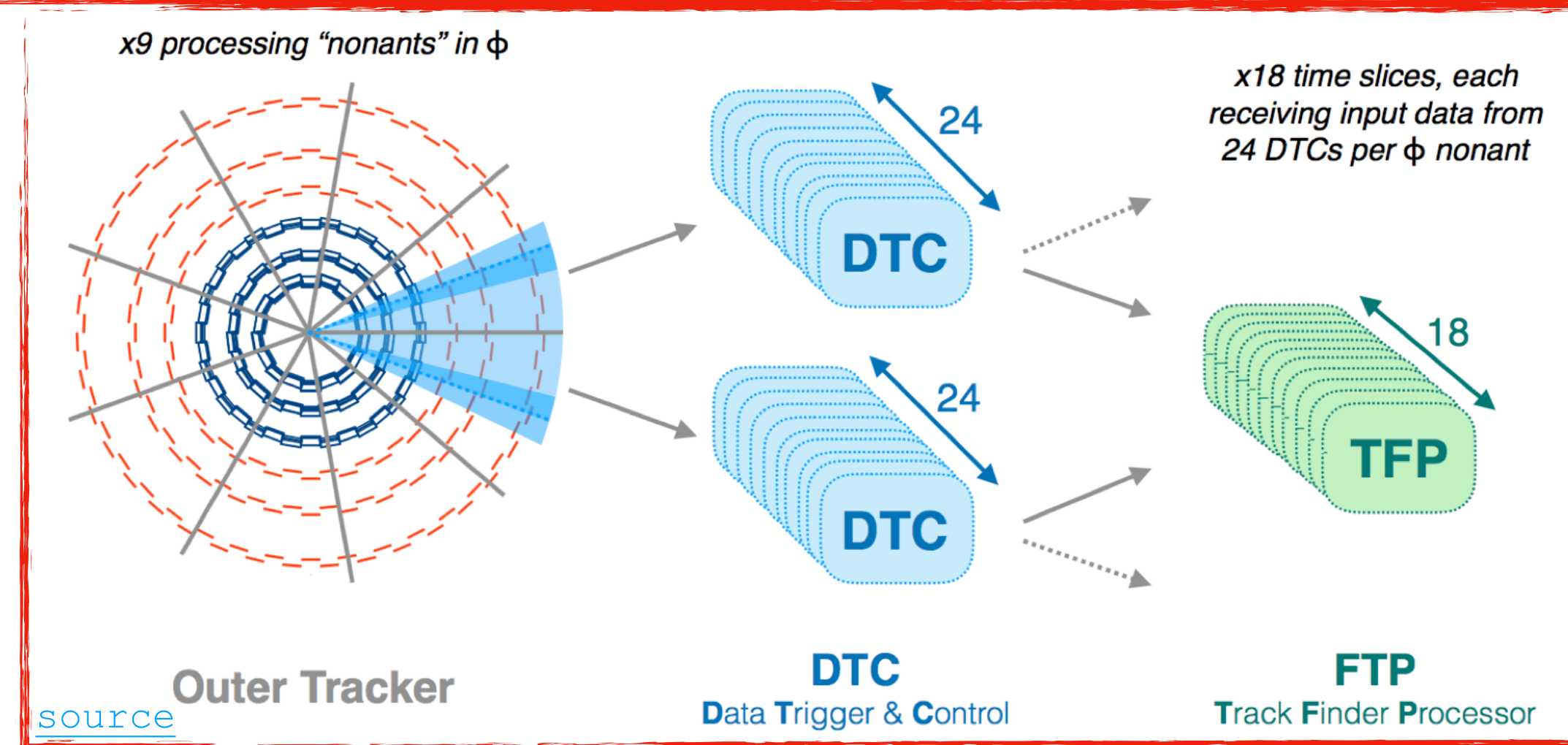

...with tracking at Level-1 trigger

First ever inclusion of track information at L1 Trigger

Using the **full outer tracker ($\eta < 2.4$) volume** and a **time-multiplexed architecture (x18)**, the Track Trigger gives the ability to reconstruct charged particle tracks at the 40 MHz collision rate. In combination with the **Correlator Trigger** gives the possibility to precisely reconstruct **primary and secondary vertexes** per each collision.

Using the L1 Track trigger guarantees to obtain unprecedented trigger capabilities

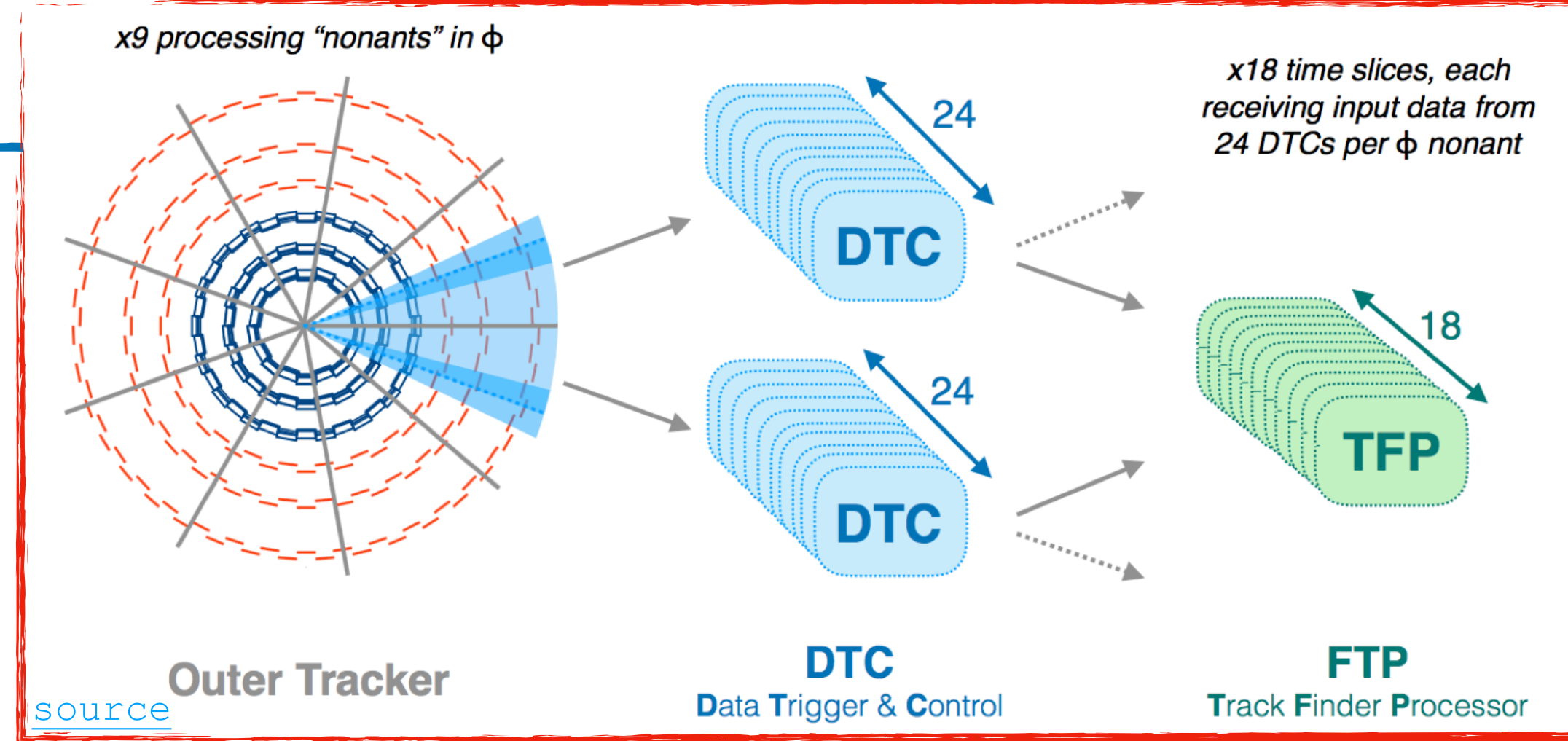

⇒ **x5 improvement compared to current world average**

B physics and CP violation

- $B_s^0 \rightarrow J/\psi\phi(1020)$ CP violation golden channel
- Amazing **ct** resolution reachable with Phase2 tracker
- Expected uncertainty on CP-violating phase $\phi_s \sim 5-6$ mrad

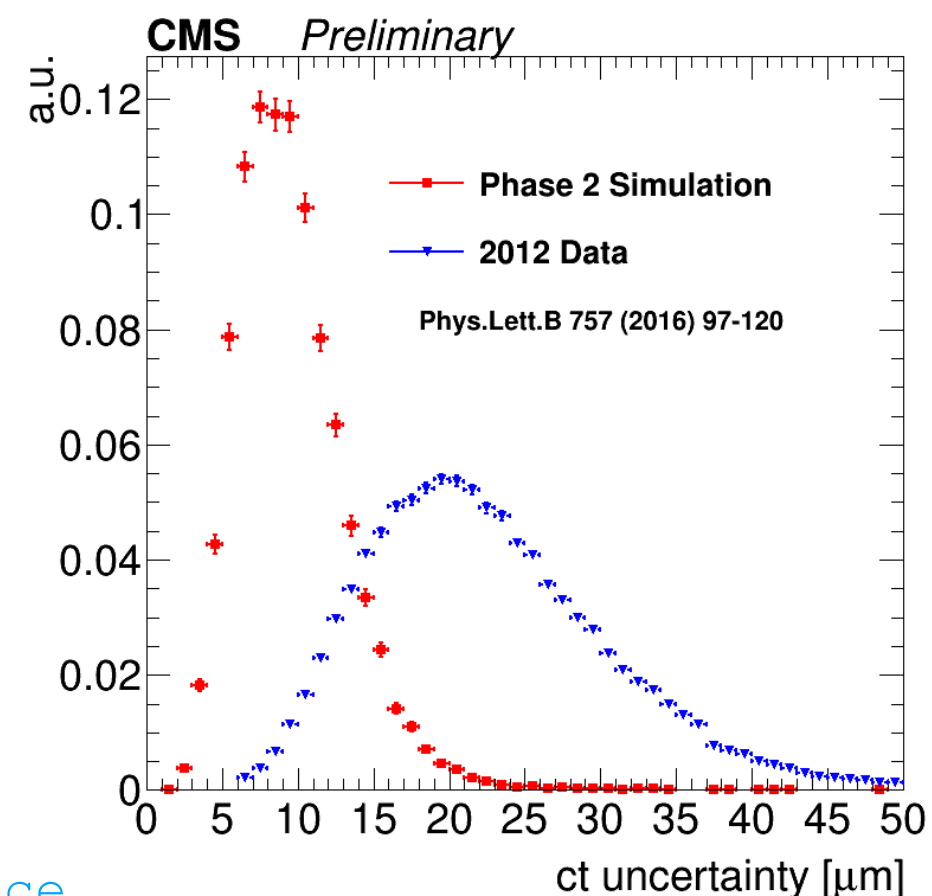

source

...with tracking at Level-1 trigger

First ever inclusion of track information at L1 Trigger

Using the **full outer tracker ($\eta < 2.4$) volume** and a **time-multiplexed architecture (x18)**, the Track Trigger gives the ability to reconstruct charged particle tracks at the 40 MHz collision rate. In combination with the **Correlator Trigger** gives the possibility to precisely reconstruct **primary and secondary vertexes** per each collision.

Using the L1 Track trigger guarantees to obtain unprecedented trigger capabilities

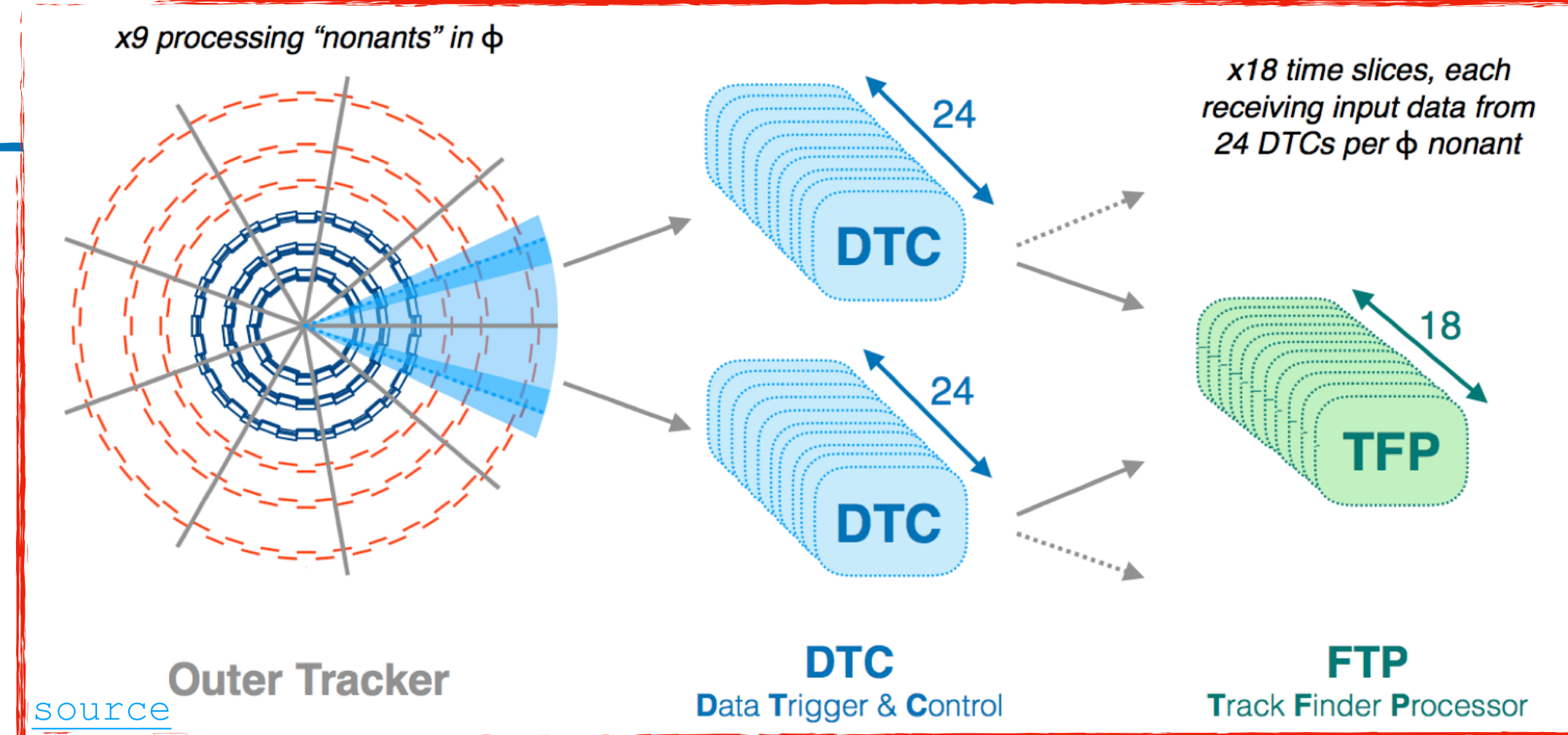

⇒ **x5 improvement compared to current world average**

• Main source from $D_s \rightarrow \tau \nu$

⇒ **very low momentum τ 's and μ 's (~1.3% have $p > 2.5$ GeV)**

⇒ **tracker necessary to retrieve at L1 the muons that do not reach the muon chambers**

$\tau \rightarrow \mu \mu \mu$ lepton flavour violation

- No known symmetries strictly forbid **lepton-flavor violating (LFV) decays**
- At the LHC, the $\tau \rightarrow \mu \mu \mu$ decay is one of the "**cleanest**" **LFV decay channel**
- $\approx 10^{15}$ τ leptons will be **produced at HL-LHC**

B physics and CP violation

- $B_s^0 \rightarrow J/\psi \phi(1020)$ **CP violation golden channel**
- Amazing **ct resolution reachable with Phase2 tracker**
- Expected uncertainty on CP-violating phase $\phi_s \sim 5-6$ mrad

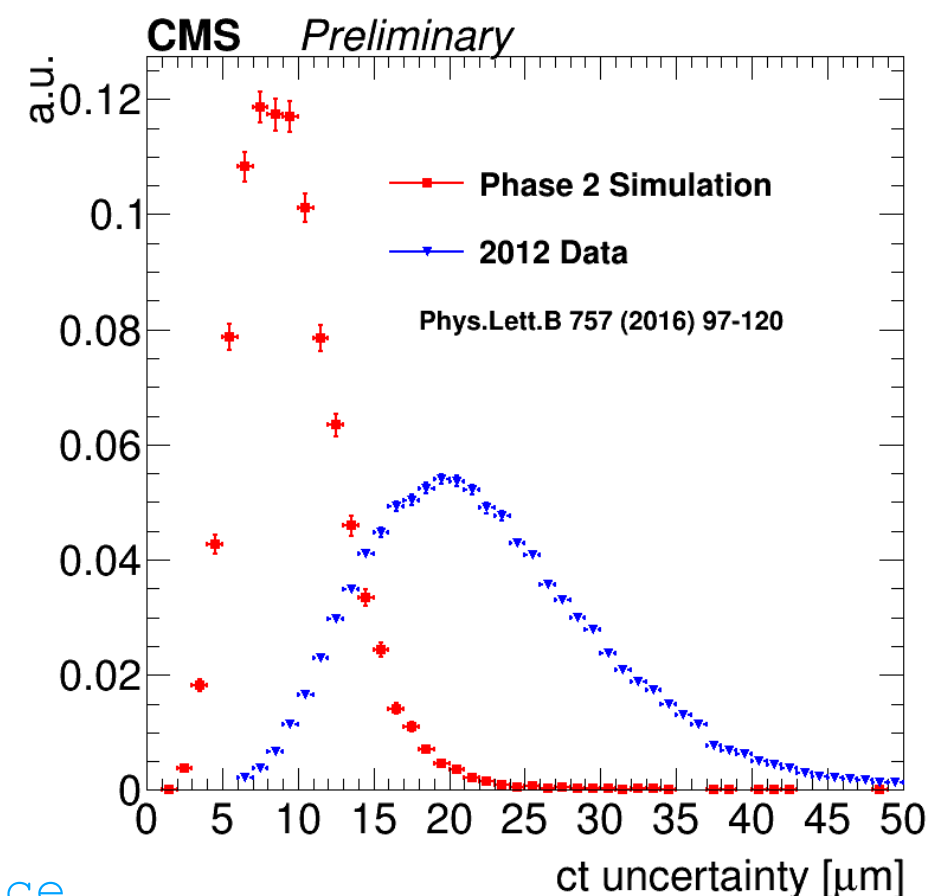

source

...with extended η coverage

Extended pseudorapidity acceptance

The L1 pseudorapidity coverage is increased thanks to:

- * the upgraded **endcap μ detectors** ($|\eta| < 2.8$)
- * the upgraded **endcap calorimeters** ($|\eta| < 3$)

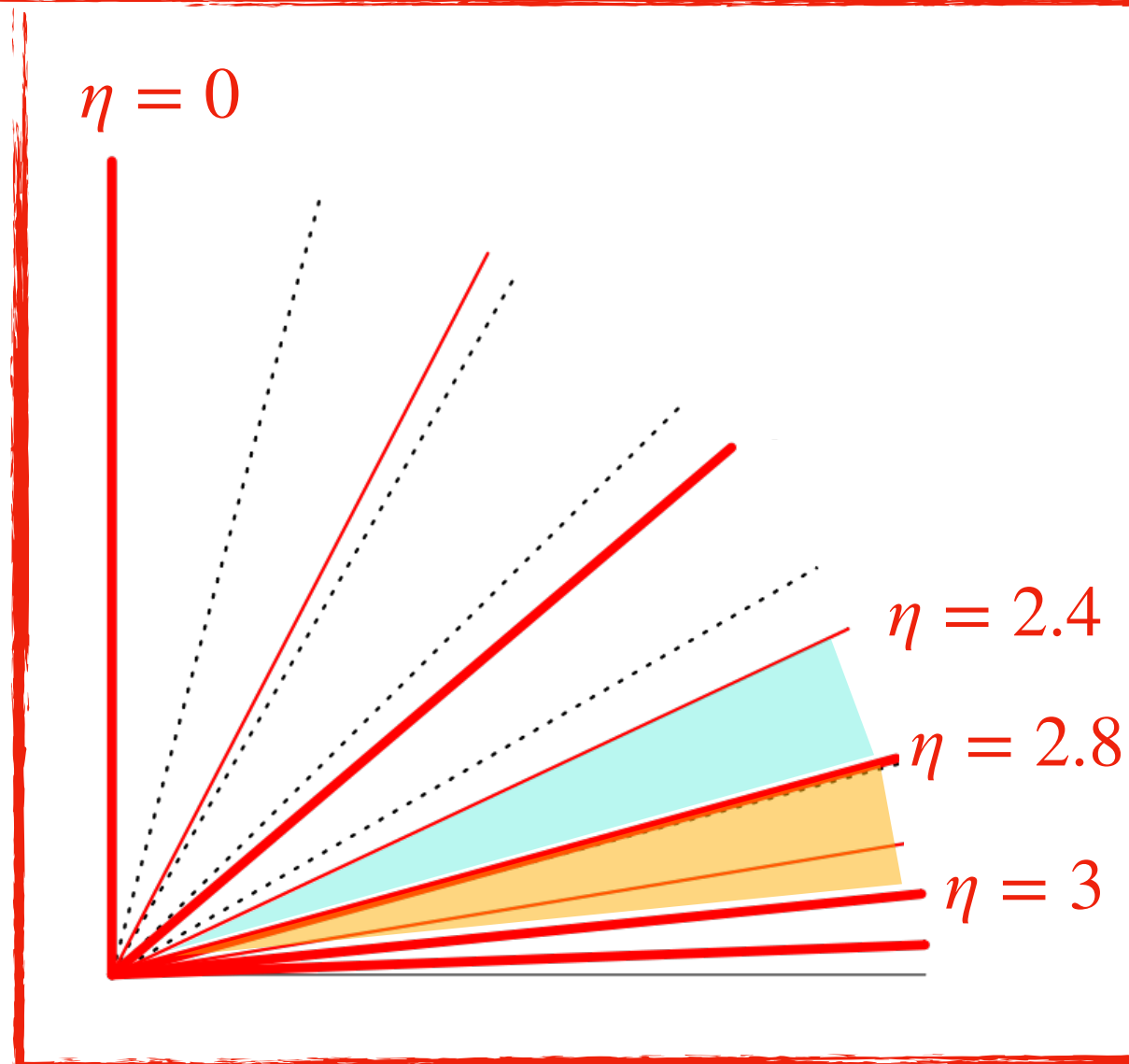

...with extended η coverage

Extended pseudorapidity acceptance

The L1 pseudorapidity coverage is increased thanks to:

- * the upgraded **endcap μ detectors** ($|\eta| < 2.8$)
- * the upgraded **endcap calorimeters** ($|\eta| < 3$)

Weak mixing angle measurement

- Part of the **precision measurements program of the HL-LHC**
- Done using the using **forward-backward asymmetry**
- Primary channel is **Drell-Yan decaying to $\mu\mu$**
- **η extension decreases statistical uncertainties by $\sim 30\%$ and PDF by $\sim 20\%$**

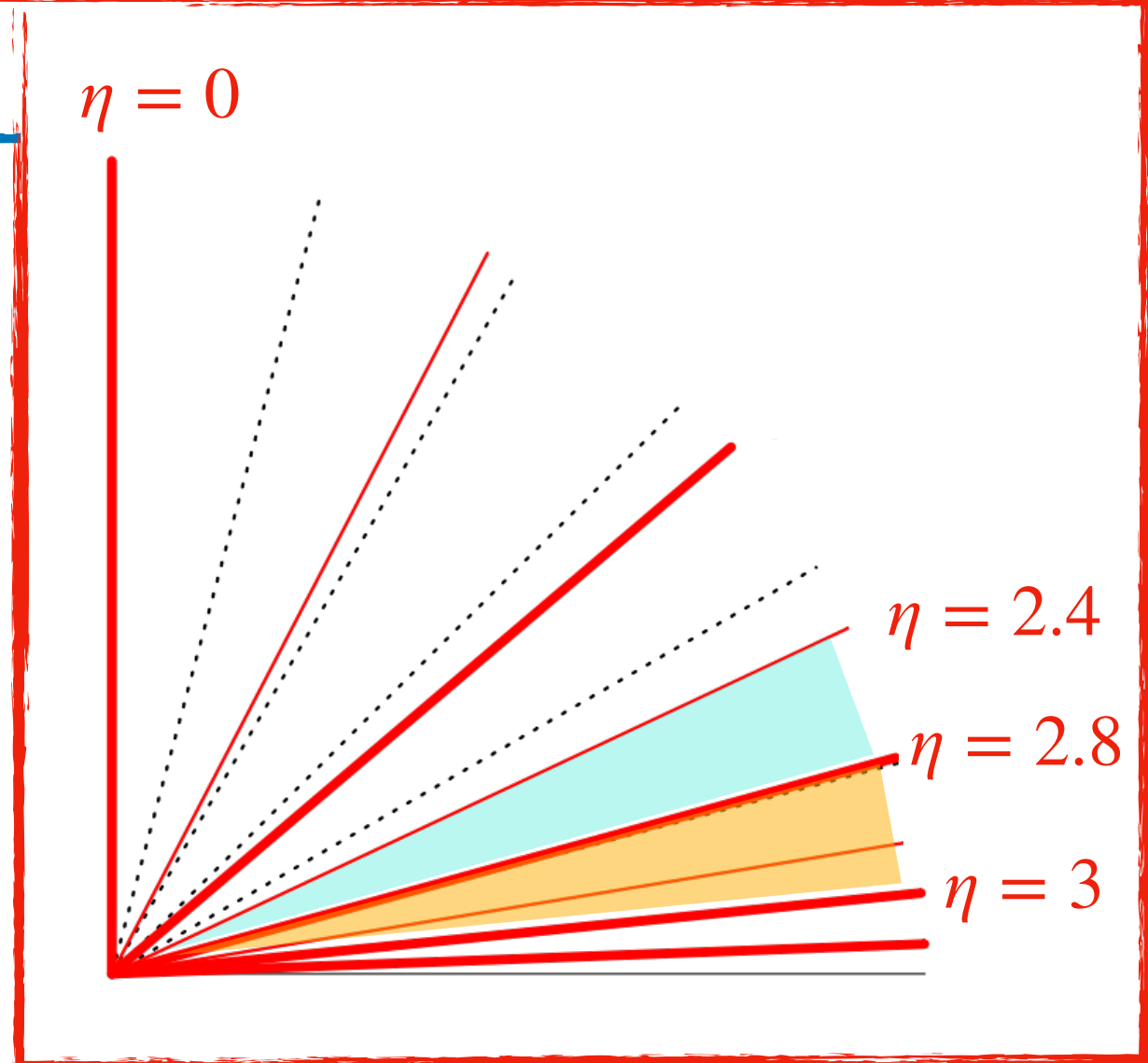
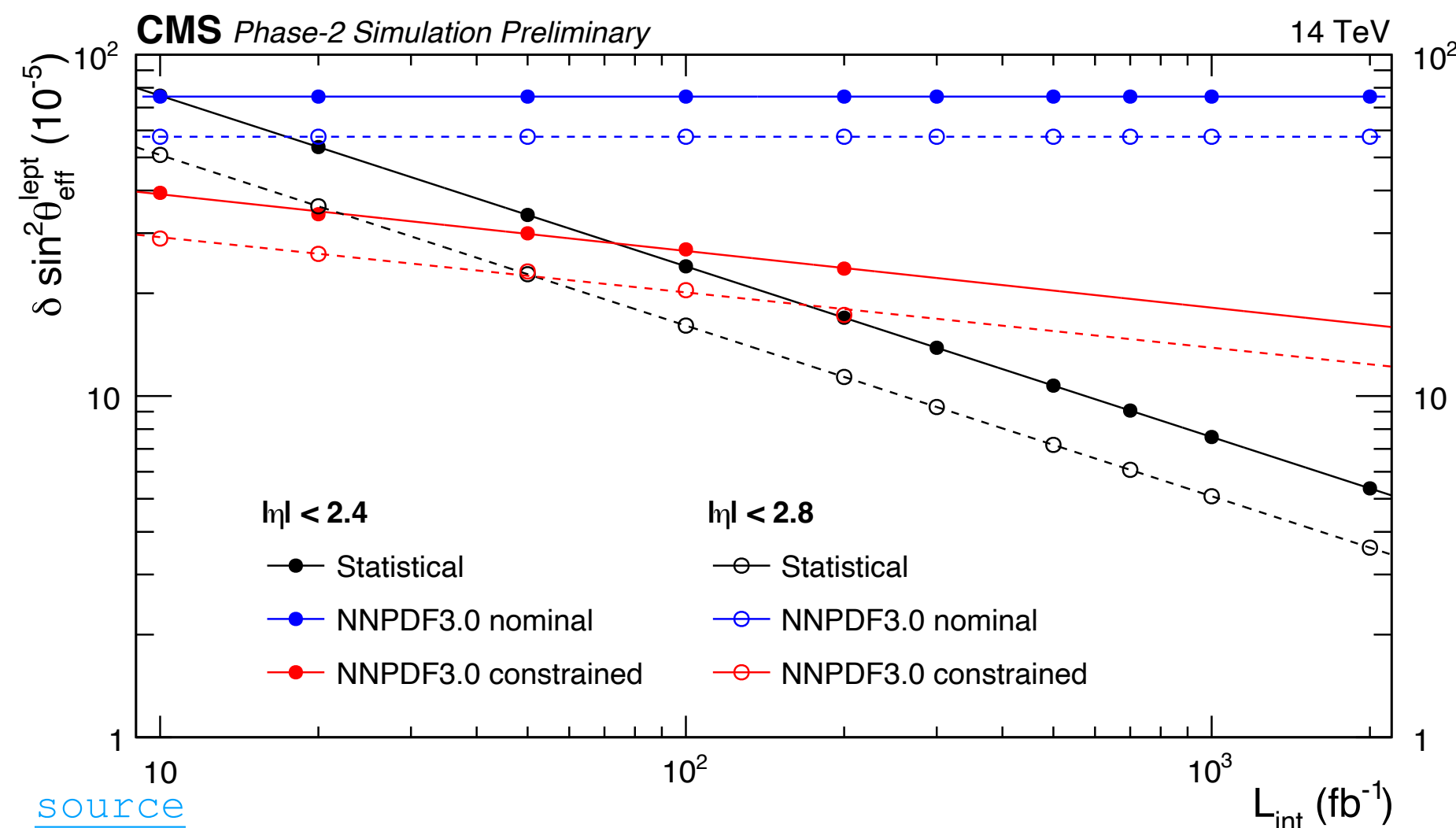

...with extended η coverage

Extended pseudorapidity acceptance

The L1 pseudorapidity coverage is increased thanks to:

- * the upgraded **endcap μ detectors** ($|\eta| < 2.8$)
- * the upgraded **endcap calorimeters** ($|\eta| < 3$)

Weak mixing angle measurement

- Part of the **precision measurements program of the HL-LHC**
- Done using the using **forward-backward asymmetry**
- Primary channel is **Drell-Yan decaying to $\mu\mu$**
- **η extension decreases statistical uncertainties by $\sim 30\%$ and PDF by $\sim 20\%$**

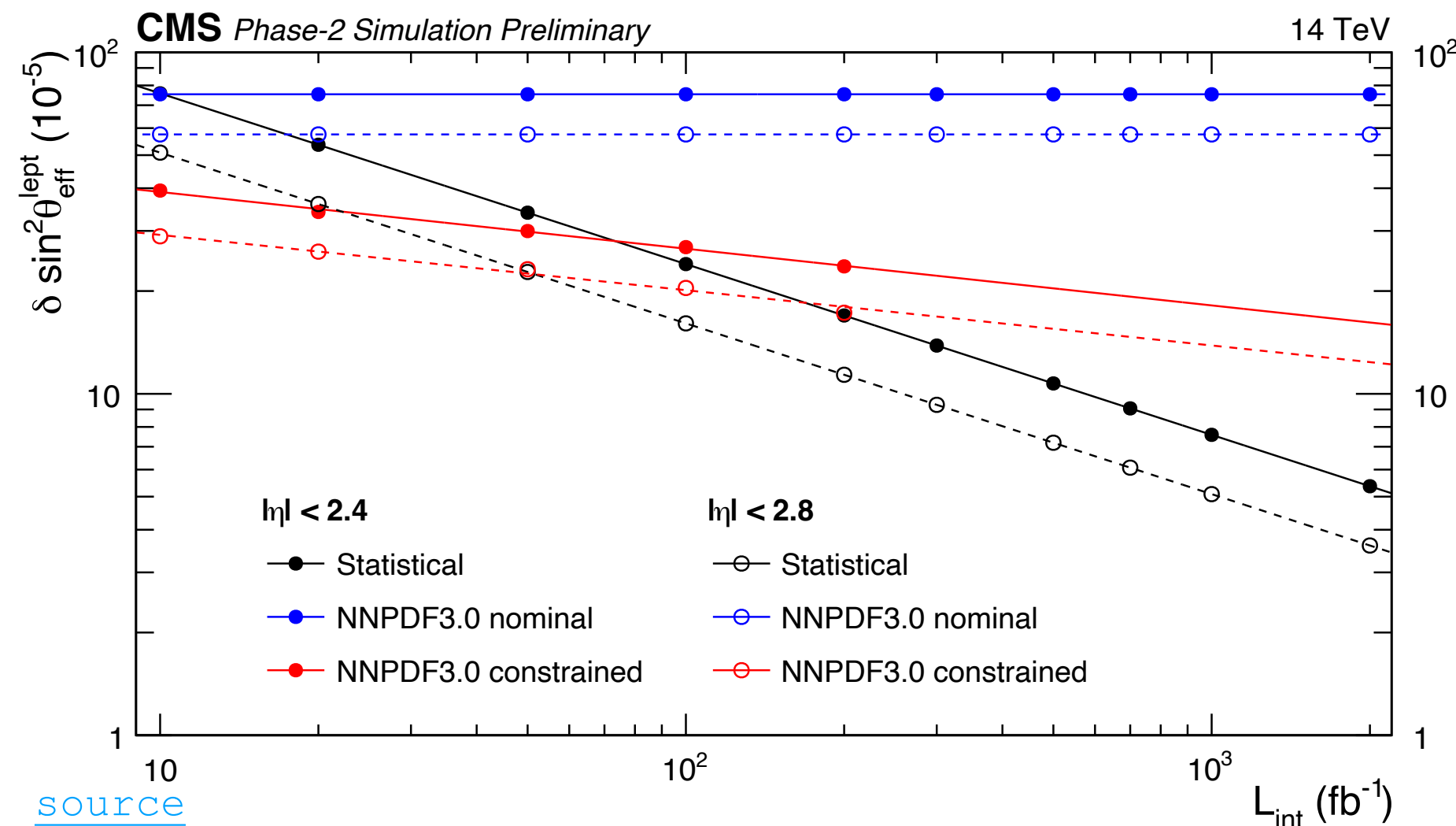

[source](#)

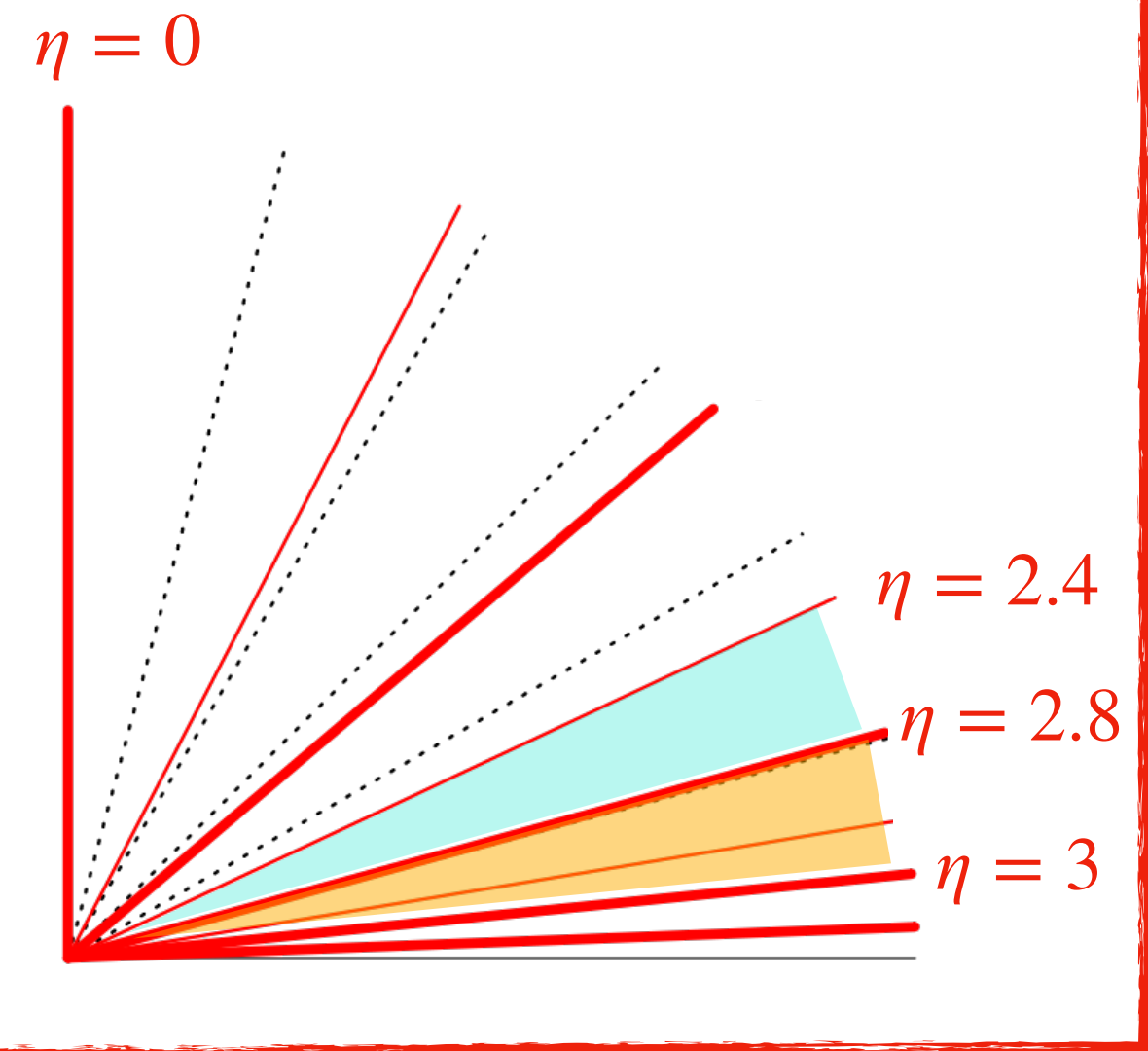

$\tau \rightarrow \mu\mu\mu$ lepton flavour violation

- Main source from **$D_s \rightarrow \tau \nu$**
- \Rightarrow **highly forward boosted τ**
- \Rightarrow **extended η coverage will allow to drastically increase statistics**

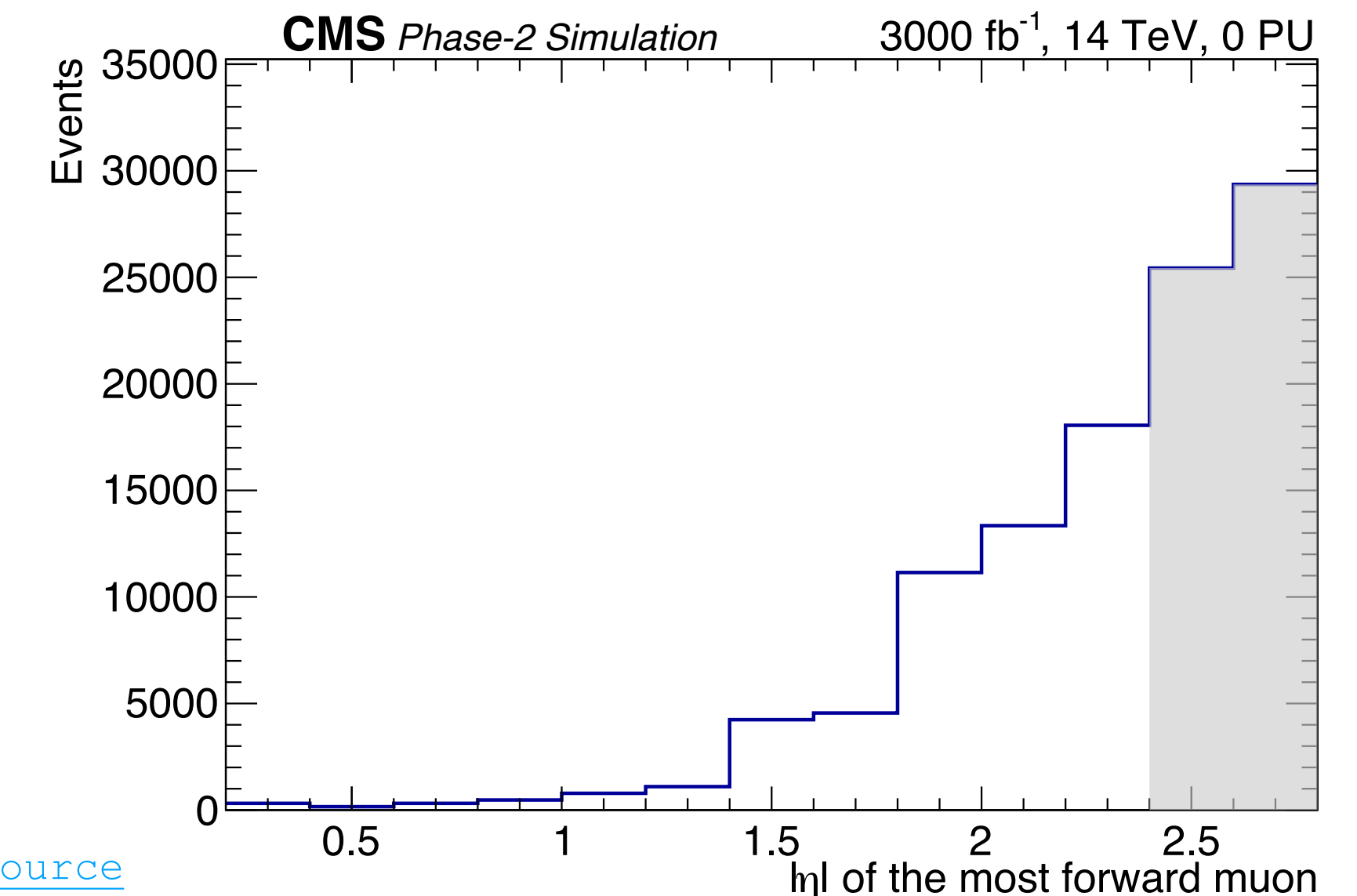

[source](#)

...with displaced objects

Extending displaced object capabilities w/ track information

Displaced objects reconstructed through:

- * **Track Trigger** reconstructing tracks while removing interaction point constraint
- * **Correlator Trigger** reconstructing secondary vertexes
- * **Timig information** from the barrel

This Guarantees unprecedented capabilities in term of displace objects algorithms implementation

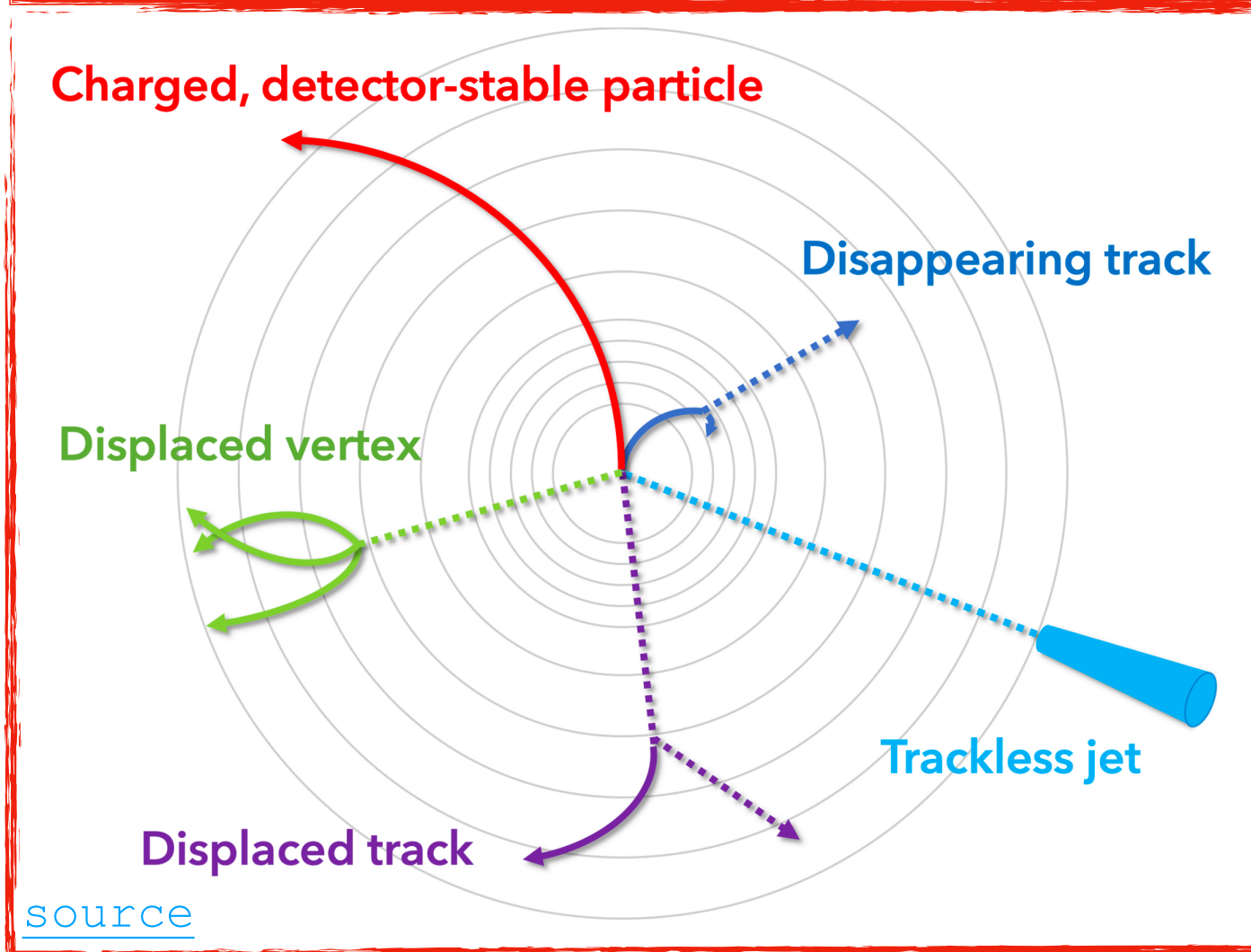

...with displaced objects

Extending displaced object capabilities w/ track information

Displaced objects reconstructed through:

- * **Track Trigger** reconstructing tracks while removing interaction point constraint
- * **Correlator Trigger** reconstructing secondary vertexes
- * **Timig information** from the barrel

This Guarantees unprecedented capabilities in term of displace objects algorithms implementation

Long-lived particles searches

Charged, detector-stable particle

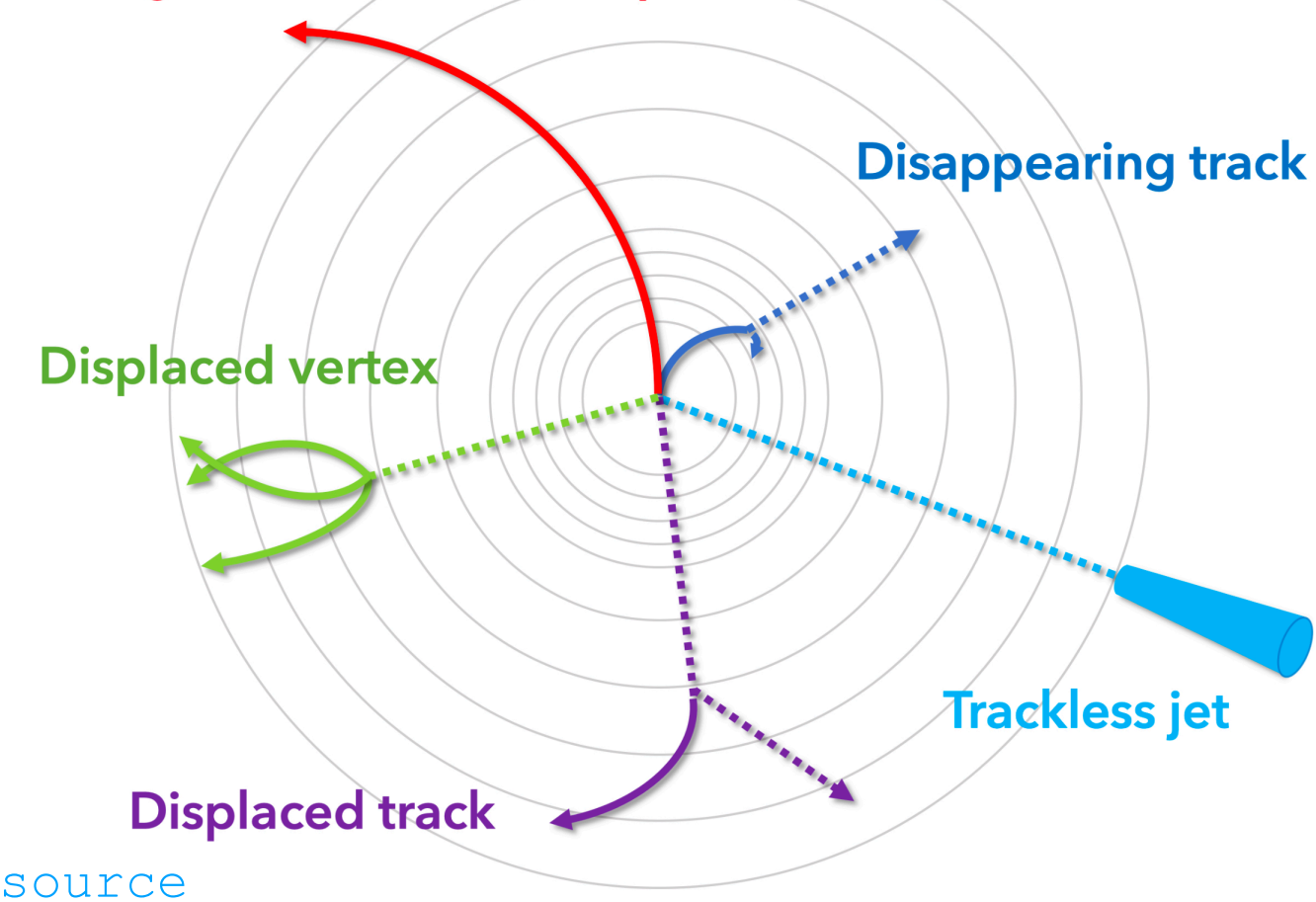

- Growing class of new physics models predicts **long-lived particles (LLPs)**
- Signature with emergence of **SM particles at a large distance from the collision point**

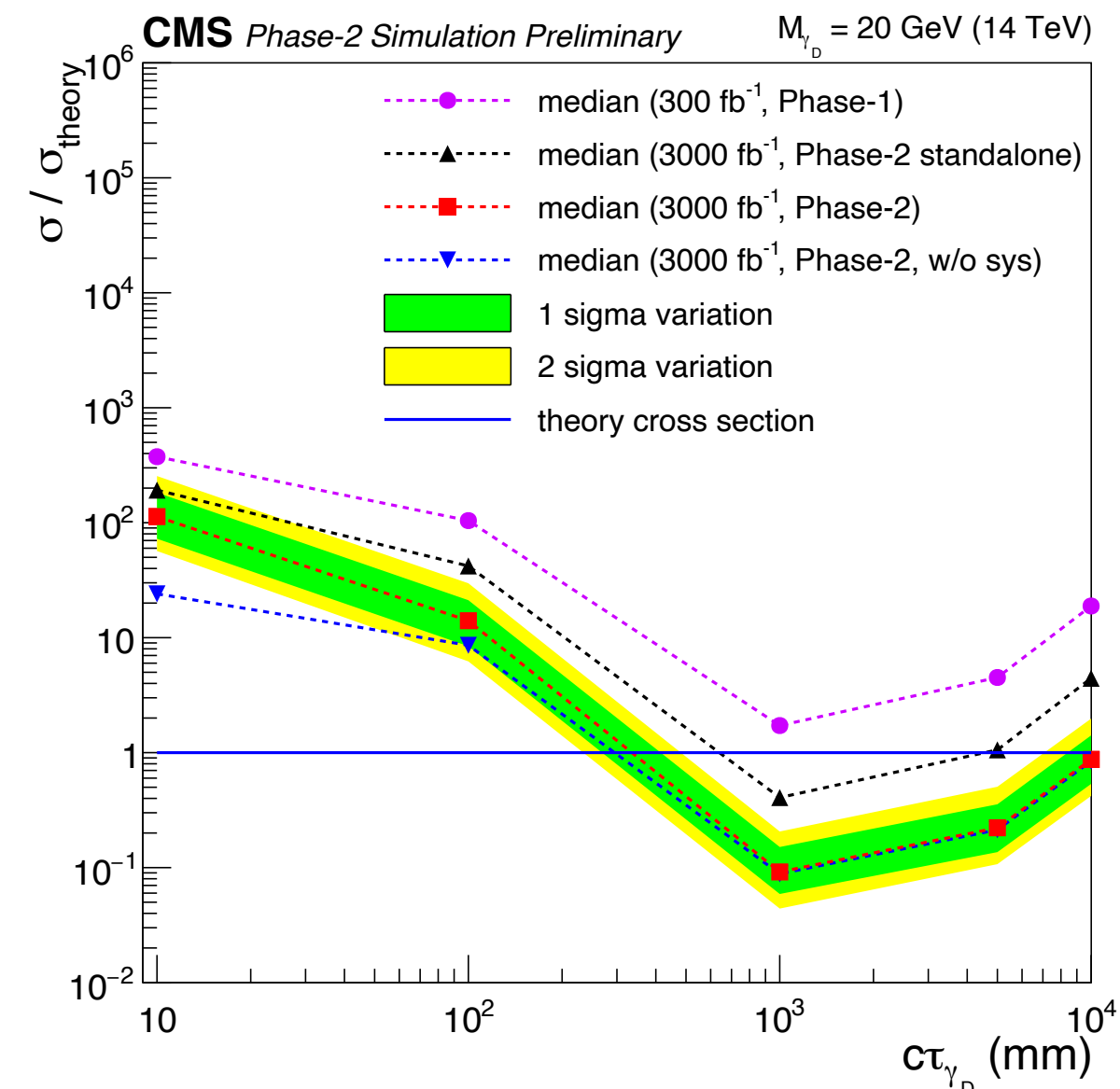
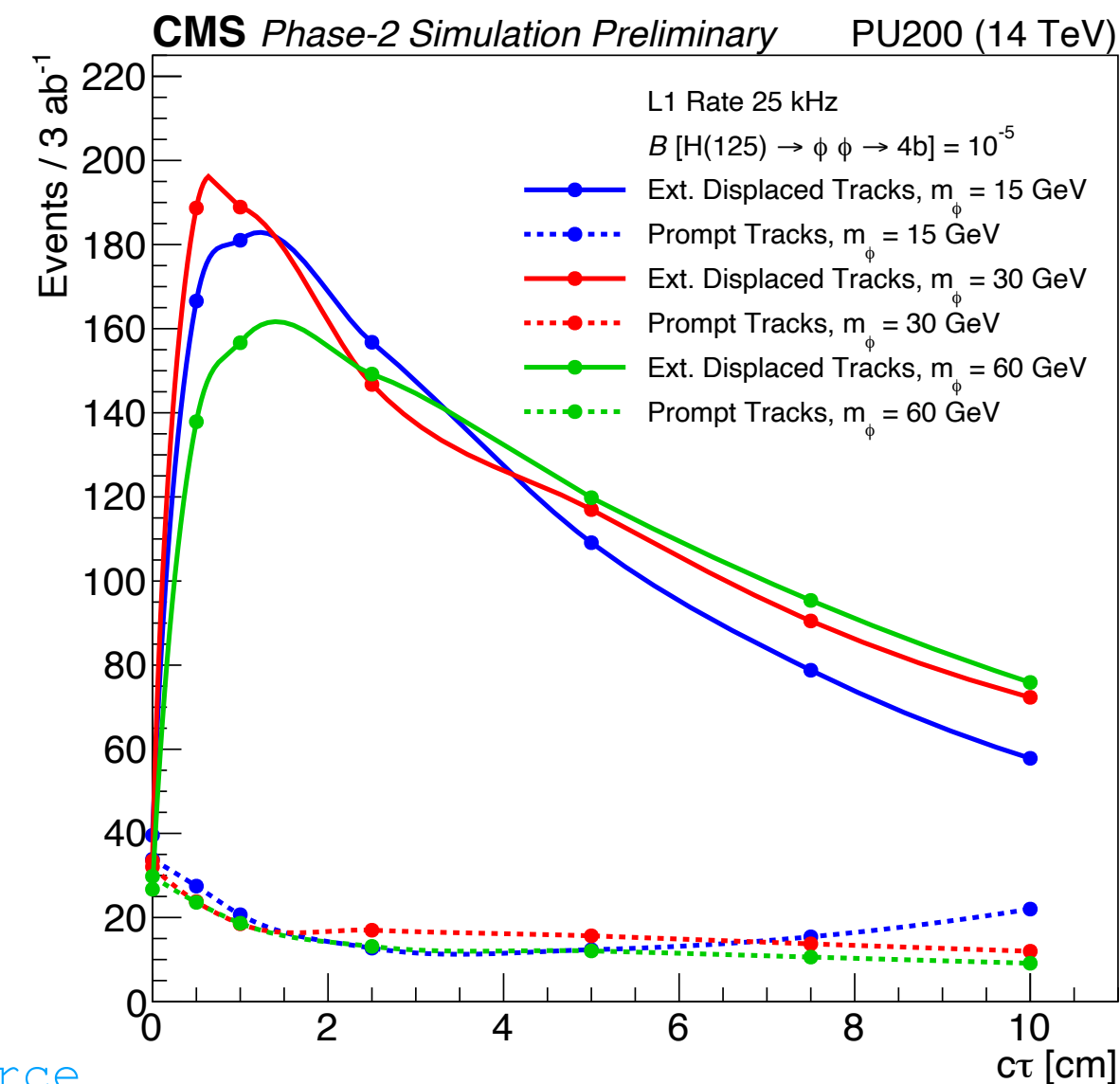

⇒ **unprecedented acceptance of displaced topology objects**

...with ML-based trigger algorithms

Using advanced Machine Learning technique at L1 Trigger

The many hardware improvements of the Phase-2 L1 Trigger architecture give the possibility to **implement ML techniques (DNNs, BDTs, etc)** to perform fast but precise real-time event reconstruction

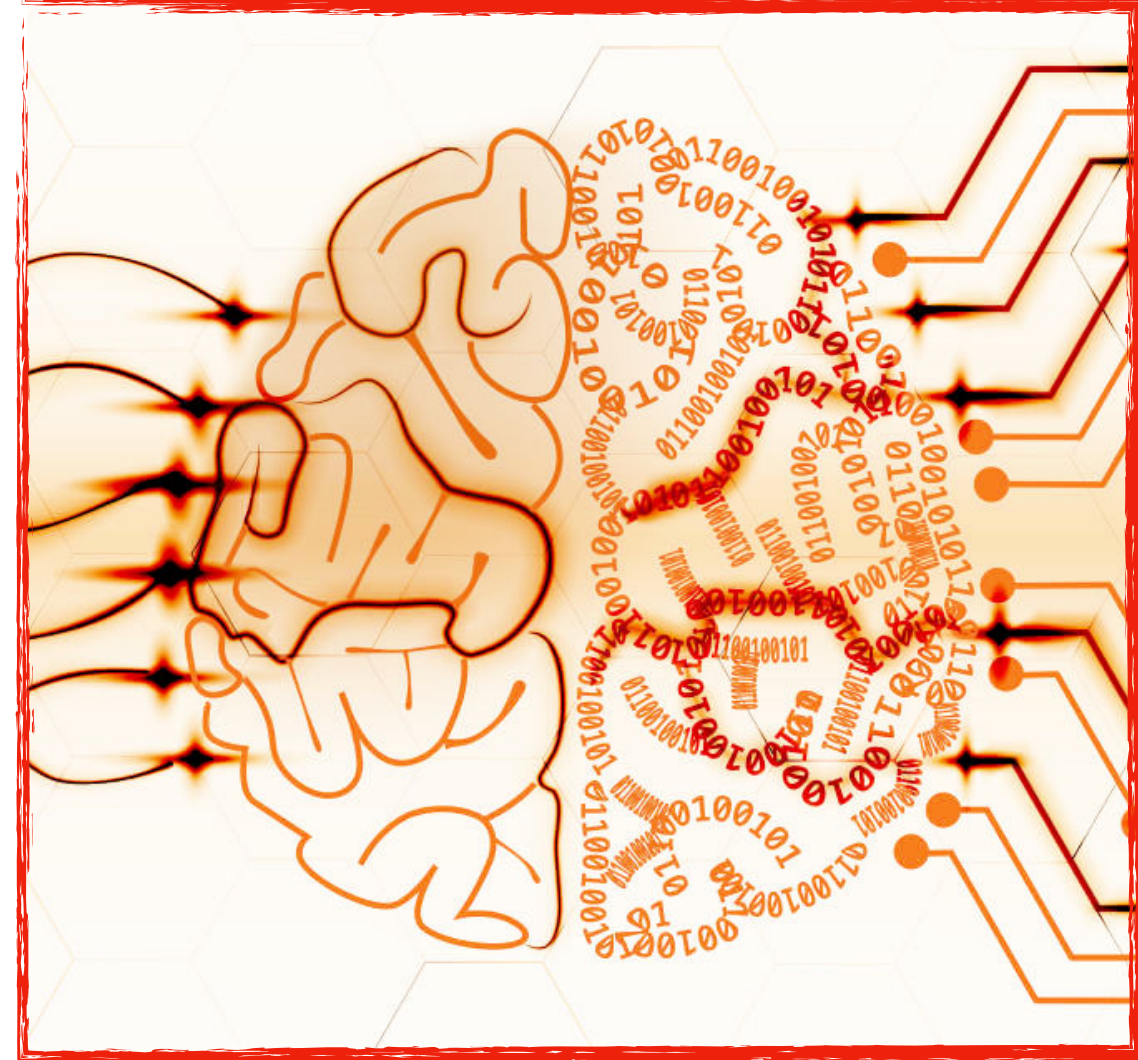

...with ML-based trigger algorithms

Using advanced Machine Learning technique at L1 Trigger

The many hardware improvements of the Phase-2 L1 Trigger architecture give the possibility to **implement ML techniques (DNNs, BDTs, etc)** to perform fast but precise real-time event reconstruction

PUPPI algorithm (as a representative of many algorithms)

- The Pileup Per Particle Identification (**PUPPI**) is based on a **Neural Network using the particle-flow approach** (it originated from an offline tool redesigned to fit trigger requirements)
- The Phase 2 upgrade ensures the possibility of **implementing such an algorithm inside the L1 trigger FPGAs boards**
- PUPPI relies on the use of **vertexing to reduce the contribution of pileup at the particle level**

⇒ **unprecedented possibilities coming from ML implementability at L1 trigger level**

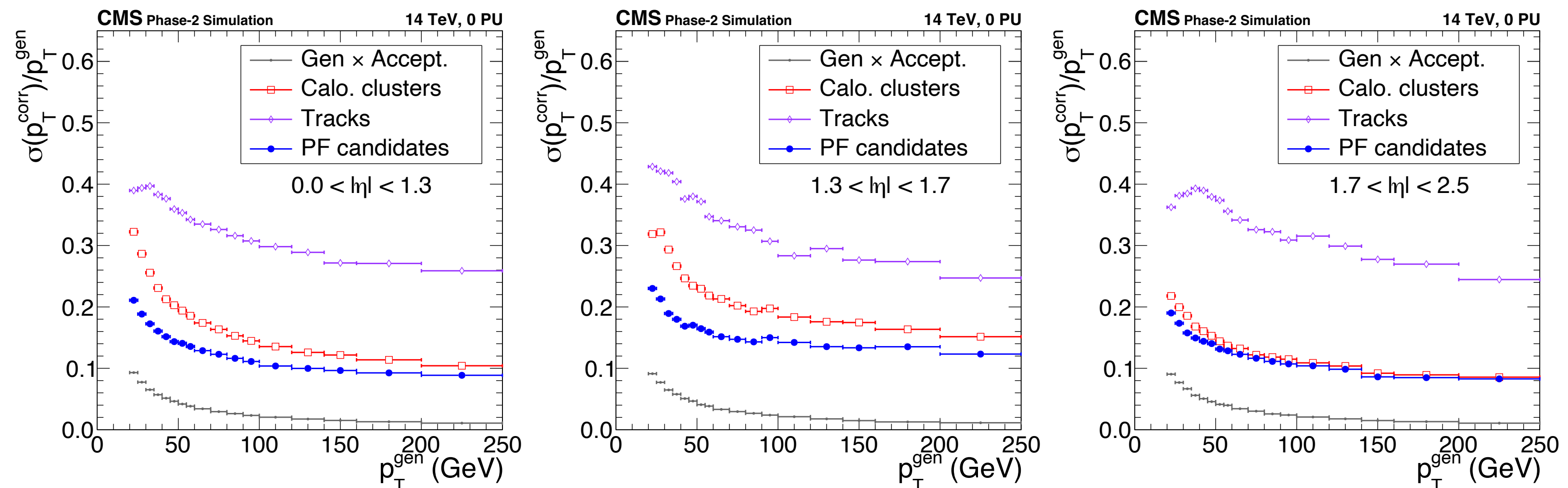

[source](#)

...with ML-based trigger algorithms

Using advanced Machine Learning technique at L1 Trigger

The many hardware improvements of the Phase-2 L1 Trigger architecture give the possibility to **implement ML techniques (DNNs, BDTs, etc)** to perform fast but precise real-time event reconstruction

PUPPI algorithm (as a representative of many algorithms)

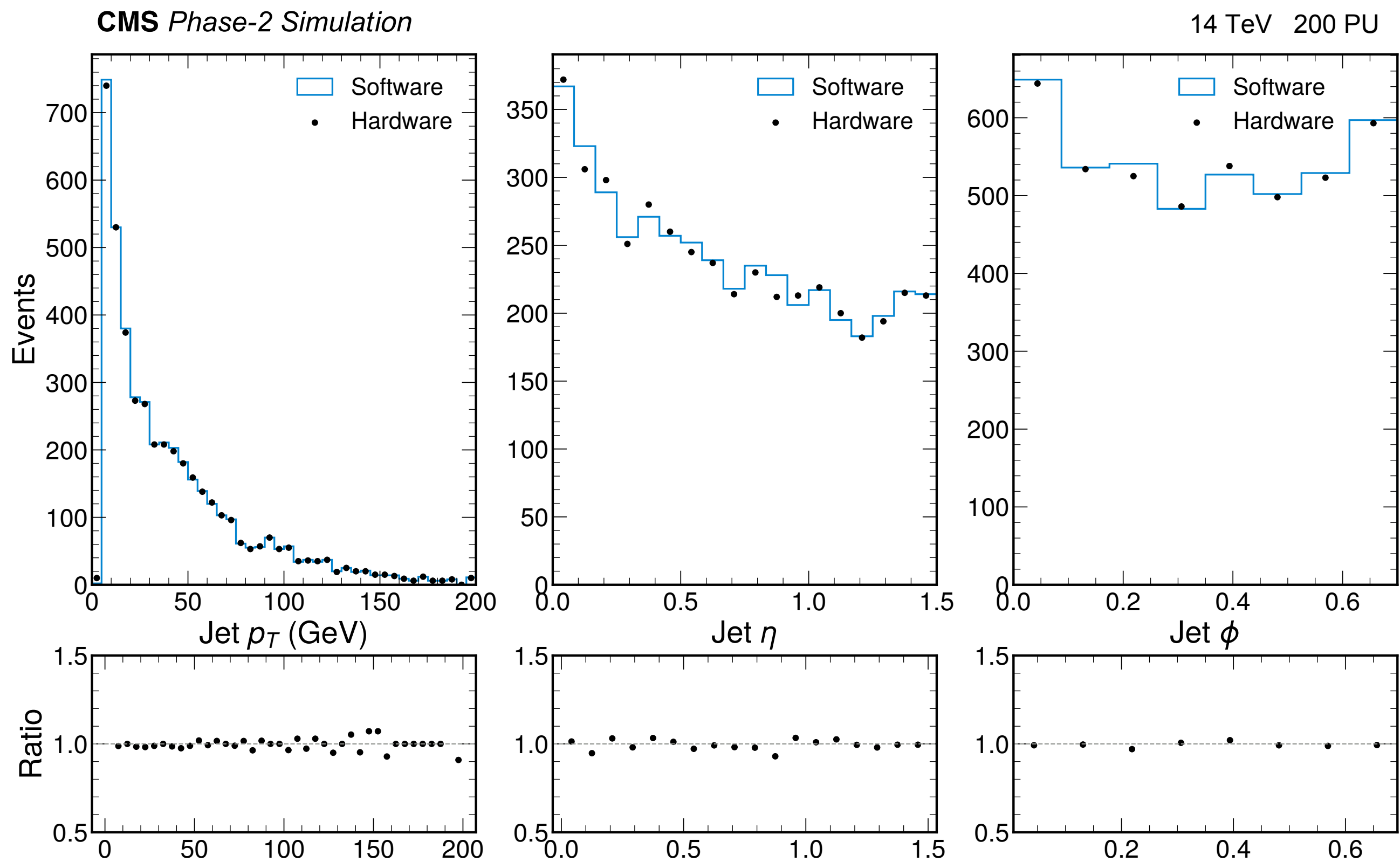
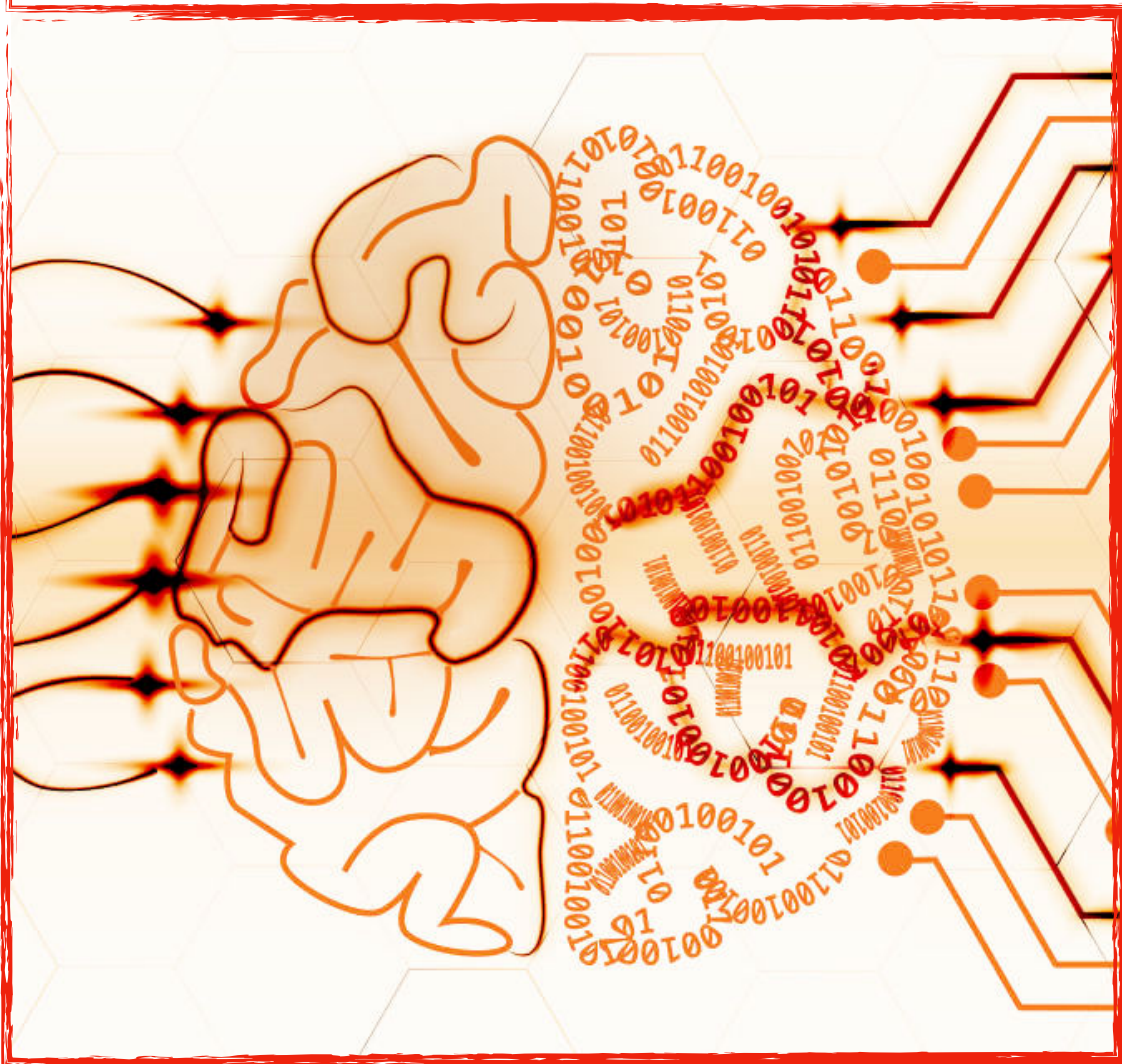

[source](#)

⇒ almost perfect (98%) match between hardware demonstration and software emulation



Conclusions and outlook

Conclusions and outlook

- **HL-LHC** will pose **big challenges** for CMS experiment \Rightarrow **experiment wide upgrade**, both hardware and software
- Today we focused on the **Phase-2 Level-1 Trigger upgrade** and we saw:
 - * **L1 trigger main hardware features...**
 - ...high speed links
 - ...state-of-the-art FPGAs
 - * **Preserve the discovery potential...**
 - ...with single-lepton trigger algorithms
 - ...with double- γ trigger algorithms
 - ...with double- τ trigger algorithms
 - ...with multi-jet trigger algorithms
 - * **L1 trigger architecture main upgrades...**
 - ...inclusion of the Track Trigger
 - ...the new Correlator Trigger
 - * **Extend the physics reach...**
 - ...with tracking at Level-1 trigger
 - ...with extended η coverage
 - ...with displaced objects
 - ...with ML-based trigger algorithms
- **All analyses that can be envisaged will benefit from the Phase-2 L1 trigger**
- The prospects for the full Phase-2 dataset analyses foresee **very large improvements** in their results
- During the coming years the **L1 Trigger Team** will keep on pushing the boundaries of triggering at CMS and will **continue** in the **hardware demonstration of the trigger algorithms** (many demonstrations already done!)...

...till our *adventures* will lead us ***Through the Looking-Glass***



Thanks for your kind attention!

BACKUP

source of everything hereafter

BACKUP:

L1 Trigger menu

L1 Trigger seeds	Offline Threshold(s) at 90% or 95% (50%) [GeV]	Rate $\langle PU \rangle = 200$ [kHz]	Additional Requirement(s) [cm, GeV]	Objects plateau efficiency [%]
Single/Double/Triple Lepton (electron, muon) seeds				
Single TkMuon	22	12	$ \eta < 2.4$	95
Double TkMuon	15,7	1	$ \eta < 2.4, \Delta z < 1$	95
Triple TkMuon	5,3,3	16	$ \eta < 2.4, \Delta z < 1$	95
Single Tkelectron	36	24	$ \eta < 2.4$	93
Single TkiElectron	28	28	$ \eta < 2.4$	93
TkiElectron-StaEG	22, 12	36	$ \eta < 2.4$	93, 99
Double Tkelectron	25, 12	4	$ \eta < 2.4$	93
Single StaEG	51	25	$ \eta < 2.4$	99
Double StaEG	37,24	5	$ \eta < 2.4$	99
Photon seeds				
Single TkiPhoton	36	43	$ \eta < 2.4$	97
Double TkiPhoton	22, 12	50	$ \eta < 2.4$	97
Taus seeds				
Single CaloTau	150(119)	21	$ \eta < 2.1$	99
Double CaloTau	90,90(69,69)	25	$ \eta < 2.1, \Delta R > 0.5$	99
Double PuppiTau	52,52(36,36)	7	$ \eta < 2.1, \Delta R > 0.5$	90
Hadronic seeds (jets, H_T)				
Single PuppiJet	180	70	$ \eta < 2.4$	100
Double PuppiJet	112,112	71	$ \eta < 2.4, \Delta \eta < 1.6$	100
Puppi H_T	450(377)	11	jets: $ \eta < 2.4, p_T > 30$	100
QuadPuppiJets-Puppi H_T	70,55,40,40,40(328)	9	jets: $ \eta < 2.4, p_T > 30$	100,100
E_T^{miss} seeds				
Puppi E_T^{miss}	200(128)	18		100
Cross Lepton seeds				
TkMuon-TkiElectron	7,20	1	$ \eta < 2.4, \Delta z < 1$	95, 93
TkMuon-Tkelectron	7,23	3	$ \eta < 2.4, \Delta z < 1$	95, 93
Tkelectron-TkMuon	10,20	1	$ \eta < 2.4, \Delta z < 1$	93, 95
TkMuon-DoubleTkelectron	6,17,17	0.1	$ \eta < 2.4, \Delta z < 1$	95, 93
DoubleTkMuon-Tkelectron	5,5,9	4	$ \eta < 2.4, \Delta z < 1$	95, 93
PuppiTau-TkMuon	36(27),18	2	$ \eta < 2.1, \Delta z < 1$	90, 95
TkiElectron-PuppiTau	22,39(29)	13	$ \eta < 2.1, \Delta z < 1$ $\Delta R > 0.3$	93, 90

L1 Trigger seeds	Offline Threshold(s) at 90% or 95% (50%) [GeV]	Rate $\langle PU \rangle = 200$ [kHz]	Additional Requirement(s) [cm, GeV]	Objects plateau efficiency [%]
Cross Hadronic-Lepton seeds				
TkMuon-Puppi H_T	6,320(250)	4	$ \eta < 2.4, \Delta z < 1$	95,100
TkMuon-DoublePuppiJet	12,40,40	10	$ \eta < 2.4, \Delta R_{j\mu} < 0.4,$ $\Delta \eta_{jj} < 1.6, \Delta z < 1$	95,100
TkMuon-PuppiJet-Puppi E_T^{miss}	3,100,120(55)	14	$ \eta < 1.5, \eta < 2.4,$ $\Delta z < 1$	95,100, 100
DoubleTkMuon-PuppiJet-Puppi E_T^{miss}	3,3,60,130(64)	4	$ \eta < 2.4, \Delta z < 1$	95,100, 100
DoubleTkMuon-Puppi H_T	3,3,300(231)	2	$ \eta < 2.4, \Delta z < 1$	95,100
DoubleTkelectron-Puppi H_T	10,10,400(328)	0.9	$ \eta < 2.4, \Delta z < 1$	93,100
TkiElectron-Puppi H_T	26,190(124)	9	$ \eta < 2.4, \Delta z < 1$	93,100
Tkelectron-PuppiJet	28,40	34	$ \eta < 2.1, \eta < 2.4,$ $\Delta R > 0.3, \Delta z < 1$	93,100
PuppiTau-Puppi E_T^{miss}	55(38),190(118)	4	$ \eta < 2.1$	90,100
VBF seeds				
Double PuppiJets	160,35	40	$ \eta < 5, m_{jj} > 620$	100
B-physics seeds				
Double TkMuon	2,2	12	$ \eta < 1.5, \Delta R < 1.4,$ $q1 * q2 < 0, \Delta z < 1$	95
Double TkMuon	4,4	21	$ \eta < 2.4, \Delta R < 1.2$ $q1 * q2 < 0, \Delta z < 1$	95
Double TkMuon	4.5,4	10	$ \eta < 2.0, 7 < m_{\mu\mu} < 18,$ $q1 * q2 < 0, \Delta z < 1$	95
Triple TkMuon	5,3,2	7	$0 < m_{\mu5\mu3,q1*q2<0} < 9$ $ \eta < 2.4, \Delta z < 1$	95
Triple TkMuon	5,3,2.5	6	$5 < m_{\mu5\mu2.5,q1*q2<0} < 17$ $ \eta < 2.4, \Delta z < 1$	95
Rate for above Trigger seeds				346
Total Level-1 Menu Rate (+30%)				450

BACKUP: L1 trigger architecture

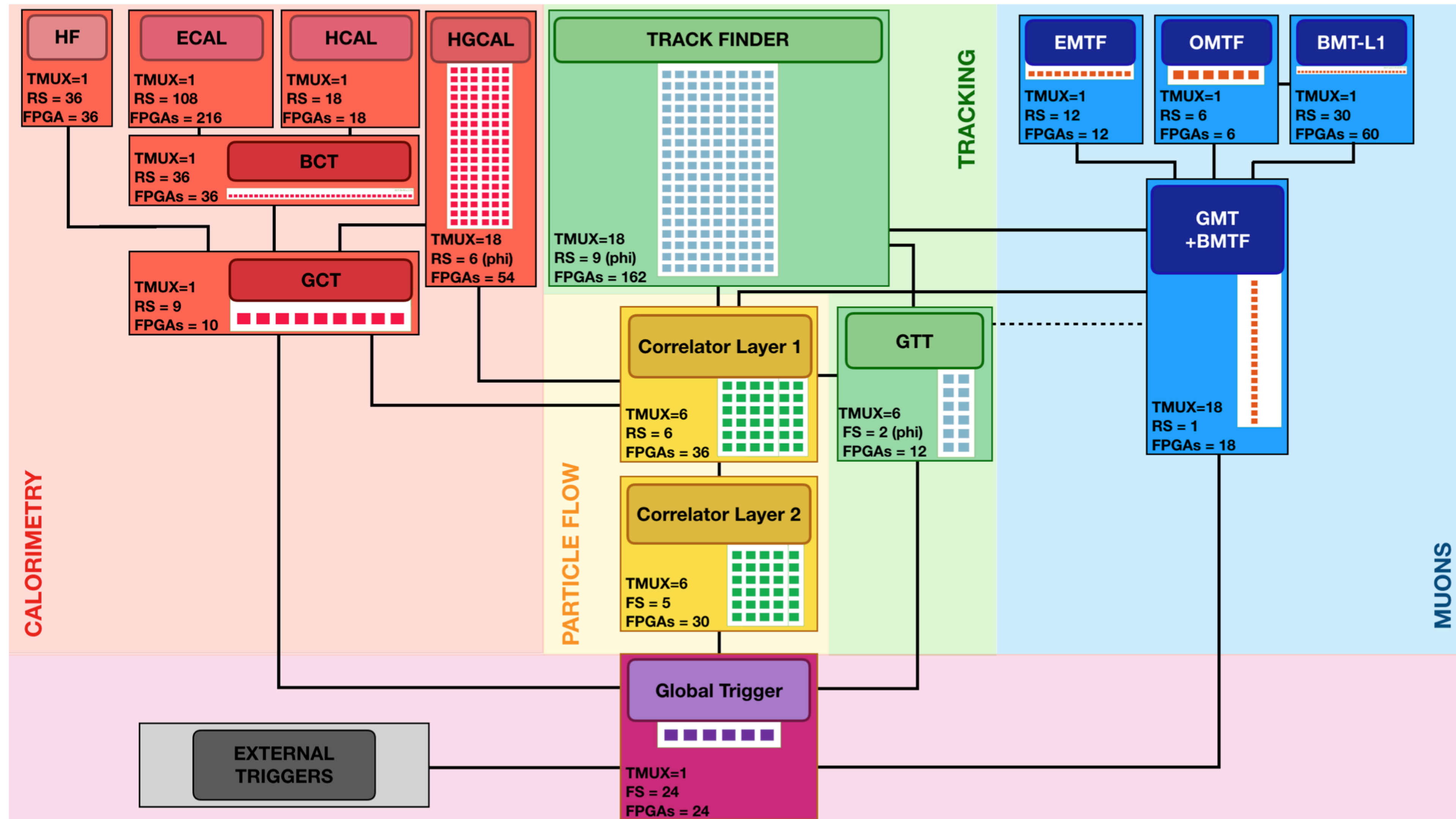

BACKUP:

L1 trigger architecture w/ 40MHz scouting

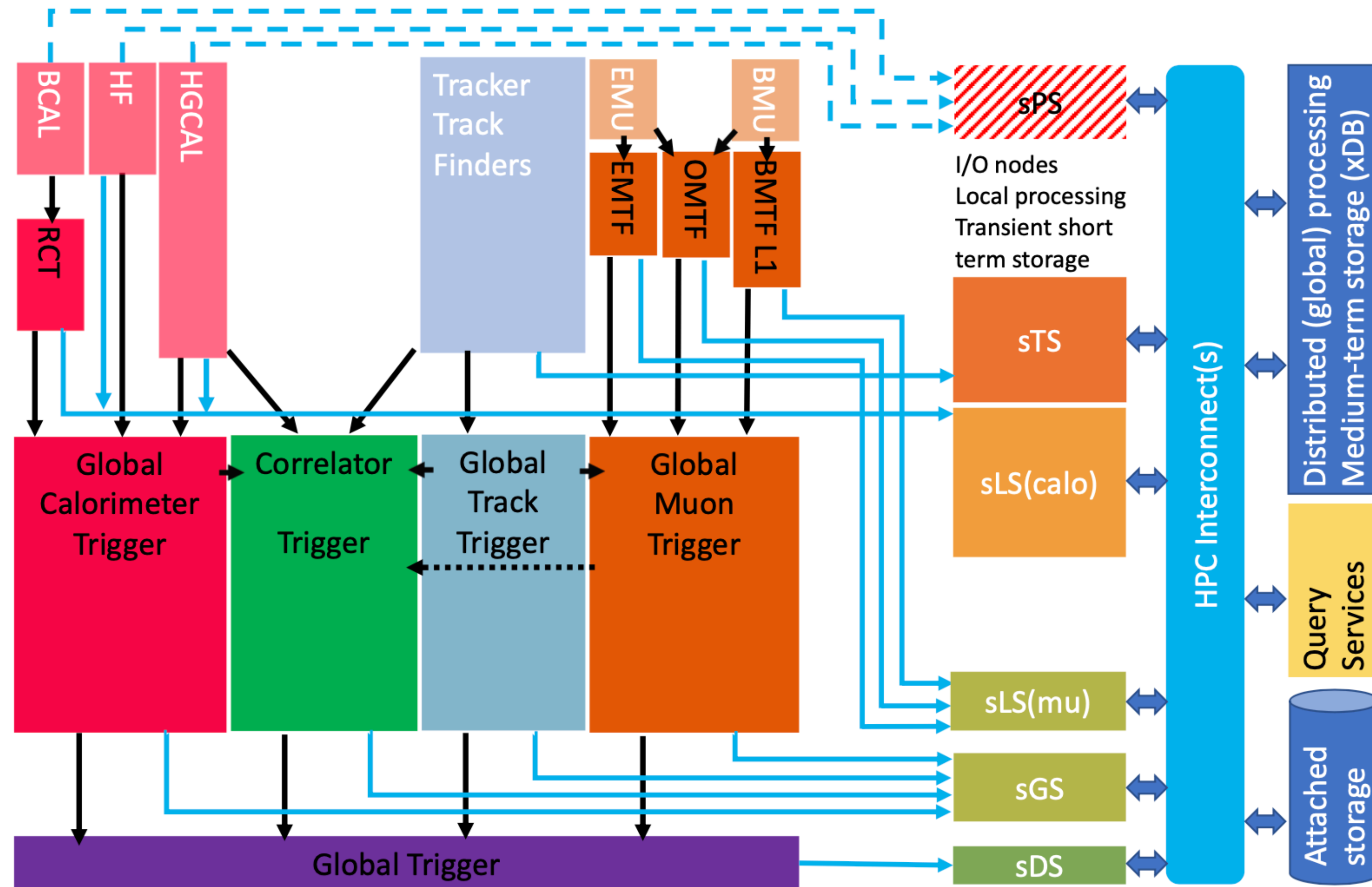

BACKUP

E_T^{miss} trigger algorithms

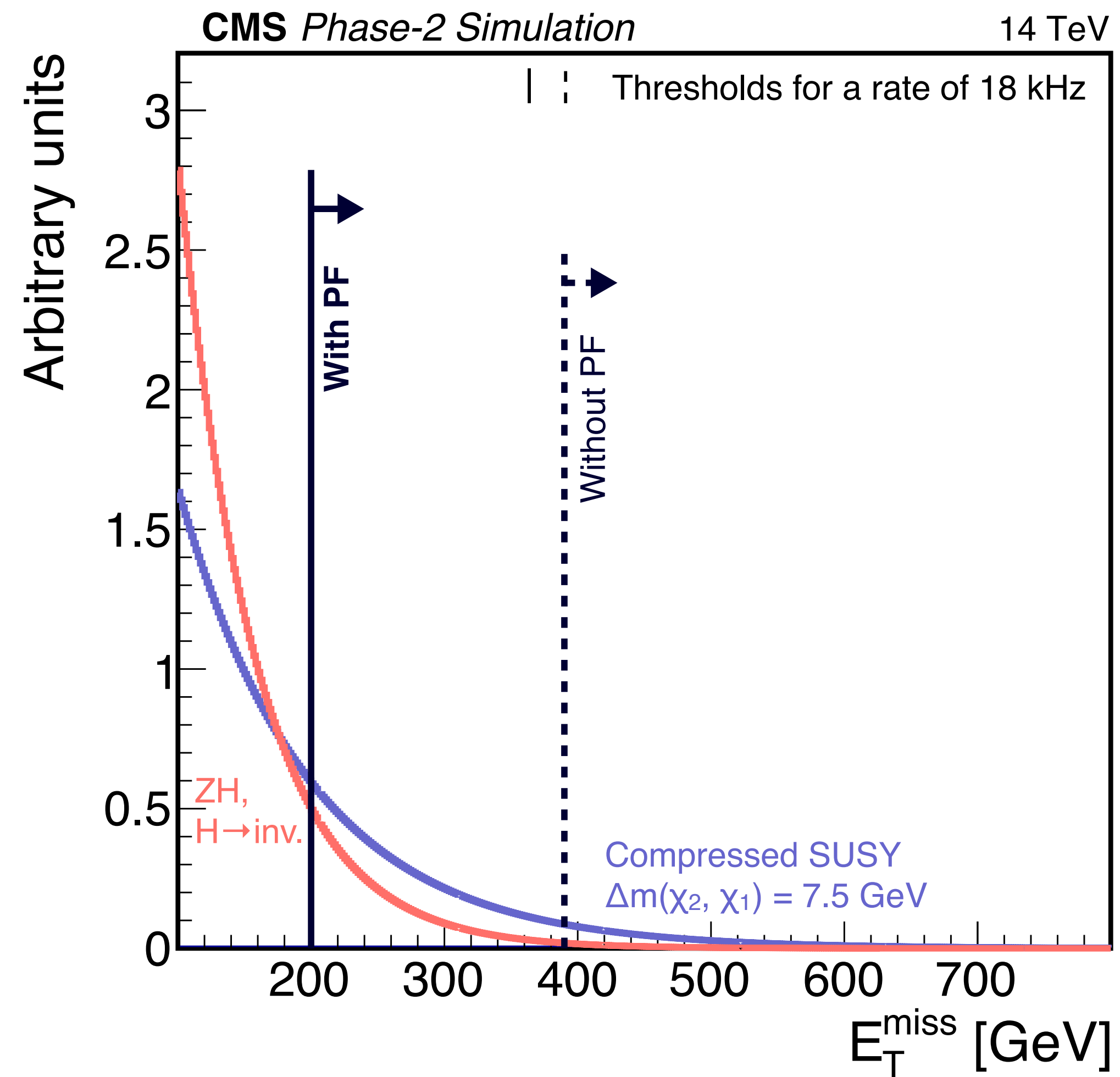

BACKUP:

e/ γ barrel performances

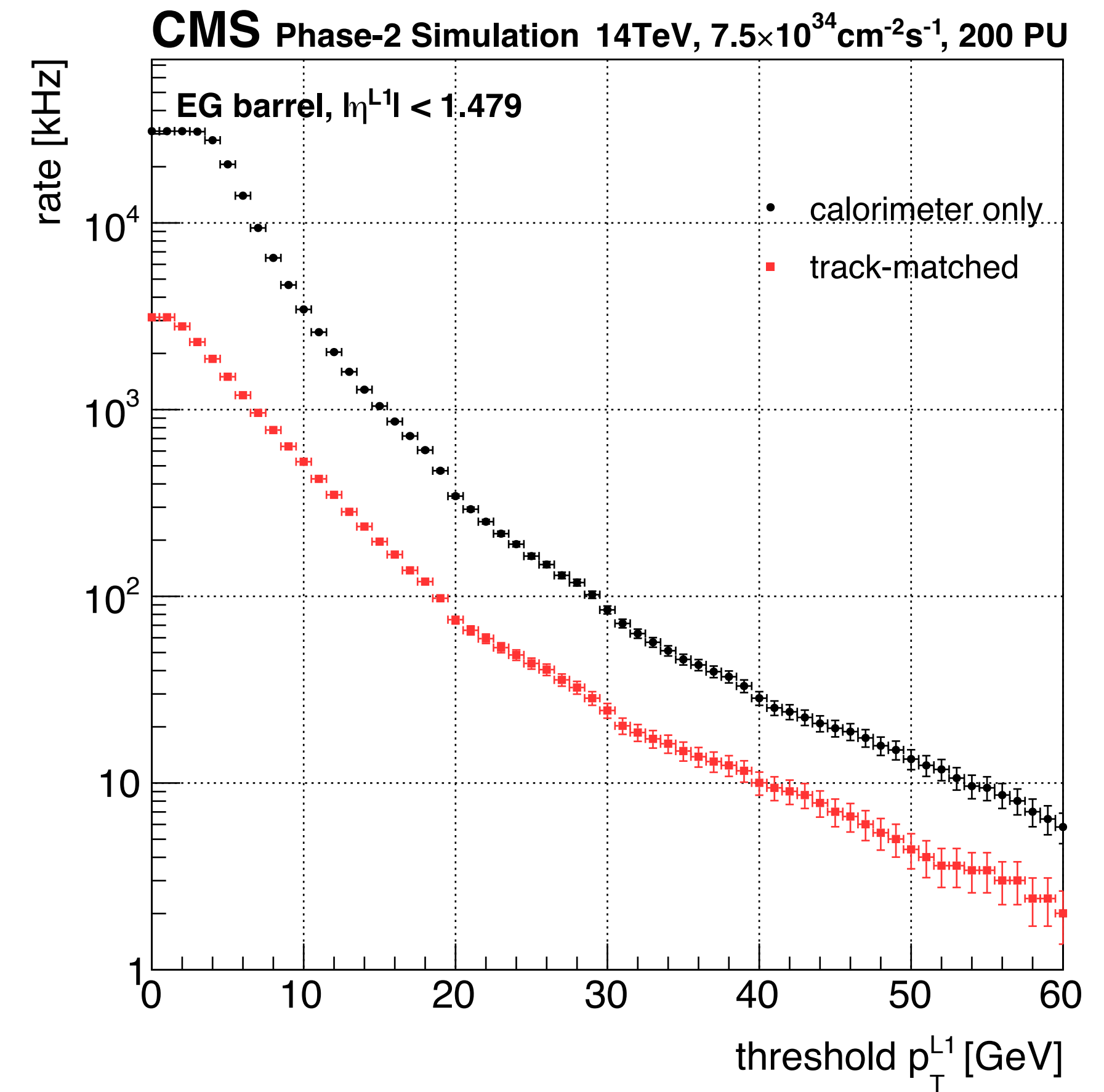
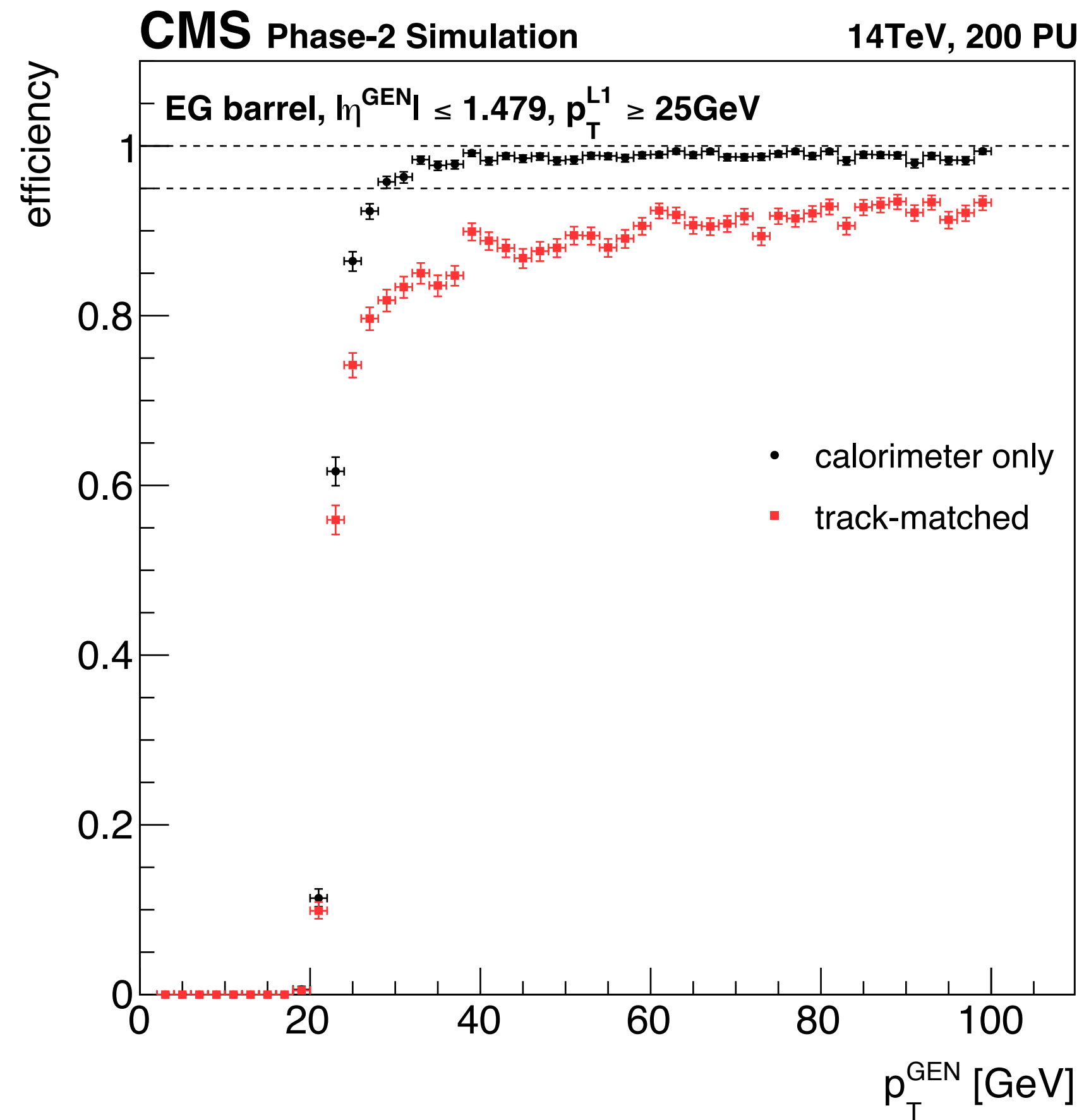

BACKUP:

e/γ endcap performances

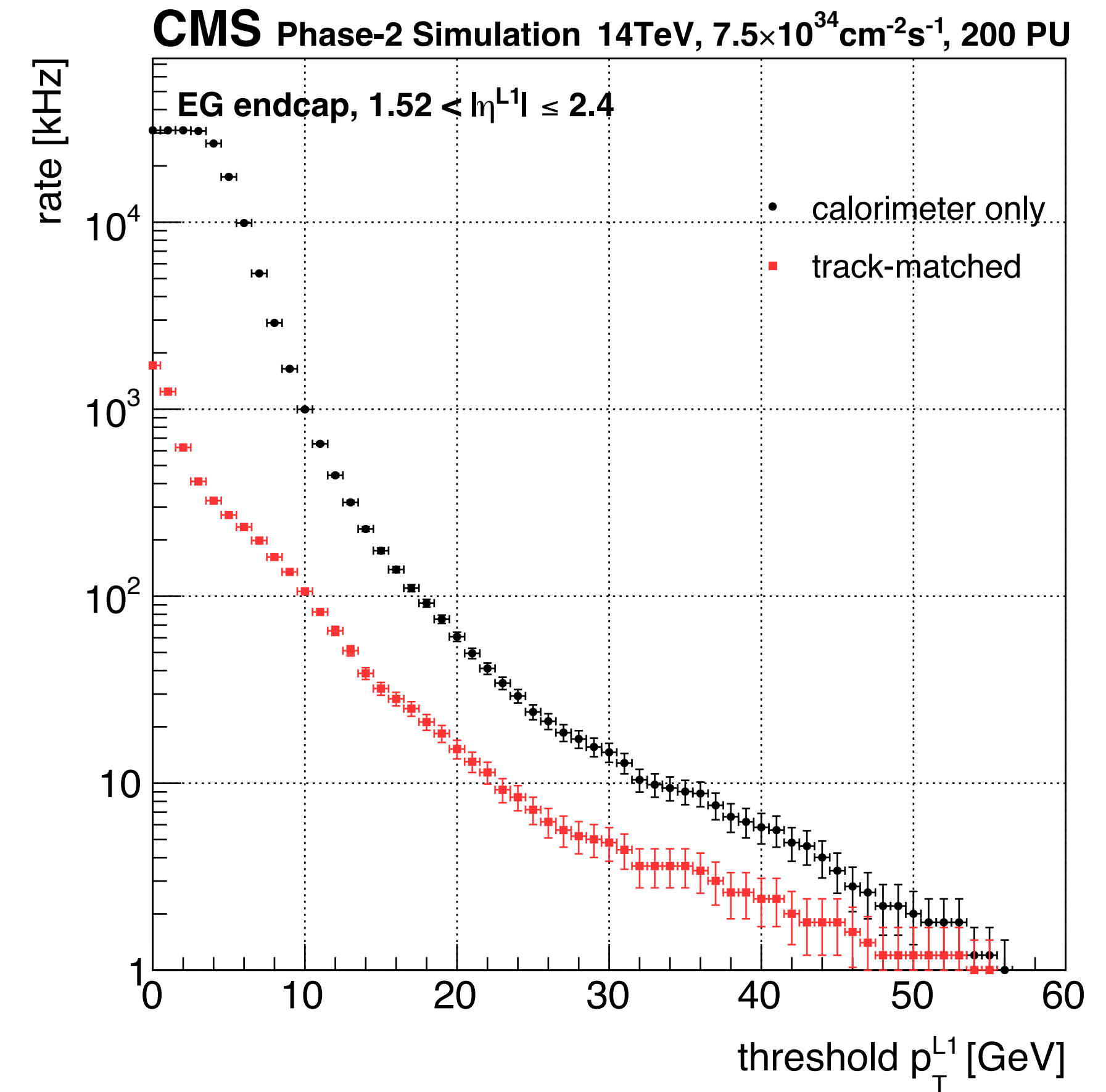
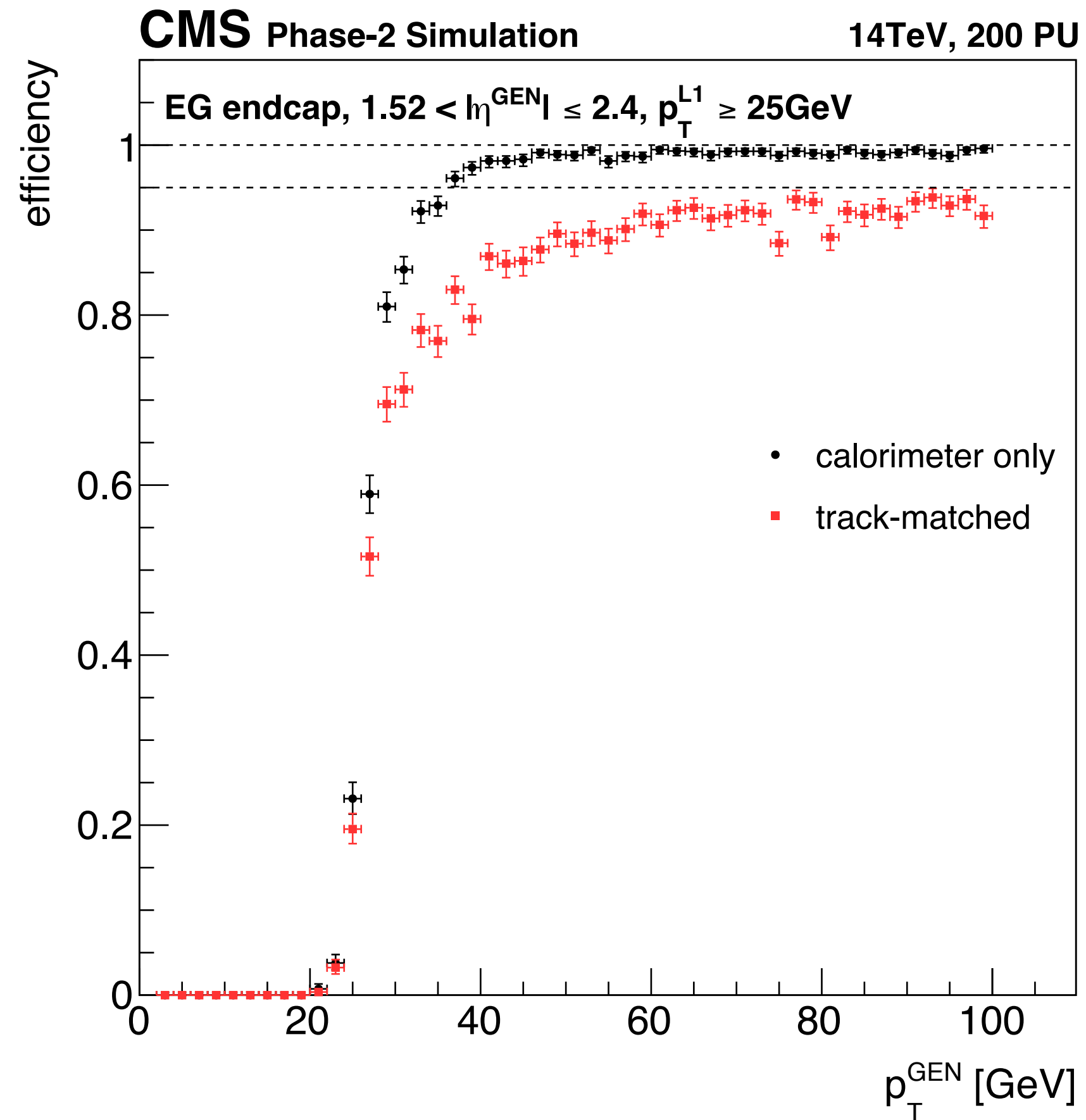

BACKUP:

μ barrel performances

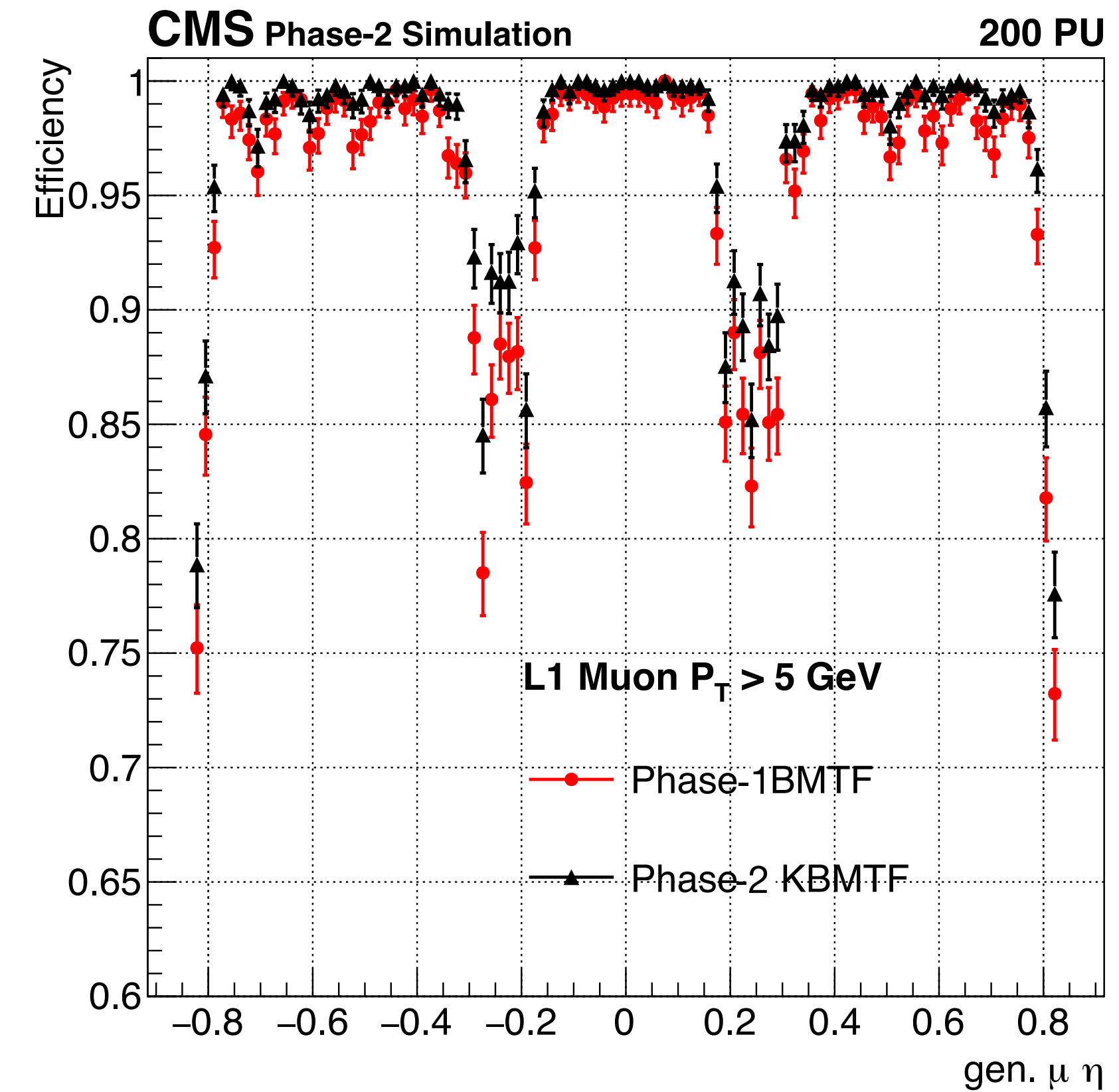
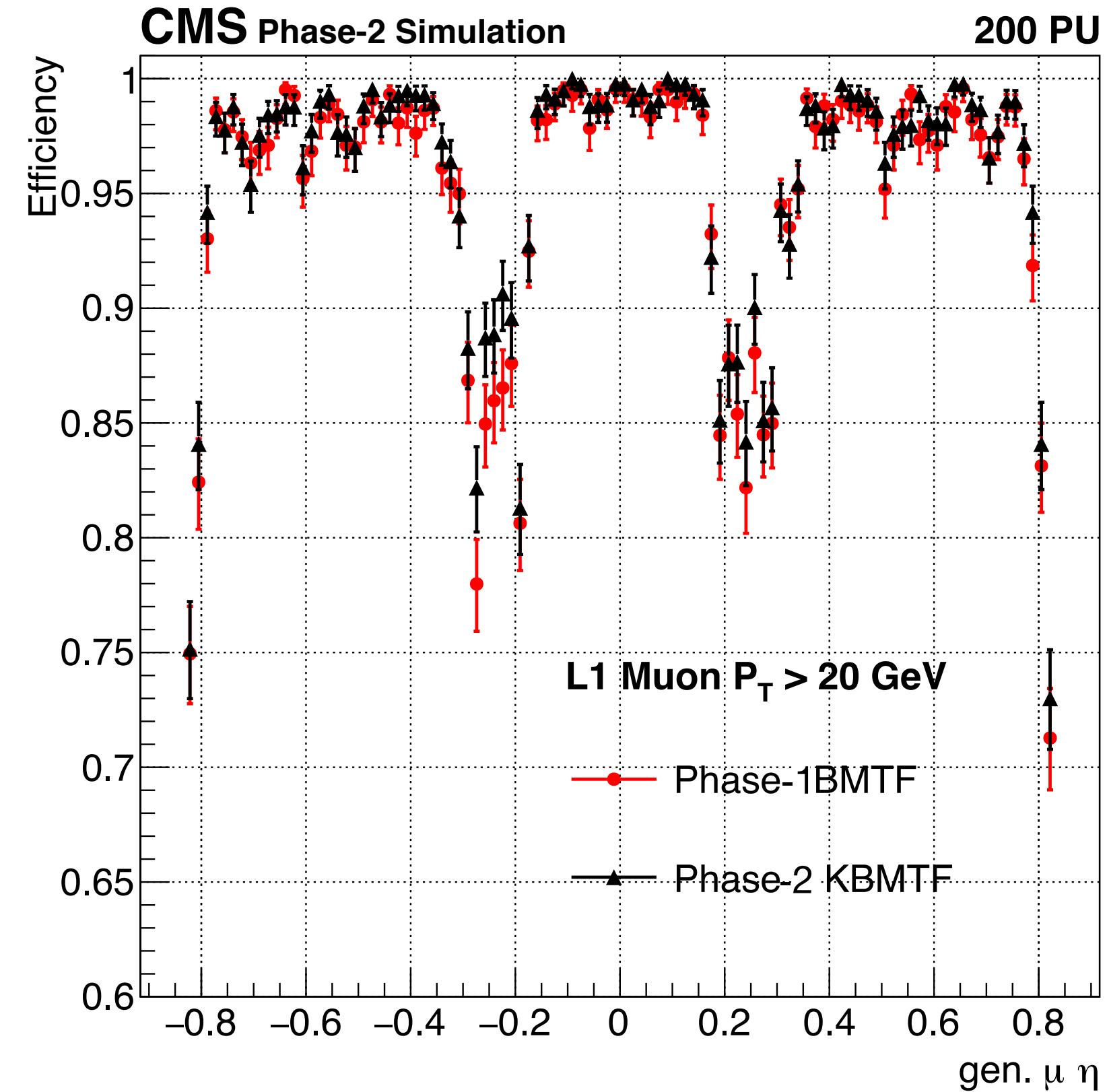
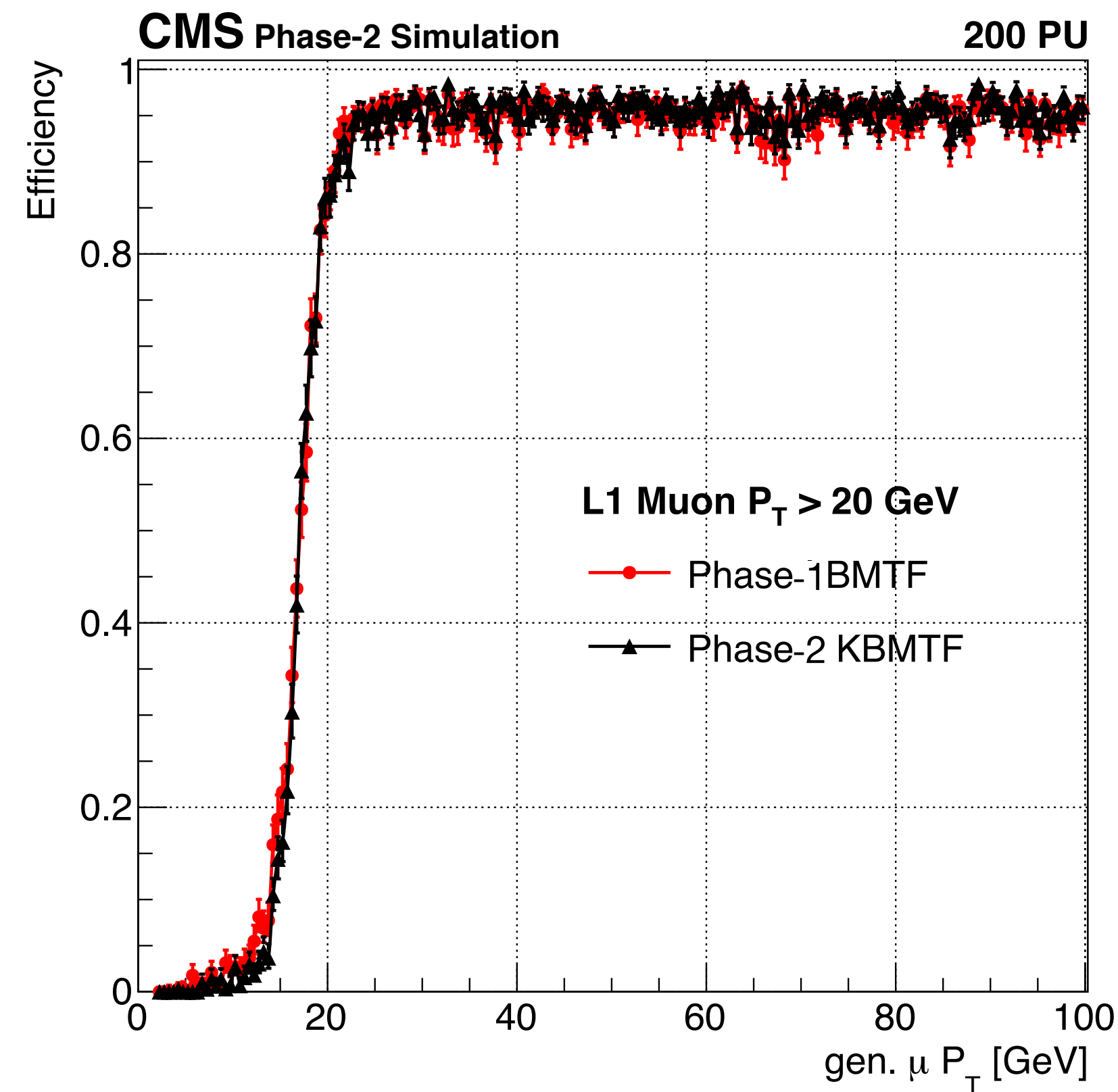

BACKUP:

μ barrel+track performances

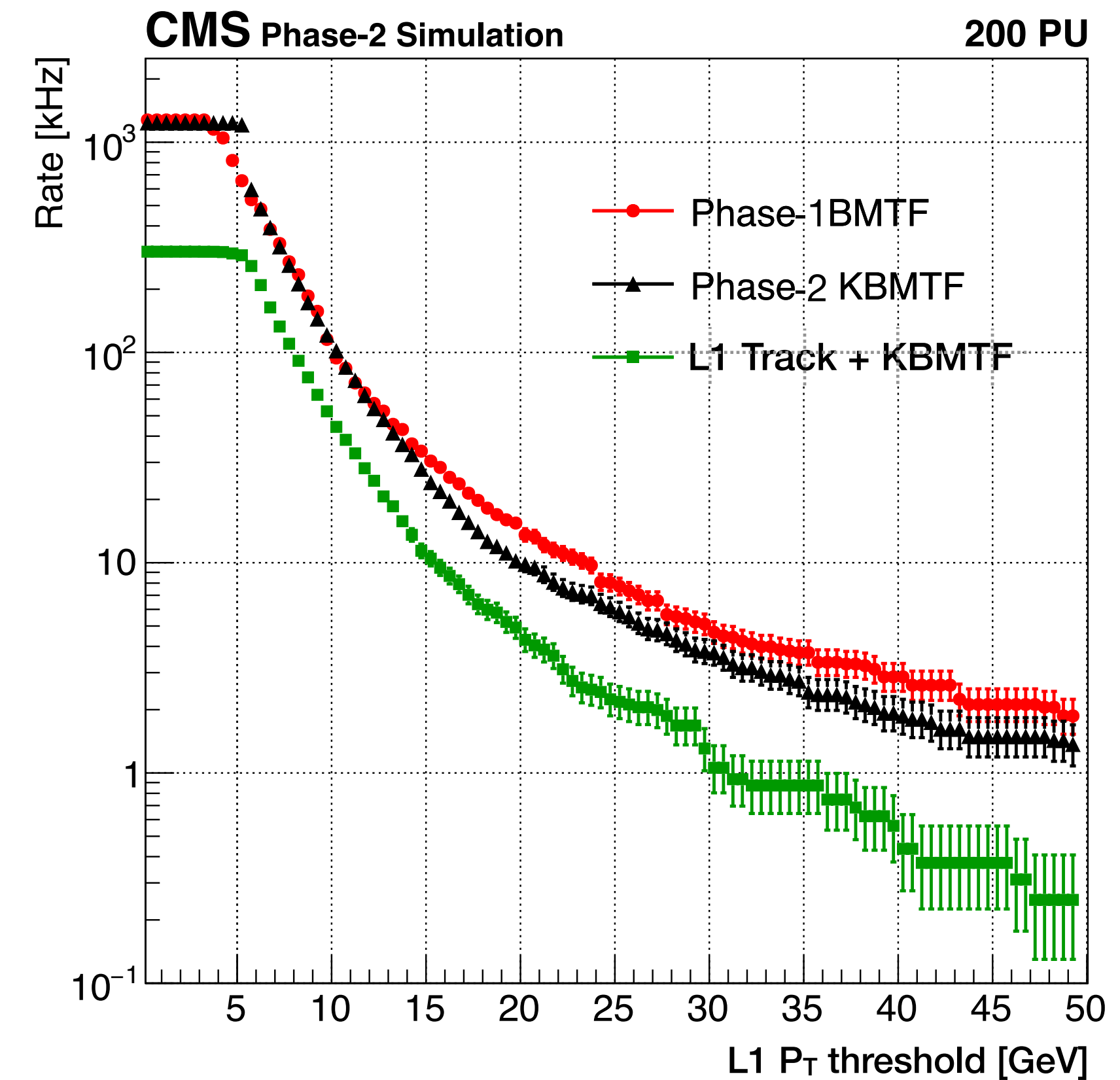
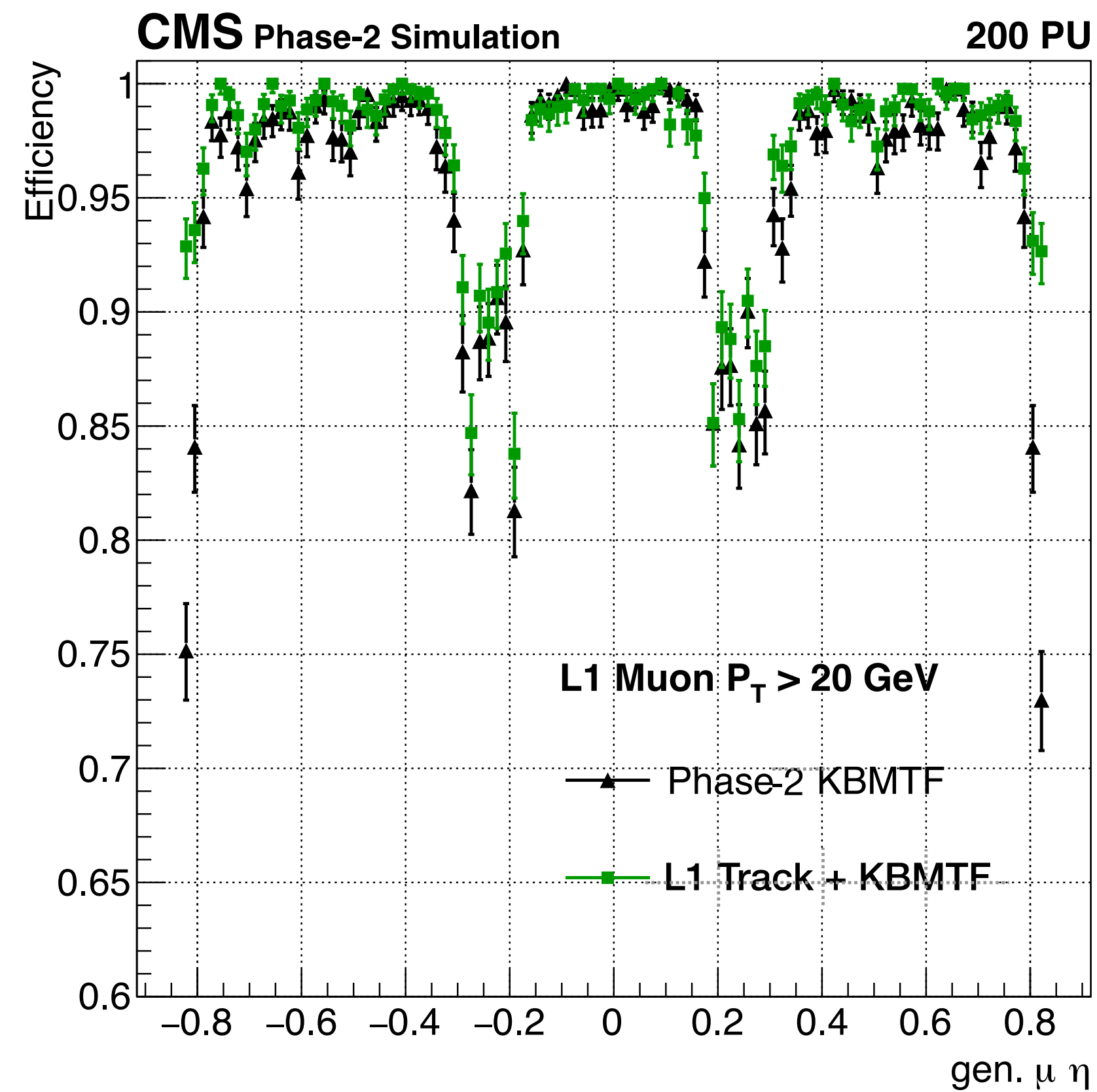
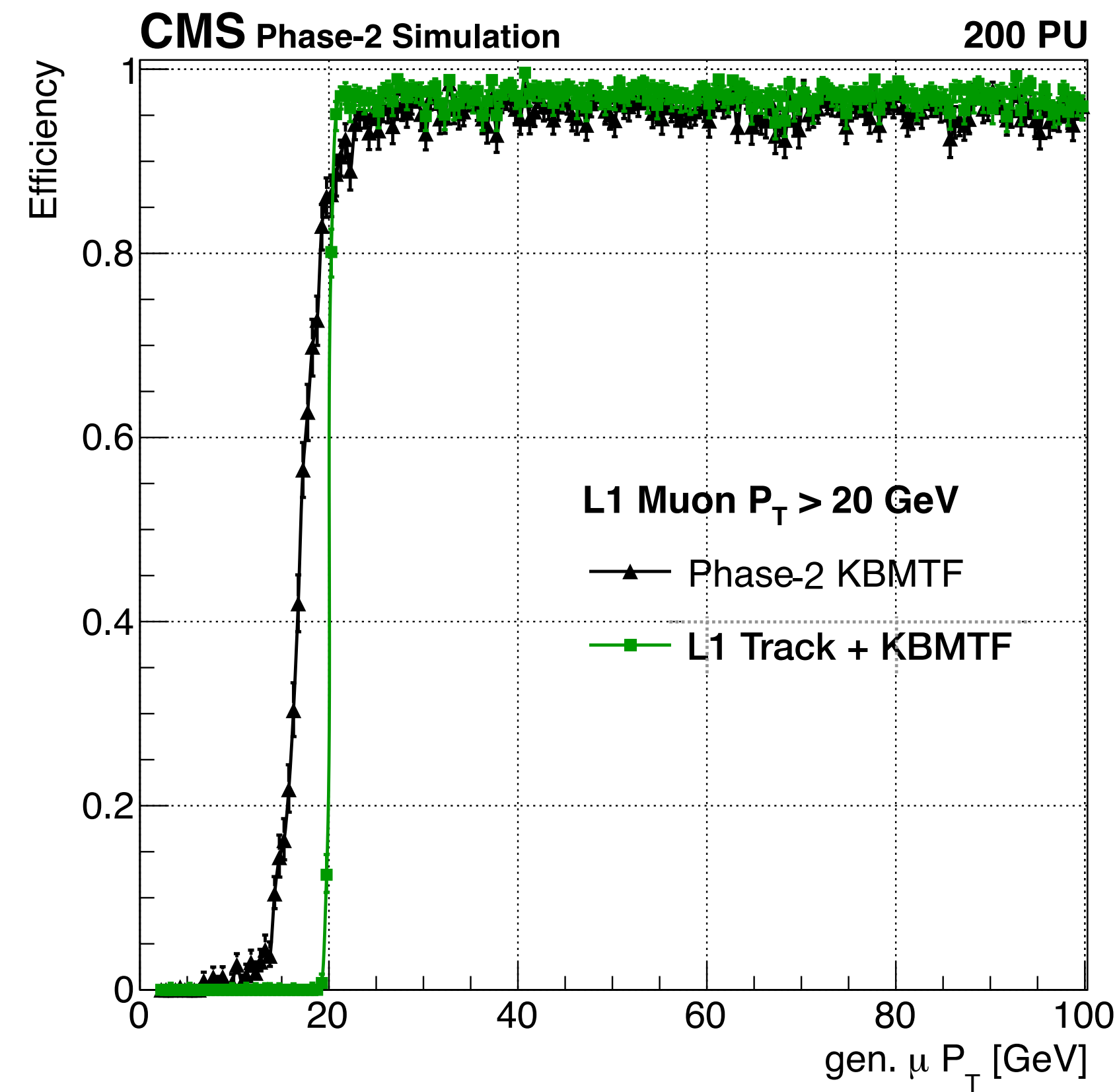

BACKUP: HGCal τ algorithm performance

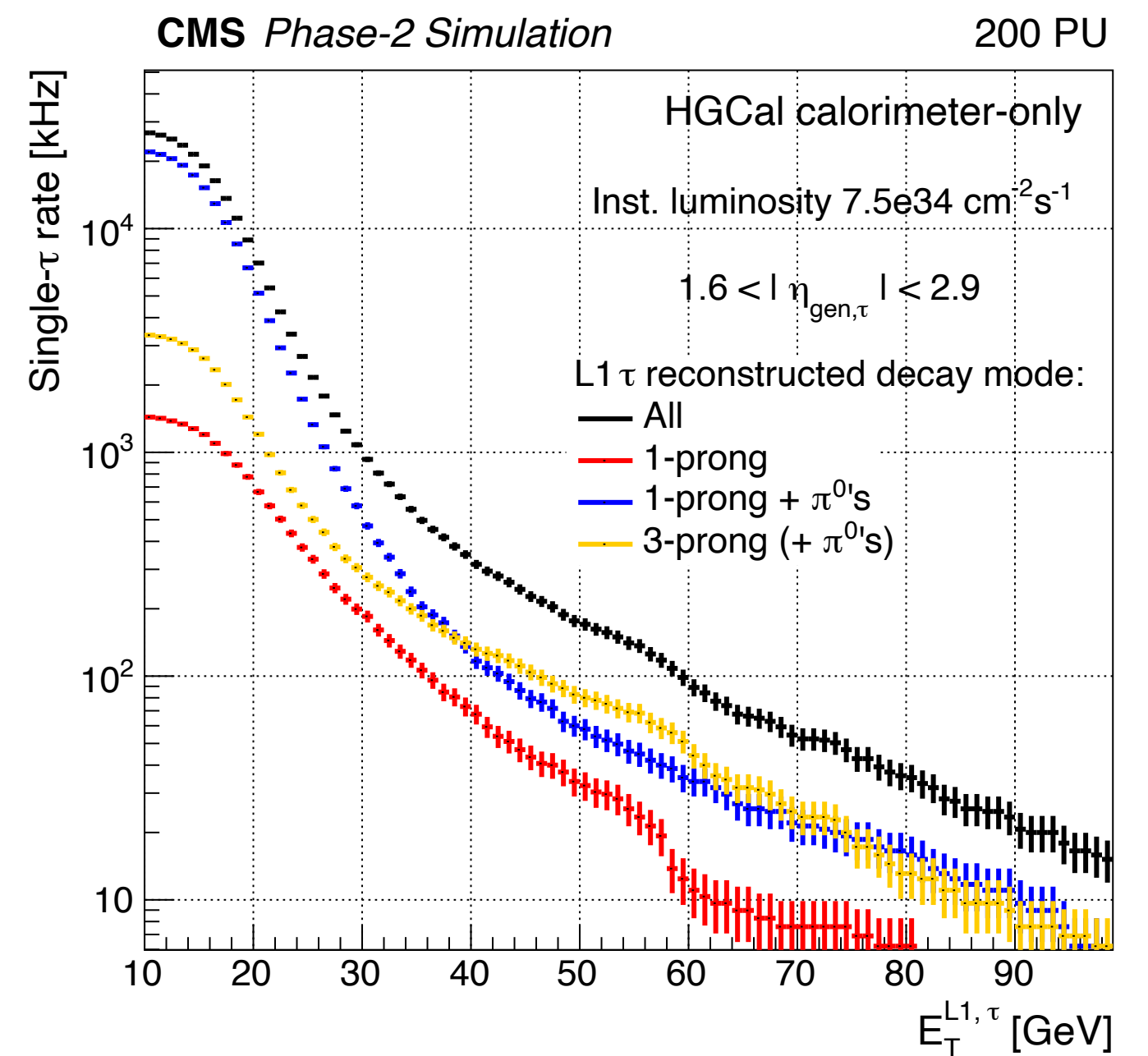
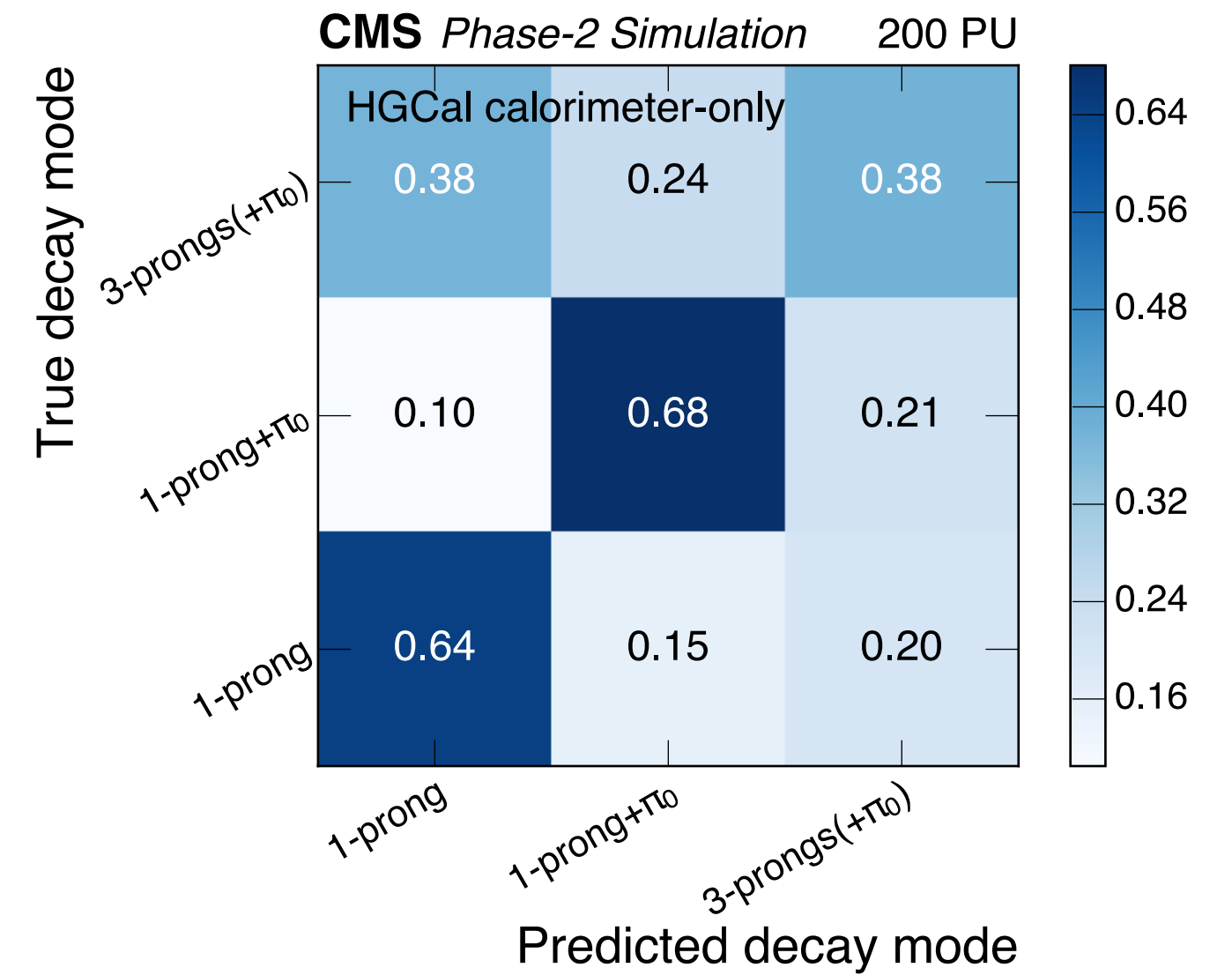
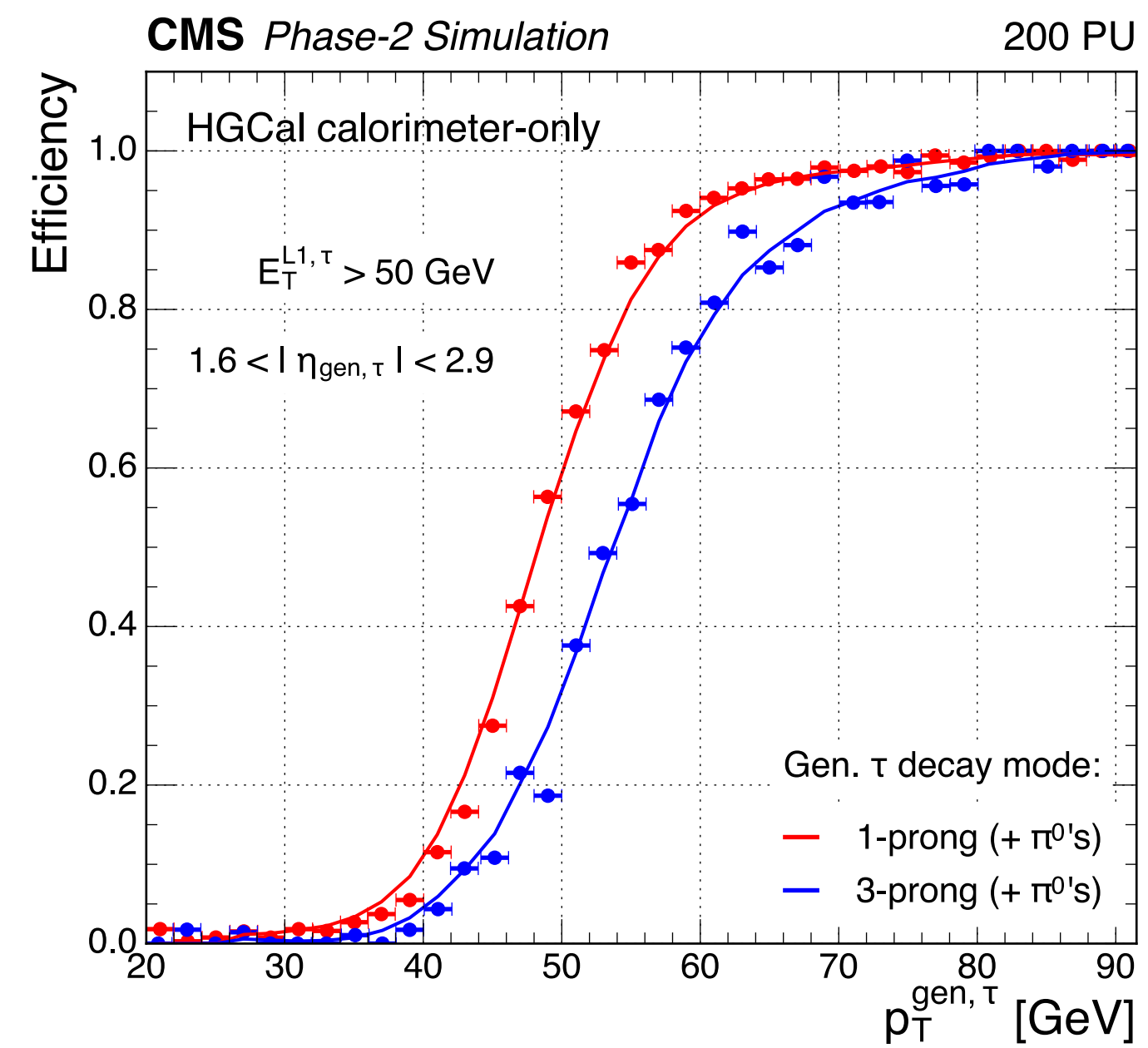
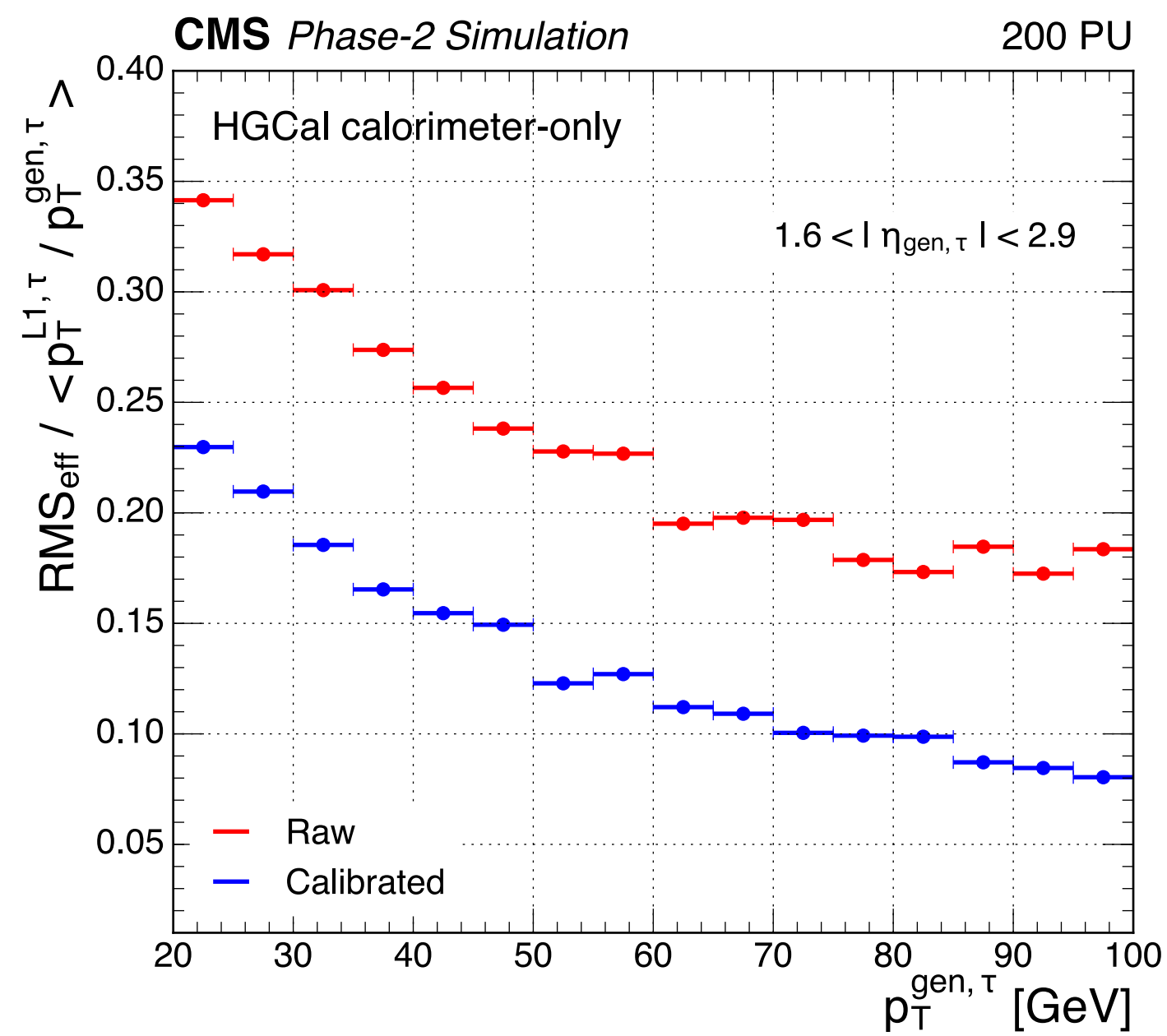

BACKUP: EMTF demonstrator

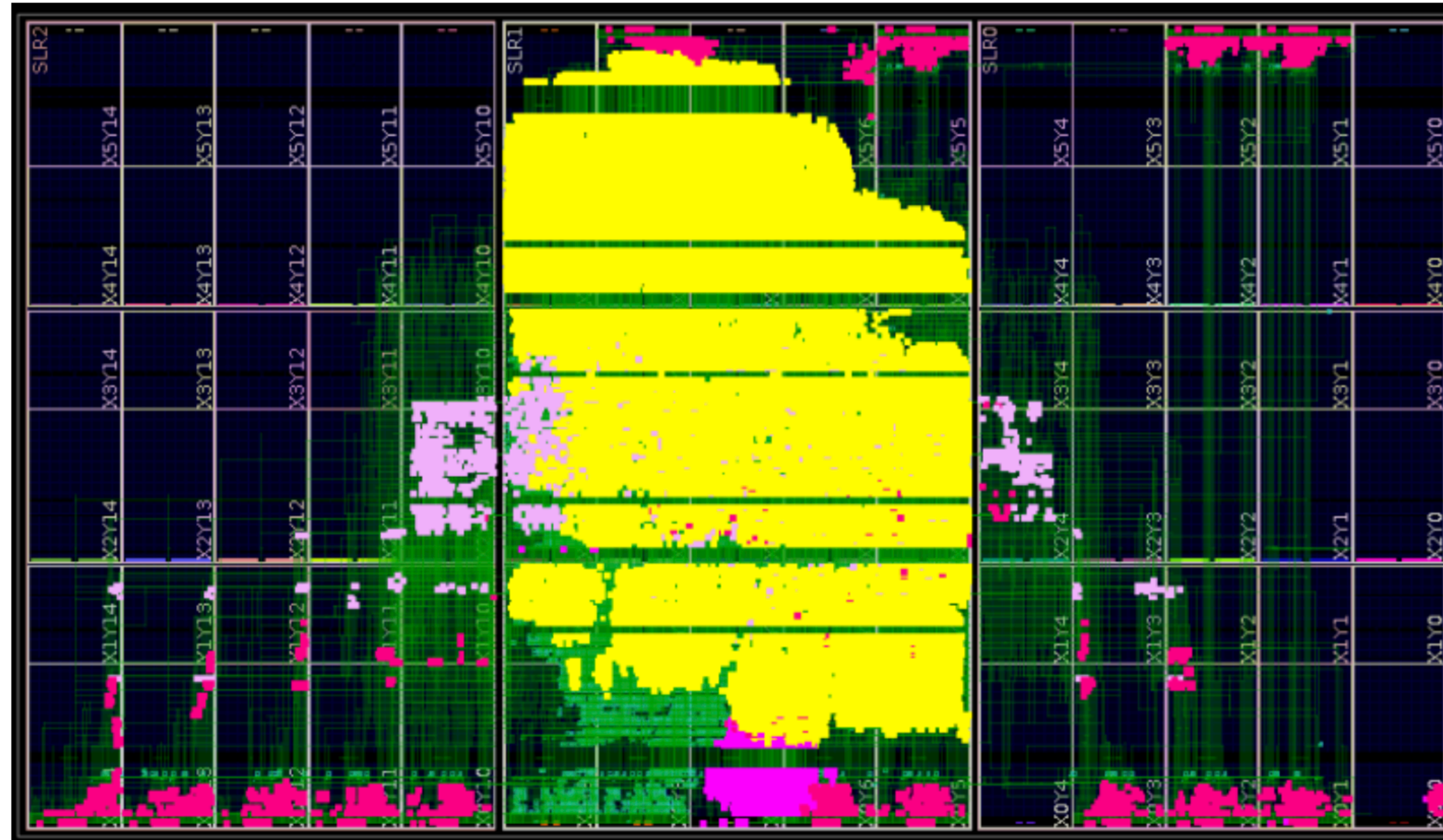

Figure 6.45: Image of the EMTF firmware usage in the Virtex 9 Ultrascale+ FPGA. Shown are the EMTF logic core (yellow), input links (red), input link data deframers (light pink), control link to the ELM2 (magenta), and other logic (green).

