

# Higgs Fermionic Couplings at CMS

Stephane Cooperstein - Princeton  
On behalf of the CMS collaboration



Lake Louise Winter Institute: February 19, 2018

# Higgs in the Standard Model

$$\mathcal{L} = -\frac{1}{4} F_{\mu\nu} F^{\mu\nu}$$

$$+ i \bar{\psi} \not{D} \psi + h.c.$$

$$+ \bar{\psi}_i y_{ij} \psi_j \phi + h.c.$$

$$+ |D_\mu \phi|^2 - V(\phi)$$

- In the Standard Model, the Higgs mechanism provides mass to the bosons and fermions.
- Yukawa couplings** proportional to fermion masses.

**Bosonic Couplings**

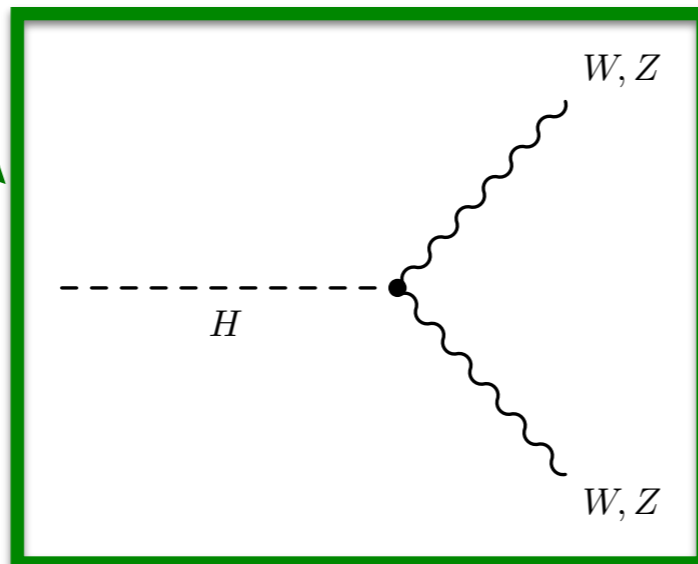

**Fermionic Couplings**

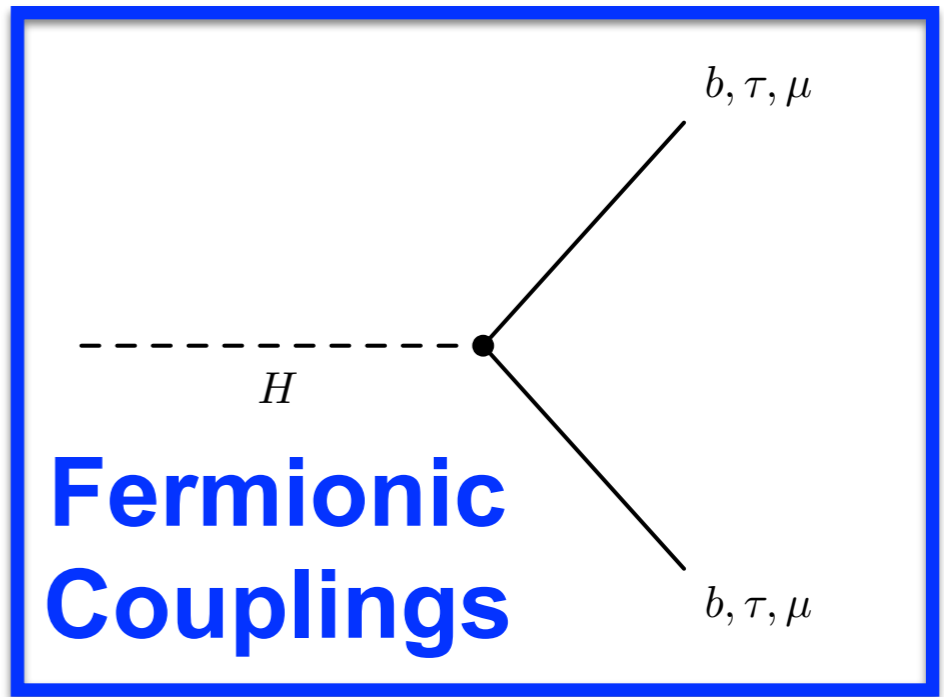

JHEP08(2016)045

- **What we know so far**
  - Higgs was discovered via decays to vector bosons
  - $M_{\text{Higgs}} \sim 125 \text{ GeV}$  with  $\sim 0.2\%$  uncertainty.
  - Pure scalar is favored with width less than 20 MeV at 95% CL.
- **Direct measurements of Higgs Yukawa couplings suffer from relatively larger uncertainties than other Higgs measurements.**
  - Any deviation from SM prediction would hint to new physics.

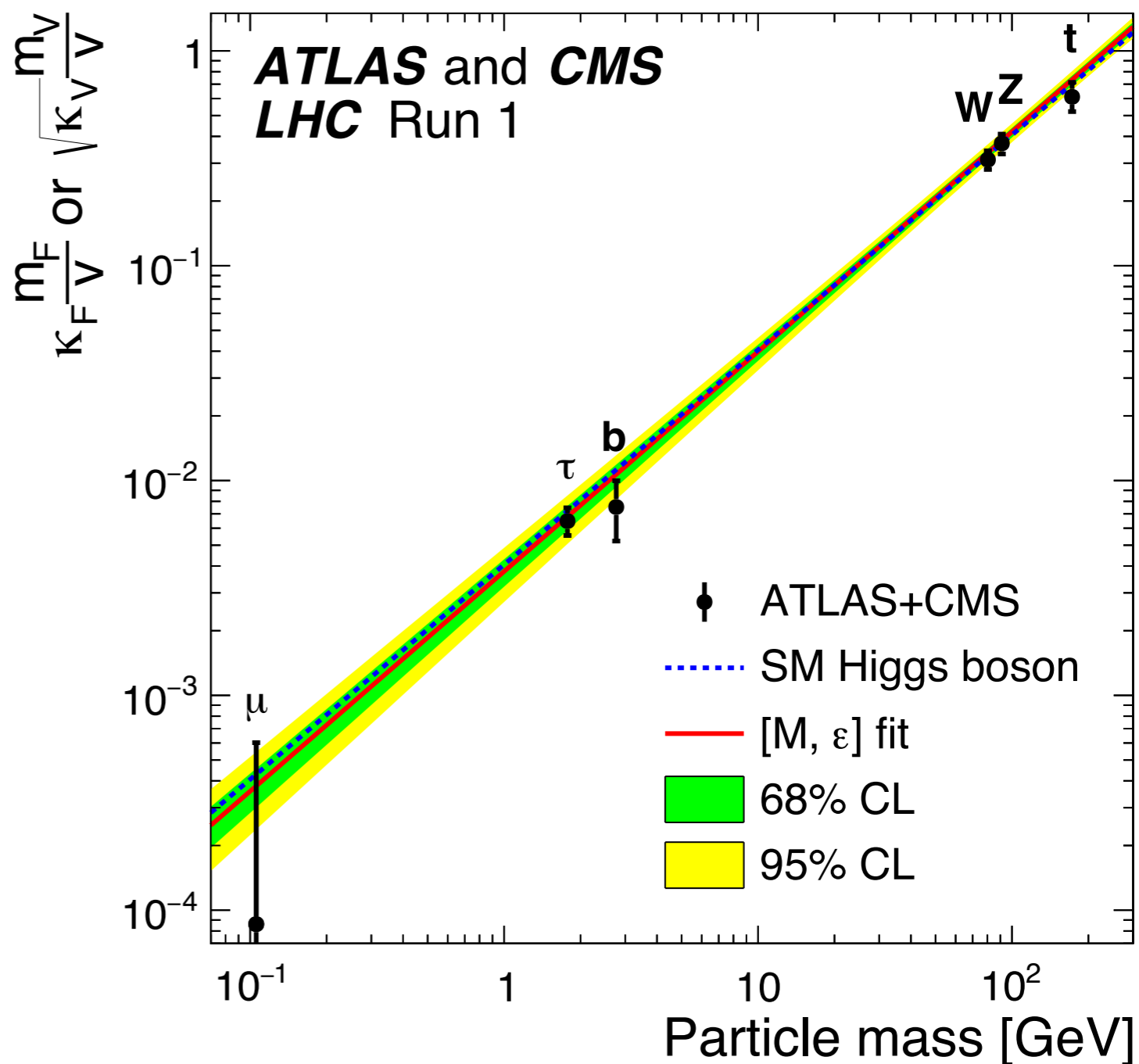

We can extract **Yukawa coupling directly from Higgs decays to fermions:**

- $H \rightarrow b\bar{b}$ : (BR=58%, large background)
- $H \rightarrow \tau^+\tau^-$ : (BR = 6% but cleaner signature)
- $H \rightarrow \mu^+\mu^-$ : (BR = 0.02%)

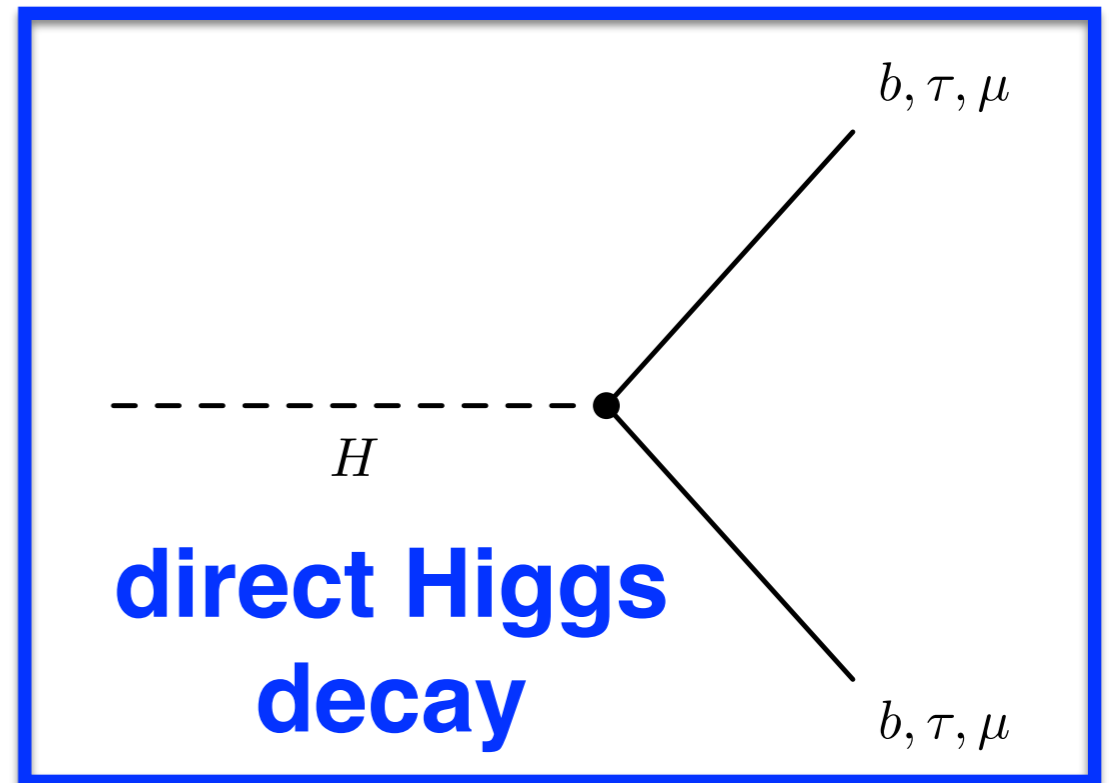

We can also **directly probe  $Y_t$  by measuring the  $t\bar{t}H$  production cross section.**

- Combine  $t\bar{t}H$  measurement among various Higgs decay modes.

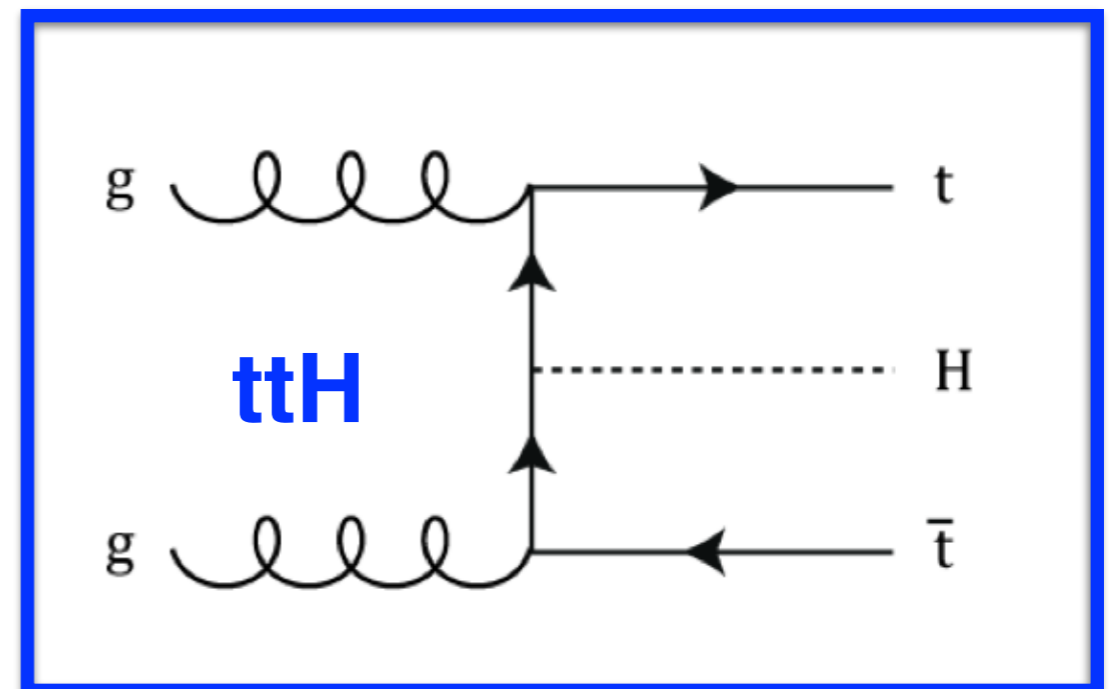

# H → b $\bar{b}$

## proton - (anti)proton cross sections

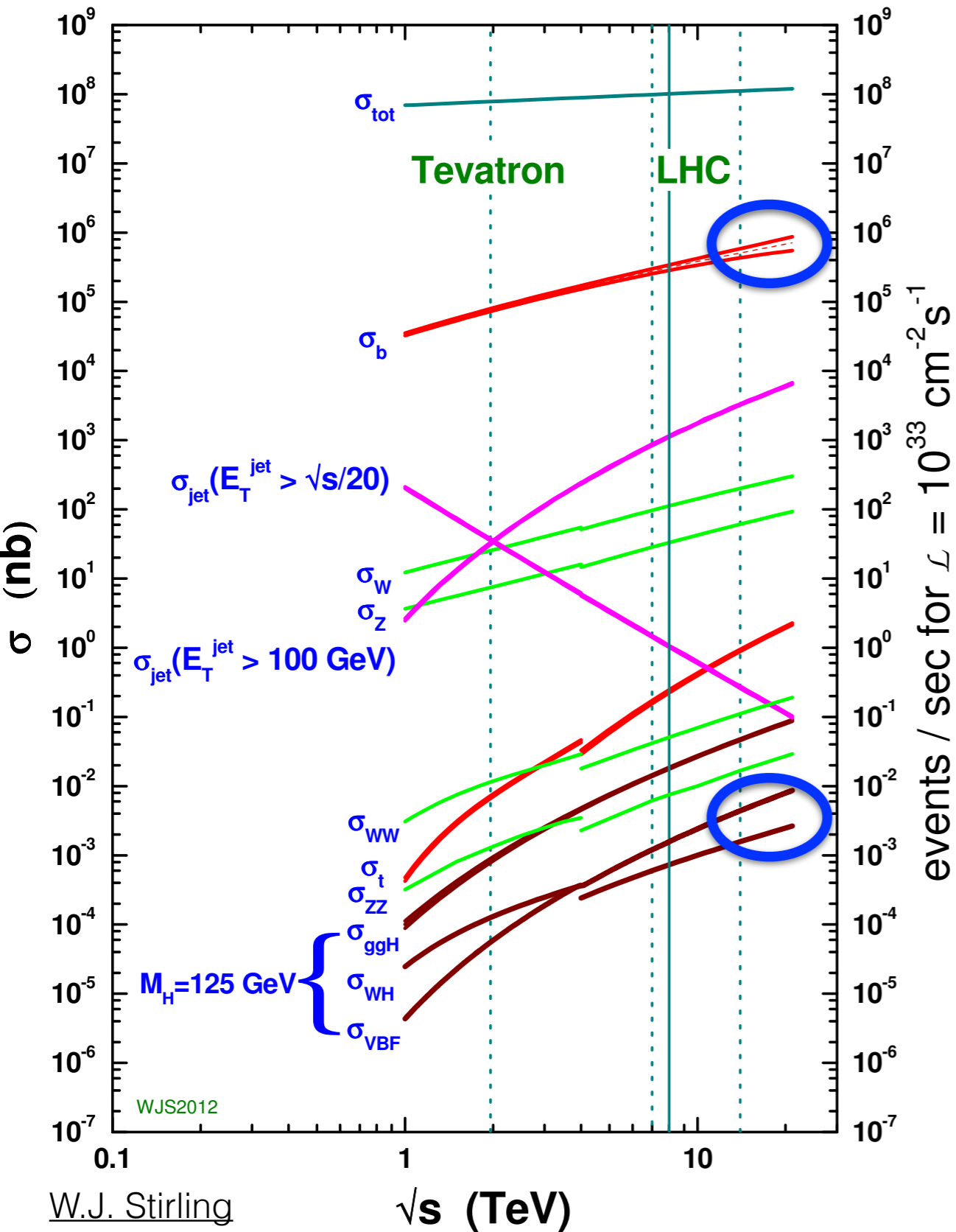

- Searching for  $H \rightarrow b\bar{b}$  at the LHC very difficult due to overwhelming multi-jet background.
- Make use of vector boson associated (VH) production: leptonic V decay provides important handle on background and simple trigger strategy.

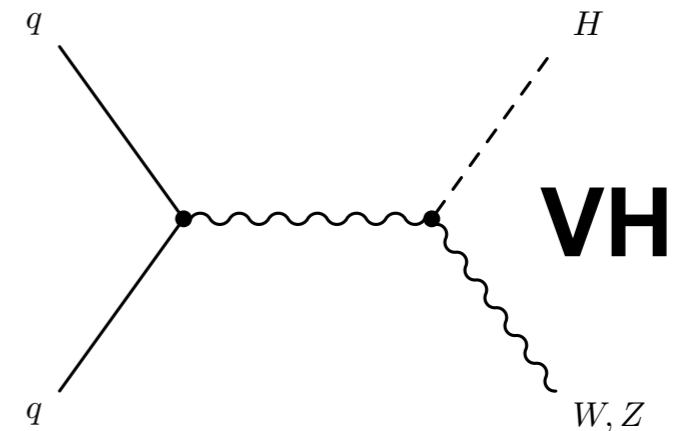

- Consider exclusively high- $p_T(H)$  regime exploiting jet substructure techniques.

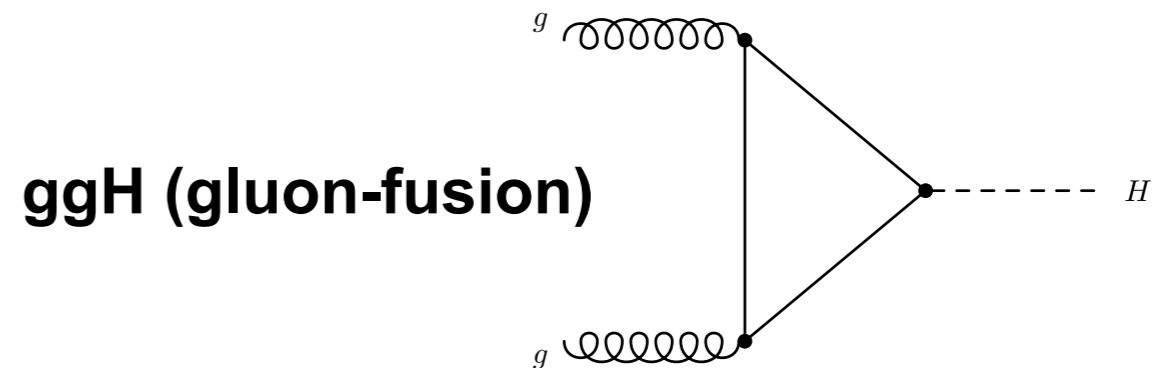

# VH, $H \rightarrow b\bar{b}$ : Analysis Techniques

- **“Boosted” V:**
  - Require high- $p_T$  W/Z back-to-back with respect to Higgs candidate
- **Jet energy regression:**
  - Multivariate regression trained to improve  $M(bb)$  resolution.
- **Boosted Decision Tree (BDT)** classifier to discriminate signal from backgrounds.

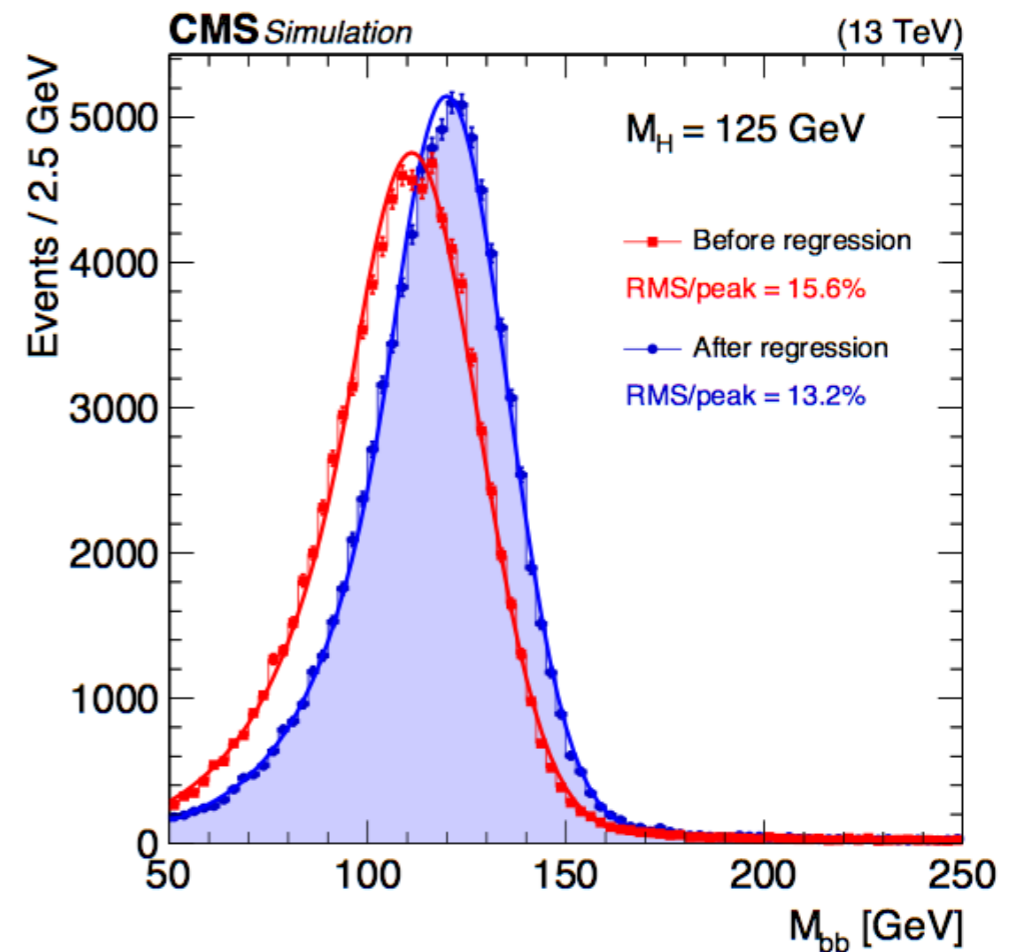
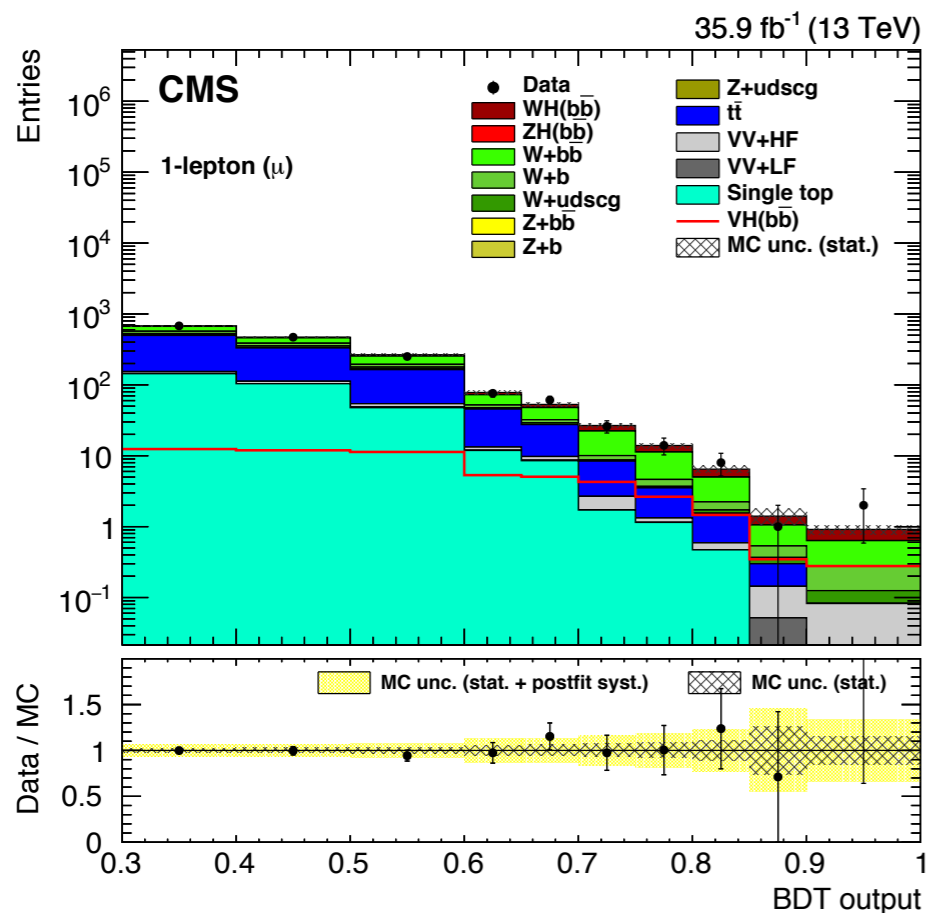
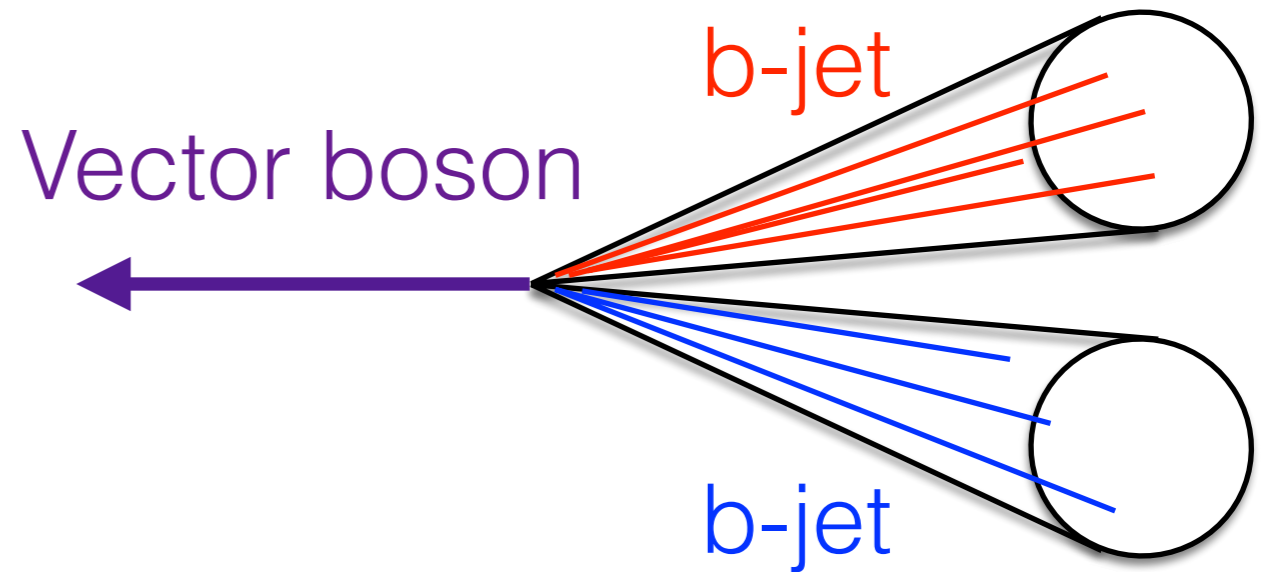

# VH, H→b $\bar{b}$ : Results

- Simultaneous fit of BDT distribution in Z(ll), Z(vv), and W(lv) channels.

$$\mu = 1.19^{+0.21}_{-0.20} (stat)^{+0.34}_{-0.32} (syst)$$

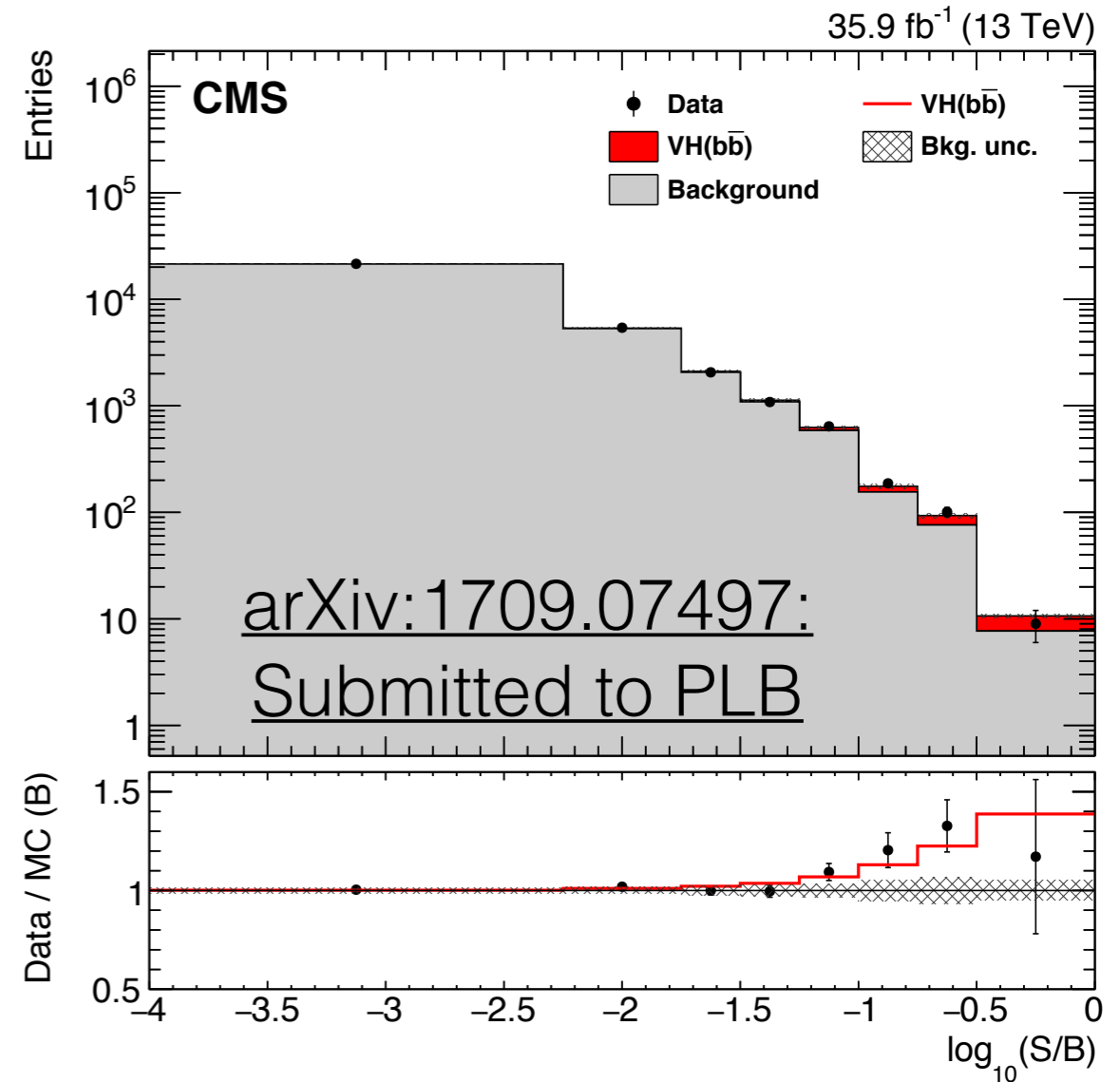
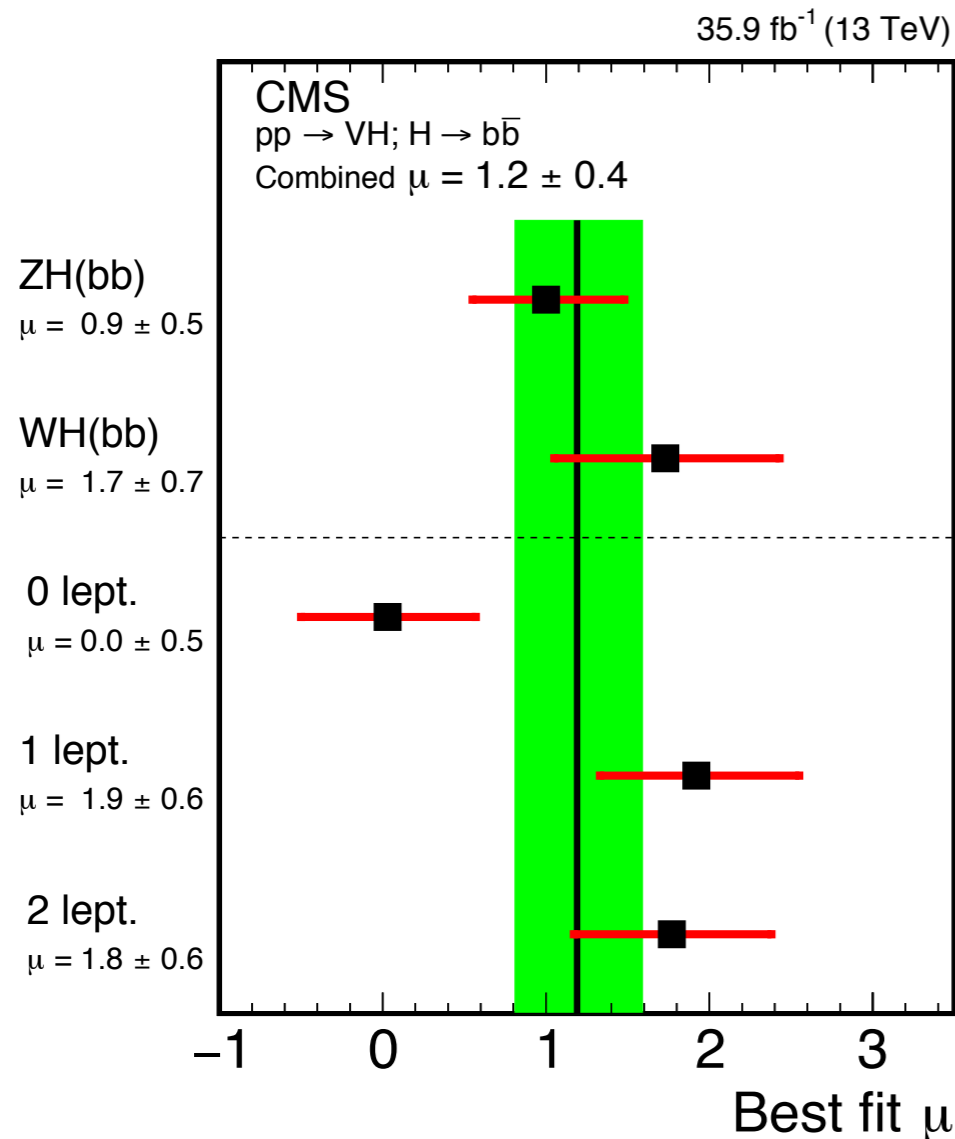

- **Evidence for H→b $\bar{b}$ !**

- 30% precision on signal strength (3.8 $\sigma$ ) when combined with Run-1 result.

significance  
2.8 $\sigma$  expected  
3.3 $\sigma$  observed

# ggH → b $\bar{b}$ at High $p_T(H)$

- b-jets increasingly likely to “merge” with increasing  $p_T(H)$ .
- Uses **jet substructure techniques** to “tag” large jets which contain both b-quarks.
- **First observation ( $5.1\sigma$ ) of  $Z \rightarrow b\bar{b}$  in single merged jet topology!**
- New contribution to Higgs differential measurement at high  $p_T(H)$ .

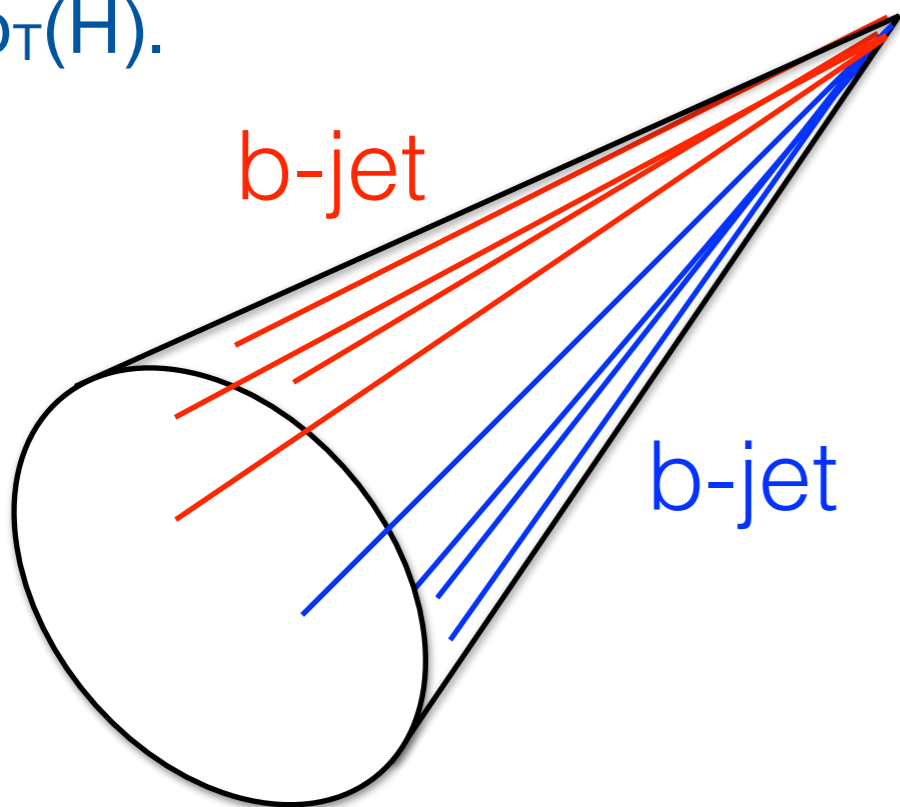

- Previously thought to be infeasible at LHC due to overwhelming multi-jet background.

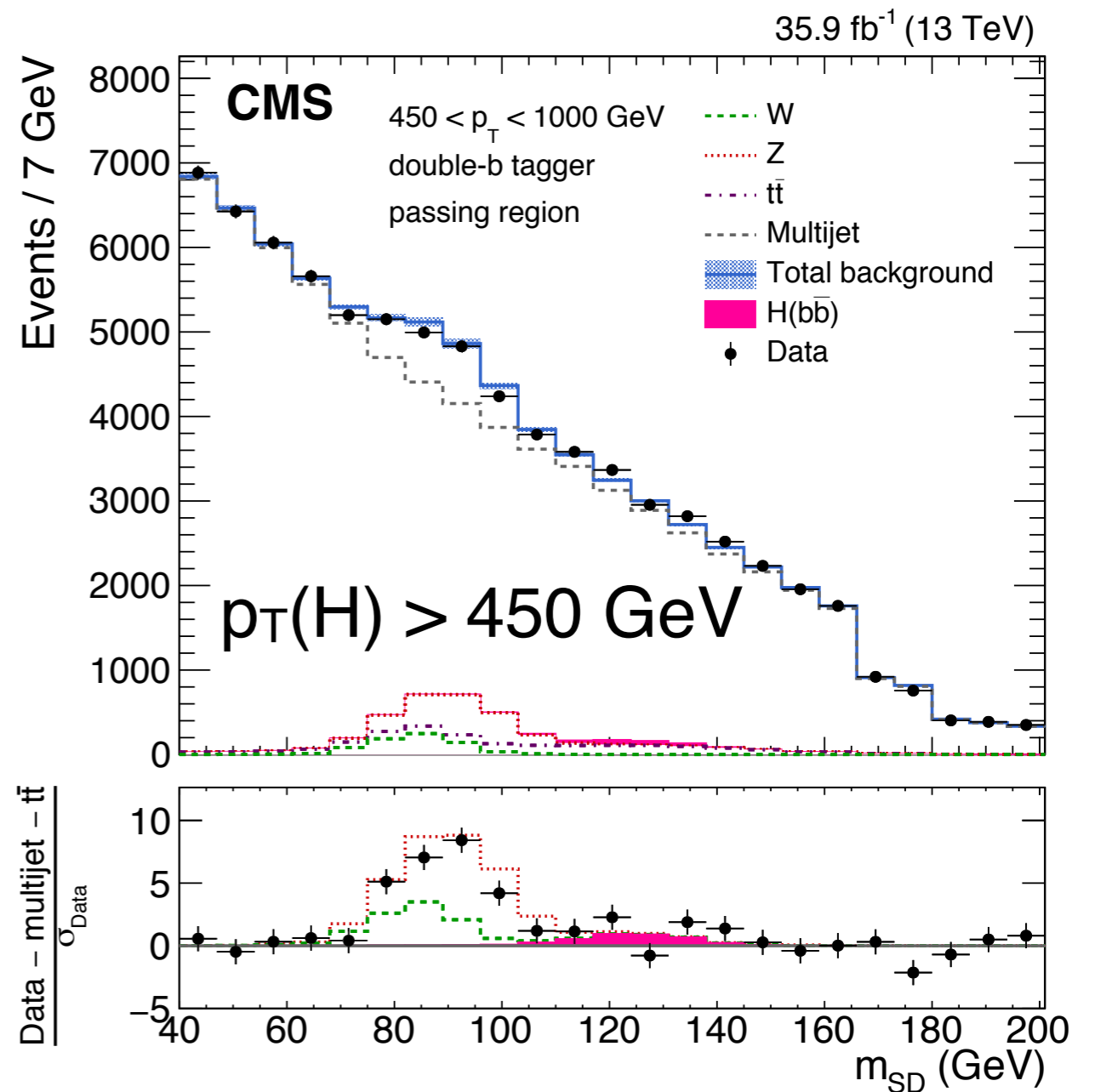

PhysRevLett.120.071802

- Higgs fermionic decay channel with **best combination of selection efficiency and background rejection.**
- Primary challenges: mass resolution, trigger.
- Events **split by  $\tau$  decay and targeted production mode:**
- **Likelihood techniques to better reconstruct  $M(\tau\tau)$ .**
  - $M(\tau\tau)$  resolution: 15-20%
  - 30% improvement in analysis sensitivity.

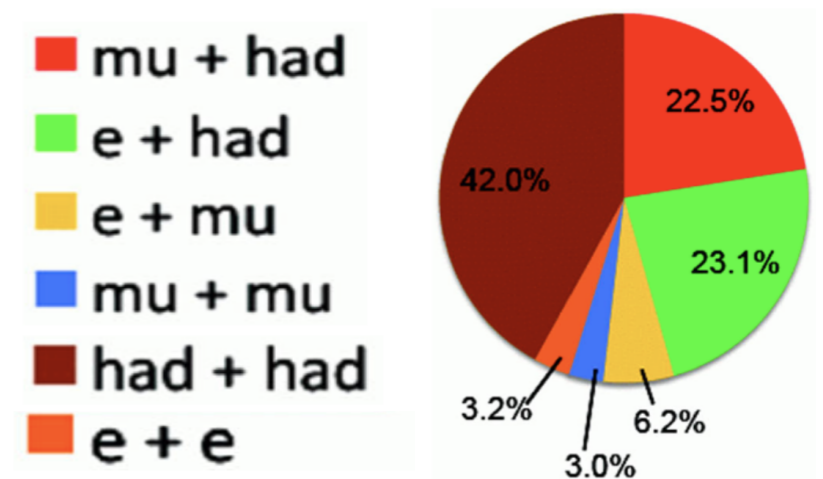
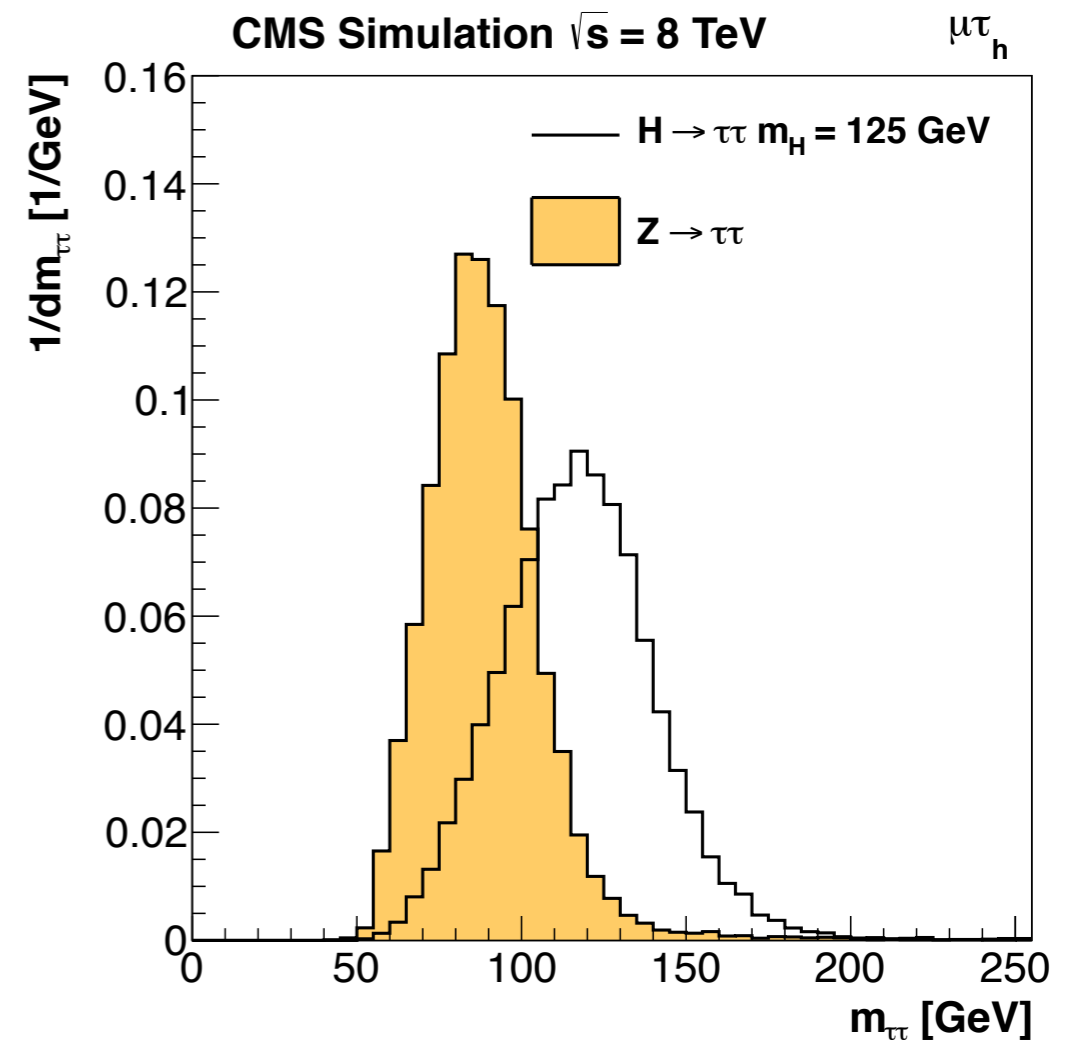

# H → τ<sup>+</sup>τ<sup>-</sup>: Results

arXiv:1708.00373:  
Submitted to PLB

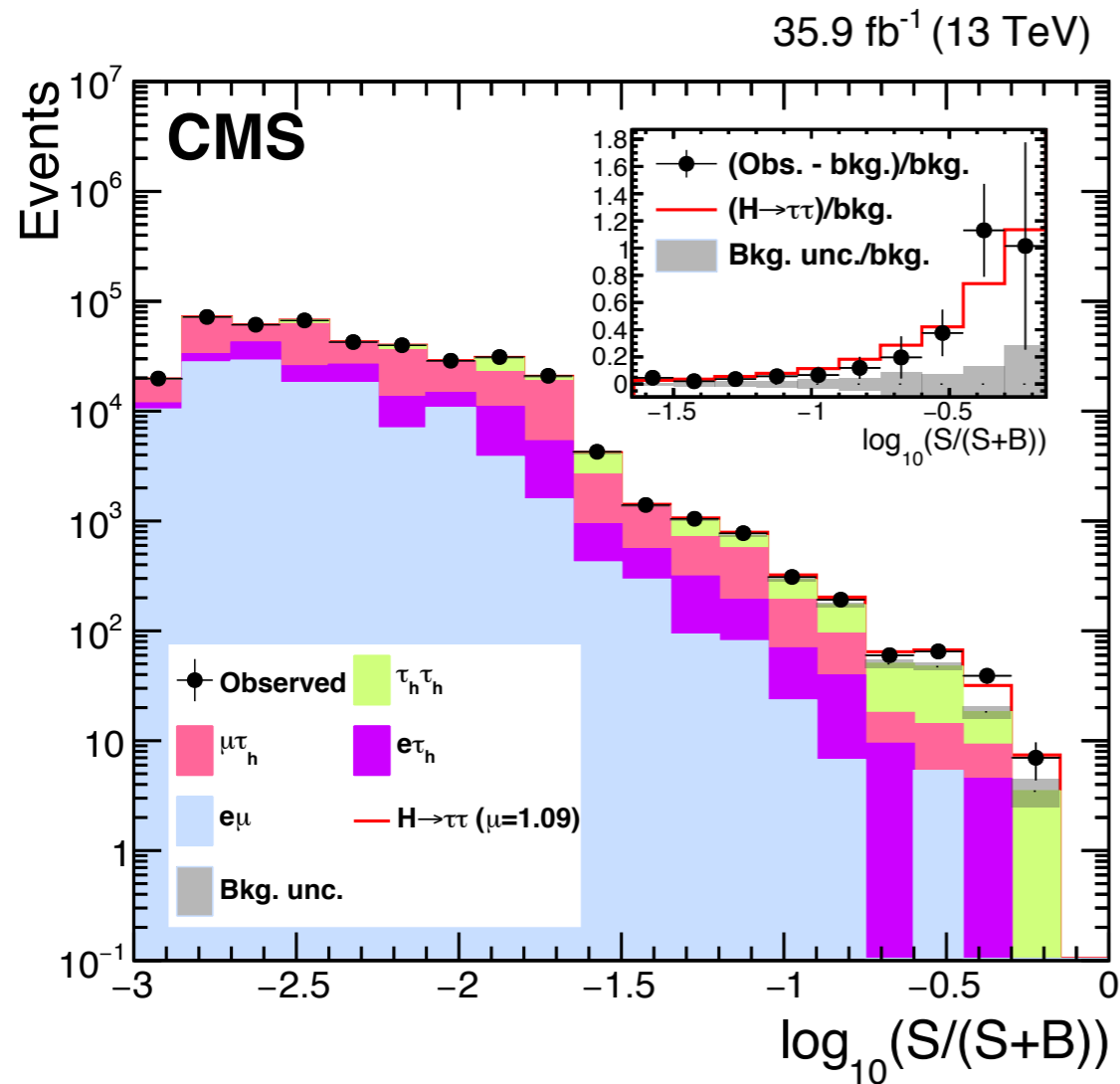

First direct observation  
of Yukawa coupling  
from single experiment!

$$\mu = 1.09^{+0.27}_{-0.26}$$

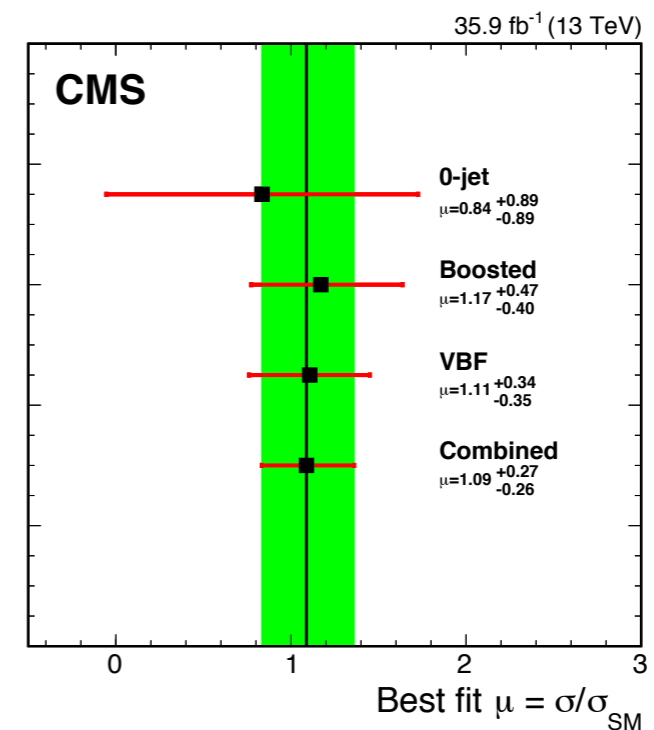
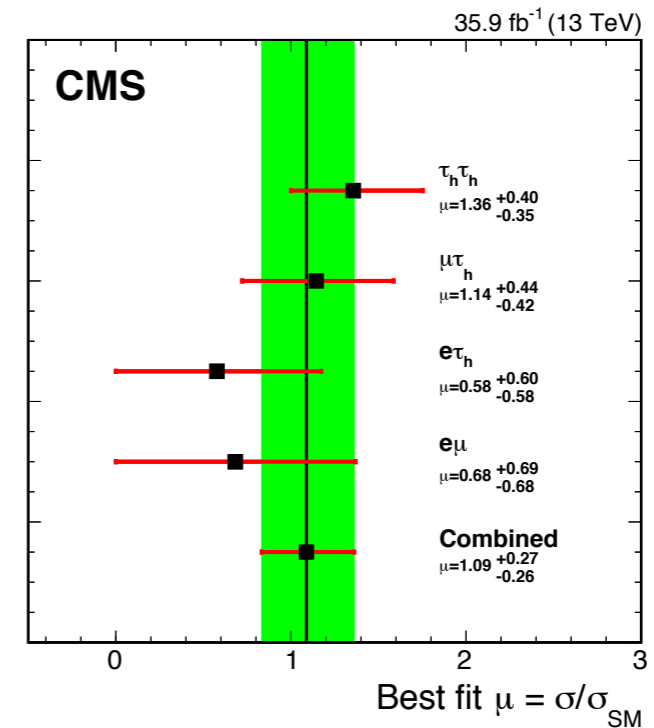

- Very rare decay:  $BR(H \rightarrow \mu\mu)$ :  $\sim 0.022\%$
- Clean experimental signature but large  $Z/\gamma^* \rightarrow \mu\mu$  background.
- Categorize events by BDT score and fit  $M_{\mu\mu}$
- 95% CL upper limit on  $\sigma \times BR$ : 2.64 times SM.
- Observed (expected) significance: 0.98 (1.09)  $\sigma$ .
- Approaching sensitivity to Higgs coupling to **second generation fermions!**

CMS-PAS-HIG-17-019

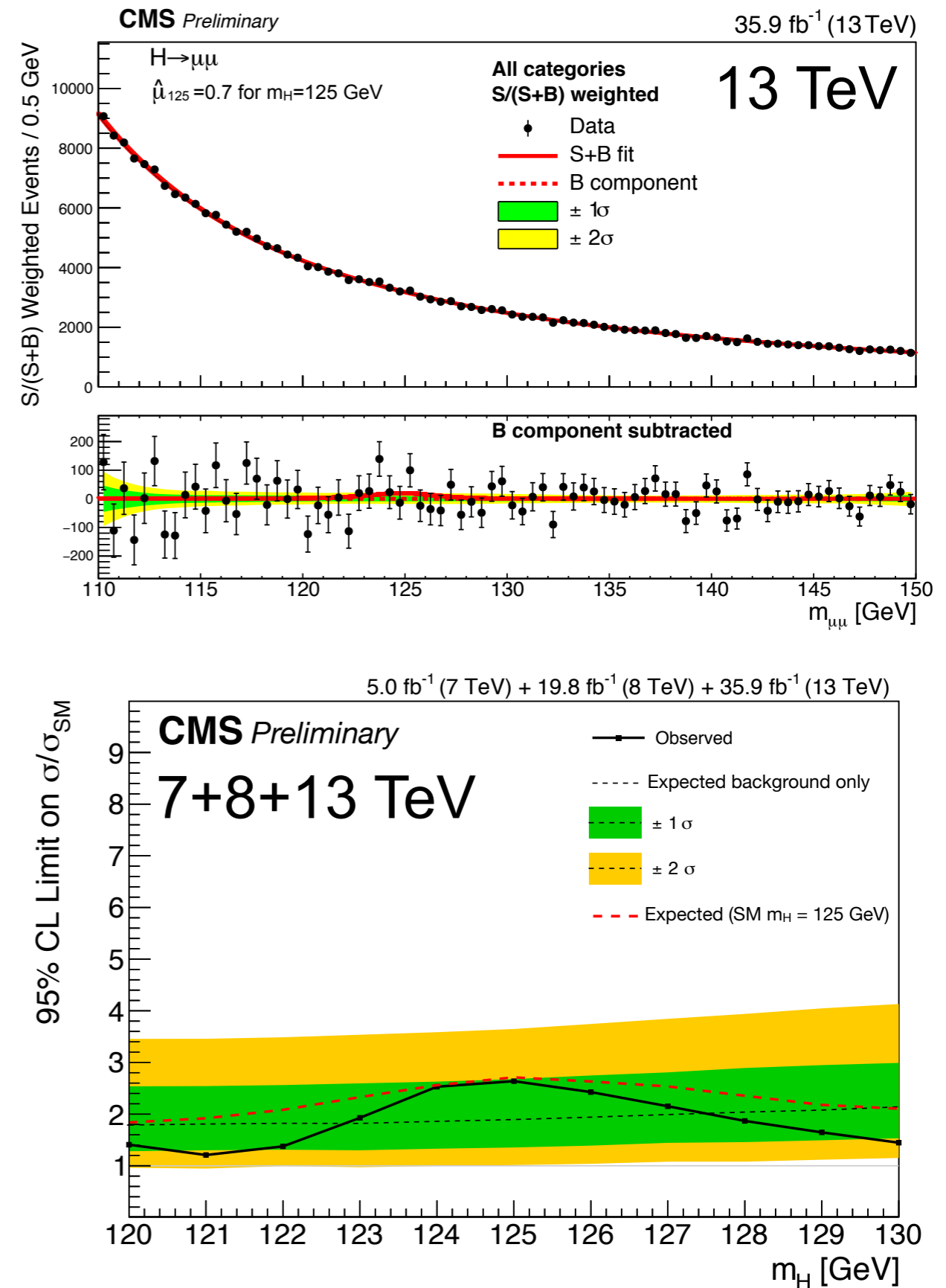

- $t\bar{t}H$  directly probes Higgs coupling to top quark.
- Multi-lepton final states from  $H \rightarrow ZZ/WW/\tau\tau$  decays
- Events categorized by lepton multiplicity as well as lepton flavor/charge and b-tagging.
- Primary backgrounds (separate BDT's trained to discriminate against each):
  - Irreducible:  $t\bar{t}V$ ,  $VV$
  - Reducible: non-prompt leptons and charge mis-ID

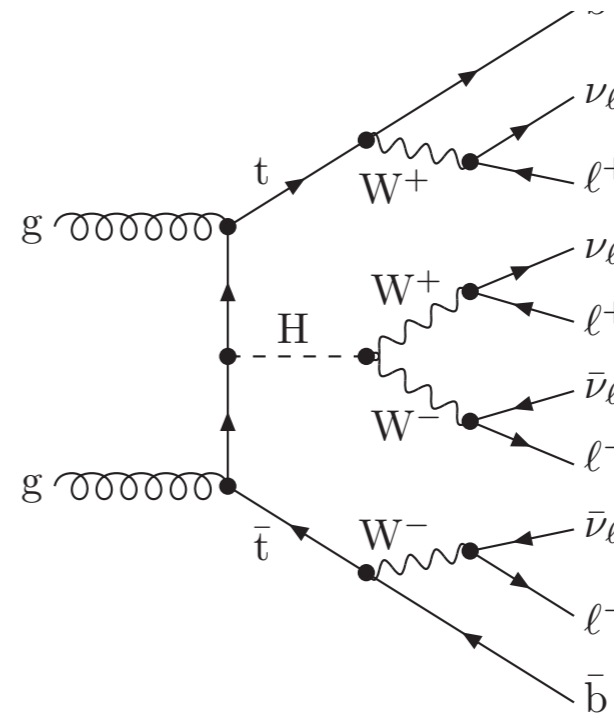
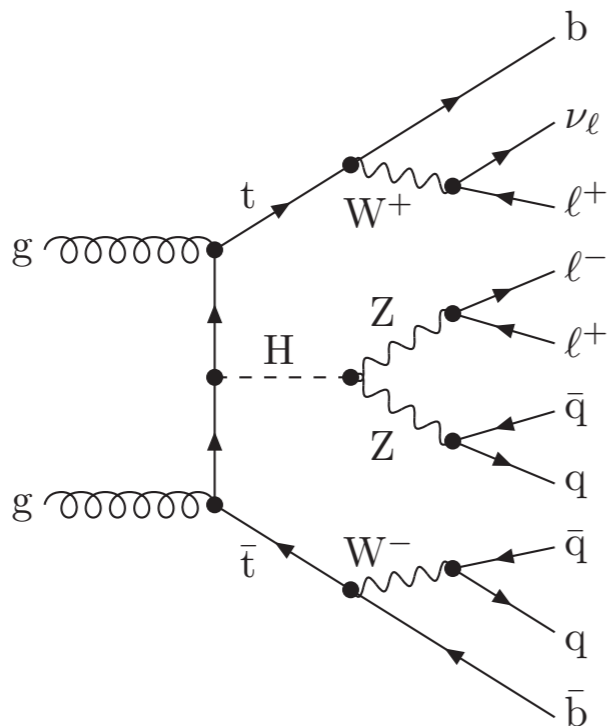
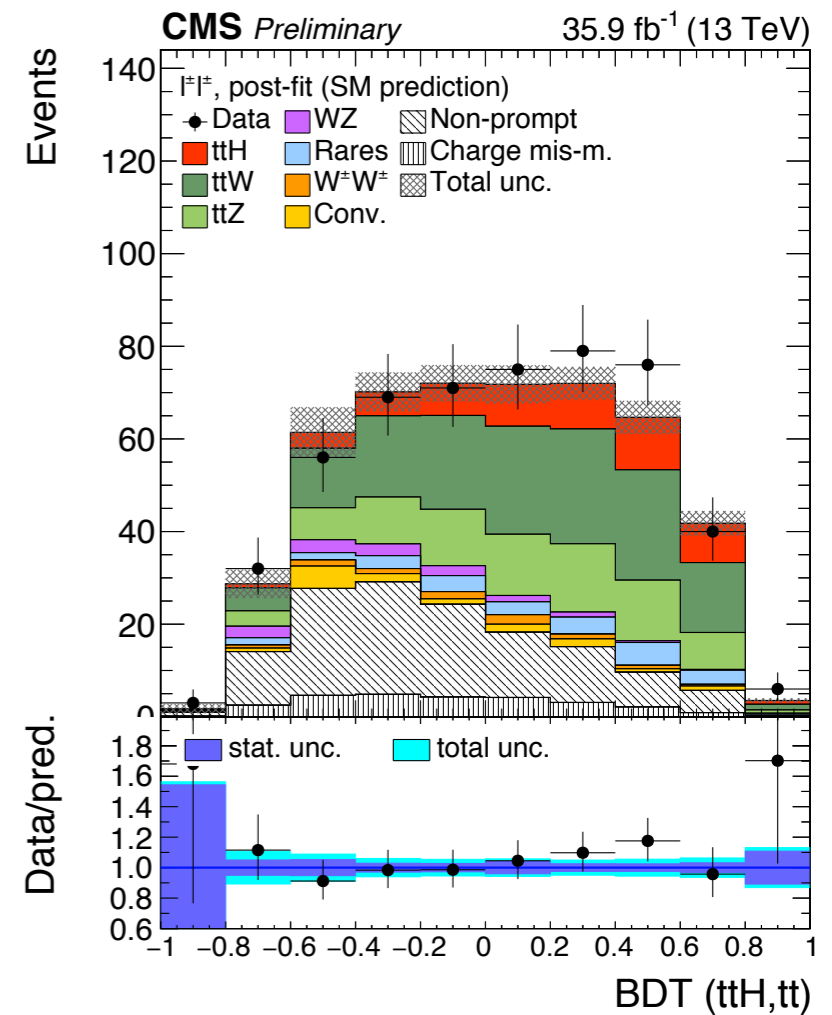

# $t\bar{t}H$ Multi-lepton: Results

- 2D fit based on output of two BDT's
  - BDT<sub>1</sub>:  $t\bar{t}H$  vs.  $t\bar{t}$  and BDT<sub>2</sub>:  $t\bar{t}H$  vs.  $t\bar{t}V$
- 3.3 $\sigma$  observed significance (2.5 $\sigma$  expected)

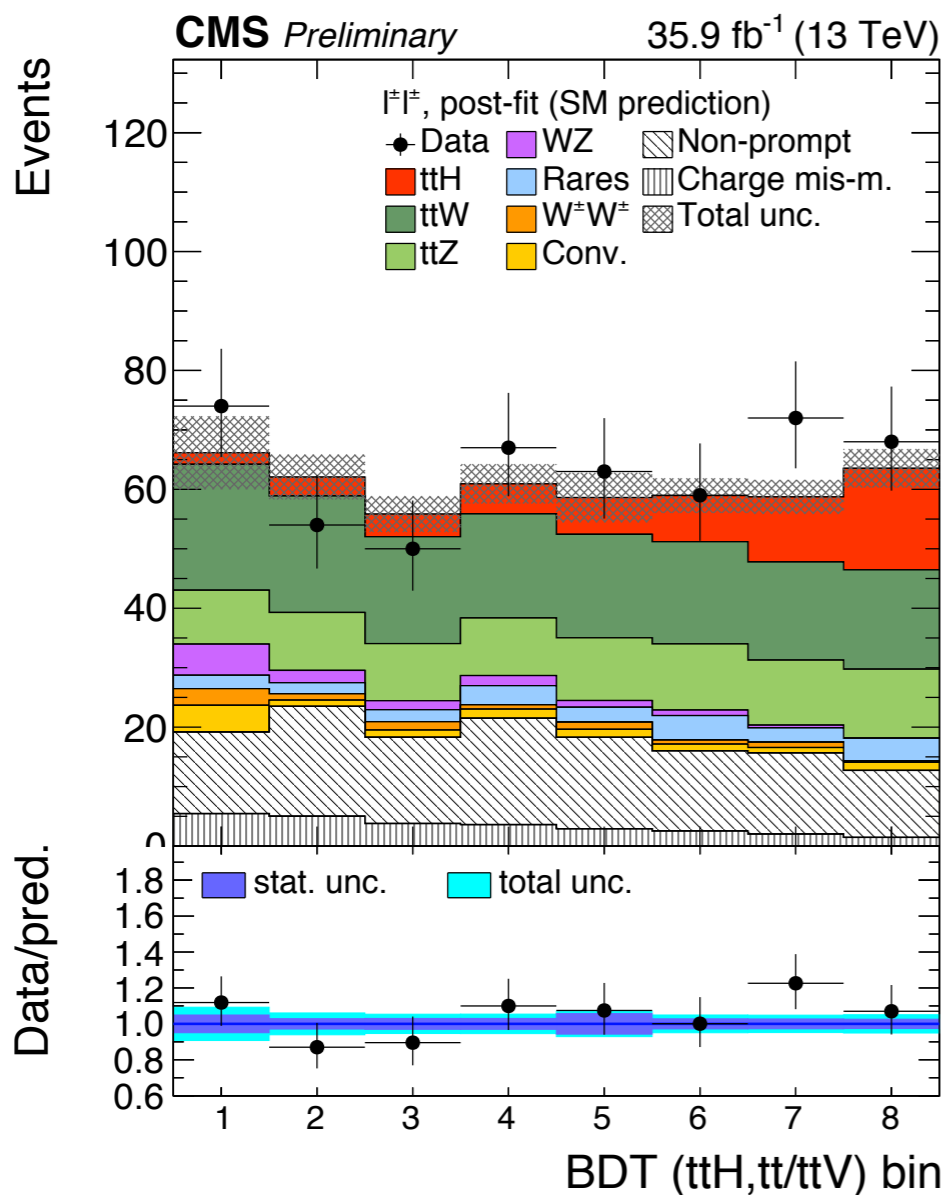

CMS-PAS-HIG-17-003

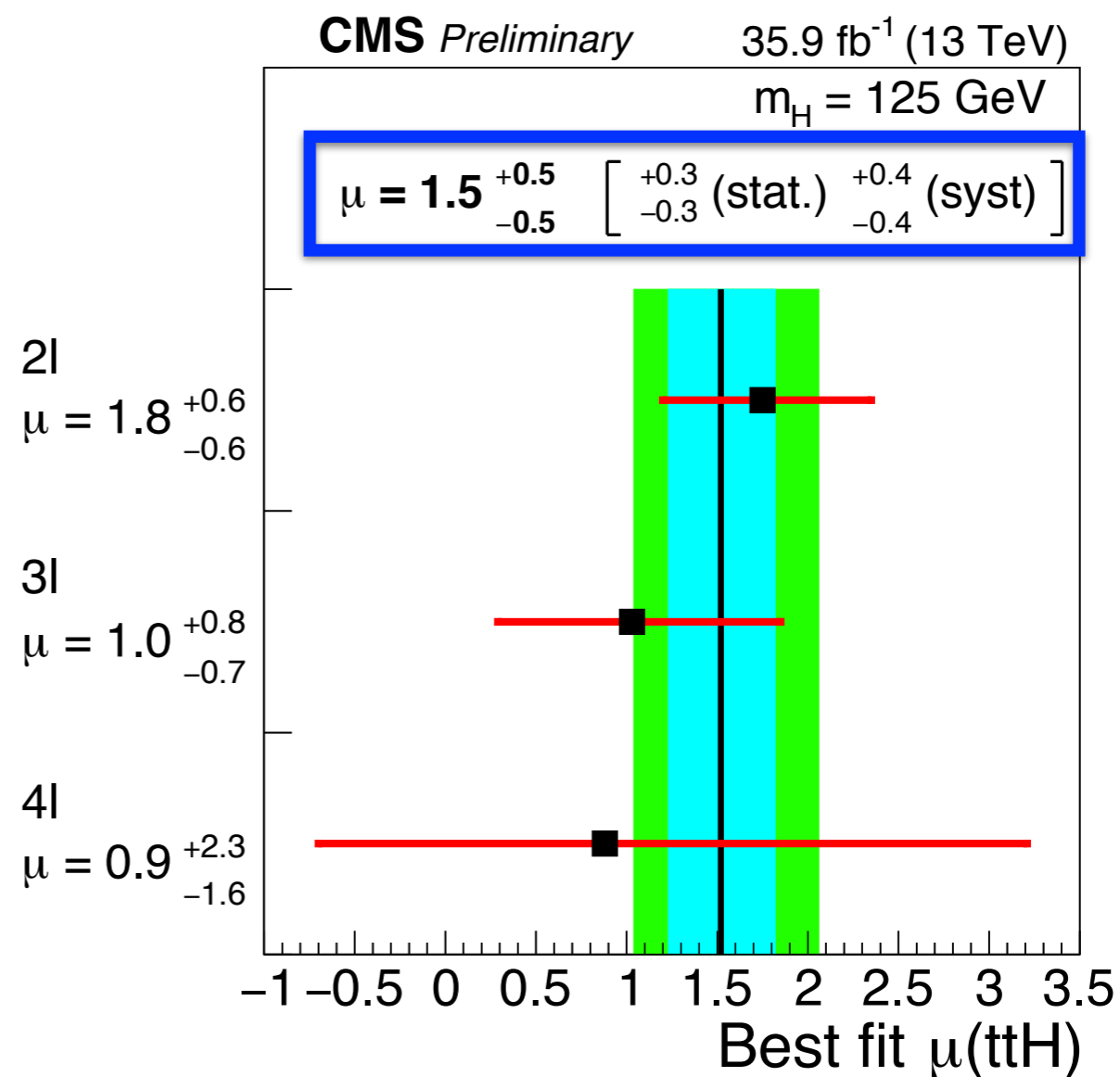

CMS-PAS-HIG-17-004

# $t\bar{t}H, H \rightarrow b\bar{b}$

- Difficult combinatorics and challenging  $t\bar{t}+b\bar{b}$  background.
- Events categorized by jet multiplicity and b-tagging.
- BDT to discriminate signal from background.
- Matrix Element Methods to further discriminate signal from  $t\bar{t}+b\bar{b}$ .

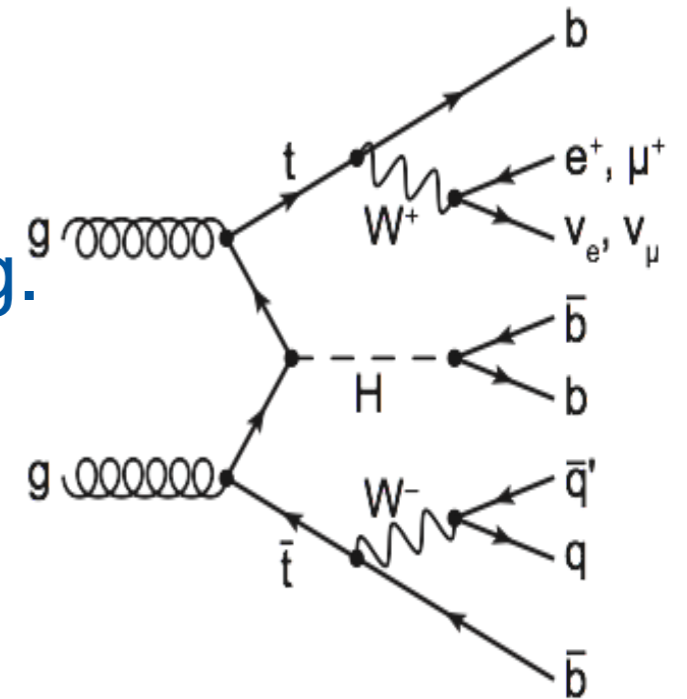

11.4 - 12.9 fb<sup>-1</sup> (13 TeV)

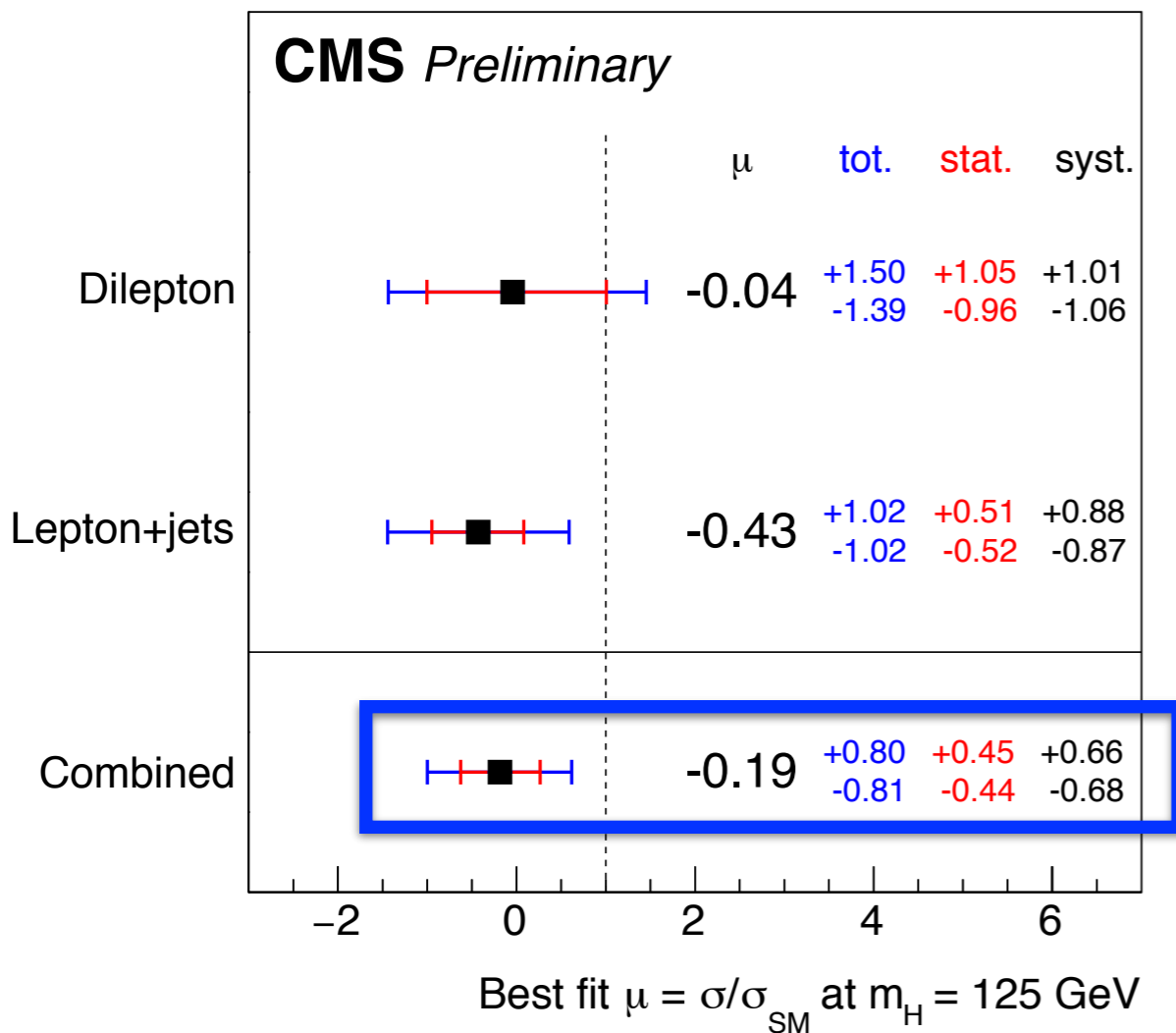

## CMS Simulation

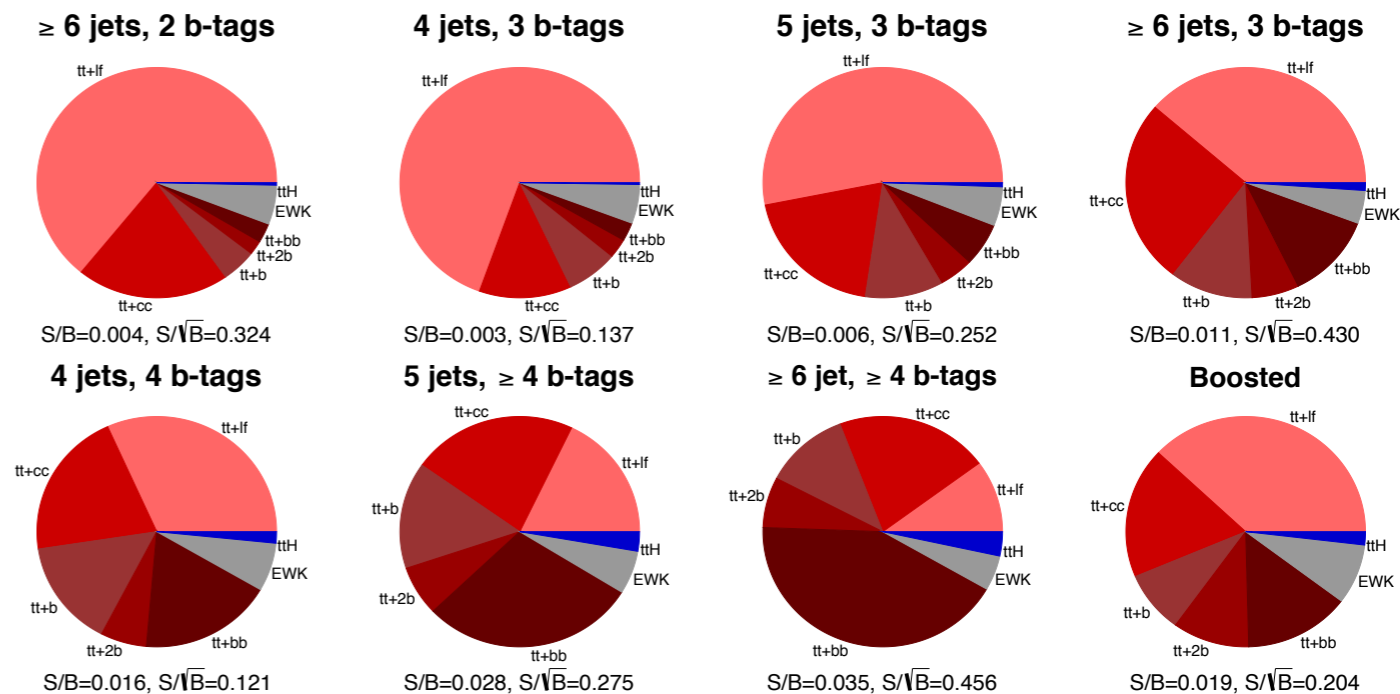

CMS-PAS-HIG-16-038

- With 36/fb of pp collision data at 13 TeV **CMS has already achieved:**
  - First single experiment observation of Higgs **Yukawa coupling to tau leptons**.
  - Evidence for Higgs **Yukawa coupling to bottom quarks** (VH,  $H \rightarrow b\bar{b}$  analysis)
  - Paved the way for the direct observation of **Yukawa coupling to top quark** via ttH production.
  - Beginning to probe Higgs **coupling to second-generation fermions** via  $H \rightarrow \mu\mu$ .
- More than 40/fb of 2017 13 TeV data already on tape with possibly >150/fb for full Run-II
  - **Era of precision measurements in Higgs fermionic sector just around the corner!**

15

# Thank You!



# Additional Material

- [arXiv:1706.04965](https://arxiv.org/abs/1706.04965), accepted by JINST.
- Combine information from sub-detectors into global event description.

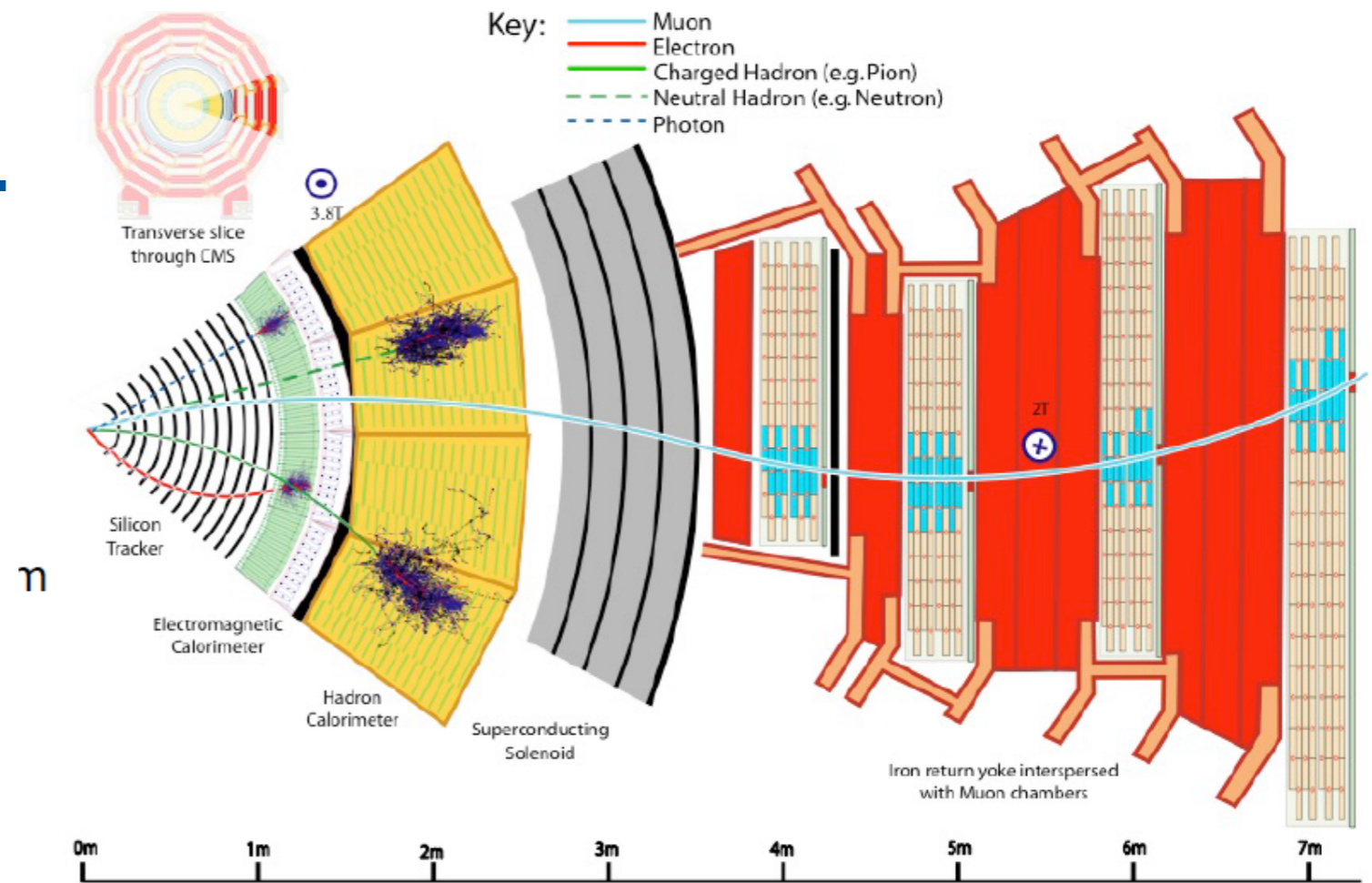

- Reconstruct all particles: electrons, muons, photons, charged/neutral hadrons.

- Run-1 (7+8 TeV):
  - ~ 29 fb<sup>-1</sup> delivered.
- Run-2 (13 TeV):
  - 2015: ~4 fb<sup>-1</sup> delivered.
  - 2016: ~40 fb<sup>-1</sup> delivered.
  - 2017: > 40 fb<sup>-1</sup> delivered!
- Excellent LHC performance comes with challenge of high rates and pile-up.

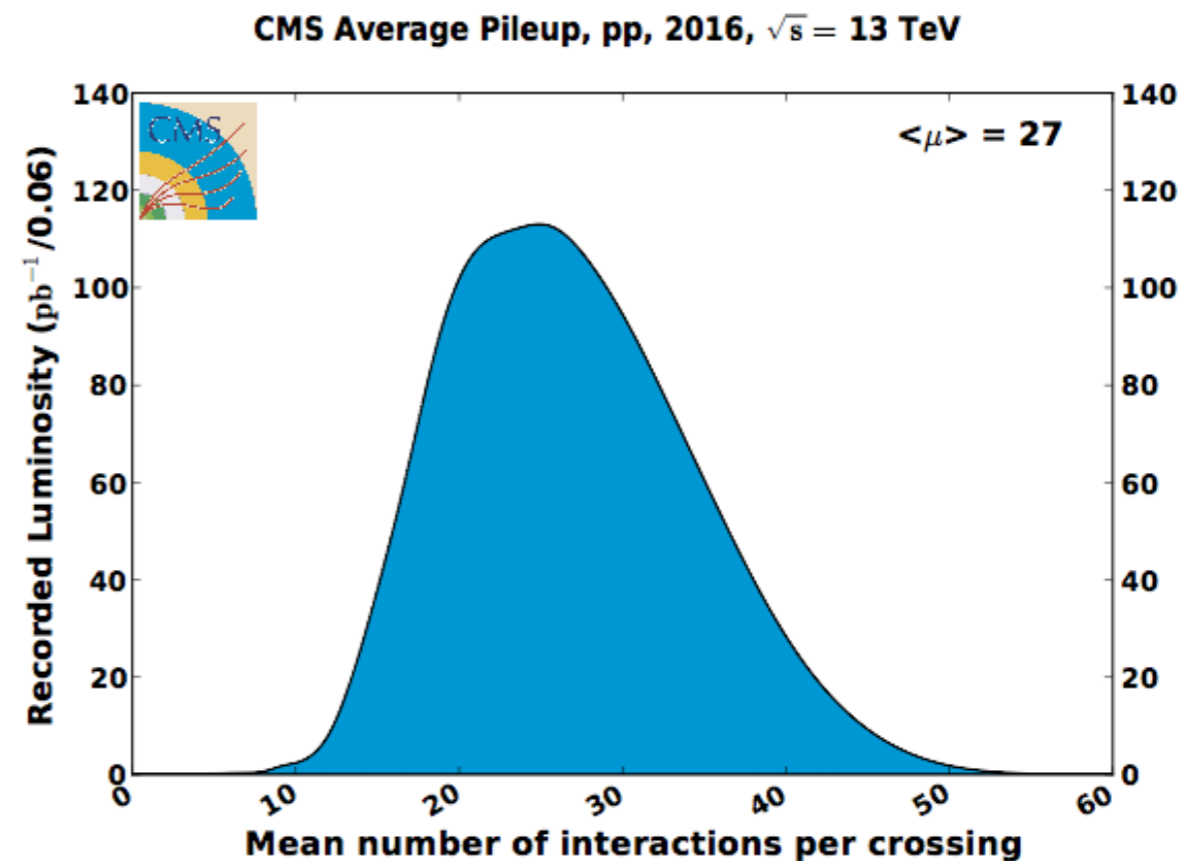
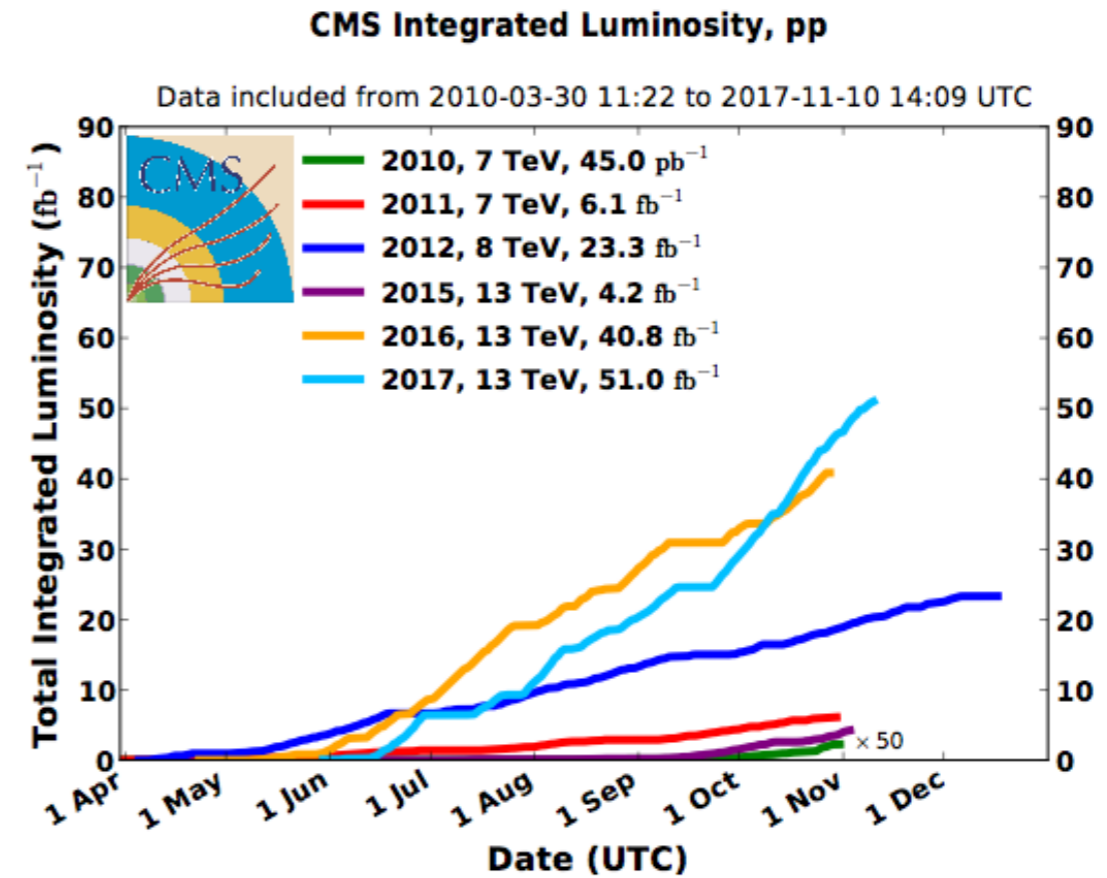

- Interference term between two LO diagrams exposes relative sign of  $\kappa_V$  vs.  $\kappa_t$ .
- Destructive interference in SM:  $\sigma_{SM}(\kappa_V = \kappa_t = 1) = 70.96$  fb.
- For inverted top coupling cross section increased by order of magnitude.
- Two dedicated CMS analyses:
  - multi-lepton: [CMS-PAS-HIG-17-005](#)
  - $b\bar{b}$ : [CMS-PAS-HIG-16-019](#)

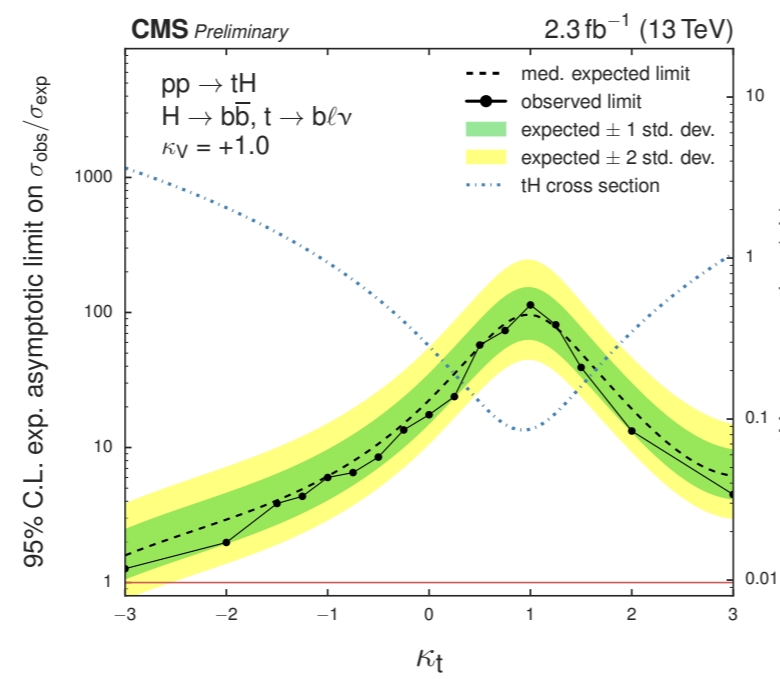
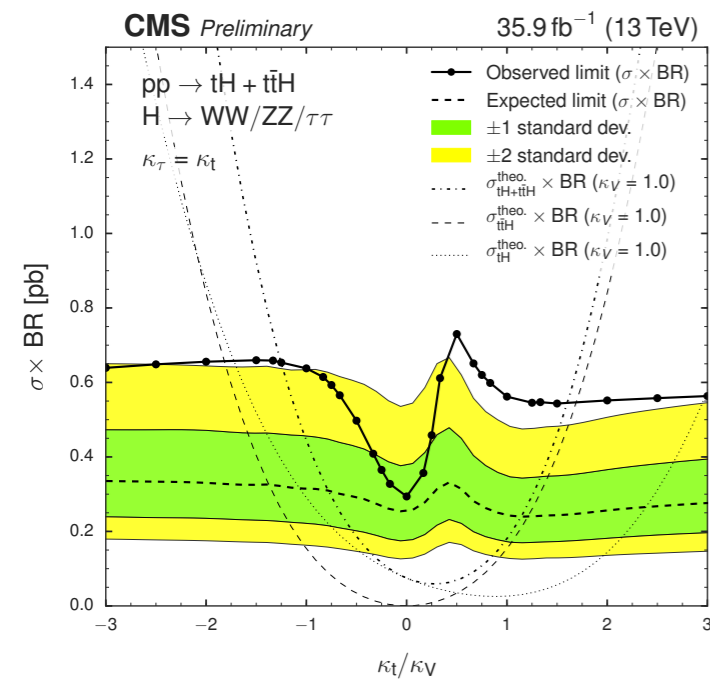
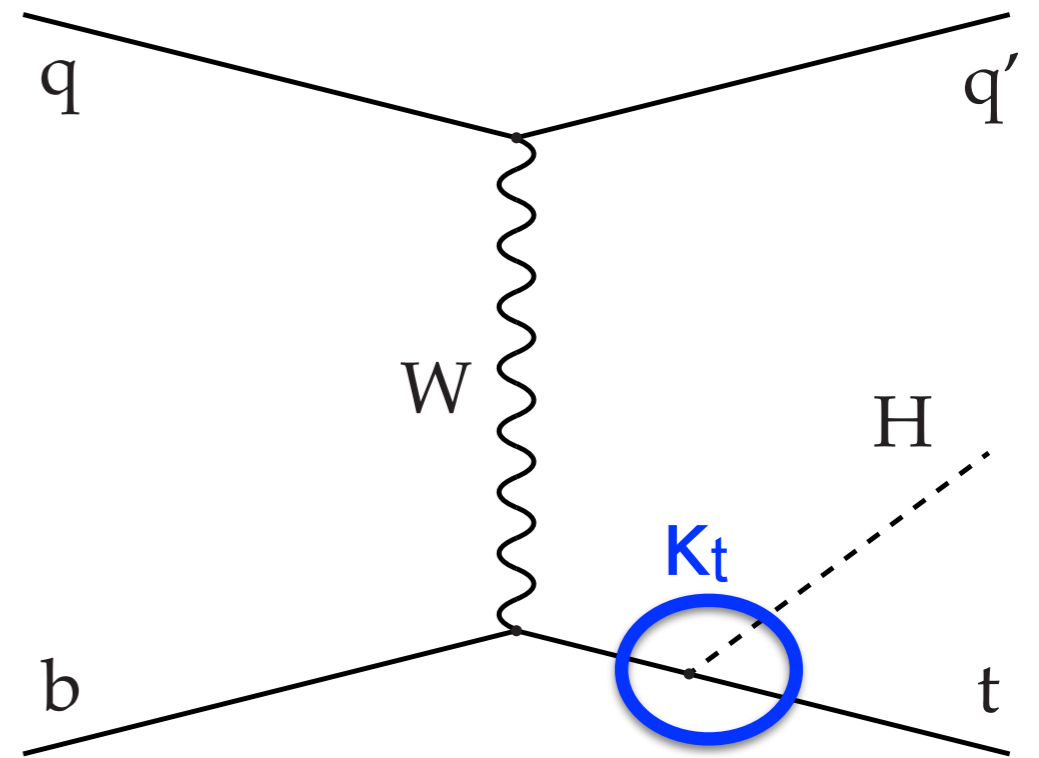
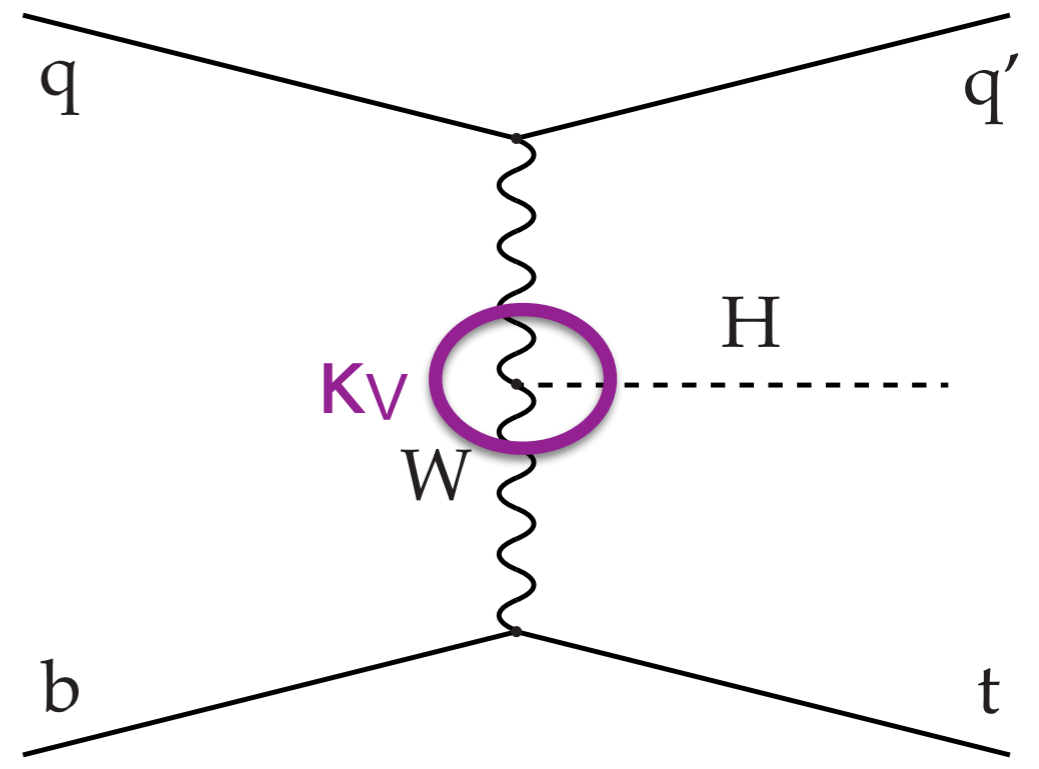

- All-jet final state dominated by QCD multi-jet background.
- Data-driven fits to  $M(b\bar{b})$  on events categorized by MVA discriminant.

## 13 TeV (2015 preliminary)

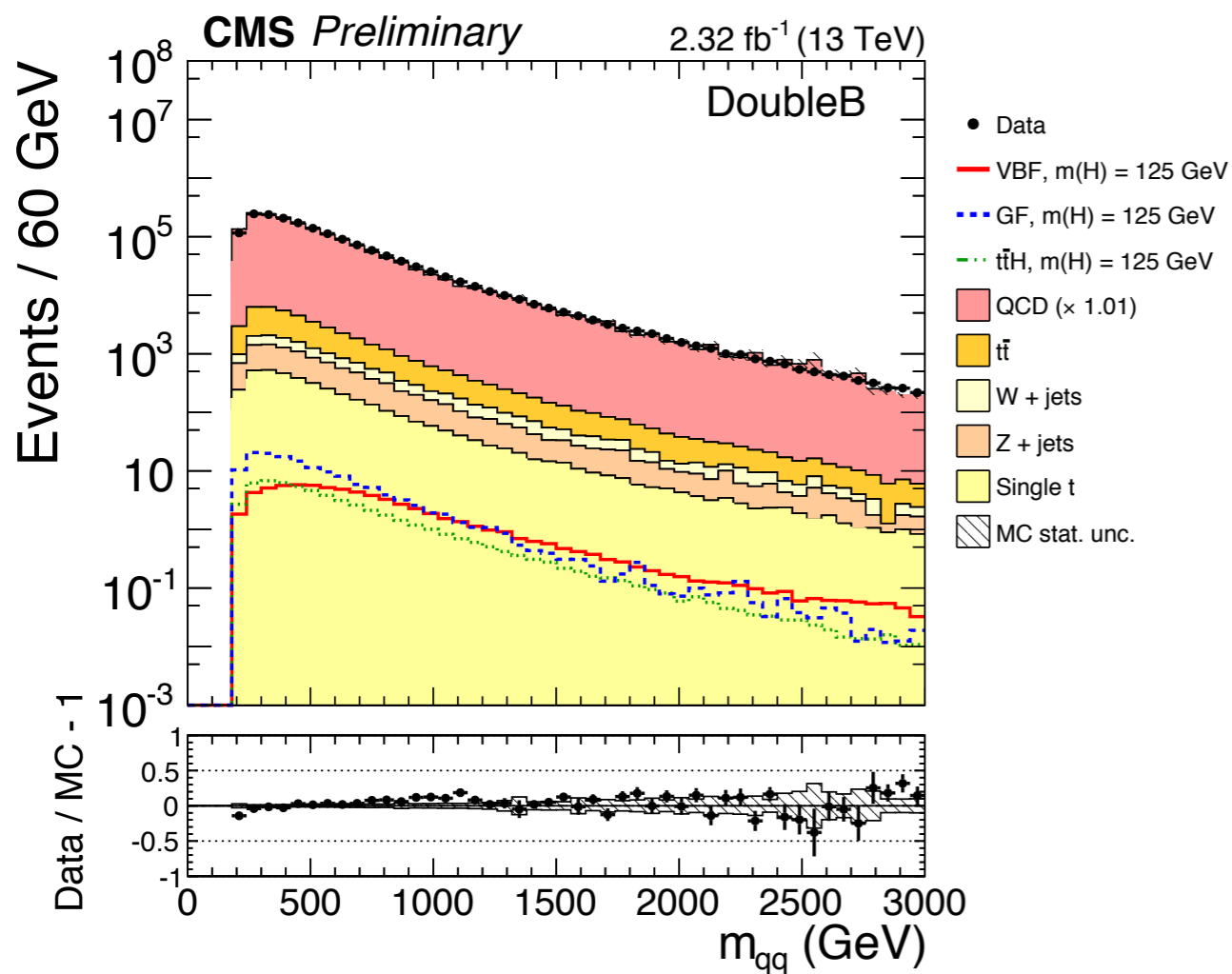

**CMS-PAS-HIG-16-003**

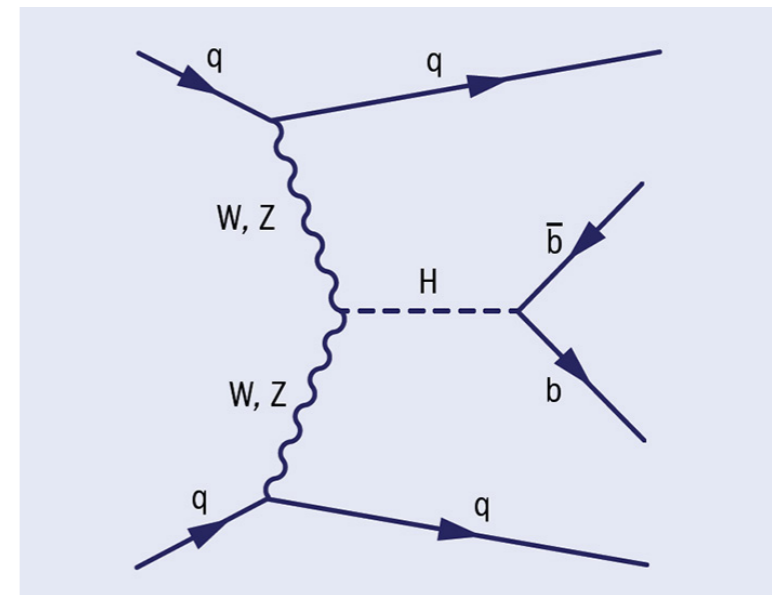

## 8 TeV ( $3.6\sigma$ $Z \rightarrow b\bar{b}$ )

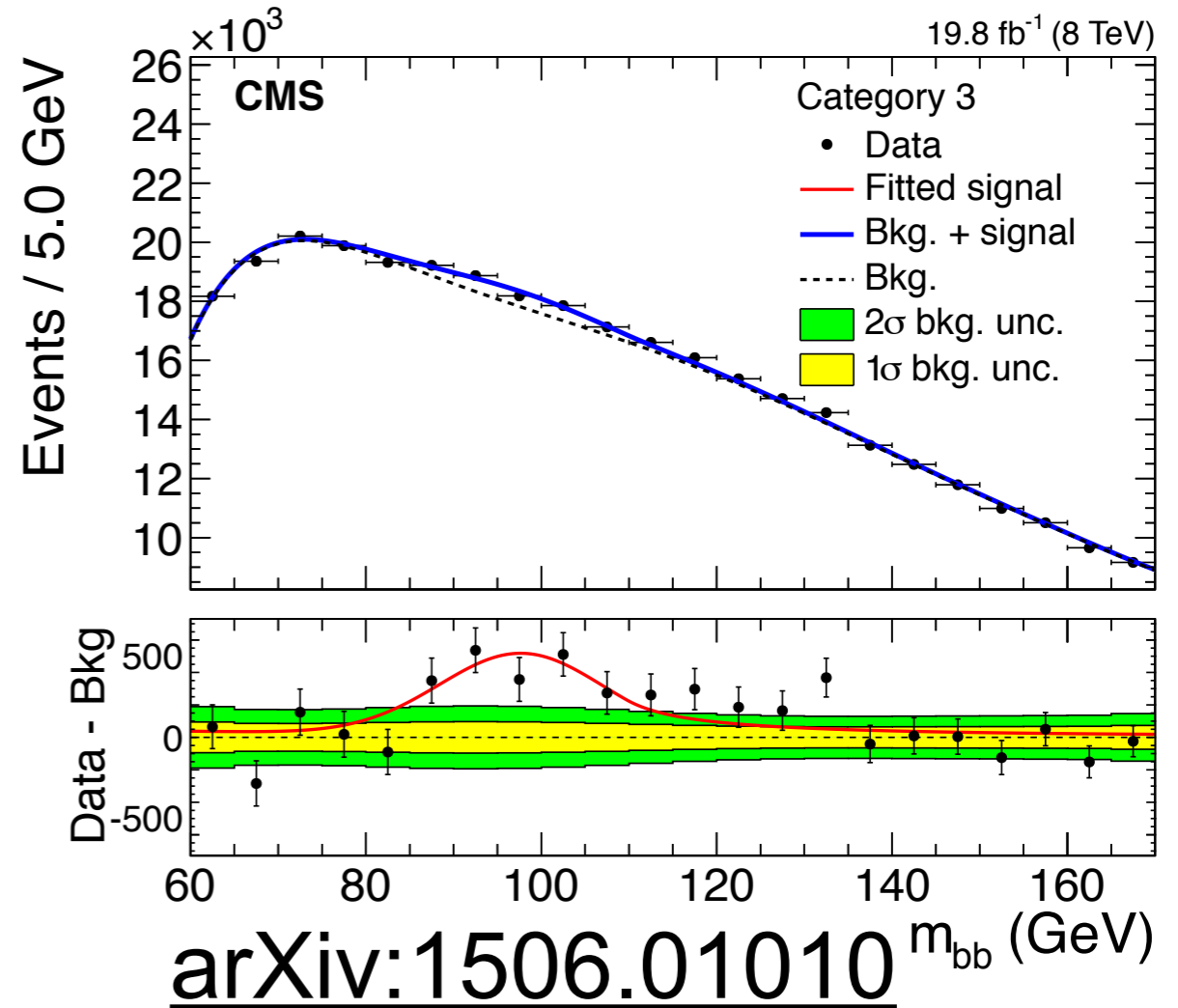

**arXiv:1506.01010**

# VZ(b $\bar{b}$ ) Cross-check Analysis

- Standard candle right next to Higgs peak.
- **BDT's re-trained** to extract VZ(b $\bar{b}$ ) signal, including SM VH(b $\bar{b}$ ) as background.
- **Mass window shifted** to accommodate Z(b $\bar{b}$ ) peak.
- Same: BDT inputs, control regions, jet energy regression, analysis methodology.

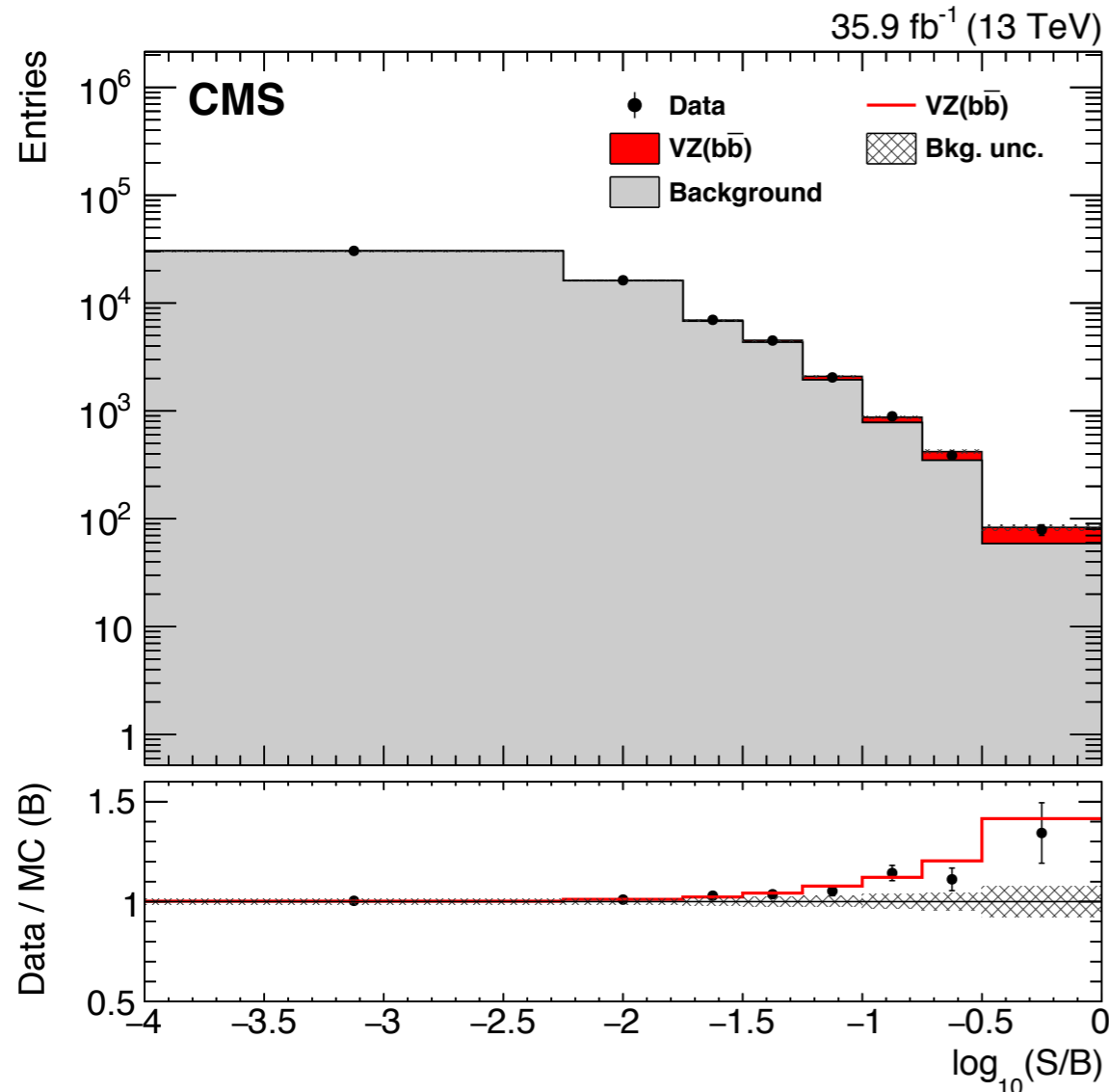

significance  
**4.9 $\sigma$  expected**  
**5.0 $\sigma$  observed**

Channels	Significance expected	Significance observed	Signal strength observed
0-lepton	3.1	2.0	0.57 ± 0.32
1-lepton	2.6	3.7	1.67 ± 0.47
2-lepton	3.2	4.5	1.33 ± 0.34
Combined	4.9	5.0	1.02 ± 0.22