

Nuclear physics detection solution, from double beta decay to forest fires

Fabrice Retiere (TRIUMF)

Work done within the PHoton for Astro-particle and Applied Research
(PHORWARD) group at TRIUMF

Collaboration with U.Sherbrooke (QC, Canada) for the Photon to Digital
Converter

Support from TRIUMF Sci Tech dept and NSERC MRS



Outline

- Searching for neutrinoless double beta decay in nEXO
 - By detecting scintillation light
 - A journey towards the optimum single photon detector
- Measuring the energy of neutrons produced in fusion reaction
 - By detecting scintillation light
 - In partnership with General Fusion (Richmond, BC)
 - Optimizing the optimum single photon detector
- Detecting forest fire before they become catastrophic
 - Ultra low power, high performance smoke detection
 - Optimizing a system relying on the optimum single photon detector

nEXO for $0\nu\beta\beta$

[Double beta decay]

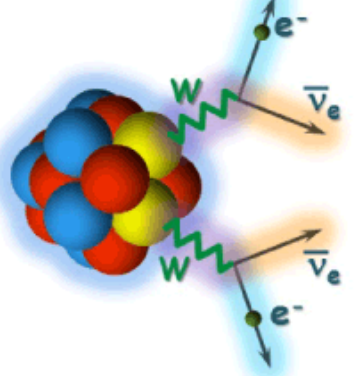

Double beta decay which emits anti-neutrinos

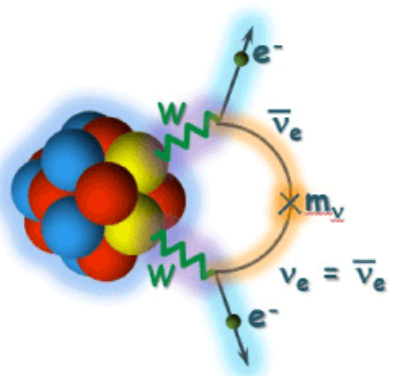

Neutrinoless double beta decay

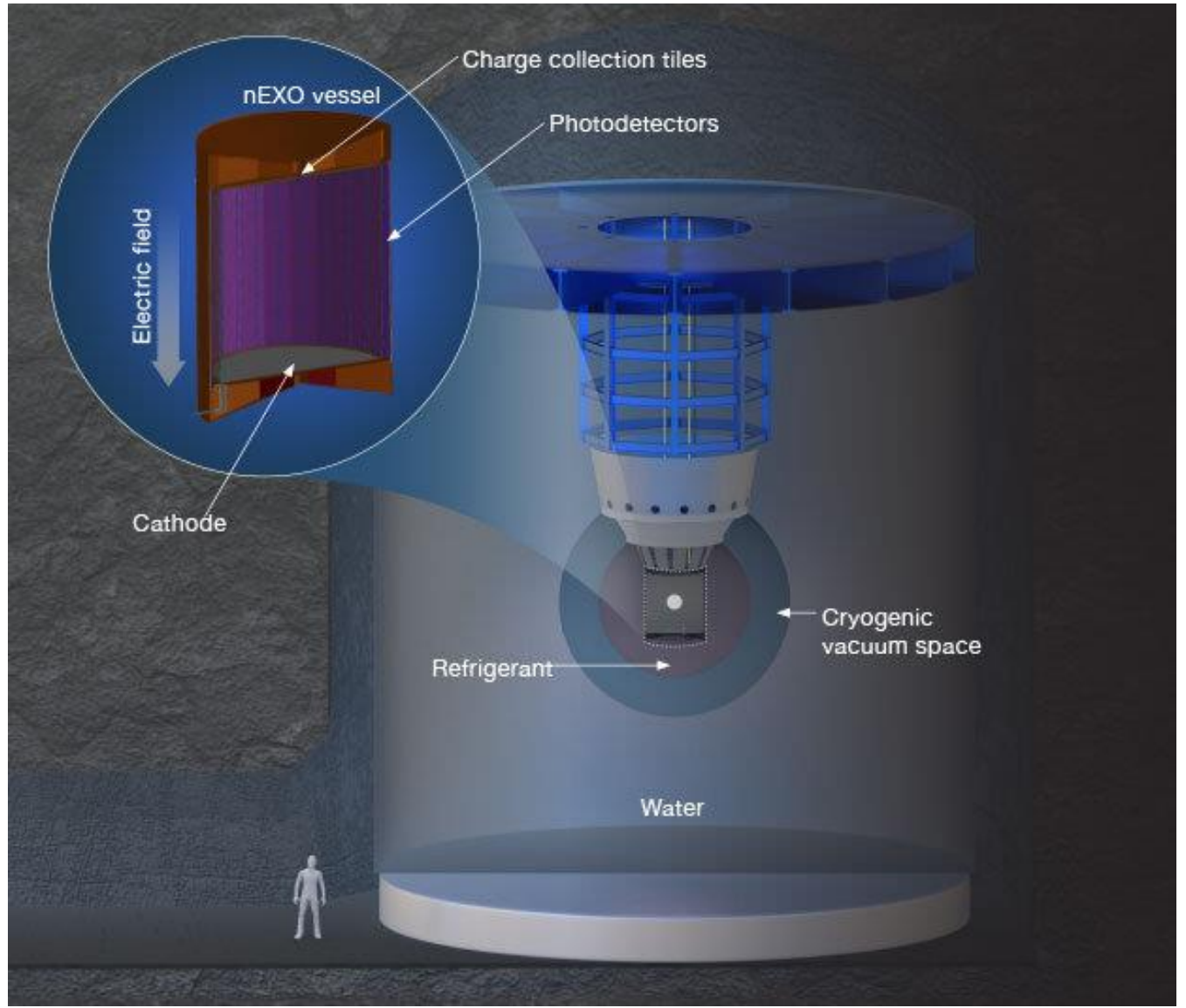
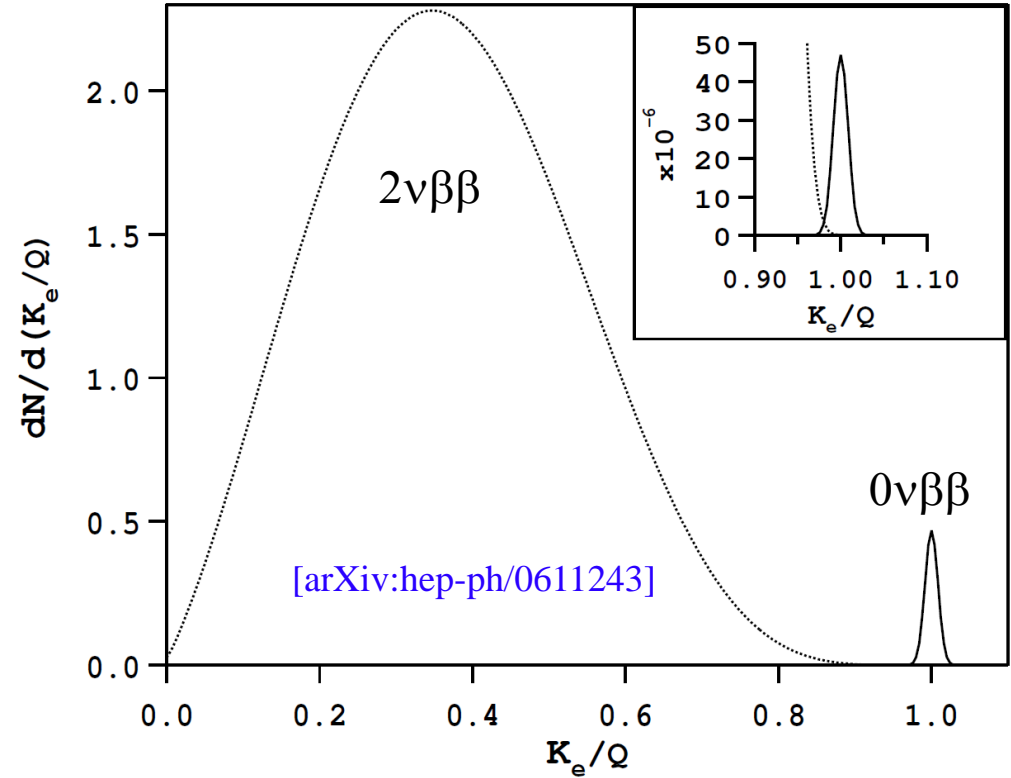

See talk by Thomas Brunner on Tuesday afternoon

Liquid Xenon time project chamber

- Searching for ^{136}Xe decay at 2.456 MeV
- Collect charge produced in liquid Xenon with an electric field
 - Information about position and energy
- Detect scintillation photons
 - All light emitted within 100ns \rightarrow time of the event
 - Also information about energy

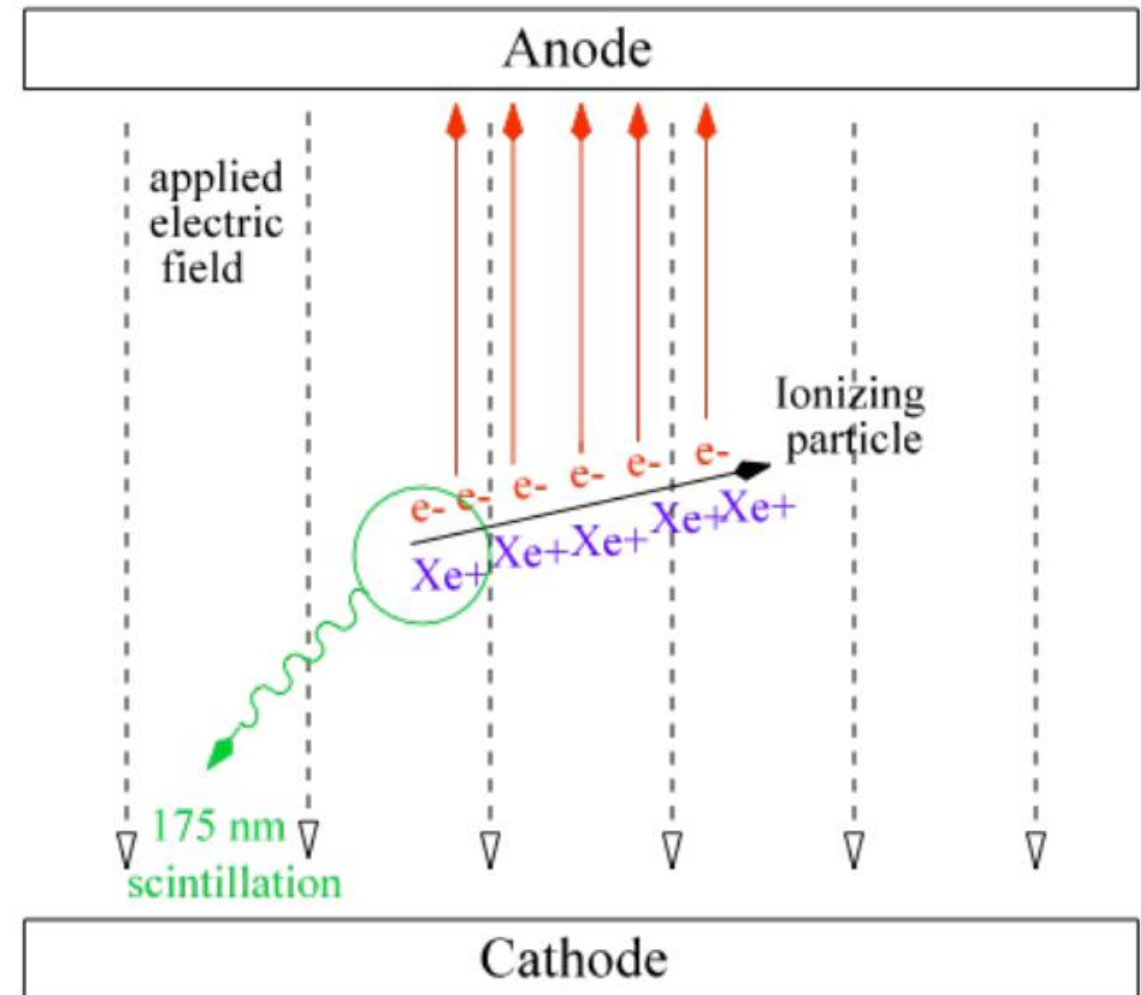

Liquid Xenon scintillation at $\sim 175\text{nm}$

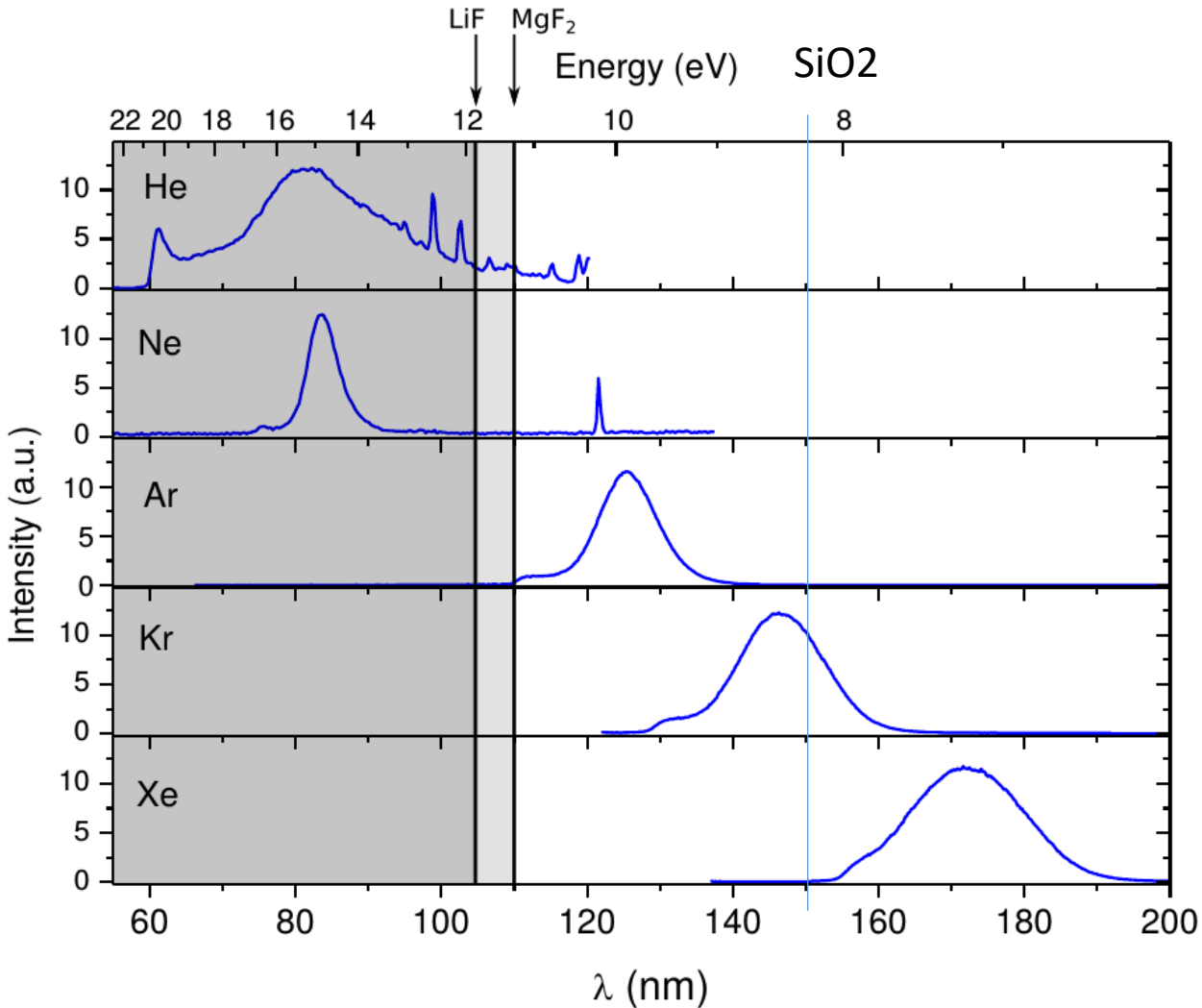

- Easiest Noble-gas liquid scintillation to detect
- Above SiO₂ cut-off
 - Can still use standard silicon technology
- Bright and short flash
 - Number of photons produced $\sim 125,000$ at 2.5 MeV
 - All photons emitted within 150ns

Detecting scintillation light in nEXO

- Use $1 \times 1 \text{ cm}^2$ silicon photomultipliers
- 24 staves - 130 cm long
- 12 tiles per staves

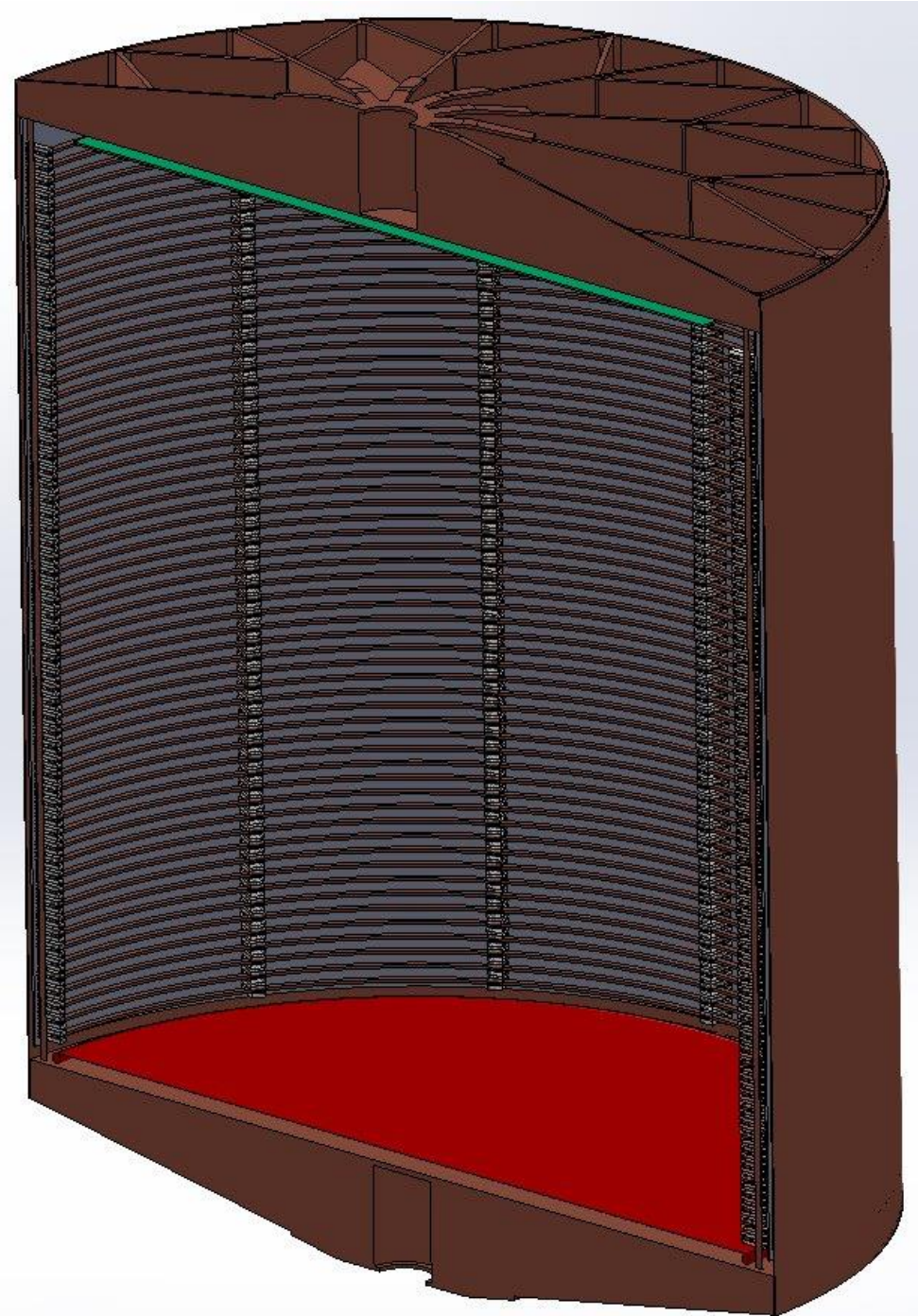
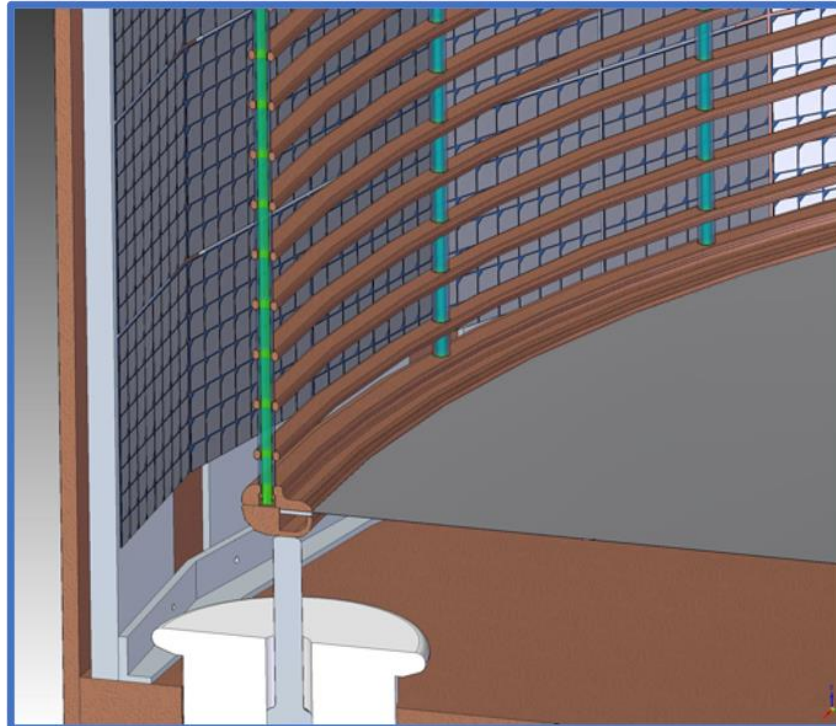

A silicon photo-multiplier – many diodes in parallel isolated by a resistor

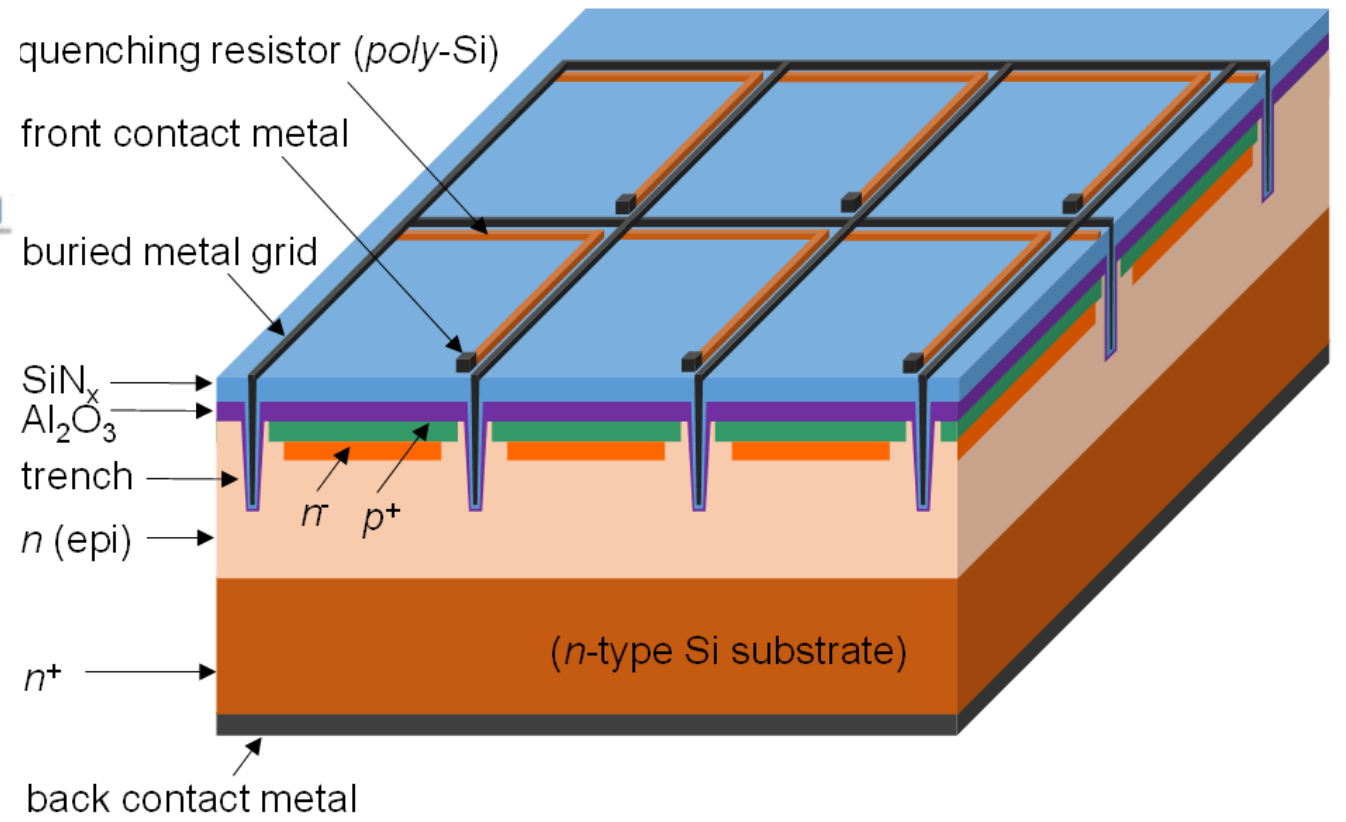
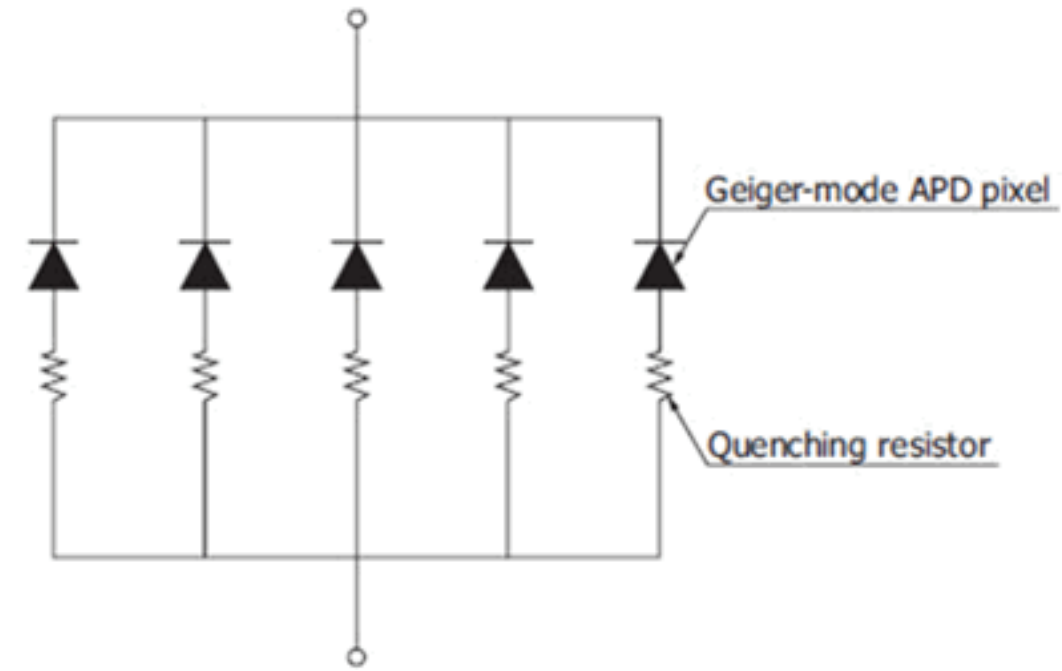

<https://sites.gatech.edu/lanns/research/silicon-photomultipliers/>

SiPM, Silicon photomultiplier

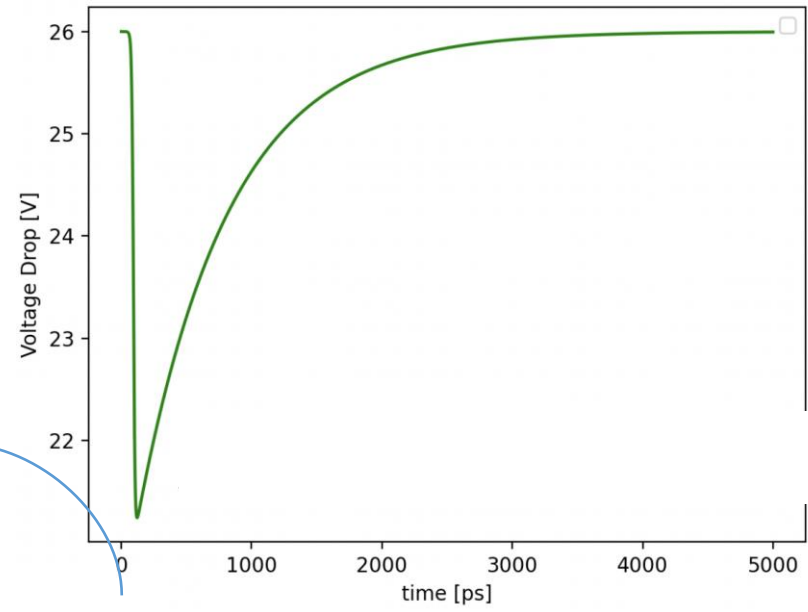
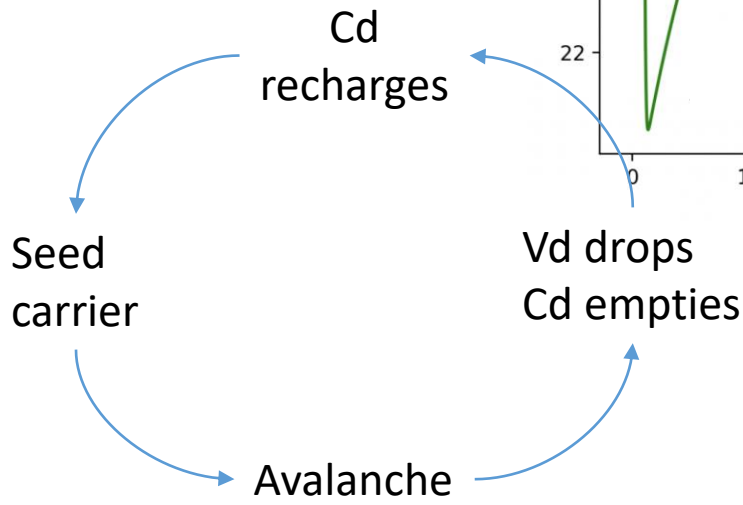
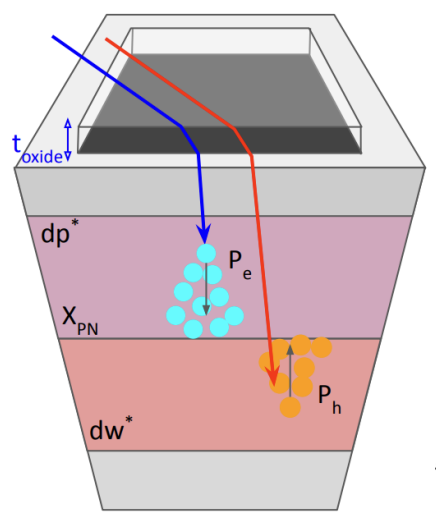

An array of Single Photon Avalanche Diodes (SPAD)

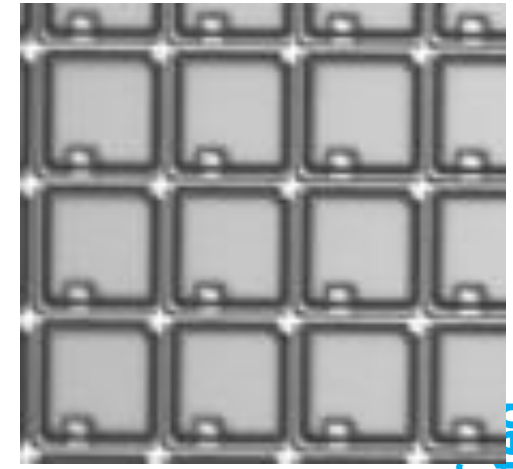
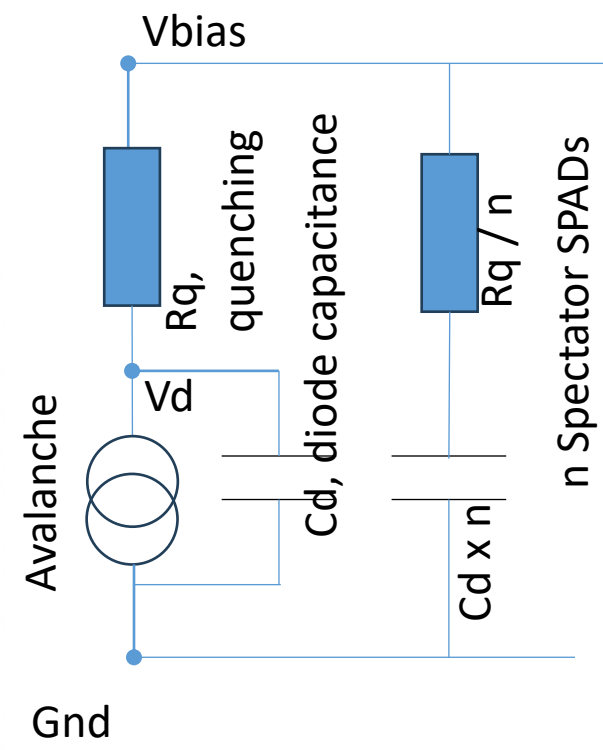
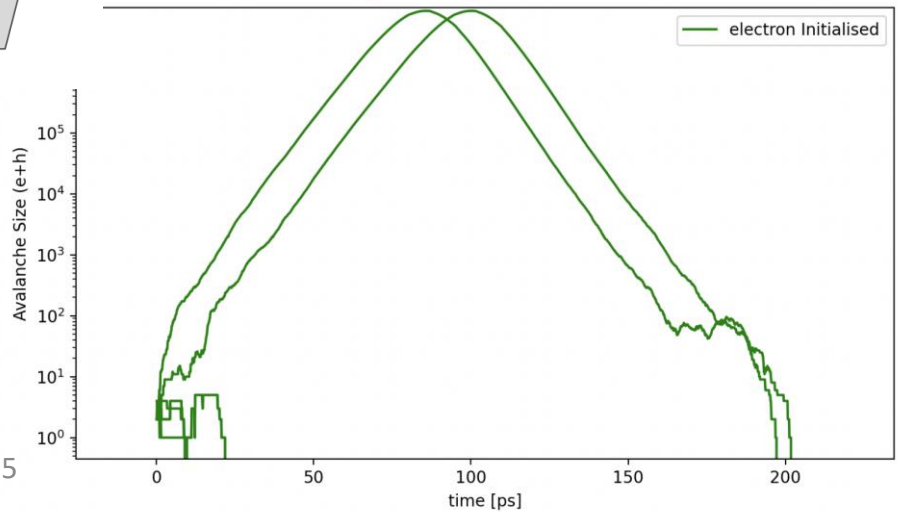

Using Silicon device because of their very low radioactivity

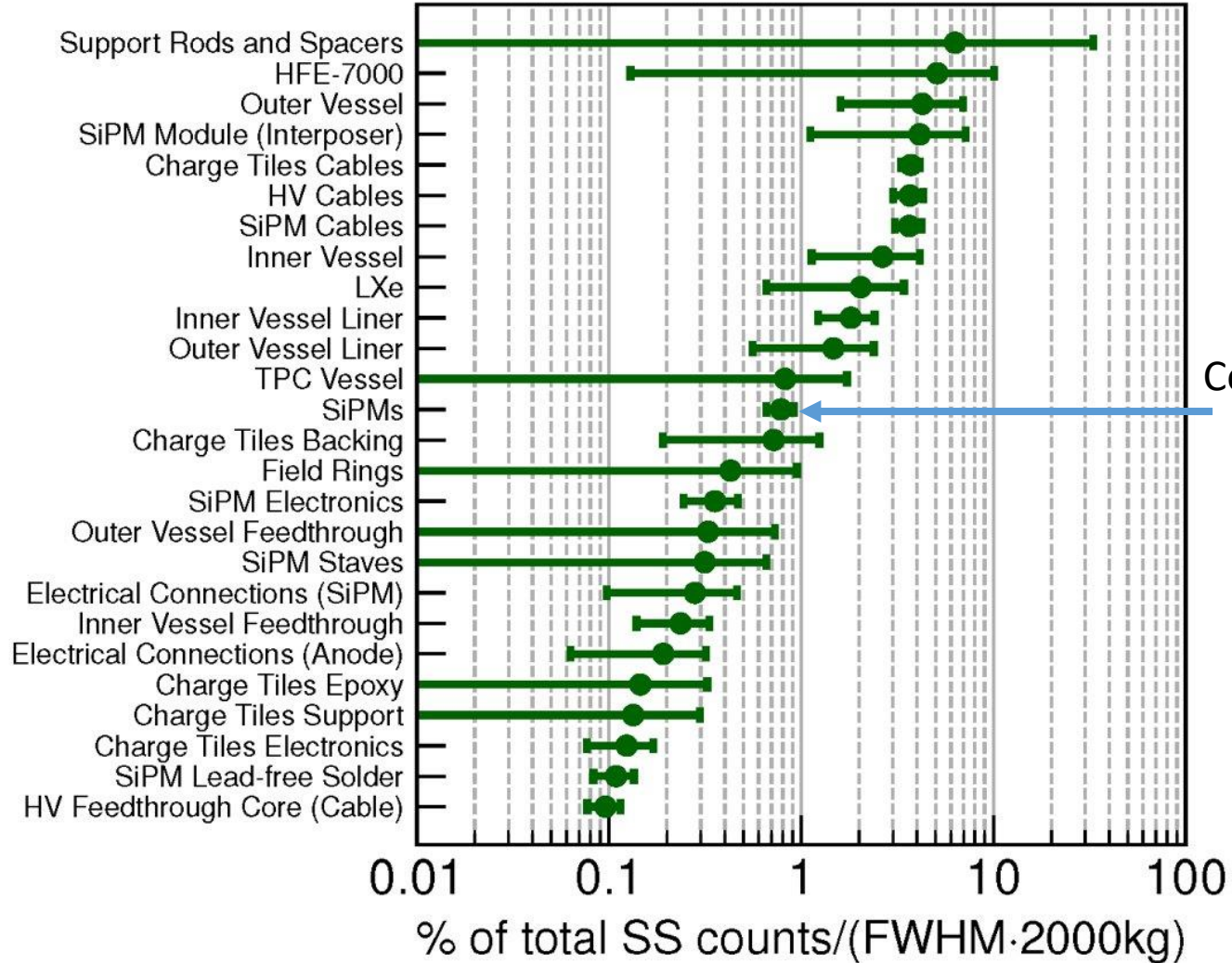

- Several orders of magnitude lower radioactivity than PMT

Contribute less than 1% of background

Performances in one slide – almost 10 years of work!

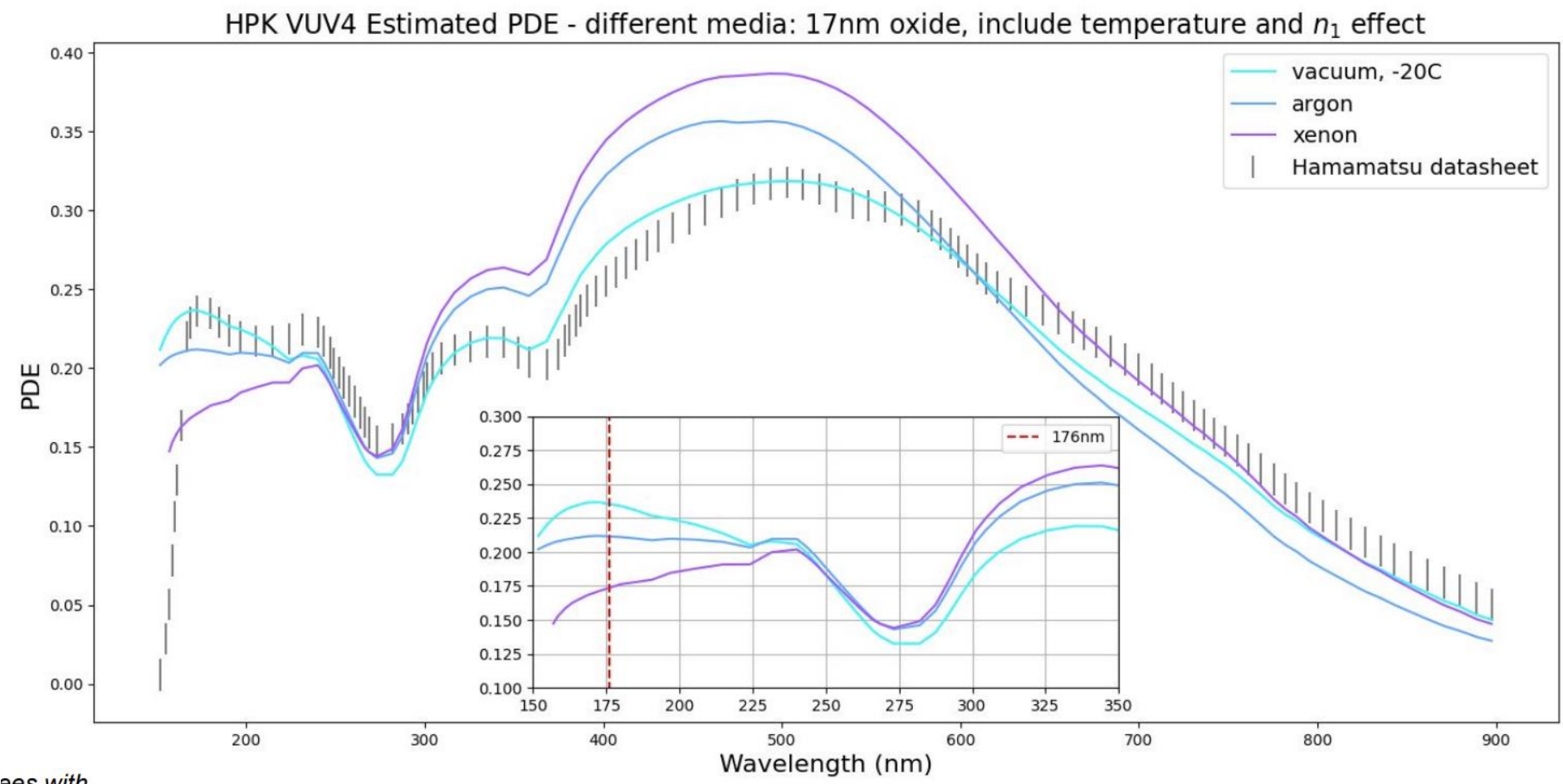

ees with

nEXO tiles – 12x8 1cm² Hamamatsu MPPC

Quartz – low radioactivity solution

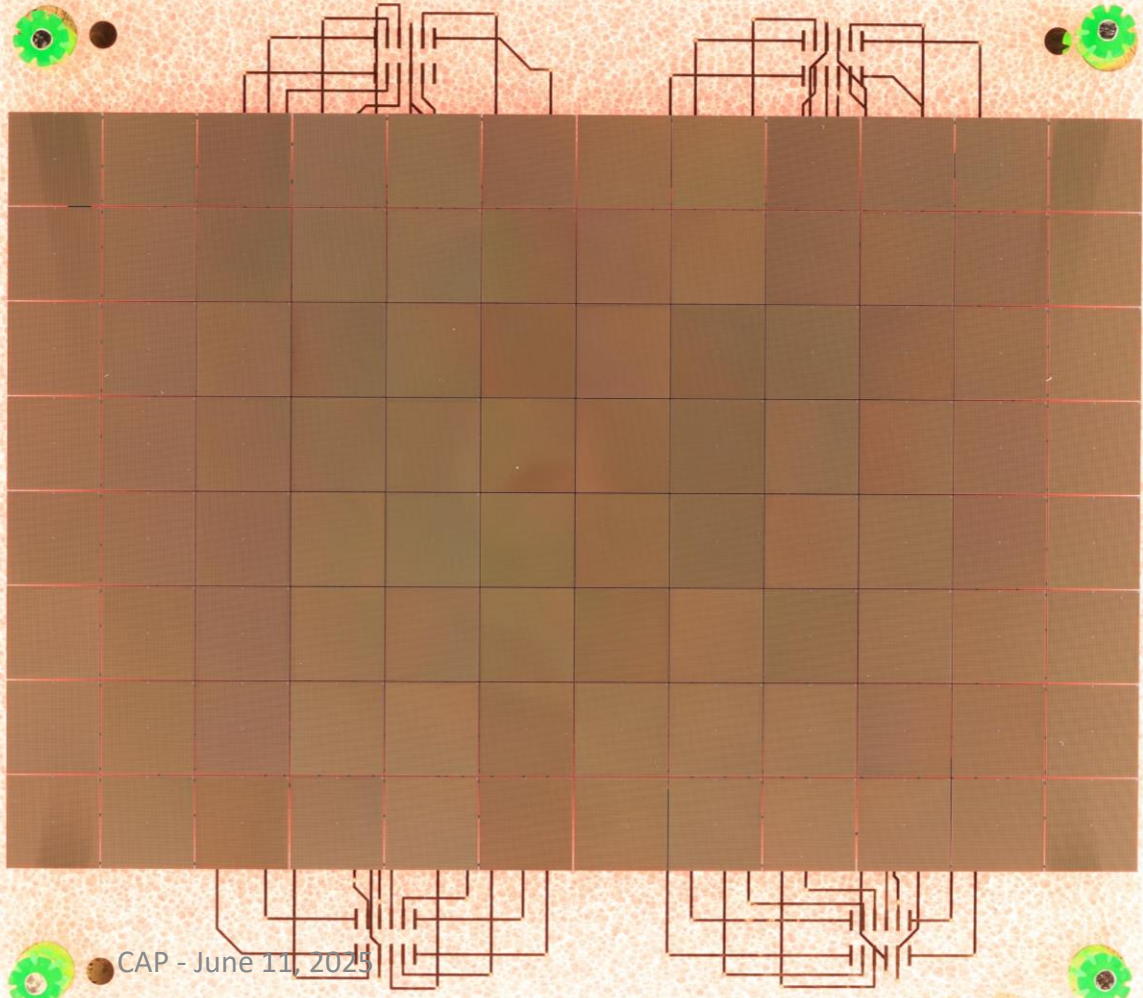

CAP - June 11, 2025

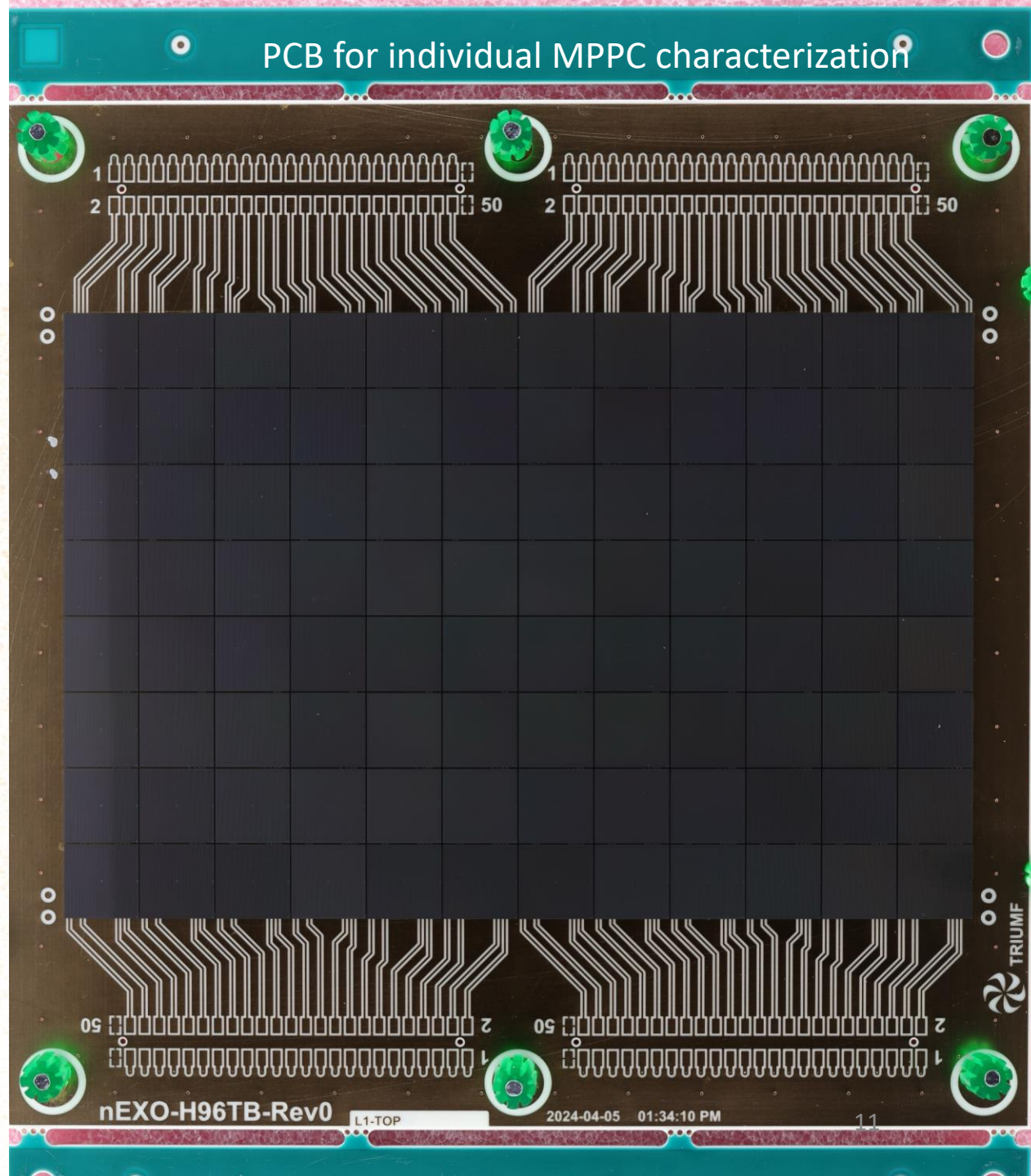

nEXO-H96TB-Rev0

L1-TOP

2024-04-05 01:34:10 PM

Moving away from SiPM to digital SiPM

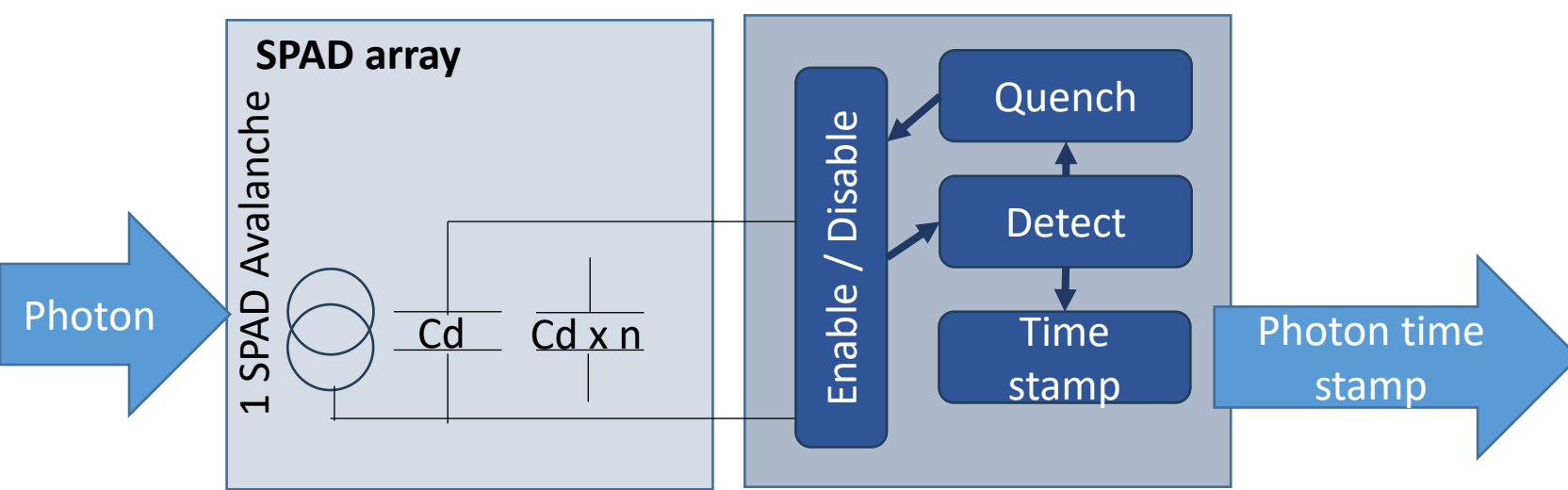
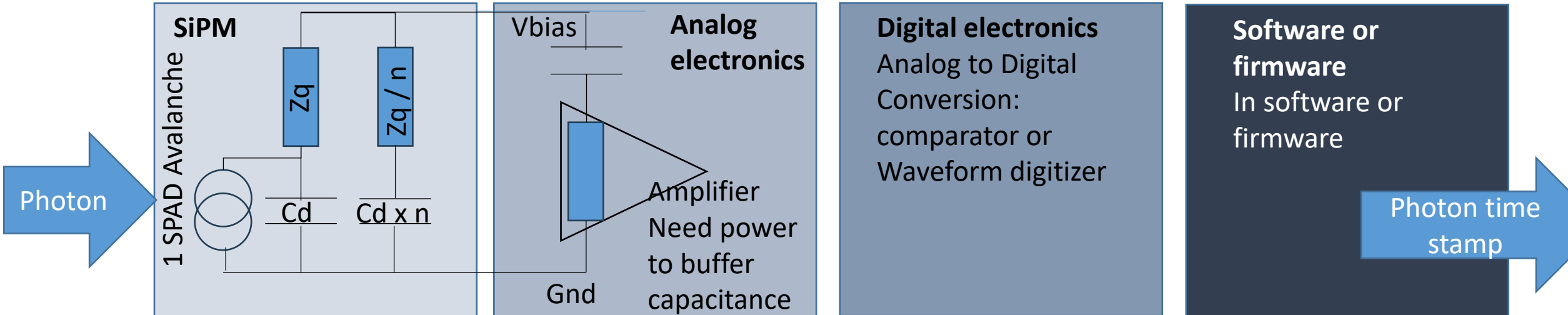

Photon to Digital Converter detour

- PDC developed for Astroparticle physics
- “Front-side” illuminated single photon detector
- Designed at U.Sherbrooke (QC, Canada)
- Built at Teledyne-DALSA (QC, Canada)

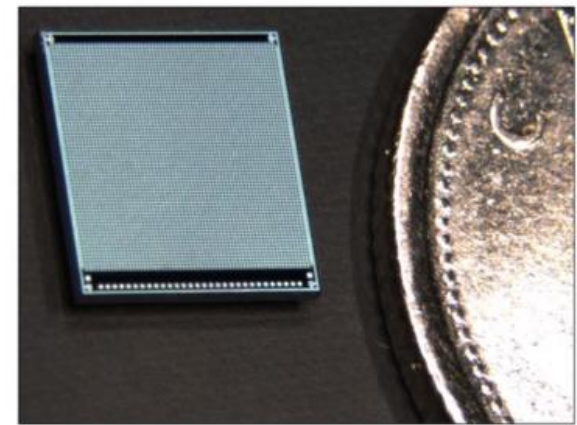
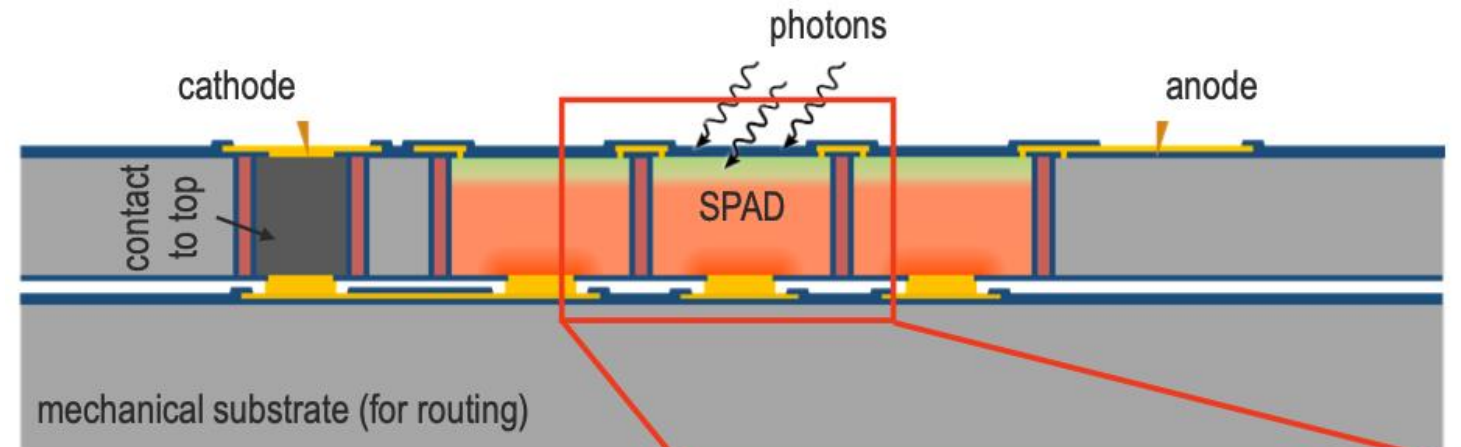

3D SPAD main die macro image (canadian 10¢ for reference)

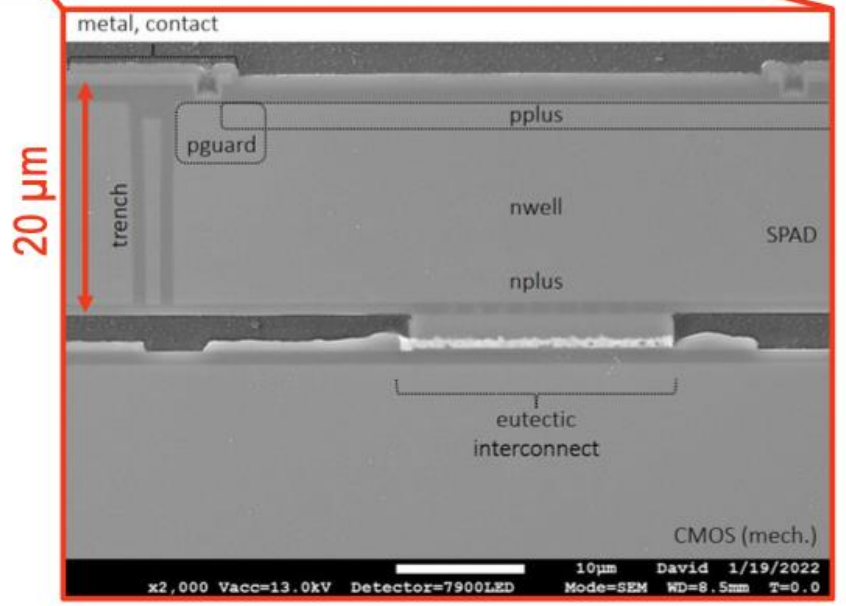

Parent, Samuel, et al. "Single photon avalanche diodes and vertical integration process for a 3D digital SiPM using industrial semiconductor technologies." 2018 IEEE Nuclear Science Symposium and Medical Imaging Conference Proceedings (NSS/MIC). IEEE, 2018.

Why PDC for nEXO

- Ability to time stamp every photons with ns scale resolution
 - Not achievable with analog due to power dissipation constraints
 - Efficient tagging of coincidence such as Bismuth-Polonium
 - May use timing for position reconstruction
- Ease of use. Only having to deal with digital signals
- But a few challenges
 - Efficiency at 175nm is low (<20%)
 - Dark noise rate to be optimized
 - Mass production not achieved yet

Leveraging our expertise for enabling new technologies

General Fusion Magnetized Target Fusion technology

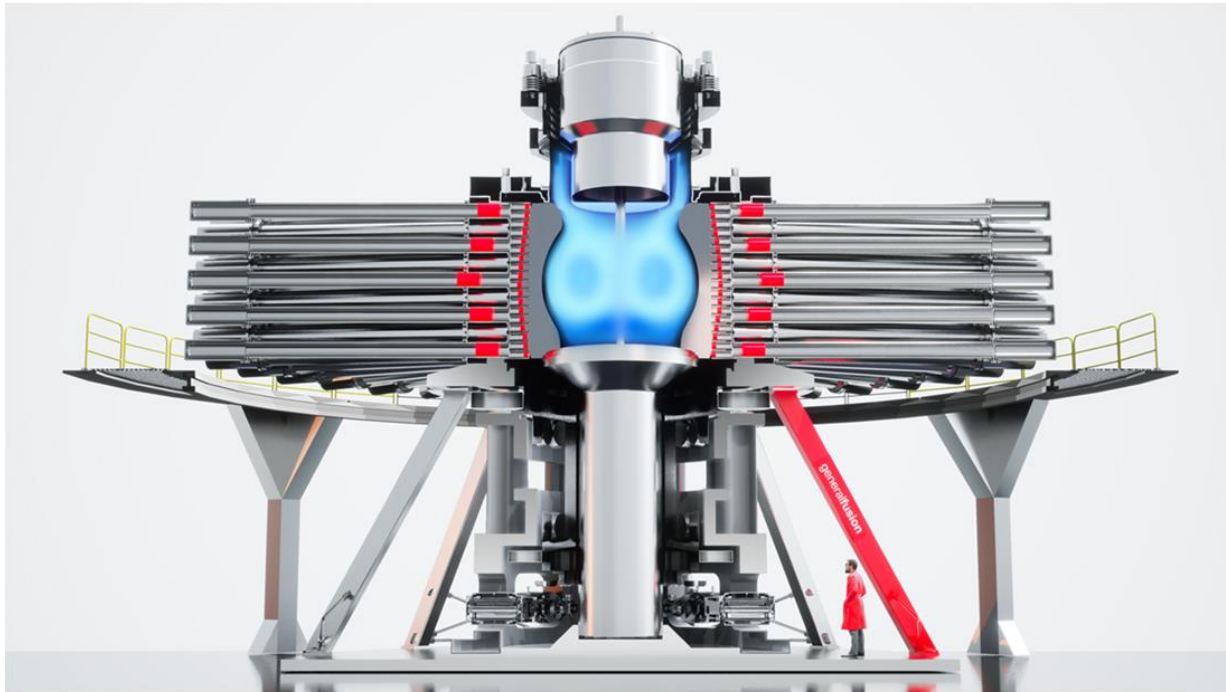

- In 2022, General Fusion contacted us regarding a solution for neutron spectrometry
 - Need to measure neutron energy
 - To demonstrate Fusion condition
 - Very high rate of neutrons for a short time

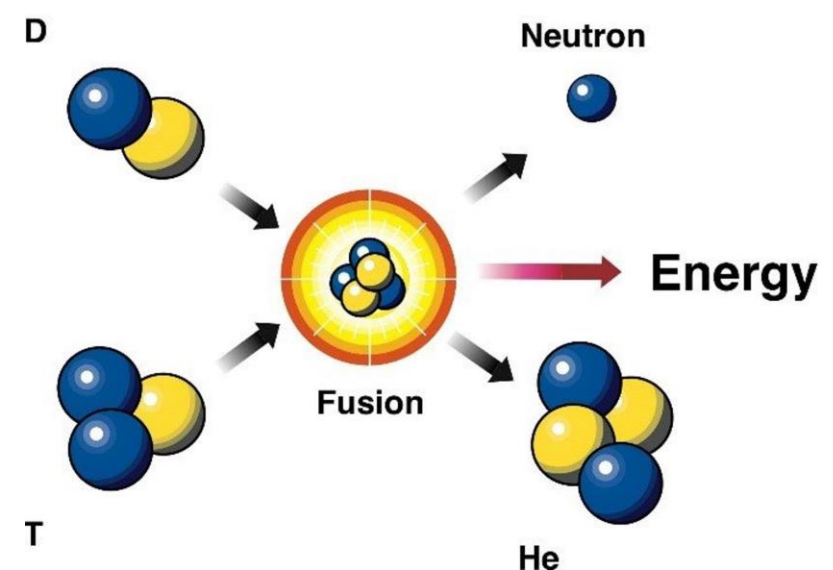

A rather unusual experiment

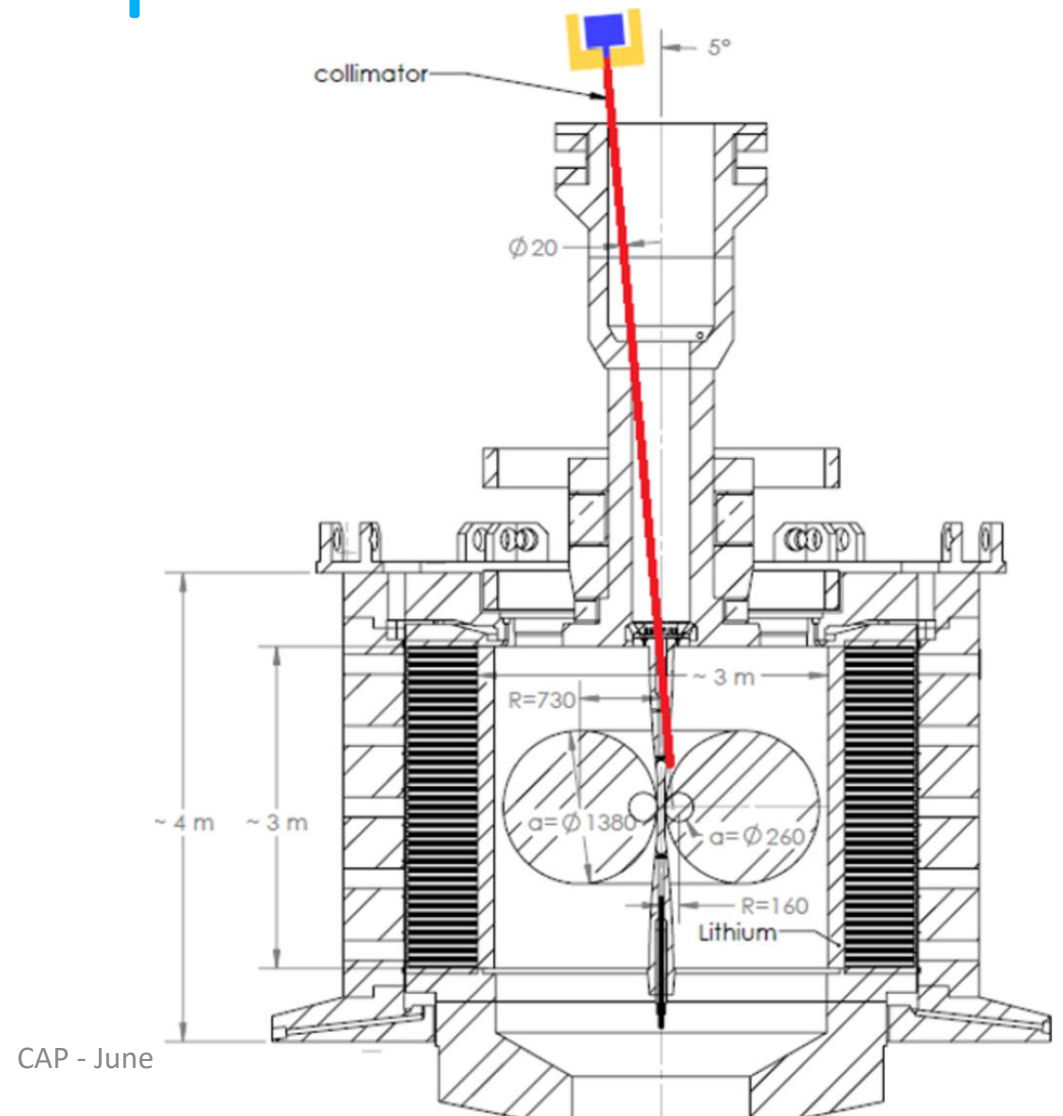

CAP - June

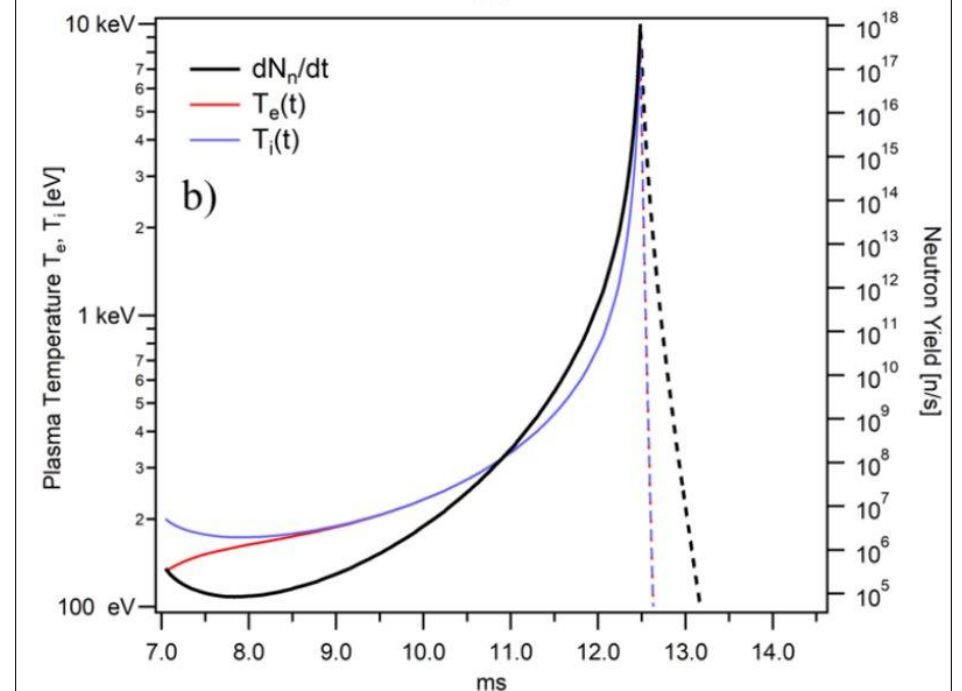
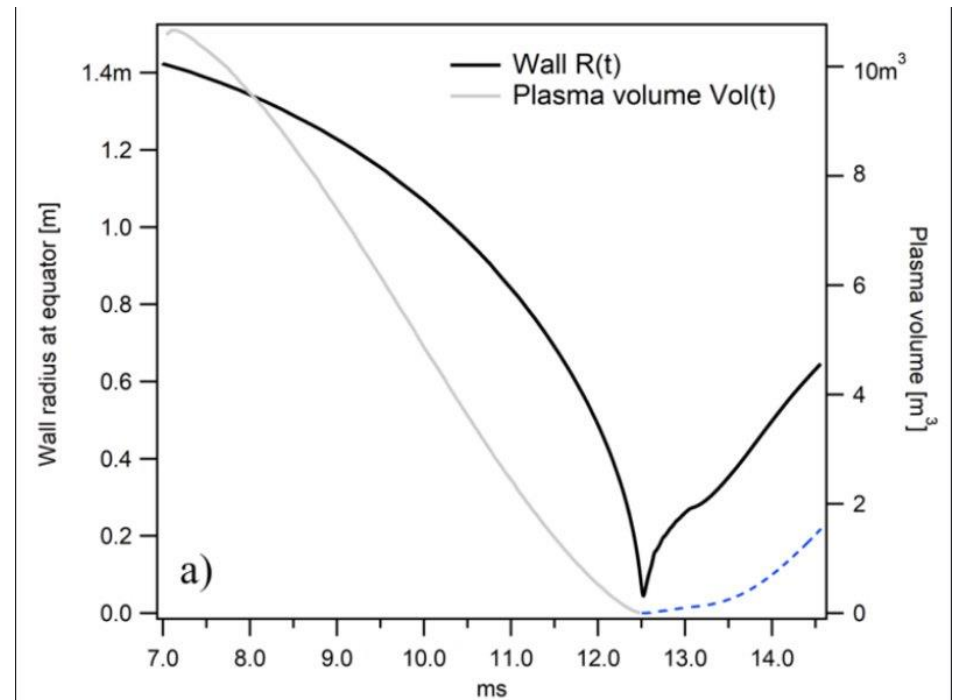

Time of flight spectrometry

- A well-known technique using plastic scintillators
 - Measure scattering angle
 - Measure time difference between first and second scatter
- Challenges due to rate
 - 1 neutron per ns in first layer
 - High segmentation
 - Fast response
 - Ambiguity associating layer 1 and layer 2
 - Minimize time of flight – so need outstanding timing resolution

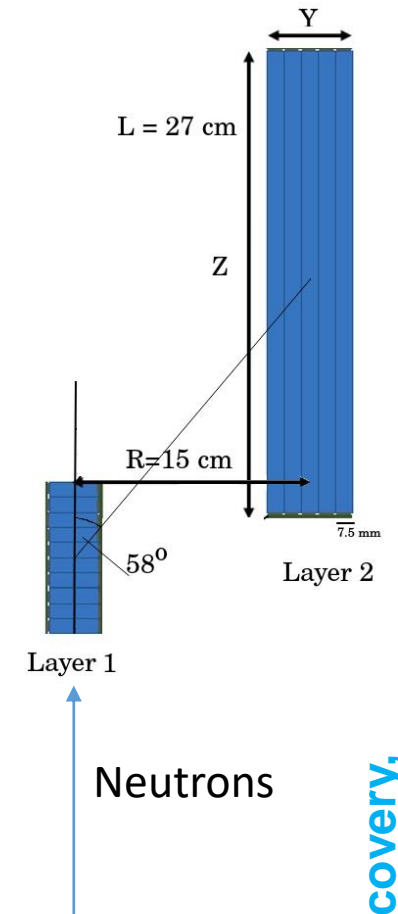
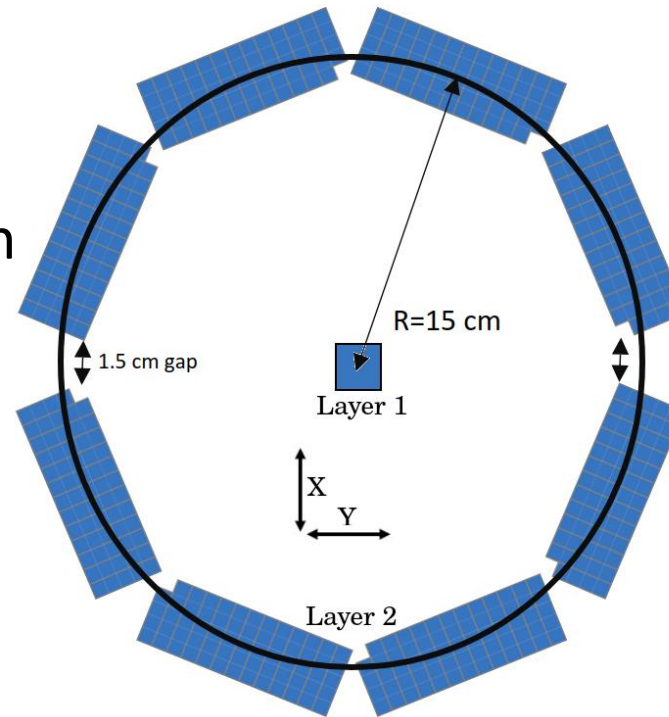

A SiPM-electronics challenge that would be alleviated using PDCs

- Extensive tail cutting required without scarifying timing resolution and minimizing power dissipation
 - Start with >100ns pulse width. Need <20ns after shaping

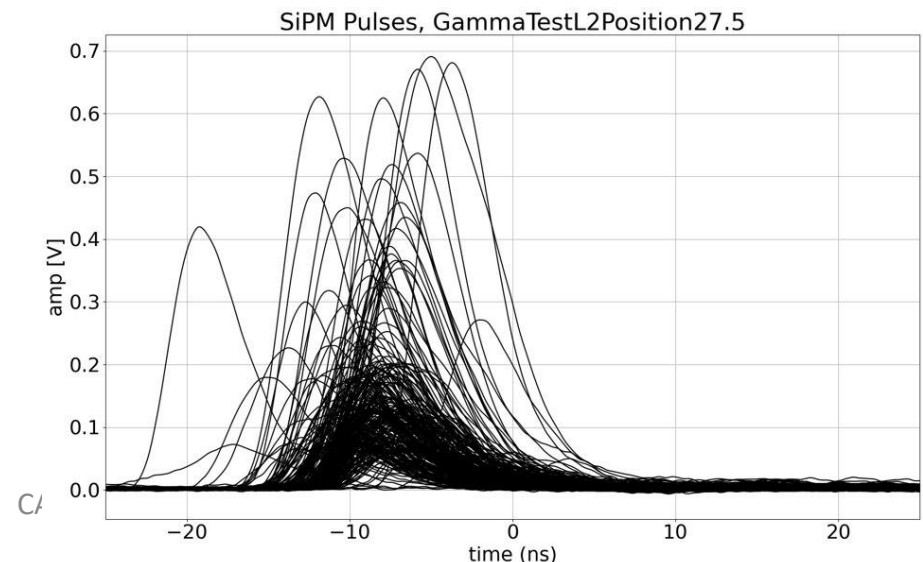

- Phase 2 will be to use PDC
 - Much easier to control SiPM recharge
 - Expect to achieve 100 MHz per channel
 - I.e. can detect 2 interaction separated by at least 10ns
- With analog SiPM, 20ns is probably as good as it gets
 - And we have not found a low power solution. Need 50-100 mW per channel for front end

Towards first experiment early 2027

- Complete single channel validation by end of 2025
 - Using analog SiPMs + analog electronics
- Build the detector system by end of 2026
 - 128 channels for layer 1
 - About 1000 channels for layer 2
- In parallel, develop layer 1 readout using PDC in 2026
- Start data taking in 2027 if General Fusion can deliver
 - Upgrade to PDCs as soon as possible
- This is really like a physics experiment
 - Made possible by NSERC ALLIANCE with General Fusion

But, can we afford to wait for green energy or is it already too late?

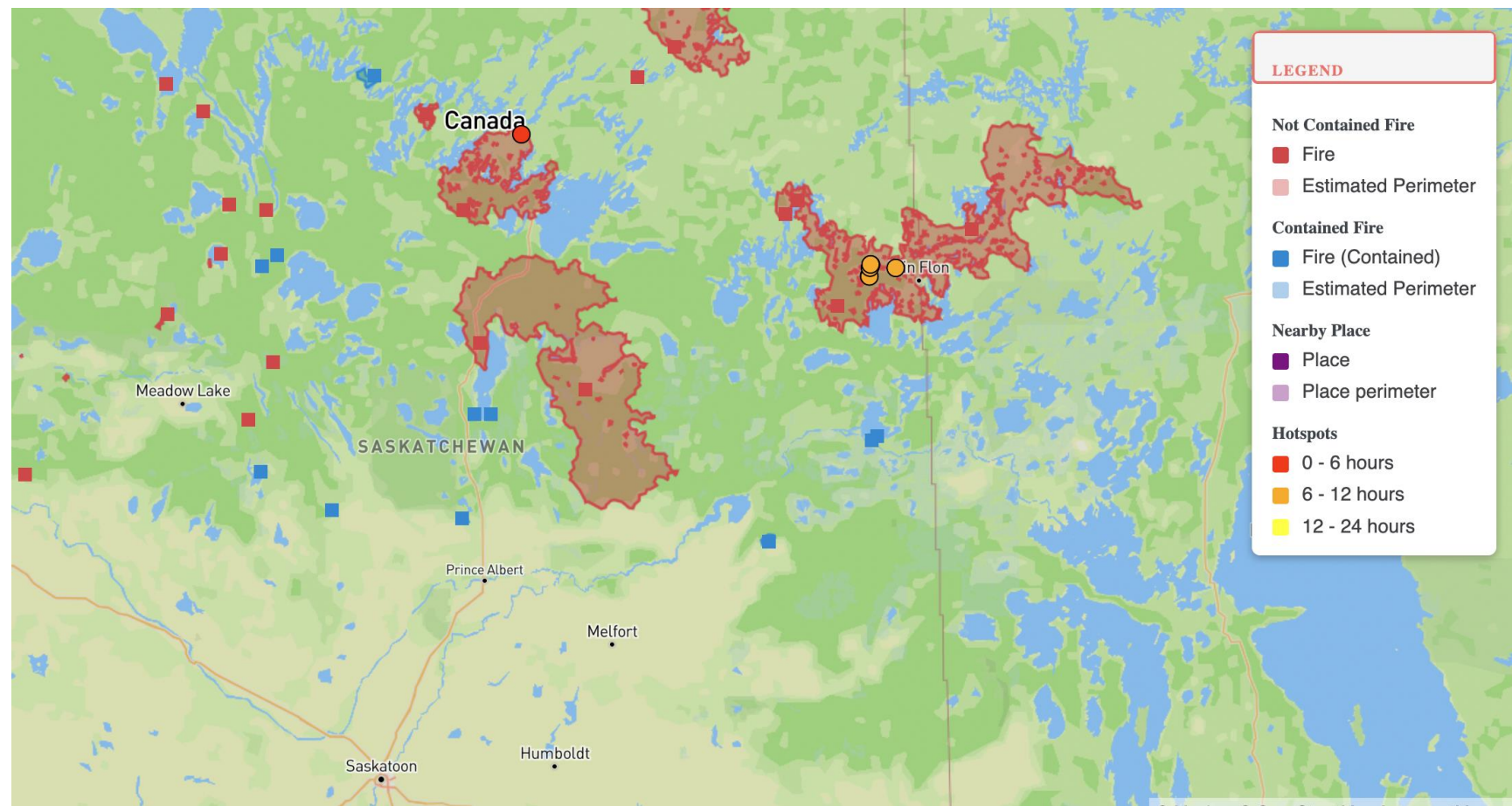

Suppressing forest fire before the become catastrophic – A multi-prong challenge

- The detection
 - What modality? Imaging from space, drone operated, static systems?
 - In remote area most fires are started by lightning – somewhat predictable – drone fleet
 - Humans start most fires in area they access – hard to predict – static arrays
 - Our strategy #1: rely on diffusion + wind to bring the signal to our sensors whether static or drone mounted.
 - Our strategy #2: measure smoke because we can use SiPM/SPAD technology
- The suppression
 - When is it too late? How quickly can a fire be put out vs their size and the environment
- The decision
 - When to put out a fire vs letting it burn?

Smoke (particulate) detection technology

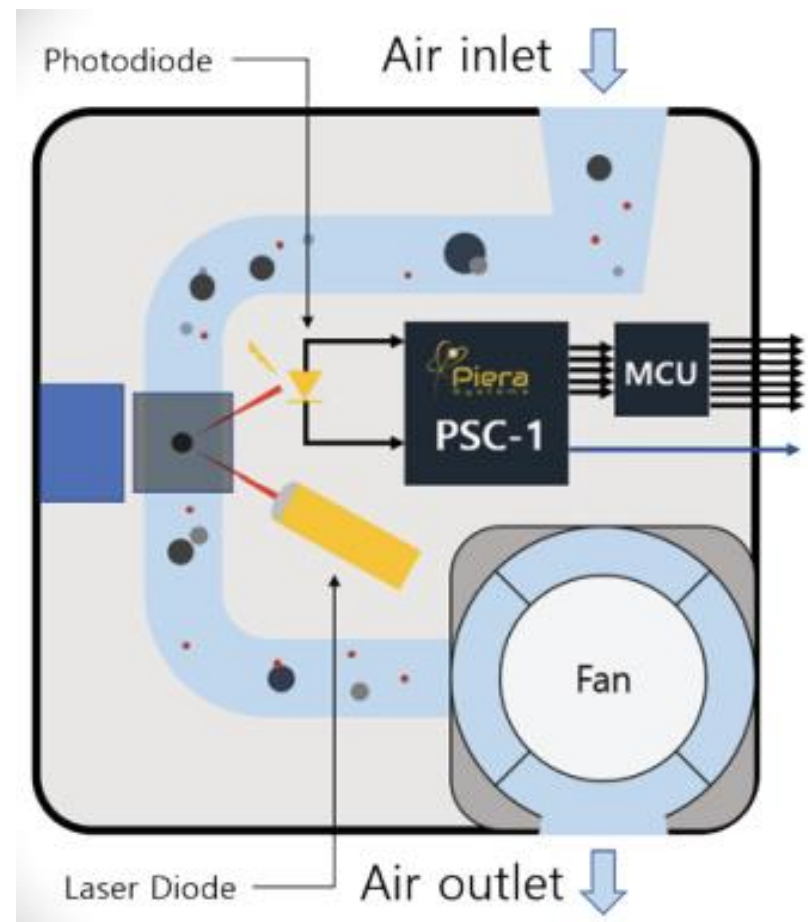

Based on Mie scattering detection

Commercial units rely on a single photo-diode
Low noise electronics in an ASIC + AI

Designed primarily in Mississauga, ON
80\$/unit



Most recent technology



About us Products Career **Bosch Sensortec** 🔍 ☰

Home > Products > Environmental sensors > Particulate matter sensor > BMV080

Particulate matter sensor BMV080

Tiny. Noiseless. Fanless. Maintenance-free.

- Measure Mie (back) scattering in free space
 - No more enclosure
- Still using photo-diode

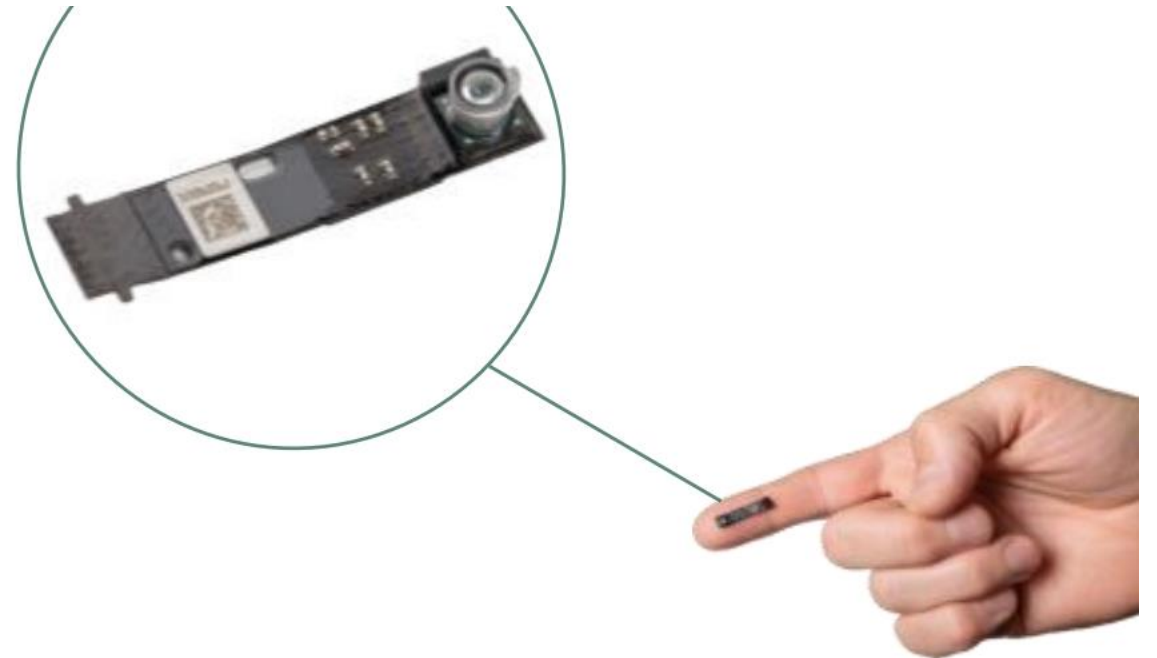

Our concept using SiPMs (2021-2022)

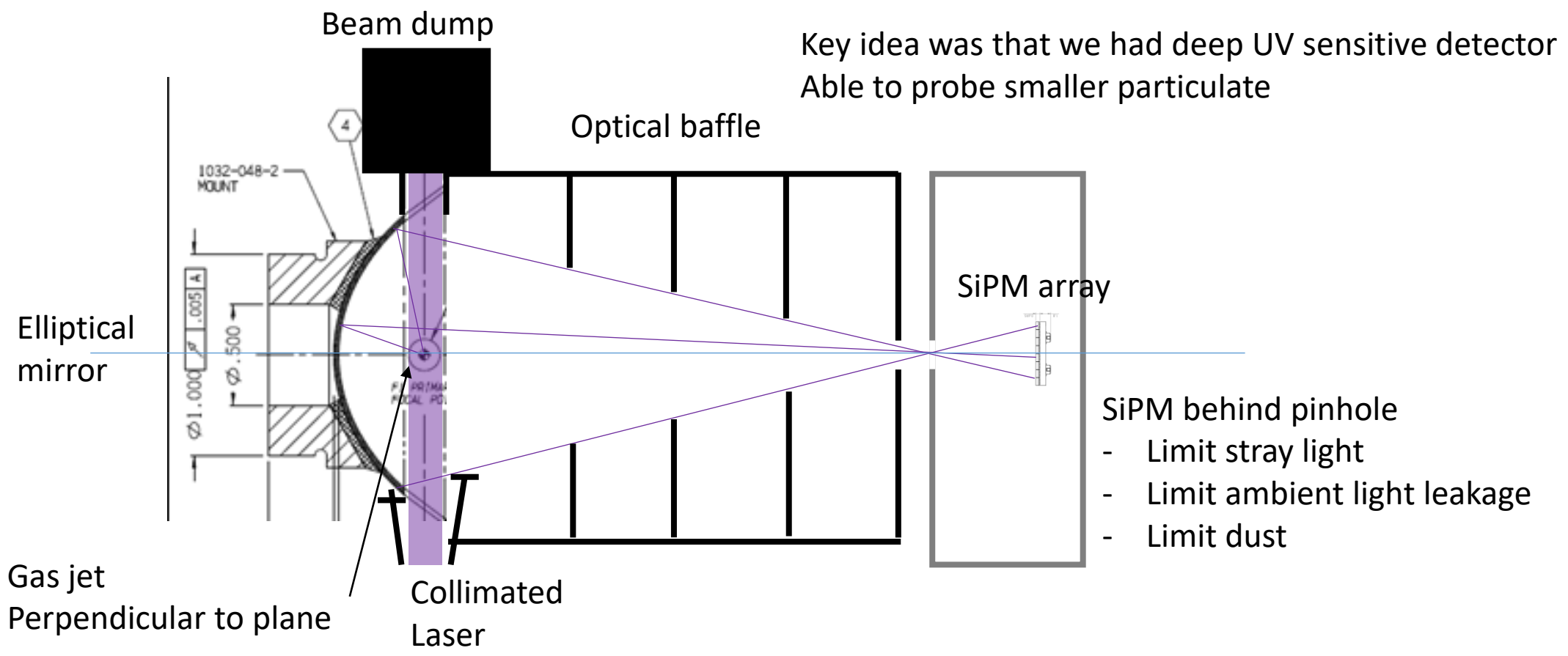

Working concept!

Comparing SPAA and Piera with smoke injection at 50 seconds

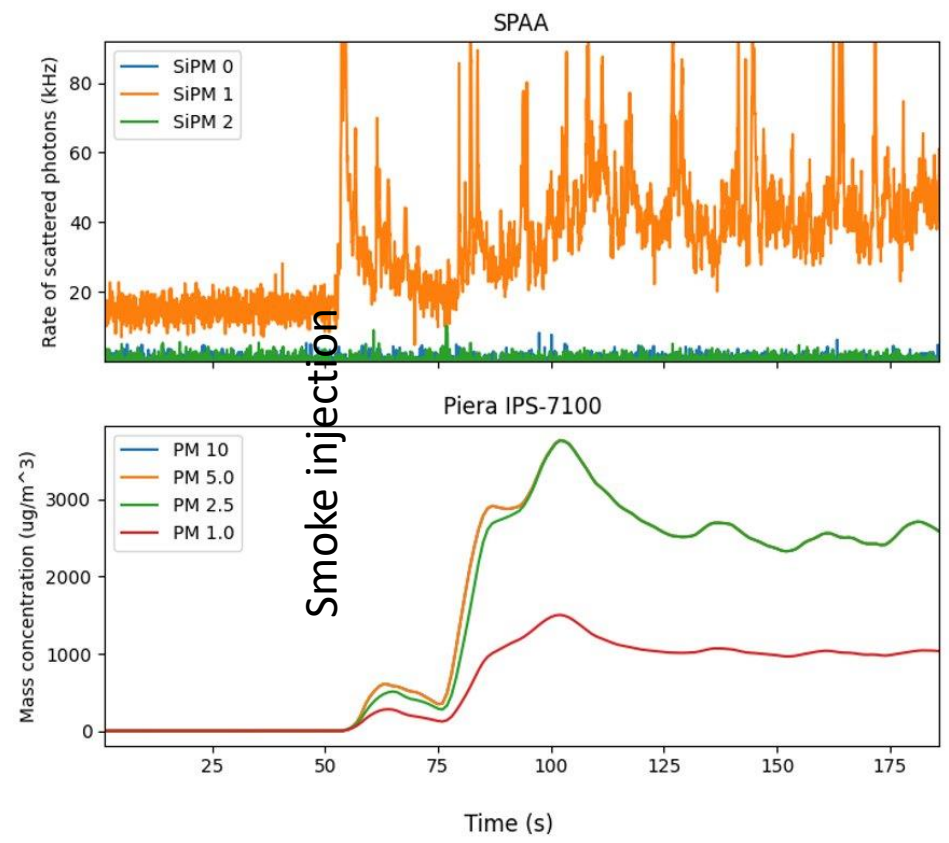

- Demonstrated over the summer 2022
- Photon counting is compelling
- New design coming. Easier to build

Moving to digital SiPM

Side view

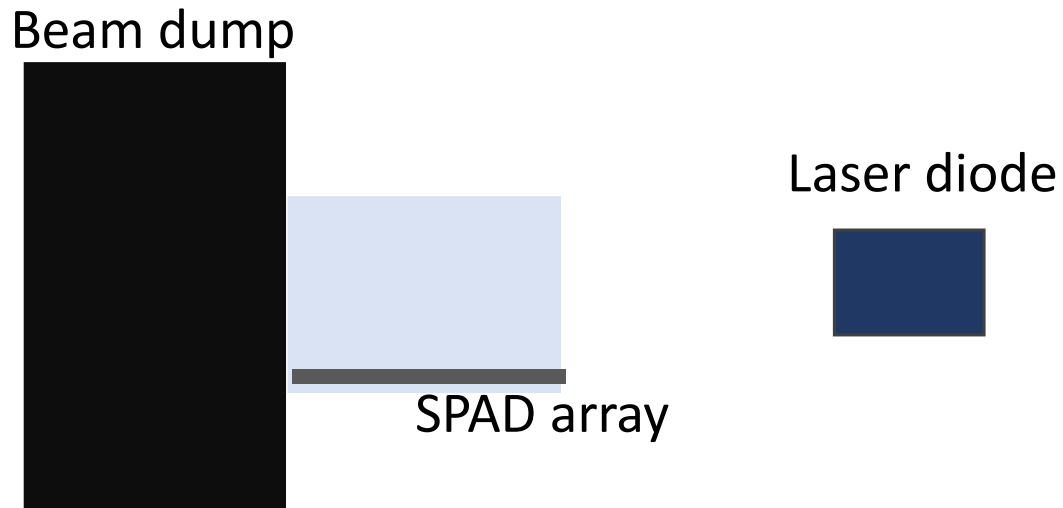

Top view

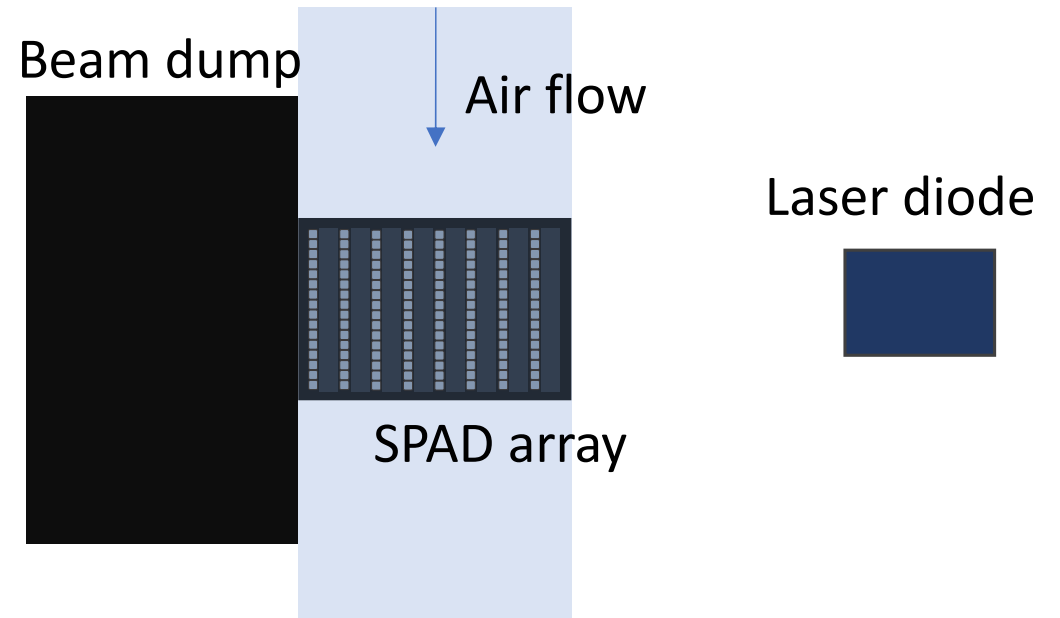

- Much lower power than photo-diode and much higher performances due to built-in segmentation
- Design to enable stand-alone operation for >4 months

Summary and outlook

- Long journey from nEXO to General Fusion NES to smoke detection
 - We built extensive expertise and capabilities
 - Our focus shifted overtime from fundamental physics to tackling pressing issues linked to climate change
- Where do we go from there?
 - Build a community to address the challenge of managing forest fire in Canada. Global warming is here, mitigation is required.
 - Build a sensor network from Vancouver North Shore to Squamish by 2030
 - May not make most sense but this is a symbolic example
 - Too ambitious for academia alone. We will work with companies (especially SenseNet) and we may create a spin-off
 - We want/need to move fast. If you are tired of the snail pace of academia, talk to me!

Where work and play meet.
Nuclear physics technologies can
rescue our environment



Scintillation detection concept

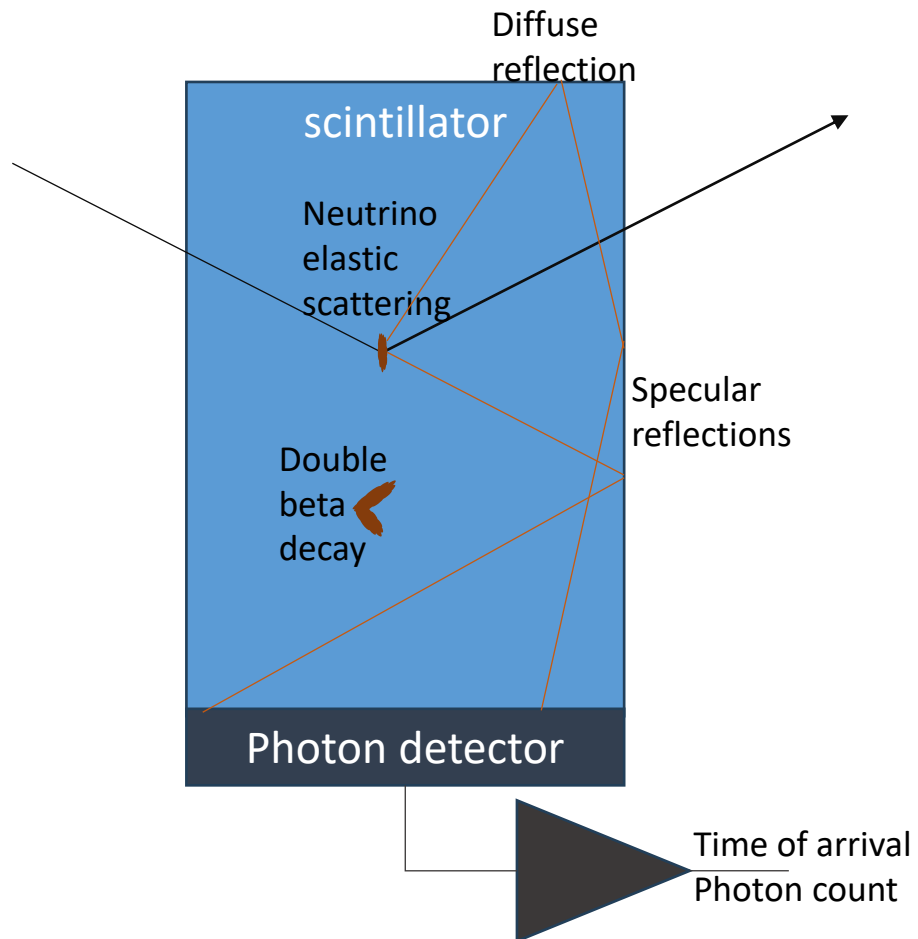

- Physics process
 - Neutrino scattering
 - **Double beta decay**
 - ... Ionizing particle, gamma ray, **neutron**
- Energy deposited
- Scintillation light produced
- Light (photons) propagate
- Photons are detected
- Electronics converts photon signal into digital information

PDC detour

- **Versatility**

- Visible to IR via thickness control
- Deep UV through Back-side surface processing
 - Unconventional Anti-reflective coating: black silicon, graphene, 3D structures

- **Non-photon detection**

- Minimum ionizing
- keV scale electron (hybrid photo-detector)
- Dark matter

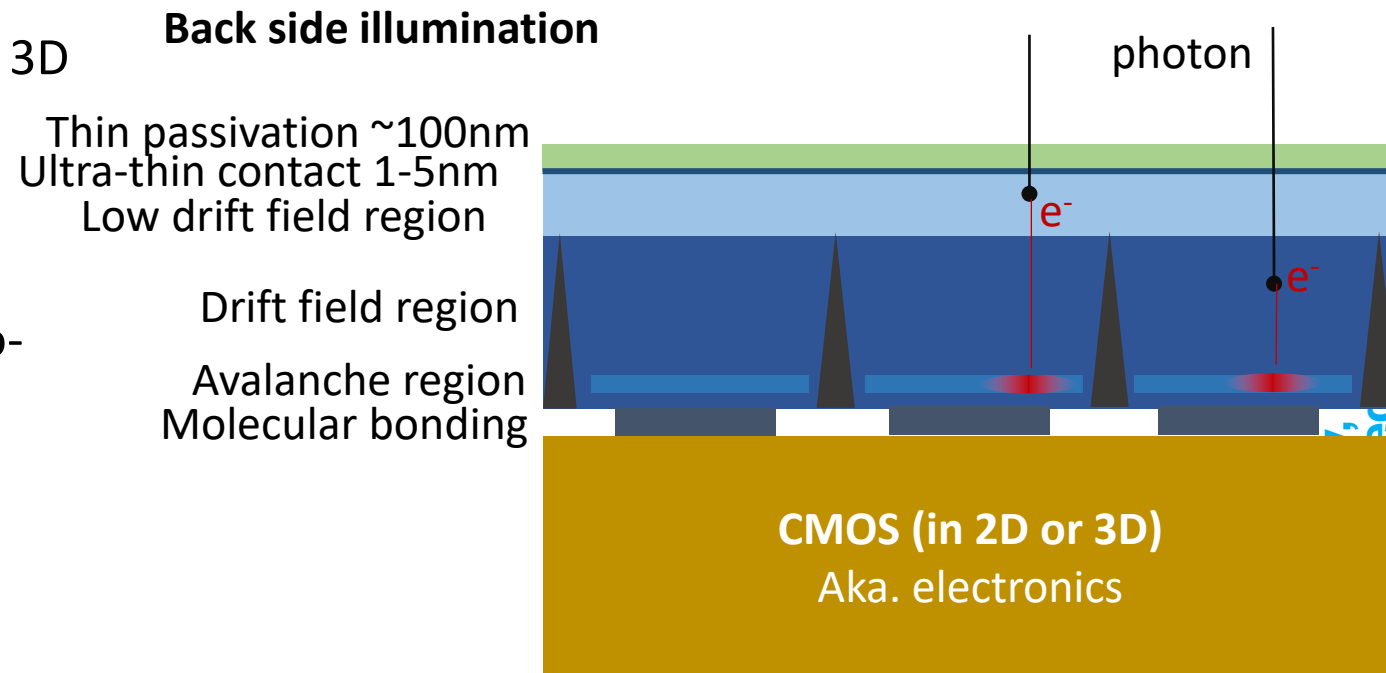
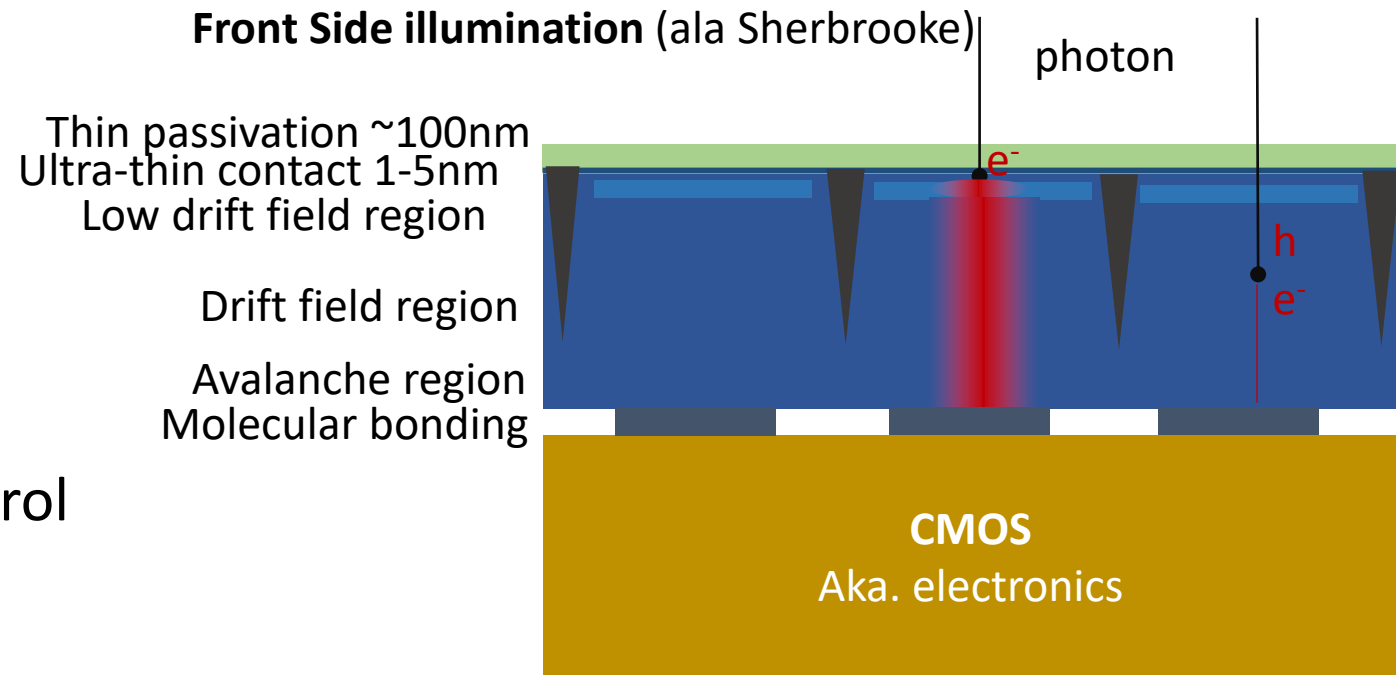

Gamma as neutron proxy

- Back-to-back 511 keV gammas
- Left side - BaF₂ detector to time stamp interaction time
- Right side – Compton scatter in plastic bar
 - Gamma produce 8-10 times more scintillation than neutrons
 - 100 keV Compton scatter ~ 1 MeV neutron scatter
- Right side - CeBr₃ to measure energy of scattered gamma

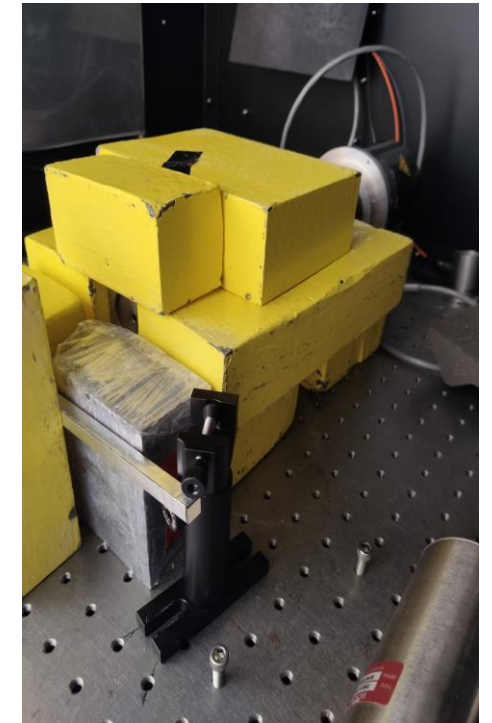
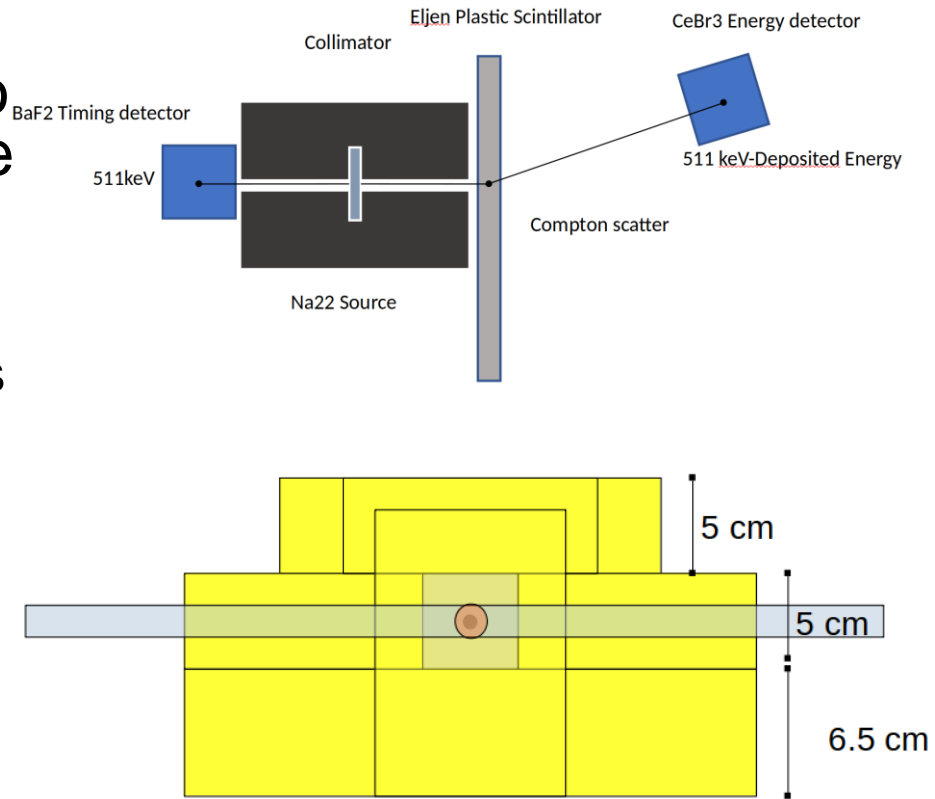

Probing performances in LXe

- Light only Liquid Xenon (LoLX)
 - Carleton, McGill, Pisa, Sherbrooke, TRIUMF collaboration
- Validating performances of SiPMs in LXe
- Studying light production in LXe
 - Scintillation and Cerenkov
 - Energy resolution
- See talk by A. Li on Monday

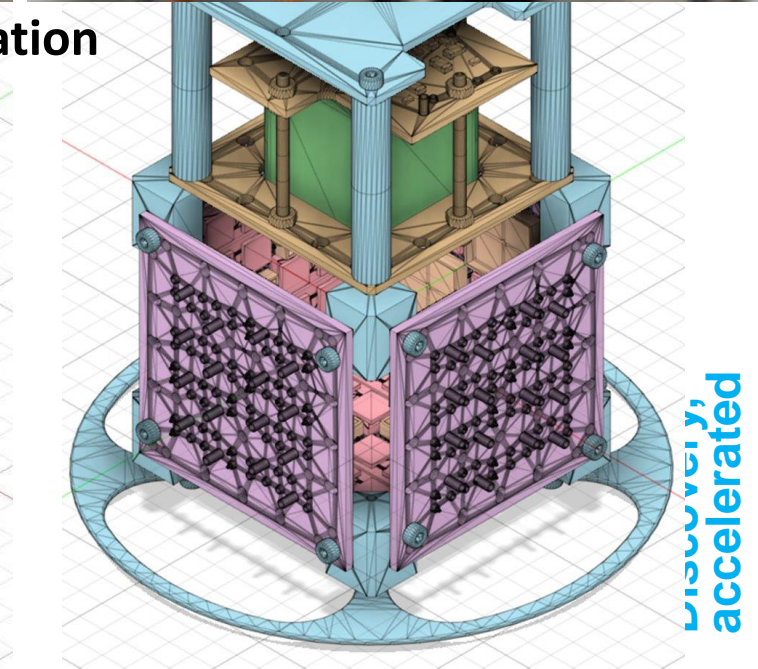
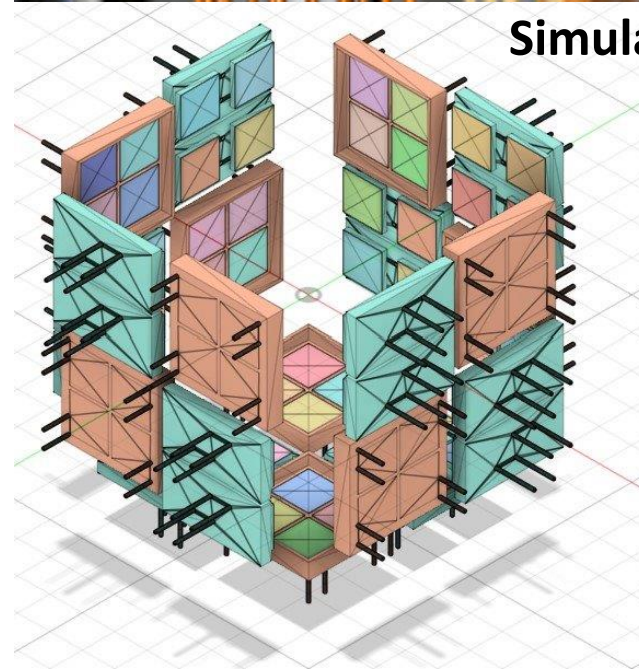
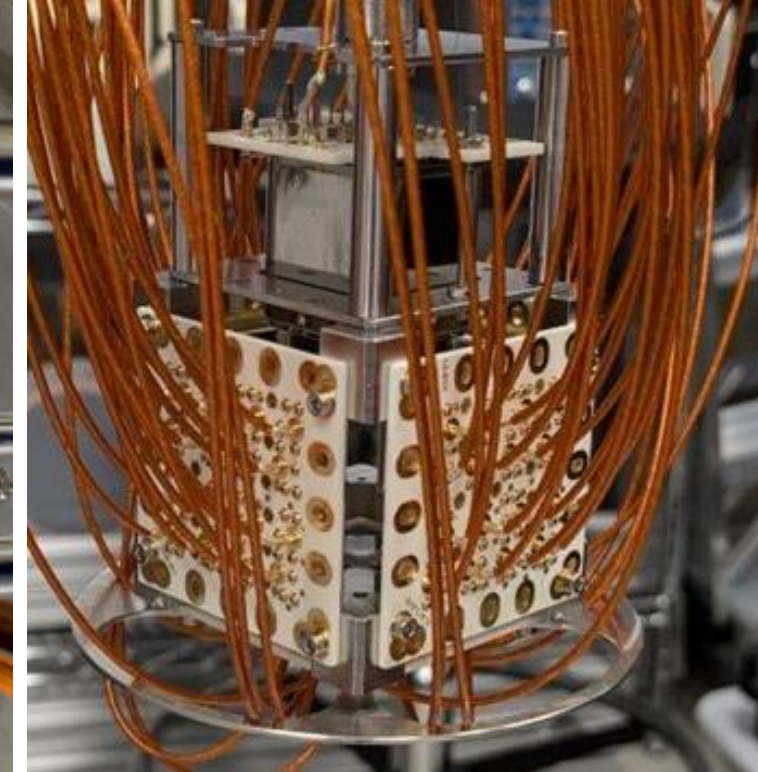
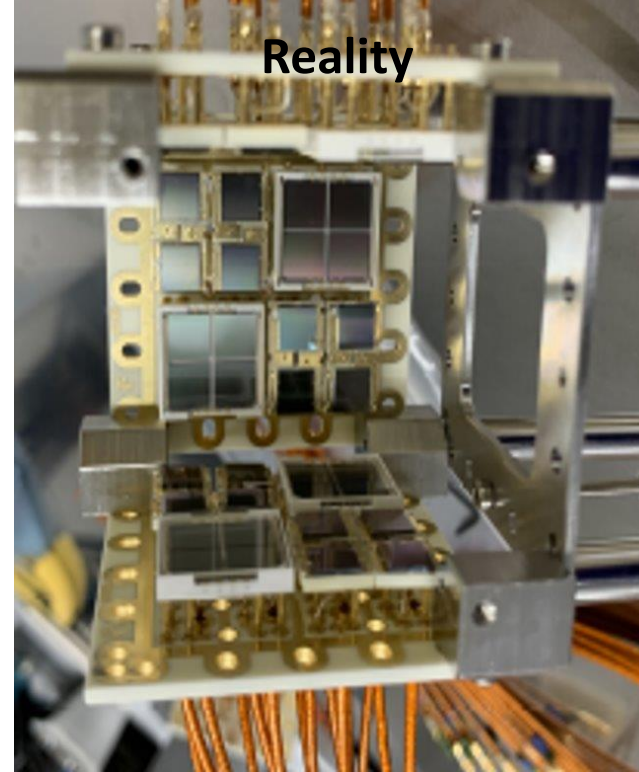

Asset: Vacuum Ultra-Violet Efficiency reflectivity and Absorption setup (VERA)

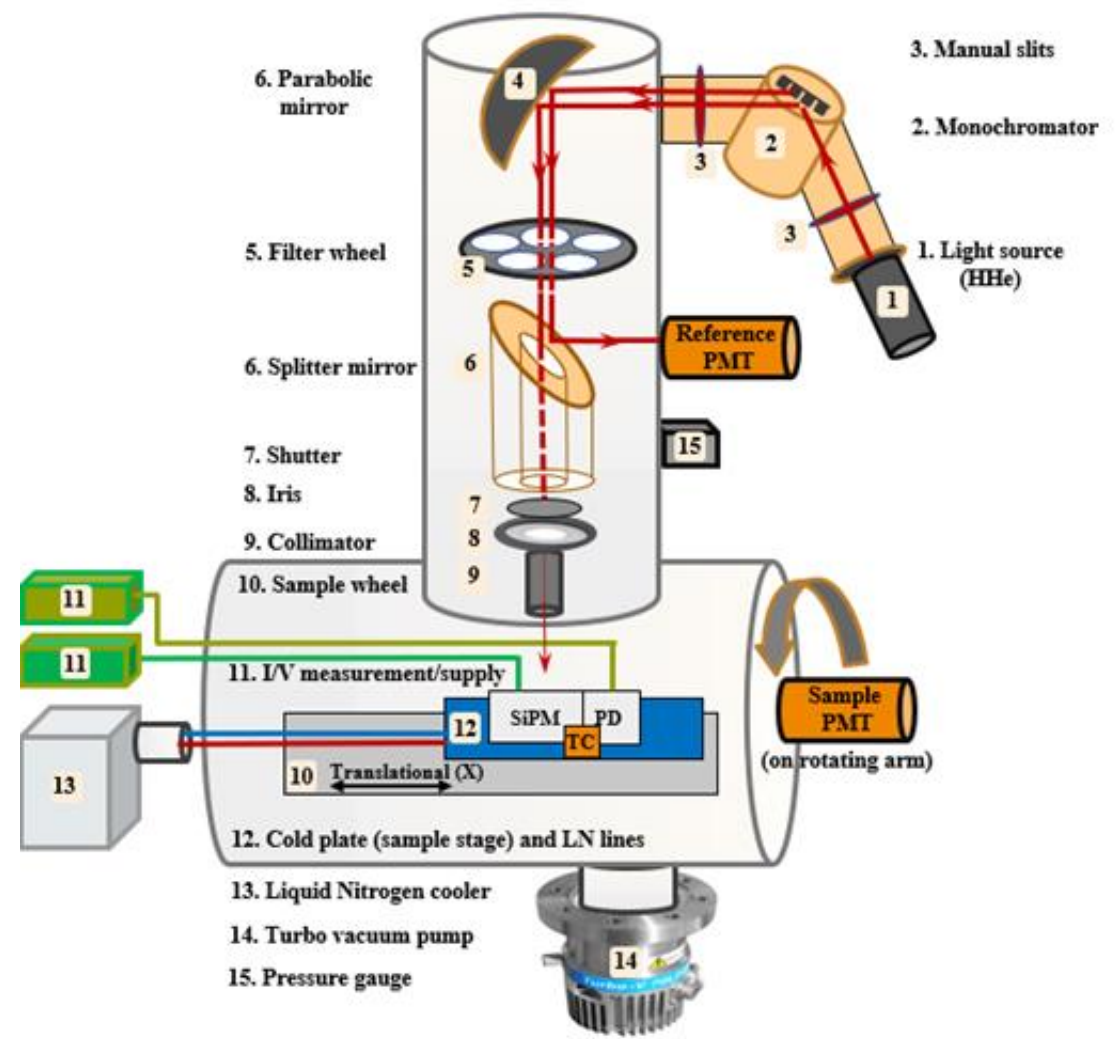

For example: inferring the number of electrons produced per VUV photon

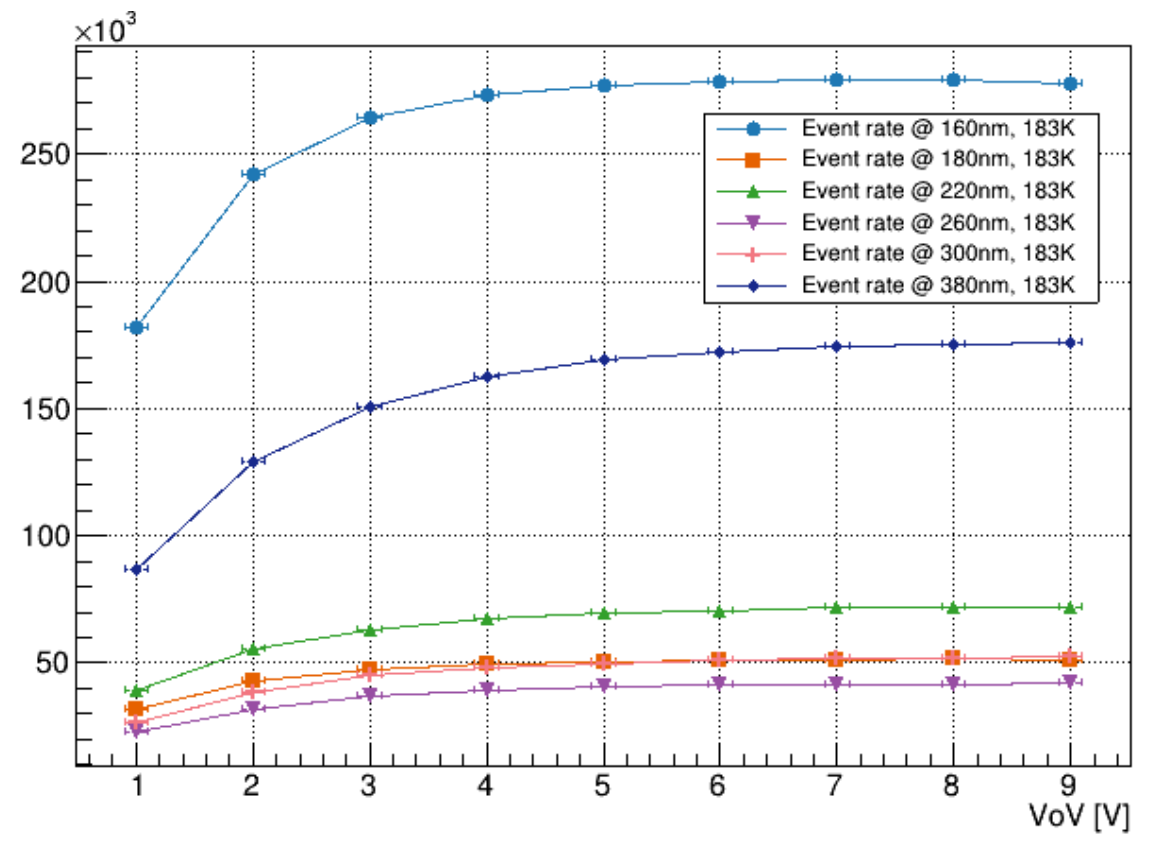

Asset: MIEL

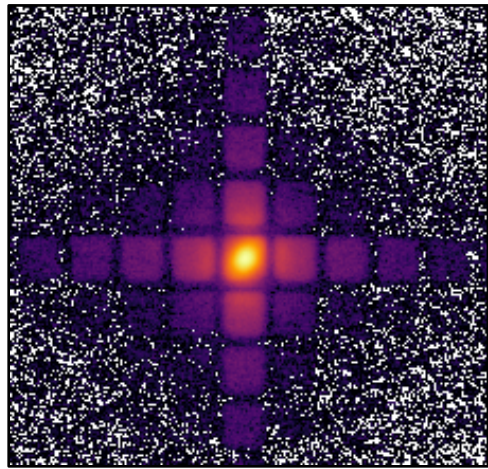
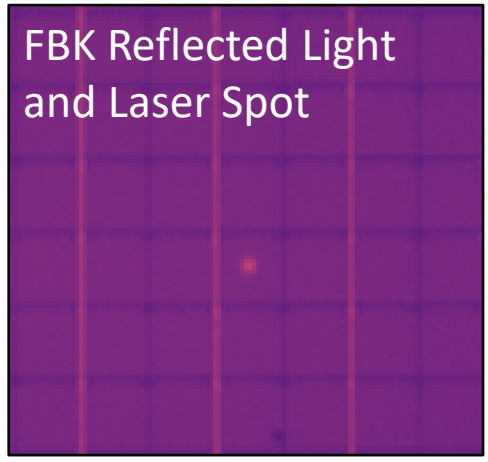
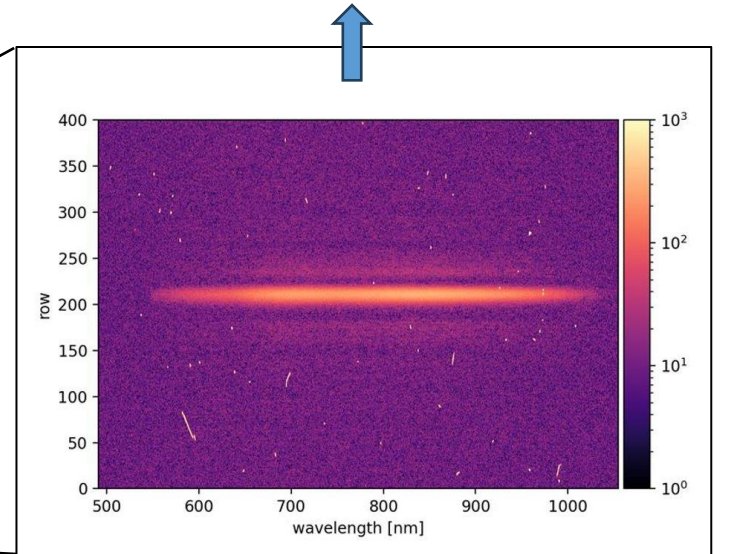
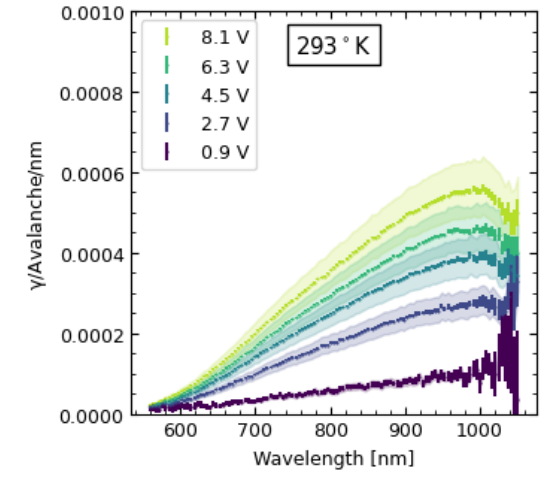
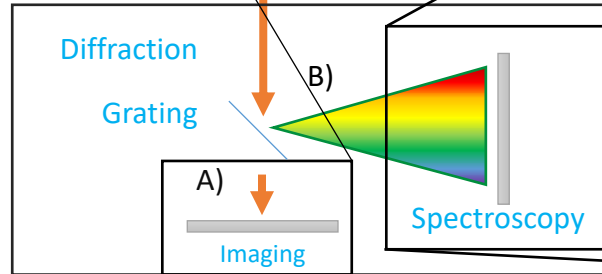
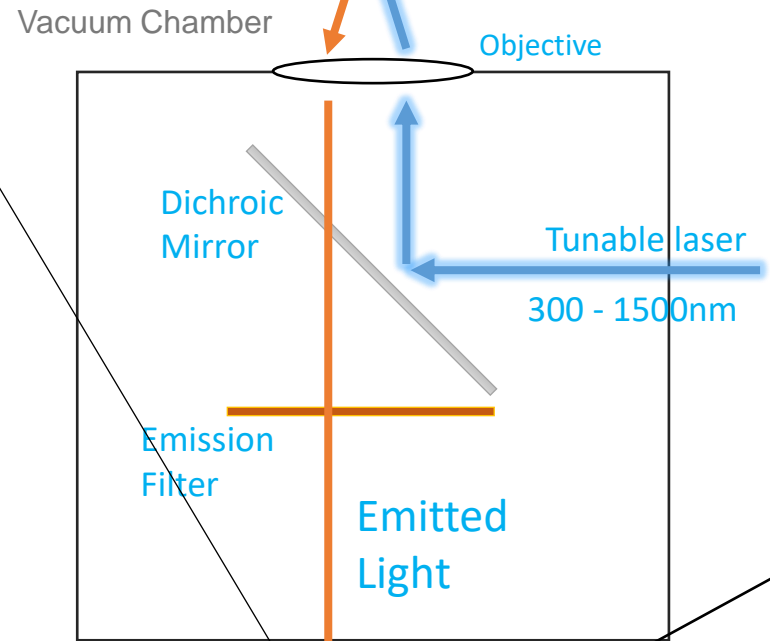
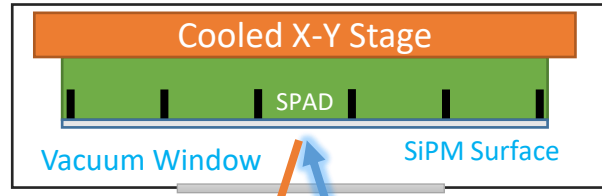

GAP June 11, 2019

nEXO - a steppingstone to expanding SiPM expertise

- nEXO leveraged earlier work
 - T2K Fine Grain Detector 2007-2011. First use of SiPMs in physics experiment
 - SiPM for Positron Emission Tomography
 - Main deliverable was a PET/MR insert led by U. Manitoba
- nEXO provided
 - State of the art equipment and personnel
- nEXO and LAr DM enabled emergence of digital SiPMs in Canada
 - Sherbrooke's Photon to Digital Converter
 - My vision: the next decade will see digital SiPMs eliminate analog ones
 - Canada will pave the way – driven by applied projects

Evolution of SiPM R&D at TRIUMF

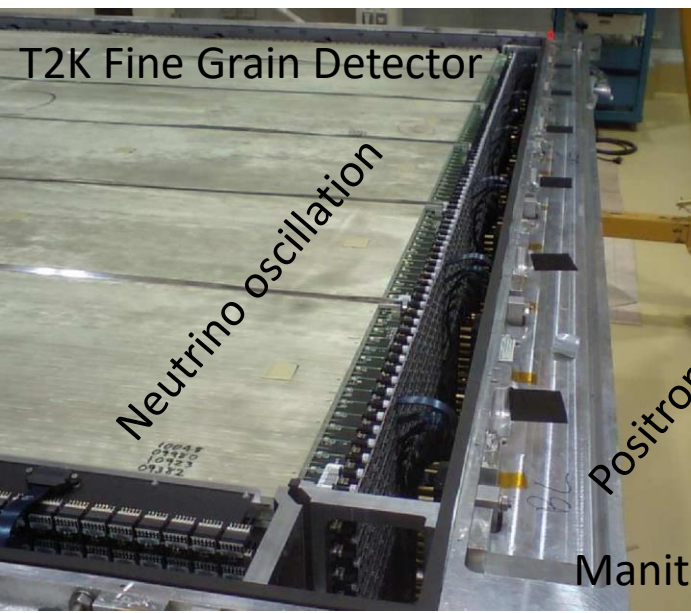

T2K Fine Grain Detector

Neutrino oscillation

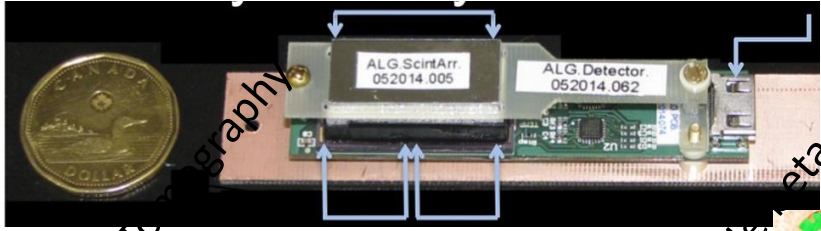

Positron Emission Tomography

Neutrinoless double beta decay

Manitoba PET/MR insert

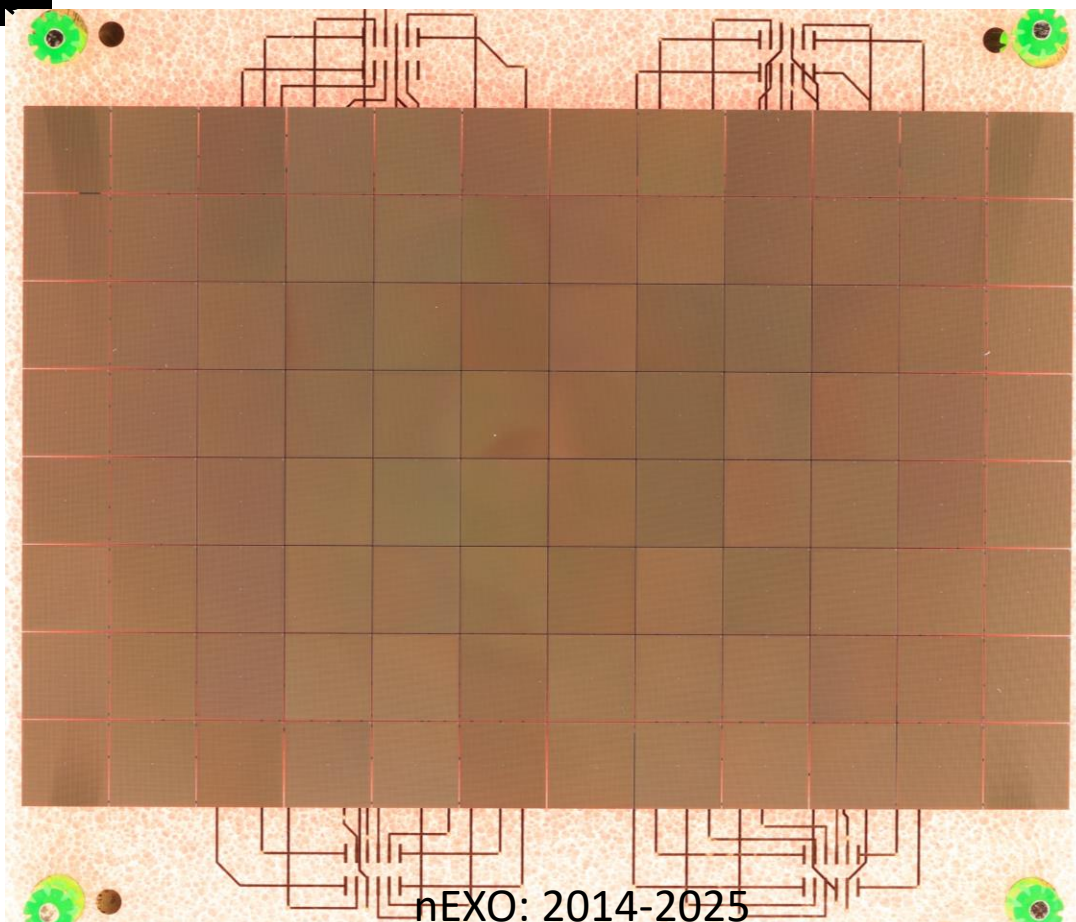

nEXO: 2014-2025