

A water-Cherenkov muon veto for the nEXO $0\nu\beta\beta$ experiment

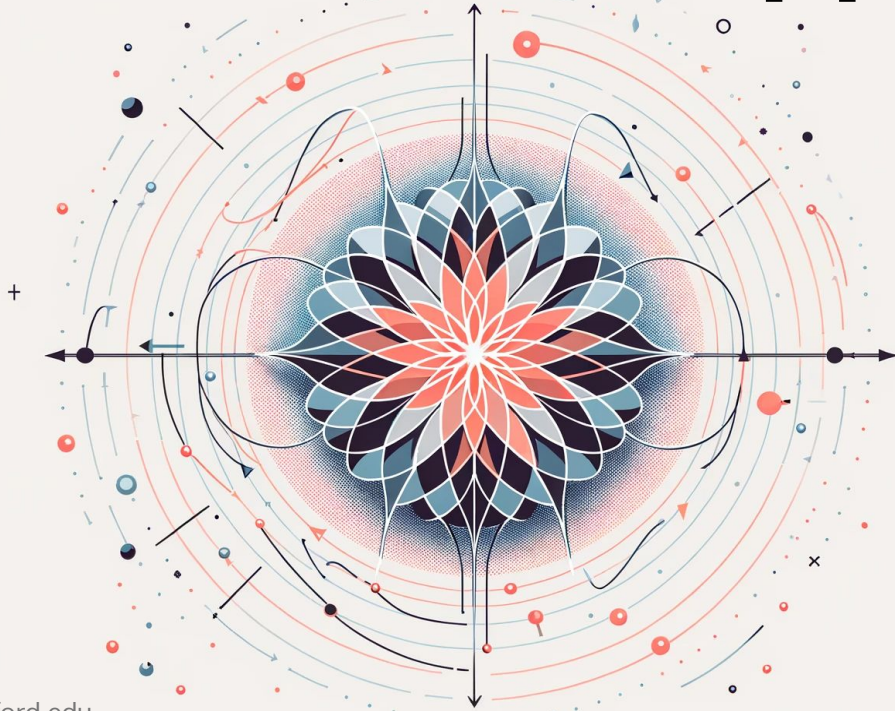

Soud Al Kharusi
CAP Congress 2024
May 29th 2024



soudk@stanford.edu

<https://www.soudkharusi.com/>

[Google Slides link](#)

Supervisors: Thomas Brunner & Daryl Haggard

A water-Cherenkov muon veto for the nEXO $0\nu\beta\beta$ experiment

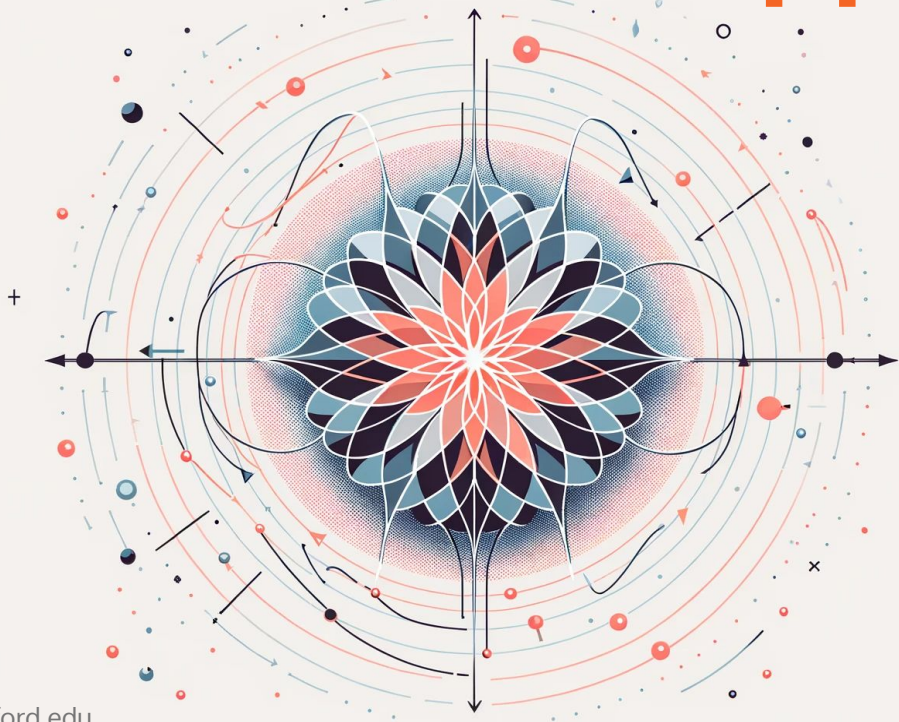

Soud Al Kharusi
CAP Congress 2024
May 29th 2024

nEXO 



Supervisors: Thomas Brunner & Daryl Haggard

soudk@stanford.edu

<https://www.soudkharusi.com/>

Beta decay

Your favourite β -unstable nucleus $N = (Z, A)$

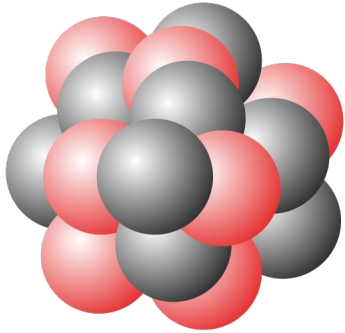

Your favourite more stable nucleus $N = (Z+1, A)$

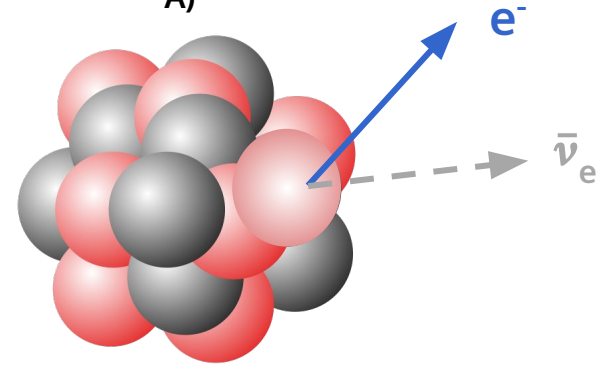

Double beta decay ($2\nu\beta\beta$)

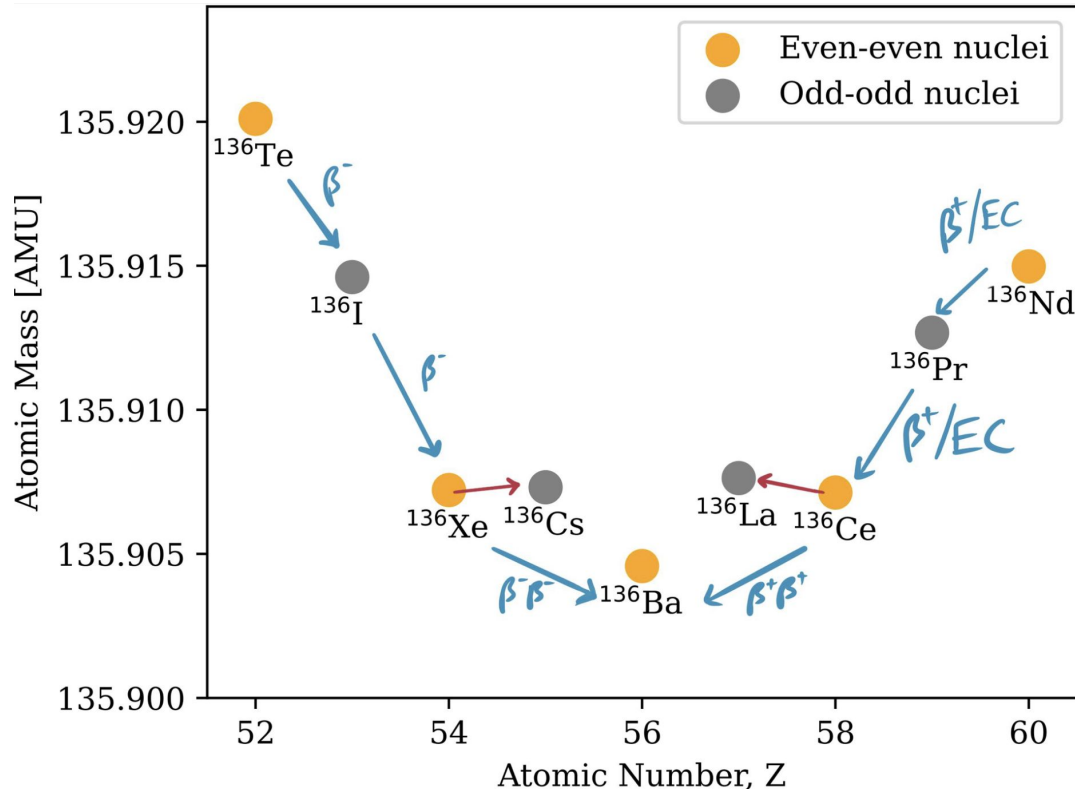

Double beta decay ($2\nu\beta\beta$)

^{136}Xe

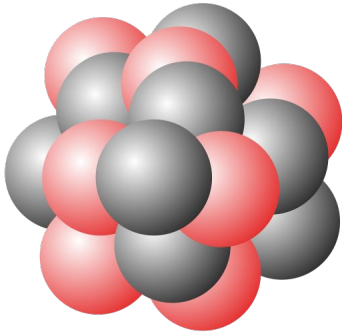

Double beta decay ($2\nu\beta\beta$)

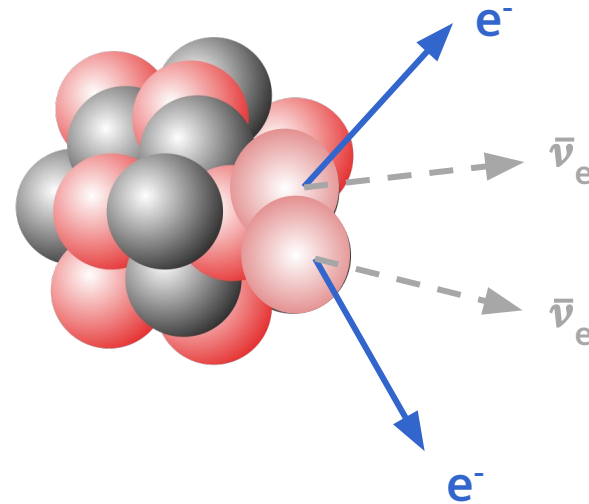
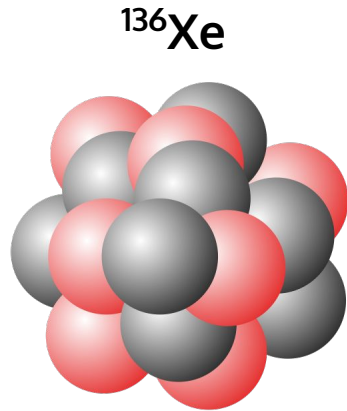

$$T_{1/2}(2\nu\beta\beta) \sim 10^{21} \text{ years}$$

Double beta decay ($2\nu\beta\beta$)

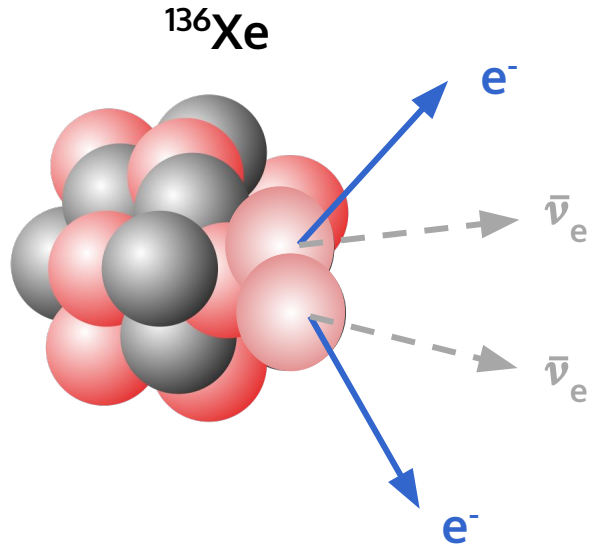

Double beta decay ($2\nu\beta\beta$)

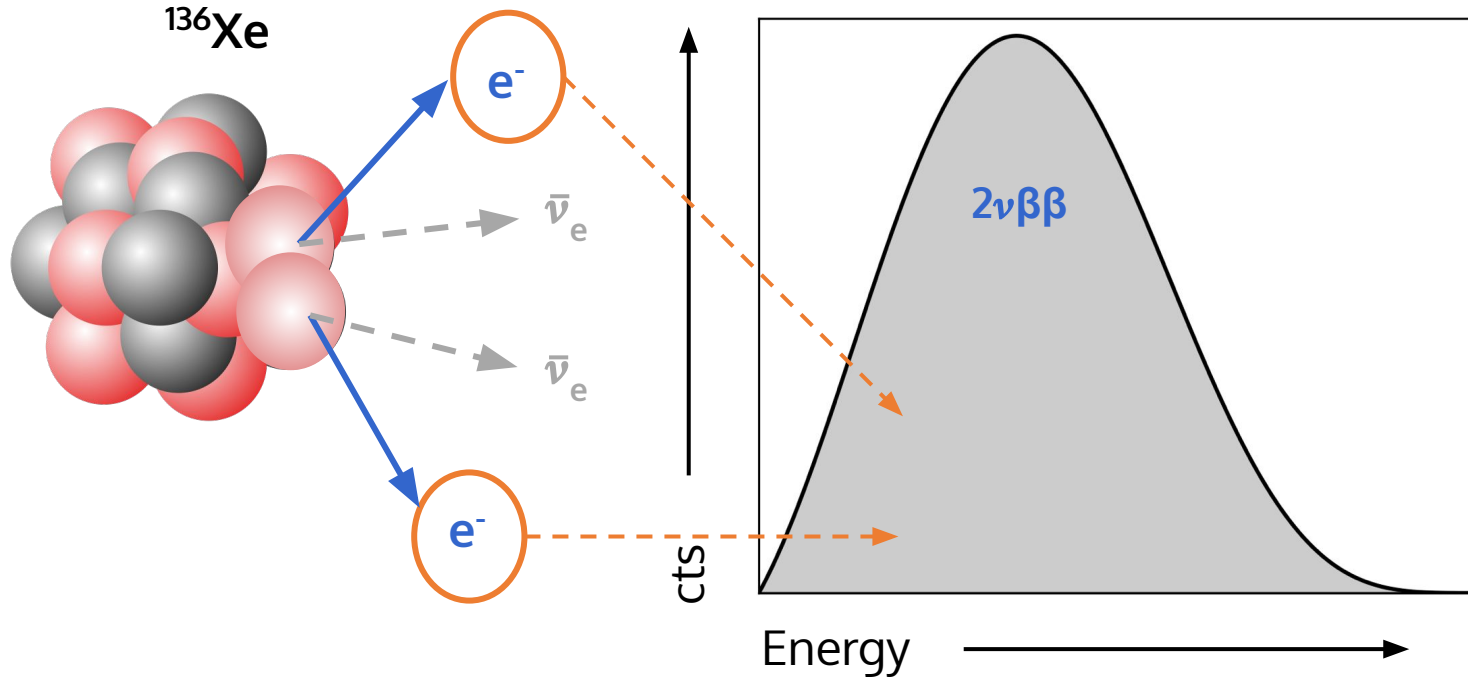

We can measure the energy of outgoing electrons!

Double beta decay ($2\nu\beta\beta$)

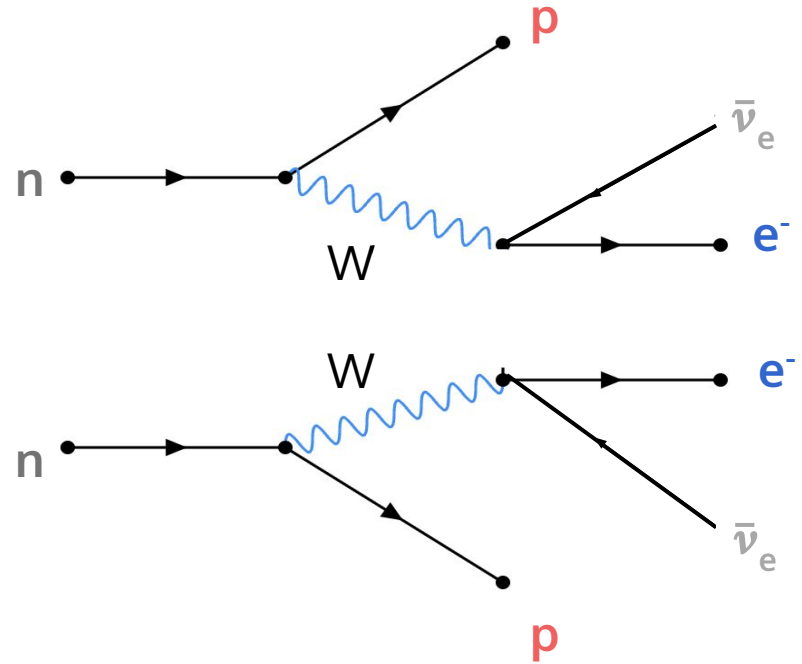
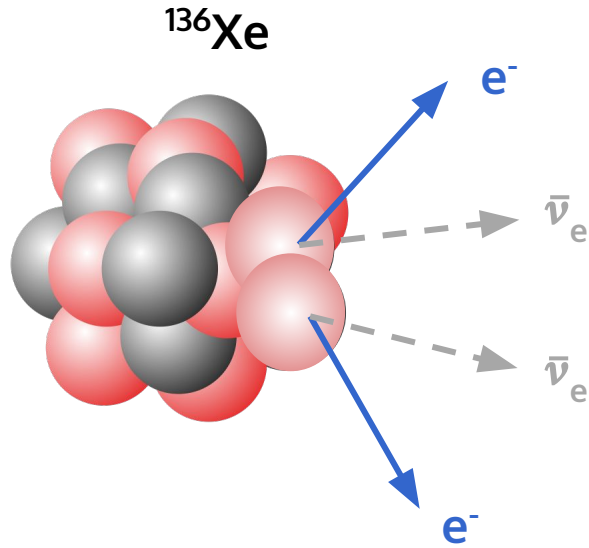

Double beta decay ($2\nu\beta\beta$)

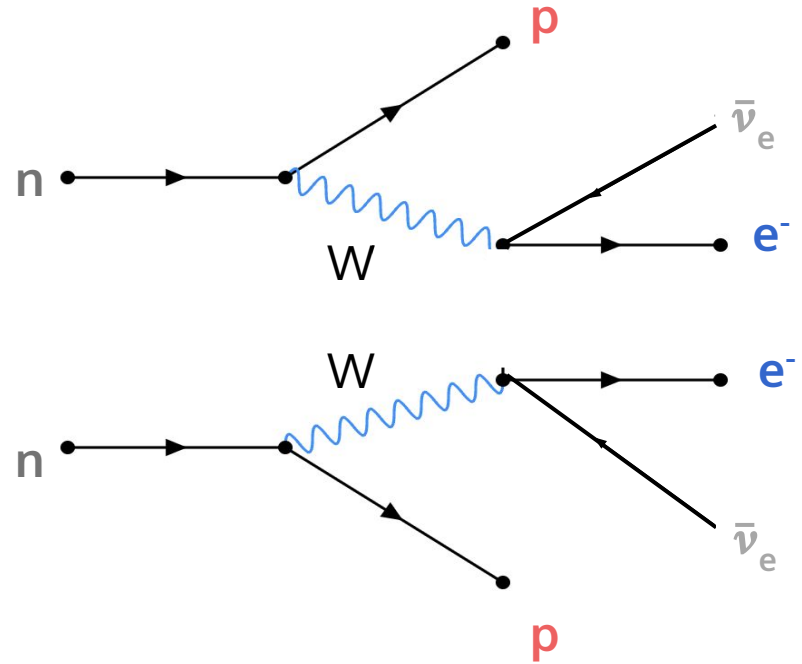
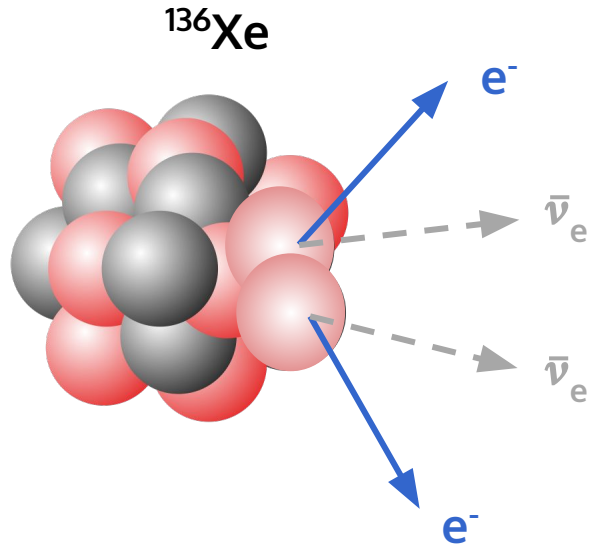

What if neutrinos were Majorana particles?

Neutrinoless double beta decay ($0\nu\beta\beta$)

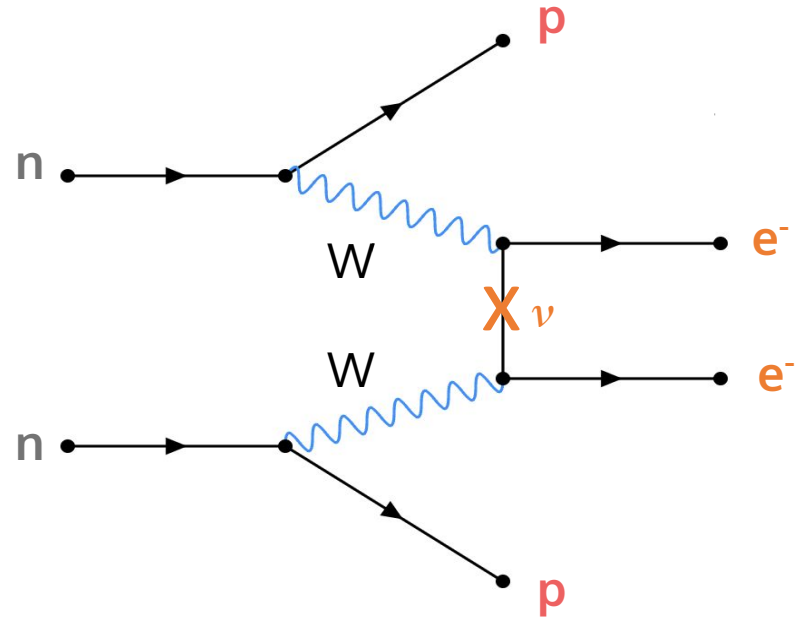
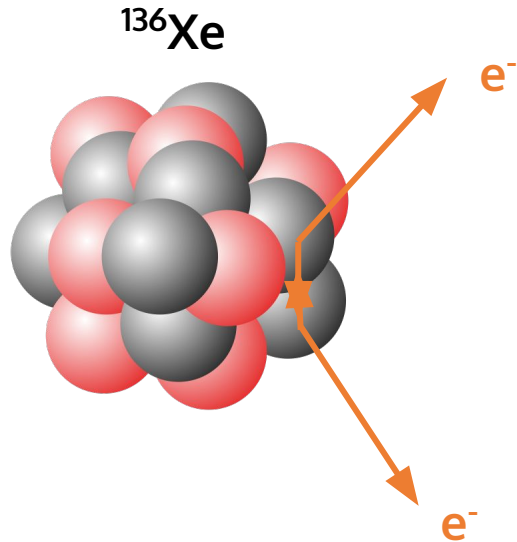

If neutrinos were Majorana particles $\rightarrow 0\nu\beta\beta$ is possible

Motivation to search for $0\nu\beta\beta$...

Particle physics community searching for physics beyond the Standard Model

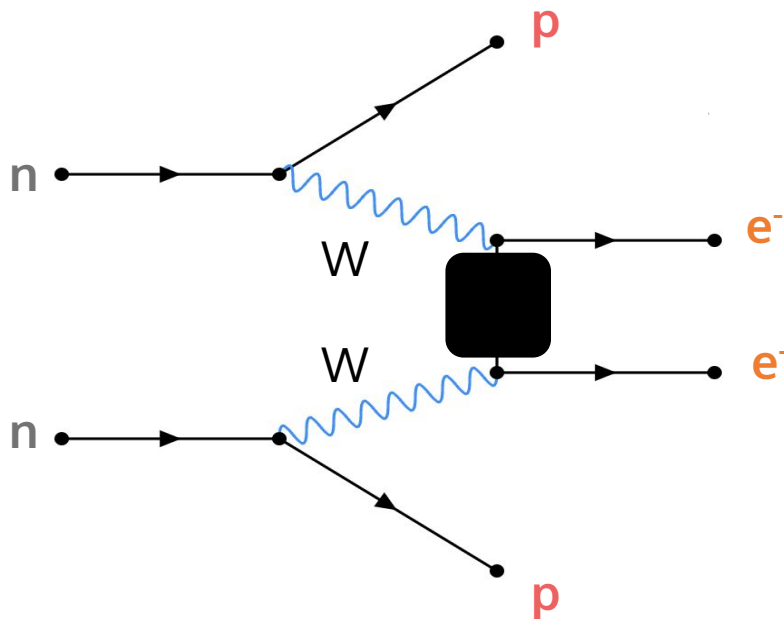

Schechter-Valle "**Black Box theorem**"
... regardless of what mechanism $0\nu\beta\beta$ proceeds by, $0\nu\beta\beta$ **always implies new physics.**

The Standard Model: Particles & Fields

	mass → $\approx 2.3 \text{ MeV}/c^2$	$\approx 1.275 \text{ GeV}/c^2$	$\approx 173.07 \text{ GeV}/c^2$	0	$\approx 126 \text{ GeV}/c^2$
charge →	$2/3$	$2/3$	$2/3$	0	0
spin →	$1/2$	$1/2$	$1/2$	1	0
	u up	c charm	t top	g gluon	H Higgs boson
QUARKS	$\approx 4.8 \text{ MeV}/c^2$	$\approx 95 \text{ MeV}/c^2$	$\approx 4.18 \text{ GeV}/c^2$	0	
	$-1/3$	$-1/3$	$-1/3$	0	
	$1/2$	$1/2$	$1/2$	1	
	d down	s strange	b bottom	γ photon	
	$0.511 \text{ MeV}/c^2$	$105.7 \text{ MeV}/c^2$	$1.777 \text{ GeV}/c^2$	$91.2 \text{ GeV}/c^2$	
	-1	-1	-1	0	
	$1/2$	$1/2$	$1/2$	1	
	e electron	μ muon	τ tau	Z Z boson	
LEPTONS	$< 2.2 \text{ eV}/c^2$	$< 0.17 \text{ MeV}/c^2$	$< 15.5 \text{ MeV}/c^2$	$80.4 \text{ GeV}/c^2$	
	0	0	0	± 1	
	$1/2$	$1/2$	$1/2$	1	
	ν_e electron neutrino	ν_μ muon neutrino	ν_τ tau neutrino	W W boson	
				GAUGE BOSONS	

The Standard Model: Lagrangian

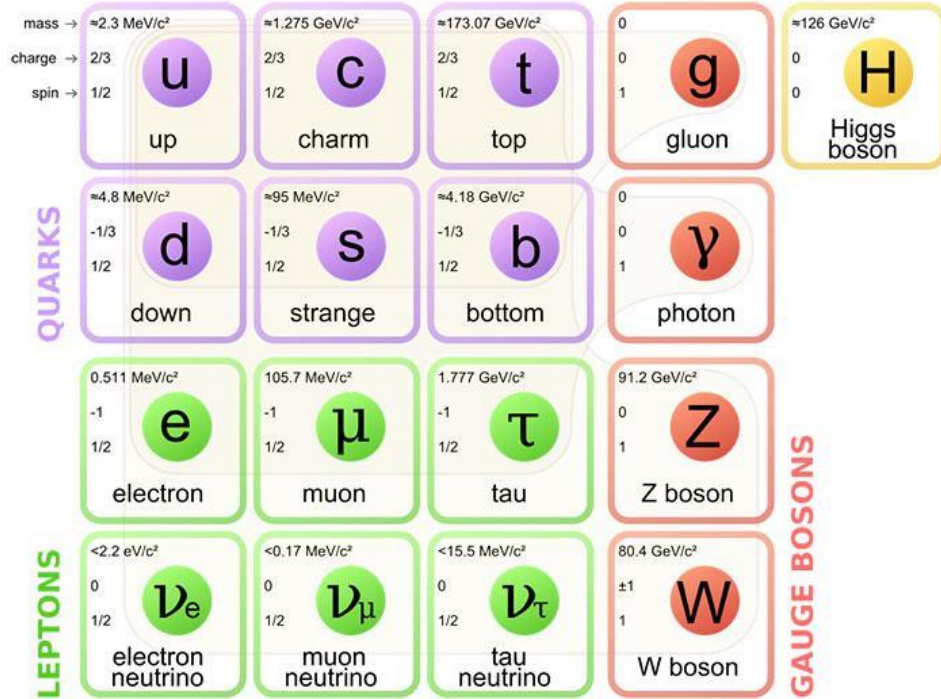

$$\begin{aligned}
 \mathcal{L}_{SM} = & -\frac{1}{2}\partial_\mu g_\nu^\alpha \partial_\nu g_\mu^\alpha - g_s f^{abc} \partial_\nu g_\mu^\alpha g_\nu^\beta g_\mu^\gamma - \frac{1}{4}g_s^2 f^{abc} f^{ade} g_\mu^\alpha g_\nu^\beta g_\mu^\gamma g_\nu^\delta + \\
 & \frac{1}{2}ig^2(\bar{q}^i \gamma^\mu q^j) W_\mu^k + C^a \partial^\mu C^a + g_s f^{abc} \partial_\mu C^a C^b q_\mu^c - \partial_\mu W_\nu^+ \partial_\mu W_\nu^- - \\
 & M^2 W_\mu^+ W_\mu^- - \frac{1}{2}\partial_\mu Z_\nu^0 \partial_\nu Z_\mu^0 - \frac{1}{2}M^2 Z_\nu^0 Z_\nu^0 - \frac{1}{2}\partial_\mu A_\nu \partial_\nu A_\mu - \frac{1}{2}\partial_\mu H \partial_\mu H - \\
 & \frac{1}{2}m_H^2 H^2 - \partial_\mu \epsilon^+ \partial_\nu \epsilon^- - M^2 \epsilon^+ \epsilon^- - \frac{1}{2}\partial_\mu \epsilon^0 \partial_\nu \epsilon^0 - \frac{1}{2}M^2 \epsilon^0 \epsilon^0 - \partial_\mu \frac{2M^2}{g} H + \\
 & \frac{2M}{g} H + \frac{1}{2}(H^2 + \epsilon^0 \epsilon^0 + 2\epsilon^+ \epsilon^-) + \frac{2M^2}{g} \alpha_h [-ig_{cb}(\partial_\mu Z_\nu^0 W_\mu^+ W_\nu^- - \\
 & W_\mu^+ W_\nu^-) - Z_\nu^0(W_\mu^+ \partial_\mu W_\nu^- - W_\mu^- \partial_\mu W_\nu^+) + Z_\nu^0(W_\mu^+ \partial_\mu W_\nu^- - \\
 & W_\mu^- \partial_\mu W_\nu^+)] - ig_{sw}(\partial_\mu A_\nu(W_\mu^+ W_\nu^- - W_\mu^- W_\nu^+) - A_\nu(W_\mu^+ \partial_\mu W_\nu^- - \\
 & W_\mu^- \partial_\mu W_\nu^+) + A_\nu(W_\mu^+ \partial_\mu W_\nu^- - W_\mu^- \partial_\mu W_\nu^+)) - \frac{1}{2}g^2 W_\mu^+ W_\nu^- W_\mu^- W_\nu^+ + \\
 & \frac{1}{2}g^2 W_\mu^- W_\nu^+ W_\mu^+ W_\nu^- + g^2 c_w^2 (Z_\mu^0 W_\mu^+ Z_\nu^0 W_\nu^- - Z_\mu^0 Z_\nu^0 W_\mu^+ W_\nu^-) + \\
 & g^2 s_w^2 (A_\mu W_\nu^+ A_\rho W_\rho^- - A_\rho A_\mu W_\nu^+ W_\rho^-) + g^2 s_w c_w [A_\nu Z_\mu^0 (W_\mu^+ W_\nu^- + \\
 & W_\mu^- W_\nu^+) - 2A_\nu Z_\mu^0 W_\mu^+ W_\nu^-] - g\alpha [H^3 + H\epsilon^0 \epsilon^0 + 2H\epsilon^+ \epsilon^-] - \\
 & \frac{1}{2}g^2 \alpha_h [H^4 + (\epsilon^0 + \epsilon^-)^2 + 4(\epsilon^0)^2 \epsilon^+ \epsilon^- + 4H^2 \epsilon^+ \epsilon^- + 2(\epsilon^0)^2 H^2] - \\
 & gM W_\mu^+ W_\nu^- H - \frac{1}{2}g\frac{M}{c_w} Z_\mu^0 Z_\nu^0 H - \frac{1}{2}ig[W_\mu^+ (\epsilon^0 \partial_\nu \epsilon^- - \epsilon^- \partial_\nu \epsilon^0) - \\
 & W_\mu^- (\epsilon^0 \partial_\nu \epsilon^+ - \epsilon^+ \partial_\nu \epsilon^0)] + \frac{1}{2}ig[W_\mu^+ (H \partial_\nu \epsilon^- - \epsilon^- \partial_\nu H) - W_\mu^- (H \partial_\nu \epsilon^+ - \\
 & \epsilon^+ \partial_\nu H)] + \frac{1}{2}ig\frac{1}{c_w} Z_\mu^0 (H \partial_\nu \epsilon^0 - \epsilon^0 \partial_\nu H) - ig\frac{M}{c_w} Z_\mu^0 (W_\mu^+ \epsilon^- - W_\mu^- \epsilon^+) + \\
 & ig_{sw} M A_\nu (W_\mu^+ \epsilon^- - W_\mu^- \epsilon^+) - ig\frac{1}{c_w} Z_\mu^0 (\epsilon^+ \partial_\nu \epsilon^- - \epsilon^- \partial_\nu \epsilon^+) + \\
 & ig_{sw} A_\nu (\epsilon^+ \partial_\nu \epsilon^- - \epsilon^- \partial_\nu \epsilon^+) - \frac{1}{2}g^2 W_\mu^+ W_\nu^- W_\mu^+ W_\nu^- + (E^0)^2 + 2E^+ E^- - \\
 & \frac{1}{2}g^2 \frac{M^2}{c_w} Z_\mu^0 Z_\nu^0 + (E^0)^2 + 2(E^+)^2 + 2(E^-)^2 - \frac{1}{2}g^2 \frac{M^2}{c_w} Z_\mu^0 Z_\nu^0 + \\
 & W_\mu^+ \epsilon^- + \frac{1}{2}ig\frac{M}{c_w} Z_\mu^0 (W_\mu^+ \epsilon^- - W_\mu^- \epsilon^+) - g^2 \frac{M^2}{c_w} (2c_w^2 - 1) Z_\mu^0 Z_\nu^0 \epsilon^- - \\
 & g^2 s_w^2 c_w (\epsilon^- \partial_\nu \epsilon^+ - \epsilon^+ \partial_\nu \epsilon^-) + m_h^2 (\epsilon^+ \epsilon^- + \frac{1}{2}(\epsilon^0)^2) + \\
 & \frac{1}{2}g^2 \frac{M^2}{c_w} Z_\mu^0 Z_\nu^0 + ig_{sw} A_\nu [-(\epsilon^+ \gamma^\mu \epsilon^-) + \frac{1}{2}(\epsilon^0 \gamma^\mu \epsilon^0) - \frac{1}{2}(\epsilon^+ \gamma^\mu \epsilon^+) + \\
 & \frac{1}{2}(\epsilon^- \gamma^\mu \epsilon^-)] + (\epsilon^+ \gamma^\mu \epsilon^+) + (\epsilon^0 \gamma^\mu (4s_w^2 - 1 - \gamma^5) \epsilon^0) + (\epsilon^+ \gamma^\mu (\frac{1}{2}g_s^2 - \\
 & 1 - \gamma^5) \epsilon^+) + (\epsilon^+ \gamma^\mu (1 - \frac{1}{2}g_s^2 - \gamma^5) \epsilon^0) + \frac{ig_{sw}}{2c_w} W_\mu^+ (\epsilon^+ \gamma^\mu (1 + \gamma^5) \epsilon^+) + \\
 & (\epsilon^+ \gamma^\mu (1 + \gamma^5) C_{3e} d_f^j) + \frac{ig_{sw}}{2c_w} W_\mu^- [(\epsilon^- \gamma^\mu (1 + \gamma^5) \nu^+) + (\epsilon^- \gamma^\mu C_{3e}^j \nu^+ (1 + \\
 & \gamma^5) u_j^j)] + \frac{ig_{sw}}{2c_w} \frac{m_W}{\sqrt{2}} [-\epsilon^+ (\nu^+ (1 - \gamma^5) \epsilon^+) + \epsilon^- (\epsilon^- (1 + \gamma^5) \nu^-) - \\
 & \frac{g}{\sqrt{2}} \frac{M}{W} [H(\epsilon^+ \nu^+) + i\epsilon^0 (\epsilon^+ \gamma^5 \epsilon^+) + \frac{ig_{sw}}{2M\sqrt{2}} \epsilon^+ [-m_h^2 (\epsilon^+ \gamma^5) C_{3e} (1 - \gamma^5) d_f^j + \\
 & m_h^2 (\epsilon^+ \gamma^5) C_{3e} (1 + \gamma^5) d_f^j] + \frac{ig_{sw}}{2M\sqrt{2}} \epsilon^- [m_h^2 (\epsilon^- \gamma^5) C_{3e}^j (1 + \gamma^5) u_j^j - m_h^2 (\epsilon^- \gamma^5) C_{3e}^j (1 - \\
 & \gamma^5) u_j^j] - \frac{g}{\sqrt{2}} \frac{M}{W} H (u_j^j \nu_j^j) - \frac{g}{\sqrt{2}} \frac{M}{W} H (d_j^j \nu_j^j) + \frac{ig_{sw}}{2M\sqrt{2}} \epsilon^0 (u_j^j \nu_j^j u_j^j - \\
 & \frac{ig_{sw}}{2M\sqrt{2}} \epsilon^0 (\epsilon^+ \gamma^5 d_j^j) + \bar{X}^+ (\partial^2 - M^2) X^+ + \bar{X}^- (\partial^2 - M^2) X^- + \bar{X}^0 (\partial^2 - \\
 & \frac{M^2}{c_w^2}) X^0 + Y \partial^2 Y + ig_{cb} W_\mu^+ (\partial_\mu X^0 X^- - \partial_\mu X^+ X^0) + ig_{sw} W_\mu^+ (\partial_\mu Y X^- - \\
 & \partial_\mu X^+ Y) + ig_{cb} W_\mu^- (\partial_\mu X^- X^0 - \partial_\mu X^0 X^+) + ig_{sw} W_\mu^- (\partial_\mu X^- Y - \\
 & \partial_\mu Y X^+) + ig_{cb} Z_\mu^0 (\partial_\mu X^+ X^- - \partial_\mu X^- X^+) + ig_{sw} A_\mu (\partial_\mu X^+ X^- + \\
 & \partial_\mu X^- X^+) - \frac{1}{2}gM[\bar{X}^+ X^+ H + \bar{X}^- X^- H + \frac{1}{c_w} \bar{X}^0 X^0 H] + \\
 & \frac{1}{2}igM[\bar{X}^+ X^0 \epsilon^+ - \bar{X}^- X^0 \epsilon^-] + \frac{1}{2}igM[\bar{X}^0 X^- \epsilon^+ - \bar{X}^0 X^+ \epsilon^-] + \\
 & \frac{1}{2}igM[\bar{X}^+ X^- \epsilon^+ - \bar{X}^0 X^+ \epsilon^-] + \frac{1}{2}igM[\bar{X}^+ X^- \epsilon^0 - \bar{X}^- X^+ \epsilon^0]
 \end{aligned}$$

The Standard Model: Symmetries

$$SU(3) \times SU(2)_L \times U(1)_Y$$

mass →	≈2.3 MeV/c ²	≈1.275 GeV/c ²	≈173.07 GeV/c ²	0	≈126 GeV/c ²
charge →	2/3	2/3	2/3	0	0
spin →	1/2	1/2	1/2	1	0
	u up	c charm	t top	g gluon	H Higgs boson
QUARKS					
	≈4.8 MeV/c ²	≈95 MeV/c ²	≈4.18 GeV/c ²	0	
	-1/3	-1/3	-1/3	0	
	1/2	1/2	1/2	1	
	d down	s strange	b bottom	γ photon	
	0.511 MeV/c ²	105.7 MeV/c ²	1.777 GeV/c ²	91.2 GeV/c ²	
	-1	-1	-1	0	
	1/2	1/2	1/2	1	
	e electron	μ muon	τ tau	Z Z boson	
LEPTONS					
	<2.2 eV/c ²	<0.17 MeV/c ²	<15.5 MeV/c ²	80.4 GeV/c ²	
	0	0	0	±1	
	1/2	1/2	1/2	1	
	ν_e electron neutrino	ν_μ muon neutrino	ν_τ tau neutrino	W W boson	
					GAUGE BOSONS

$$\mathcal{L}_{SM} = -\frac{1}{4} \partial_\mu g_\nu^a \partial_\mu g_\nu^a - g_s f^{abc} \partial_\mu g_\nu^a \partial_\mu g_\nu^b g_\nu^c - \frac{1}{4} g_2^2 f^{abc} \partial_\mu W_\nu^a \partial_\mu W_\nu^b g_\nu^c + \frac{1}{2} g_1^2 (\partial_\mu \theta^a \partial_\mu \theta^a) + C^a \partial_\mu C^a + g_1 f^{abc} \partial_\mu C^a \partial_\mu C^b g_\nu^c - \partial_\mu W_\nu^+ \partial_\mu W_\nu^- - M^2 W_\mu^+ W_\mu^- - \frac{1}{2} \partial_\mu Z_\nu^0 \partial_\mu Z_\nu^0 - \frac{1}{2} M^2 Z_\mu^0 Z_\mu^0 - \frac{1}{2} \partial_\mu A_\nu \partial_\mu A_\nu - \frac{1}{2} \partial_\mu H \partial_\mu H - \frac{1}{2} m_H^2 H^2 - \partial_\mu \epsilon^+ \partial_\mu \epsilon^- - M^2 \epsilon^+ \epsilon^- - \frac{1}{2} \partial_\mu \epsilon^0 \partial_\mu \epsilon^0 - \frac{1}{2} M^2 \epsilon^0 \epsilon^0 - \beta_h \frac{2M^2}{\Lambda^2} + \frac{2M}{g} H + \frac{1}{2} (H^2 + \epsilon^0 \epsilon^0 + 2\epsilon^+ \epsilon^-) + \frac{2M^4}{\Lambda^2} \alpha_h - ig_{cw} [\partial_\mu Z_\nu^0 (W_\mu^+ W_\nu^- - W_\mu^- W_\nu^+) - Z_\nu^0 (W_\mu^+ \partial_\mu W_\nu^- - W_\mu^- \partial_\mu W_\nu^+) + Z_\nu^0 (\partial_\mu W_\nu^+ - W_\mu^+ \partial_\nu) - ig_{sw} (\partial_\mu A_\nu (W_\mu^+ W_\nu^- - W_\mu^- W_\nu^+) - A_\nu (W_\mu^+ \partial_\mu W_\nu^- - W_\mu^- \partial_\mu W_\nu^+) + A_\nu (W_\mu^+ \partial_\nu W_\mu^- - W_\mu^- \partial_\nu W_\mu^+) - \frac{1}{2} g^2 W_\mu^+ W_\nu^- W_\mu^+ W_\nu^- + \frac{1}{2} g^2 W_\mu^- W_\nu^+ W_\mu^- W_\nu^+ + g^2 c_w^2 (Z_\mu^0 W_\nu^+ Z_\mu^0 W_\nu^- - Z_\mu^0 W_\nu^+ W_\mu^- + g^2 s_w^2 (A_\mu W_\nu^+ A_\mu W_\nu^- - A_\mu A_\nu W_\mu^+ W_\nu^-) + g^2 s_w c_w (A_\mu Z_\mu^0 (W_\mu^+ W_\nu^- - W_\mu^- W_\nu^+) - 2A_\mu Z_\mu^0 W_\nu^+ W_\nu^-) - g \alpha (\partial_\mu H^2 + H \partial_\mu \epsilon^0 + 2H \epsilon^+ \epsilon^-) - \frac{1}{2} g^2 \alpha_h (H^4 + (\epsilon^0)^4 + 4(\epsilon^+ \epsilon^-)^2 + 4(\epsilon^0)^2 \epsilon^+ \epsilon^- + 4H \epsilon^+ \epsilon^- + 2(\epsilon^0)^2 H^2) - g M W_\mu^+ W_\nu^- H - \frac{1}{2} g \frac{M}{\Lambda^2} Z_\mu^0 Z_\nu^0 H - \frac{1}{2} ig (W_\mu^+ \epsilon^0 \partial_\nu \epsilon^- - \epsilon^- \partial_\nu \epsilon^0) - W_\mu^- (\epsilon^0 \partial_\nu \epsilon^+ - \epsilon^+ \partial_\nu \epsilon^0)] + \frac{1}{2} ig (W_\mu^+ (H \partial_\nu \epsilon^- - \epsilon^- \partial_\nu H) - W_\mu^- (H \partial_\nu \epsilon^+ - \epsilon^+ \partial_\nu H)) + \frac{1}{2} ig \frac{1}{\Lambda^2} (Z_\mu^0 (H \partial_\nu \epsilon^0 - \epsilon^0 \partial_\nu H) - ig_{cw} M Z_\mu^0 (W_\mu^+ \epsilon^- - W_\mu^- \epsilon^+)) + ig_{sw} M A_\mu (W_\mu^+ \epsilon^- - W_\mu^- \epsilon^+) - ig \frac{1}{\Lambda^2} Z_\mu^0 (\epsilon^+ \partial_\nu \epsilon^- - \epsilon^- \partial_\nu \epsilon^+) + ig_{sw} A_\mu (\epsilon^+ \partial_\nu \epsilon^- - \epsilon^- \partial_\nu \epsilon^+) - \frac{1}{2} g^2 W_\mu^+ W_\nu^+ (H^2 + \epsilon^0)^2 + 2\epsilon^+ \epsilon^- - \frac{1}{2} g^2 Z_\mu^0 (H^2 + \epsilon^0)^2 + 2(2\epsilon^+ \epsilon^-) - \frac{1}{2} g^2 c_w^2 (W_\mu^+ \epsilon^- - W_\mu^- \epsilon^+)^2 + \frac{1}{2} g^2 s_w^2 (A_\mu (W_\mu^+ \epsilon^- - W_\mu^- \epsilon^+))^2 - g^2 \frac{1}{\Lambda^2} (2\epsilon^+ \epsilon^-)^2 - g^2 s_w^2 (W_\mu^+ \epsilon^- - \epsilon^- \partial_\nu \epsilon^0 + m_\epsilon^2 \epsilon^+ \epsilon^-) + m_\epsilon^2 (\epsilon^+ \epsilon^-) + \frac{1}{2} (g^2 \gamma^0 \gamma^0) u_\epsilon^2 - \frac{1}{2} (g^2 \gamma^0 \gamma^0) u_\epsilon^2 + \frac{1}{2} ig_{sw} A_\mu [-(\epsilon^+ \gamma^0 \epsilon^-) + \frac{1}{2} (\epsilon^+ \gamma^0 \epsilon^-) - \frac{1}{2} (g^2 \gamma^0 \gamma^0) u_\epsilon^2] + \frac{1}{2} c_w Z_\mu^0 (\nu^+ \gamma^\mu (1 + \gamma^5) \nu^+) + (\epsilon^+ \gamma^\mu (4s_w^2 - 1 - \gamma^5) \epsilon^-) + (g^2 \gamma^\mu (\frac{2}{3} s_w^2 - 1 - \gamma^5) u_\epsilon^2) + (g^2 \gamma^\mu (1 - \frac{2}{3} s_w^2 - \gamma^5) d_\epsilon^2) + \frac{ig_{sw}}{2\sqrt{2}} W_\mu^+ (\nu^+ \gamma^\mu (1 + \gamma^5) \epsilon^+) + (g^2 \gamma^\mu (1 + \gamma^5) C_{\lambda\epsilon} d_\epsilon^2) + \frac{ig_{sw}}{2\sqrt{2}} W_\mu^- [(\epsilon^+ \gamma^\mu (1 + \gamma^5) \nu^+) + (g^2 C_{\lambda\epsilon}^+ \gamma^\mu (1 + \gamma^5) u_\epsilon^2)] + \frac{ig_{sw}}{2\sqrt{2}} W_\mu^- [-\epsilon^+ (\nu^+ (1 - \gamma^5) \epsilon^-) + \epsilon^- (\epsilon^+ (1 + \gamma^5) \nu^+)] - \frac{g}{2} \frac{M}{\Lambda^2} H (\epsilon^+ \epsilon^-) + i\epsilon^0 (\epsilon^+ \gamma^5 \epsilon^-) + \frac{ig_{sw}}{2\sqrt{2}} \epsilon^+ [-m_\epsilon^2 (g^2 C_{\lambda\epsilon} (1 - \gamma^5) d_\epsilon^2) + m_\epsilon^2 (g^2 C_{\lambda\epsilon} (1 + \gamma^5) d_\epsilon^2) + \frac{ig_{sw}}{2\sqrt{2}} (d_\epsilon^2 C_{\lambda\epsilon}^+ (1 + \gamma^5) u_\epsilon^2) - m_\epsilon^2 (d_\epsilon^2 C_{\lambda\epsilon}^+ (1 - \gamma^5) u_\epsilon^2)] - \frac{g}{2} \frac{M}{\Lambda^2} H (u_\epsilon^2 u_\epsilon^2) - \frac{g}{2} \frac{M}{\Lambda^2} H (d_\epsilon^2 d_\epsilon^2) + \frac{ig_{sw}}{2\sqrt{2}} \epsilon^0 (u_\epsilon^2 \gamma^5 u_\epsilon^2) - \frac{ig_{sw}}{2\sqrt{2}} \epsilon^0 (d_\epsilon^2 \gamma^5 d_\epsilon^2) + \bar{X} + (\partial^2 - M^2) X^+ + \bar{X} - (\partial^2 - M^2) X^- + \bar{X}^0 (\partial^2 - \frac{M^2}{c_w^2}) X^0 + Y \partial^2 Y + ig_{cw} W_\mu^+ (\partial_\mu X^0 X^- - \partial_\mu X^+ X^0) + ig_{sw} W_\mu^+ (\partial_\mu Y X^- - \partial_\mu X^+ Y) + ig_{cw} W_\mu^- (\partial_\mu X^- X^0 - \partial_\mu X^0 X^+) + ig_{sw} W_\mu^- (\partial_\mu X^- Y - \partial_\mu Y X^+) + ig_{cw} Z_\mu^0 (\partial_\mu X^+ X^- - \partial_\mu X^- X^+) + ig_{sw} A_\mu (\partial_\mu X^+ X^- - \partial_\mu X^- X^+) - \frac{1}{2} g M [\bar{X}^+ X^+ H + \bar{X}^- X^- H + \frac{1}{c_w} \bar{X}^0 X^0 H] + \frac{1-2c_w}{2c_w} ig M [\bar{X}^+ X^0 \epsilon^+ - \bar{X}^- X^0 \epsilon^-] + \frac{1}{2c_w} ig M [\bar{X}^0 X^- \epsilon^+ - \bar{X}^0 X^+ \epsilon^-] + \frac{1-2c_w}{2c_w} ig M s_w [\bar{X}^+ X^- \epsilon^+ - \bar{X}^0 X^+ \epsilon^-] + \frac{1}{2} ig M [\bar{X}^+ X^- \epsilon^0 - \bar{X}^- X^+ \epsilon^0]$$

Standard Model: Electroweak Symmetry

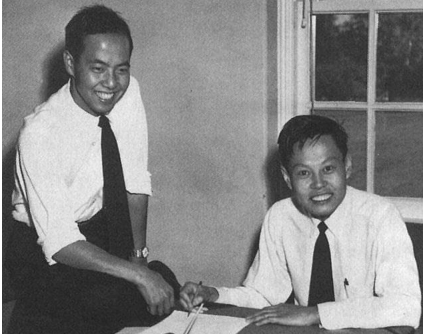

$$SU(3) \times SU(2)_L \times U(1)_Y$$

Only left handed fields feel the weak force;
It is a parity-violating chiral theory

Symmetries of a Lagrangian

Conservation Laws



Symmetries of a Lagrangian

Conservation Laws



... there is no symmetry in the SM Lagrangian protecting lepton number!

The Higgs and Mass Generation

Nobel Prize in Physics 1979



Photo from the Nobel Foundation archive: Sheldon Lee Glashow, Abdus Salam, Steven Weinberg

credit: [Royal Swedish Academy of Sciences](#)

Nobel Prize in Physics 1999



Martinus Veltman, Professor Emeritus at the University of Michigan, Ann Arbor, USA, formerly at the University of Utrecht, Utrecht, the Netherlands. Gerardus 't Hooft, Professor at the University of Utrecht, Utrecht, the Netherlands.

credit: [Royal Swedish Academy of Sciences](#)

Nobel Prize in Physics 2013

credit: [Bob the Bolder](#) & [Alexander Mahmoud](#)

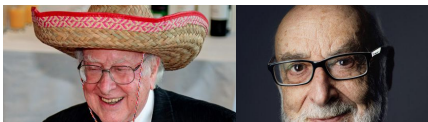

Peter Higgs, Francois Englert

$$SU(3) \times SU(2)_L \times U(1)_Y$$

(lower energies)
electroweak force breaks down to
electromagnetism + weak force

$$SU(3) \times U(1)_{EM}$$

The Higgs and Mass Generation

Nobel Prize in Physics 1979



Photo from the Nobel Foundation archive: Sheldon Lee Glashow, Abdus Salam, Steven Weinberg

credit [Royal Swedish Academy of Sciences](#)

Nobel Prize in Physics 1999



Martinus Veltman, Professor Emeritus at the University of Michigan, Ann Arbor, USA, formerly at the University of Utrecht, Utrecht, the Netherlands. Gerardus 't Hooft, Professor at the University of Utrecht, Utrecht, the Netherlands.

credit [Royal Swedish Academy of Sciences](#)

Nobel Prize in Physics 2013

credit: [Bob the Bolder](#) & [Alexander Mahmoud](#)



Peter Higgs, Francois Englert

$$SU(3) \times SU(2)_L \times U(1)_Y$$

(lower energies)
electroweak force breaks down to
electromagnetism + weak force

$$SU(3) \times U(1)_{EM}$$

“We can glue the left- and right-chiral fields together and break the electroweak symmetry via **the Higgs mechanism...**”

“ ... allowing fermions to **acquire a mass**”

... and neutrinos are massless? (c. 1957-1998)

- Kinematically, neutrinos were seemingly massless
- All neutrinos observed to be left-handed, all anti-neutrinos observed to be right-handed*

No need for RH- ν \rightarrow no need for additional degrees of freedom

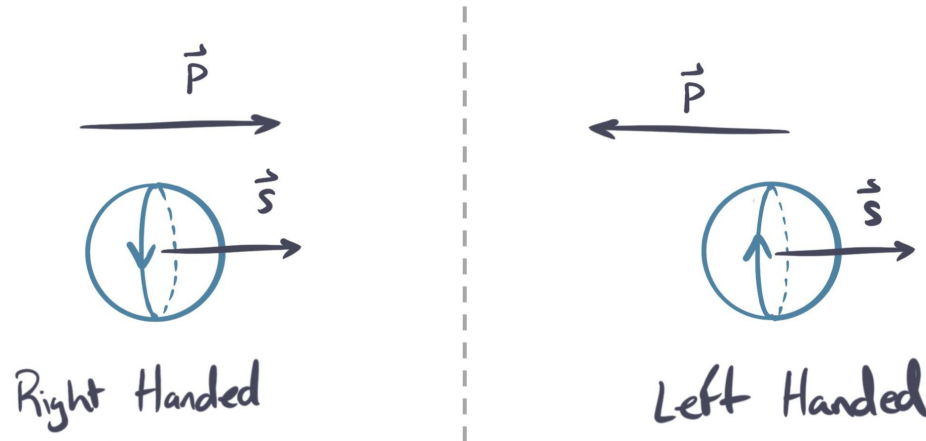

* See: "Goldhaber Experiment"

But neutrinos must have mass because they *~OSCILLATE~*

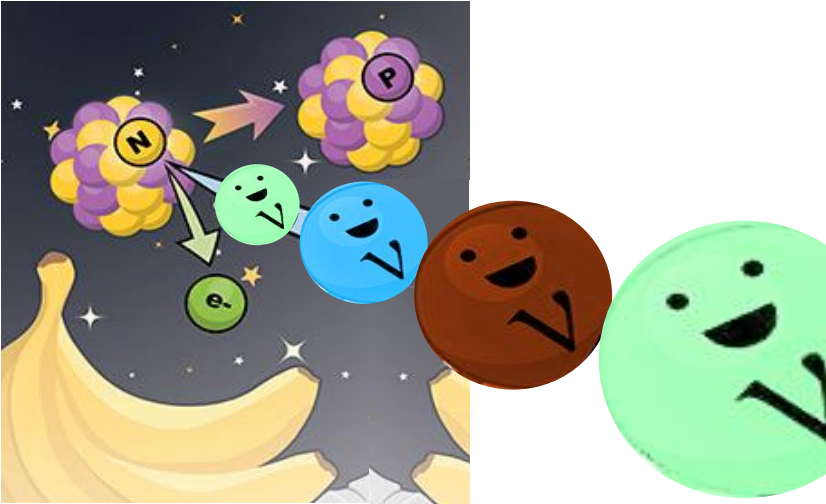
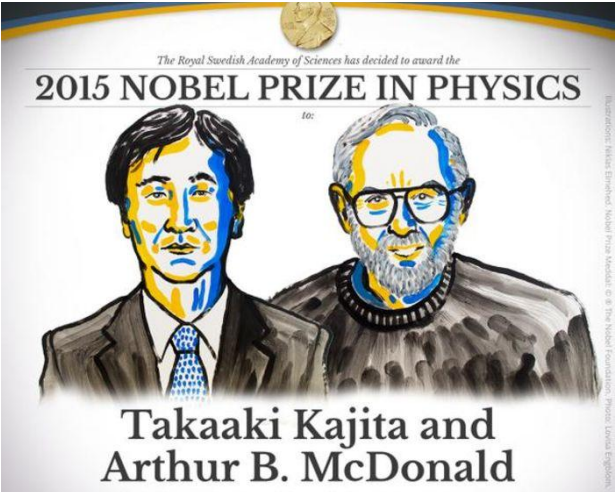

T. Bowman, BNL

LEPTONS	0.511 MeV/c ² -1 1/2 e electron	105.7 MeV/c ² -1 1/2 μ muon	1.777 GeV/c ² -1 1/2 τ tau
	<2.2 eV/c ² 0 1/2 ν_e electron neutrino	<0.17 MeV/c ² 0 1/2 ν_μ muon neutrino	<15.5 MeV/c ² 0 1/2 ν_τ tau neutrino

How are neutrinos (ν) massive... but so much less massive than everything else?

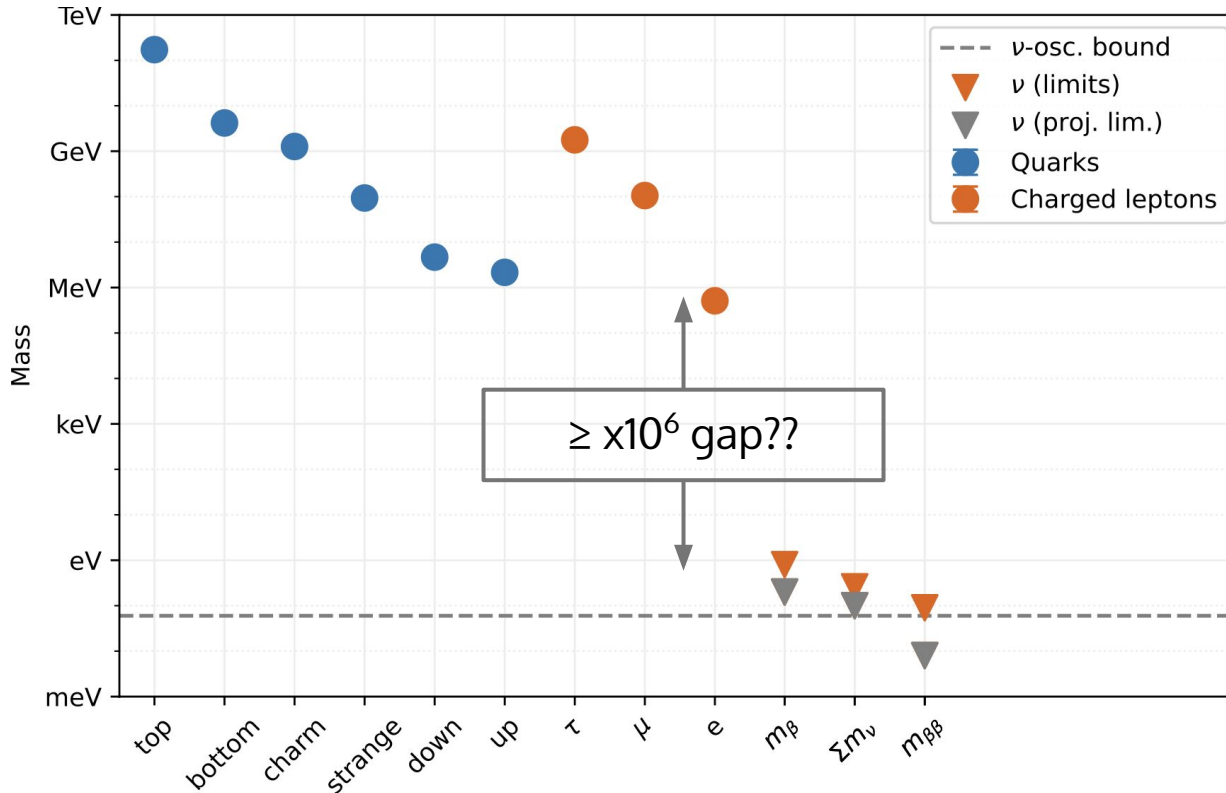

Solutions to the neutrino mass problem

1. **Add RH- ν fields** to the Standard Model & **tune Higgs coupling to be tiny** for mass terms in the Lagrangian ($Y_c H \nu_R \nu_L$ terms)

(purely Dirac particles)

2. Keep Higgs coupling ~ 1 for ν compared to other leptons, allow for a see^{saw}

(Majorana particles)

Do Majorana neutrinos help us?

- **Lose two degrees of freedom** in the SM for Majorana neutrinos
- Weinberg operator:
- Seesaw mechanisms:
- Matter vs Antimatter?

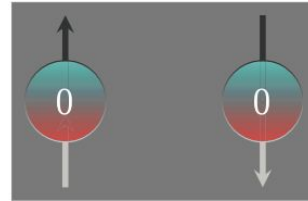
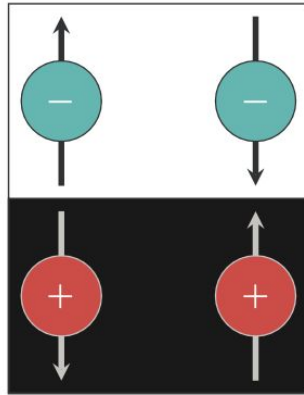

Credit: The State of the Art of Neutrino Physics

Do Majorana neutrinos help us?

- Lose two degrees of freedom in the SM for Majorana neutrinos
- **Weinberg operator**: there is one unique way you can construct a next-leading-order operator in the SM using only SM particles. It **naturally produces Majorana neutrinos, and violates Lepton number**.
- Seesaw mechanisms:
- Matter vs Antimatter?

$$SU(3) \times SU(2)_L \times U(1)_Y$$

$$L_{\text{Weinberg}} = Y_c / \Lambda \ L_L \Phi \Phi^\dagger L_L$$

Λ : cutoff energy scale, need new physics

Do Majorana neutrinos help us?

- Lose two degrees of freedom in the SM for Majorana neutrinos
- Weinberg operator
- **Seesaw mechanisms**: having masses of neutrinos be both Dirac and Majorana neutrinos give you a natural “seesaw” forcing neutrino masses to be small, even though the Higgs’ vacuum expectation value is the same for all particles
- Matter vs Antimatter?



Do Majorana neutrinos help us?

- Lose two degrees of freedom in the SM for Majorana neutrinos
- Weinberg operator
- Seesaw mechanisms
- **Matter vs Antimatter?** Maybe $m_{\nu R}$ associated with Λ and are *really heavy*?
 - Possible explanation for the matter / antimatter asymmetry!! (leptogenesis)

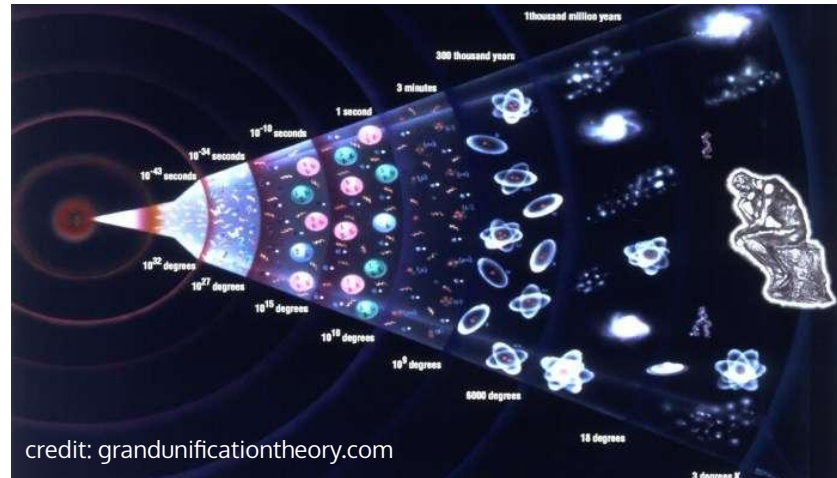

Majorana neutrinos naturally give us:

lepton number non-conservation

(Weinberg operator & Schechter-Valle "theorem")

naturally small neutrino masses

(via see^{saw} mechanisms)

pathway to matter-antimatter asymmetry

("leptogenesis")

But how can we test these ideas?

- Lose two degrees of freedom in the SM for Majorana neutrinos
- Weinberg operator
- Seesaw mechanisms
- Matter vs Antimatter?

But how can we test these ideas?

- Lose two degrees of freedom in the SM for Majorana neutrinos
- Weinberg operator
- Seesaw mechanisms
- Matter vs Antimatter?

NB: if neutrinos have masses $\sim \text{meV}$, then Λ will be $\sim 10^{12}$ TeV

LHC \sqrt{s} energy is ~ 13 TeV: **we should not expect to see *this* new physics at colliders in our lifetime!***

*FCC-hh \sqrt{s} energy is ~ 100 TeV

Exploring Majorana neutrinos

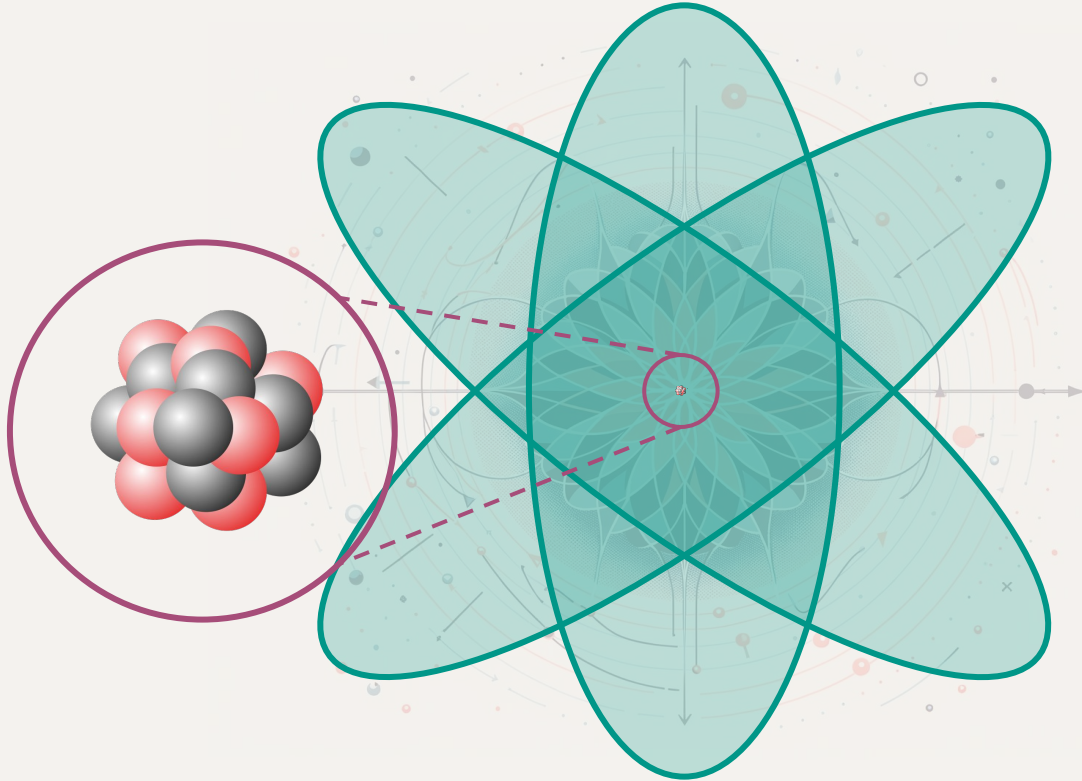

through the lens of an atomic nucleus

Double beta decay ($2\nu\beta\beta$)

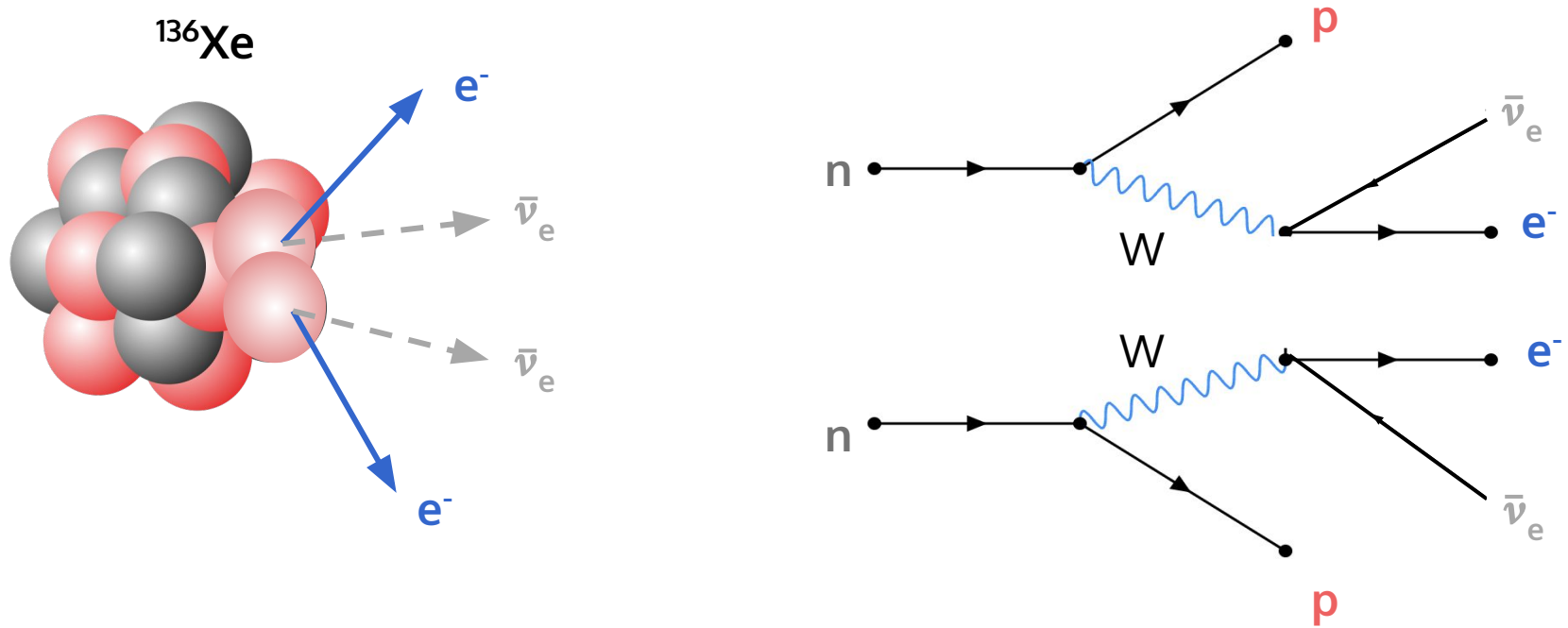

What if neutrinos were Majorana particles?

$2\nu\beta\beta$ vs $0\nu\beta\beta$

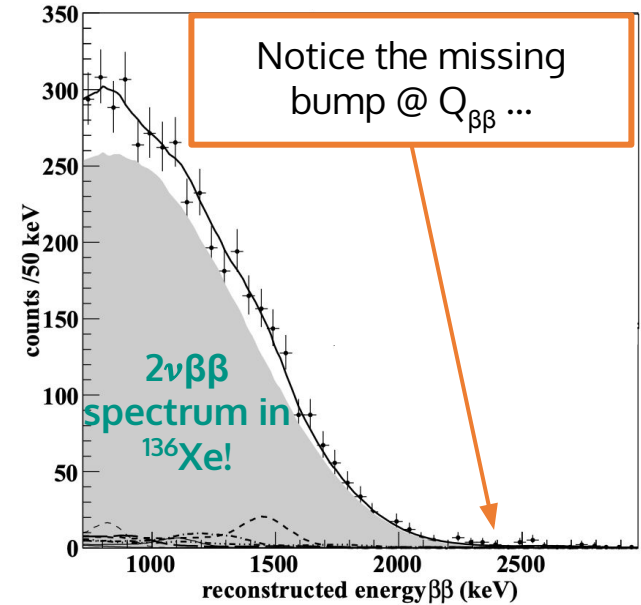
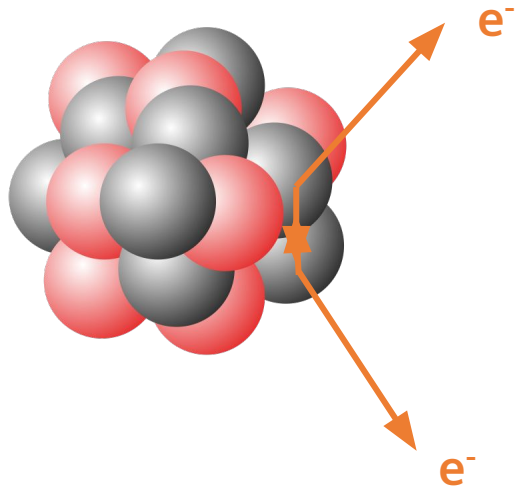

Adapted from: [Ackerman, N., et al. "Observation of two-neutrino double-beta decay in Xe-136 with the EXO-200 Detector." *Phys Rev Lett* 107.21 \(2011\): 212501.](#)

Does $0\nu\beta\beta$ exist?

The nEXO $0\nu\beta\beta$ Experiment

- 5-tonnes of LXe is **enriched to 90%** in the target isotope, ^{136}Xe
- LXe in a single-phase liquid xenon Time Projection Chamber (LXe TPC)
- Surrounded by a large water tank for radioactive shielding and **muon tagging**

[Adhikari, Govinda, et al. "nEXO: neutrinoless double beta decay search beyond 1028 year half-life sensitivity." *Journal of Physics G: Nuclear and Particle Physics* 49.1 \(2021\): 015104.](#)

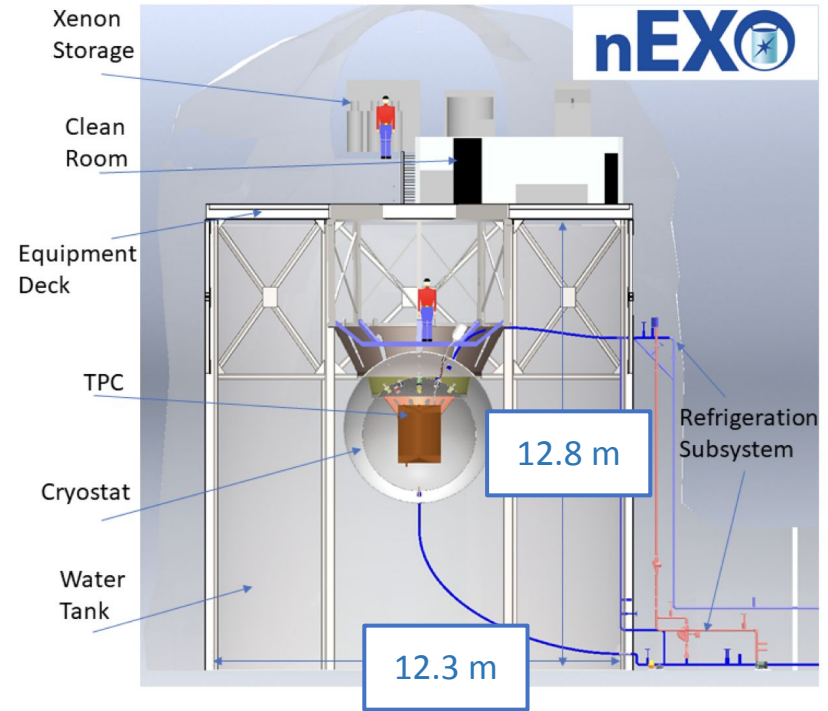

The nEXO $0\nu\beta\beta$ Experiment

- 5-tonnes of LXe is enriched to 90% in the target isotope, ^{136}Xe
- LXe in a single-phase liquid xenon Time Projection Chamber (LXe TPC)
- Surrounded by a large water tank for radioactive shielding and muon tagging

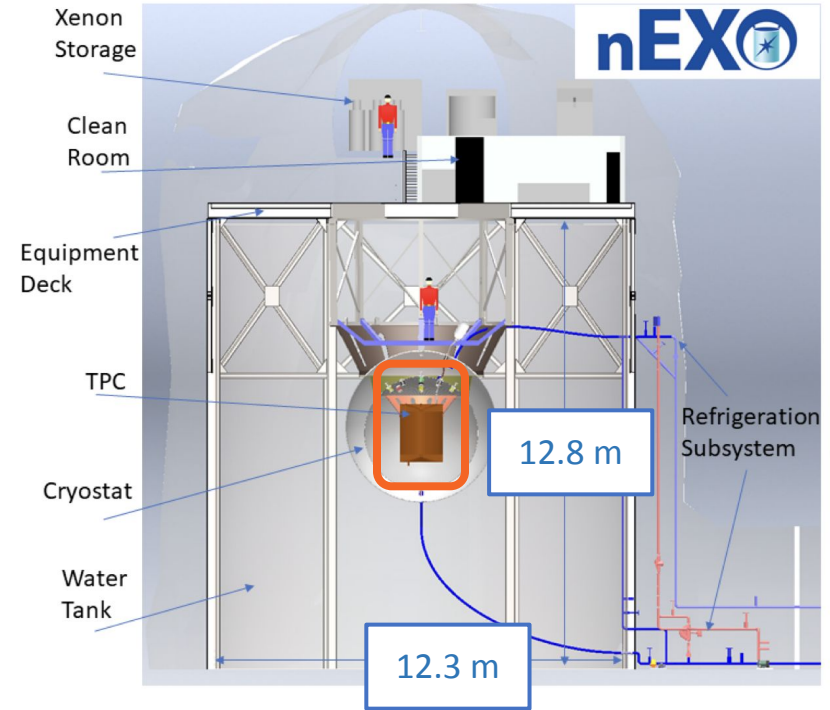

[Adhikari, Govinda, et al. "nEXO: neutrinoless double beta decay search beyond 1028 year half-life sensitivity." *Journal of Physics G: Nuclear and Particle Physics* 49.1 \(2021\): 015104.](#)

The nEXO $0\nu\beta\beta$ Experiment

- 5-tonnes of LXe is enriched to 90% in the target isotope, ^{136}Xe
- LXe in a single-phase liquid xenon Time Projection Chamber (LXe TPC)
- **Surrounded by a large water tank for radioactive shielding and muon tagging**

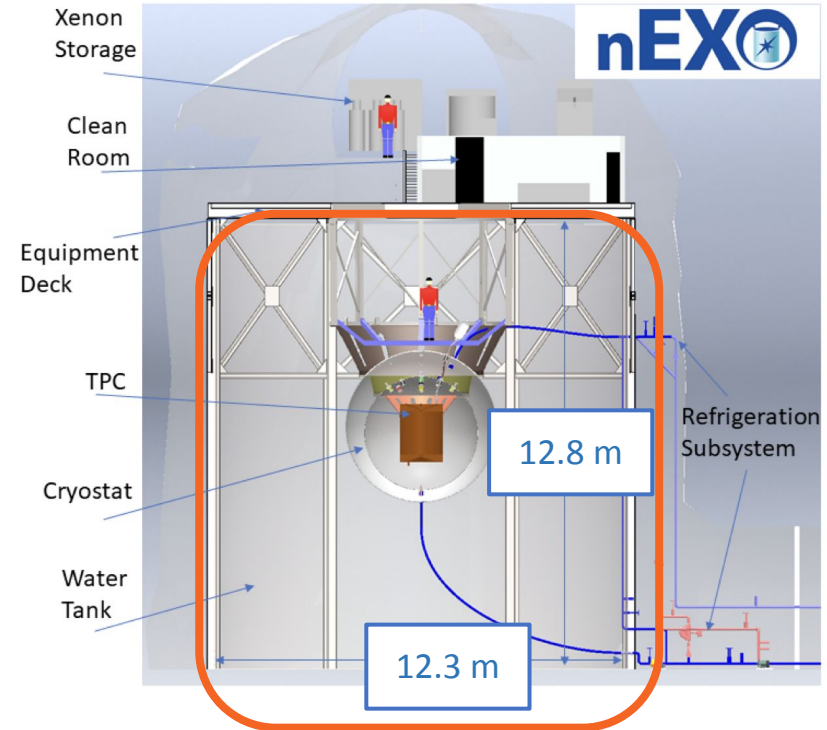

[Adhikari, Govinda, et al. "nEXO: neutrinoless double beta decay search beyond 1028 year half-life sensitivity." *Journal of Physics G: Nuclear and Particle Physics* 49.1 \(2021\): 015104.](#)

The nEXO $0\nu\beta\beta$ Experiment

- 5-tonnes of LXe is enriched to 90% in the target isotope, ^{136}Xe
- LXe in a single-phase liquid xenon Time Projection Chamber (LXe TPC)
- Surrounded by a large water tank for radioactive shielding and muon tagging

[Adhikari, Govinda, et al. "nEXO: neutrinoless double beta decay search beyond 1028 year half-life sensitivity." *Journal of Physics G: Nuclear and Particle Physics* 49.1 \(2021\): 015104.](#)

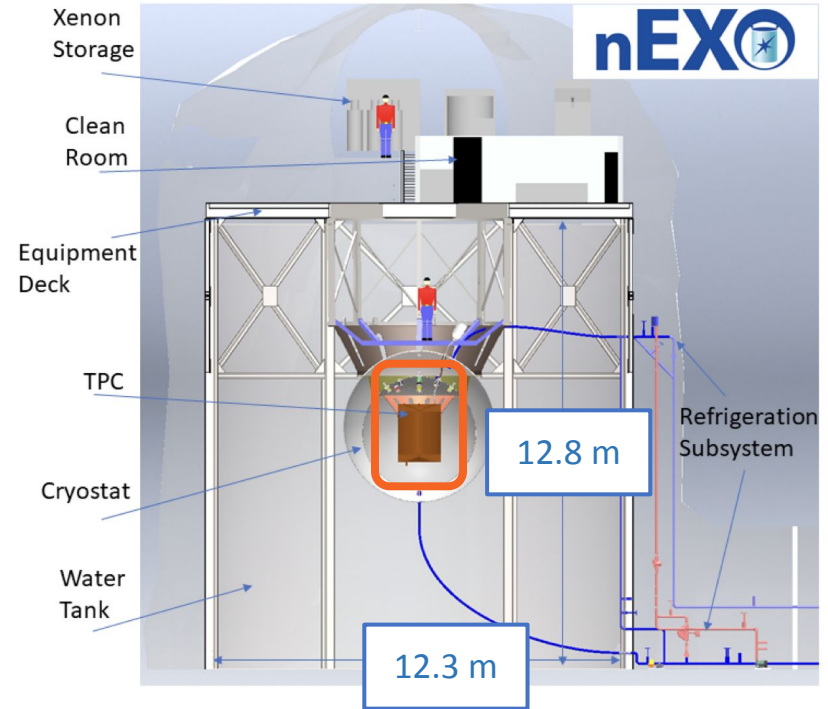

nEXO's Time Projection Chamber (TPC)

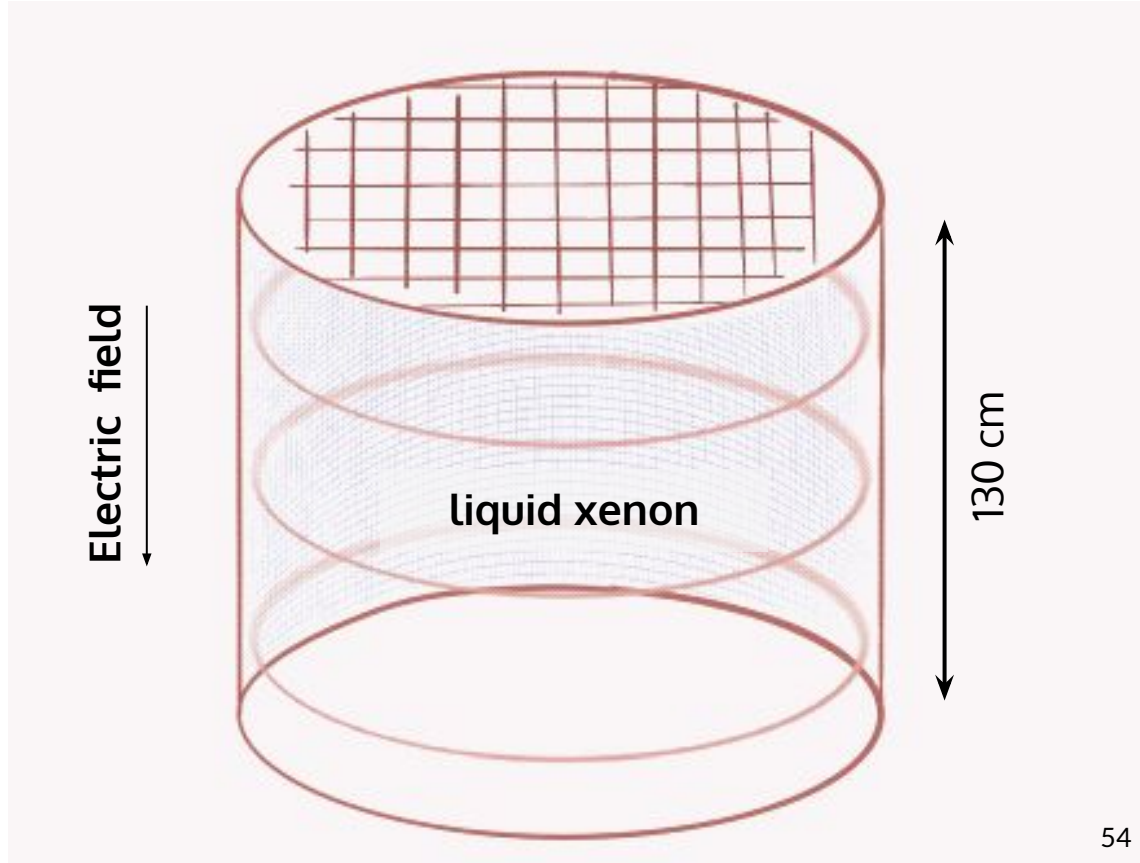

nEXO's Time Projection Chamber (TPC)

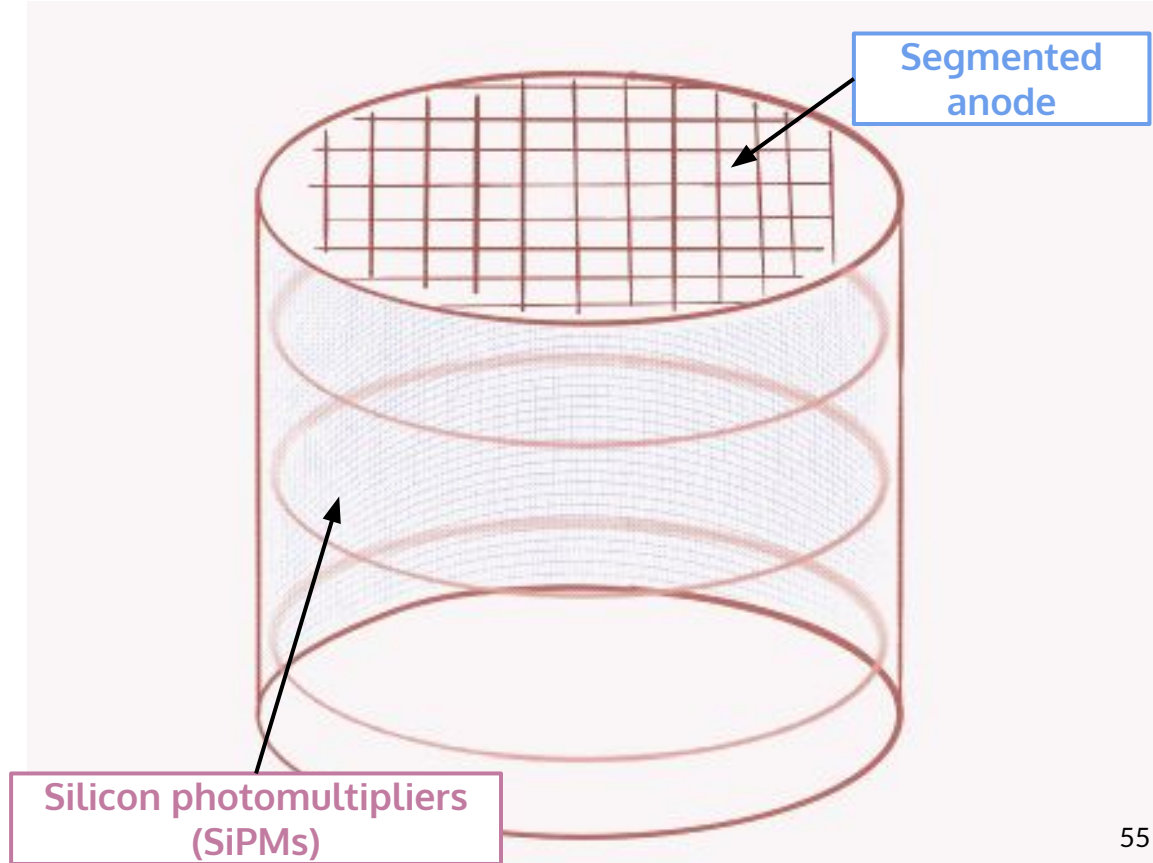

nEXO's Time Projection Chamber (TPC)

1. Flash of **scintillation light** (**prompt**)
2. **Ionization charge detected** (**delayed**, provides **x-y projection**)
3. **Time difference of light+charge** readout provides **z-position**

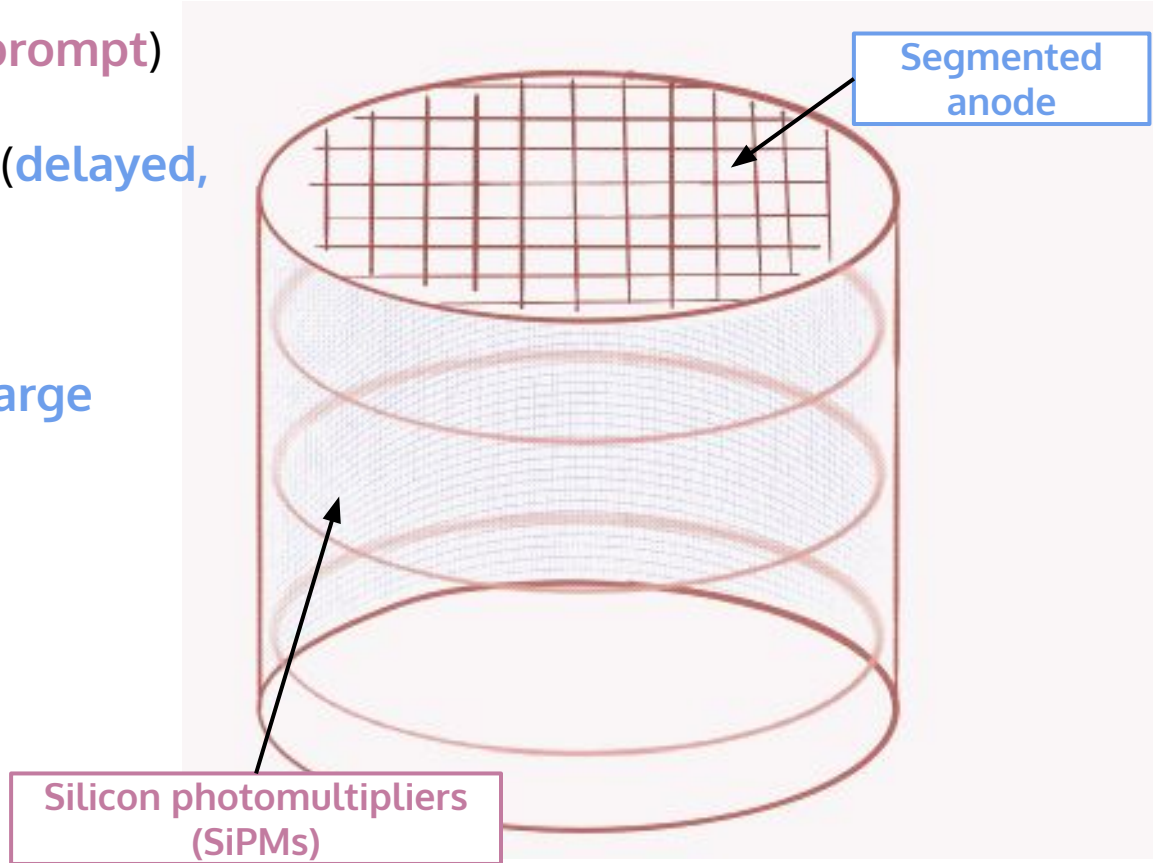

nEXO's Time Projection Chamber (TPC)

1. Flash of scintillation light (prompt)
2. Ionization charge detected (delayed, provides x-y projection)
3. Time difference of light+charge readout provides z-position

light+charge also improves energy resolution, σ_E !

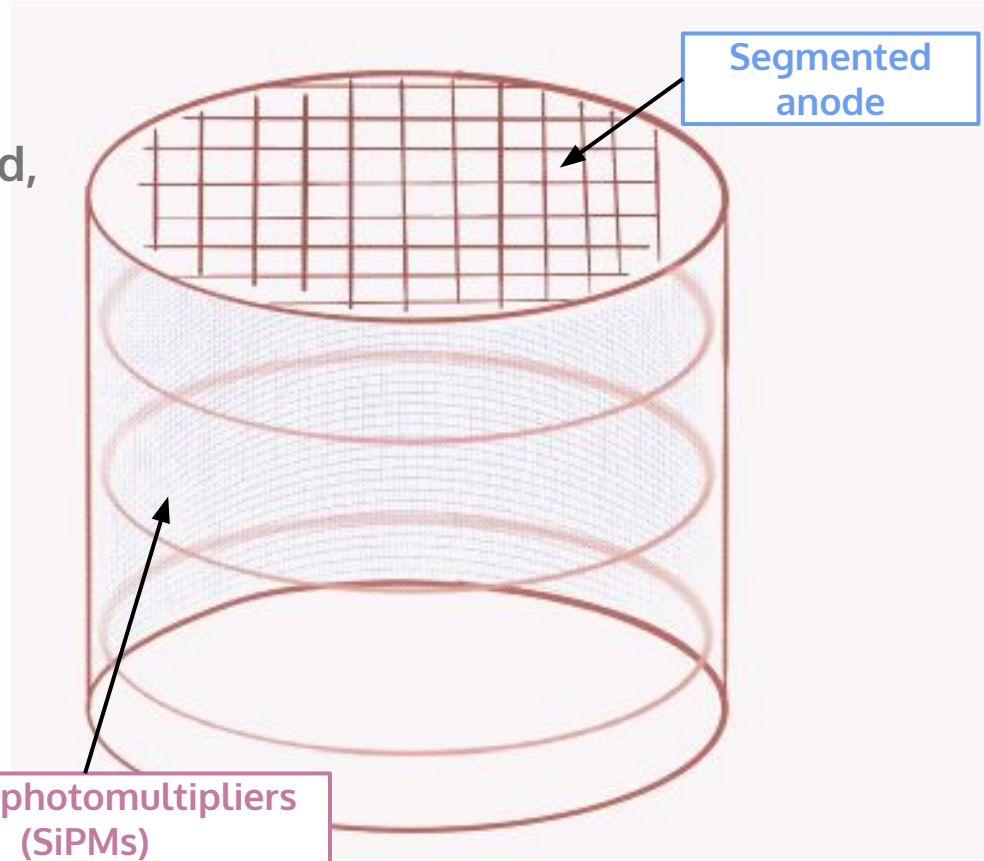

3 high-level analysis variables separate **signal** from backgrounds in nEXO

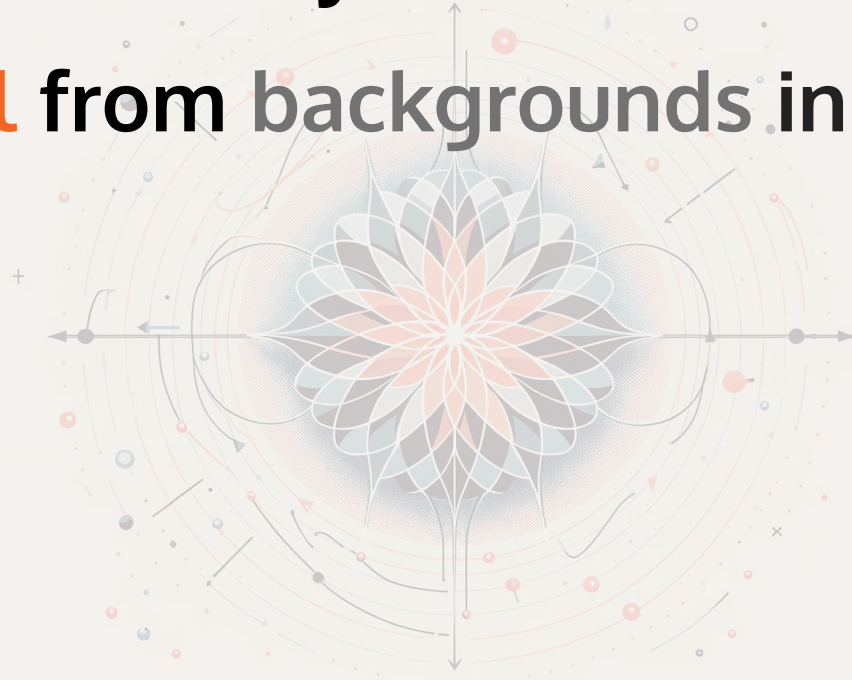

3 high-level analysis variables separate
signal from backgrounds in nEXO



Energy, Standoff, Topology

3 high-level analysis variables separate

signal from backgrounds

1. Energy

$$Q_{\beta\beta} = 2.458 \text{ MeV}$$

$$\sigma_E < 1\%$$

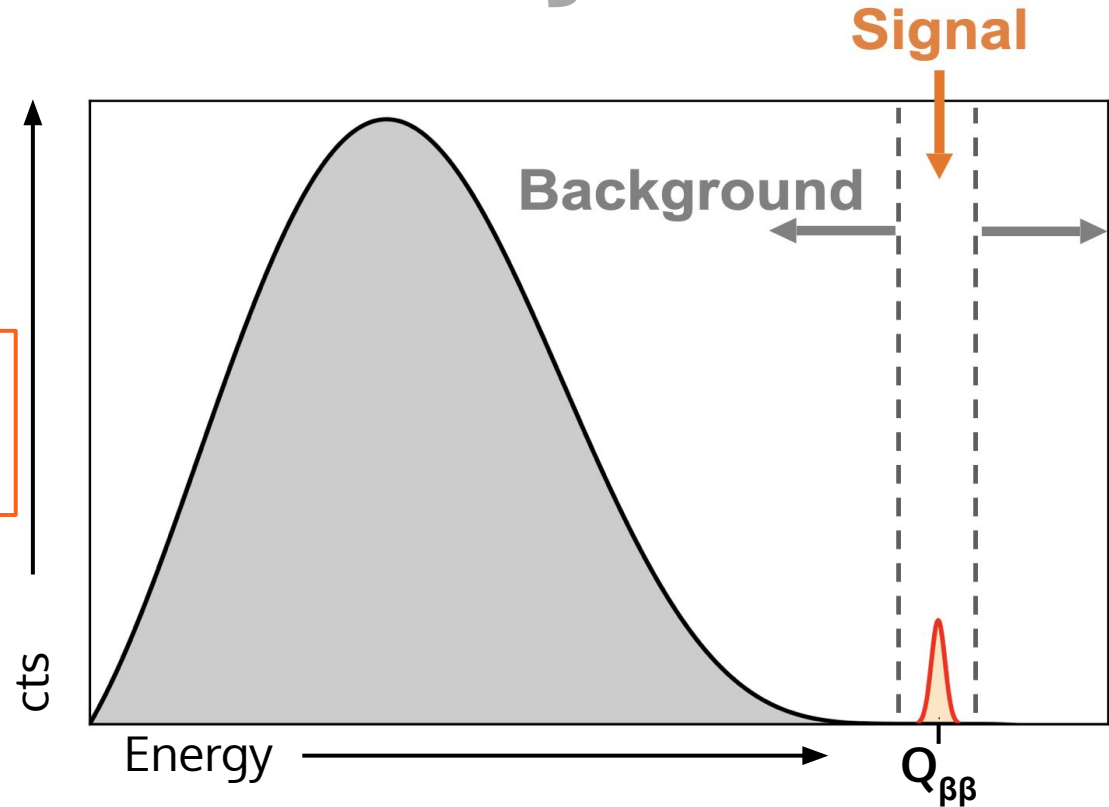

3 high-level analysis variables separate

signal from backgrounds

2. Standoff distance

Signal is **homogeneous**
Backgrounds are attenuated

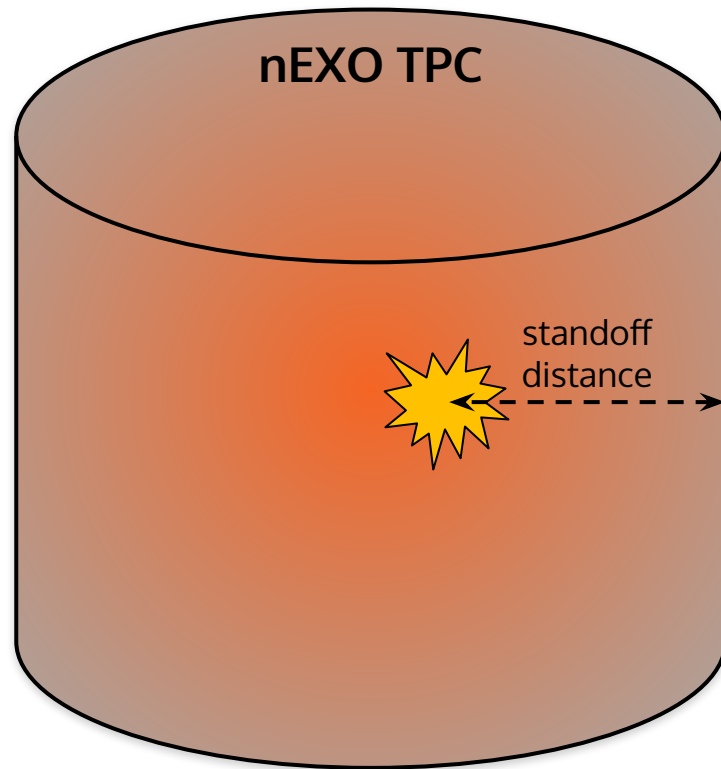

3 high-level analysis variables separate

signal from backgrounds

3. Topology

Deep Neural Network (DNN) discriminator

Signal DNN score $\rightarrow 1$

Background DNN $\rightarrow 0$

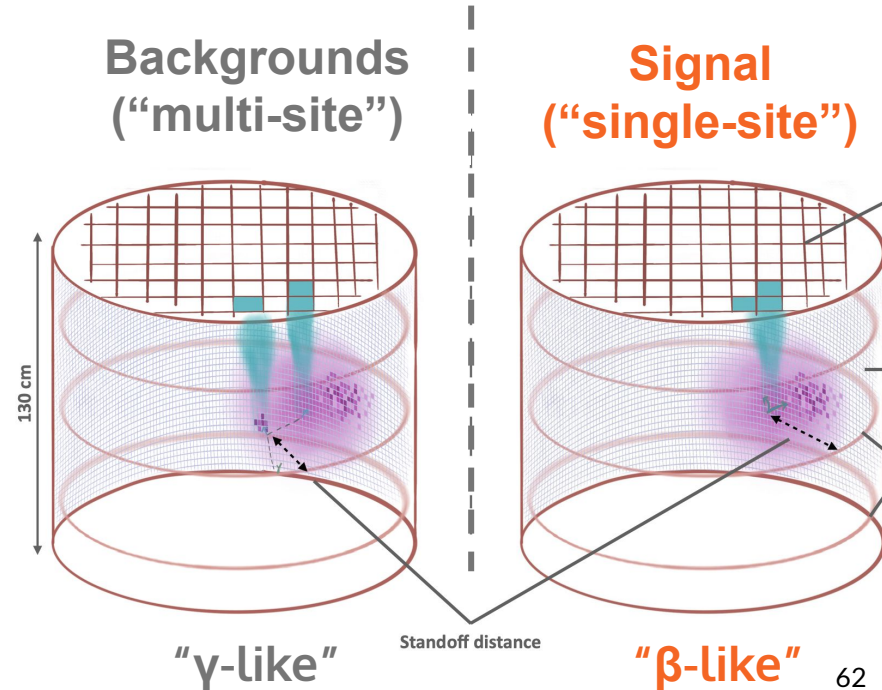

[Li, Z., et al. "Simulation of charge readout with segmented tiles in nEXO." *Journal of Instrumentation* 14.09 \(2019\): P09020.](#)

3 high-level analysis variables separate

signal from backgrounds

3. Topology

Deep Neural Network (DNN) discriminator

Signal DNN score $\rightarrow 1$

Background DNN $\rightarrow 0$

Backgrounds
("multi-site")

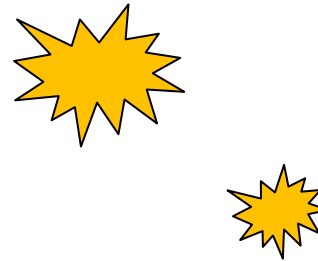

" γ -like"

Signal
("single-site")

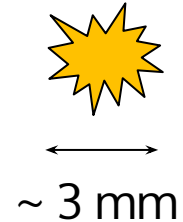

" β -like"

3 high-level analysis variables separate

signal from backgrounds

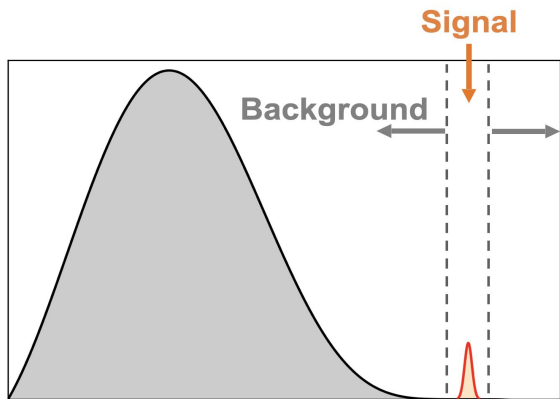

Energy

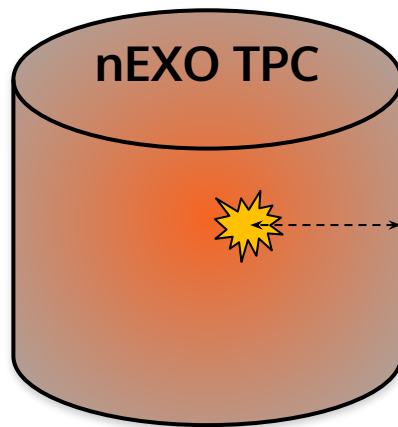

Standoff

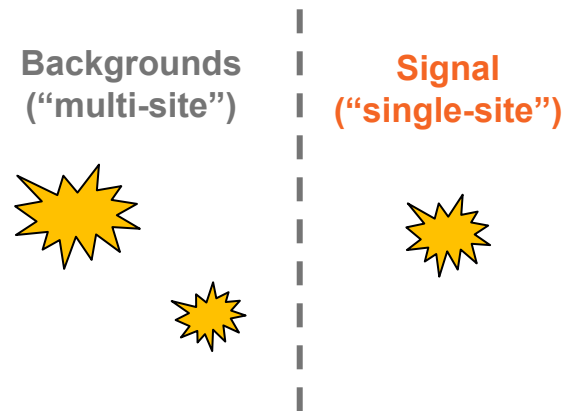

Topology

3 high-level analysis variables separate

signal from backgrounds

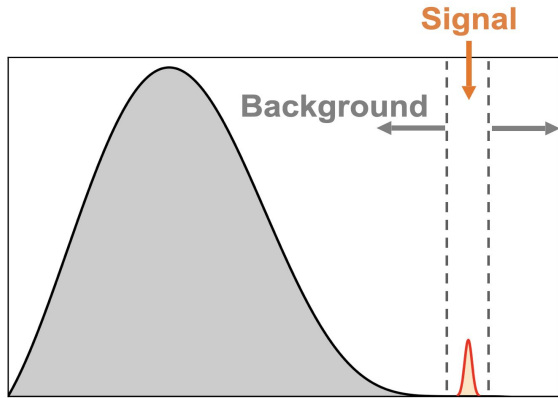

Energy

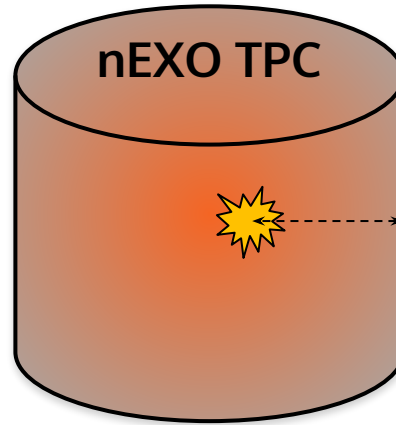

Standoff

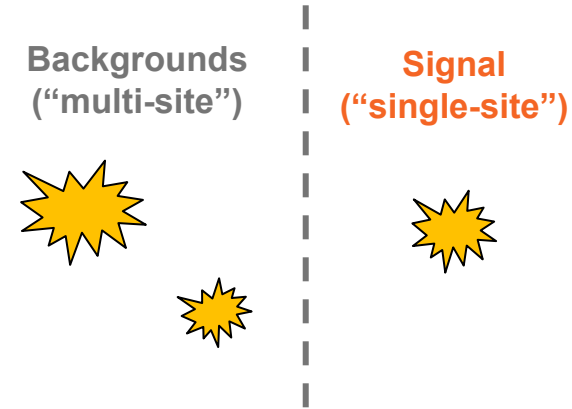

Topology

What does a nEXO dataset look like?

3D data (example 10 yr dataset)

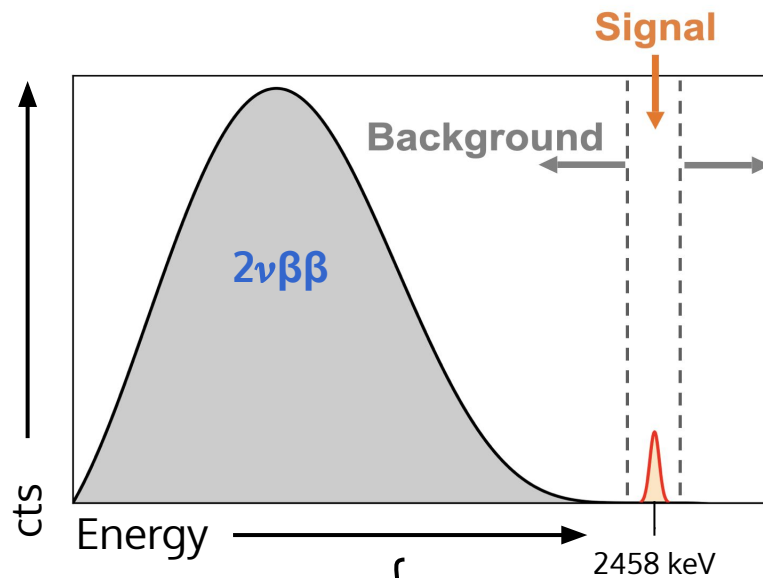
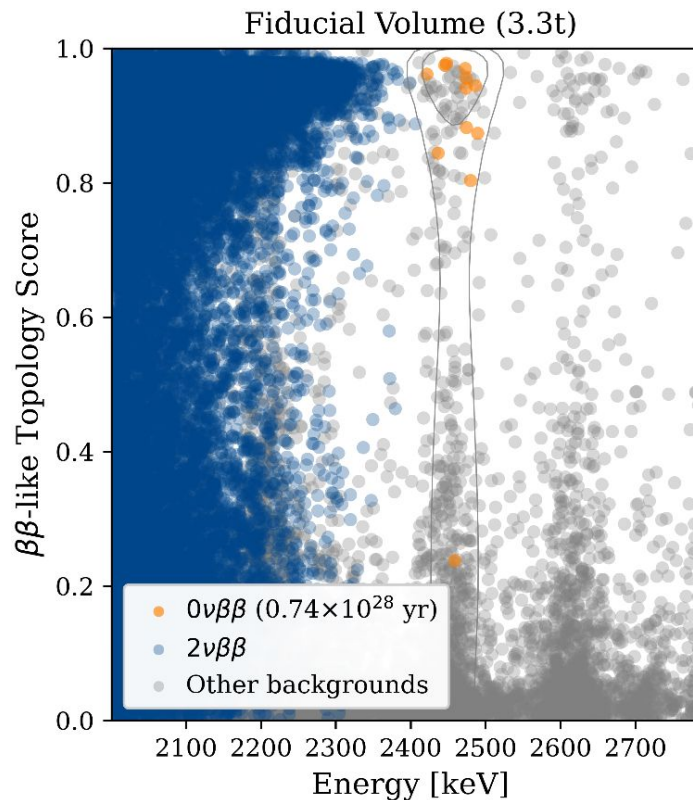

3D data (example 10 yr dataset)

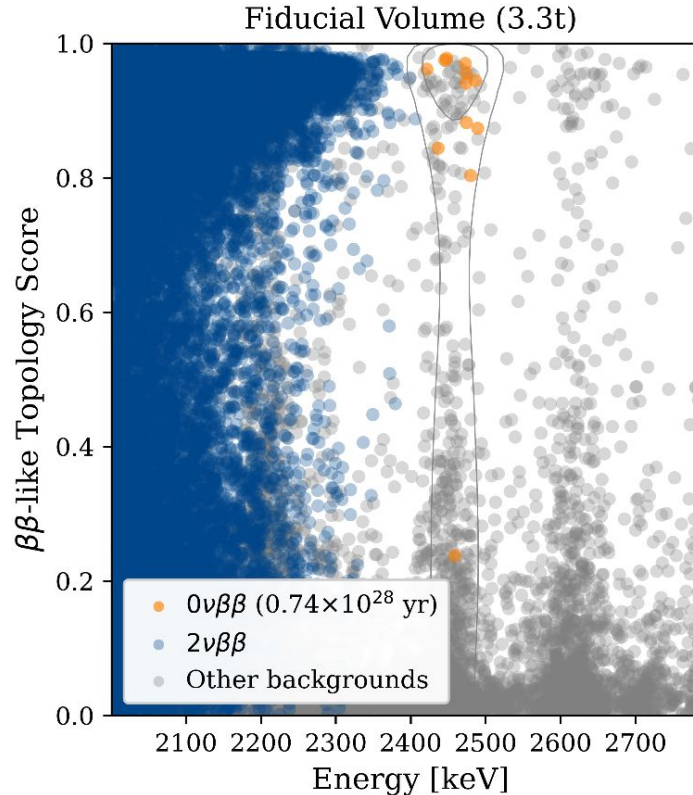

Signal
("single-site")



" β -like"



Backgrounds
("multi-site")

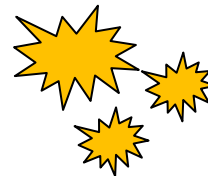

" γ -like"

3D data (example 10 yr dataset)

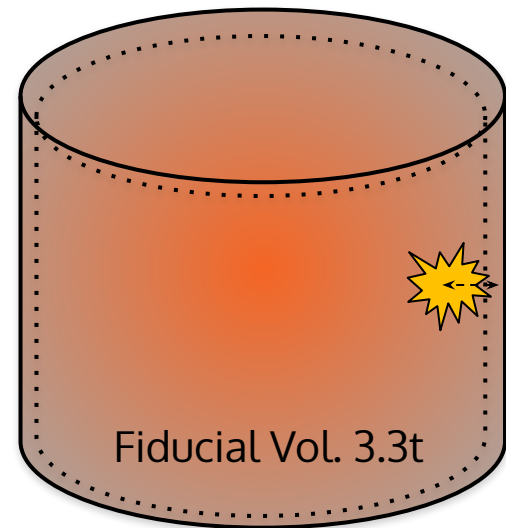
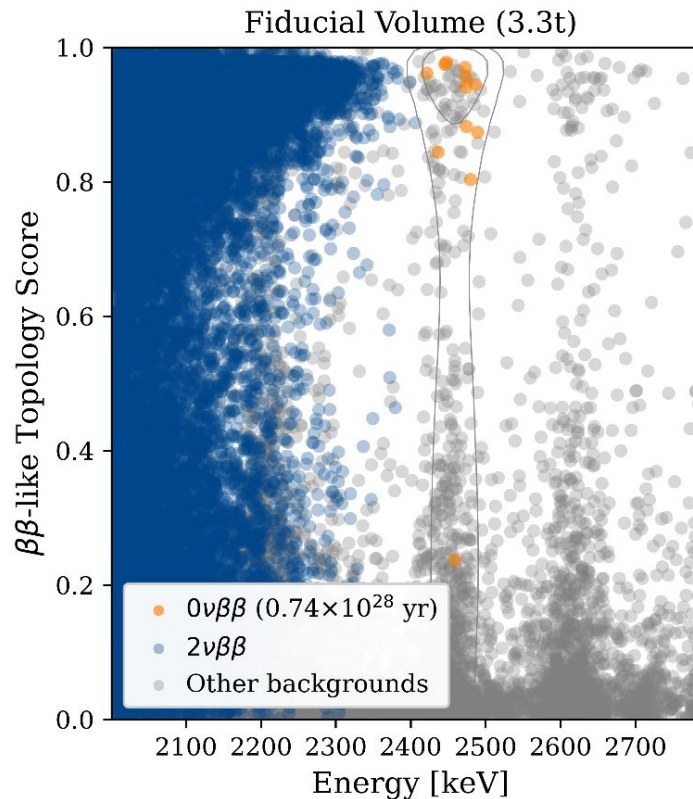

3D data (example 10 yr dataset)

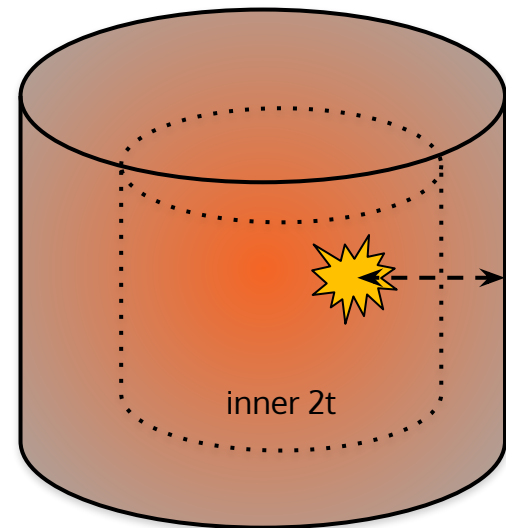
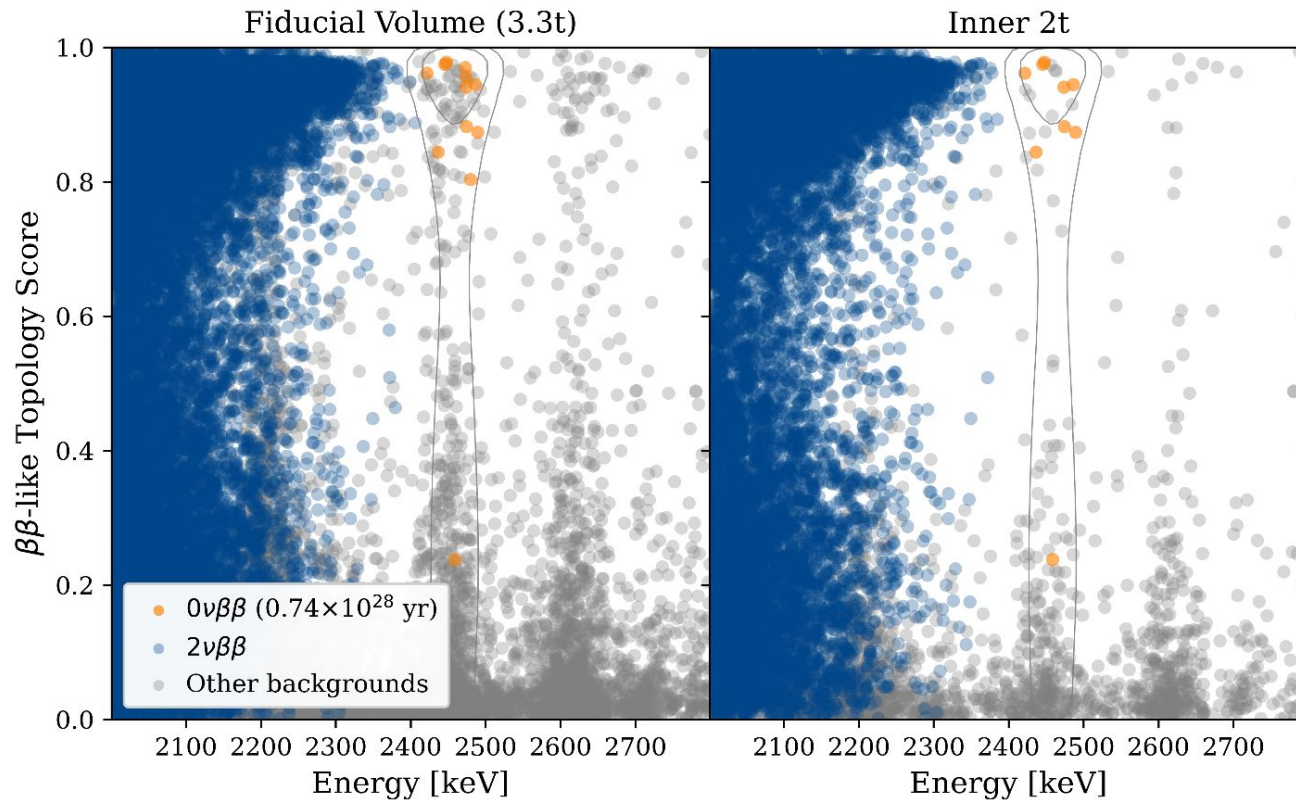

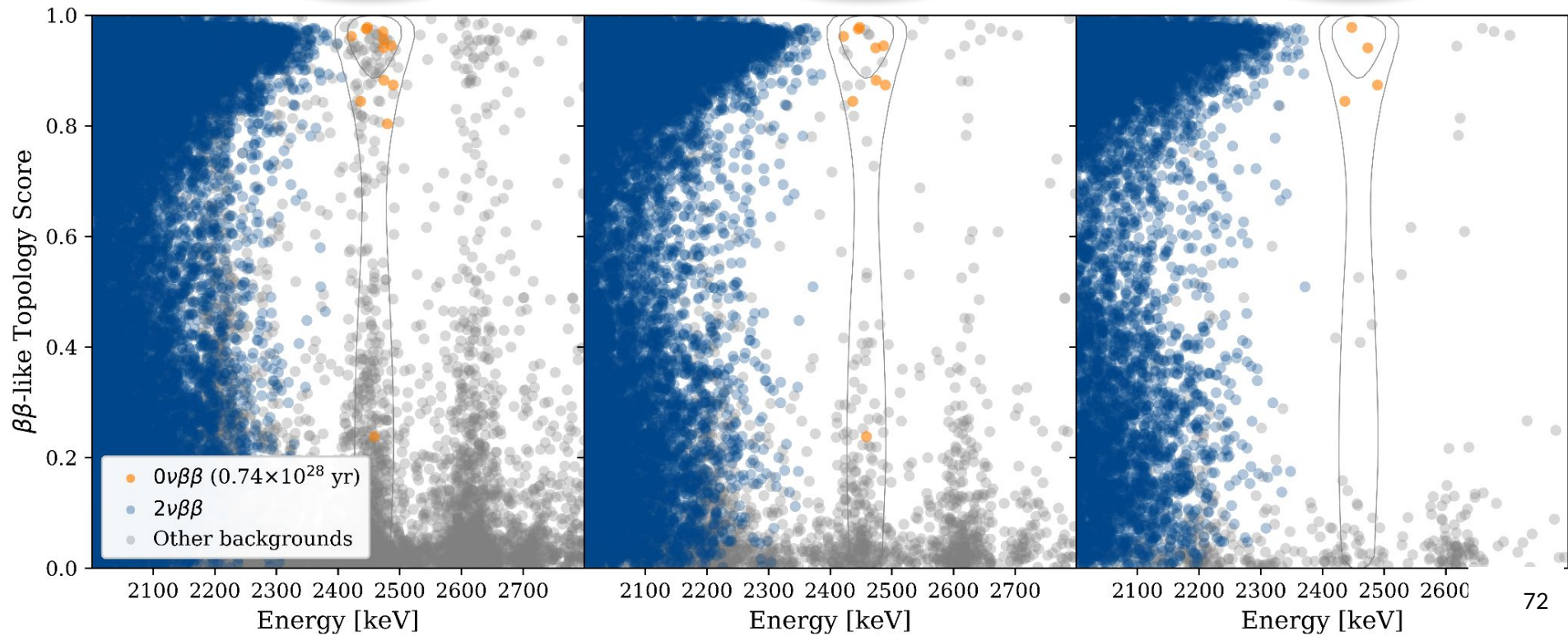
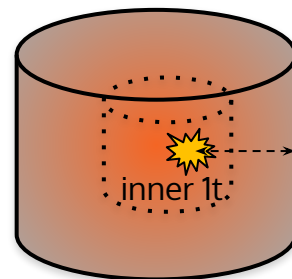
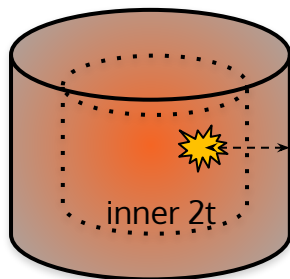
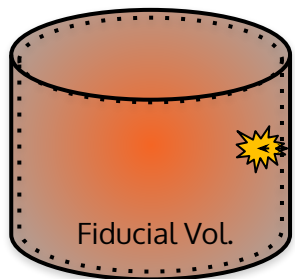

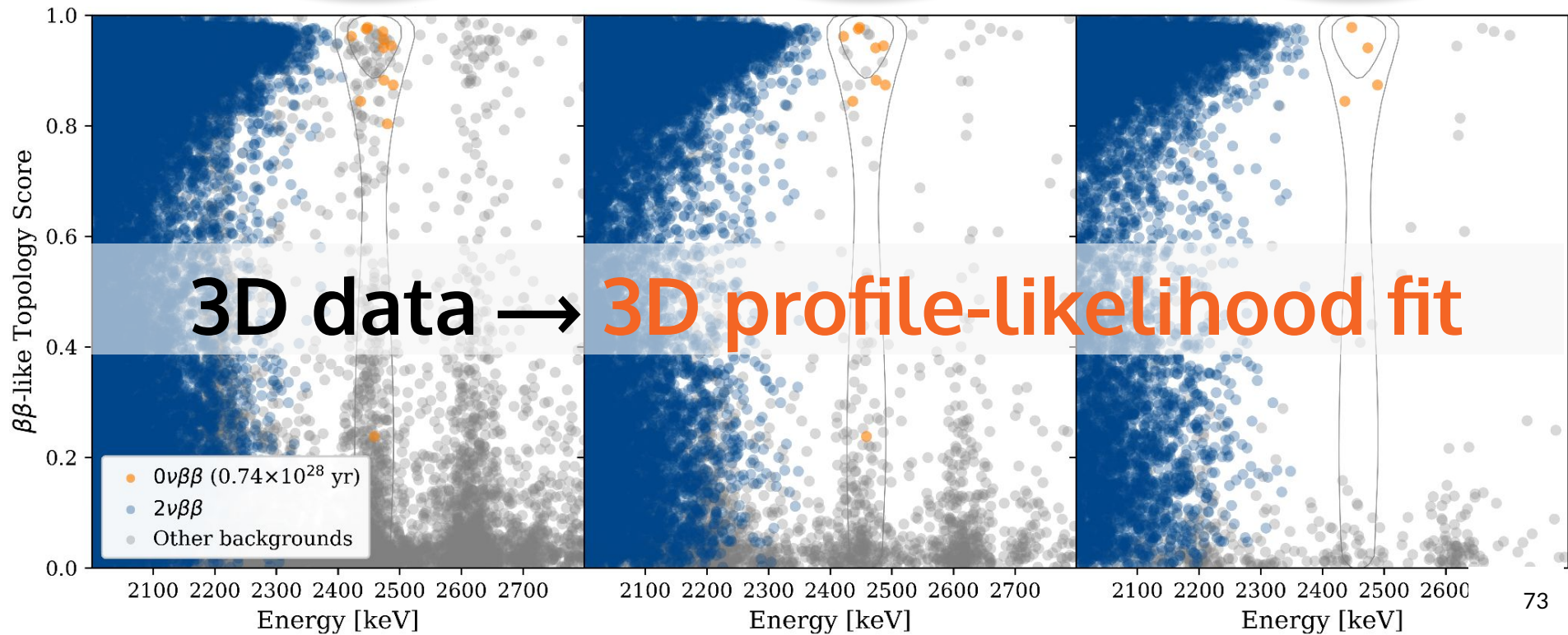
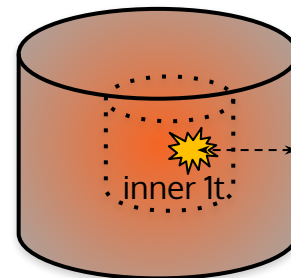
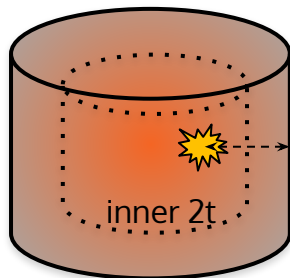
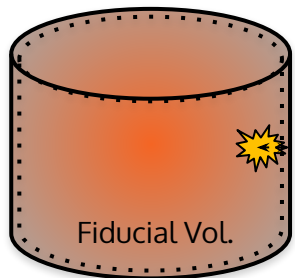

Cosmogenic Backgrounds



MARK GARLICK/SCIENCE PHOTO LIBRARY/Alamy

We shield against muons by going underground → **SNOLAB**

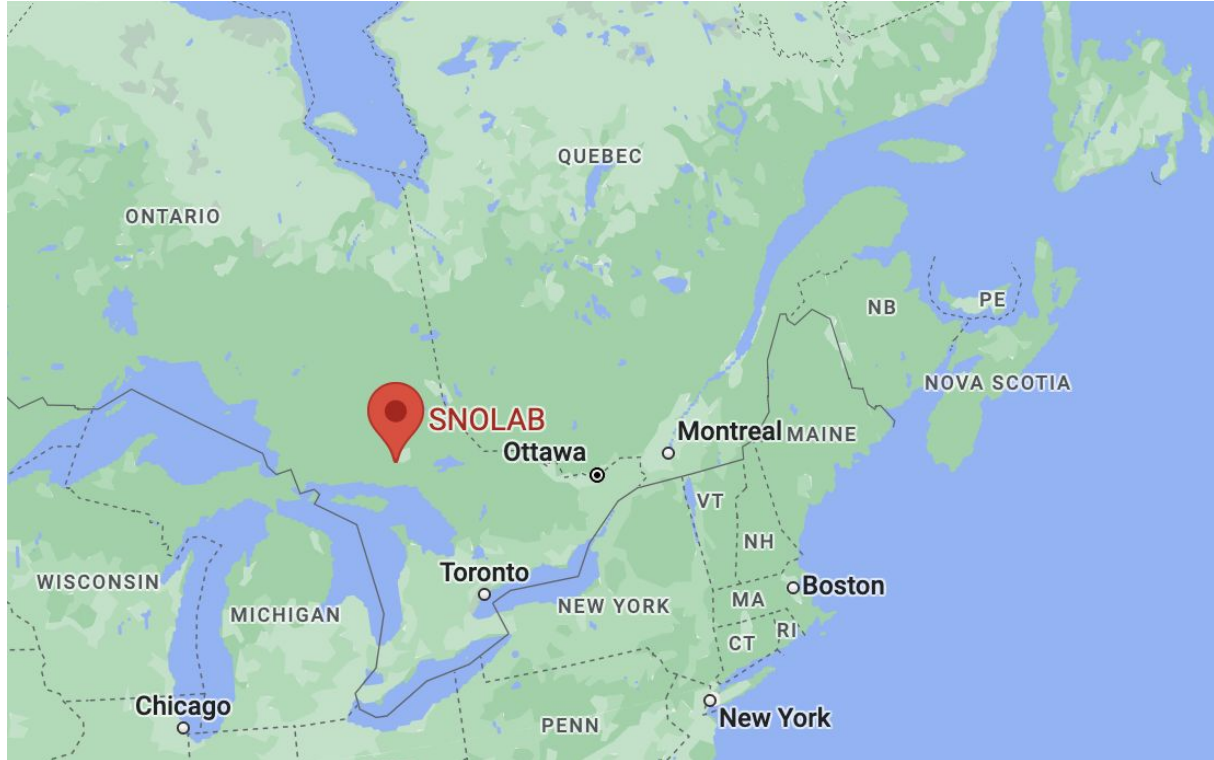

How deep is your ~~love~~ mine?

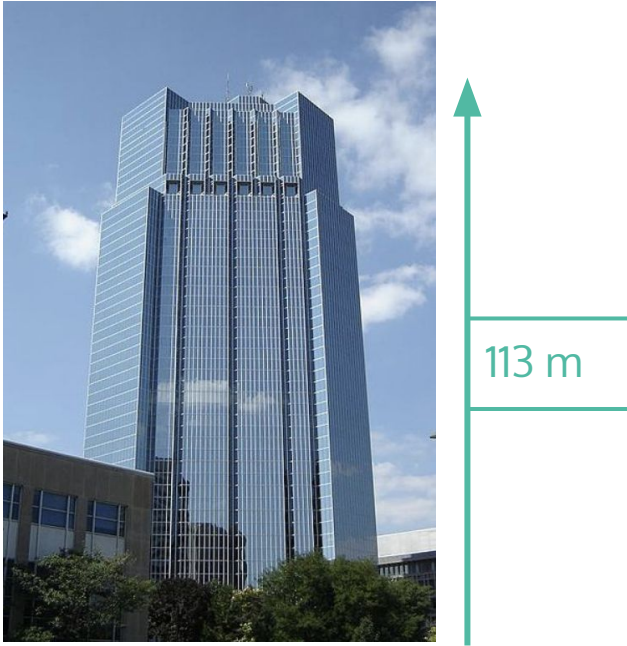

One London Place, London, ON



~20x taller than the tallest building in London*!

2 km

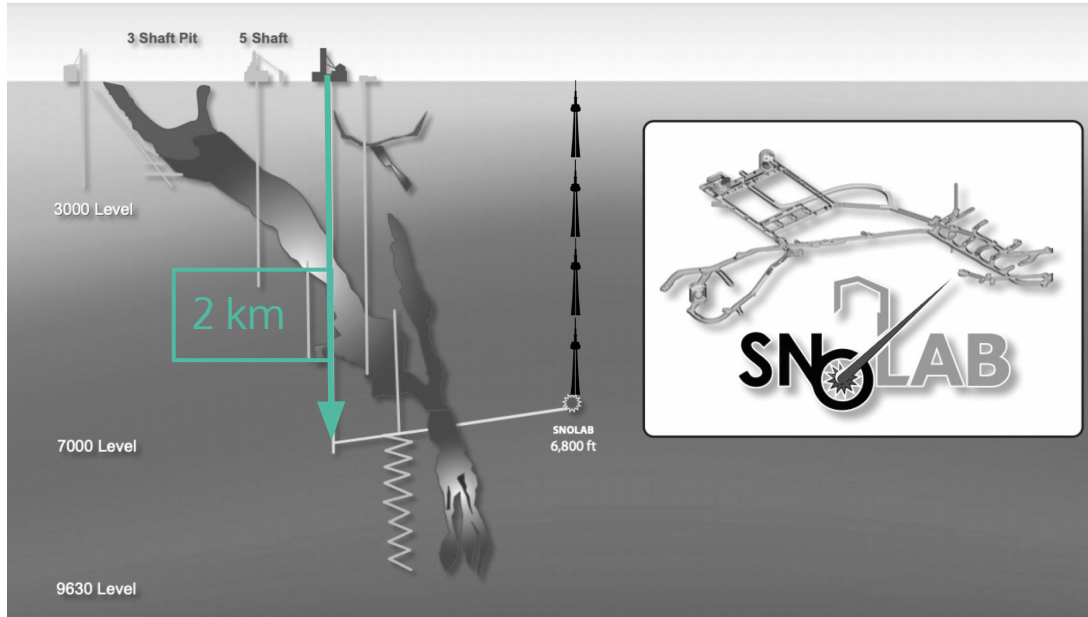

*Ontario

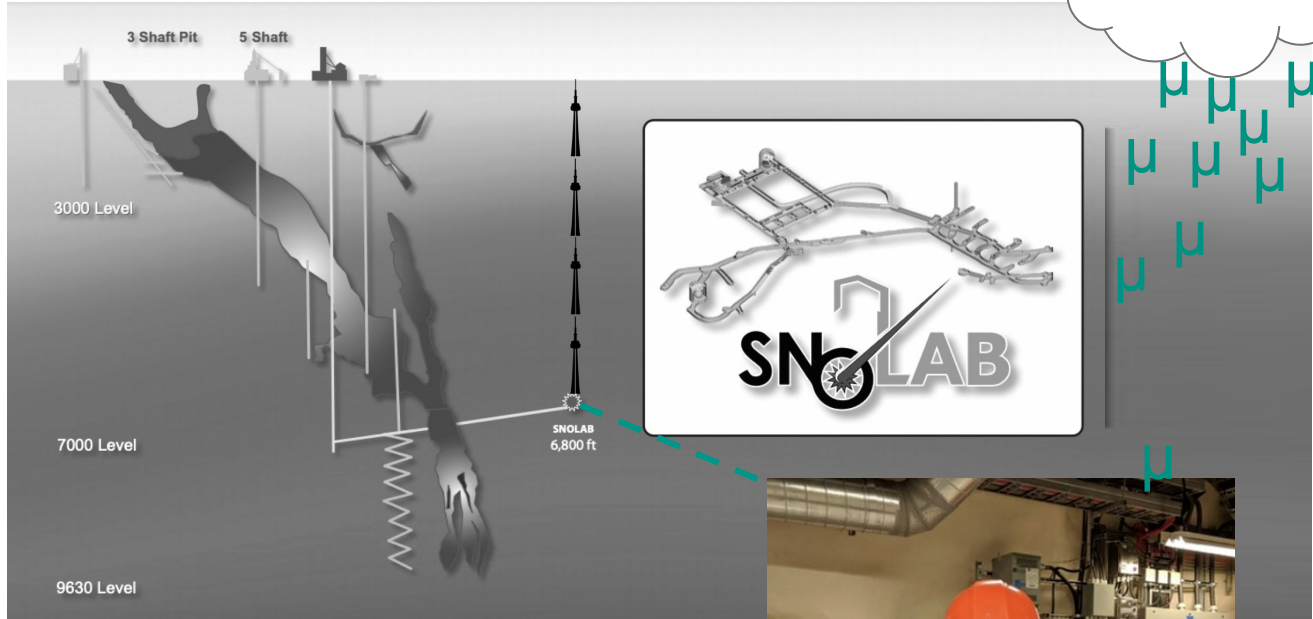

Cosmogenic ^{137}Xe production

1. $\mu^\pm \rightarrow \pi^\pm + p + n + \dots$

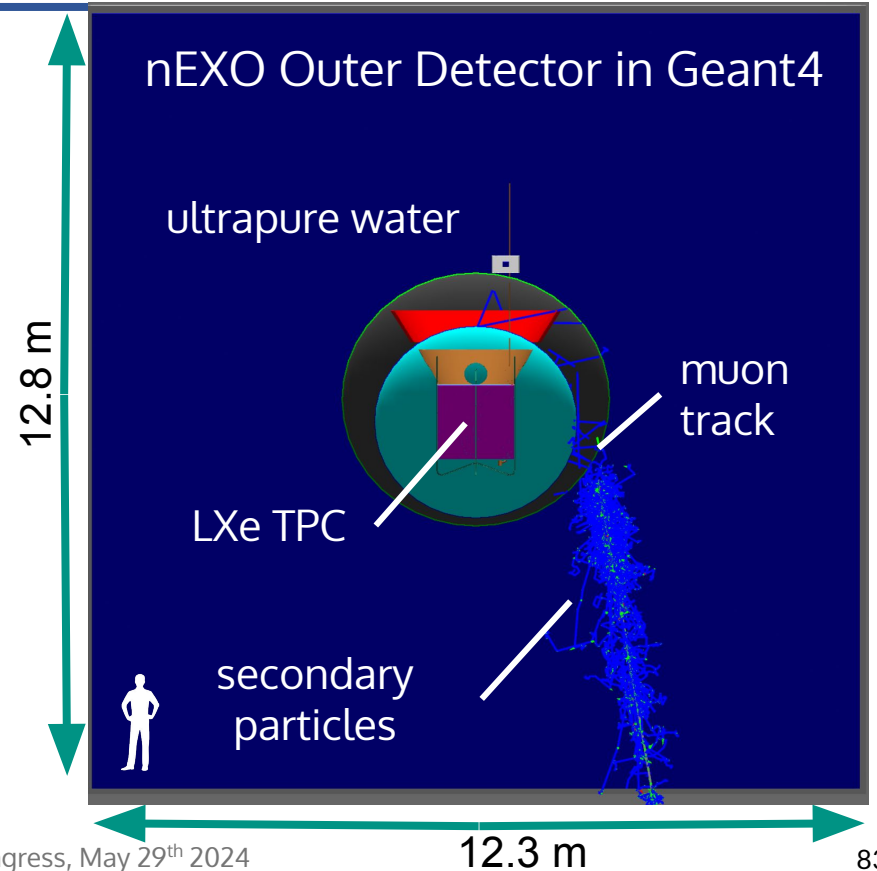

Cosmogenic ^{137}Xe production

1. $\mu^\pm \rightarrow \pi^\pm + p + n + \dots$

^{136}Xe

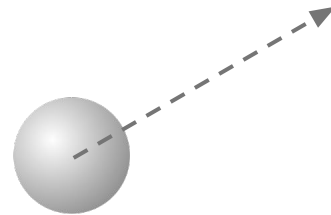
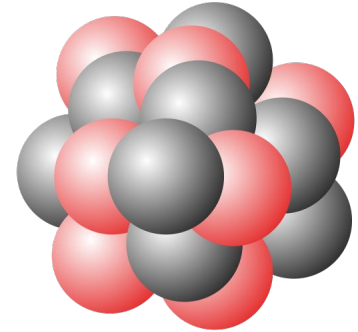

Cosmogenic ^{137}Xe production

1. $\mu^\pm \rightarrow \pi^\pm + p + n + \dots$

... neutron thermalization ~ 100 's μs in LXe...

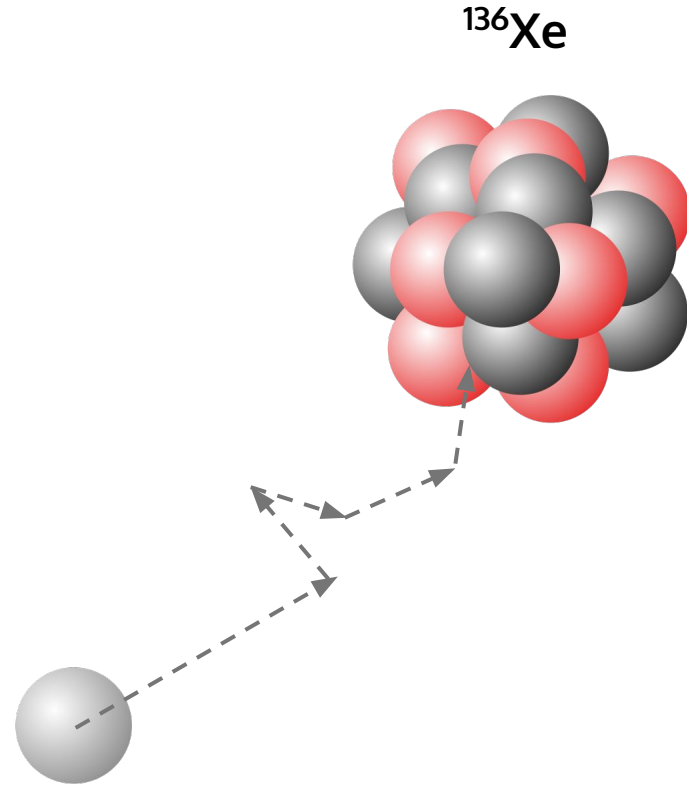

Cosmogenic ^{137}Xe production



... neutron thermalization ~ 100 's μs ...

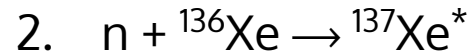

$^{137}\text{Xe}^*$

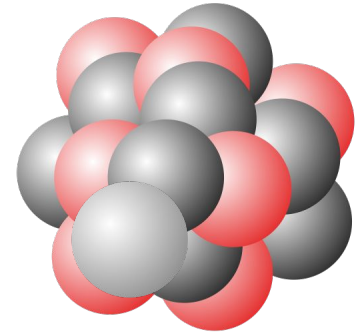

Cosmogenic ^{137}Xe production

1. $\mu^\pm \rightarrow \pi^\pm + p + n + \dots$

... neutron thermalization ~ 100 's μs ...

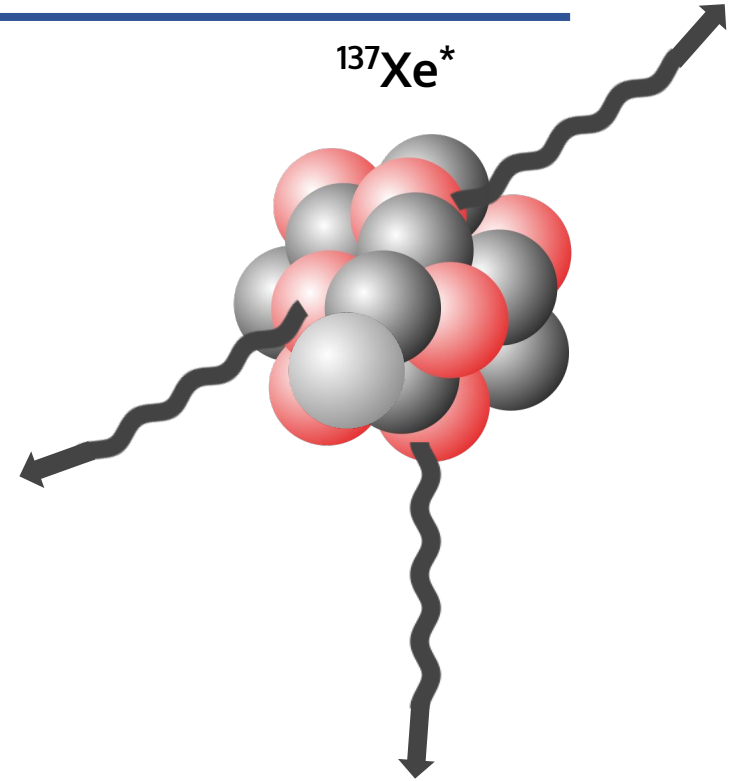

Cosmogenic ^{137}Xe production

1. $\mu^\pm \rightarrow \pi^\pm + p + n + \dots$

... neutron thermalization ~ 100 's μs ...



... β -decay half-life ~ 3.8 minutes

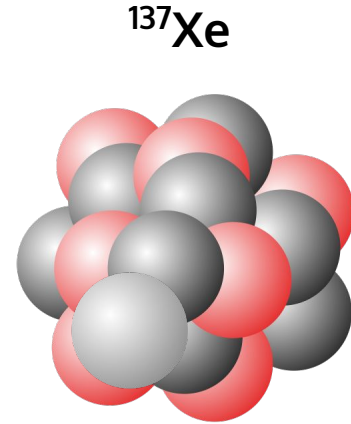

Cosmogenic ^{137}Xe production

1. $\mu^\pm \rightarrow \pi^\pm + p + n + \dots$

... neutron thermalization ~ 100 's μs ...



... β -decay half-life ~ 3.8 minutes

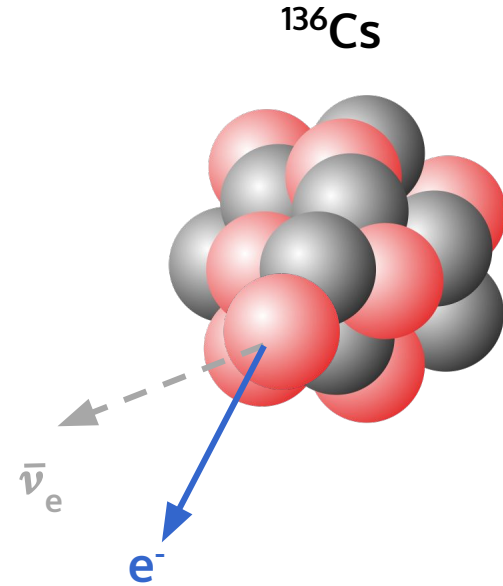
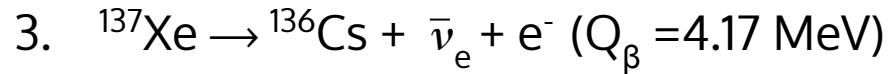

Cosmogenic ^{137}Xe production

1. $\mu^\pm \rightarrow \pi^\pm + p + n + \dots$

... neutron thermalization ~ 100 's μs ...

2. $n + ^{136}\text{Xe} \rightarrow ^{137}\text{Xe}^* + \gamma\text{'s (4.025 MeV)}$

... β -decay half-life ~ 3.8 minutes

3. $^{137}\text{Xe} \rightarrow ^{136}\text{Cs} + \bar{\nu}_e + e^-$ ($Q_\beta = 4.17 \text{ MeV}$)

background!

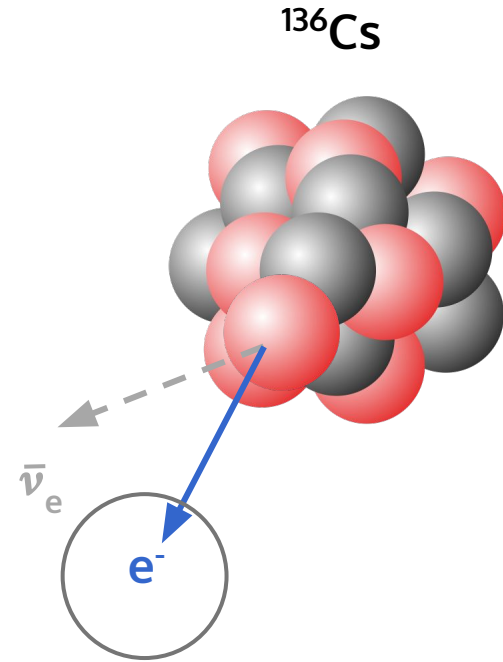

β -decays of ^{137}Xe can look like $0\nu\beta\beta$ signals!

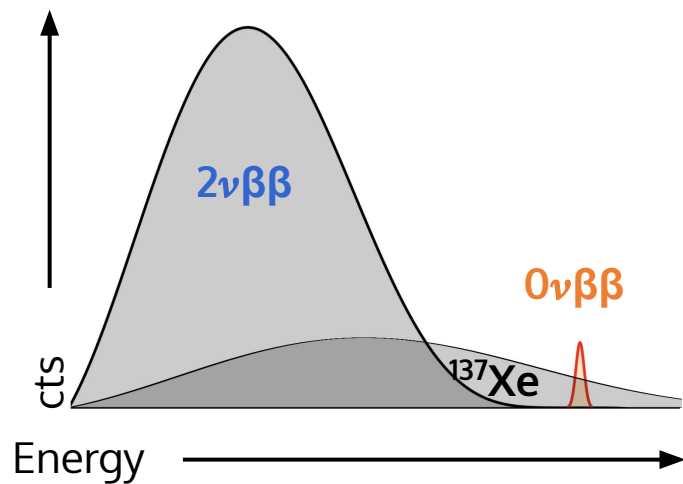

β -decays of ^{137}Xe can look like $0\nu\beta\beta$ signals!

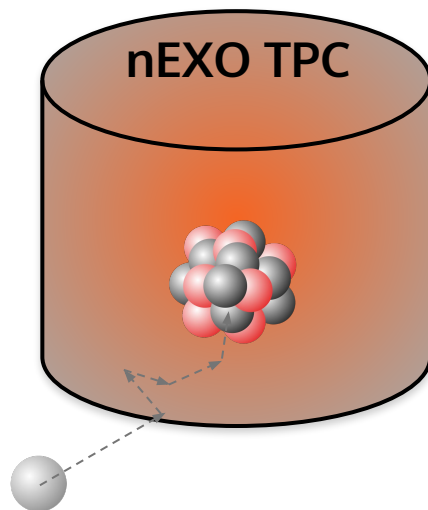
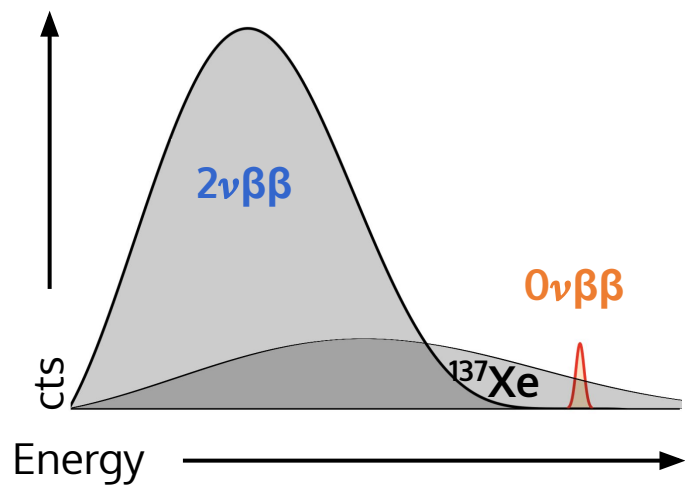

β -decays of ^{137}Xe can look like $0\nu\beta\beta$ signals!

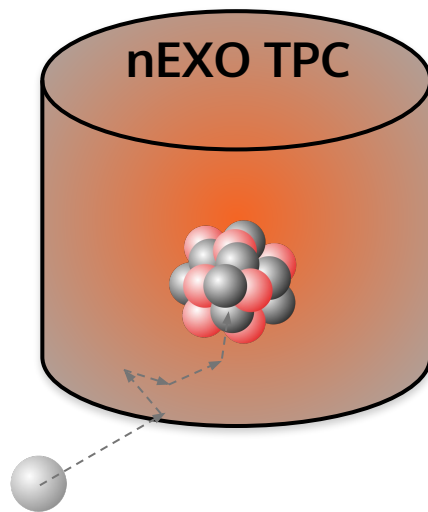
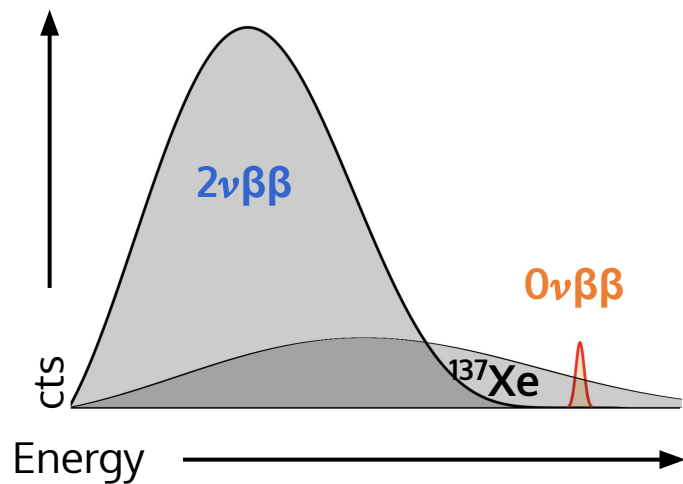

Backgrounds
("γ-like")

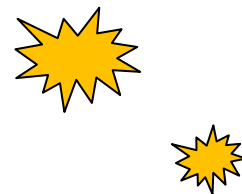

Signal
("β-like")

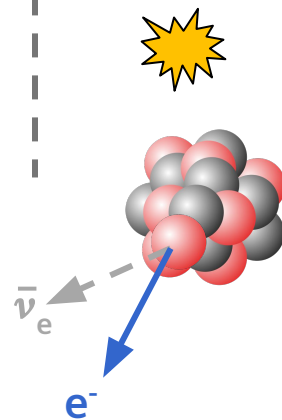

Need to quantify ^{137}Xe background rate

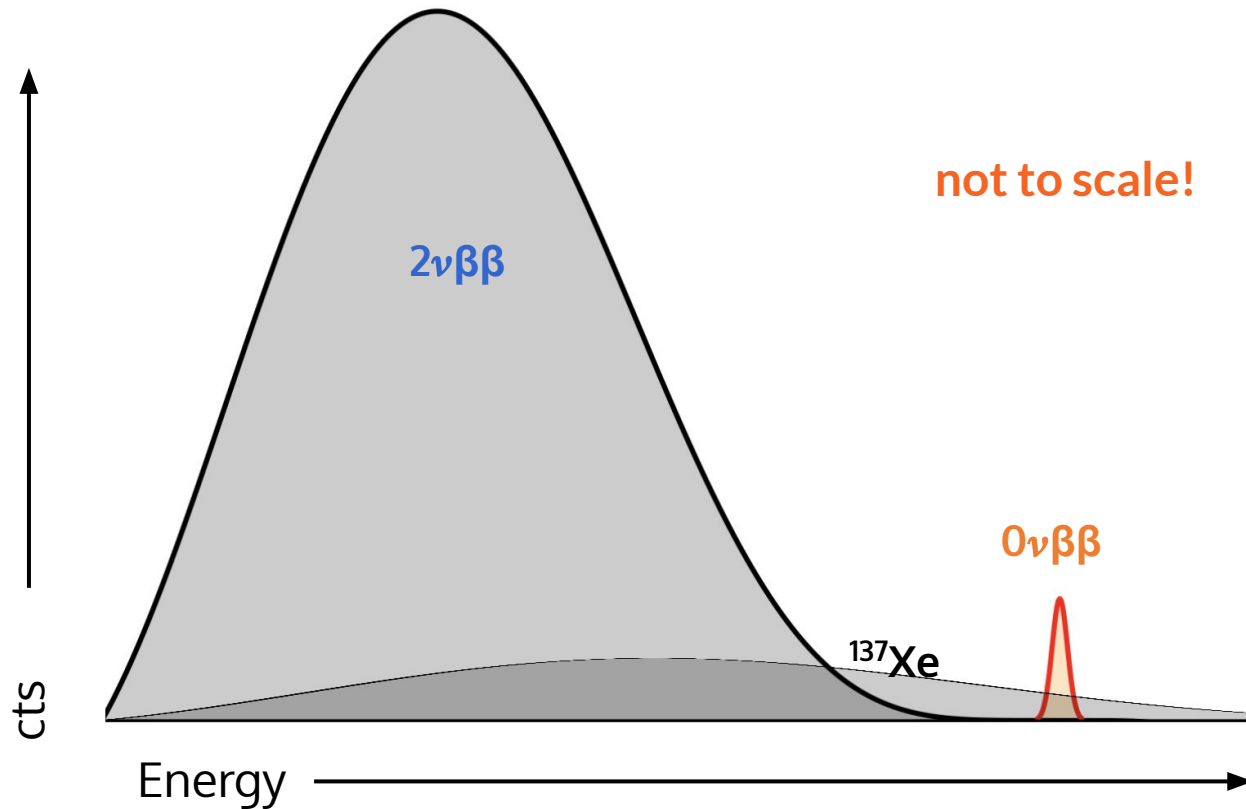

Need to quantify ^{137}Xe background rate

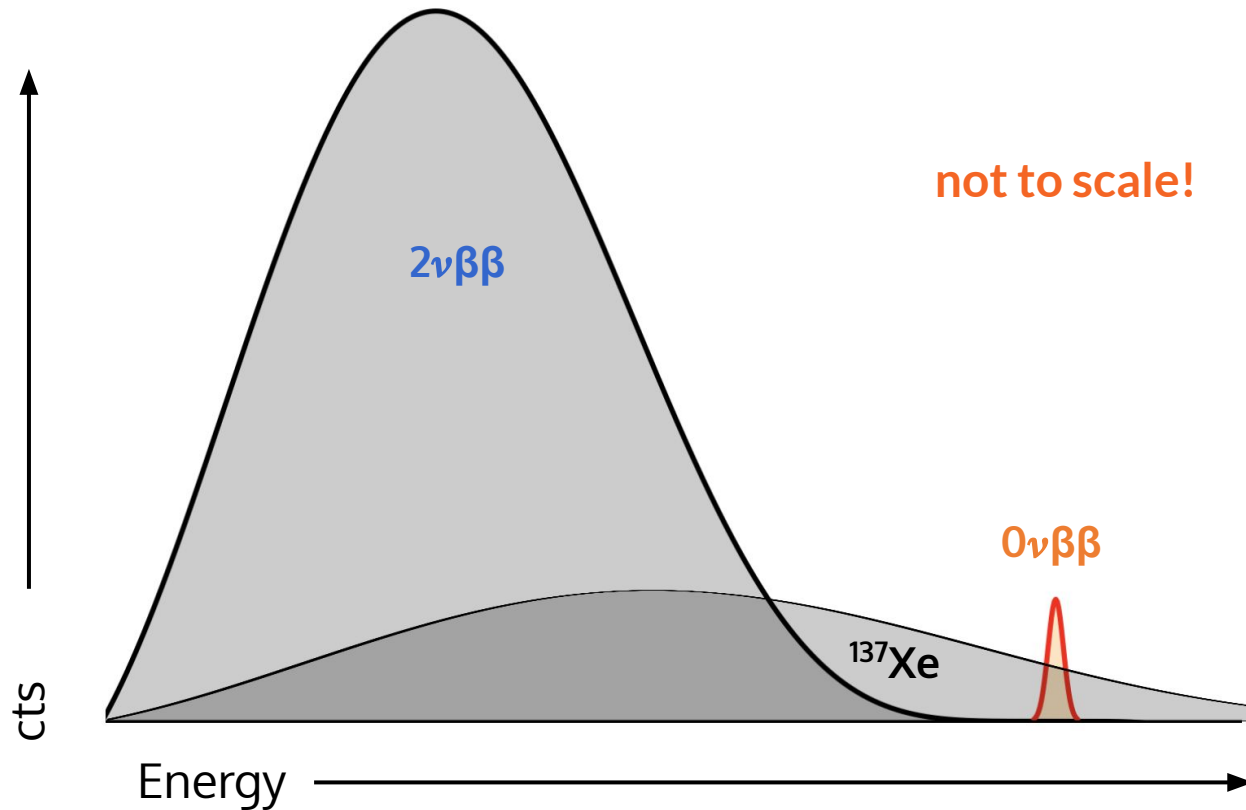

Need to quantify ^{137}Xe background rate

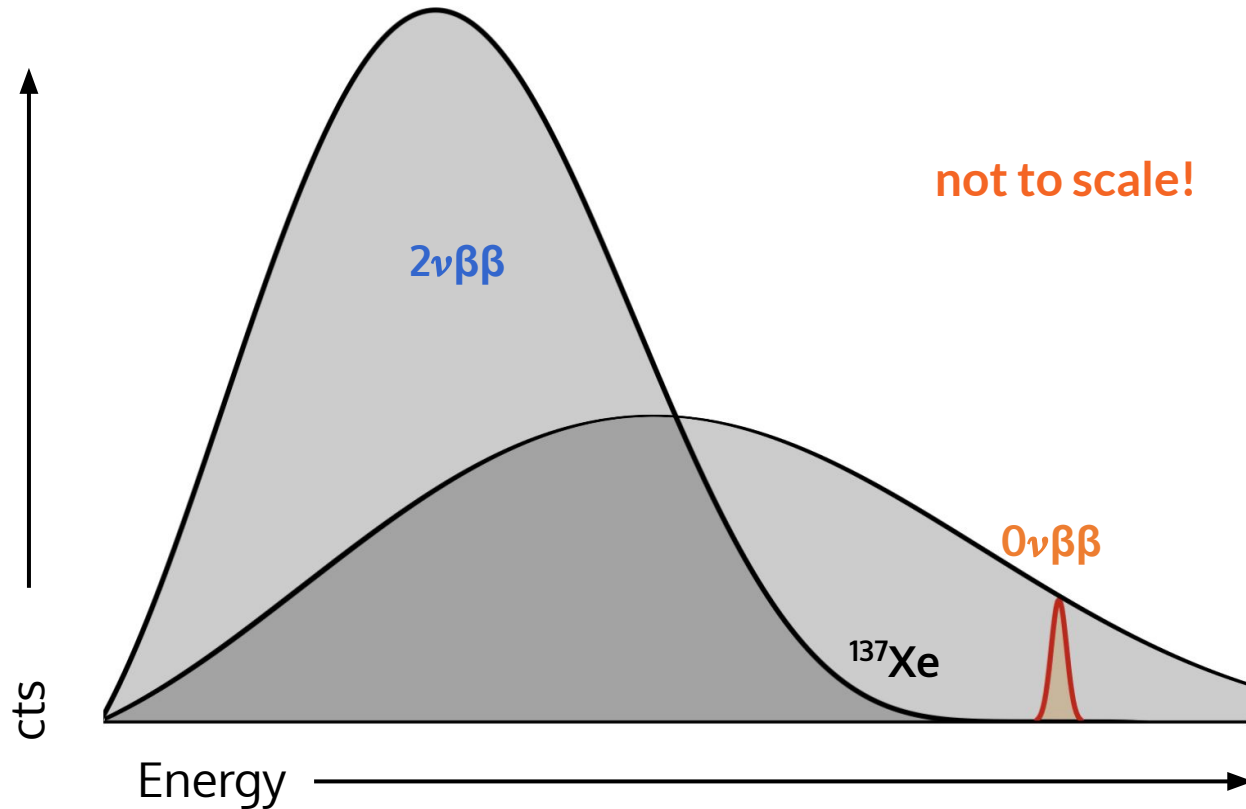

Cosmogenics Simulations

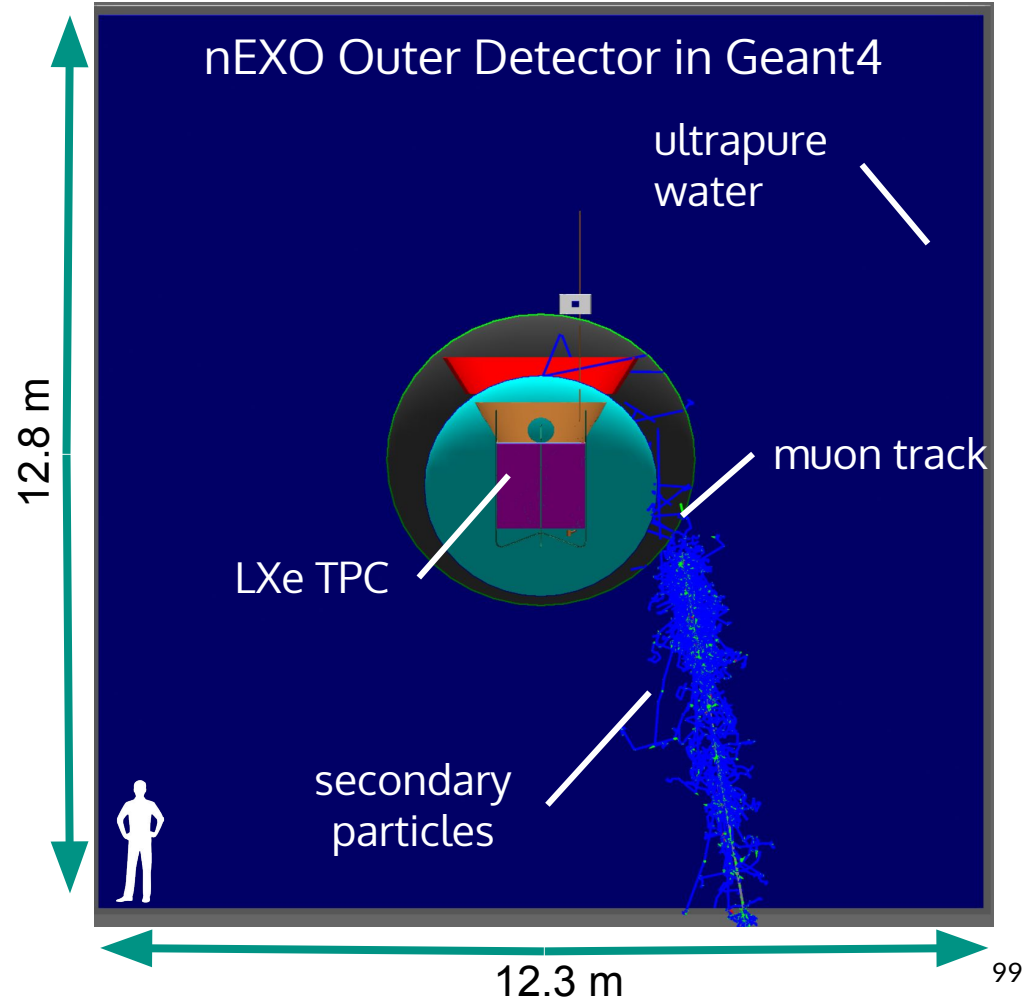

Cosmogenic activation rates

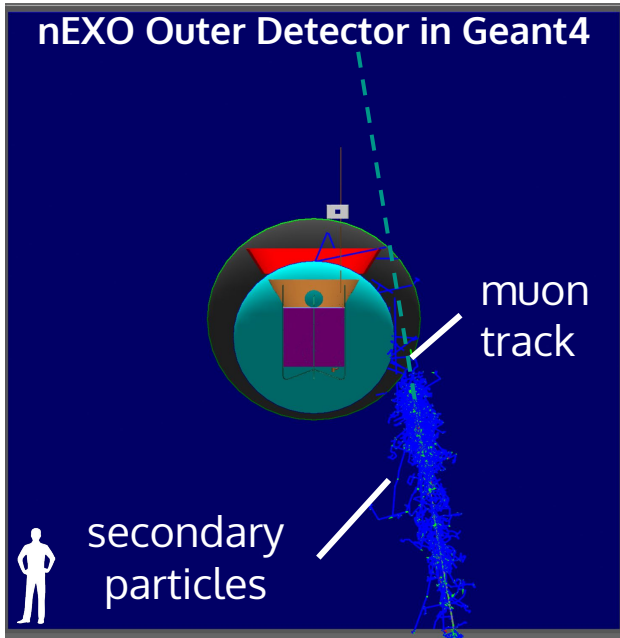

Cosmogenic activation rates

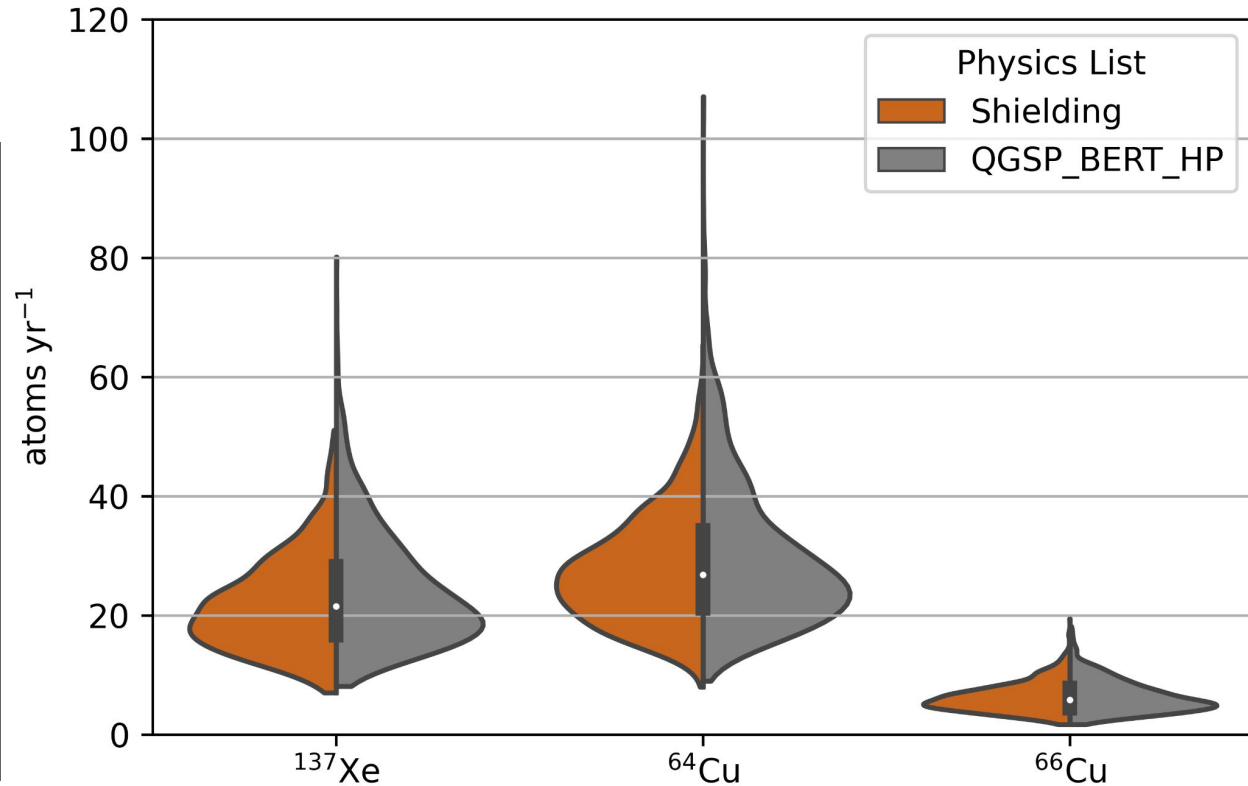
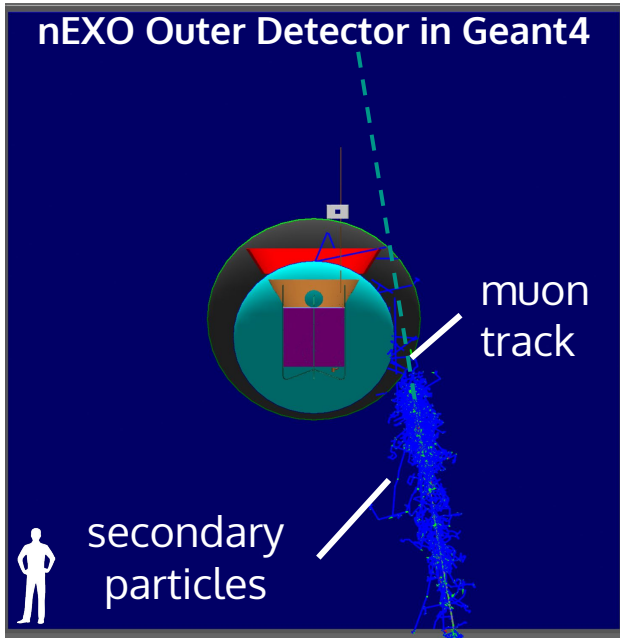

Low impact parameter \rightarrow more background production

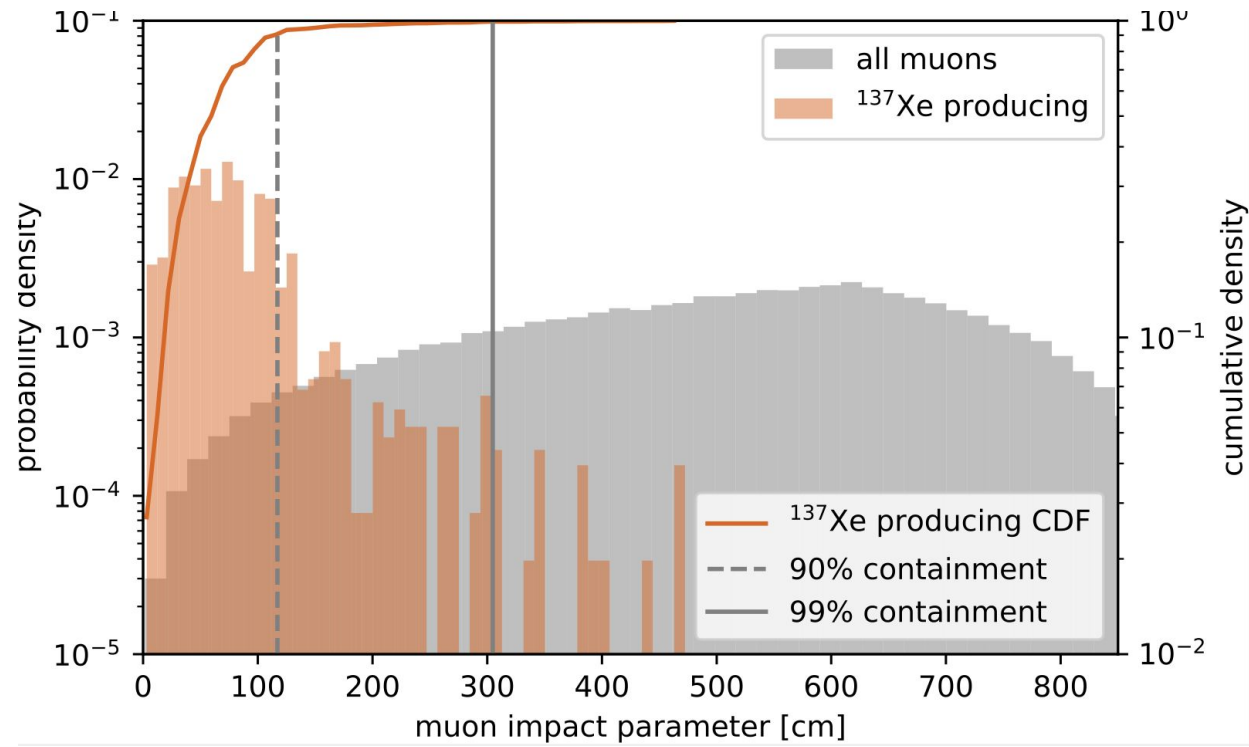
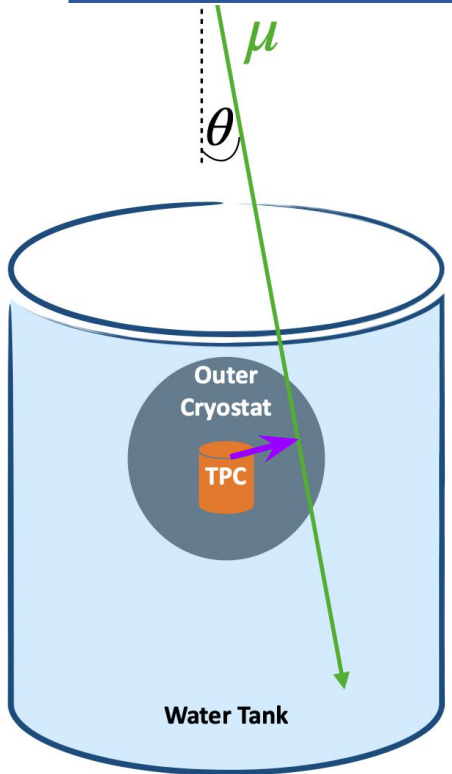

$^{136}\text{Xe}(n, \gamma)^{137}\text{Xe}$ tagging

1. $\mu^\pm \rightarrow \pi^\pm + p + n + \dots$

... neutron thermalization ~ 100 's μs ...

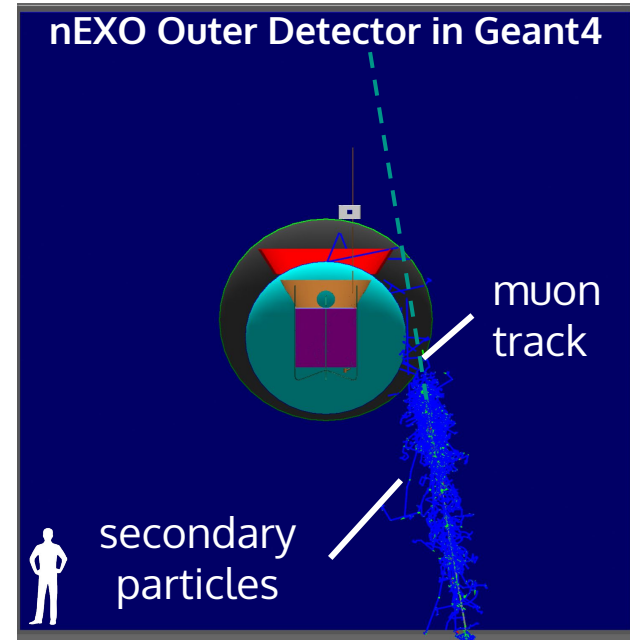

$^{136}\text{Xe}(n, \gamma)^{137}\text{Xe}$ tagging

1. $\mu^\pm \rightarrow \pi^\pm + p + n + \dots$

... neutron thermalization ~ 100 's μs ...



Can we tag this?

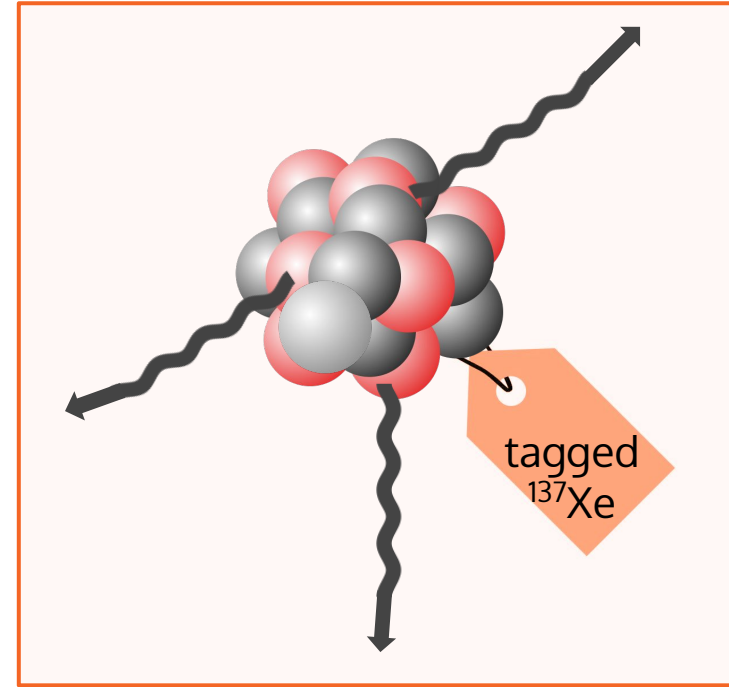

$^{136}\text{Xe}(n, \gamma)^{137}\text{Xe}$ tagging

1. $\mu^\pm \rightarrow \pi^\pm + p + n + \dots$

... neutron thermalization ~ 100 's μs ...



... β -decay half-life ~ 3.8 minutes



... and veto the following \sim few half lives of ^{137}Xe from the low-background dataset?

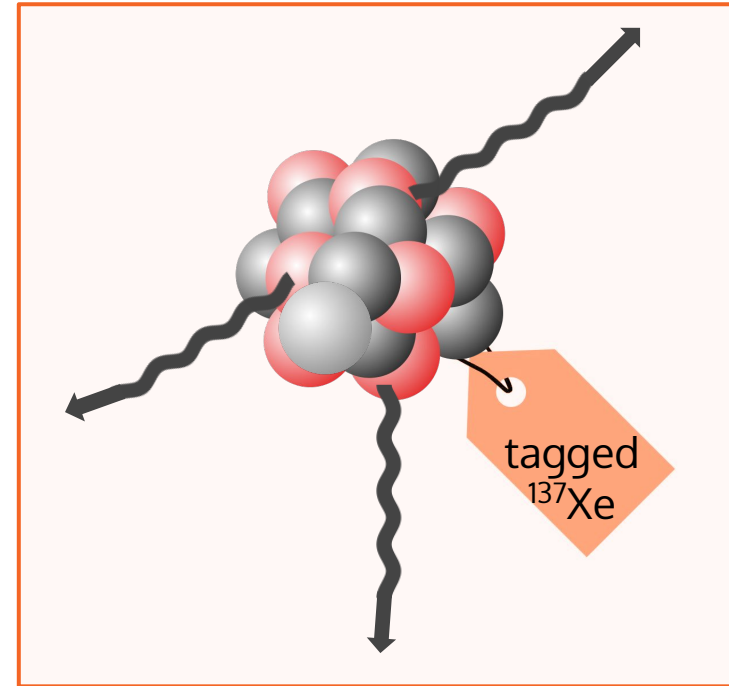

Proposed nEXO ^{137}Xe light-only TPC tag

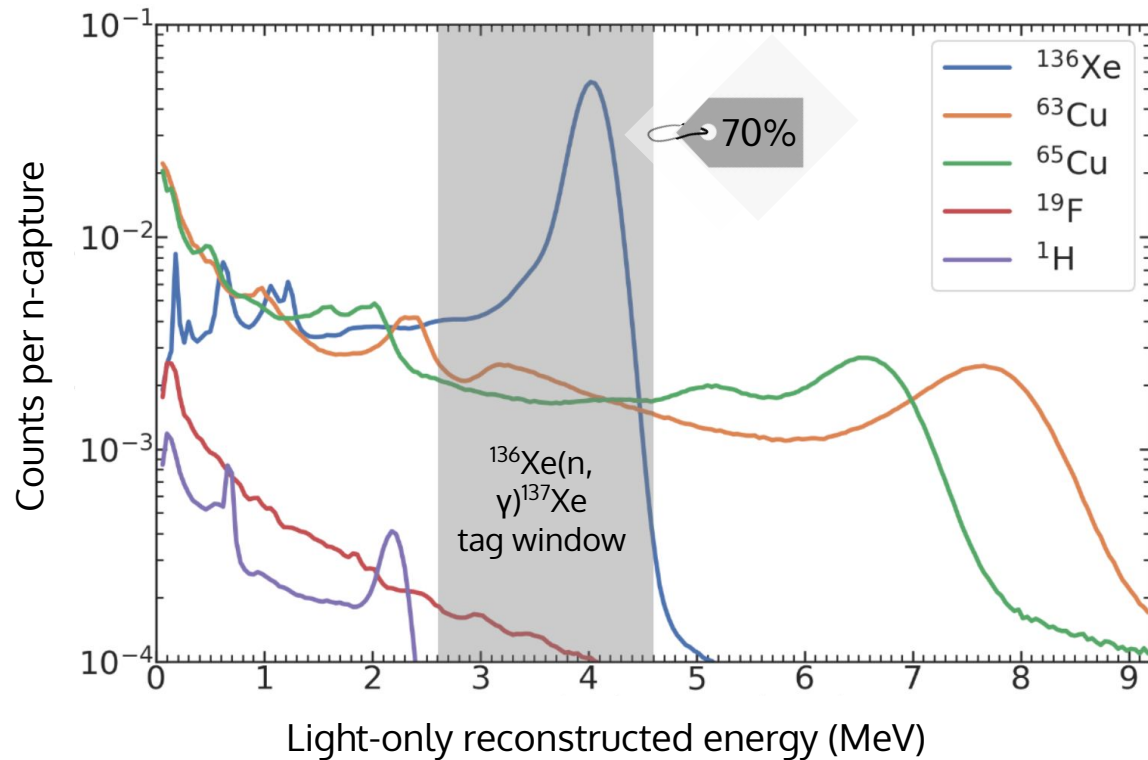
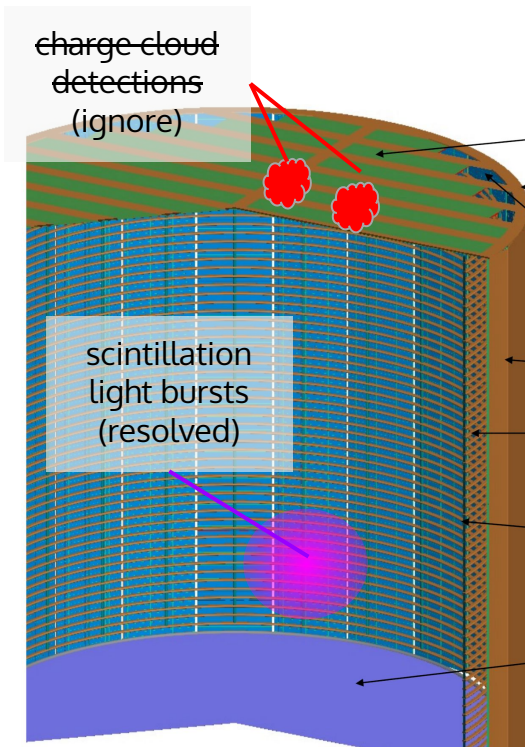

Sensitivity variation with ^{137}Xe background

Data published:

[G Adhikari et al 2022](#)

[J. Phys. G: Nucl. Part. Phys. 49 015104](#)

[DOI 10.1088/1361-6471/ac3631](#)

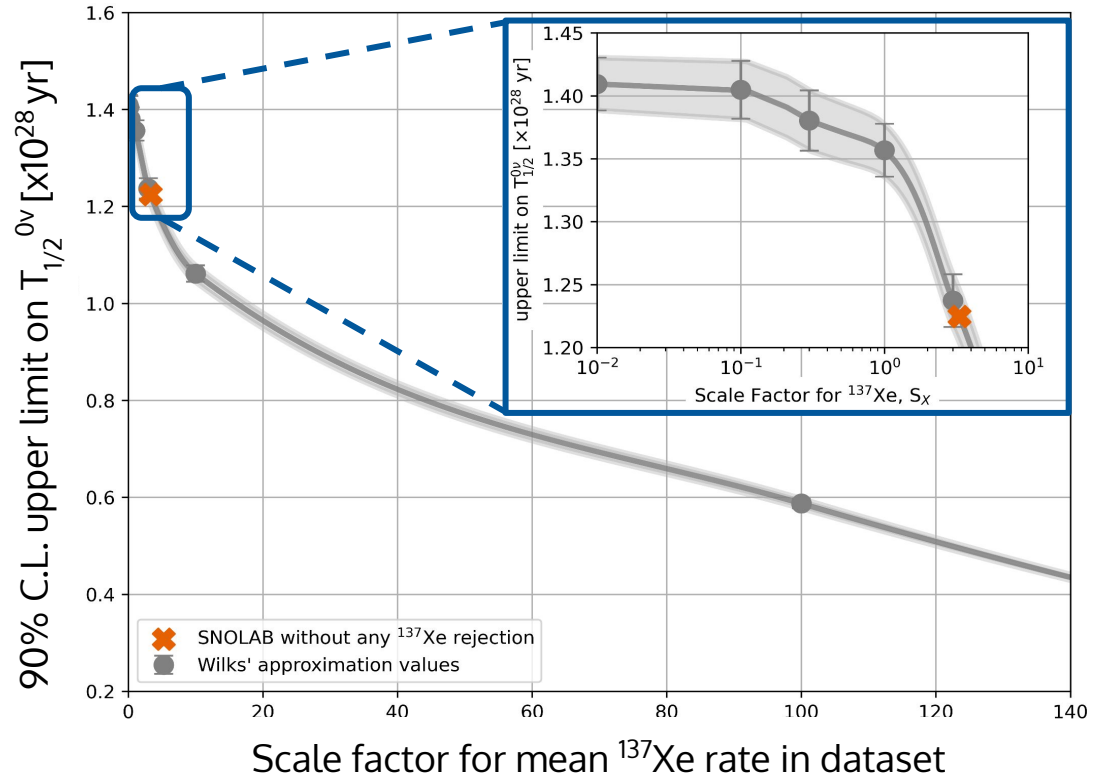

nEXO's sensitivity scaling with livetime (exposure)

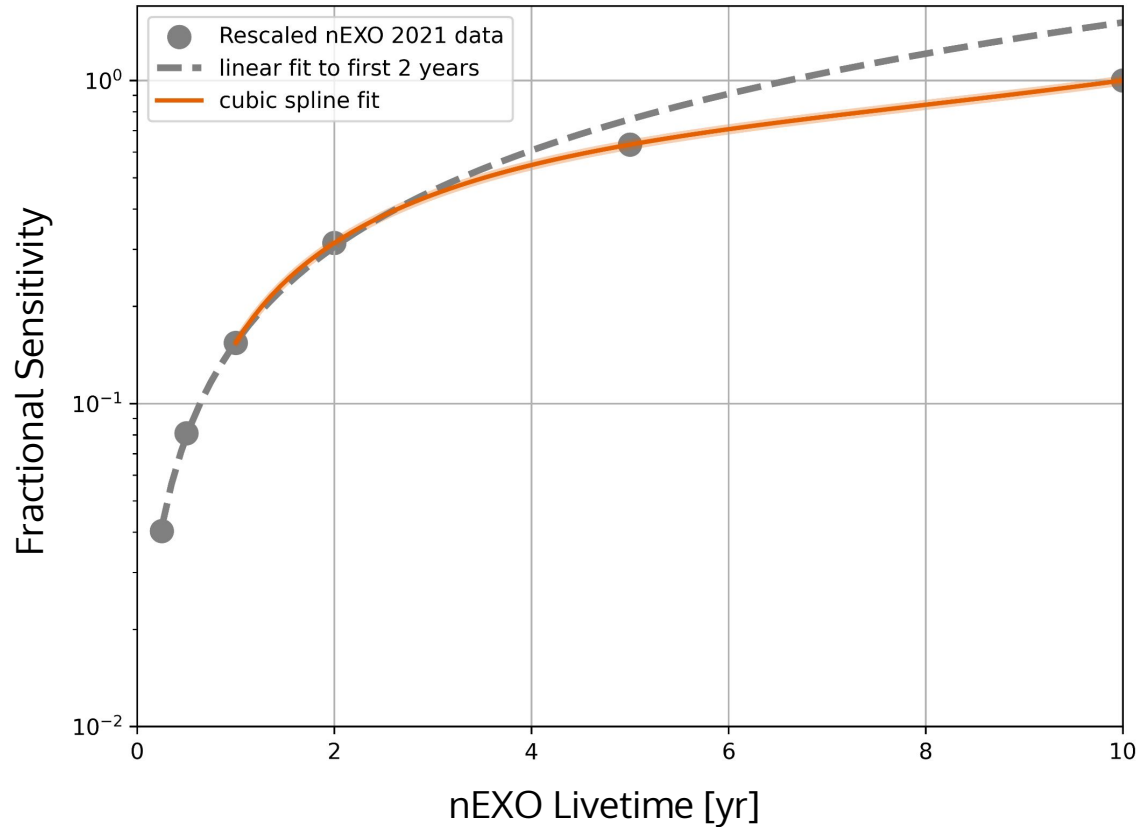

Sensitivity gain vs muon veto length

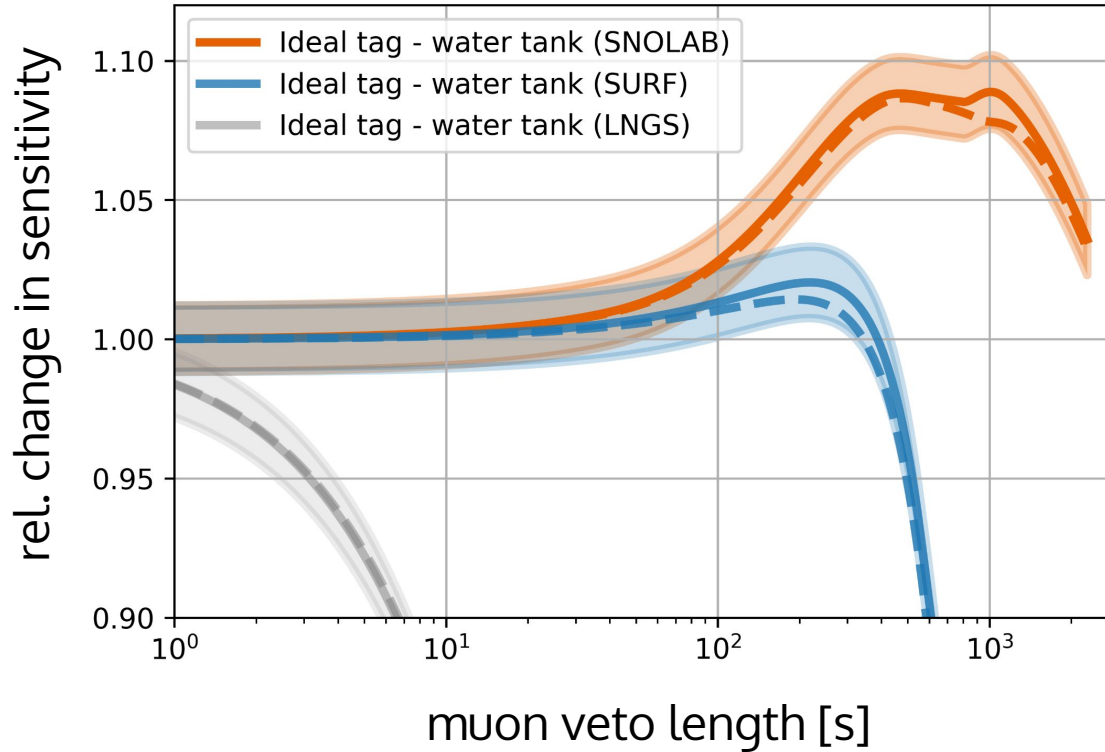

Underground site selection

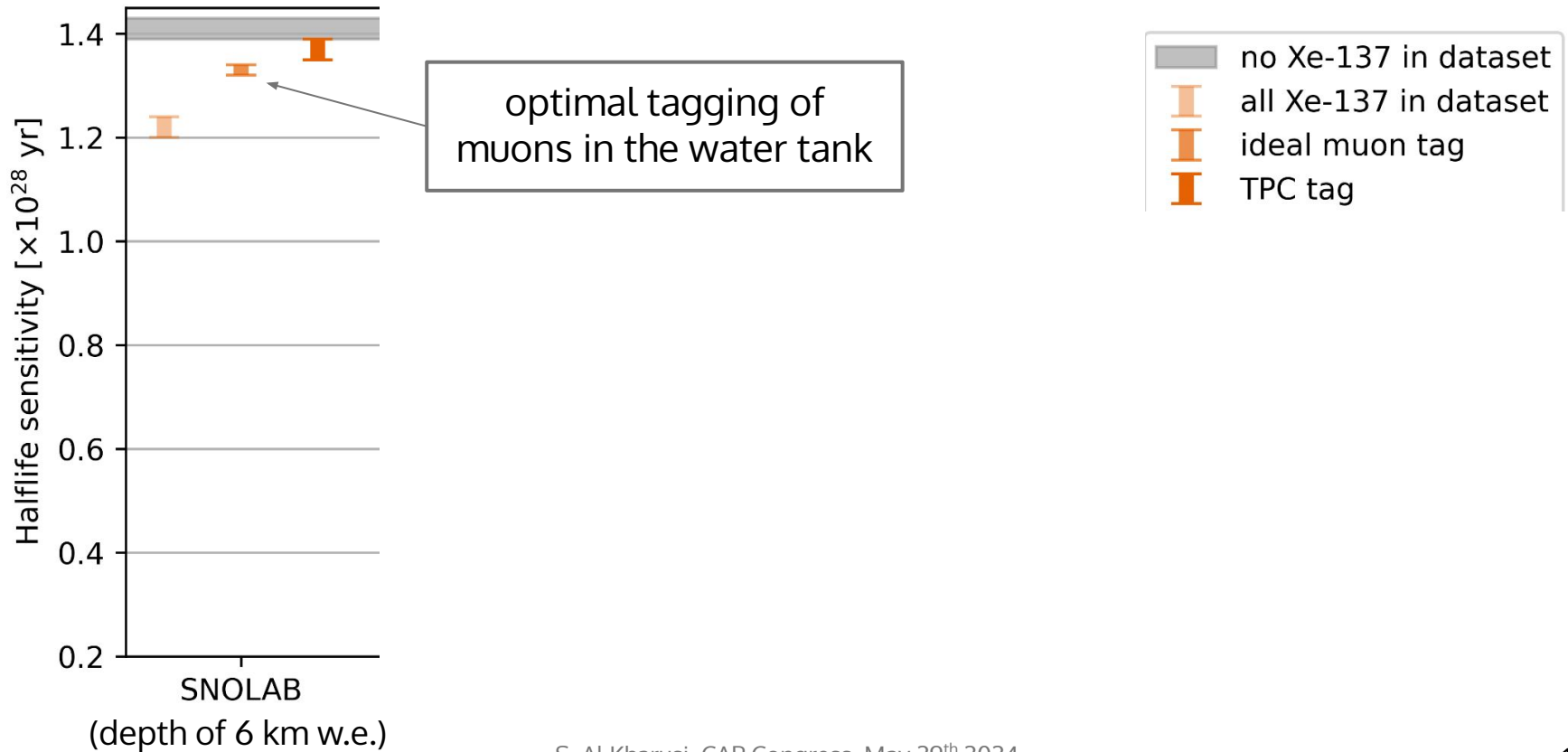

Underground site selection

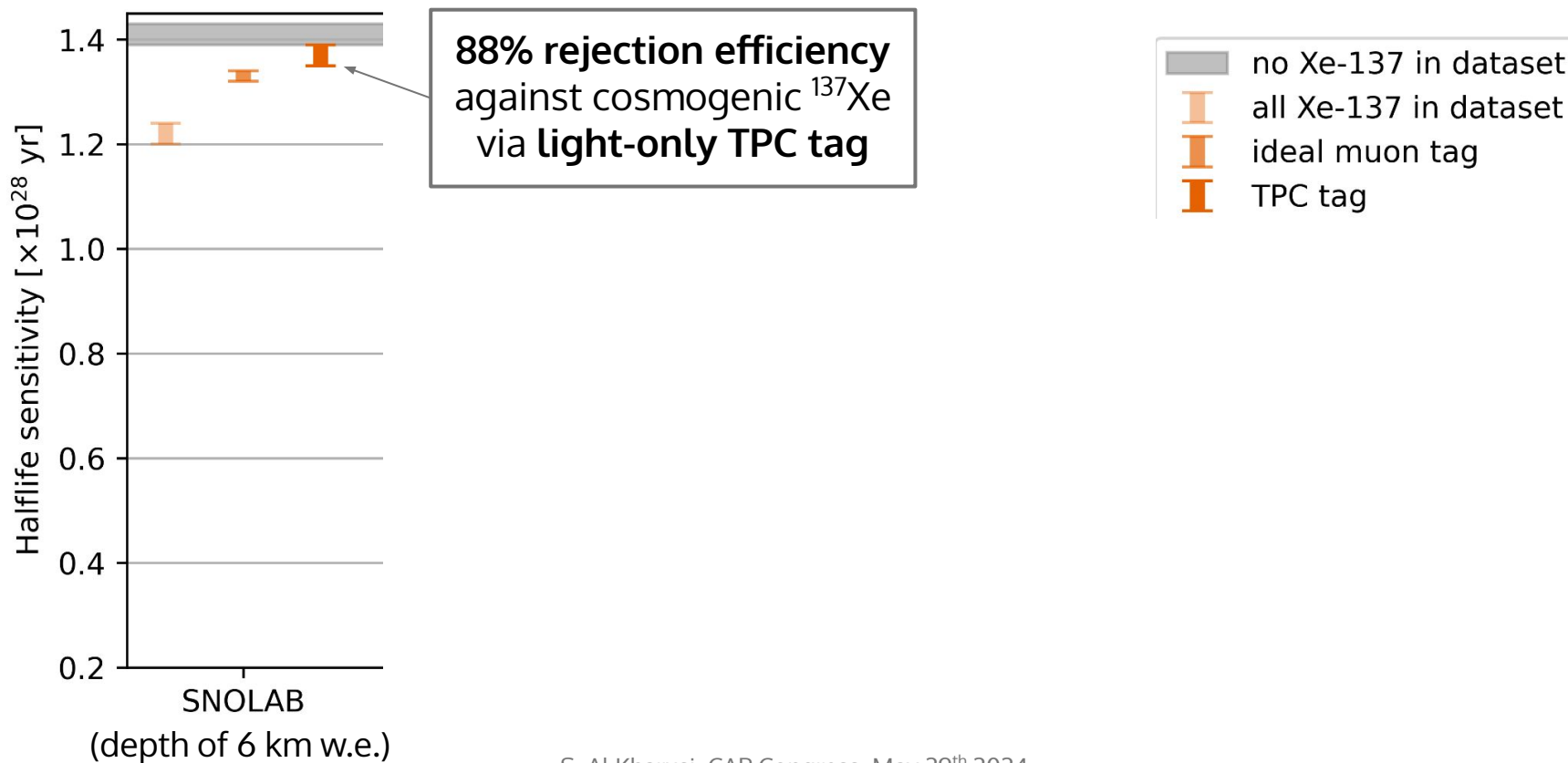

Underground site selection

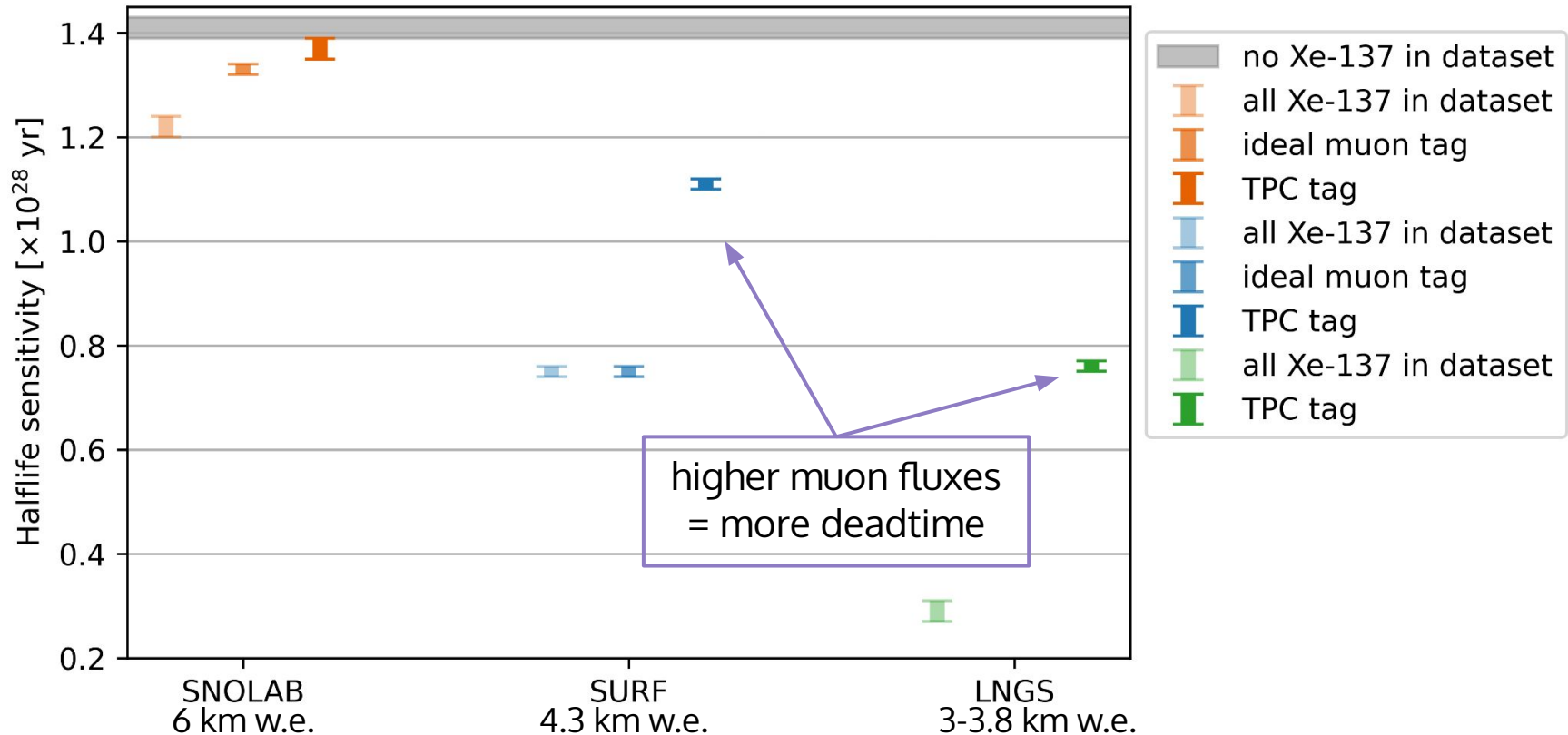



nEXO requires a 1.4 kt **water tank to shield the xenon** from neutron & γ -radiation

muons passing through the water will **produce Cherenkov light** detectable with PMTs

How many PMTs do we need & where should we place them?

water-Cherenkov Muon Veto → nEXO Outer Detector (OD)

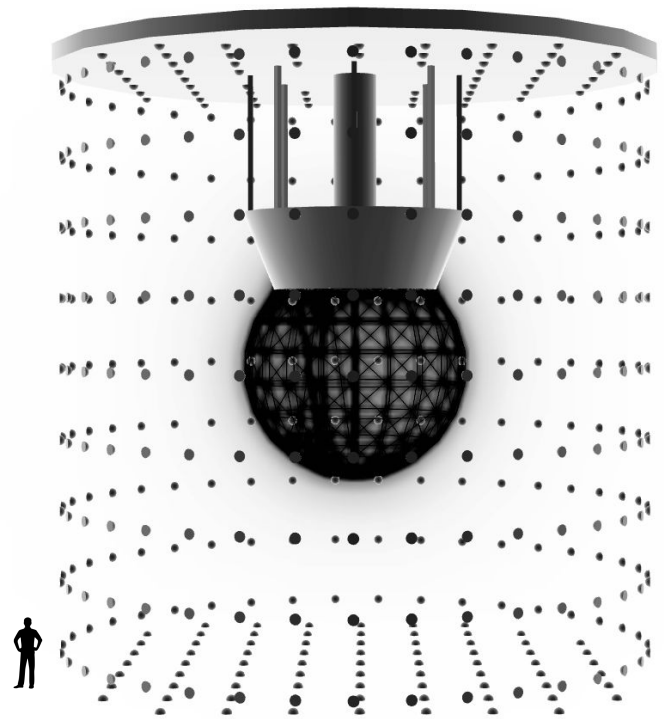

Geant4 (CPU-based, established)

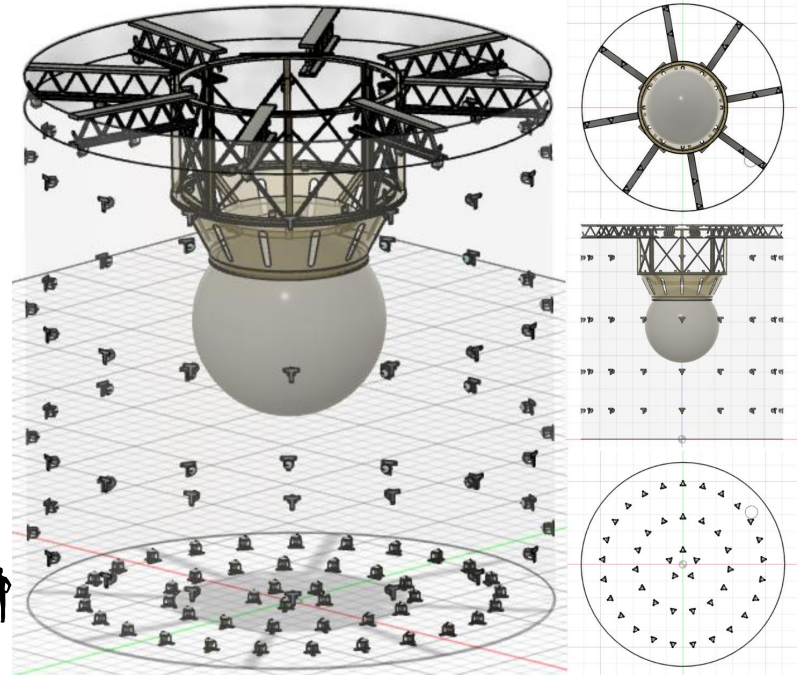

Chroma (GPU-based, first-principles)

Defining the muon trigger

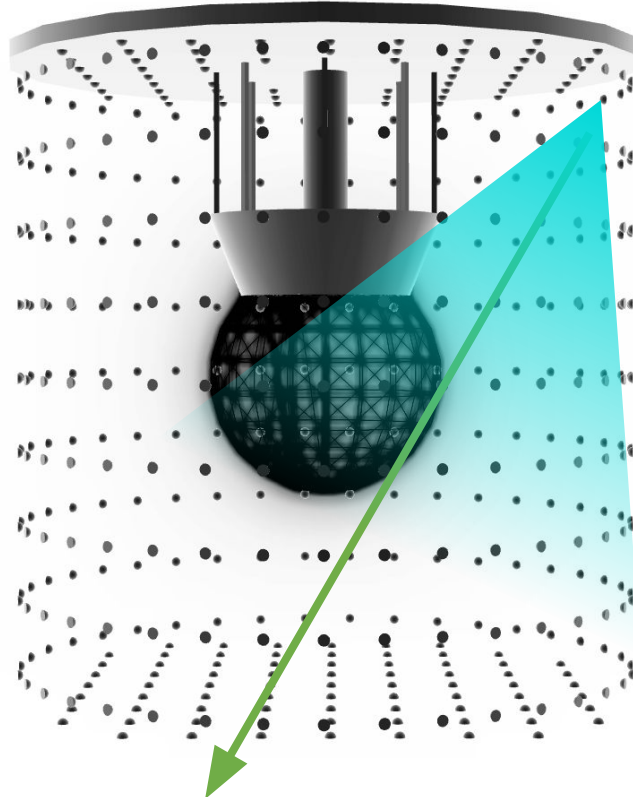

Defining the muon trigger

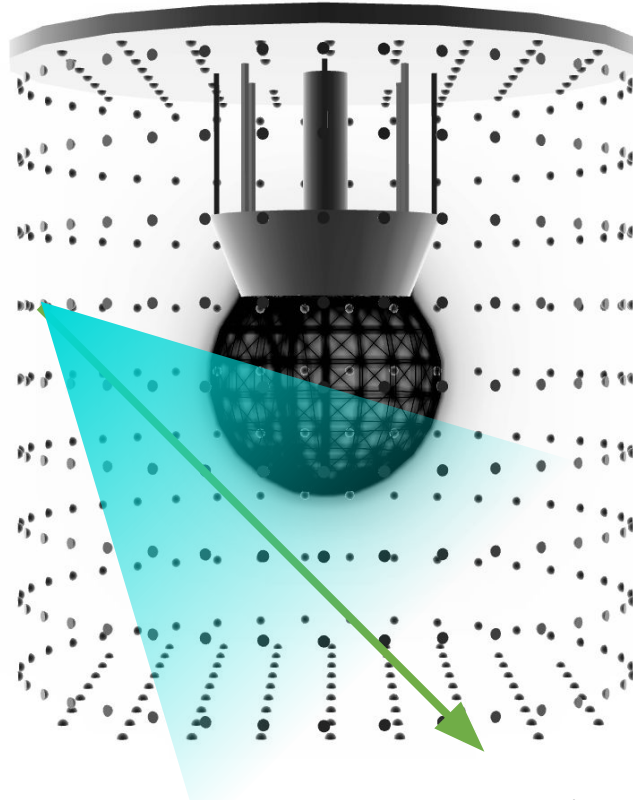

Muon trigger condition

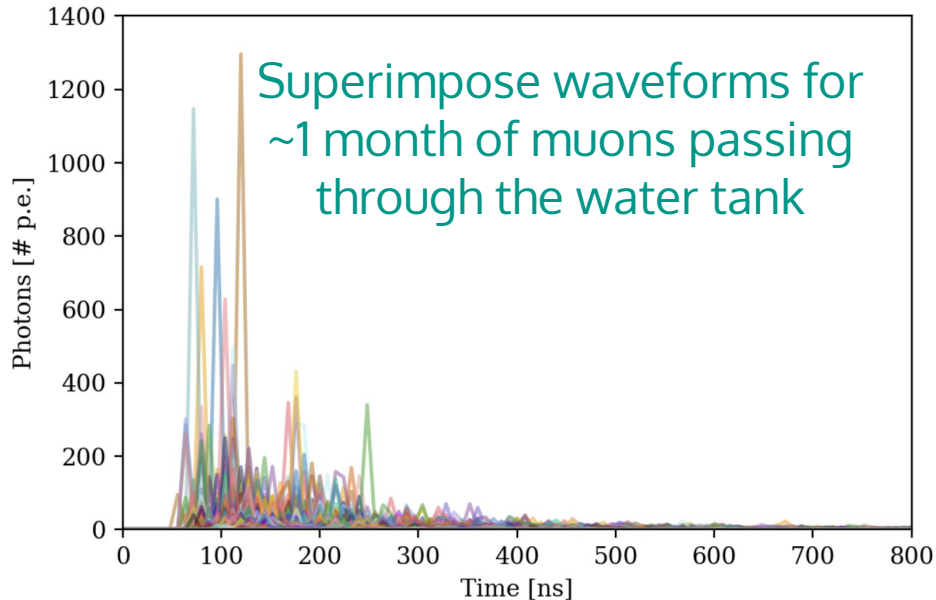

NB:

- Waveforms generated after quantum efficiency correction
- Photon hit times binned to 8 ns (CAEN VX2740 digitizer)

Muon trigger condition

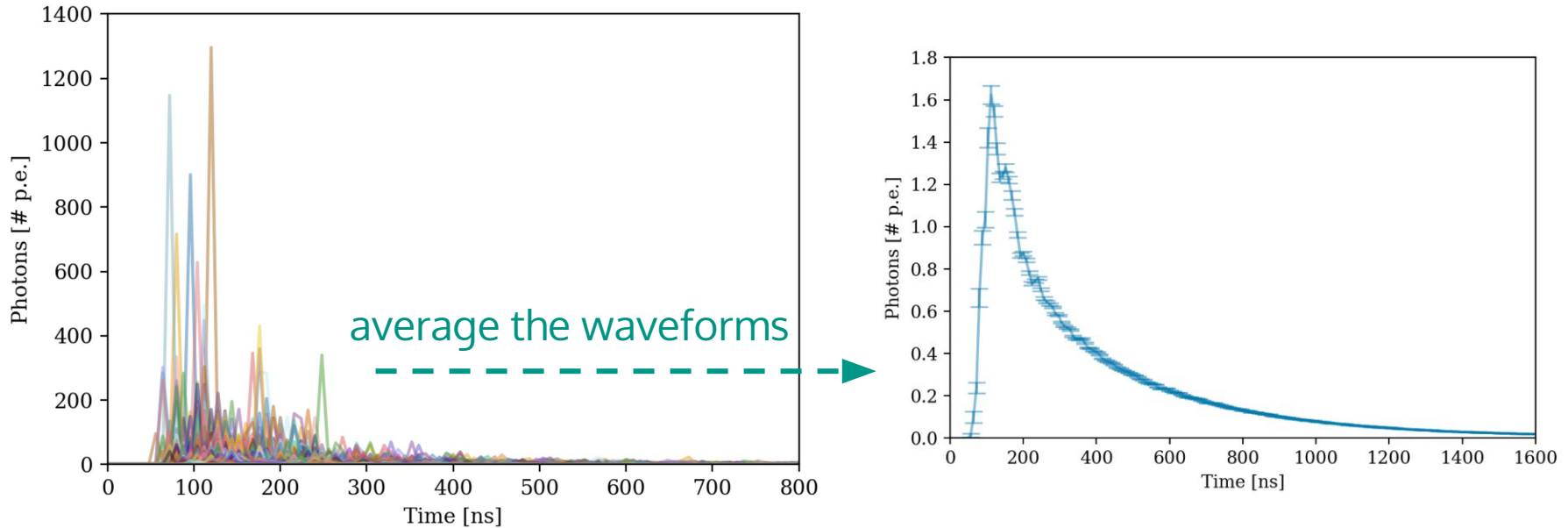

NB:

- Waveforms generated after quantum efficiency correction
- Photon hit times binned to 8 ns (CAEN VX2740 digitizer)

Muon trigger condition

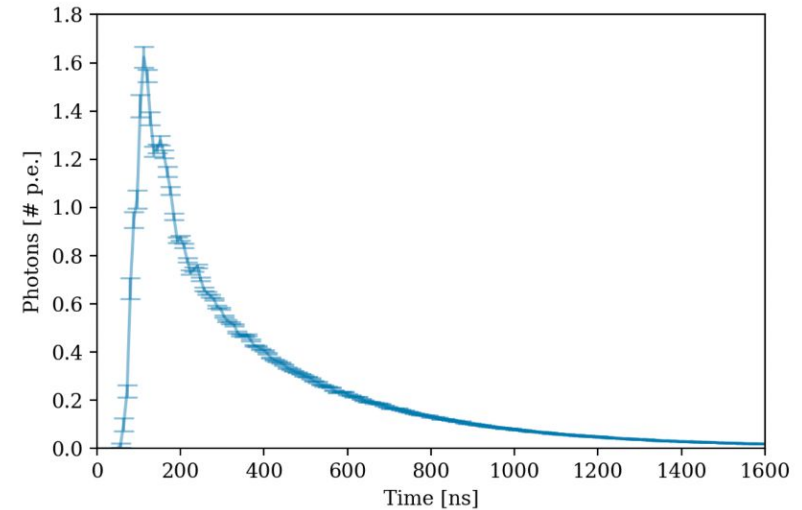
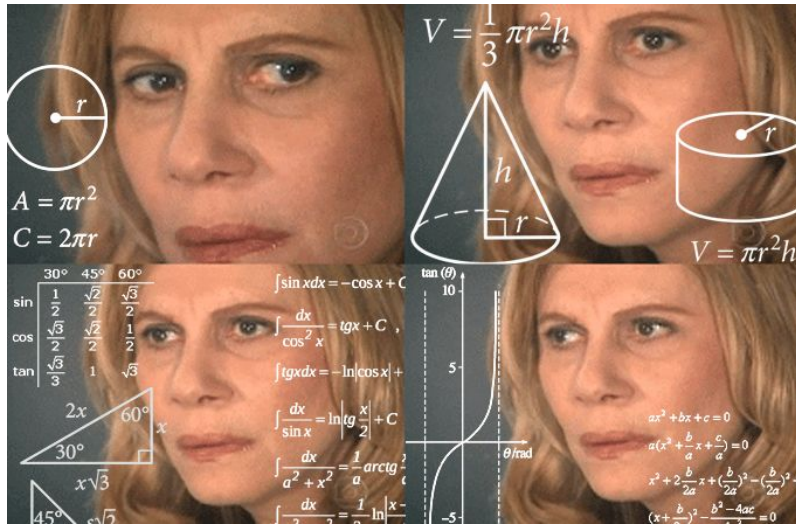

NB:

- Waveforms generated after quantum efficiency correction
- Photon hit times binned to 8 ns (CAEN VX2740 digitizer)

Muon trigger condition

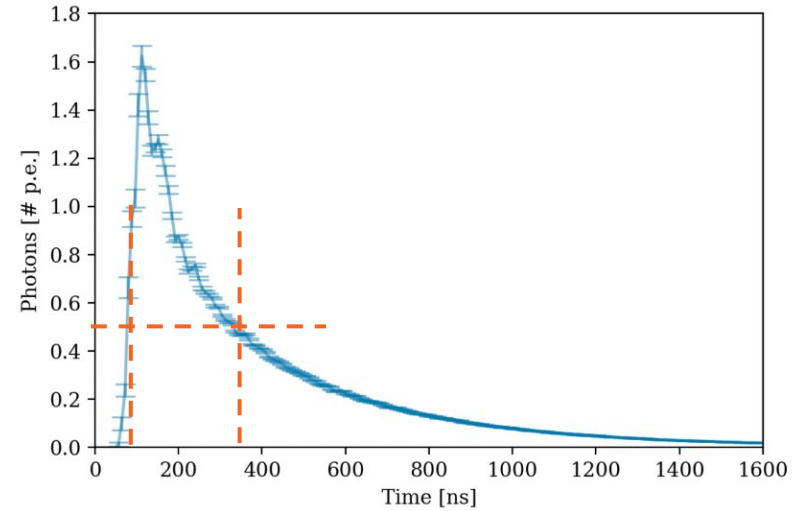
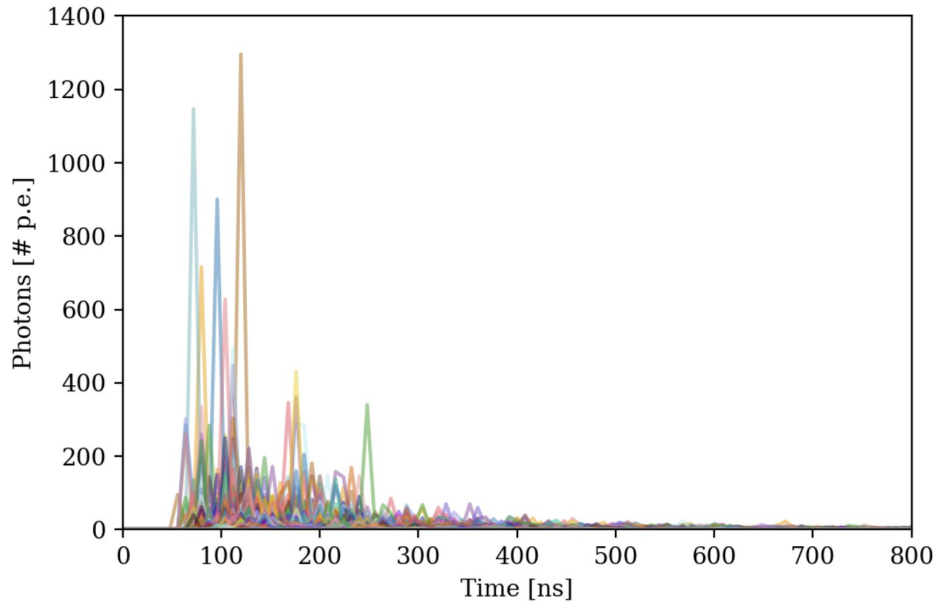

“Trigger at the single photoelectron level in a 240 ns coincidence window”

Muon light map

~1/2 the light lands on the floor

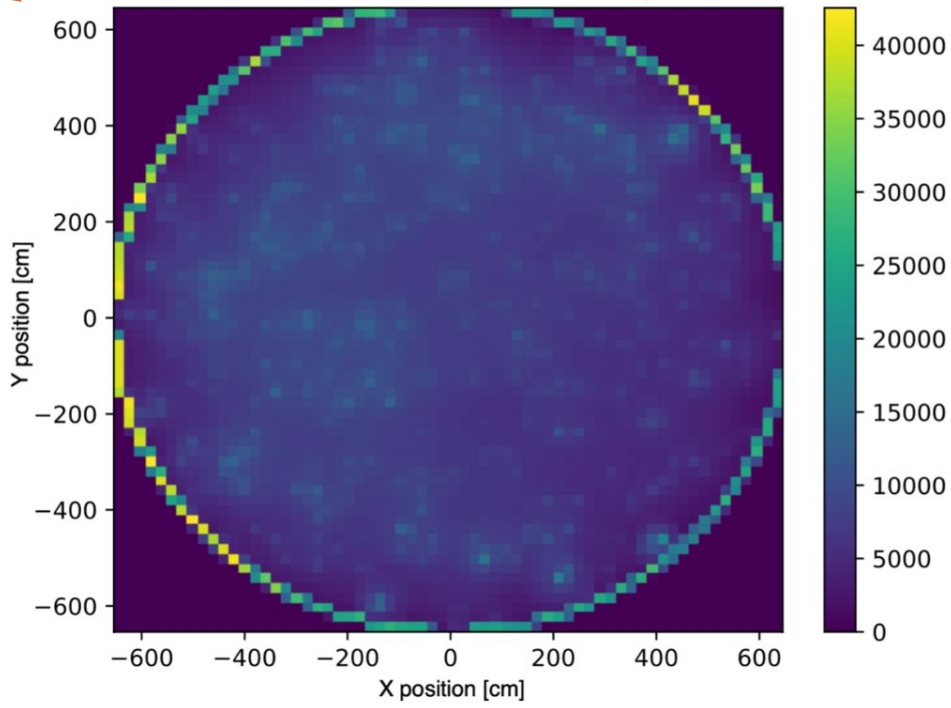
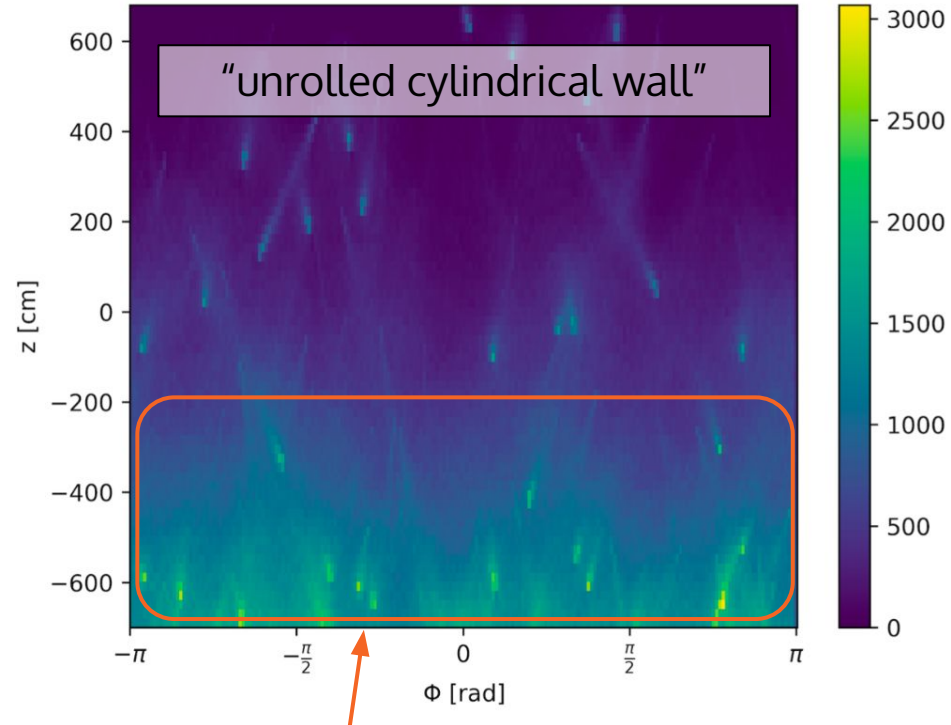

bottom 1/3 of water tank receives 40% of light

PMT layout (125 PMTs)

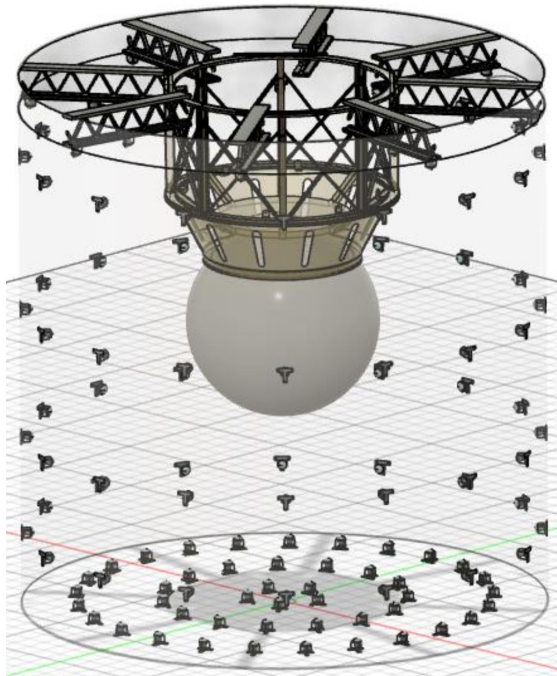

Chroma

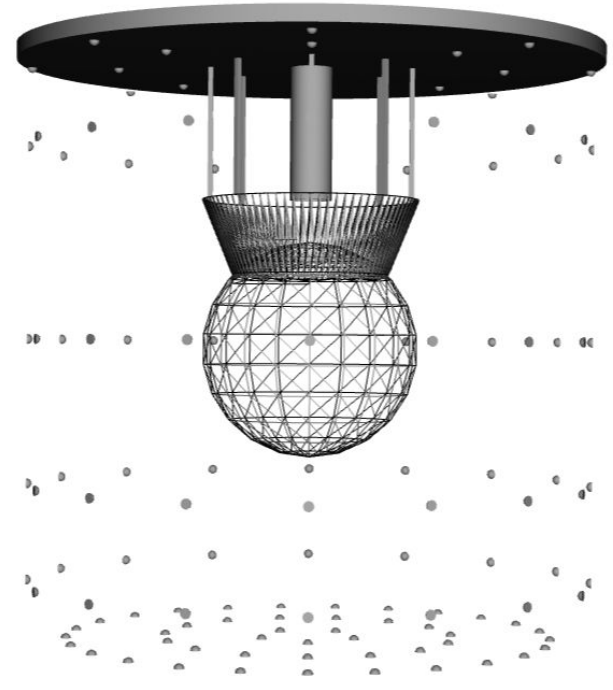
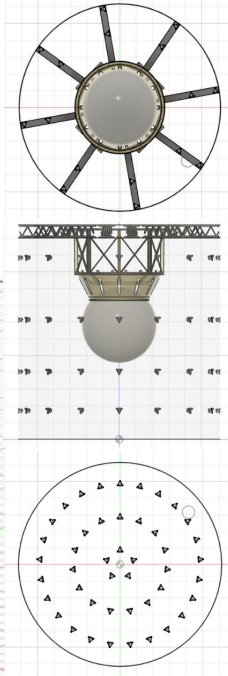

Geant4

Geant4 Results: OD muon tagging

Muon tag and ^{137}Xe activation can be associated >95% of the time

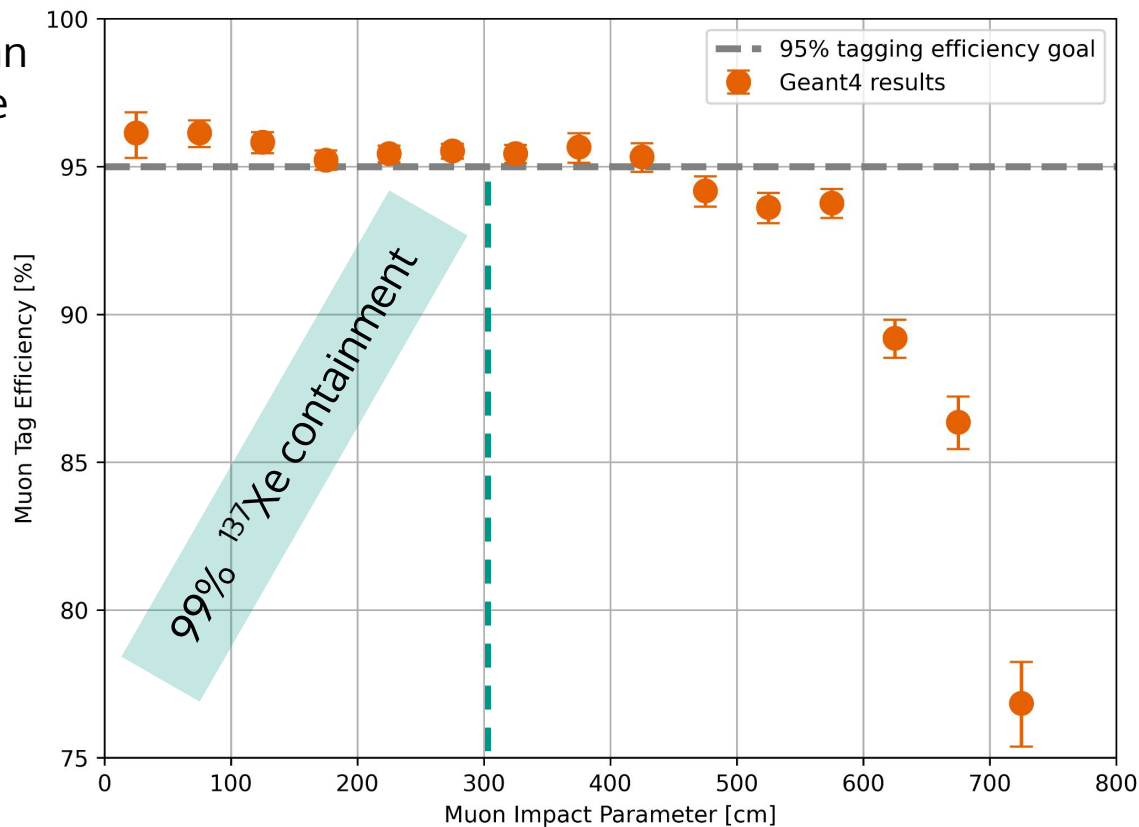



Multi-messenger astronomy is a rapidly
growing field

nEXO is an **ultra-low background** experiment
optimized for **MeV-scale interactions**

Is nEXO sensitive to neutrinos
from core-collapse supernovae?

A star is born dying



S. Al Kharusi, CAP Congress, May 29th 2024

Core-collapse supernovae (CCSN)



Gravitational Collapse

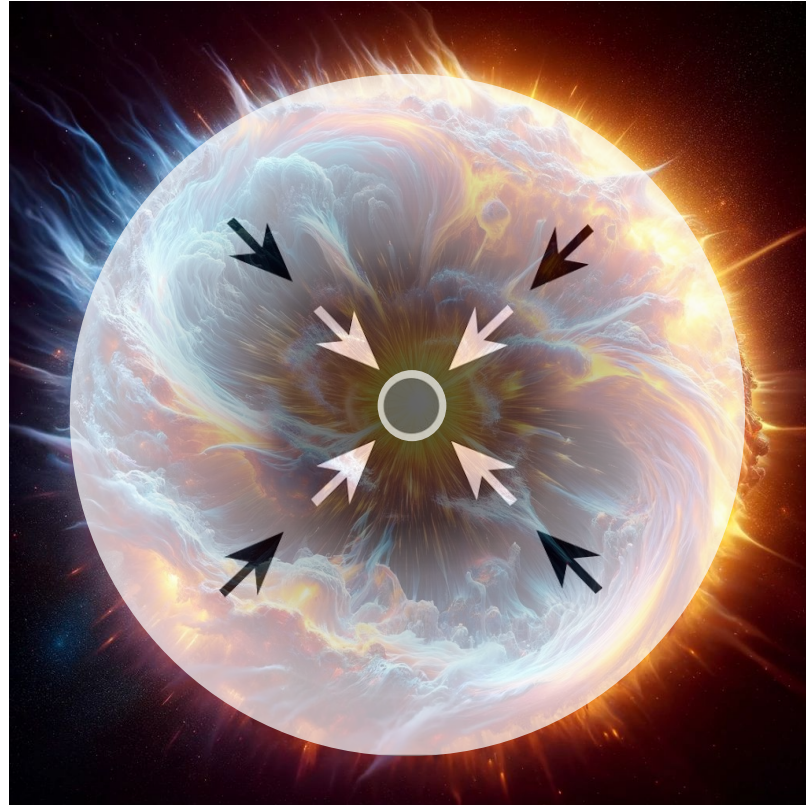

S. Al Kharusi, CAP Congress, May 29th 2024

Infall, rebound & shock

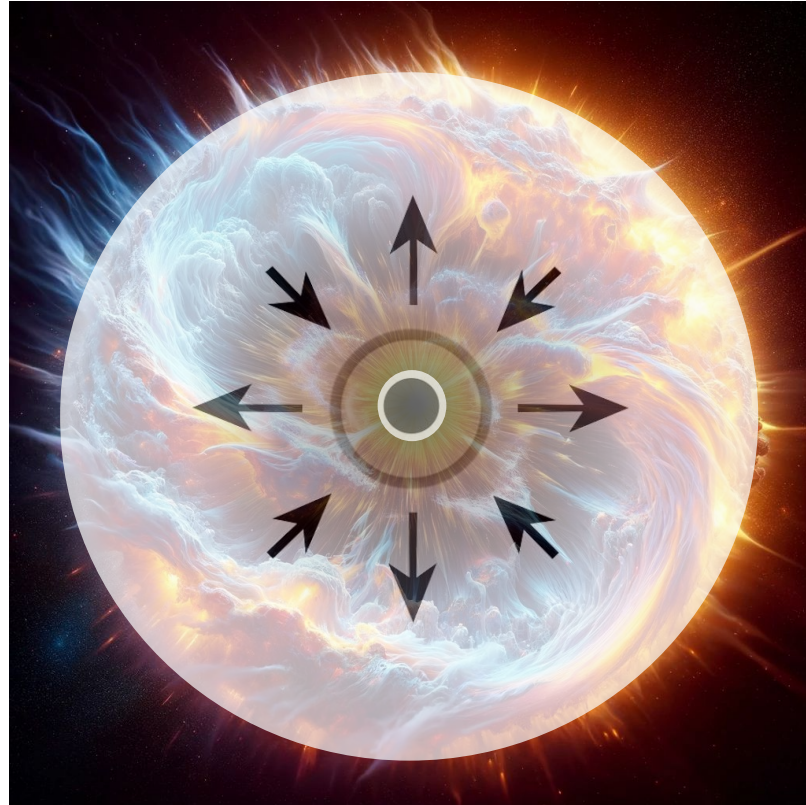

Shockwave stalling & v 's re-energizing

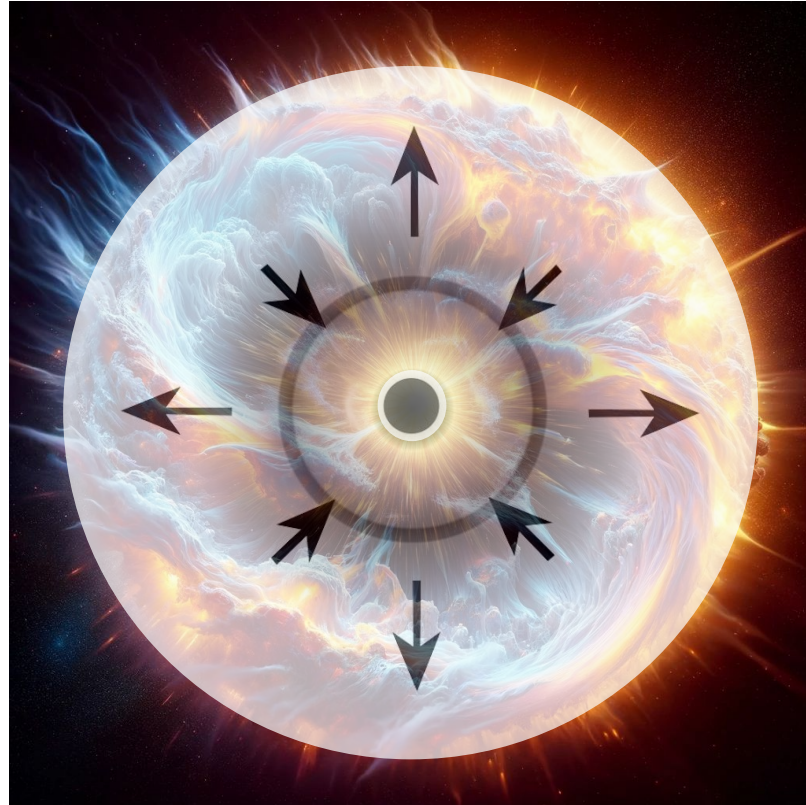

Shock breakout & explosion



S. Al Kharusi, CAP Congress, May 29th 2024

Shock breakout & explosion

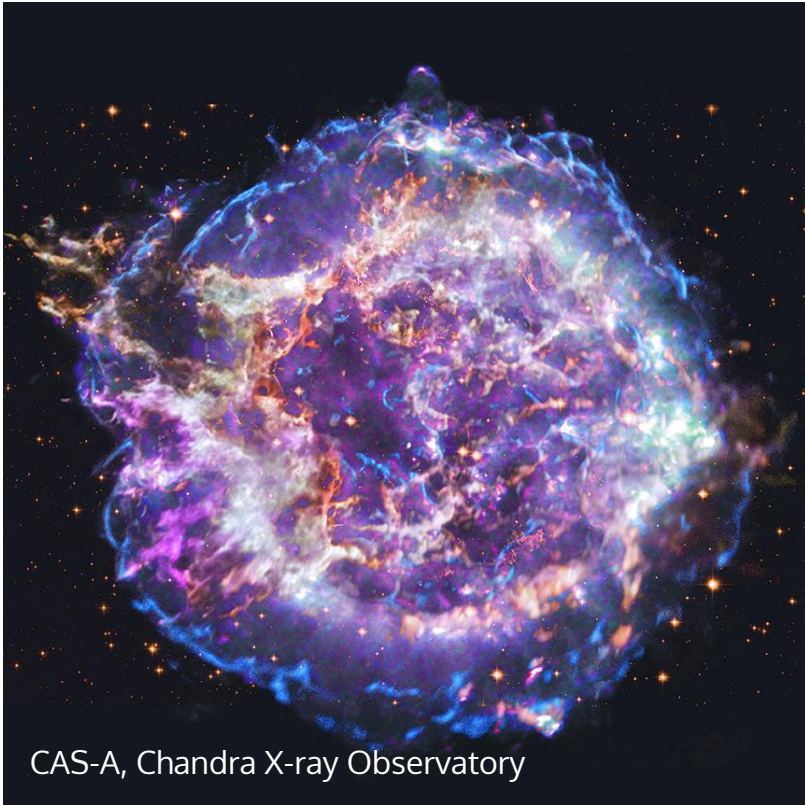

GVKM CCSN ν -Spectrum

ν -emission lasts ~ 10 s

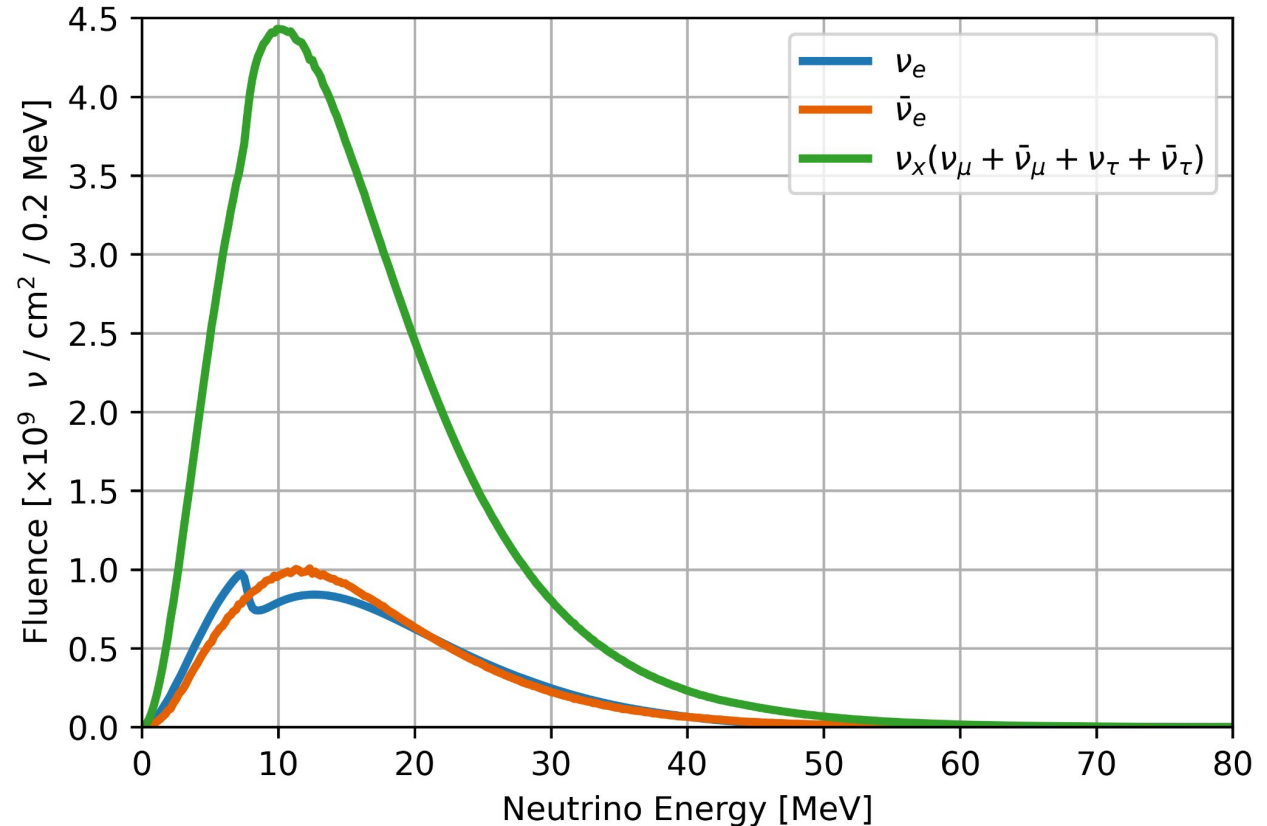

Inverse Beta Decay (IBD)

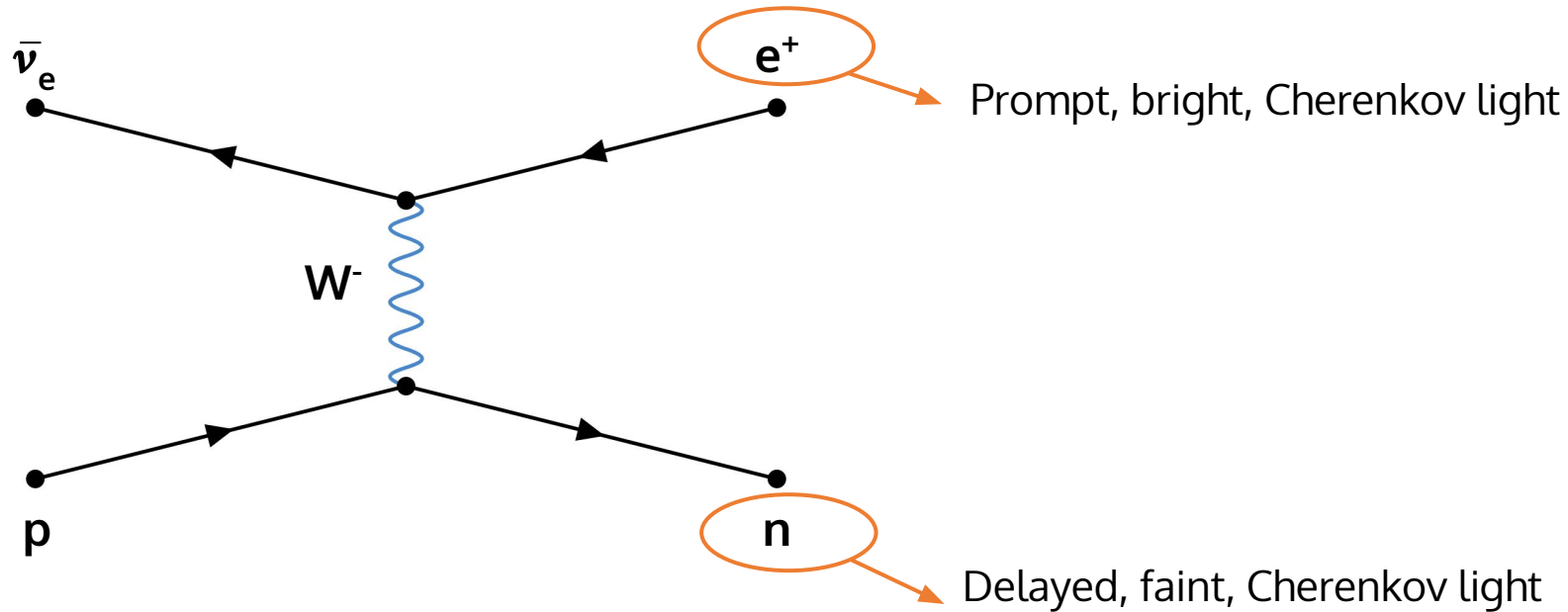

IBD event (on hydrogen in the water tank)

IBD Interaction rates in the water tank

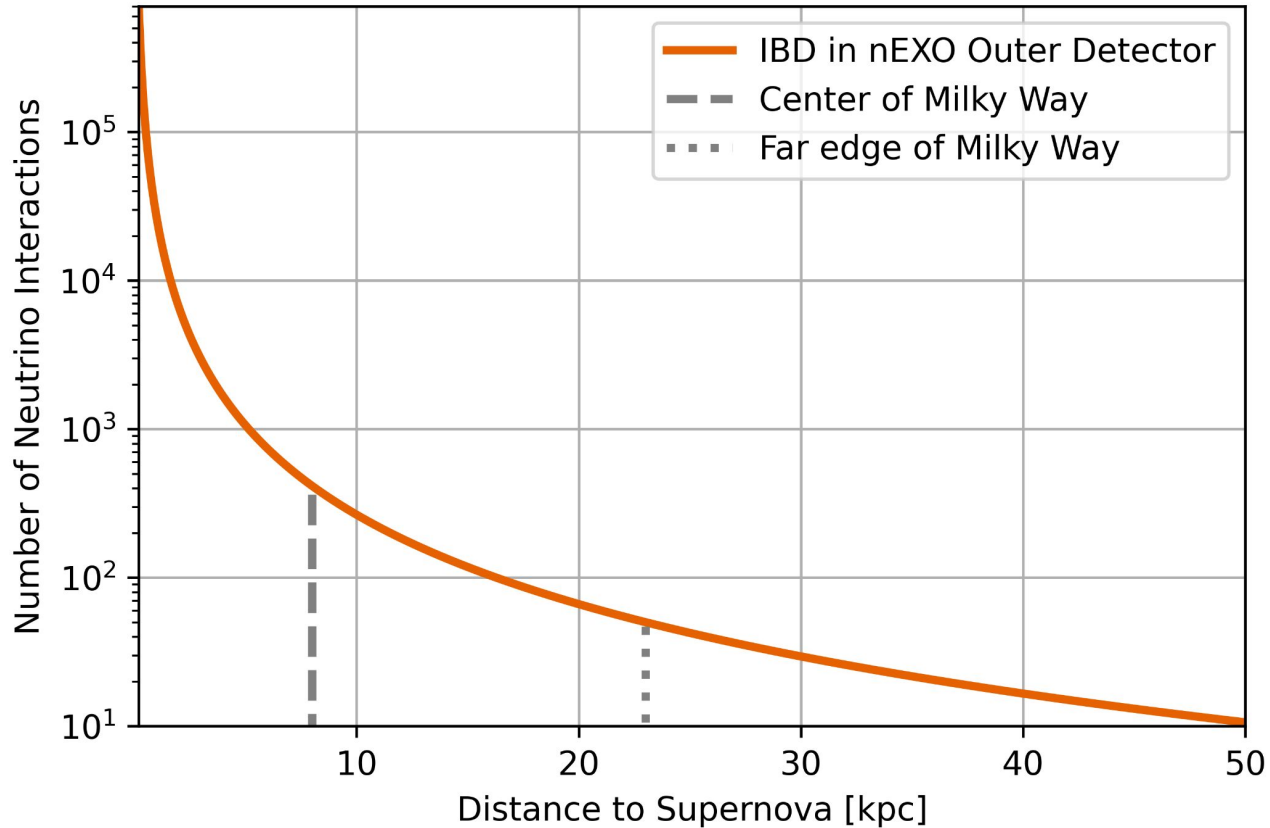

Positrons Triggering the Outer Detector

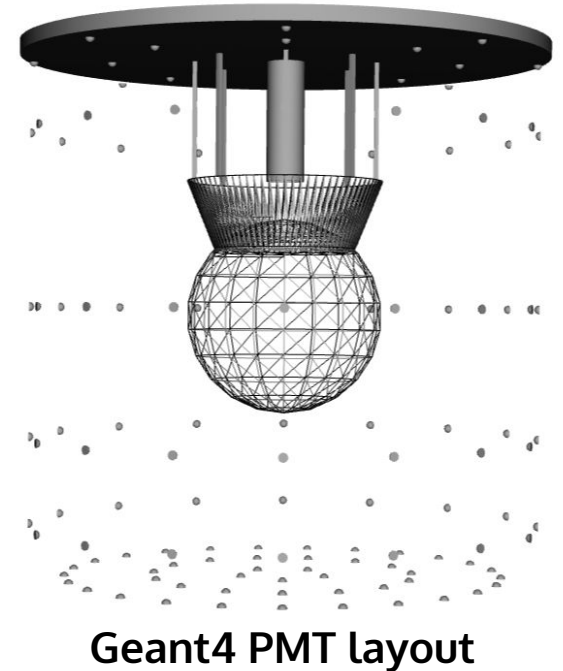
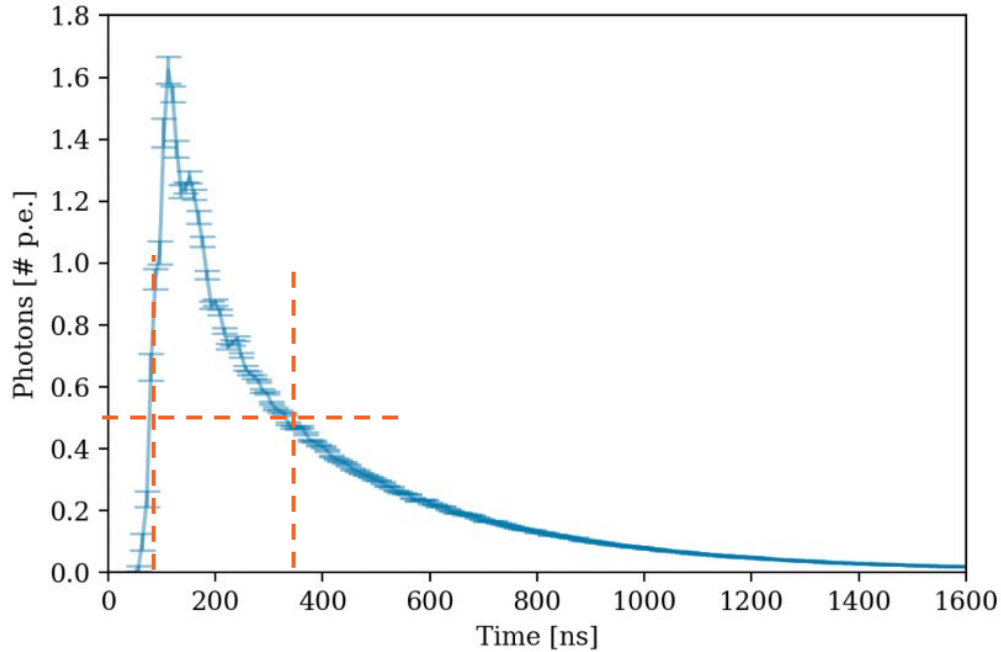

“Trigger on a 5-fold coincidence at s.p.e. level in a 240 ns window”

IBD Positron Tagging in the OD

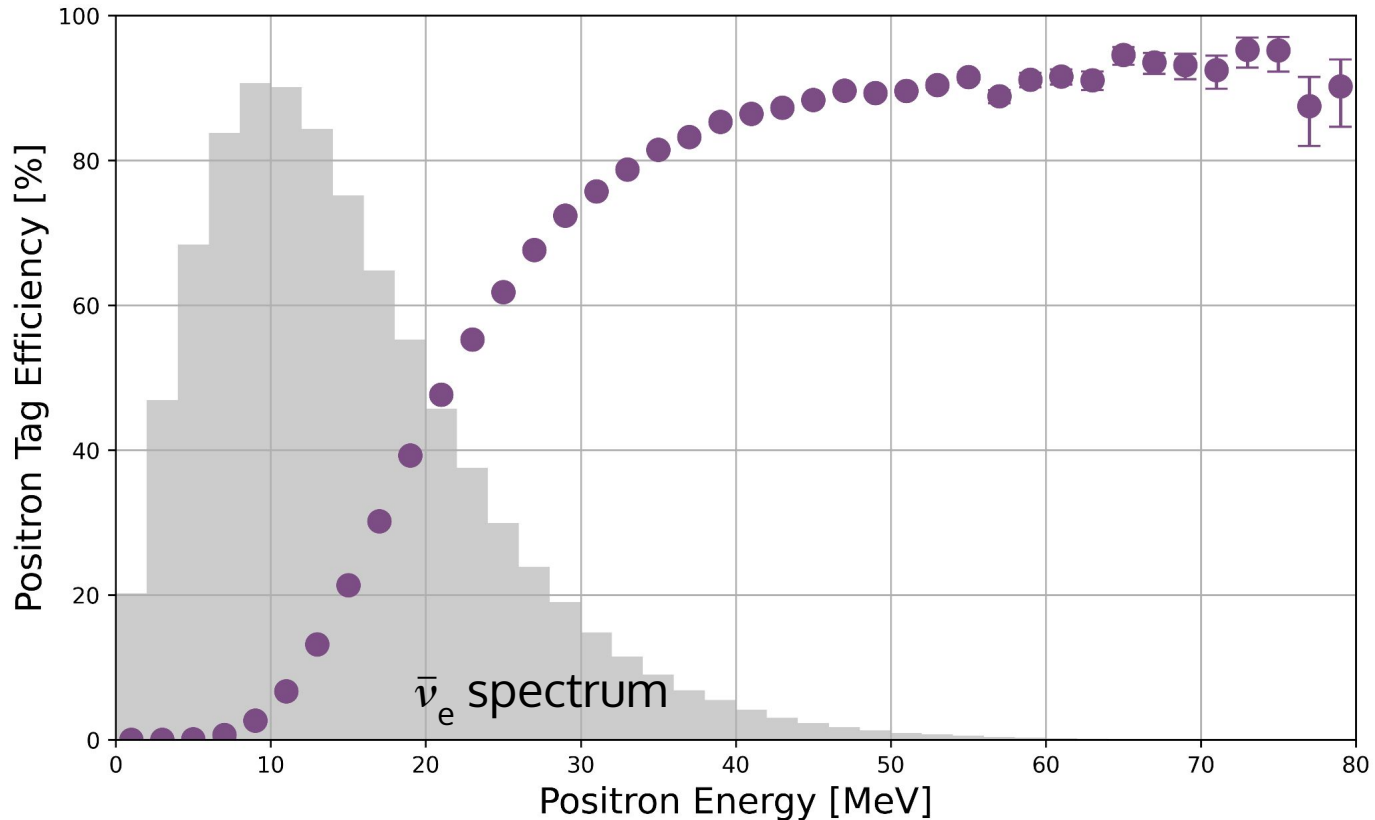

Positron light yields in the Outer Detector

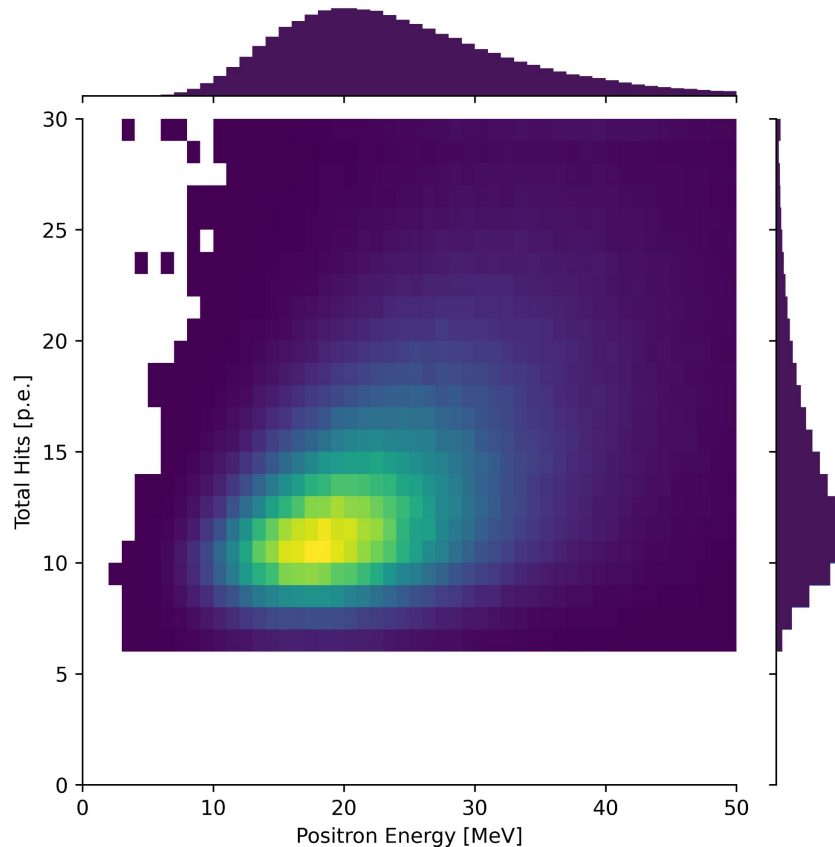

Positron light yields in the Outer Detector

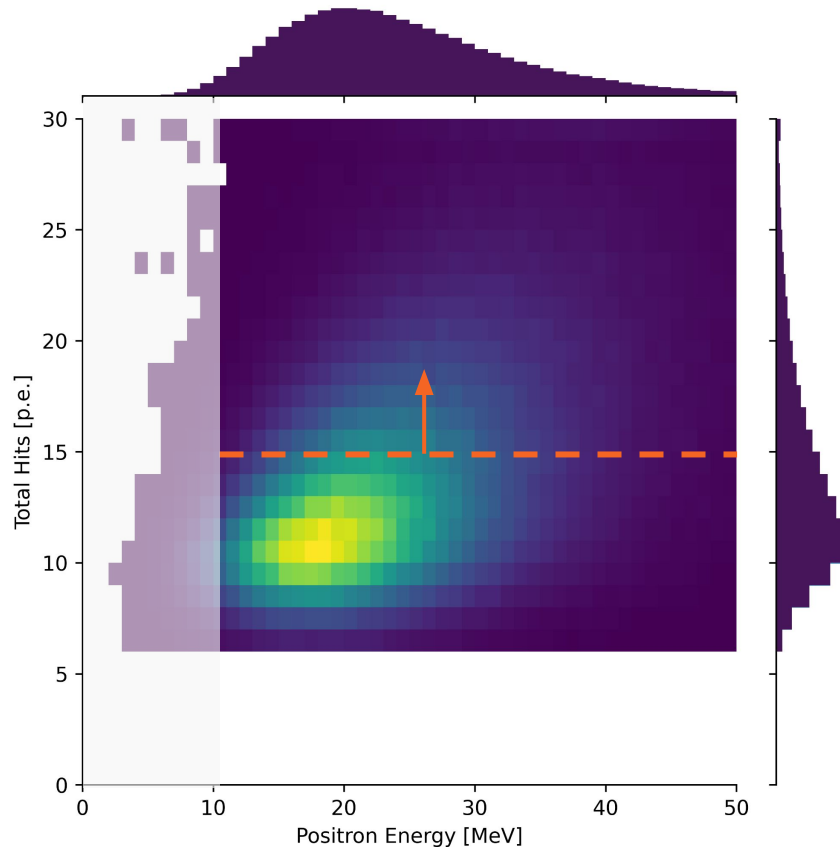

“How often do we see **>3 events** in the Outer Detector, each with **>15 p.e.** within **10 seconds?**”

GVKM burst detection in Outer Detector

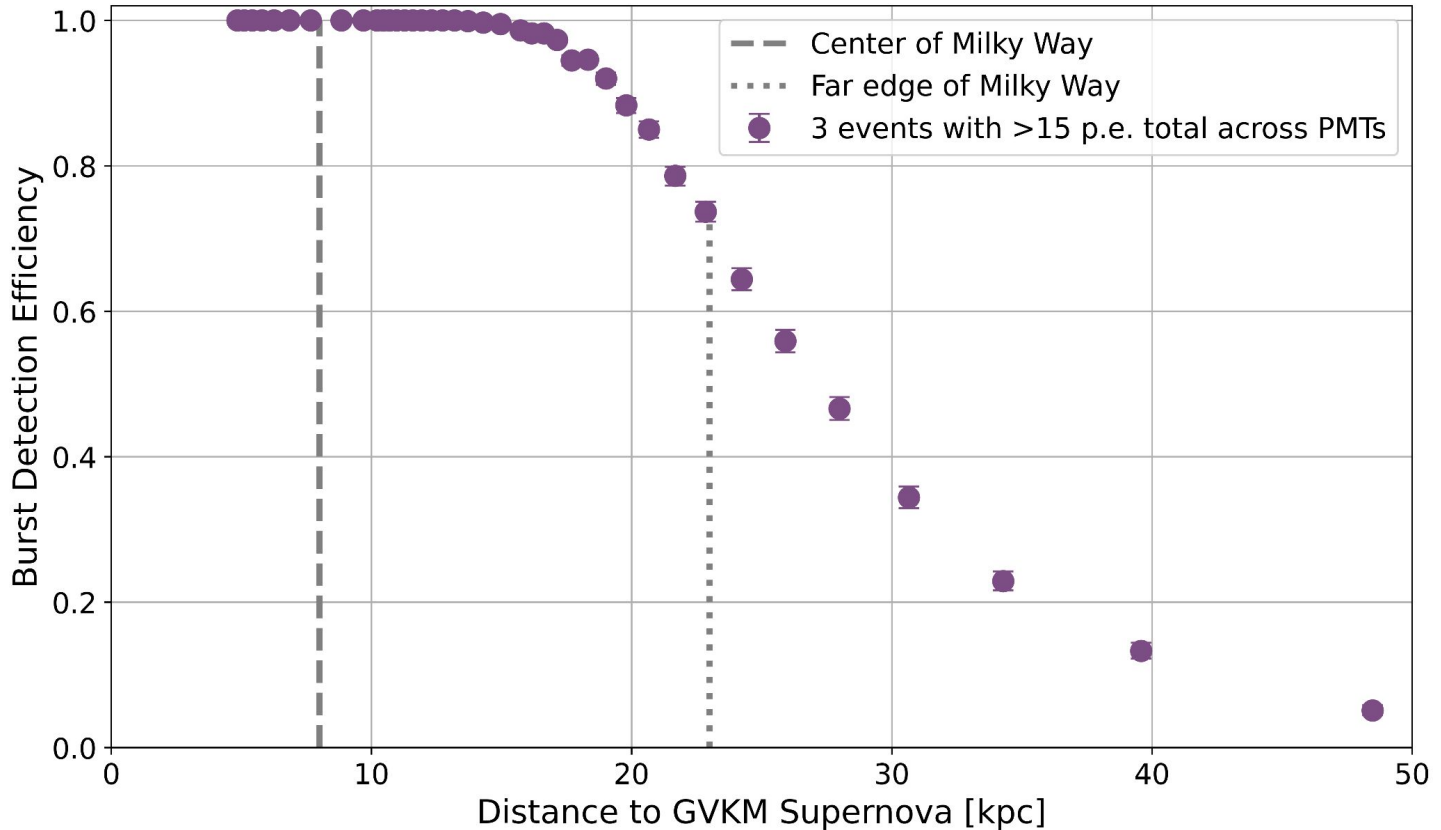

nEXO



Supervisors: Thomas Brunner & Daryl Haggard

+

Thank you for your time!

soudk@stanford.edu

<https://soudkharusi.com>



Special thanks:

T. Brunner & D. Haggard

and ...

... many, many, folks in
the nEXO/SNEWS
collaborations & locally
at McGill!



In Summary

Understanding the origin of neutrino masses is a deep mystery in beyond Standard Model physics

$0\nu\beta\beta$ exploits atomic nuclei to test high-energy theories that allow for neutrino masses

Cosmogenic backgrounds are mitigated in nEXO by using the TPC as a light-only gamma ray spectrometer

A water-Cherenkov muon veto validates the TPC veto and shields against radiogenic backgrounds, it is also sensitive to supernova neutrino bursts across our galaxy