



Canadian Association  
of Physicists

Association canadienne  
des physiciens et physiciennes

2023 CAP Congress /  
Congrès de l'ACP 2023

18 – 23 June 2023 University of New Brunswick

# The Chiral Belle Project: Polarized $e^-$ Beams at SuperKEKB

---

J. Michael Roney

University of Victoria

20 June 2023

*On behalf of the Belle II/SuperKEKB  $e^-$  Polarization Upgrade Working Group*



University  
of Victoria



Canadian Association  
of Physicists

Association canadienne  
des physiciens et physiciennes

2023 CAP Congress /  
Congrès de l'ACP 2023

18 – 23 June 2023 University of New Brunswick

# The Chiral Belle Project: Polarized $e^-$ Beams at SuperKEKB

---

J. Michael Roney  
University of Victoria  
20 June 2023

*On behalf of the Belle II/SuperKEKB  $e^-$  Polarization Upgrade Working Group*

**Snowmass 2021 White Paper**  
**Upgrading SuperKEKB with a Polarized Electron Beam:**  
**Discovery Potential and Proposed Implementation**  
**arXiv:2205.12847**



University  
of Victoria

# Upgrading SuperKEKB with polarized electrons

---

## Opens New Windows for Discovery with Belle II



- Extremely rich and unique high precision electroweak program
- Probe of Dark Sector
- Tau Lepton Magnetic Form factor  $F_2(10\text{GeV}) \rightarrow \tau \ g-2$
- Polarized Beam also provides:
  - Improved precision measurements of  $\tau$  Michel Parameters, electric dipole moment (EDM)
  - Reduces backgrounds in  $\tau \rightarrow \mu\gamma$  and  $\tau \rightarrow e\gamma$  precision leading to significantly improved sensitivities
- hadronic studies

Colliding bunches

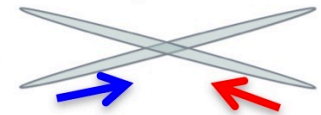

New superconducting / permanent final focusing quads near the IP

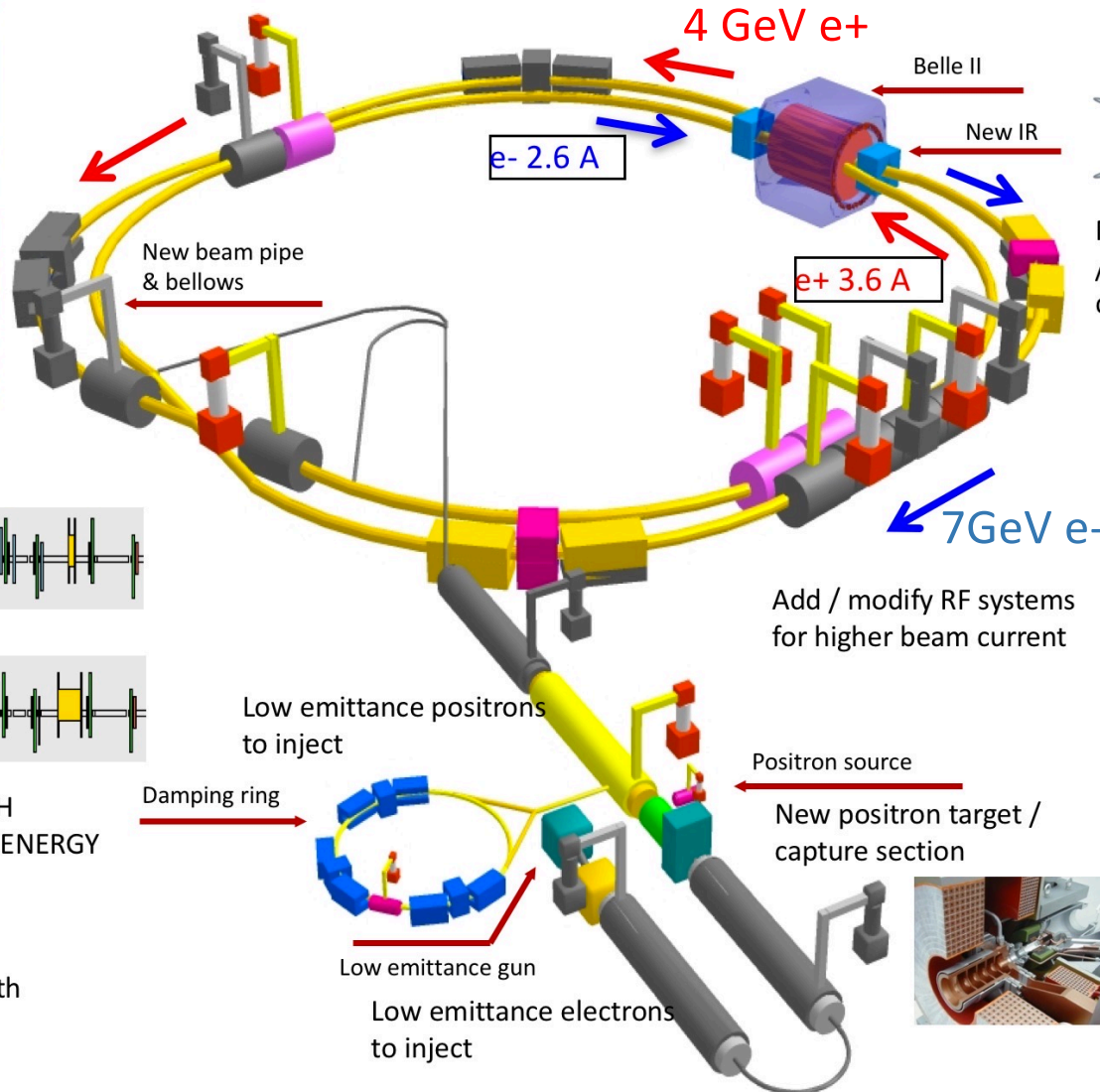

Replace short dipoles with longer ones (LER)

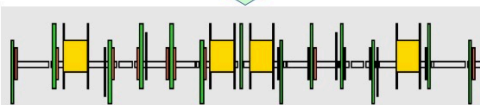
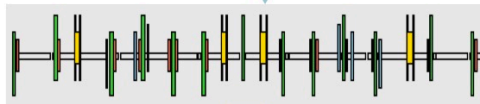

Redesign the lattices of HIGH ENERGY RING (HER) & LOW ENERGY RING (LER) to squeeze the emittance

TiN-coated beam pipe with antechambers

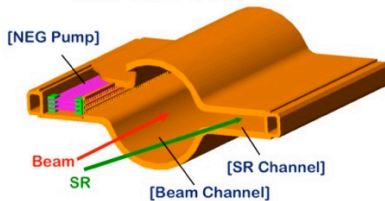

**To obtain x40 higher luminosity**

# A New Path for Discovery in a Precision Neutral Current Electroweak Program

---

- **Left-Right Asymmetries** ( $A_{LR}$ ) yield high precision measurements of the neutral current vector couplings ( $g_V$ ) to each of five fermion flavours,  $f$ :
  - beauty (D-type)
  - charm (U-type)
  - tau
  - muon
  - electron

$$\text{Recall: } g_V^f \text{ gives } \theta_W \text{ in SM} \begin{cases} g_A^f = T_3^f \\ g_V^f = T_3^f - 2Q_f \sin^2 \theta_W \end{cases}$$

as well as light quarks

$T_3 = -0.5$  for charged leptons and D-type quarks  
+0.5 for neutrinos and U-type quarks

# The Standard Model Electroweak fit

## SM fit results: Predictions for EWPO

Also good agreement between indirect determination of EWPO and experimental measurements, with one notable exception

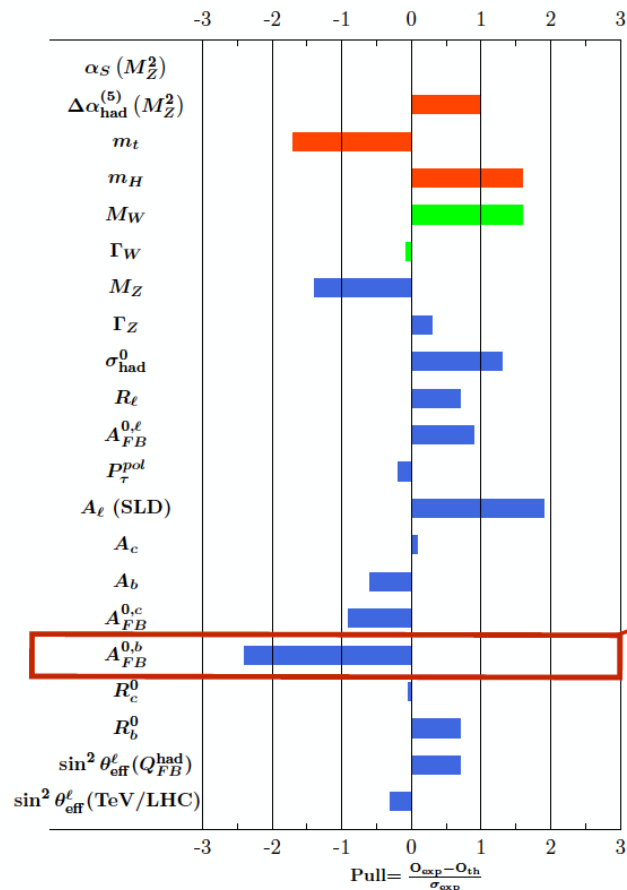

**~2.5  $\sigma$  discrepancy in forward-backward asymmetry of the b quark**  
**Requires modifications of (right-handed)  $Zbb$  couplings**

$$g_{L,R}^b = g_{L,R}^{b\text{SM}} + \delta g_{L,R}^b$$

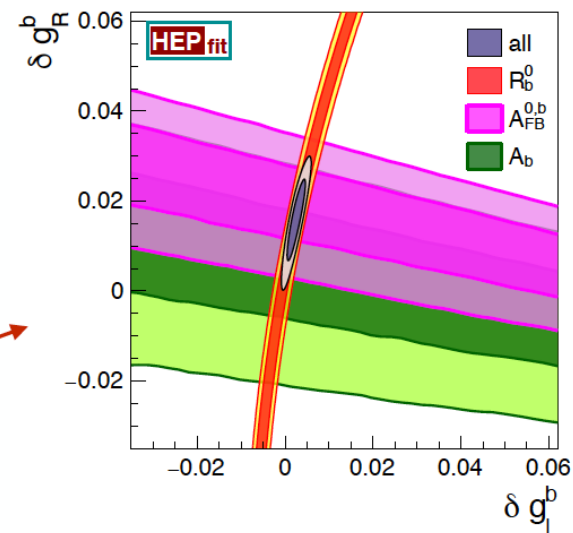

	Fit result	Correlations	
$\delta g_R^b$	$0.017 \pm 0.007$	1.00	
$\delta g_L^b$	$0.003 \pm 0.001$	0.89	1.00

# 'Chiral Belle' -> Left-Right Asymmetries

- Measure difference between cross-sections with left-handed beam electrons and right-handed beam electrons
- Same technique as SLD  $A_{LR}$  measurement at the Z-pole giving single most precise measurement of :

$$\sin^2\theta_{\text{eff}}^{\text{lepton}} = 0.23098 \pm 0.00026$$

- At 10.58 GeV, polarized  $e^-$  beam yields product of the neutral axial-vector coupling of the electron and vector coupling of the final-state fermion via Z- $\gamma$  interference:

$$A_{LR} = \frac{\sigma_L - \sigma_R}{\sigma_L + \sigma_R} = \frac{4}{\sqrt{2}} \left( \frac{G_F s}{4\pi\alpha Q_f} \right) g_A^e g_V^f \langle Pol \rangle$$

$$\propto T_3^f - 2Q_f \sin^2 \theta_W$$

(for s-channel Born)

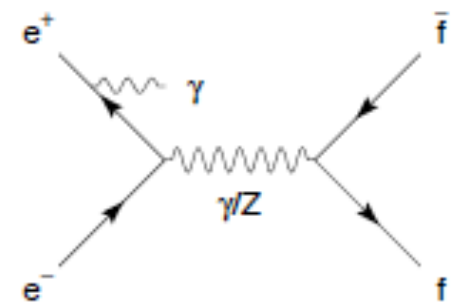

# 'Chiral Belle' Left-Right Asymmetries

Electron helicity would be chosen randomly pulse-to-pulse by controlling the circular polarization of the source laser illuminating a GaAs photocathode.

$$A_{LR} = \frac{\sigma_L - \sigma_R}{\sigma_L + \sigma_R} = \frac{4}{\sqrt{2}} \left( \frac{G_{FS}}{4\pi\alpha Q_f} \right) (g_A^e g_V^f) \langle Pol \rangle$$

$$\propto T_3^f - 2Q_f \sin^2 \theta_W$$

$$\langle Pol \rangle = 0.5 \left\{ \left( \frac{N_R^{e^-} - N_L^{e^-}}{N_R^{e^-} + N_L^{e^-}} \right)_R - \left( \frac{N_R^{e^-} - N_L^{e^-}}{N_R^{e^-} + N_L^{e^-}} \right)_L \right\}$$

Source generates mainly right-handed electrons

Source generates mainly left-handed electrons

(for s-channel Born)

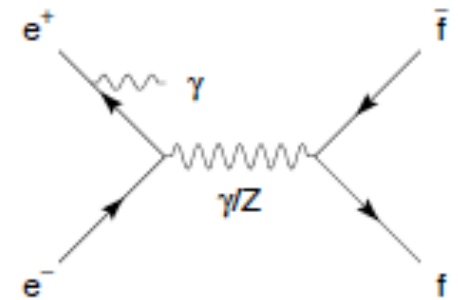

For  $A_{LR}$  calculation with NLO corrections for mu-pair final state, see:  
 Aleksejevs, Barkanova, Roney, Zykunov "NLO radiative corrections for  
 Forward-Backward and Left-Right Asymmetries at a B Factory", [arXiv:1801.08510](https://arxiv.org/abs/1801.08510)



# Existing tension in data on the Z-Pole:

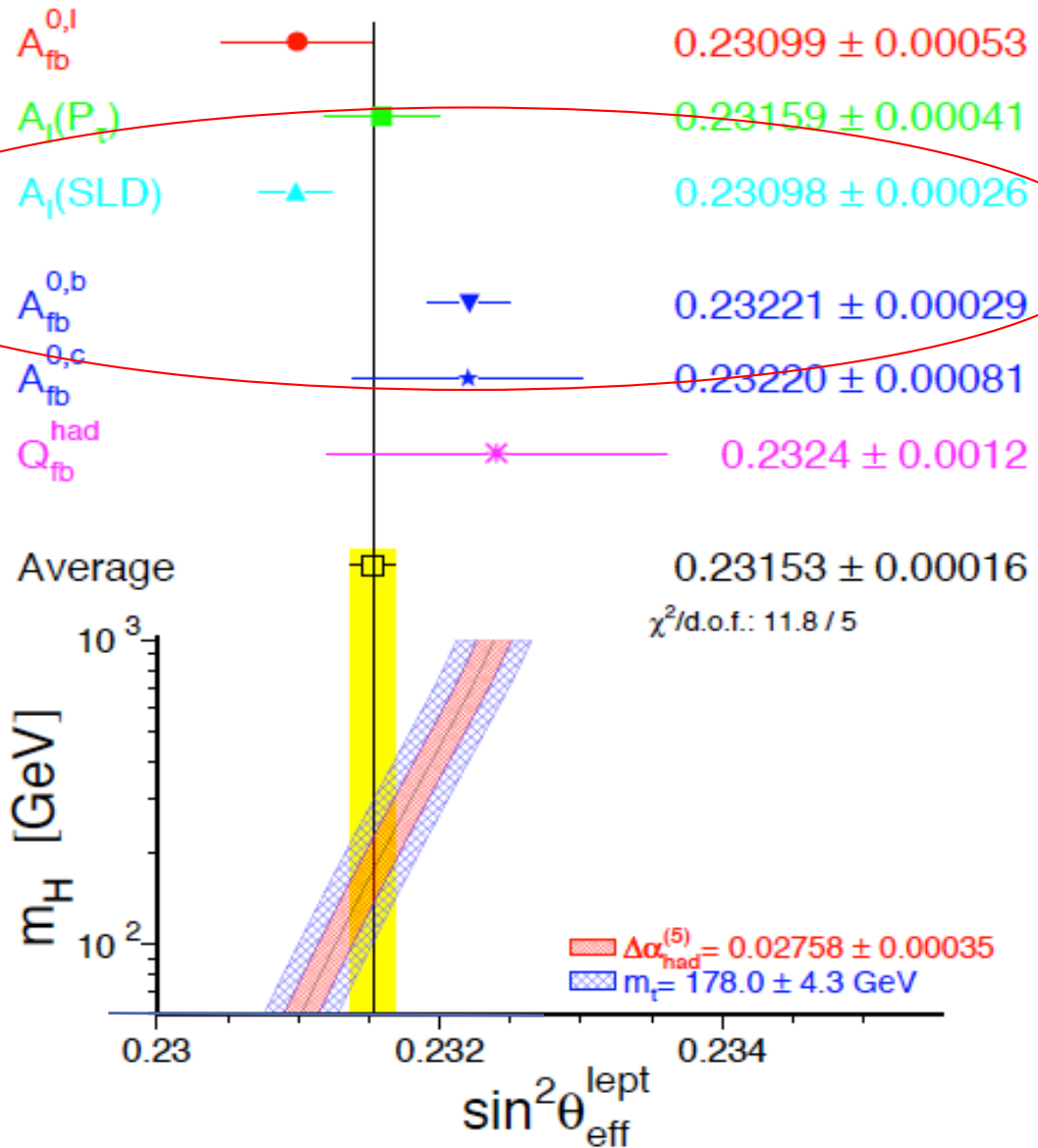

Physics Report Vol 427,  
Nos 5-6 (2006),  
ALEPH, OPAL, L3, DELPHI, SLD

**3.2 $\sigma$  comparing  
only  $A_{LR}$  (SLC) and  
 $A_{fb}^{0,b}$  (LEP)**

# International collaboration of Accelerator and Particle Physicists

## ► Theorists currently working on SM Electroweak calculations:

Aleks Aleksejevs & Svetlana Barkanova, (Memorial U Newfoundland),  
Vladimir Zykunov & Yu.M.Bystritskiy (DUBNA)

$e^+e^- \rightarrow \mu^+\mu^-$

$A_{LR}^{\mu\mu}$  vs  $\sin^2 \theta_W^{eff}$

$e^+e^- \rightarrow e^+e^-$

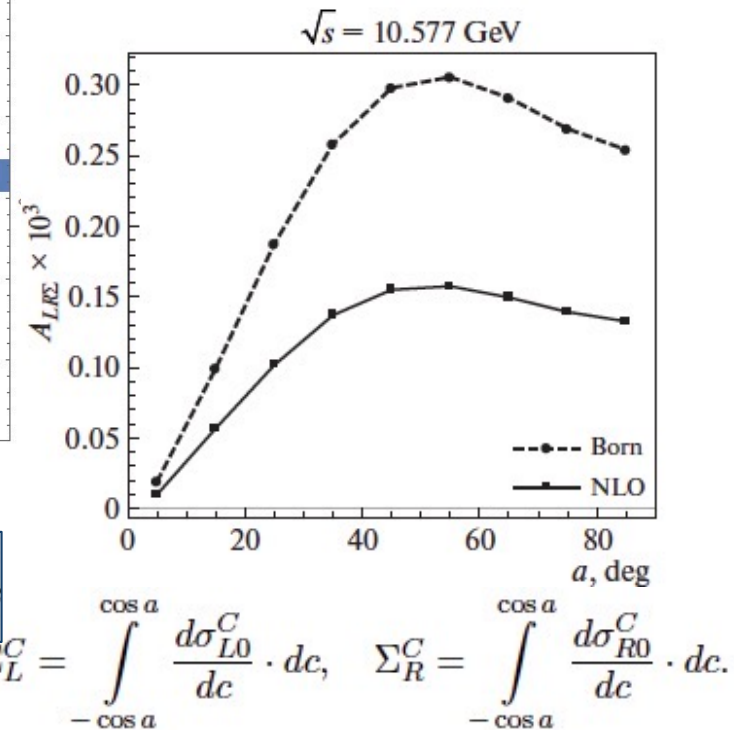
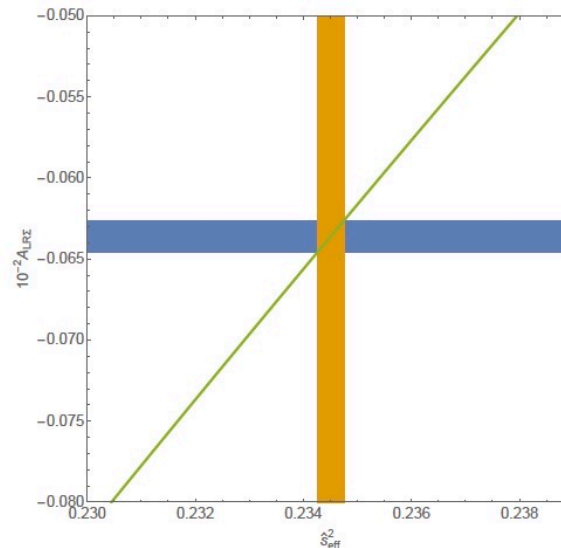
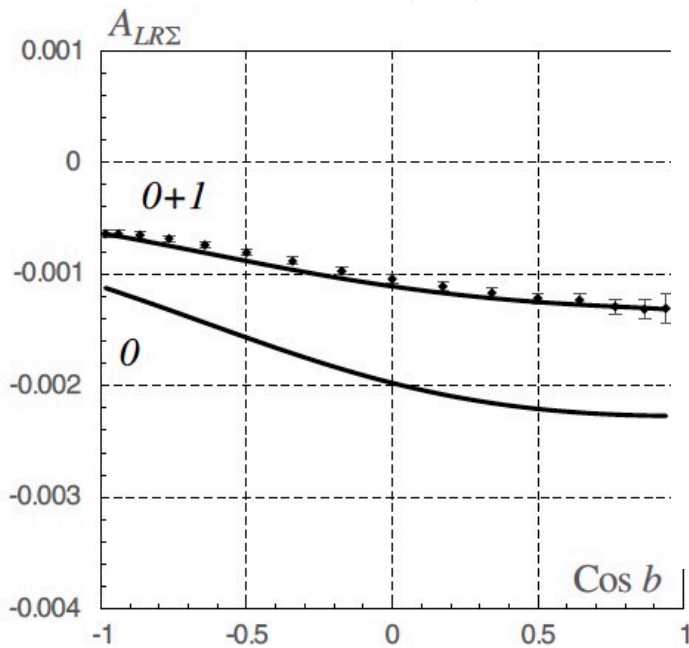

$$\Sigma_L^C = \int_{\cos b}^{\cos a} \sigma_L^C \cdot d(\cos \theta), \quad \Sigma_R^C = \int_{\cos b}^{\cos a} \sigma_R^C \cdot d(\cos \theta)$$

$$A_{LR\Sigma}^C = A_{LR\Sigma}^C(a) = \frac{\Sigma_L^C - \Sigma_R^C}{\Sigma_L^C + \Sigma_R^C}$$

$$\Sigma_L^C = \int_{-\cos a}^{\cos a} \frac{d\sigma_{L0}^C}{dc} \cdot dc, \quad \Sigma_R^C = \int_{-\cos a}^{\cos a} \frac{d\sigma_{R0}^C}{dc} \cdot dc.$$

$a=10^\circ$  & energy of photons  $< 2$  GeV

*Phys.Rev. D101 (2020) no.5, 053003*

*PHYSICS OF ATOMIC NUCLEI Vol. 83 No. 3 2020*

# Recent generator: ReneSANCe

---

Renat Sadykov (JINR,Dubna) and Vitaly Yermolchik (JINR Dubna&INP,Misnk), “Polarized NLO EW  $e^+e^- \rightarrow e^+e^-$  cross section calculations with ReneSANCe-v1.0.0”, *Comput.Phys.Commun.* 256 (2020) 107445; 2001.10755 [hep-ph]

**New generator with beam polarization capable of producing Bhabhas.**

Polarization in each beam and special mode to efficiently calculate  $A_{LR}$  without event generation output.

Caleb Miller (Victoria) has worked with authors on use of ReneSANCe for 10.58GeV SuperKEKB polarization application. Now has single beam polarization.

Comparing ReneSANCe with results published in:

A. G. Aleksejevs (Memorial U, Canada), S.G.Barkanova (Memorial U, Canada), Yu.M.Bystritskiy (JINR, Dubna), and V. A. Zykunov (JINR, Dubna& Gomel), “Electroweak Corrections with Allowance for Hard Bremsstrahlung in Polarized Bhabha Scattering”, *Physics of Atomic Nuclei*, 2020, Vol. 83, No. 3, pp. 463–479

# ReneSANCe *cf* Aleksejevs *et al*

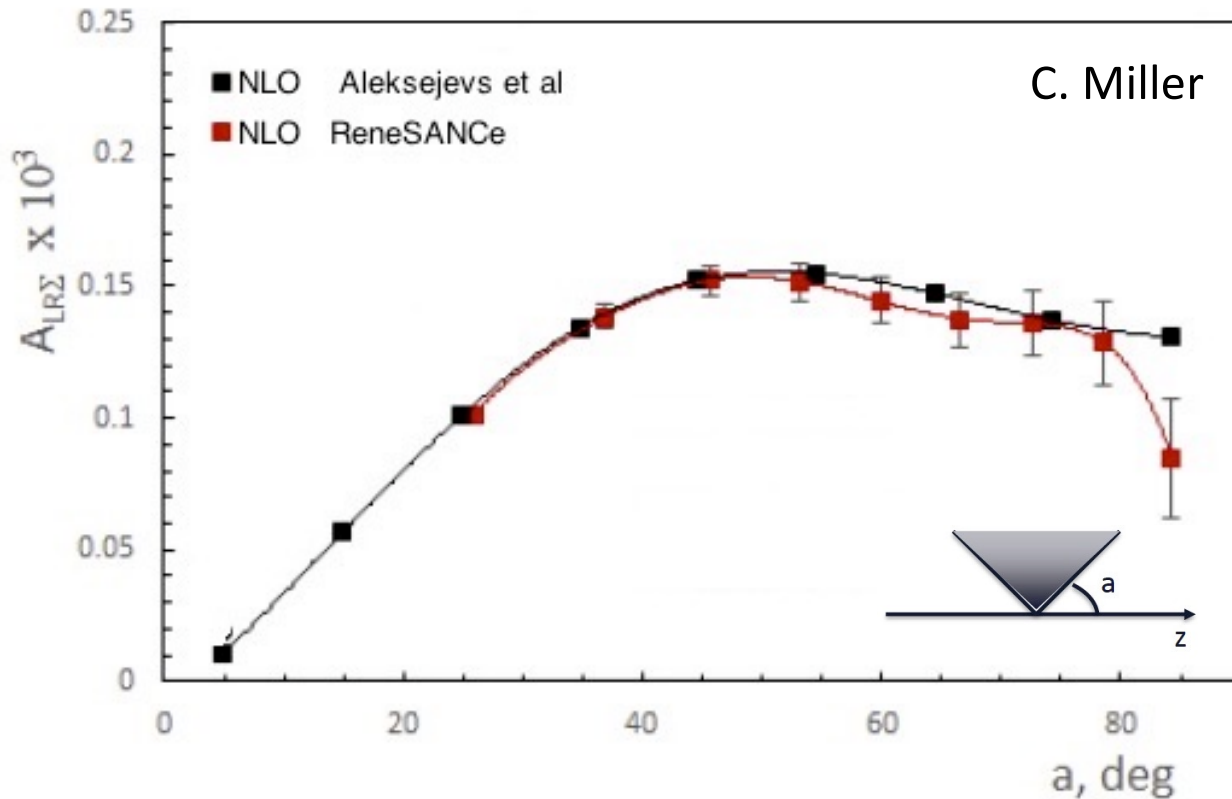

$A_{LR}$  as a function of acceptance angle where  $z$  is  $e^-$  direction in centre-of-mass

Using  $M_W$  variations with ReneSANCe, can find  $\delta \sin^2 \theta_W / \delta A_{LR}$

# ReneSANCe *cf* Aleksejevs *et al*

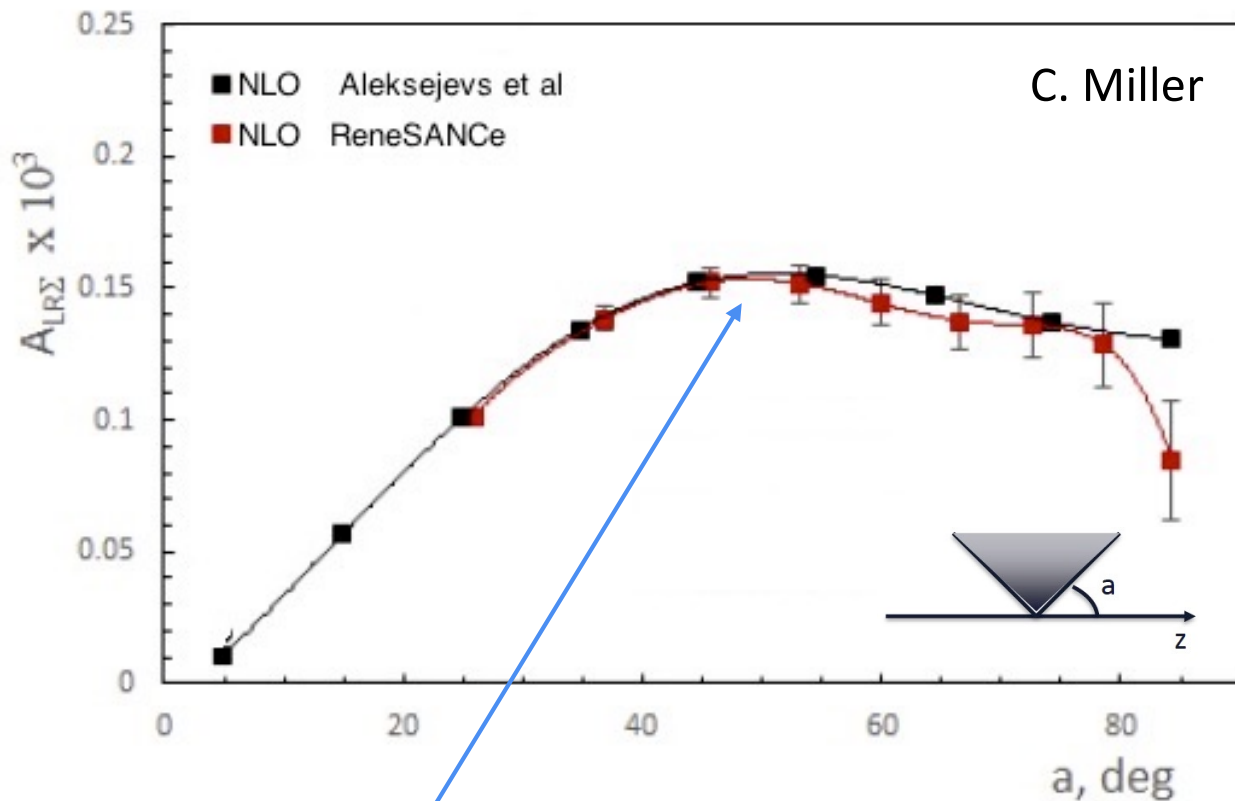

$A_{LR}$  as a function of acceptance angle where  $z$  is  $e^-$  direction in centre-of-mass

Using  $M_W$  variations with ReneSANCe, can find  $\delta \sin^2 \theta_W / \delta A_{LR}$

Belle II has published a luminosity paper with Bhabha acceptance in the central part of the detector:

*F. Abudinén et al, Belle II Collaboration, Chin.Phys.C 44 (2020) 2, 021001*

Reports: Cross-section = 17.4nb, efficiency=36%

# With 70% polarized electron beam get unprecedented precision for neutral current vector couplings

---

Final State Fermion	SM $A_{LR}$ (statistical error & sys from 0.5% $P_e$ ) For 40/ab	Relative Error
b-quark (selection eff.=0.3)	-0.0200 $\pm 0.0001$	0.5%
c-quark (eff. = 0.3)	+0.00546 $\pm 0.00003$	0.5%
tau (eff. = 0.25)	-0.00064 $\pm 0.000015$	2.4%
muon (eff. = 0.5)	-0.00064 $\pm 0.000009$	1.5%
Electron (barrel) (eff. = 0.36)	+0.00015 $\pm 0.000003$	2.0%

1 - Physics Report Vol 427, Nos 5-6 (2006), ALEPH, OPAL, L3, DELPHI, SLD  
 $\sin^2 \Theta_W$  - all LEP+SLD measurements combined  $WA = 0.23153 \pm 0.00016$

# With 70% polarized electron beam get unprecedented precision for neutral current vector couplings

Final State Fermion	SM $g_v^f$ ( $M_Z$ )	World Average <sup>1</sup> $g_v^f$	Chiral Belle $\sigma$ 20 ab <sup>-1</sup>	Chiral Belle $\sigma$ 40 ab <sup>-1</sup>	Chiral Belle $\sigma \sin^2\Theta_W$ 40 ab <sup>-1</sup>
b-quark (eff.=0.3)	-0.3437 ± .0001	-0.3220 ±0.0077 (high by 2.8 $\sigma$ )	0.002 Improve x4	0.002	0.003
c-quark (eff. = 0.3)	+0.1920 ±.0002	+0.1873 ± 0.0070	0.001 Improve x7	0.001	0.0008
Tau (eff. = 0.25)	-0.0371 ±.0003	-0.0366 ± 0.0010	0.001 (similar)	0.0008	0.0004
Muon (eff. = 0.5)	-0.0371 ±.0003	-0.03667±0.0023	0.0007 Improve x 3	0.0005	0.0003
Electron (17nb, eff=0.36)	-0.0371 ±.0003	-0.03816 ±0.00047	0.0009	0.0006	0.0003

1 - Physics Report Vol 427, Nos 5-6 (2006), ALEPH, OPAL, L3, DELPHI, SLD  
 $\sin^2 \Theta_W$  - all LEP+SLD measurements combined WA =  $0.23153 \pm 0.00016$

$\sin^2 \Theta_W$  - Chiral Belle combined leptons with 40 ab<sup>-1</sup> have error ~current WA

# Upgrading SuperKEKB with e- Polarized Beams: Chiral Belle → unique probe of New Physics

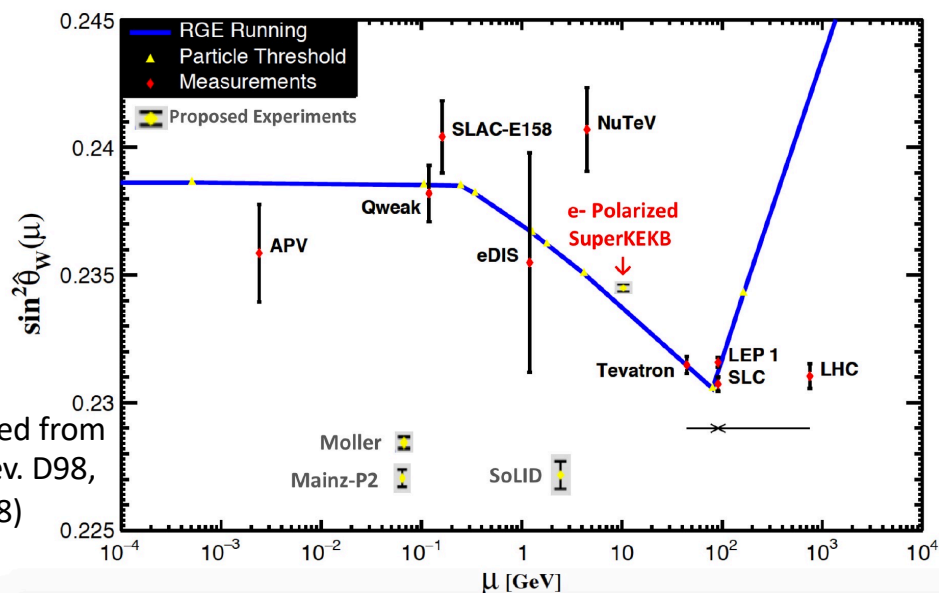

Figure Adapted from PDG Phys. Rev. D98, 030001 (2018)

Chiral Belle:  $\sigma = 0.00018$  ( $40\text{ab}^{-1}$ )  
with only leptonic states  
Precision probe of running of  
the weak mixing angle

Being away from Z-pole opens NP  
sensitivities not available at the  
pole, including  $Z_{\text{dark}}$

Most precise measurements at any energy for

- beauty (4x better than World Average,  $20\text{ab}^{-1}$ )
- charm (7x better than World Average,  $20\text{ab}^{-1}$ )
- muons (4 x better than than WA) (tau and electrons comparable precision as WA)

*Uniquely Probes Neutral Current Universality  
vector coupling of b to that of c:  
 $\sigma(g^b_V/g^c_V) < 0.3\%$ ,  
order of magnitude lower than WA*

Measurements of  $\sin^2\theta_{\text{eff}}^{\text{lepton}}$  of using lepton pairs of comparable precision to that obtained by LEP/SLD, except at  $10.58\text{GeV}$

Probes both lower mass  $Z_{\text{dark}}$  and  $Z' > \text{TeV}$  scale

Unique probe when  $Z_{\text{dark}}$  and  $Z'$  only couples to leptons, including taus



# Upgrading SuperKEKB with e- Polarized Beams: Chiral Belle → unique probe of New Physics

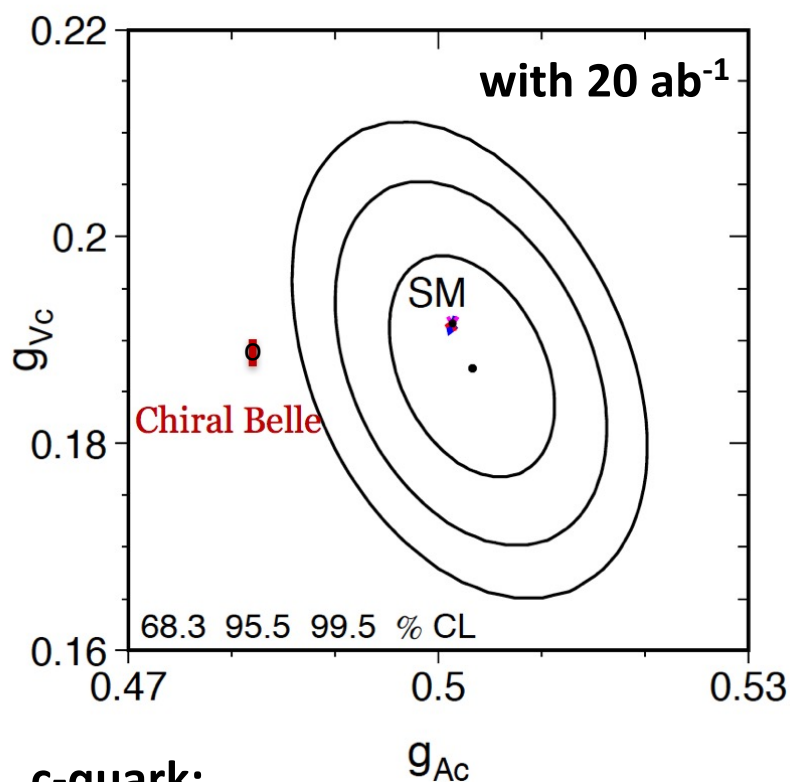

**c-quark:**

Chiral Belle  $\sim 7$  times more precise

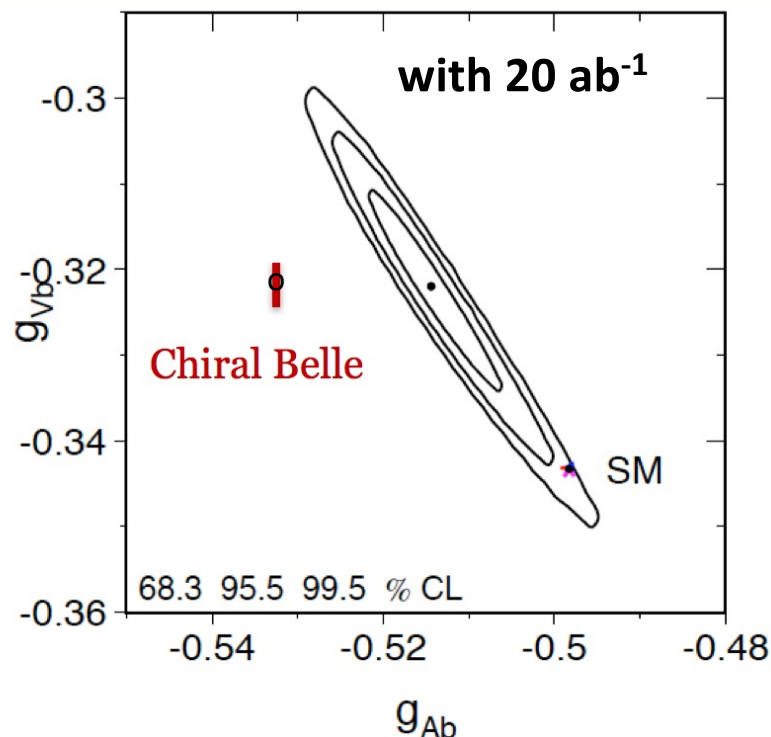

**b-quark:**

Chiral Belle  $\sim 4$  times more precise

*Adapted from  
Physics Report Vol  
427, Nos 5-6 (2006),  
ALEPH, OPAL, L3,  
DELPHI, SLD*

**Probes Neutral Current Universality vector coupling of b to that of c:  
 $\sigma(g_V^b/g_V^c) < 0.3\%$  ( $40 ab^{-1}$ ) → order of magnitude lower than WA**

## Precision electroweak measurements

Fermion	$g_V^f$ (Standard Model)	$g_V^f$ (World Average)	$\sigma(g_V^f)$ (Chiral Belle 40ab <sup>-1</sup> )
b-quark	$-0.3437 \pm 0.0001$	$-0.3220 \pm 0.0077$	0.0020 (4 x improvement)
c-quark	$0.1920 \pm 0.0002$	$0.1873 \pm 0.0070$	0.0010 (7 x improvement)
Tau	$-0.0371 \pm 0.0003$	$-0.0366 \pm 0.0010$	0.0008
Muon	$-0.0371 \pm 0.0003$	$-0.03667 \pm 0.0023$	0.0005 (4 x improvement)
Electron	$-0.0371 \pm 0.0003$	$-0.03816 \pm 0.00047$	0.0006

Combined analysis (assuming universality) :  $\sigma(g_V^f) = 0.00033_{\text{stat}} \pm 0.00018_{\text{sys}}$  [cf. SM error of  $\pm 0.0003$ ]

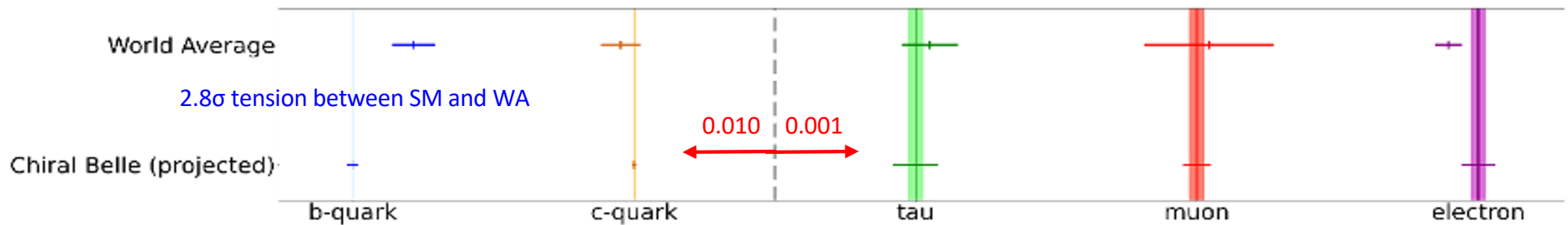

# Chiral Belle probes both high and low energy scales

- Unique sensitivity to Dark Sector parity violating light neutral gauge bosons – especially when  $Z_{\text{dark}}$  is off-shell or couples more to 3<sup>rd</sup> generation
  - Because couplings are small, this sector would have been hidden
  - See e.g. H. Davoudiasl, H. S. Lee and W. J. Marciano, Phys.Rev. D 92, no. 5, 055005 (2015)

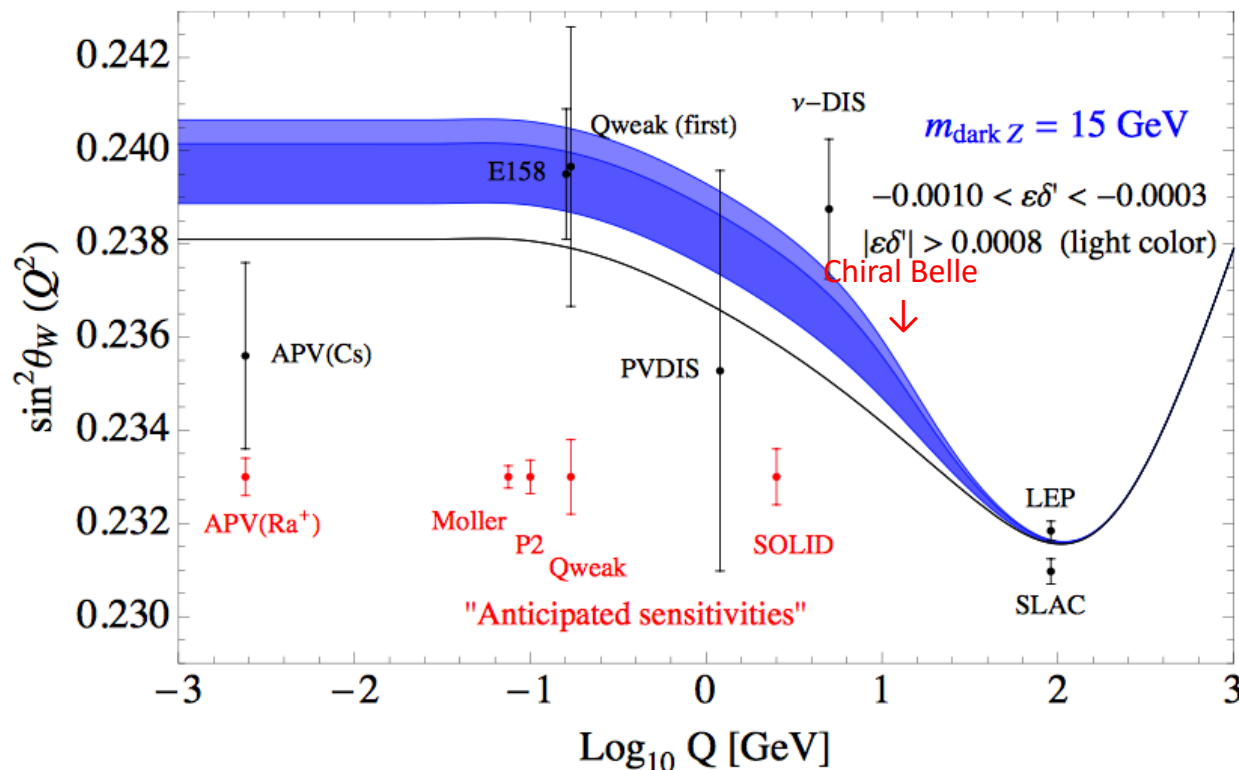

# Upgrading SuperKEKB with e- Polarized Beams: Chiral Belle → unique probe of Dark Sector

## Running of $\sin^2 \theta_W(Q^2)$ : window to the Dark Sector

Dark blue band shows  $Q^2$ -dependent shift in  $\sin^2 \theta_W$  due to 15 GeV parity-violating dark Z

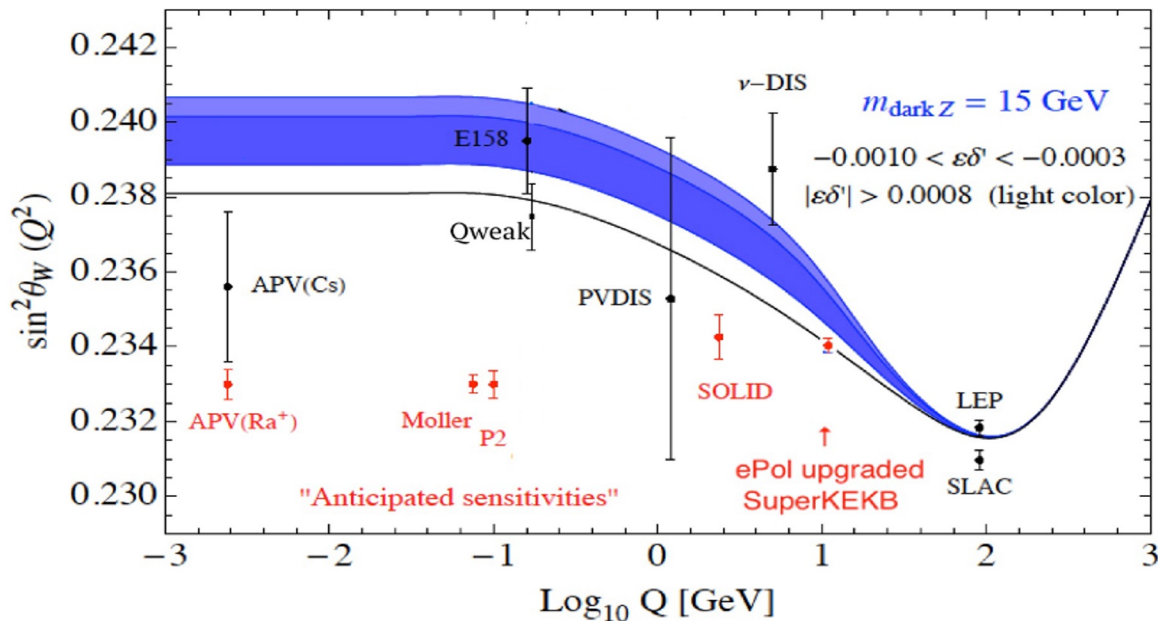

Differences between SM and two benchmark scenarios of dark Z

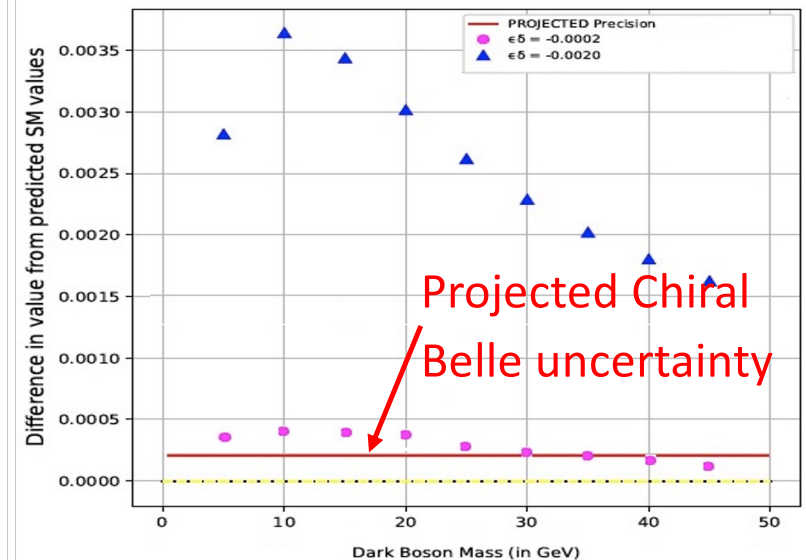

- Adapted from Fig. 3 of H. Davoudiasl, H.S. Lee and W.J. Marciano, Phys.Rev.D 92(5),2015.
- Red bars shows expected  $\pm 1$  sigma uncertainty = 0.0002 with  $40 \text{ ab}^{-1}$  at Chiral Belle [placed at arbitrary positions].
- Also sensitive to parity violation induced by exchange of heavy particles e.g. a hypothetical TeV-scale  $Z'$  boson, which if couples only to lepton will be uniquely produced @ Belle II and not in pp collisions.

# Chiral Belle probes both high and low energy scales

---

Global interest in this EW physics:

- LHC experiments
- APV measurements at lower energy scales
- Moller Experiment at Jefferson Lab which will measure  $\sin^2\theta_{\text{eff}}^{\text{electron}}$  below 100MeV with similar precision (note: Moller is only sensitive to electron couplings.)
- EIC can measure  $\sin^2\theta_{\text{eff}}$  in similar kinematic region, but with less precision and little sensitivity to heavy flavours
- Next generation high energy e+e- colliders: ILC (where polarization is planned) & FCC-ee

# Chiral Belle physics broader program includes:

---

- Tau Lepton Magnetic Form factor  $F_2(10\text{GeV}) \rightarrow \tau$   $g-2$ 
  - **Approaches the precision regime in tau that would be sensitive to Minimal Flavour Violation equivalent of muon  $g-2$  anomaly**
- $\tau$  electric dipole moment (EDM)
- Improved precision measurements of  $\tau$  Michel Parameters
- $e^-$  beam polarization can be used to reduce backgrounds in  $\tau \rightarrow \mu\gamma$  and  $\tau \rightarrow e\gamma$  – leading to improved sensitivities; also electron beam polarization and can be used to distinguish Left and Right handed New Physics currents.
- Polarized  $e^+e^-$  annihilation into a polarized  $\Lambda$  or a hadron pair experimentally probes dynamical mass generation in QCD

# Magnetic dipole moments of $\tau$ lepton

[Andreas Crivellin](#), [Martin Hoferichter](#), [J. Michael Roney](#) arXiv:2111.10378 [hep-ph]

Contributions to  $F_2(s)$  in units of  $10^{-6}$ .

	$s = 0$	$s = (10 \text{ GeV})^2$
1-loop QED	1161.41	-265.90
$e$ loop	10.92	-2.43
$\mu$ loop	1.95	-0.34
2-loop QED (mass independent)	-0.42	-0.24
HVP	3.33	-0.33
EW	0.47	0.47
total	1177.66	-268.77

- Detector level systematics cancels in asymmetries between left (right) beams.
- Precision  $\simeq \mathcal{O}(10^{-5})$  or better expected with  $50 \text{ ab}^{-1}$  of data with polarized beam.
- **1000 x more precise than current limits**
- **Approaches the precision regime in tau that would be sensitive to Minimal Flavour Violation equivalent of muon g-2 anomaly**

# Polarization in SuperKEKB

---

- Goal is ~70% polarization with 80% polarized source (SLC had 75% polarization at the experiment)
- Electron helicity would be chosen randomly pulse-to-pulse by controlling the circular polarization of the source laser illuminating a GaAs photocathode (similar to SLC source)
- **Inject vertically polarized electrons** into the High Energy Ring (HER) - needs low enough emittance source to be able to inject.
- **Rotate spin to longitudinal before Interaction Point**, and then back to vertical after IP using solenoidal and dipole fields
- **Use Compton polarimeter to monitor longitudinal polarization with <1% absolute precision**, higher for relative measurements (arXiv:1009.6178) - needed for real time polarimetry
- **Use tau decays to get absolute average polarization at Interaction Point**



# Polarization in SuperKEKB

---

- These electroweak measurements require highest luminosity possible
- Polarized source not expected to reduce luminosity
- Spin rotators might affect luminosity if not carefully designed to minimize couplings between vertical and horizontal planes
  - Higher order and chromatic effects have to be considered in the design to ensure luminosity is not degraded

# KEK Injection Linac polarization BMAD studies

Y. Peng (UVic)

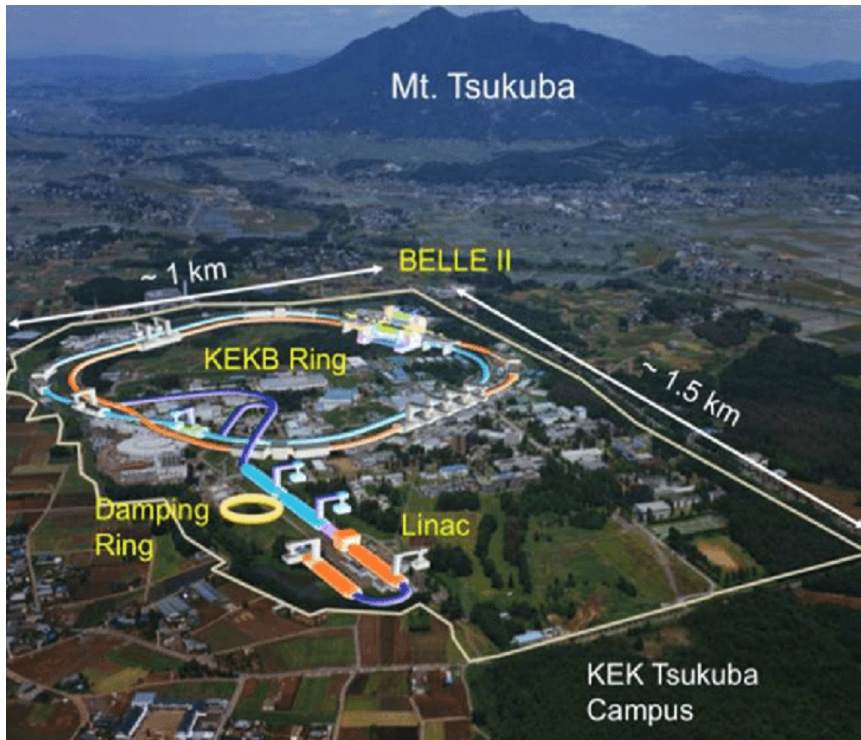

KEK Linac

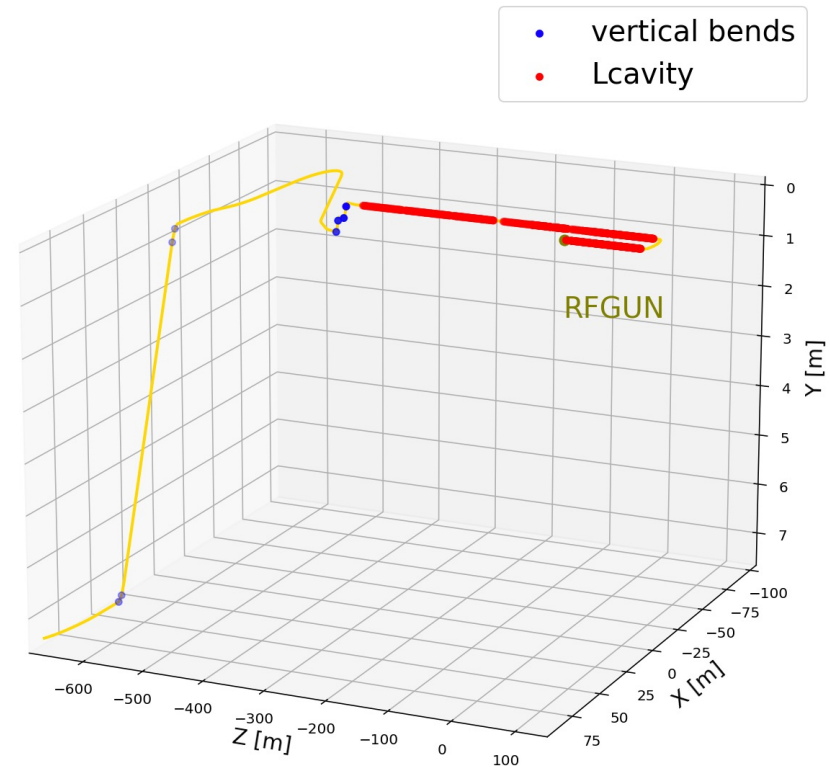

Need transversely polarized beam at the injection point of the e- storage ring (High Energy Ring -HER)

# Spin motion in the KEK Injection Linac

Y. Peng (UVic)

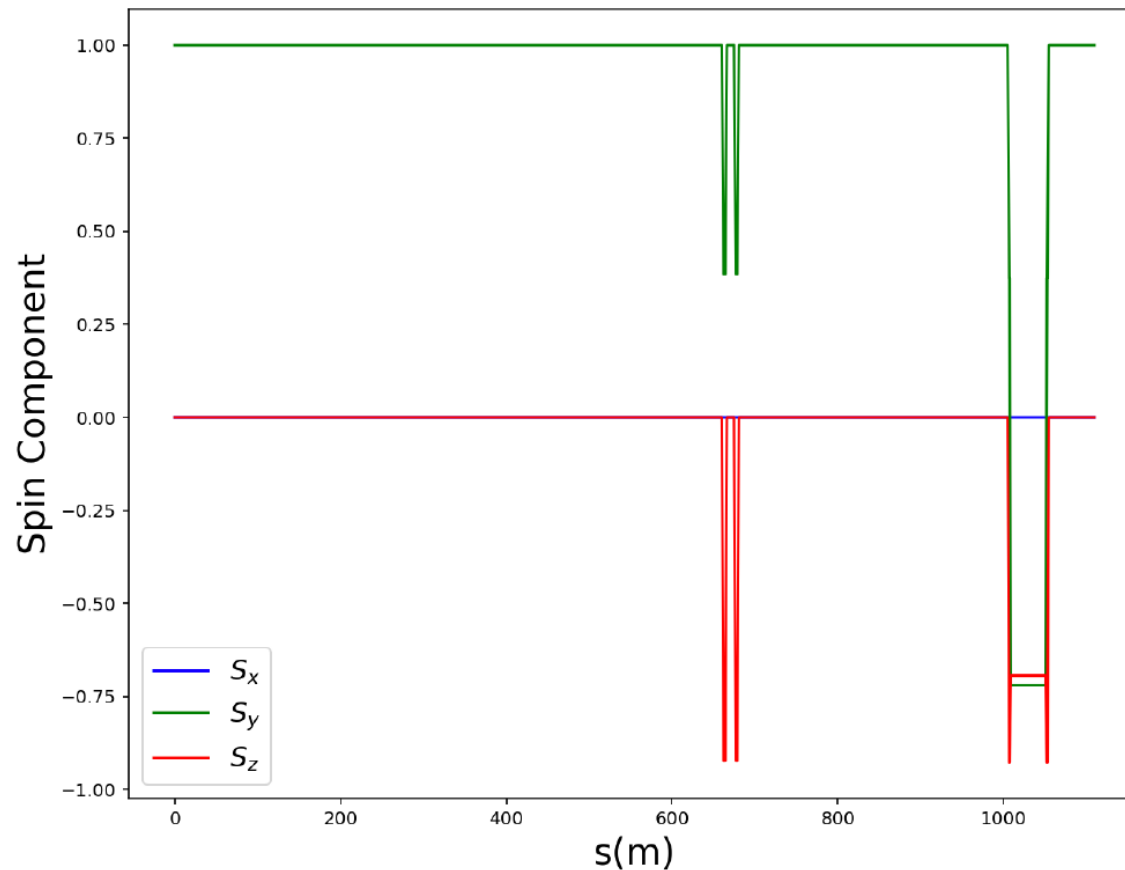

These spin tracking using BMAD show if the electron starts with vertical spin  $(0,1,0)$  at the source, after all the vertical beam motion, it will end up with a vertical spin at the injection point, as desired.

# Transverse polarization survival rate in HER

Y. Peng (UVic)

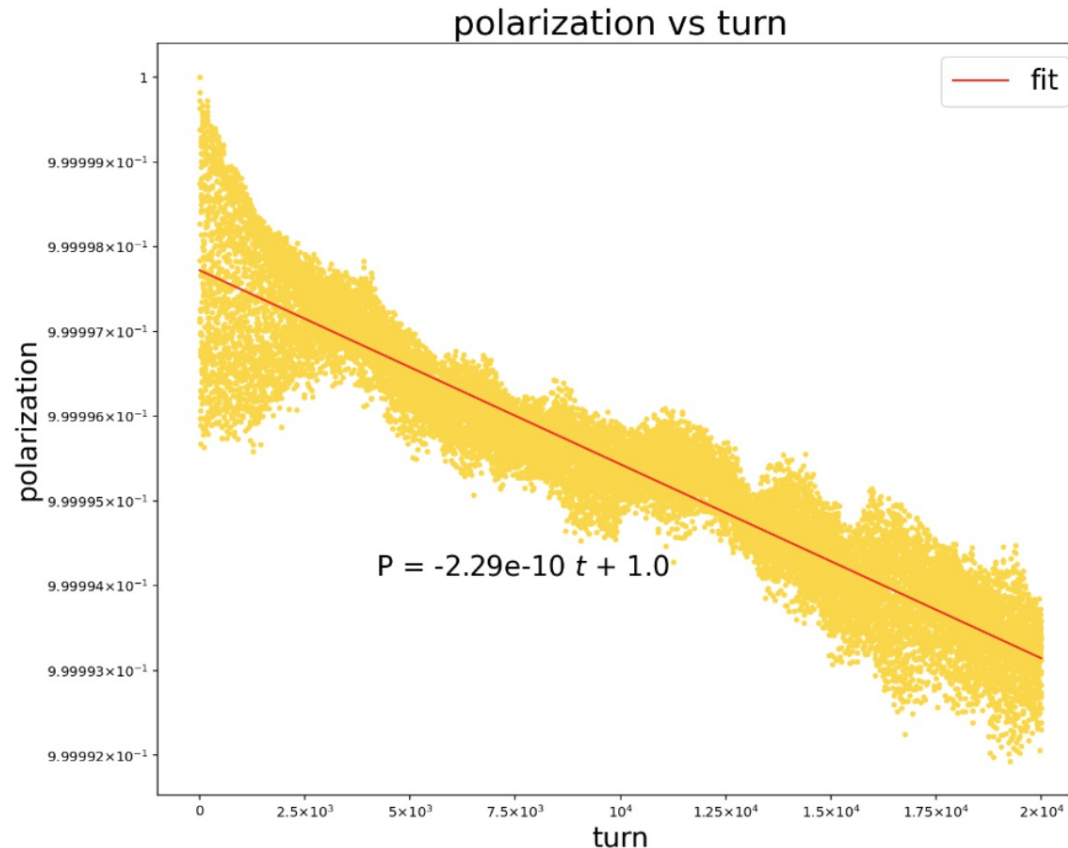

- Tracking 100 particles for 20000 turns in the HER with BMAD
- This study estimates polarization lifetime  $> 10$  hours

# Proposal for Stage 1 of Chiral Belle: Dedicated Study of Transverse Polarization Lifetime

Touschek (i.e. intrabeam scattering) lifetimes increase with transverse polarization. In SuperKEKB e- HER transverse spin lifetime  $\sim 4\%$  effect

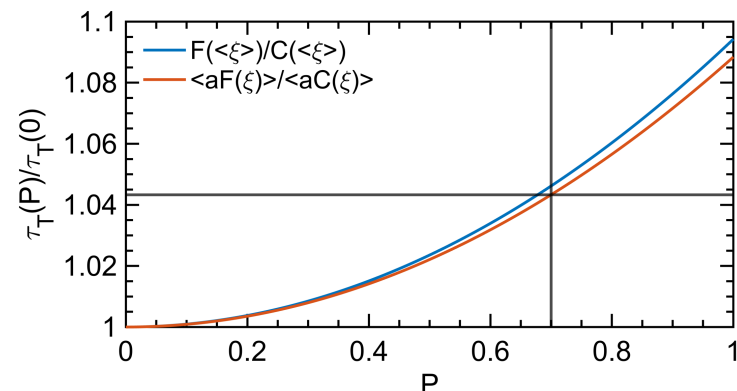

Inject both polarized and unpolarized beams in ring and measure bunch/bunch intensity with time to minimize systematics (feasible according to KEK experts)

Proposing a  $\sim 1$ -2 day dedicated run with transverse polarized beam injection to measure correlation between polarization and Touschek lifetime and measure the spin lifetime

**Goal: validate that transverse spin lifetime is many hours, as BINP and UVic/Argonne studies have independently predicted**

Requires installation of polarized source with Wien Filter to send polarized beam into HER (note: no need for long lifetime source). Proposal will have Touschek lifetime studies with existing data

# Polarization in SuperKEKB

## Hardware needs

1. Low emittance polarized Source
2. Spin rotators
3. Compton polarimeter

Design source photo-cathode

With 4 nC/bunch

20 mm-mrad vertical emittance

50 mm-mrad horizontal emittance

Current focus is on developing GaAs cathode with a thin Negative Electron Affinity (NEA) surface.

**KEK and Hiroshima Groups - work on ILC sources leveraged**

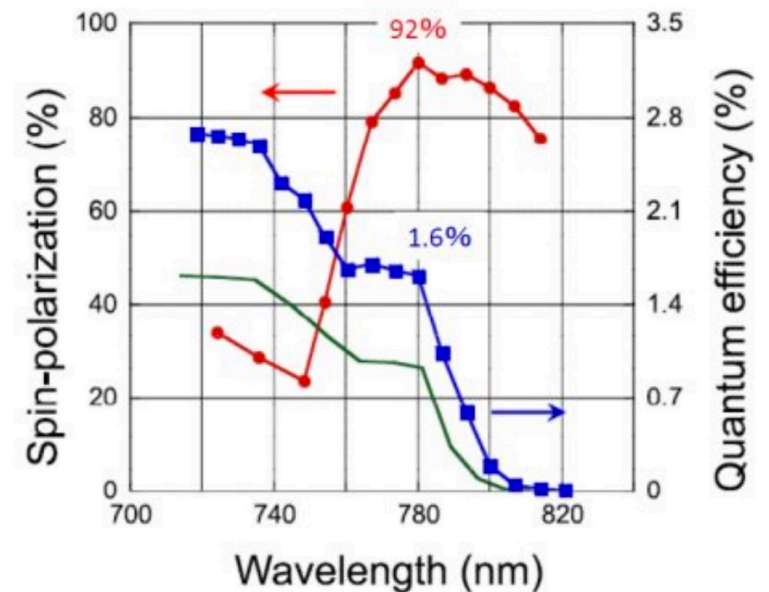

Z. Liptak and M. Kuriki  
(Hiroshima)

# Polarization in SuperKEKB

## Hardware needs

1. Low emittance Source
2. **Spin rotators**
3. Compton polarimeter



Use of solenoids and dipoles, plus the skew-quadrupoles (needed for decoupling) on either side of interaction point

**BINP, ANL, BNL, TRIUMF-Victoria Groups**

# Polarization in SuperKEKB

## Hardware needs

1. Low emittance Source
- 2. Spin rotators**
3. Compton polarimeter

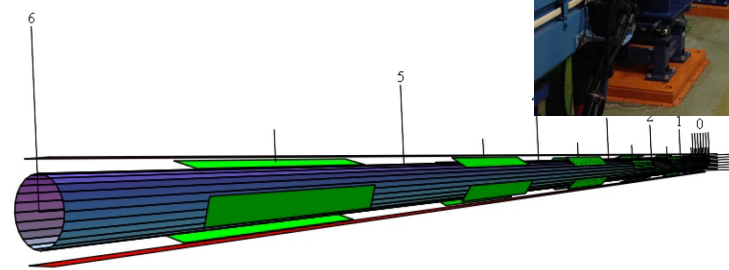

Preliminary studies of two concepts being considered:

- 1) BINP Concepts: Install Spin-rotator magnets in drift regions, requires repositioning of some magnets in ring
- 2) Compact Spin Rotator Concept: Combined-function magnets, which would replace two existing dipole magnets on either side of interaction point.

**BINP, ANL, BNL, TRIUMF-Victoria Groups**



# Novel concept: Compact spin rotator

---

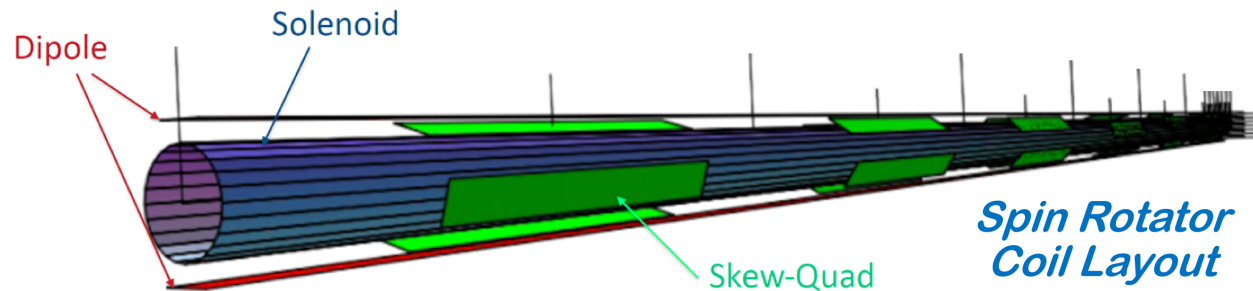

Follows Uli Wienands's (Argonne National Laboratory) idea and direction:

- Replace some existing ring dipoles on both sides of the IP with the dipole-solenoid combined function magnets and keep the original dipole strength to preserve the machine geometry
- Avoids repositioning of other magnets in the ring
- Install 6 skew-quadrupole on top of each rotator section to compensate for the x-y plane coupling caused by solenoids
- **Original machine can be recovered by turning off solenoid and skew-quadrupole fields + retune with only the dipoles**

(BNL expertise in construction of direct wind magnets suitable for these magnets)

# Compact spin rotator

---

## Working Constraints for the Design

- **Transparency:** Need to maintain the original **beam dynamics**, make the spin rotator transparent to the ring as much as possible (the spin rotator is for the polarization purpose only)
- **Physical constraints:** All new magnets must be manufacturable and installable. Brett Parker (BNL) provided these preliminary physical constraints
  - Solenoid strength can not exceed **5 T**
  - Skew-quad can not exceed **30 T/m** ( $\sim 3\text{T}$  at the coil)
- Yuhao Peng (UVic) used BMAD, working with Uli Wienands (ANL) & Demin Zhou(KEK) and consulting with David Sagan (Cornell), found a solution under these constraints
  - Demin Zhou provided SAD lattice files for HER translated for BMAD

# Compact spin rotator

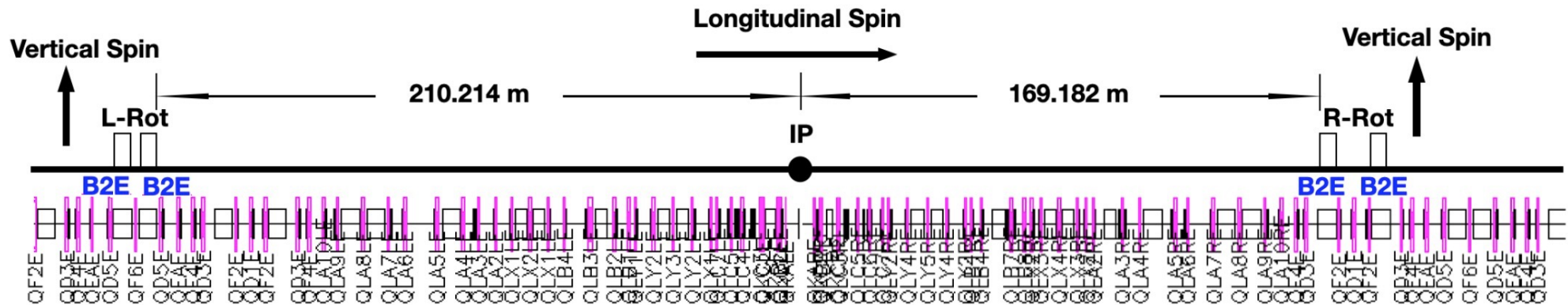

- Left Rotator (L-Rot) rotates the spin from the vertical to the horizontal plane
- Right Rotator (R-Rot) rotates the spin back to the vertical direction
- 4 **B2E** dipoles (using SAD lattice naming convention for HER) shown above to be replaced with the spin rotator magnets

# Compact spin rotator

## Full lattice Comparison with L/R-Rot installed & matched in the HER ring

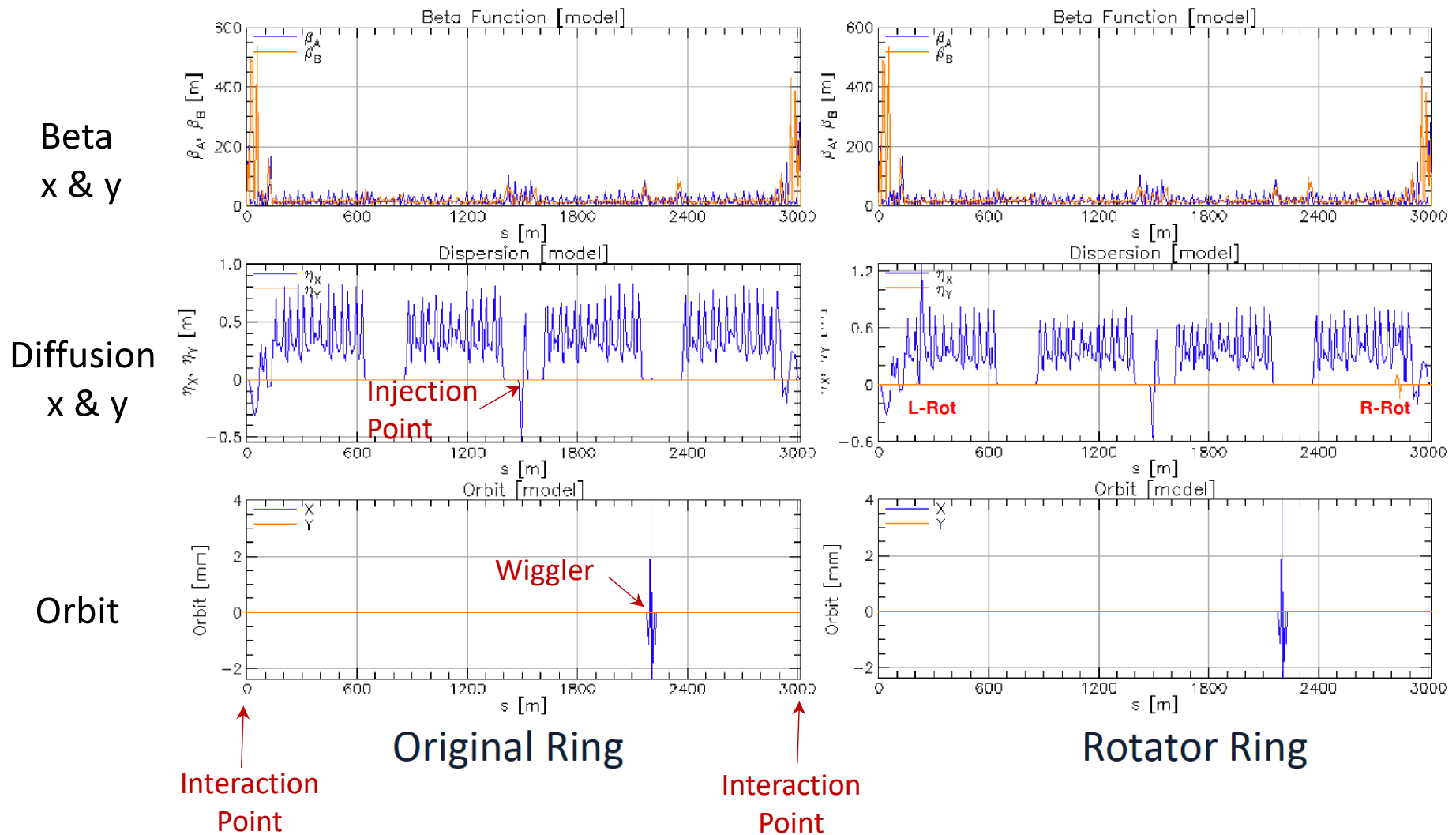

# Compact spin rotator

---

Y. Peng (UVic)

**Ring parameter comparisons with BMAD following closed-geometry optimization and after matching tune and chromaticity to the original HER**

Machine Parameter	Original Ring	Rot Installed
Tune $Q_x$	45.530994	45.530994
Tune $Q_y$	43.580709	43.580709
Chromaticity $\xi_x$	1.593508	1.593508
Chromaticity $\xi_y$	1.622865	1.622865
Damping partition $J_x$	1.000064	0.984216
Damping partition $J_y$	1.000002	1.005266
Emittance $\varepsilon_x$ (m)	$4.44061 \times 10^{-9}$	$4.89628 \times 10^{-9}$
Emittance $\varepsilon_y$ (m)	$5.65367 \times 10^{-13}$	$3.96631 \times 10^{-12}$

# Compact spin rotator

Y. Peng (UVic)

## Single Particle Spin Tracking Result

Spin Component	Entrance of the L-Rot	IP	Exit of the R-Rot
X	-0.0000450734	0.0000066698	0.0000538792
Y	0.9999999959	0.0000926945	0.9999999959
Z	-0.0000788085	0.9999999957	-0.0000728110

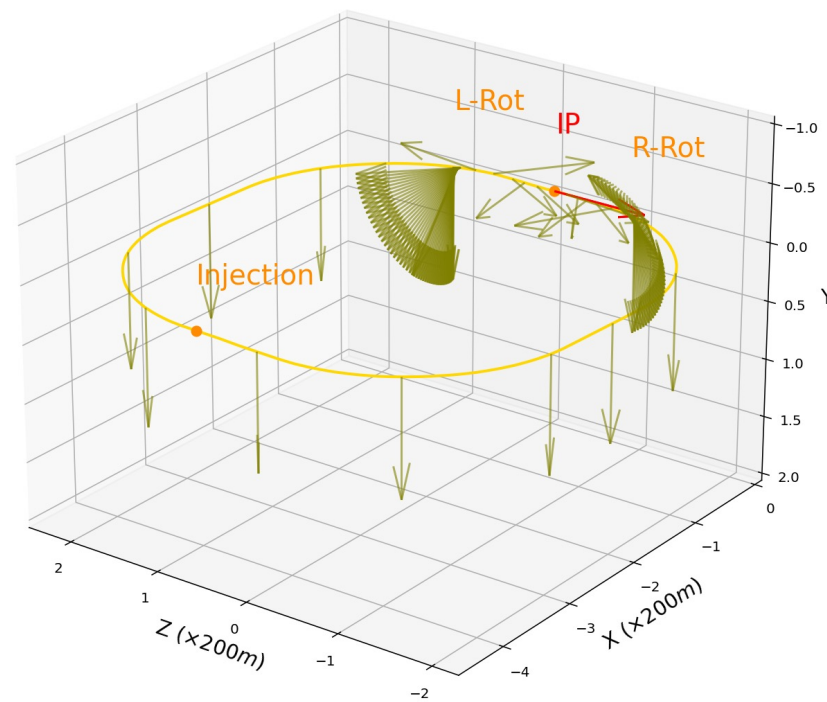

Spin Motion of  $e^-$  (Co-Moving Frame) in the HER with Rot installed

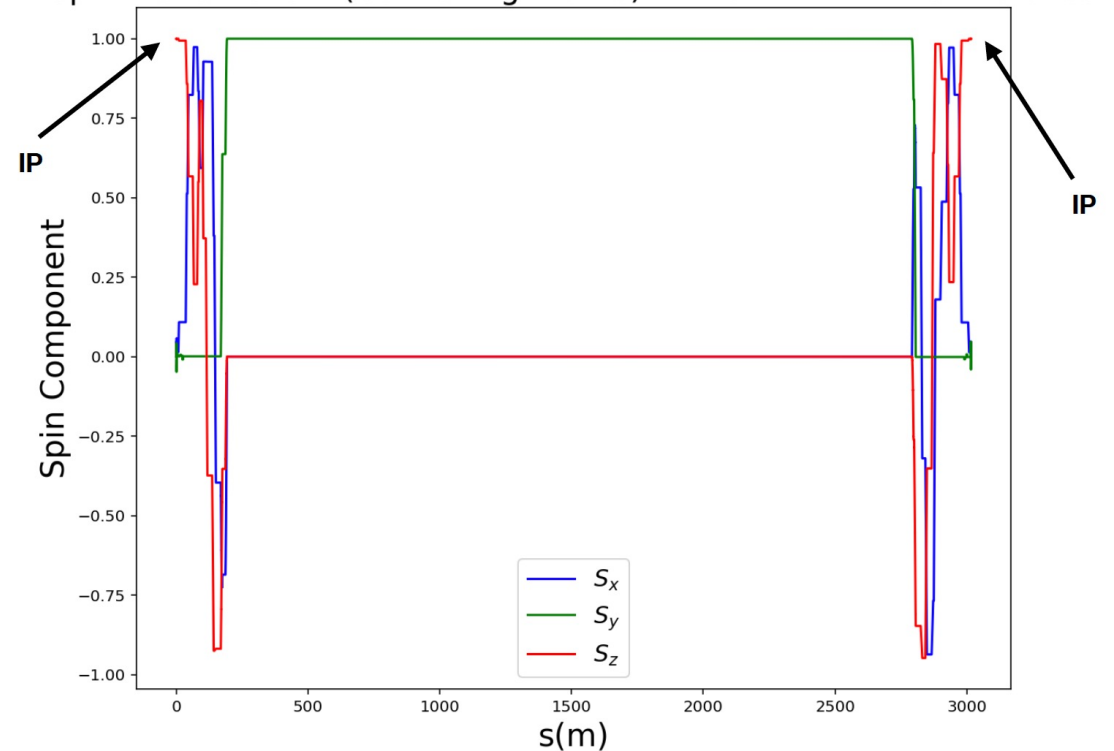

# Compact spin rotator

---

Y. Peng (UVic)

	Solenoid	Field (T)
L-Rot	B2EALSQ	-4.8431
	B2EBLSQ	-2.5774
R-Rot	B2EARSQ	-3.6084
	B2EBRSQ	-3.9420

- Solenoid fields below 5 T limit on existing technology
- Maximum skew-quad strength is  $\sim 20$  T/m, below 30T/m limit on existing technology
- Maximum Ring quad is  $\sim 14$  T/m, which is achievable

# Compact Spin Rotator - Coil Feasibility

Brett Parker (BNL)



*Skew-Quad Coil Pseudo-3D View*

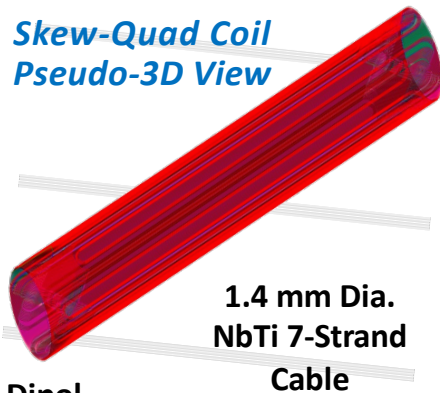

1.4 mm Dia.  
NbTi 7-Strand  
Cable

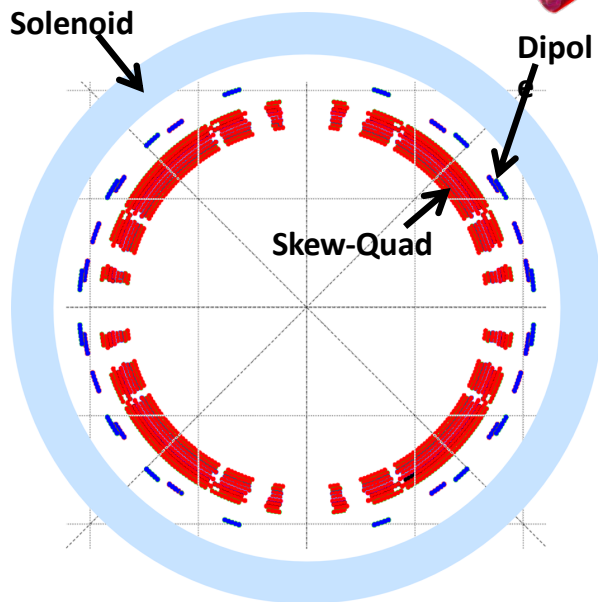

Solenoid Field 4.85 T  
Skew Gradient 24 T/m  
Dipole Field 0.2 T

Combined Field @  
Skew-Quad is 6.15 T  
 $I_{op} = 729$  A  
 $I_q = 1050$  A  
for 69% Short Sample

*Coil Cross Section at Skew-Quad Center*

- We plan to use BNL Direct Wind coil production technique to fabricate the nested coil structure.
- Results from first pass NbTi coil structure shown here yield desired operating margin at 4.22 K.
- Final coil layout requires careful optimization balancing warm-bore, intermediate heat shield, support structure and current lead designs to allow standalone cryocooler operation in tunnel.
- Our R&D results will then be used as a basis for a formal request to appropriate funding agency(ies) for the spin rotator component of a future Belle II based Spin Physics upgrade of SuperKEKB.



# Compact Spin Rotator - Cryostat System Feasibility

Brett Parker (BNL)

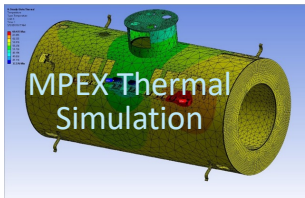
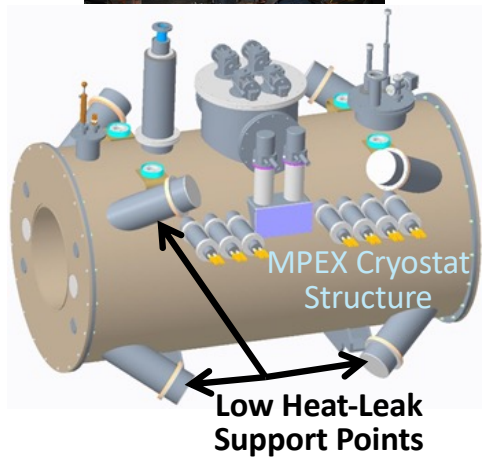

BNL Design Work: Snake magnet in AGS tunnel and conceptual Oak Ridge MPEX cryostat showing warm bore, low heat-leak support structure, current leads and integrated cooling via cryocoolers.

- Basic consideration: enough warm bore to accommodate HER beam pipe with water cooling and vacuum features.
- Also need some radial space for inner cryostat heat shield.
- But skew-quad inner radius should be as small as possible in order to limit peak field (we want to use NbTi cable!).
- We are far from any cryogenic supply; so, use cryocoolers.
- Cryocooler capacity depends upon heat leak: e.g., the heat shield, support structure and current lead requirements.
- For redundancy/rapid maintenance use closed “wet system.”
- We need a self-consistent pre-conceptual design to find out basic info’ such as helium structure (cryogenic safety input).
- Feedback from mechanical design used to adjust coil design and ultimately validate magnetic strengths for HER optics.

41

# Compact spin rotator

## Initial preliminary Frequency Map Analysis (FMA)

dynamic aperture studies using BMAD – show no large changes

work by Noah Tessema (UVic)

Original HER Lattice

her.bmad

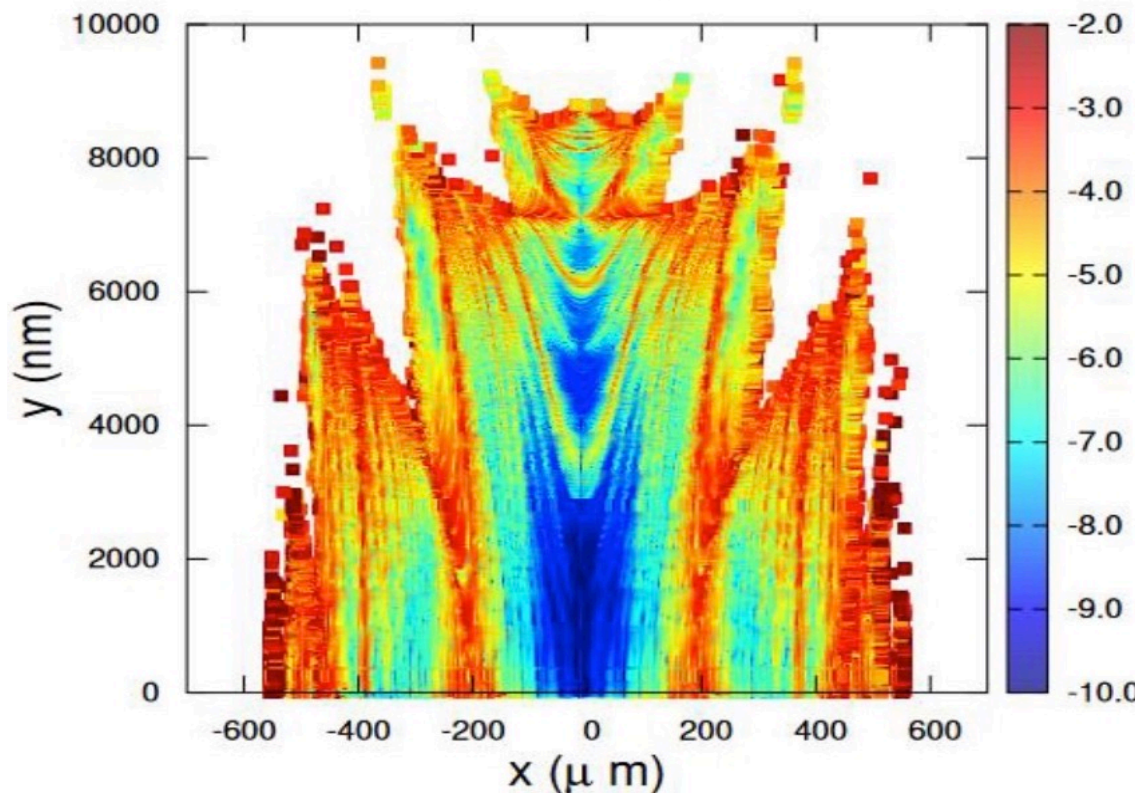

HER Lattice with spin rotator

Rot.bmad

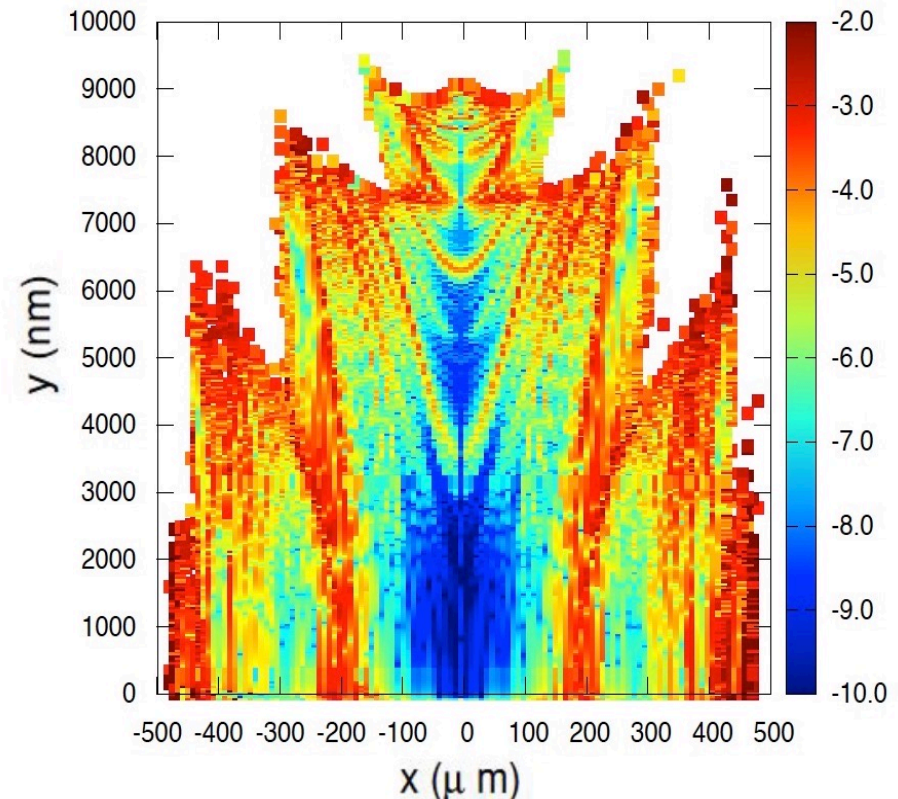

# Compact spin rotator

## Initial preliminary Frequency Map Analysis (FMA) dynamic aperture studies using BMAD – show no large changes

work by Noah Tessema (UVic)

Original HER Lattice

her.bmad

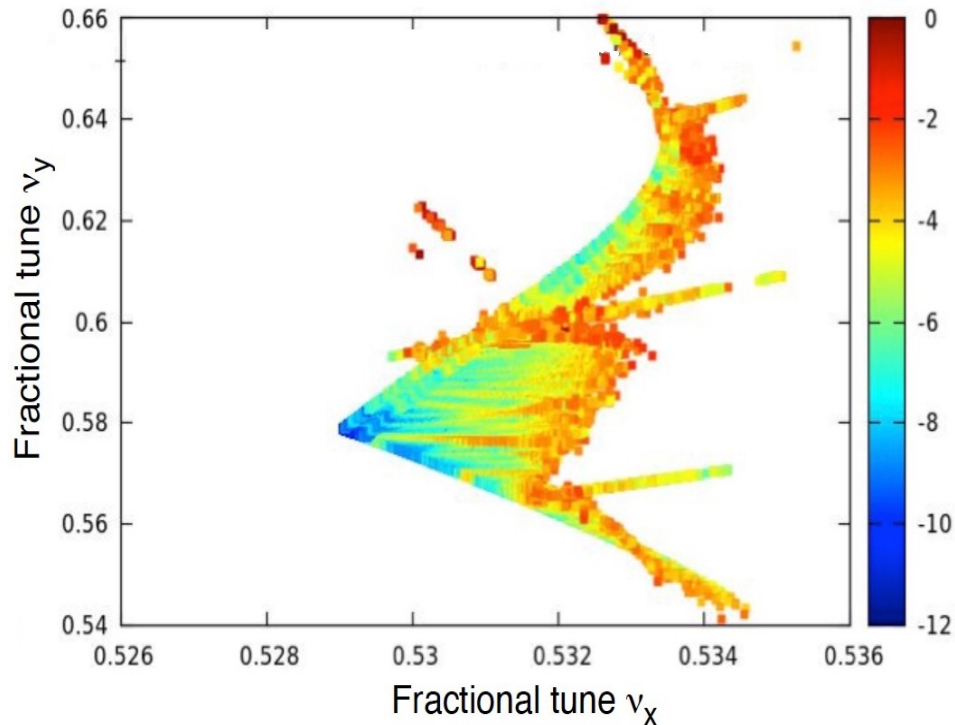

HER Lattice with spin rotator

Rot.bmad

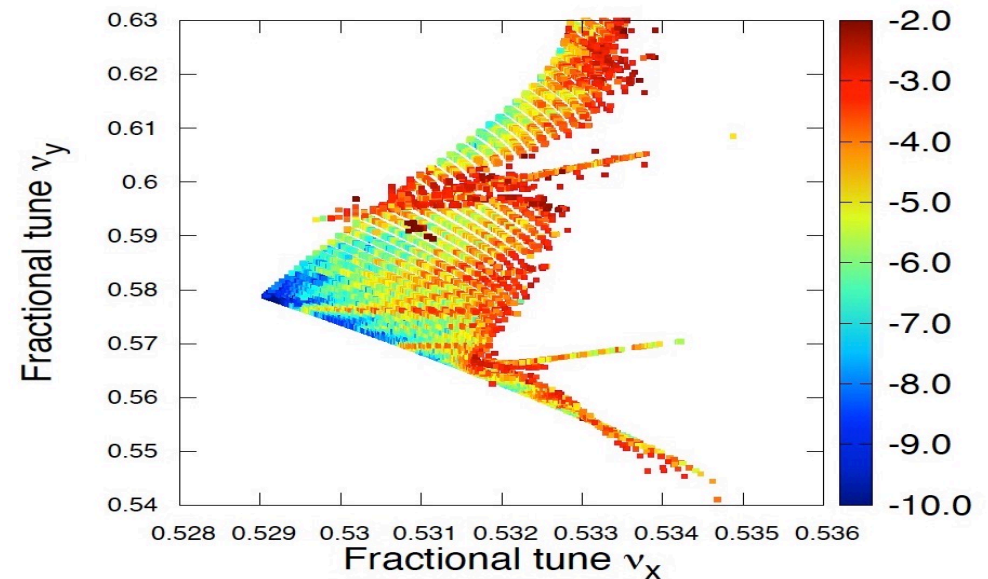

**Next steps: Long Term Tracking studies with radiation damping and radiation fluctuations/quantum excitation**

# Polarization in SuperKEKB

---

## Hardware needs

1. Low emittance Source
2. Spin rotators
- 3. Compton polarimeter**

Space is available outside  
Cryostats for the final focusing quads

**LAL Orsay and U. Manitoba groups**



Figure 1: SuperKEKB left side cryostat at KEK.

# Polarization in SuperKEKB: Compton polarimeter

IJCLab IN2P3 team (A. Martens, Y. Peinaud, F. Zomer, P. Bambade, F. Le Diberder, K. Trabselsi) HERA Compton Polarimeter experience

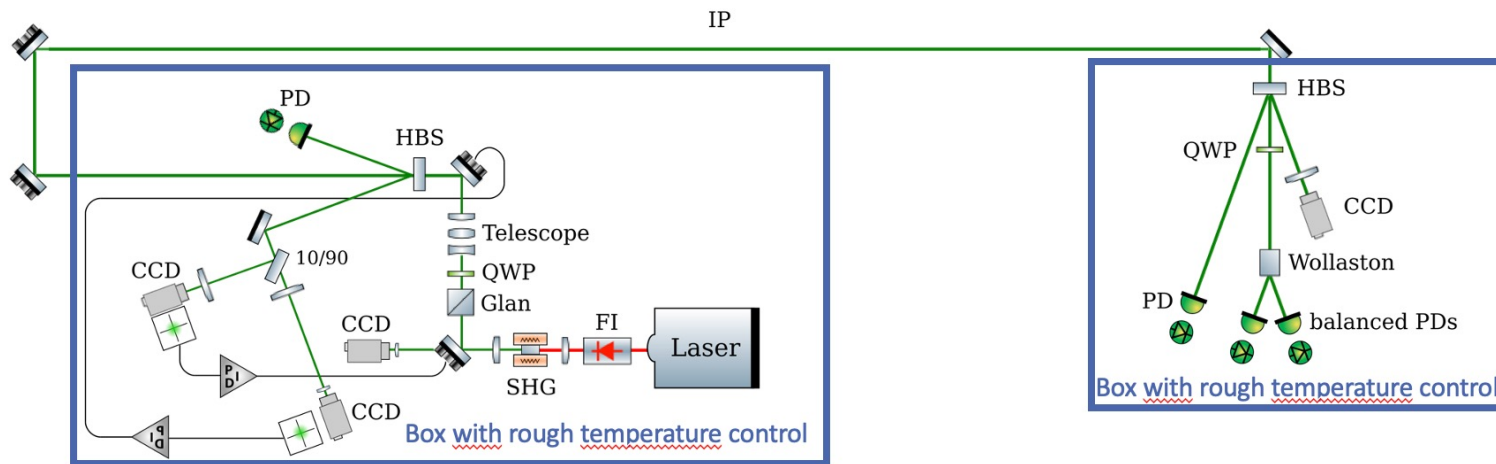

Main challenges related to laser integration in a pre-defined environment

High rep-rate (250MHz) laser considered --> detection capabilities

Polarization control and accurate monitoring is being worked on at IJCLab

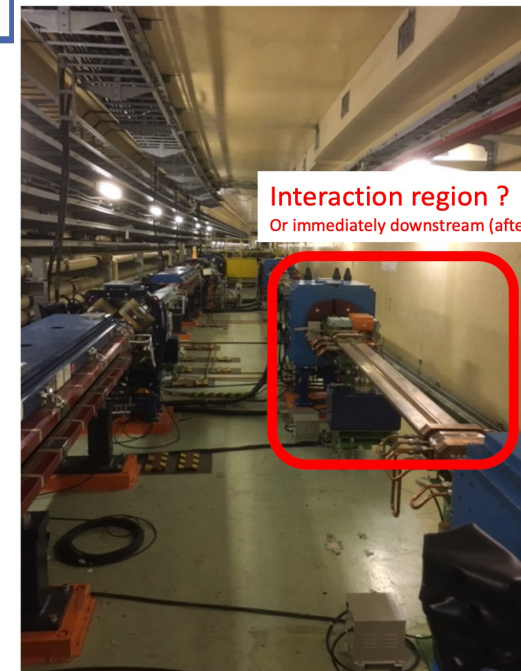

# Compton Polarimeter Studies of Location – A. Martens(IJCLab)

‘minor’ modifications of BLA2LE region

- actually no modification of magnet needed (contrary to initial suspicion)
- NEG pumping not on the ‘right’ side either

Requires modification of a pipe to let photon beam out

- proposed pipe modification (validated by T. Ishibashi and D. Zhou)

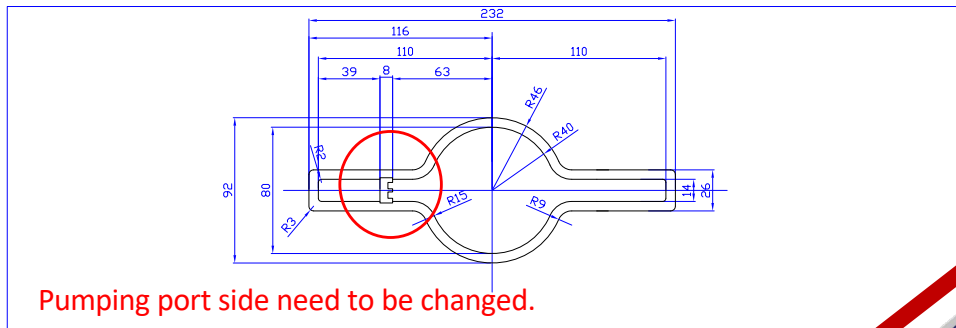

Pumping port side need to be changed.

## Photon detector integration

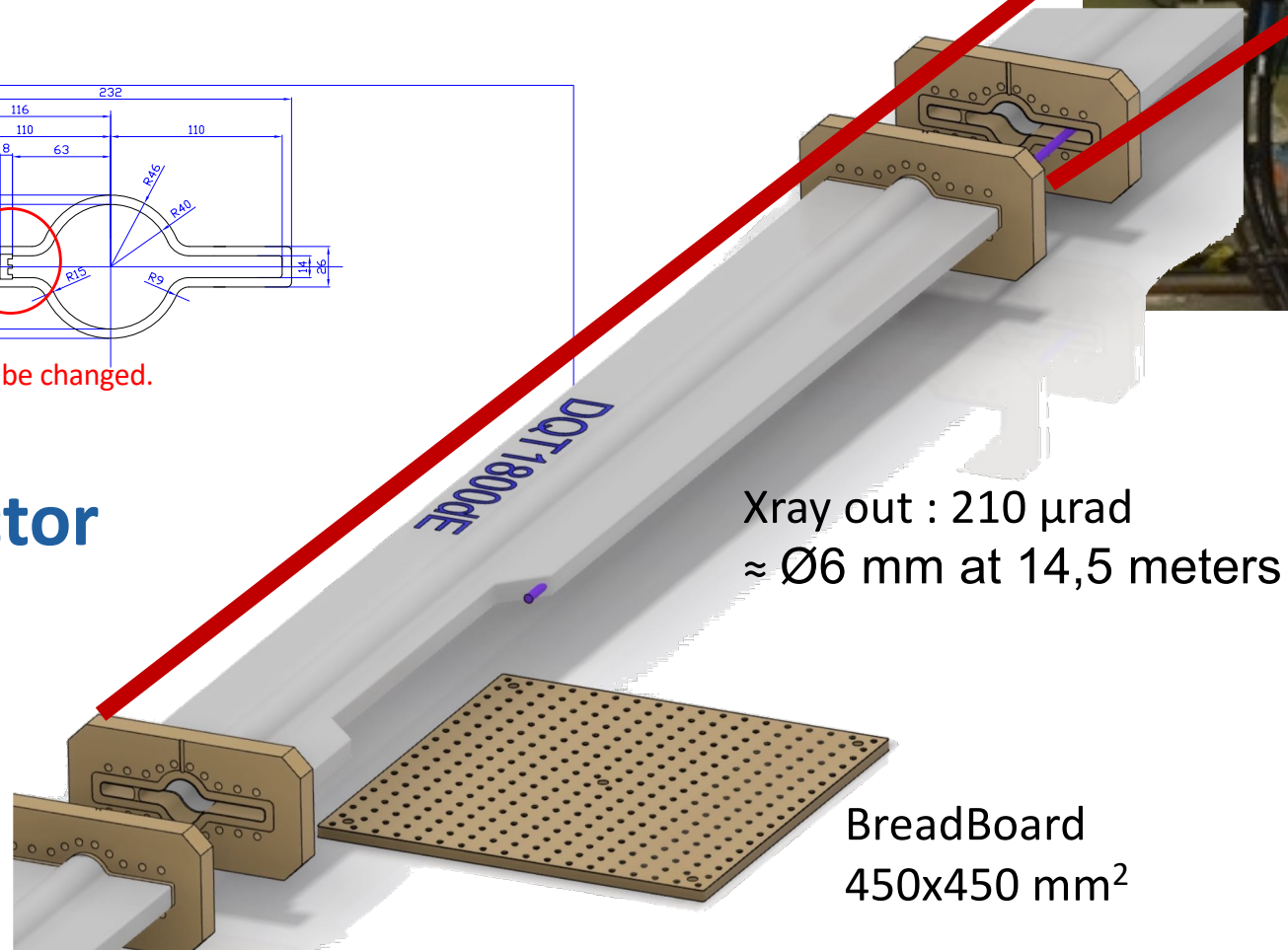

Xray out : 210  $\mu$ rad  
 $\approx \text{Ø}6$  mm at 14,5 meters

BreadBoard  
450x450 mm<sup>2</sup>

# Polarization in SuperKEKB: Compton polarimeter

**U. Manitoba team** (J. Mammei, M. Gericke, W. Deconinck)

**work on Compton polarimeter at JLab - QWeak and MOLLER –**

**Using HPVMAPs as Compton e- Detector at MOLLER**

HVMAPS Beam Test, Fall 2019, DESY

We recently had a beam test of the 8<sup>th</sup> (2x1 cm<sup>2</sup>) and 9<sup>th</sup> generation chip at DESY.

Version 10 will be submitted for production by the end of this year (full 2x2 cm<sup>2</sup>).

If it performs well, version 11 (2020 submission) will be the production chip we use for MOLLER.



Version 8 at UofM

The chip is primarily developed by groups at the U. of Heidelberg and the Karlsruhe Institute of Technology, and intended for various experiments:

- ATLAS
- Mu3e
- PANDA
- P2
- MOLLER



The implementation as a Compton detector is done by the Manitoba group.

## Calculations/Simulations

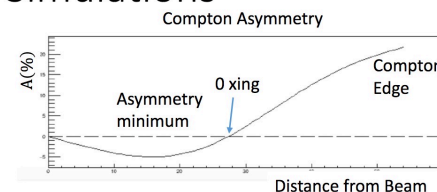
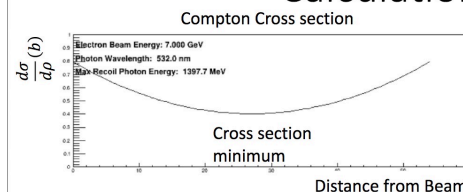

# Tau Polarization as Beam Polarimeter

---

$$P_{z'}^{(\tau^-)}(\theta, P_e) = -\frac{8G_{FS}}{4\sqrt{2}\pi\alpha} \operatorname{Re} \left\{ \frac{g_V^l - Q_b g_V^b Y_{1S,2S,3S}(s)}{1 + Q_b^2 Y_{1S,2S,3S}(s)} \right\} \left( g_A^\tau \frac{|\vec{p}|}{p^0} + 2g_A^e \frac{\cos\theta}{1 + \cos^2\theta} \right) + P_e \frac{\cos\theta}{1 + \cos^2\theta}$$

- Dominant term is the polarization forward-backward asymmetry ( $A_{FB}^{\text{pol}}$ ) whose coefficient is the beam polarization
- Measure tau polarization as a function of  $\theta$  for the separately tagged beam polarization states
- Expect  $\sim 0.5\%$  absolute precision of the polarization at the interaction point – includes transport effects, lumi-weighting, stray  $e^+$  polarization
- Method assumes tau neutrino is 100% left handed – motivates validation of this



# Tau Polarization as Beam Polarimeter

---

- Advantages:
  - Measures beam polarization at the IP: biggest uncertainty in Compton polarimeter measurement is likely the uncertainty in the transport of the polarization from the polarimeter to the IP.
  - It automatically incorporates a luminosity-weighted polarization measurement
  - If positron beam has stray polarization, its effect is automatically included
- C. Miller (UVic) deployed this with *BABAR* data Preliminary (soon to be published) results with *BABAR*  $Y(4S)$  dataset ( $432\text{fb}^{-1}$ ) yield 0.3% combined statistical  $\oplus$  systematic uncertainty from only  $\tau \rightarrow \rho \nu$  with  $\tau \rightarrow (e/\mu)\nu\nu$  tag  
**See Caleb Miller's talk on Wednesday at 11:15am**

# SuperKEKB polarization upgrade

- Would aim to start to install polarization in Long Shutdown 2 (LS2) for new final focus ~2027, or later
- Polarization upgrade R&D in MEXT KEK Roadmap 2021-26

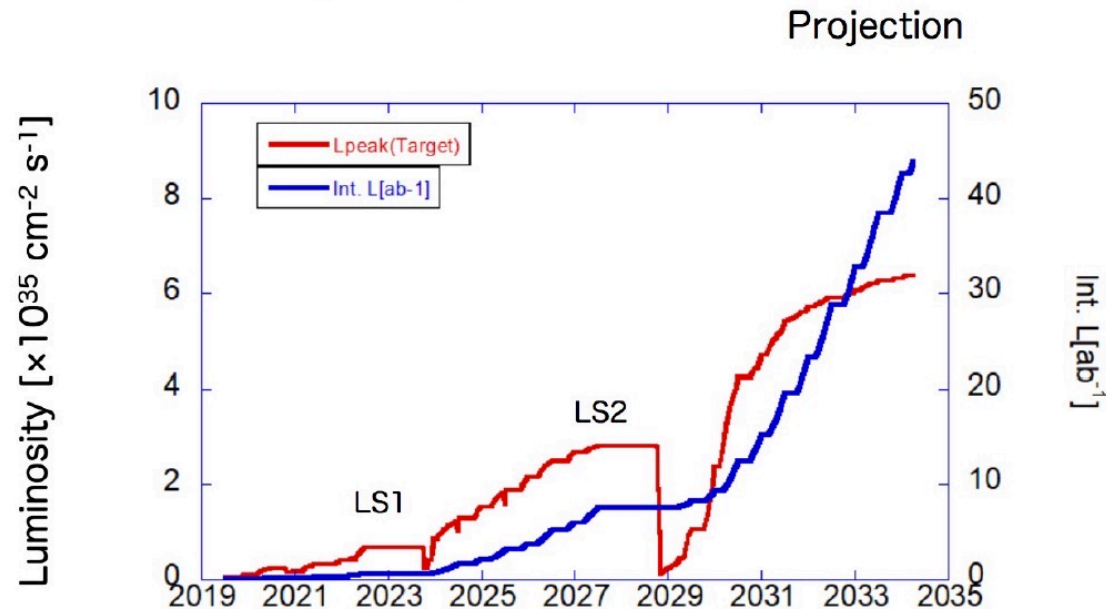

## LS2

- No sooner than 2026, more likely to start sometime in 2027
- IR modification
  - QCS, lattice
  - Belle modification might be needed

- Other (unknown) factors
- Long-term budget outlook
  - Electricity rate

June 2022 projections

# Summary

---

- $e^-$  polarization upgrade at SuperKEKB would open a unique discovery window with precision electroweak physics
  - Measure the b, charm, tau, muon vector couplings with the highest precision and competitive electron coupling measurement
  - Unique probe of universality at unprecedented precision
- Also get significant improvements to tau LFV, Michel parameters, LFV, EDM, and  $F_2(10\text{GeV})$

# Summary

- competitive with measurements at Z-pole (until FCC) but at 10.58 GeV and complementary to Moller and low energy PV
  - test running of couplings
  - probe new physics at TeV scale complementary to LHC
  - probe 'Dark Sector'

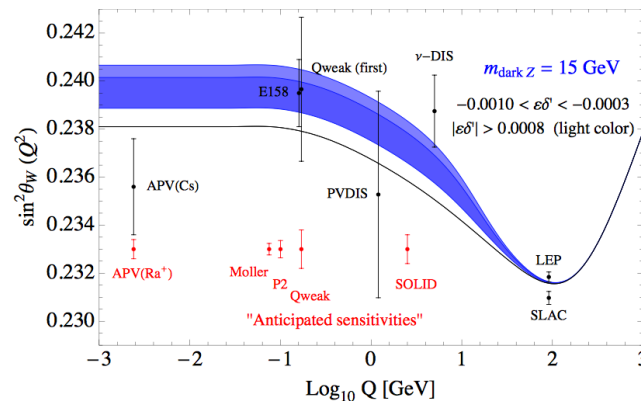

- Build on international partnerships with KEK to create a unique discovery machine

# Thankyou for your attention...

---

...and consider taking the plunge and join the SuperKEKB electron beam polarization project!

Many areas where new people can have an impact! Additional accelerator physicists, experimentalist and theorists very welcome

- Beam dynamics and spin tracking
- Spin rotator design
- Compton polarimetry – detector expertise
- Polarized low emittance source
- Tau decay polarimetry – use as many decay channels as possible
- Tau Michel parameter, EDM and  $F_2$  studies
- Detailed physics MC studies with final-state fermion selection  
optimizing signal to background: b, c, tau, mu and e, as well as light quarks
- Precision EW theoretical calculations
- Bhabha MC generator with polarized beams -> now have ReneSANCe

# Summary

---

By opening this *unique* window on New Physics we could find something REALLY exciting

...



# Additional Information

---

# Growing international collaboration of Accelerator and Particle Physicists ~ half from outside Belle II

- Canada: TRIUMF, UVic, Manitoba, UBC/IPP
- France: LAL/Orsay
- KEK & Hiroshima Univ. + Oide-san (CERN)
- Russia: BINP
- USA: ANL, BLN, Louisville, Duke

Theorists in Canada, Italy, Russia & U.S. published recently on physics enabled by this project

**Snowmass White Paper on Chiral Belle being used as basis for CDR which is being written & TDR, then construction.**

***Additional Attraction: Opportunity not just for physics, but serves as real-world project to develop technologies for learning and training for future e+e- polarization projects***



# Masanori Satoh, KEK (June 2020)

## Machine Parameters for KEKB/SuperKEKB

Stage	KEKB (final)		Phase-I		Phase-II		Phase-III (interim)		Phase-III (final)	
	e+	e-	e+	e-	e+	e-	e+	e-	e+	e-
Beam Energy	3.5 GeV	8.0 GeV	4.0 GeV	7.0 GeV	4.0 GeV	7.0 GeV	4.0 GeV	7.0 GeV	4.0 GeV	7.0 GeV
Stored current	1.6 A	1.1 A	1.0 A	1.0 A	-	-	1.8 A	1.3 A	3.6 A	2.6 A
Life time (min.)	150	200	100	100	-	-	-	-	6	6
	primary e- 10		primary e- 8						primary e- 10	
Bunch charge (nC)	→ 1	1	→ 0.4	1	0.5	1	2	2	→ 4	4
Norm. Emittance	1400	310	1000	130	200/40	150	150/30	100/40	<u>100/15</u>	<u>40/20</u>
( $\gamma\beta\epsilon$ ) ( $\mu\text{mrad}$ )					(Hor./Ver.)		(Hor./Ver.)	(Hor./Ver.)	(Hor./Ver.)	(Hor./Ver.)
Energy spread	0.13%	0.13%	0.50%	0.50%	0.16%	0.10%	0.16%	0.10%	<u>0.16%</u>	<u>0.07%</u>
Bunch / Pulse	2	2	2	2	2	2	2	2	2	2
Repetition rate	50 Hz		25 Hz		25 Hz		50 Hz		50 Hz	
Simultaneous top-up injection (PPM)	3 rings (LER, HER, PF)		No top-up		Partially		4+1 rings (LER, HER, DR, PF, PF-AR)		4+1 rings (LER, HER, DR, PF, PF-AR)	

# Comparing SAD FMA to BMAD FMA in original HER Lattice

Original HER Lattice with SAD

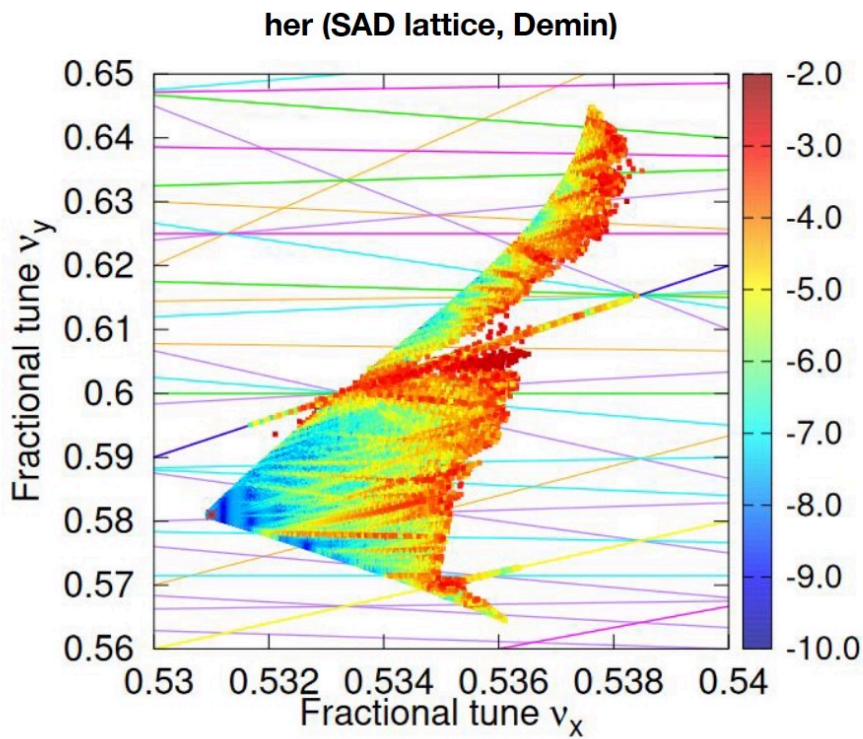

Original HER Lattice with BMAD

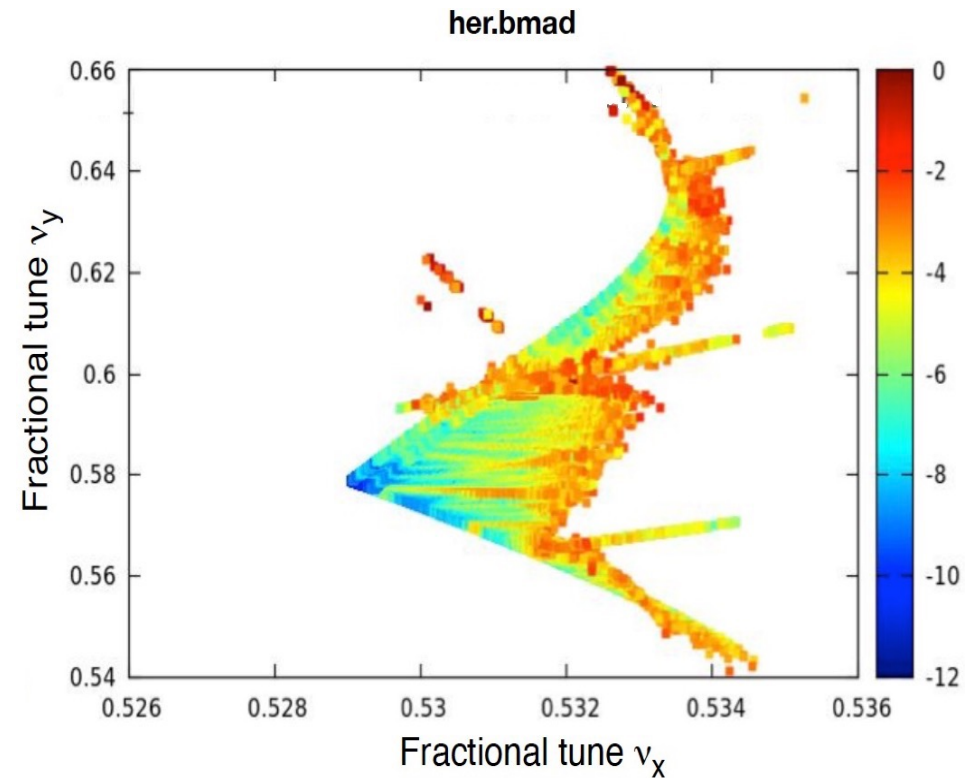

# Beam-Beam Effects on Polarization

---

The effect of beam-beam interactions on the polarization will have to be studied in simulations.

To 1<sup>st</sup>-order, the beam-beam effect is a focusing force that affects spin-transparency. At HERA it was observed that the optimum polarization at strong beam-beam required slightly different optimization of the machine but was recoverable to a large extent.<sup>1</sup>

Beam-beam in SuperKEKB will be stronger, but only by a modest factor, not by an order of magnitude as the luminosity is increased by extremely small, not by an extremely large, beam-beam parameter. We note that the beam-beam effects experienced by the electrons in HERA was not particularly small, due to the strong proton bunches, and was one of the factors limiting the luminosity.<sup>2</sup>

At SuperKEKB, with short beam lifetime and constant injection of freshly polarized electrons, a high equilibrium polarization is a realistic expectation.

1. M. Boge and T. Limberg, Conf. Proc. C 950501, 2901 (1996); M. Bieler *et al.*, in “Workshop on Beam-Beam Effects in Large Hadron Colliders” (1999) pp.12-19.
2. J. Shi, L. Jin, and G. Hoffstaetter, Conf.Proc.C 030512 (2003), 369, (2003)

# Electric and magnetic moments of $\tau$ lepton

Charge asymmetry along spin direction: EDM  $\neq 0 \Rightarrow$  CP violation  
 SM expectation  $\mathcal{O}(10^{-37})$  e.cm far below experimental sensitivity  
 New physics in loops can enhance EDM of  $\tau$  lepton  $\sim \mathcal{O}(10^{-19})$  e.cm

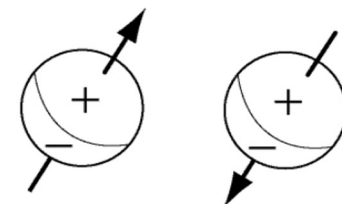

W. Bernreuther et. al. Phys. Lett. B 391, 413 (1997); T. Huang et. al. Phys. Rev. D 55, 1643 (1997).

$$a_\ell = (g_\ell - 2)/2$$

Large deviation in anomalous magnetic moment of muon:

$$a_\mu^{\text{exp}} - a_\mu^{\text{SM}} = (251 \pm 59) \times 10^{-11} [4.2\sigma]$$

Expectation from Minimal flavor violation:

$$a_\tau^{\text{BSM}} \sim a_\mu^{\text{BSM}} \left( \frac{m_\tau}{m_\mu} \right)^2 \sim 10^{-6}$$

Current bound in tau  $\sim \mathcal{O}(10^{-2})$

Chiral Belle reach  $\sim \mathcal{O}(10^{-5})$  with 50ab<sup>-1</sup>

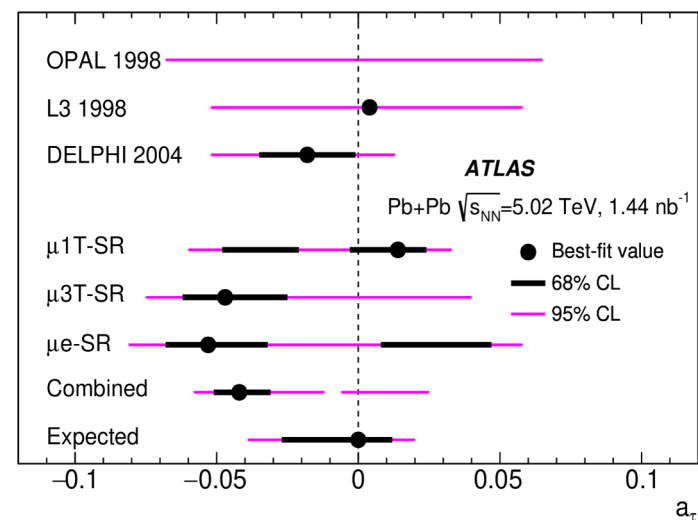
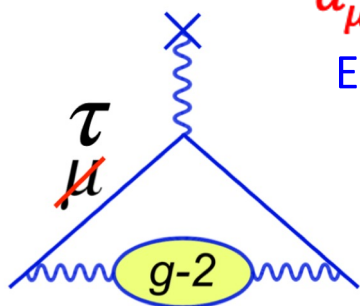

e-Print: 2204.13478 [hep-ex]  
 ATLAS Collaboration

## Effective field theory approach to $\tau$ -pair production

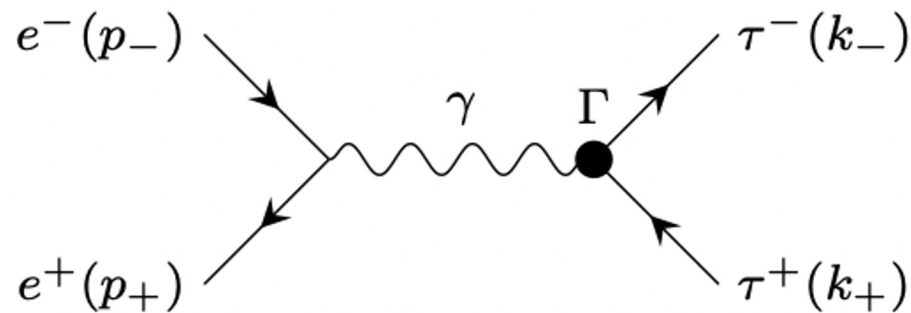

$$\Gamma^\mu = \underbrace{F_1(q^2) \gamma^\mu}_{\text{radiative corrections}} + \underbrace{F_2(q^2) \frac{1}{2m_\tau} \mathbf{i} \sigma^{\mu\nu} q_\nu}_{\text{MDM}} + \underbrace{F_3(q^2) \frac{1}{2m_\tau} \sigma^{\mu\nu} q_\nu \gamma_5}_{\text{EDM}}$$

- ▶  $F_1(q^2)$ ,  $F_2(q^2)$  are called the Dirac and Pauli;  $F_1(0) = 1$ ;  $F_2(0) = a_\tau$  **Leading**
- ▶  $g = 2 \cdot [F_1(0) + F_2(0)] = 2 + 2F_2(0)$   $d_\tau^\gamma = \frac{e}{2m_\tau} \cdot F_3(0)$  **term**

$$\frac{\alpha}{2\pi}$$

$$\approx 0.001\,161\,4$$

# Magnetic dipole moments of $\tau$ lepton

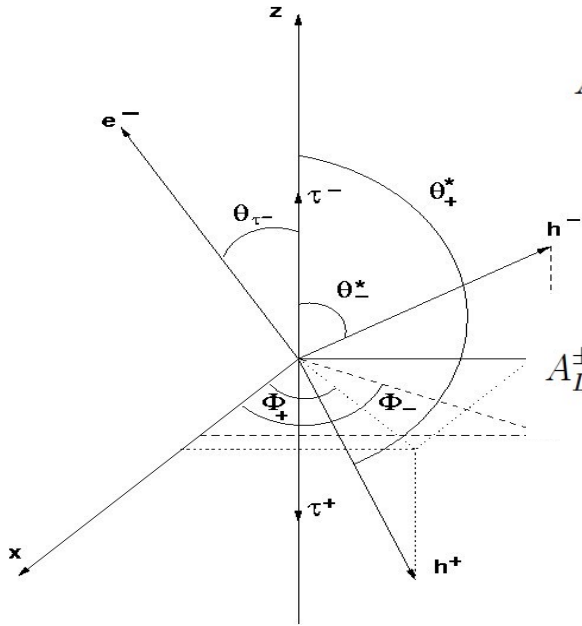

$$A_T^\pm = \frac{1}{2\sigma} \left[ \int_{-\pi/2}^{\pi/2} \left( \left( \frac{d\sigma^{Re}}{d\phi_\pm} \right) - \left( \frac{d\sigma^{Le}}{d\phi_\pm} \right) \right) d\phi_\pm - \int_{\pi/2}^{3\pi/2} \left( \left( \frac{d\sigma^{Re}}{d\phi_\pm} \right) - \left( \frac{d\sigma^{Le}}{d\phi_\pm} \right) \right) d\phi_\pm \right]$$

$$A_L^\pm = \frac{1}{2\sigma} \left[ \int_0^1 dz_\pm^* \left( \int_0^1 dz (A_{RL}) - \int_{-1}^0 dz (A_{RL}) \right) - \int_{-1}^0 dz_\pm^* \left( \int_0^1 dz (A_{RL}) - \int_{-1}^0 dz (A_{RL}) \right) \right]$$

$$A_{RL} = \frac{d^2\sigma^{Re}}{dz_\pm^* dz} - \frac{d^2\sigma^{Le}}{dz_\pm^* dz}$$

$$\text{Re}(F_2^{\text{eff}}) = \mp \frac{8(3 - \beta^2)}{3\pi\gamma\beta^2\alpha_\pm} \left( A_T^\pm - \frac{\pi}{2\gamma} A_L^\pm \right)$$

requires precision  $E_{\text{cm}}$  &  $m_\tau$   
 $F_1$  cancellation

## Electric dipole moments of $\tau$ lepton

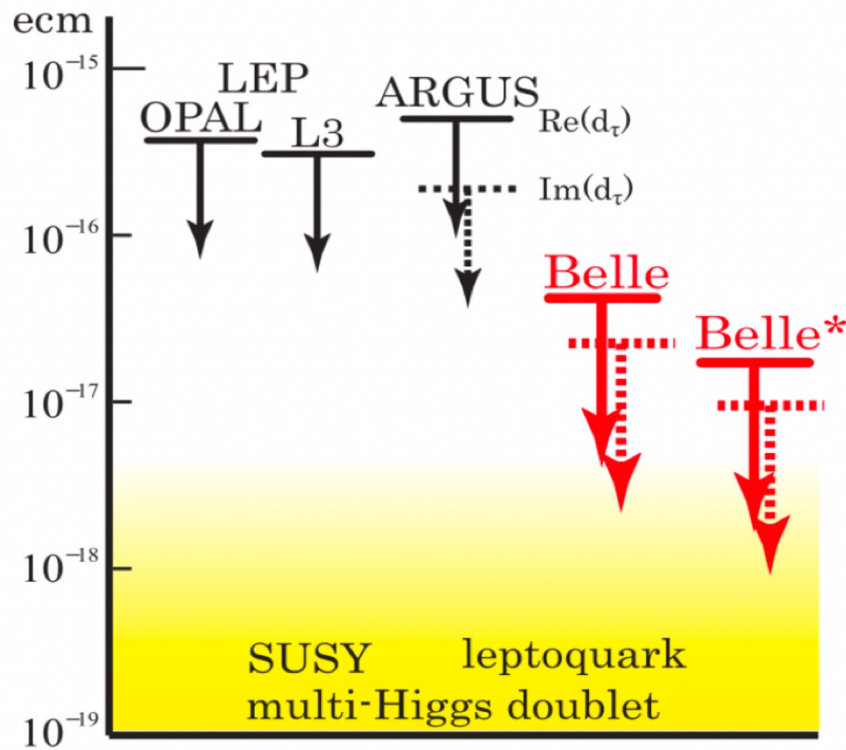

Belle; 833 fb-1 data (arXiv:2108.11543 [hep-ex])

$$\text{Re}(d_\tau) = (-0.62 \pm 0.63) \times 10^{-17} \text{ ecm},$$

$$\text{Im}(d_\tau) = (-0.40 \pm 0.32) \times 10^{-17} \text{ ecm}.$$

– 95% confidence intervals

$$-1.85 \times 10^{-17} < \text{Re}(d_\tau) < 0.61 \times 10^{-17} \text{ ecm},$$

$$-1.03 \times 10^{-17} < \text{Im}(d_\tau) < 0.23 \times 10^{-17} \text{ ecm}.$$

- Consistent with zero EDM
- Systematic errors similar to statistical
- Dominant systematics: Data-MC mismatch in momentum/angular distributions

- Preliminary studies at Belle II show much better control in agreement between Data-MC
- After improved control of systematics, extrapolation based on statistical errors only
- **With 50  $\text{ab}^{-1}$  data at Belle II:  $\text{Re}(d_\tau) \sim 8 \times 10^{-19}$ ,  $\text{Im}(d_\tau) \sim 4 \times 10^{-19}$**
- Further improvement expected from proposed upgrade of polarized e- beams.

# $\tau$ Michel Parameter with polarized e- beam (from Denis Epifanov's Tau2021 talk on STCF)

## Fit of $(\rho, \text{all})$ in 3D at Belle II and SCTF

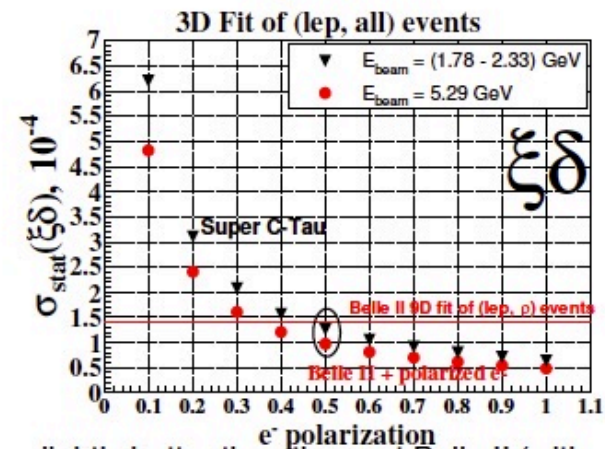
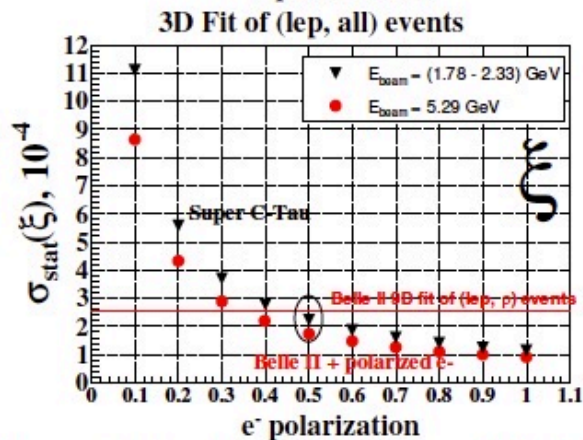
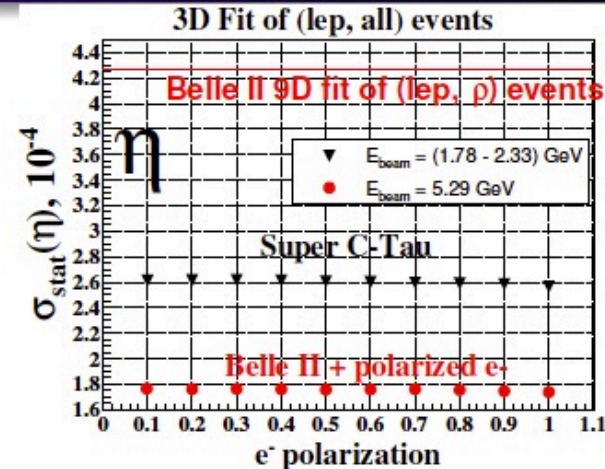
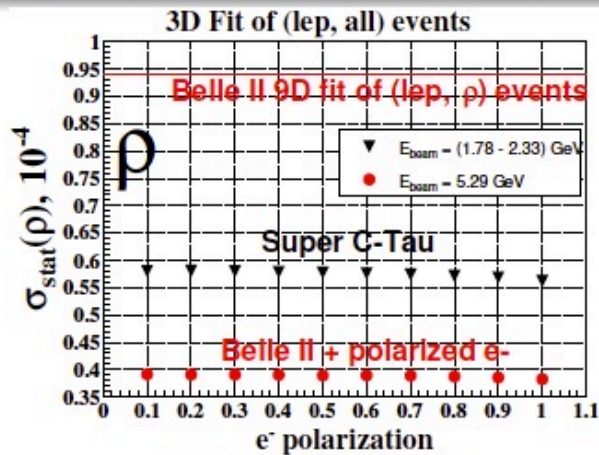

The sensitivities to all Michel par. at the SCTF become slightly better than those at Belle II (with unpolarized  $e^-$  beam) for  $P_e > 0.5$ .

Expected MP stat. uncertainties are  $\sim 10^{-4}$ , to reach the same level systematic uncertainty, the NNLO corrections ( $\mathcal{O}(\alpha^4)$ ) to the differential  $e^+e^- \rightarrow \tau^+\tau^-$  cross section are mandatory.

It would be very exciting to have both projects probing tau sector with polarized e- beams

50/ab of polarized Belle II data assumed in these studies



## Search for lepton flavor violation in $\tau$ decays

- Belle II to probe LFV in several channels  $\simeq \mathcal{O}(10^{-10})$  to  $\mathcal{O}(10^{-9})$  with  $50 \text{ ab}^{-1}$
- With beam polarization, helicity distributions can suppress backgrounds
- Optimization study shows at least 10% improvement in  $\tau \rightarrow \ell \gamma$  sensitivity

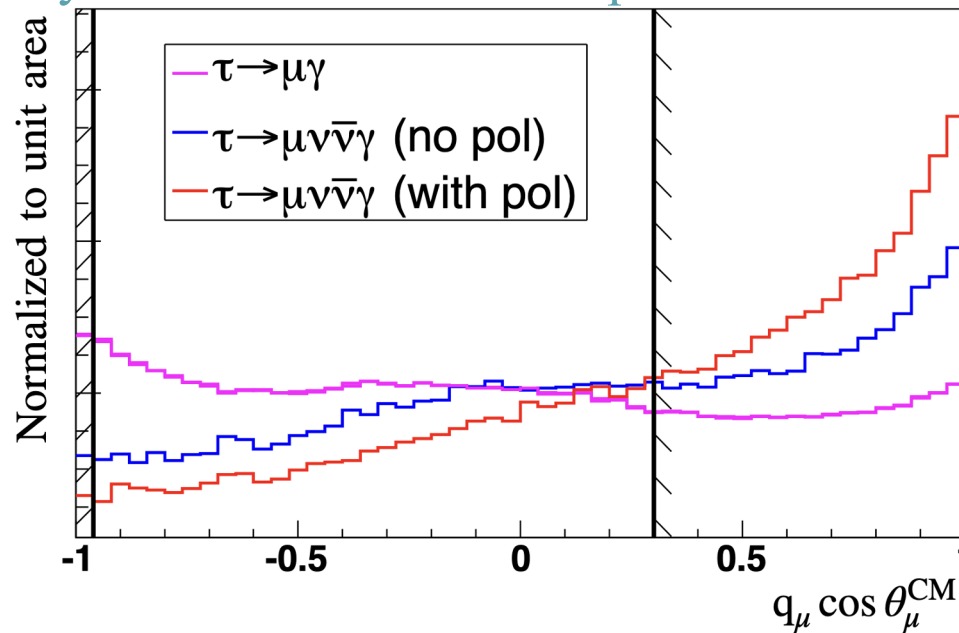

- Possible to disentangle helicity structure of LFV in  $\tau \rightarrow \ell \ell \ell$  from Dalitz plots

# Upgrading SuperKEKB with e- Polarized Beams: Chiral Belle $\rightarrow$ unique probe of New Physics

## Chiral Belle Precision electroweak measurements

Final State Fermion	$A_{LR}^{SM}$	Relative $A_{LR}$ Error (%)	$g_V^f$ W.A.[1]	$\sigma(g_V^f)$ (20 ab $^{-1}$ )	$\sigma(g_V^f)$ (40 ab $^{-1}$ )	$\sigma(s^2\theta_W)$ (40 ab $^{-1}$ )
b-quark (eff.=0.3)	-0.020	0.4	-0.3220 $\pm 0.0077$	0.002 improves x4	0.002	0.003
c-quark (eff.=0.15)	-0.005	0.5	+0.1873 $\pm 0.0070$	0.001 improves x7	0.001	0.0008
tau (eff.=0.25)	-0.0006	2.4	-0.0366 $\pm 0.0010$	0.001	0.0008	0.0004
muon (eff.=0.5)	-0.0006	1.5	-0.03667 $\pm 0.0023$	0.0007 improves x3	0.0005	0.0003
electron (17nb acceptance, eff=.36)	+0.00015	2.0	-0.3816 $\pm 0.00047$	0.0009	0.0006	0.0003

Table 1: For each fermion pair cleanly identifiable in Belle II for the given efficiency in column 1: column 2 gives the SM value of  $A_{LR}$ ; column 3, the expected relative error on  $A_{LR}$  based on based on 40 ab $^{-1}$  and a beam polarization at Belle II of  $0.700 \pm 0.003$  with an error of  $\pm 0.003$ ; column 4, the current world average value of its neutral current vector coupling; column 5, the projected error on  $g_V^f$  with 20 ab $^{-1}$  of data; column 6, the projected error on  $g_V^f$  with 40 ab $^{-1}$  of data; and column 7, the projected SuperKEKB/Belle II error on  $\sin^2 \theta_W^{eff}$  with 40 ab $^{-1}$  of polarized  $e^-$  beam data.

**From: Snowmass 2021 White Paper**

**Upgrading SuperKEKB with a Polarized Electron Beam:**

**Discovery Potential and Proposed Implementation**

**arXiv:2205.12847**

# Polarization in SuperKEKB

Zachary J. Liptak (Hiroshima U.)

## Polarized Source Development

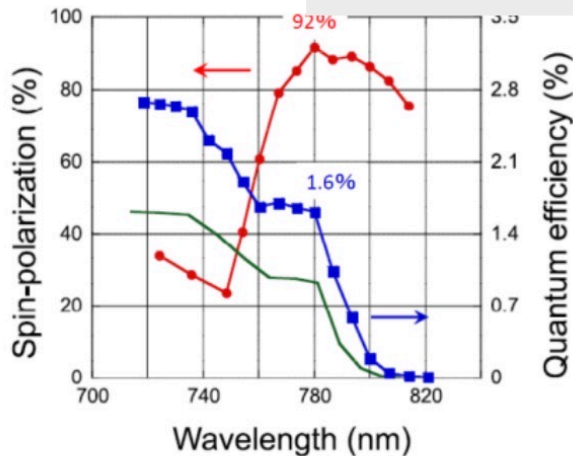

GaAs cathodes can produce beams with >90% polarization and ~1.6% QE, but due to a wide band gap accelerating electrons is difficult

Effect of crystal quality on performance of spin-polarized photocathode  
 Xiuguang Jin, Burak Ozdol, Masahiro Yamamoto, Atsushi Mano, Naoto Yamamoto, and Yoshikazu Takeda  
 Citation: Applied Physics Letters 105, 203509 (2014); doi: 10.1063/1.4902337

We can alleviate this problem by applying a thin Negative-Electron Affinity (NEA) film on the surface to shrink the band gap and impart some energy to the freed electrons.

Lifetimes of these cathodes are currently too short to be practically useful now and we are trying to improve them.

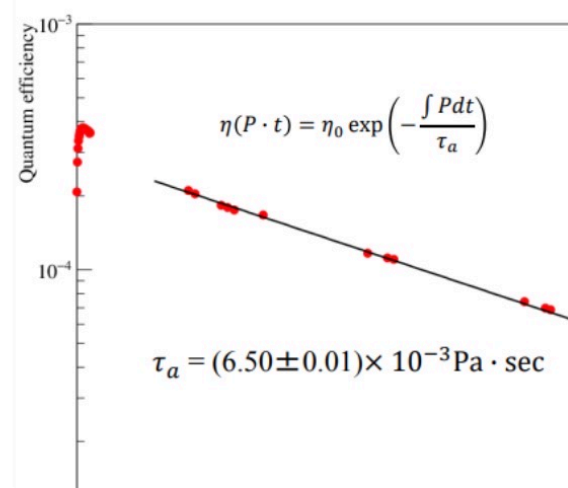
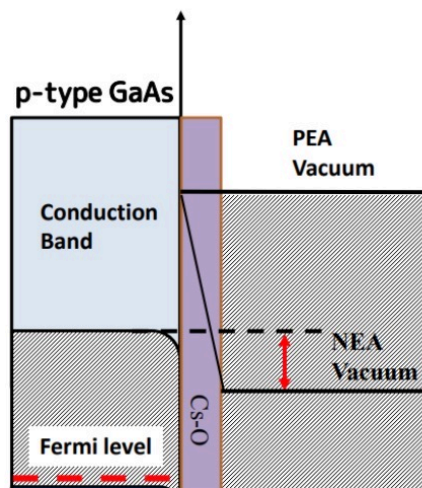

Cathodes	Lifetime $\tau_a$ [ $10^{-3} \text{ Pa} \cdot \text{sec}$ ]
CsKTe/GaAs	$6.50 \pm 0.01$
Cs-O/GaAs	$0.29 \pm 0.03$ [1]
Cs-O/GaAs	$0.40 \pm 0.02$ [2]

[1]K. Miyoshi, M. Thesis, Hiroshima U. (2013)  
 [2]G. Lei, M. Thesis, Hiroshima U. (2014)

# Preliminary studies by BINP group

---

## **BINP Concepts: install spin-rotator magnets in drift regions**

Introduce modest conversion of the geometry of electron beam bends in the experimental section of the HER storage ring to provide drift gaps with a length of about 10m for installing spin rotators. Requires repositioning of some magnets in ring.

Two concepts explored:

- i) first approach uses a conventional spin rotator with separate solenoid and quadrupole magnets;
- ii) second approach makes use of combined function solenoid-quadrupole magnets  
This is favoured as it involves lower solenoid fields

From I. Koop, A.Otboev and Yu.Shatunov, BINP, Novosibirsk preliminary considerations on the longitudinal polarization at SuperKEKB

# BINP Spin Rotator Concept

A scheme with restoration of the vertical spin direction in main arcs

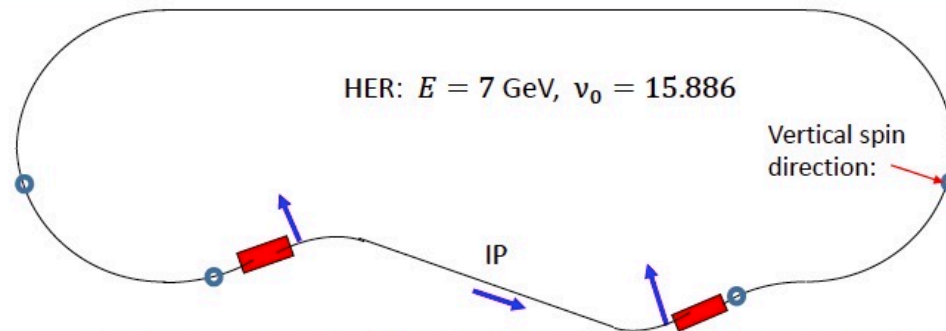

Spin direction is vertical in the main part of HER. Then it is rotated to the horizontal plane by the set of two solenoids, which are comprising the  $90^\circ$  spin rotator.

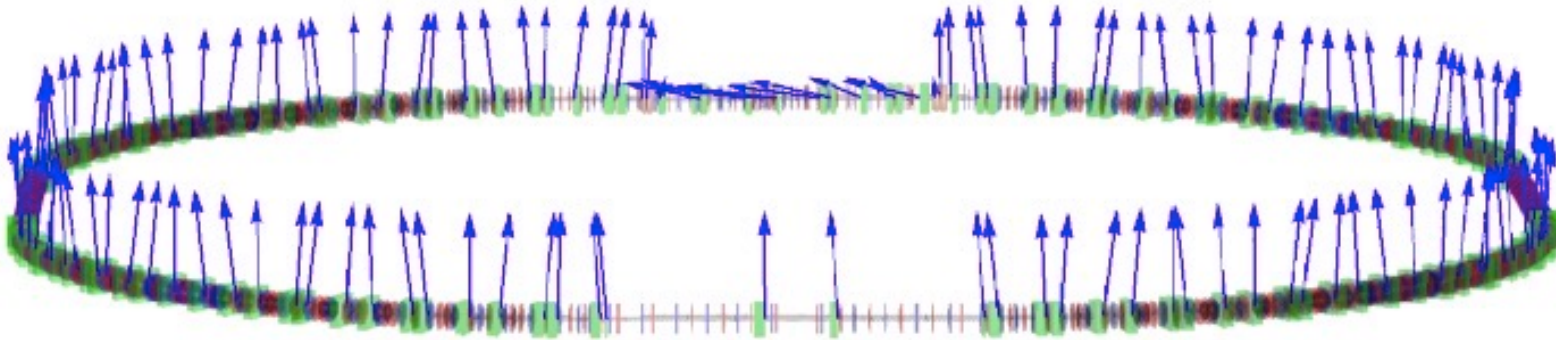

This antisymmetric layout (the S curve through the IP) preserves "strong spin-matching", i.e. minimizes the change of spin-phase advance with beam energy through the total rotator section (because the two rotators cancel each other)

From I. Koop, A.Otboev and Yu.Shatunov, BINP, Novosibirsk preliminary considerations on the longitudinal polarization at SuperKEKB

# Preliminary studies by BINP group

$n_0$  along machine,  $E = 7.15 \text{ GeV}$ , HER, IP region

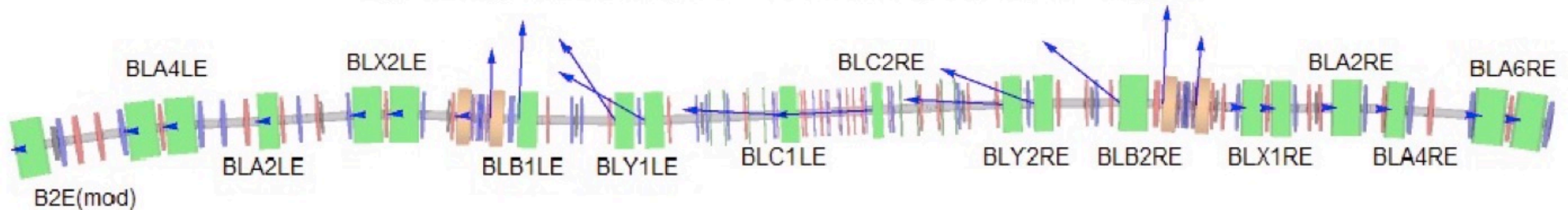

"B2E(mod)"	"BLA2LE"	"BLA2RE"	"BLA4LE"	"BLA4RE"	"BLA6RE"	"BLB1LE"
0.0745895	-0.0181419	0.0591537	0.0520765	0.0280687	0.0501498	-0.0368136
"BLB2RE"	"BLC1LE"	"BLC2RE"	"BLX1RE"	"BLX2LE"	"BLY1LE"	"BLY2RE"
0.0548871	-0.00591049	0.0059199	-0.0310501	0.0570931	-0.0270415	0.018

In arcs spin is directed purely vertically, while at IP longitudinally.

From I. Koop, A. Otboev and Yu. Shatunov, BINP, Novosibirsk preliminary considerations on the longitudinal polarization at SuperKEKB

# Preliminary studies by BINP group

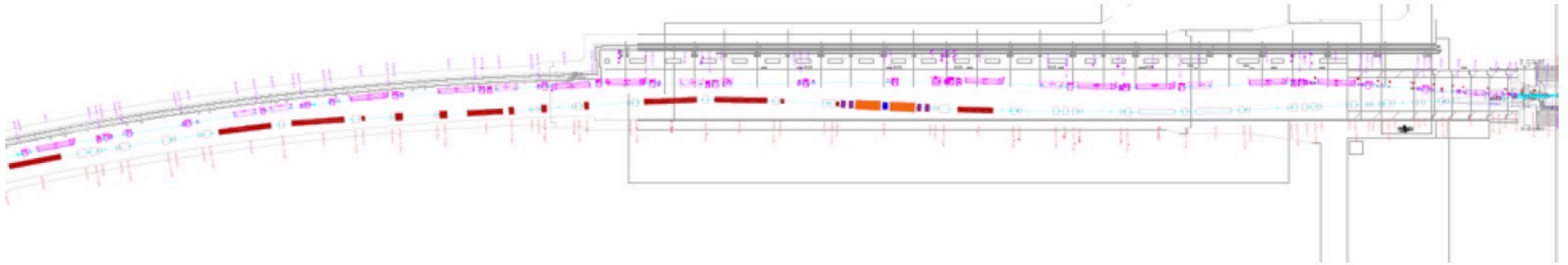

Figure 18: To the left from the IP half of experimental straight section. The modified magnetic elements of the HER ring are painted in dark brown, and the solenoids of the spin rotator are painted in dark yellow. The distance between the rings is great

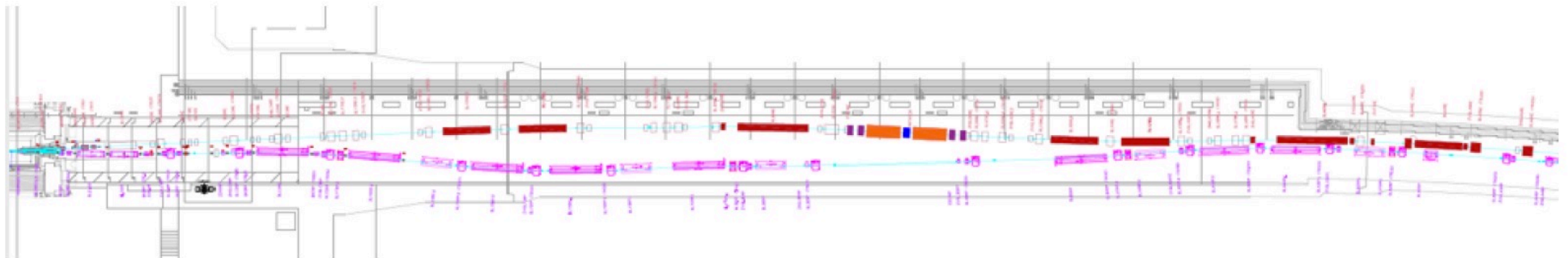
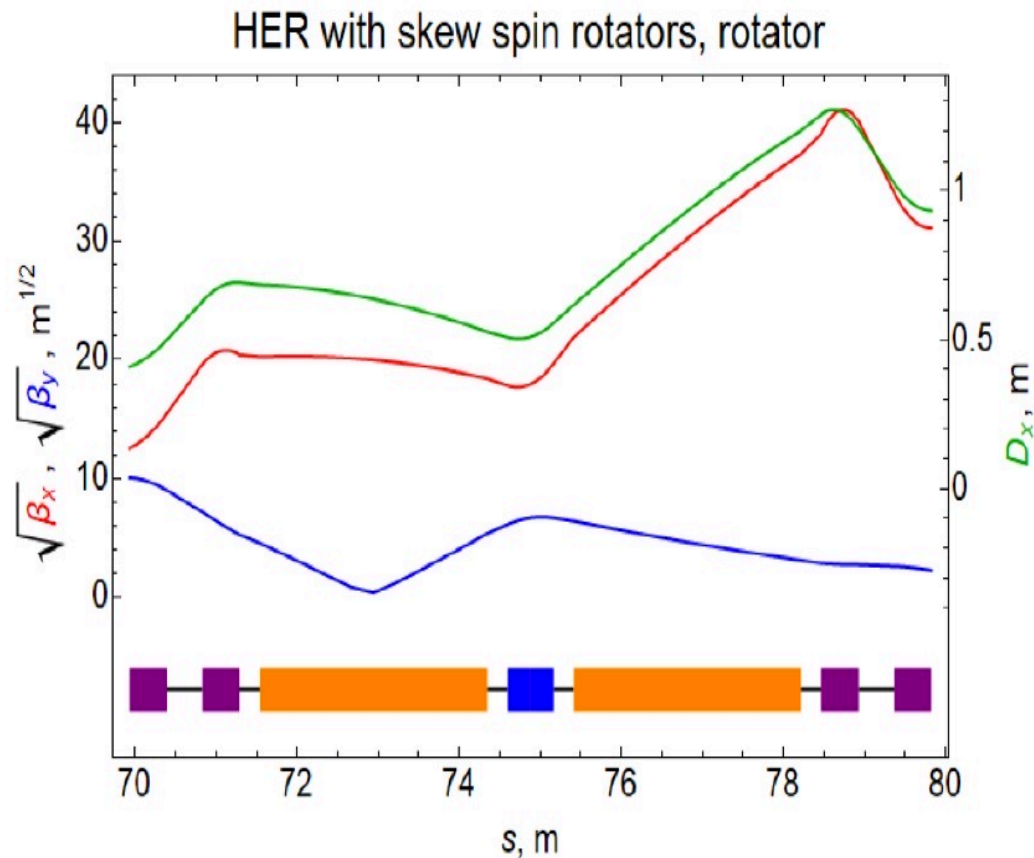

Figure 19: To the right from the IP half of straight section. At the entrance to the tunnel, the magnets of the rings are very close, but such technical problems can be solved.

# Preliminary studies by BINP group



e.g. Lattice functions for left-side spin rotator. Solenoids orange, central quad is normal, while doublets are rolled anti-symmetrically by  $\varphi = \pm 22.474^\circ$ .

Figure 21: Optical functions of the spin rotator for the left half of the long interaction region.

From I. Koop, A.Otboev and Yu.Shatunov, BINP, Novosibirsk preliminary considerations on the longitudinal polarization at SuperKEKB



# Preliminary studies by BINP group: option (i)

Element	Length, m	Field or Gradient: T, T/m
Quadrupole #1, #5	0.46227	-29.4792 ( $\phi_1 = -\phi_5 = -22.474^\circ$ )
Drift 1	0.436	
Quadrupole #2, #4	0.46227	28.5569 ( $\phi_2 = -\phi_4 = -22.474^\circ$ )
Drift 2	0.25	
Solenoid	2.8	6.54197
Drift 3	0.25	
Quadrupole #3	0.57004	-25.3736 ( $\phi_3 = 0$ )

Table 12: Basic parameters of lenses and solenoids for BR = 23.3495 T·m (E = 7.15 GeV).

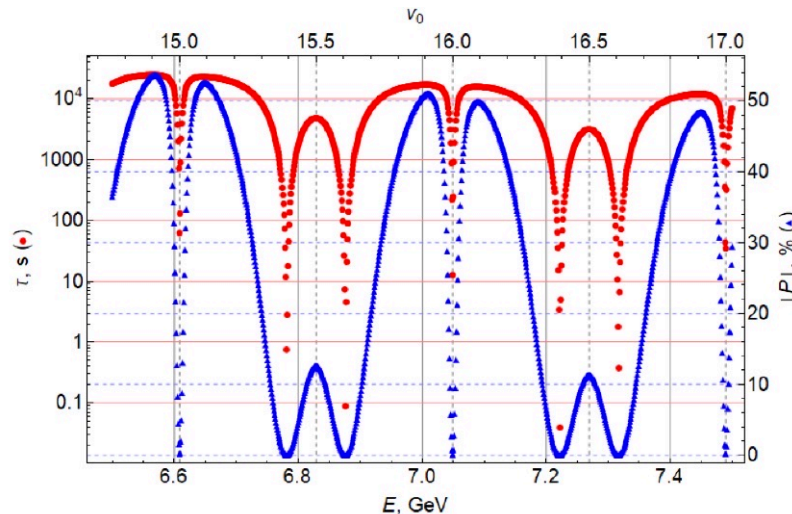

Figure 23: Dependence of the radiation spin relaxation time on energy with the rotator version from Table 12 with rotated extreme doublets of the lenses, see Fig. 21.

From I. Koop, A.Otboev and Yu.Shatunov, BINP, Novosibirsk preliminary considerations on the longitudinal polarization at SuperKEKB

Name	Quantity	Original parameters of dipoles		New parameters	
		Length, m	Angle, rad	Length, m	Angle, rad
B2E.4	1	5.90220	0.0557427	5.90220	0.0745895
BLA4LE	2	5.90220	0.0663658	5.90220	0.0520765
BLA2LE	1	5.90220	0.0206421	<b>3.96143</b>	-0.0181419
BLX2LE	2	3.96143	0.0259281	<b>5.90220</b>	0.0570931
BLB1LE	1	3.96143	-0.0229996	3.96143	-0.0368136

Table 10: Lengths and rotation angles of the dipoles to the left of the intersection of the beams.

Name	Quantity	Original parameters of dipoles		New parameters	
		Length, m	Angle, rad	Length, m	Angle, rad
BLA6RE	2	5.90220	0.0501497	5.90220	0.0501498
BLA4RE	1	5.90220	0.0480687	<b>3.96143</b>	0.0280687
BLA2RE	1	3.96143	0.0348280	<b>5.90220</b>	0.0591537
BLX1RE	2	3.96143	-0.0221788	3.96143	-0.0310501
BLB2RE	1	3.96143	0.0234696	<b>5.90220</b>	0.0548871
BLY2RE	2	3.96143	0.0270000	3.96143	0.0180000

Table 11: Lengths and rotation angles of the dipoles to the right of the intersection of the beams.

**Depolarization  
lifetime at E=7.15GeV  
is ~10000s (~3 hrs)**

**Note: beam is  
topped-up @ 50Hz  
continuously  
(current beam lifetime  
without top-up <1hr)**

# Preliminary studies by BINP group: option (ii)

Element	Length, m	Field or Gradient: T, T/m
Drift #1, #17	0.34556	$B_s = G = 0$
Pure Solenoid #2, #16	0.15	$B_s = 4.067373$
Quadrupole plus Solenoid: #3, #15	0.7	$-20.067768$ ( $\phi_3 = -\phi_{15} = -19.822^\circ$ )
Solenoid #4, #14	0.4	$B_s = 4.067373$
Quadrupole plus Solenoid: #5, #13	0.7	$23.232294$ ( $\phi_5 = -\phi_{13} = -14.5297^\circ$ )
Solenoid #6, #12	0.8	$B_s = 4.067373$
Quadrupole plus Solenoid: #7, #11	0.7	$-5.385630$ ( $\phi_7 = -\phi_{11} = -7.3598^\circ$ )
Solenoid #8, #10	0.8	
Quadrupole plus Solenoid: #9	0.7	$-22.806964$ ( $\phi_9 = 0^\circ$ )

Table 13: Basic parameters of lenses and solenoids of a spin rotator with a superposition of solenoidal and quadrupole fields for BR = 23.3495 T·m (E = 7.15 GeV). The sequence of numbering of structure elements: 1, 2, ..., 17.

Element	Length, m	Field or Gradient: T, T/m
Drift #1, #17	0.34556	$B_s = G = 0$
Solenoid: #2, #16	0.35	$B_s = 5.15983$
Quadrupole: #3, #15	0.3	$-41.5055$ ( $\phi_3 = -\phi_{15} = -20.25818^\circ$ )
Solenoid #4, #14	0.8	$B_s = 5.15983$
Quadrupole: #5, #13	0.3	$45.5005$ ( $\phi_5 = -\phi_{13} = -15.19364^\circ$ )
Solenoid #6, #12	1.2	$B_s = 5.15983$
Quadrupole: #7, #11	0.3	$-7.56501$ ( $\phi_7 = -\phi_{11} = 7.59682^\circ$ )
Solenoid #8, #10	1.2	$5.15983$
Quadrupole: #9	0.3	$-53.2734$ ( $\phi_9 = 0^\circ$ )

Table 14: Parameters of lenses and solenoids of a spin rotator with alternating solenoidal and quadrupole fields for BR = 23.3495 T·m (E = 7.15 GeV).

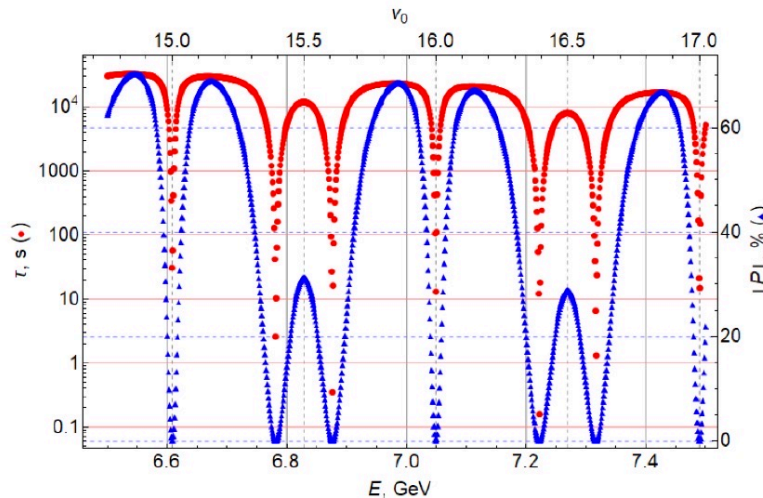

Figure 26: Radiation spin relaxation time and equilibrium degree of polarization versus energy for the rotator optics option from Table 14.

From I. Koop, A. Otboev and Yu. Shatunov, BINP, Novosibirsk preliminary considerations on the longitudinal polarization at SuperKEKB

**Depolarization  
lifetime at E=7.15GeV  
is ~19000s**

**Note: beam is  
topped-up @ 50Hz  
continuously  
(current beam lifetime  
without top-up <1hr)**