

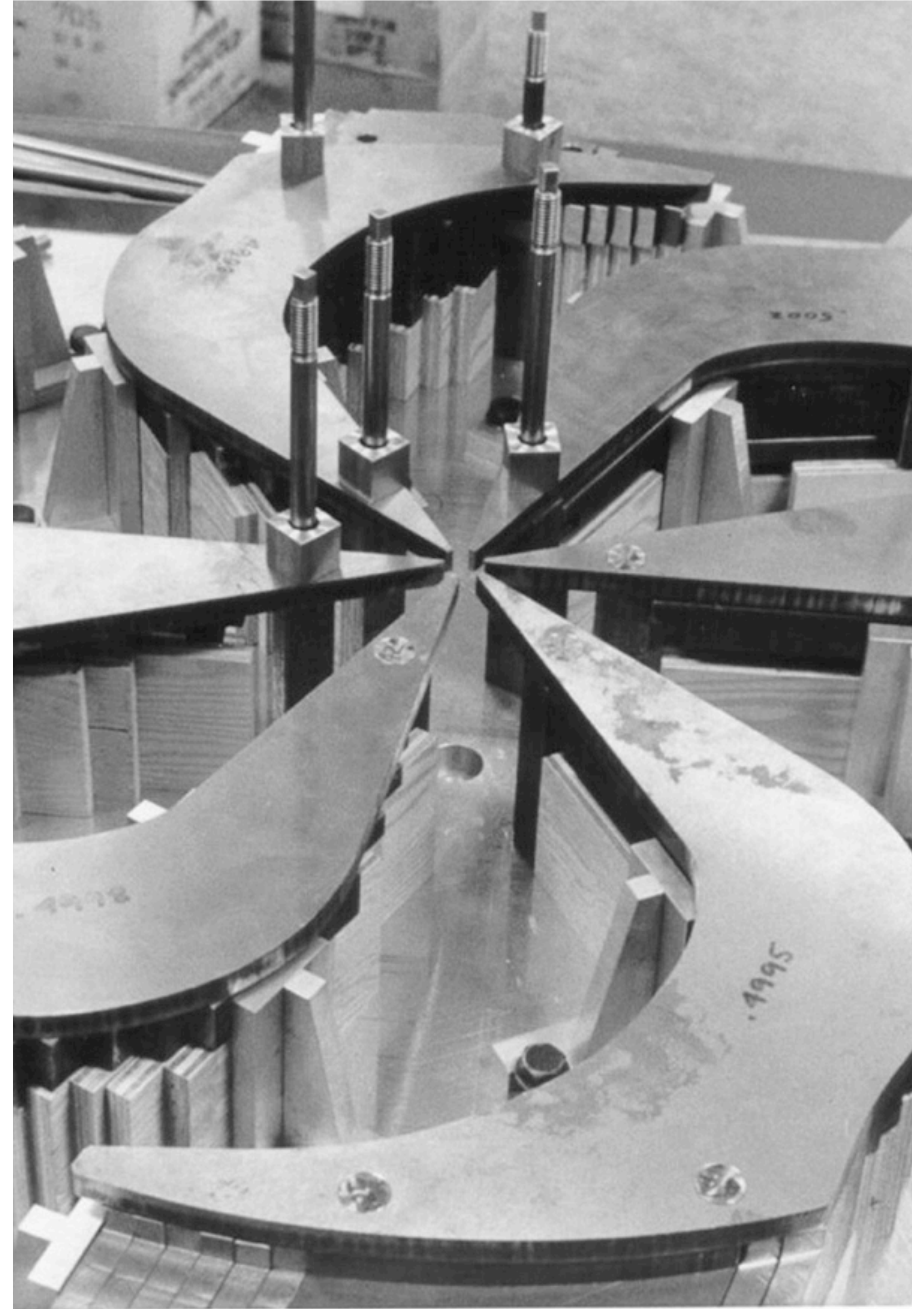

# Five-year proposal planning and PP Centres

Nigel J.T. Smith  
Oliver Stelzer-Chilton

IPP AGM  
2023-06-23



**Discovery,  
accelerated**

# Five-year Plan/Proposal Process

- Previous iterations of 5YP blended strategic planning, future vision and next five year proposal. Last four iterations were not funded as requested - usually flat-flat plus one-off deferred maintenance injections
  - Strategic and Implementation plans were not adjusted for funded levels, and no follow up with stakeholders to define programme achievable with secured funding.
  - Creates risk through mismatch of expectation
- Next submission is a new paradigm - 20-vision done, collating community and lab ideas, setting the general parameters for a five-year proposal submission
  - Time of flux for operational support to the Major Research Facility programme (discussion of TRIUMF moving from NRC stewardship to ne MRF proposal: risks identified and discussed with ISED/CFI/NRC)
  - The process is not fully defined, but aiming for submission for budget 2024, and will allow TRIUMF and NRC to advocate for the request
  - Break the link between proposal & strategy to give flexibility (iterations after funding is secured)

# History & Process

In addition to setting the strategic priorities for TRIUMF, the 5-Year Plan also forms the basis of TRIUMF's funding request for core operational support from the federal government.

## 5-Year Plan 2005 – 2010:

- Targeted funding: \$276.9M
- Funding received: \$222.3M

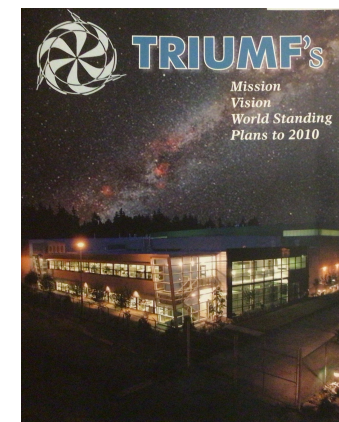

## 5-Year Plan 2015 – 2020:

- Targeted funding: \$290M
- Funding received: \$267.3M\*\*

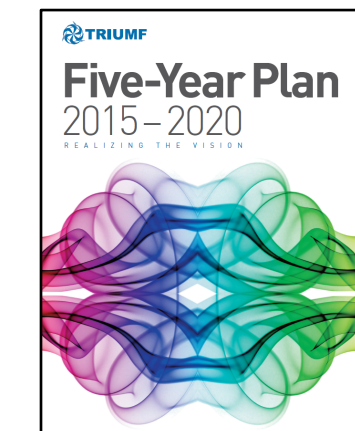

## 5-Year Plan 2010 – 2015:

- Targeted funding: \$328M\*
- Funding received: \$222.3M



## 5-Year Plan 2020 – 2025:

- Targeted funding: \$320M
- Funding received: \$292.7M\*\*\*



\* This request included funding for several projects that would later be supported through the CFI Innovation Fund, including ARIEL and the ATLAS Tier-1

\*\* This funding was allocated in two tranches beginning with an initial \$222.3M commitment in 2014, followed by a \$45M supplement in 2015

\*\*\* Finance Canada arrived at this value by starting with the flat-flat amount of \$267.3M and adding a one-time increase of ~\$25M for critical capital projects and deferred maintenance

# TRIUMF's 5-Year Plan Documentation

	Lead-up	Pre-Budget	Post-Budget
Actual 5-Year Plan 2020 – 2025 Process	None	Strategic Plan Implementation Plan Assorted summary and pitch documents (i.e. 1-3 pagers, memos, etc.)	<i>Internal planning only</i>
Proposed 5-Year Plan 2025 – 2030 Process	20-Year Vision	Funding proposal document for government High-level glossy pitch document Assorted summary and pitch documents (i.e. 1-3 pagers, memos, etc.)	Strategic Plan

# Workflow

- Many related tasks already completed to provide framework, context and content
- Scenario planning underway currently, leading to proposal construction
- Funded fine-year plan to be constructed after award

		Leads	Engaged	Outcome	Completed?
Community Requirements	20YV: Community Topical Groups	Divisions	TRIUMF Divisions Community Steering Committee	Vision frameworks Topical group outputs	Yes
	20YV: Vision Framework 20-year Vision	DDR DDR/ED	Community Board of Governors	Vision frameworks TRIUMF 20-year vision	Yes Yes
Framework	NRC OAE Evaluation	NRC	TRIUMF Divisions Community	Evaluation report	Yes*
	Community alignment to Long Range Plan, strategic plans for stakeholder groups	Leadership Team	Community Science Week	Alignment to 20-year Vision	Yes
	MRF Framework discussions	ED/CoS	ISED/NRC	Understanding of scope and framework	Yes*/ Ongoing
Contents and Scenarios	Staff compensation model	ED/HR Leadership	Consultants	Compensation model	Yes
	Long term objective setting	Team	TRIUMF Divisions	Resource spreadsheet	Yes
	Resource requirement setting based on objectives	Leadership Team	TRIUMF Divisions	Resource spreadsheet Priorities and scenario	Yes
	Scenario planning	ED	Leadership Team	planning	In progress
5-year Proposal	Proposal construction	ED	Leadership Team	5-year proposal	Initiated
	Proposal dissemination	ED/CoS	Leadership Team	Socialisation of proposal	No
	Proposal submission	NRC	ED	Submission to government	No
<b>After award</b>					
5-year Plan	Comparison to proposal	Divisions	TRIUMF Divisions TRIUMF Divisions	Framework document	No
	5-year Plan Construction	ED	Community	5-year Strategic Plan	No
	5-year Plan Approval	ED/CoS	Board of Governors	5-year Strategic Plan	No

# Key Themes of the Proposal

- Completion and operation of major platforms to deliver new science
  - Complete ARIEL and IAMI, initial operation phases
- Talent attraction and retention
  - Aligning compensation to market requirements, attracting international experts
- Regulatory compliance and operational excellence
  - New requirements being placed on TRIUMF (CNSC, EGBC, NRC, ...)
- Deferred maintenance
  - Major components (electrical substation, BL1A, ...)
- Scientific programme alignment to 20-year Vision
  - Development of research centres for new initial thrusts in the vision

# Work in Progress

- Proposal framework is completed, construction underway
- Will articulate various scenarios and ensure clear understanding of flat-flat and flat scenarios
- Work with NRC on strategic positioning

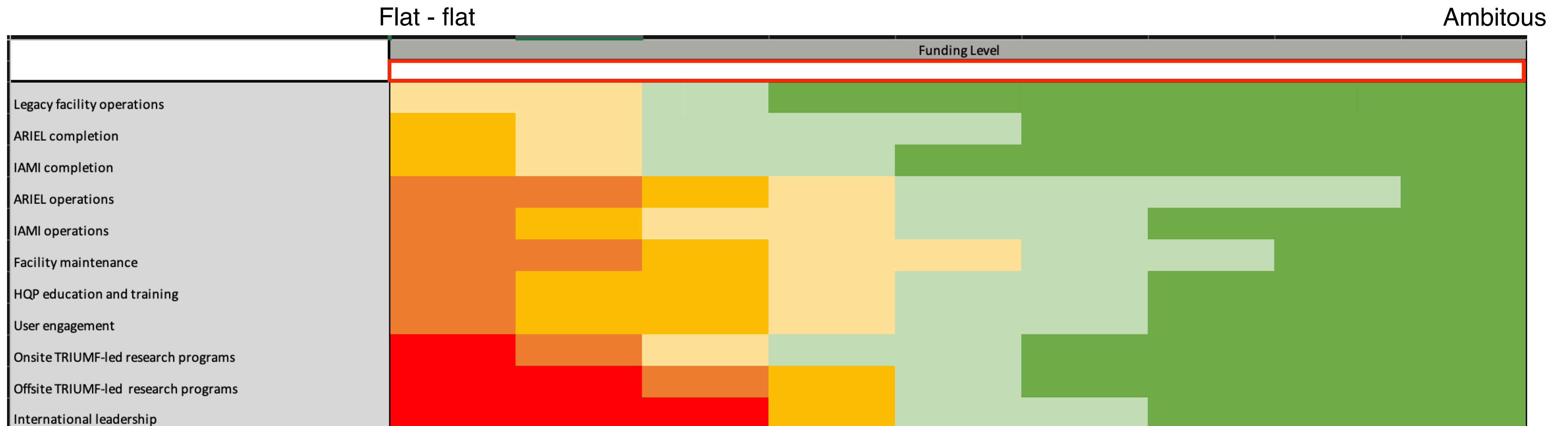

# Particle Physics planning and Centres



# Physical Sciences Division with Departments

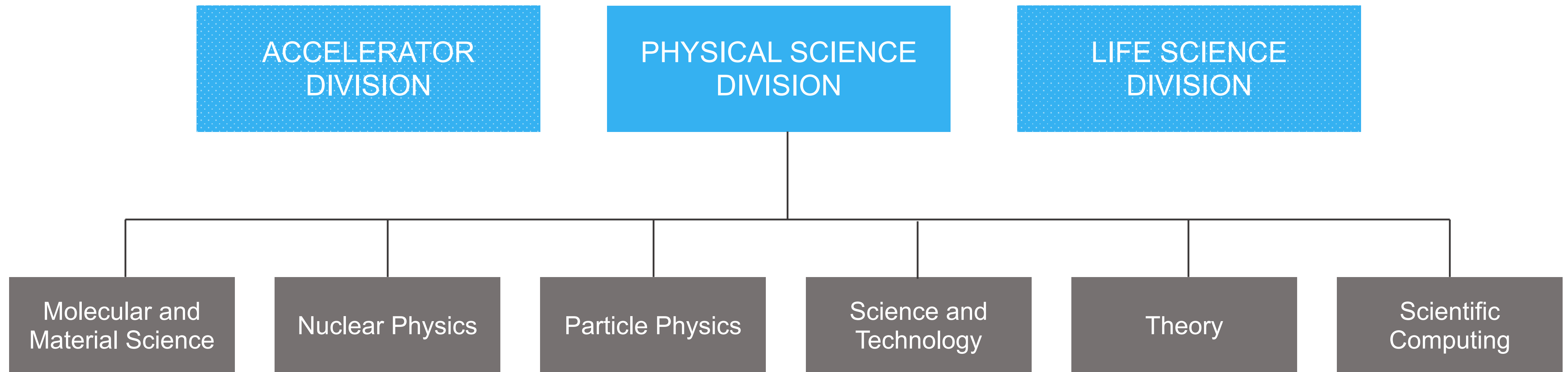

## 5YP - Physical Sciences Divisional Planning

- Alignment with TRIUMF 20-Year Vision
- TRIUMF Goals & Objectives
- Bottom-up approach – start at departmental level
  
- Scientist retreat on June 13, 2022
  - Consider current effort & “blue-sky” scenario
  - Discussions with the Leadership Team
  
- Engagement with broader community
  - Science Week, July 18-22, 2022
  
- Scientist retreat on June 2, 2023
  
- Engagement with broader community
  - Science Week, July 31 – August 4, 2023

## TRIUMF Five-Year Plan Goals

**Make ground-breaking discoveries across TRIUMF’s multidisciplinary research portfolio**

**Become a hub for interdisciplinary education and training**

**Inspire Canadians to discover and innovate**

**Increase national and international collaboration**

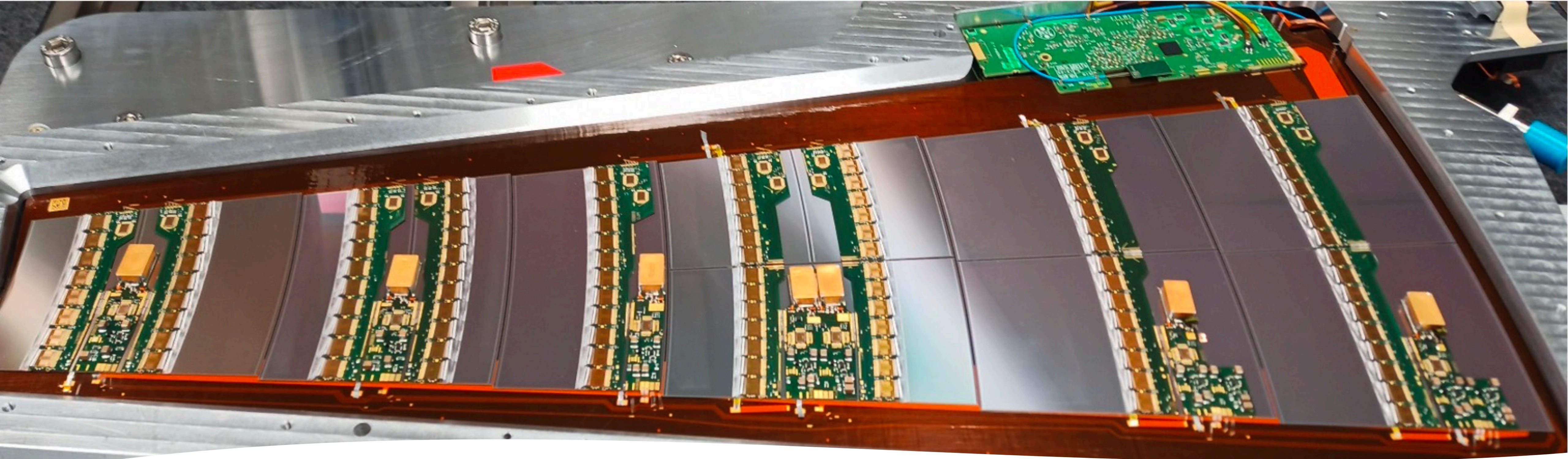

## Detector Center

- R&D focus for state-of-the-art detectors that leads to new capabilities and spin-offs
  - The first TPC in an experiment (TRIUMF E104)
  - The first SiPM in an experiment (T2K FGD)
- Facilitate detector development used and available across the laboratory and Canada
- Provide key expertise not available through e.g. CFI hires
- Sustainability Spin-Offs - air and water quality monitoring

## The Road Ahead



- Leverage on existing infrastructure ATLAS ITK, nEXO
  - Radiation hard silicon detectors for future colliders (CMOS, LGAD)
  - Collaboration with ECFA Detector Development Roadmap DRD2, DRD3
  - Digital Single Photon detection (SiPM)
- TRIUMF has an excellent track record on graduate student training and has a first class undergraduate & coop program
- Building on GRIDS, opportunity for a CREATE program
  - On-the-job training in cutting-edge research environment
  - Work integrated learning, in collaboration with e.g. BCIT
- Other technologies being looked at
  - Liquid noble detectors
  - Optical fibres for dosimetry

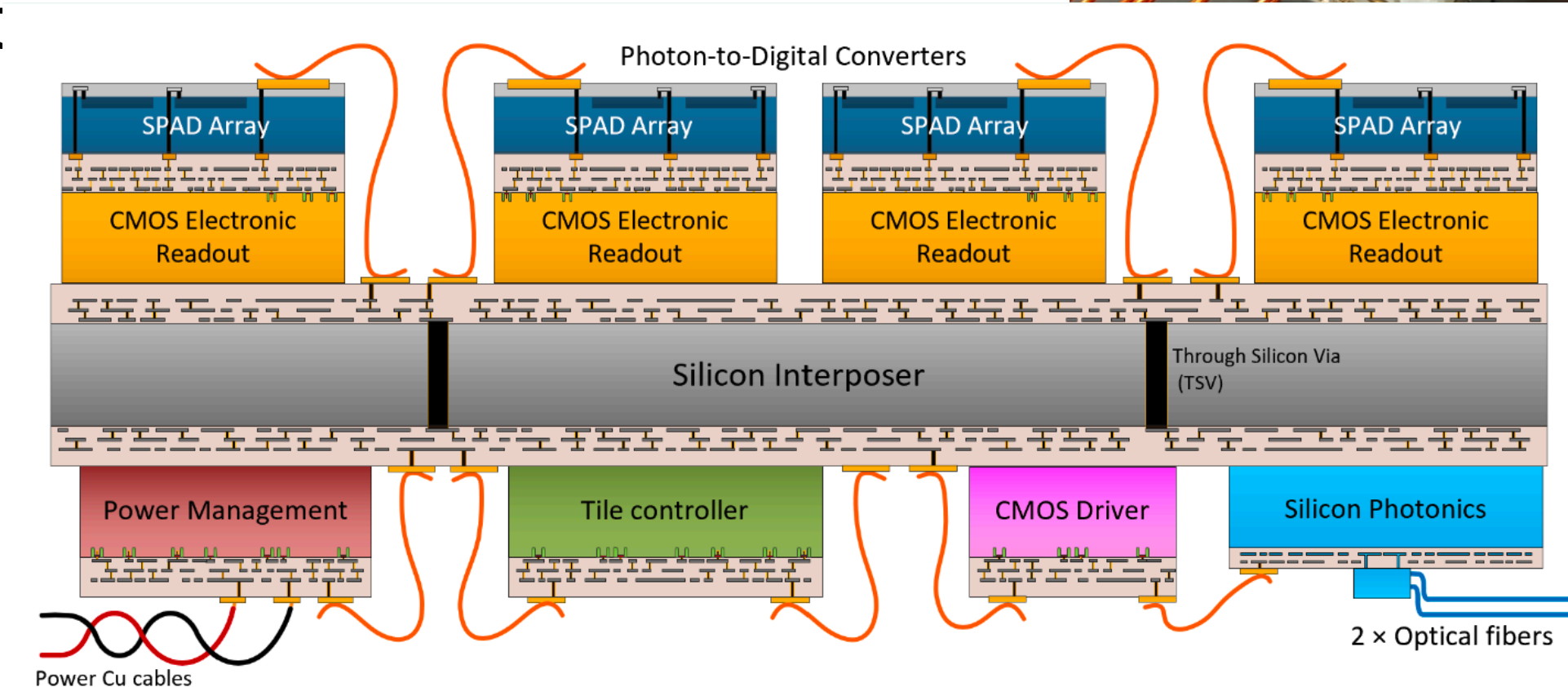
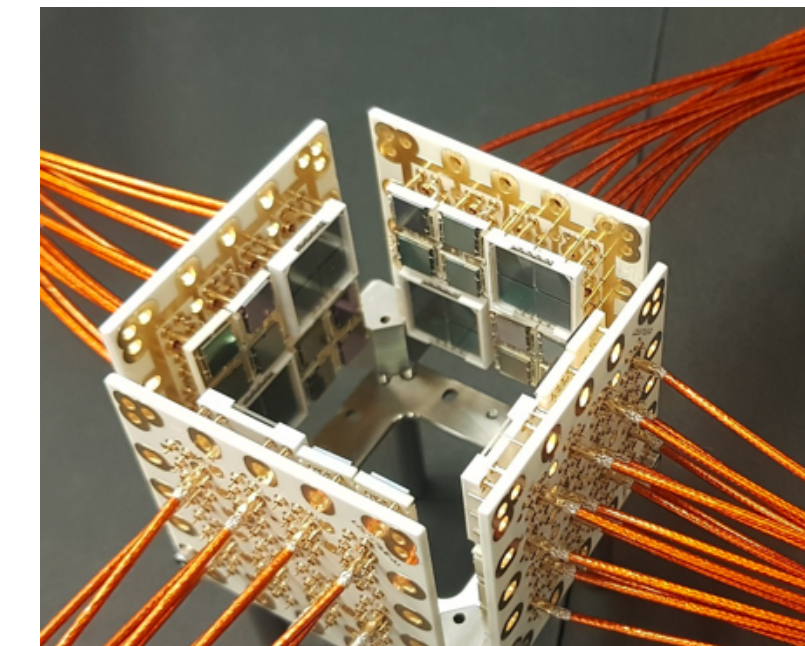

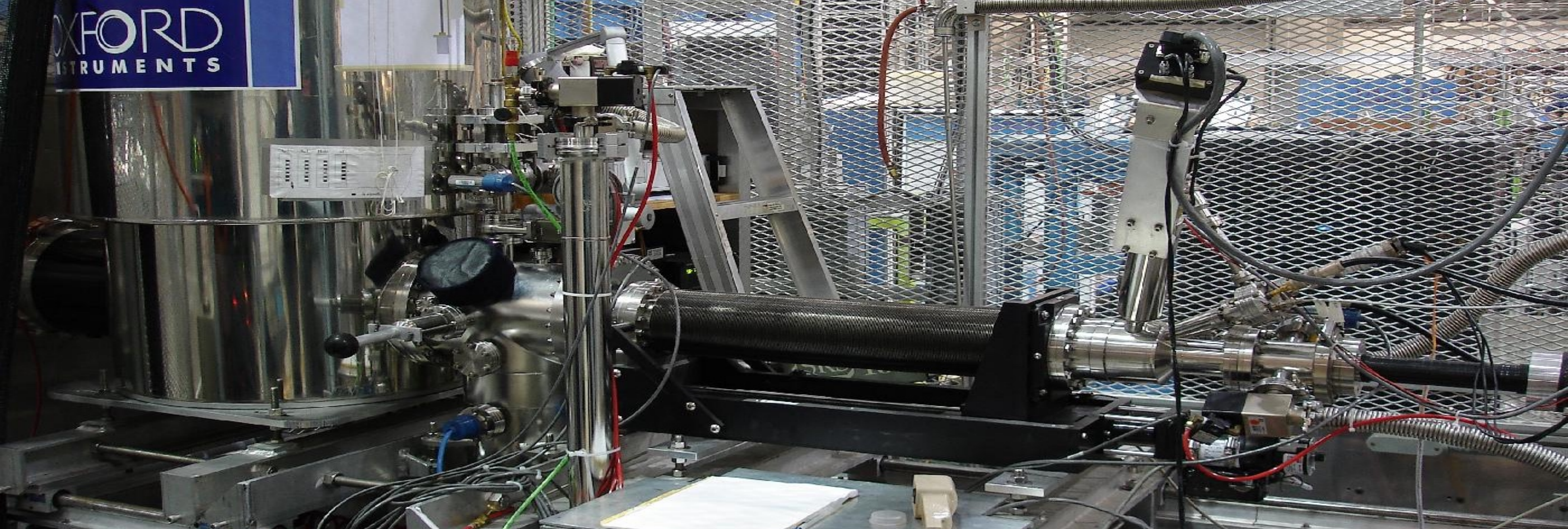

## Quantum Center

- Enhance the leading edge in TRIUMF's existing experimental programs which employs quantum techniques (spin polarized beams  $\mu$ SR and  $\beta$ NMR, TUCAN, ALPHA, Francium trapping, RILIS, etc)
- Connect Canadian researchers in novel use of quantum experiments
- Establish & support new flagship experiments at TRIUMF
  - RadMol, HAICU, etc
- Characterization laboratory to enable material characterization for green technologies (batteries and hydrogen storage devices)

## Quantum Center

- Existing quantum experiments spans across the laboratory divisions and departments
- They very often require common technical support & infrastructure
  - Cryogenics handling and design, laser metrology, coating expertise, magnet design
- Pool the resources and sustain the expertise in the long term and allow better cross-fertilization across departments and divisions
- Provides a structure that allows R&D stage critical to the development of new ideas prior to funding requests
- Act as a wedge for longer-term growth in quantum technologies – in alignment with 20 Year Vision



## Connecting to the Community

- Quantum Forum at TRIUMF with regular talks
- Joint session during Science Week in Vancouver and ICAP in Toronto



- Covered TRIUMF's existing and proposed involvements in Precision/AMO/Quantum measurements
- Infrastructure as a national lab enables experiments of scale beyond that of a single university
  - Gerald Gwinner (Manitoba): Atomic Parity Violation in Francium Atoms
  - Ronald Garcia Ruiz (MIT): Radioactive Molecules
  - Taka Momose (UBC): Antihydrogen & Hydrogen Fountains with ALPHA/HAICU
- Allow for input from the Canadian and International AMO community

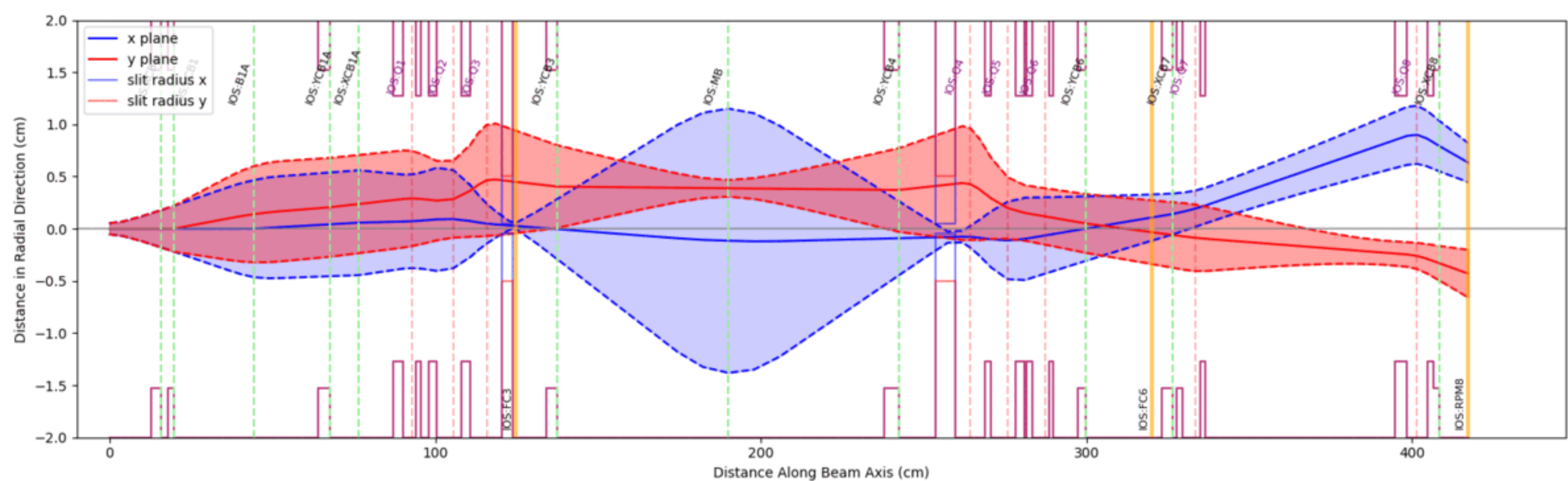

## Data Science Center

- Collaboration across departments and divisions
- Enhance Research Output
- Drives collaboration national and international
  - Helmholtz, WatchMal Collaboration
- Maintain and expand expertise in Quantum Computing and Quantum-assisted AI
- Infrastructure support



## The Road Ahead

- Machine Learning engagement fairly recent since 2018
  - Part of the current TRIUMF strategic plan
  - Particle physics applications → Science
  - Bleeding edge
    - Quantum Assisted ML
    - Trigger on FPGA
- Accelerator: AI-based beam tuning → better operations
- No active projects in: Nuclear physics, Molecular and Material and Life Sciences - Manpower limited!
- Vehicle for taking advantage of National Quantum Strategy
  - Research (Alliance Quantum / International / Consortia)
  - Talent (CREATE / MITACS)
  - Commercialization Pillar (incl NRC AQC)

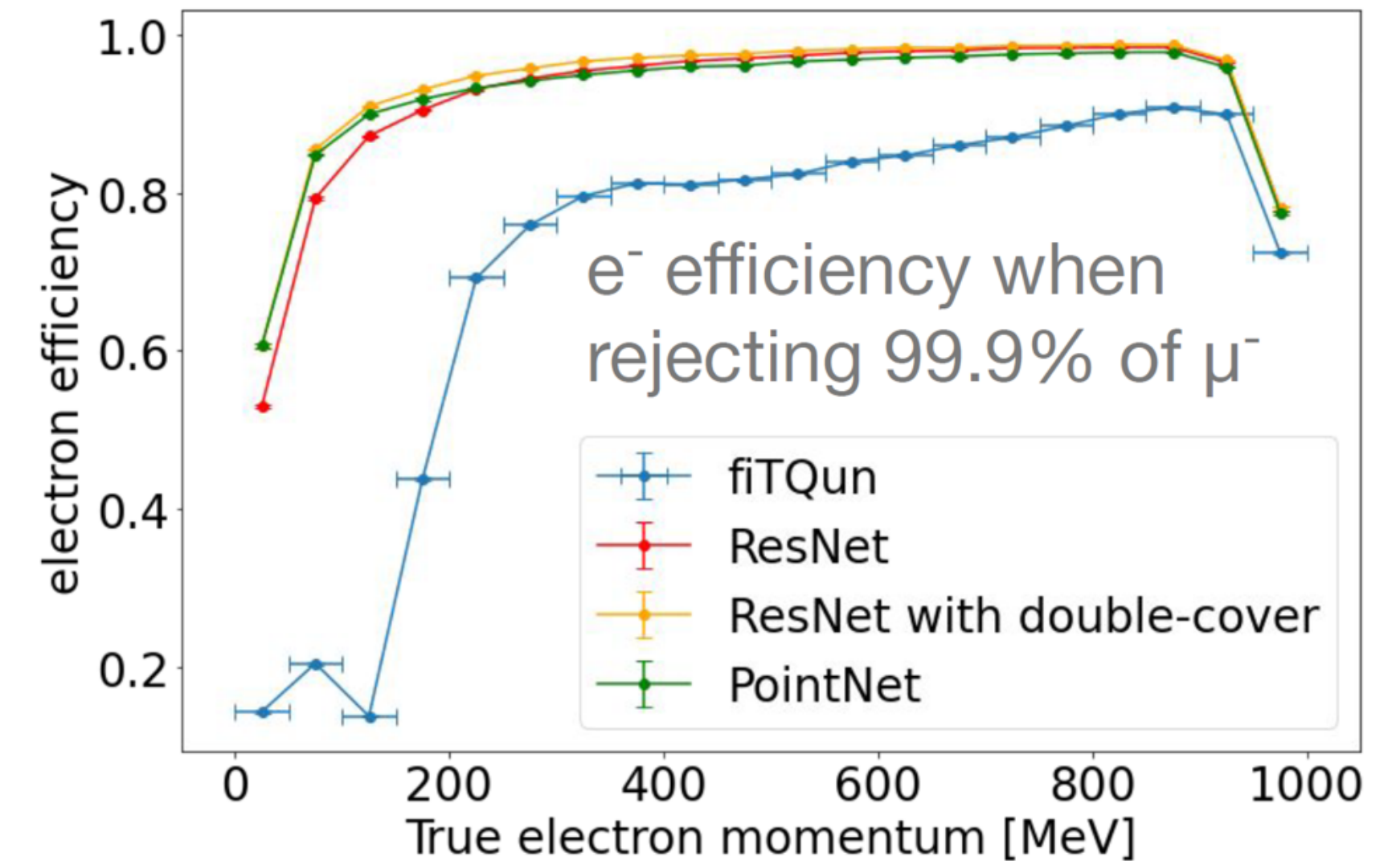

## Centers at TRIUMF

- Proposed centers for
  - Detector Development
  - Quantum Technologies
  - Data Science
- Strengthen core competencies with KEY expertise that enables new capabilities and technologies and training
  - Spans across divisions and departments
  - Sustain long term expertise
  - Allows critical R&D stage to support new ideas enabling future breakthroughs
- Connect to, support, and enhance community resources
- Maximise TRIUMF resources to support community initiatives

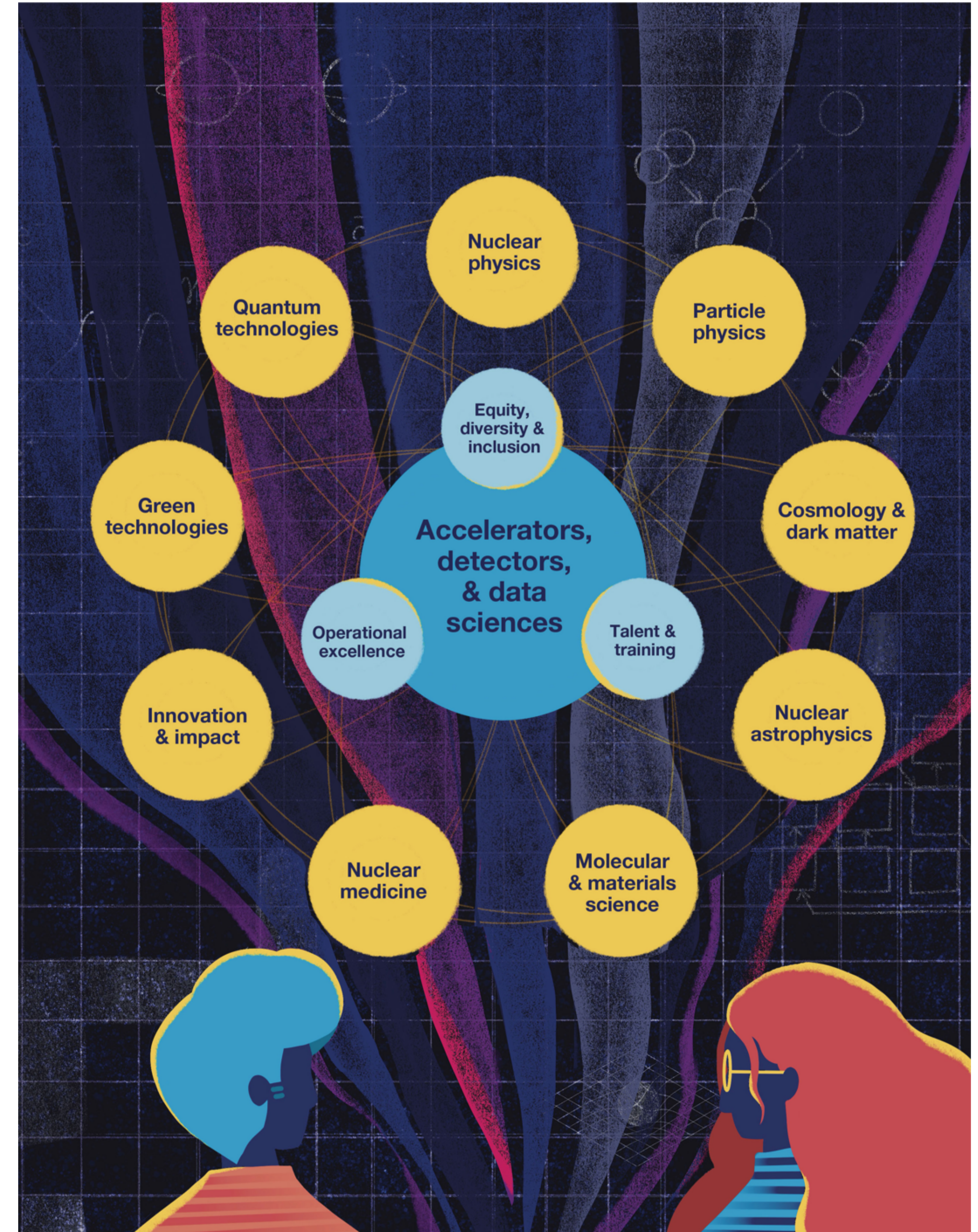



# Questions...

[www.triumf.ca](http://www.triumf.ca)

@TRIUMFLab

