

# SRF Development in Canada

Bob Laxdal  
TRIUMF

2022-06-05



# RF Acceleration

- RF accelerators utilize 'rf cavities' or 'resonators' to contain EM fields
- The cavity is sized to resonate at a particular rf frequency
- The cavity shape is designed to produce strong electric fields along the path of the charged particle
- The rf magnetic field induces surface currents on the walls of the conductor that are responsible for Ohmic power losses

$$\frac{dP_c}{ds} = \frac{1}{2} R_s |H|^2$$

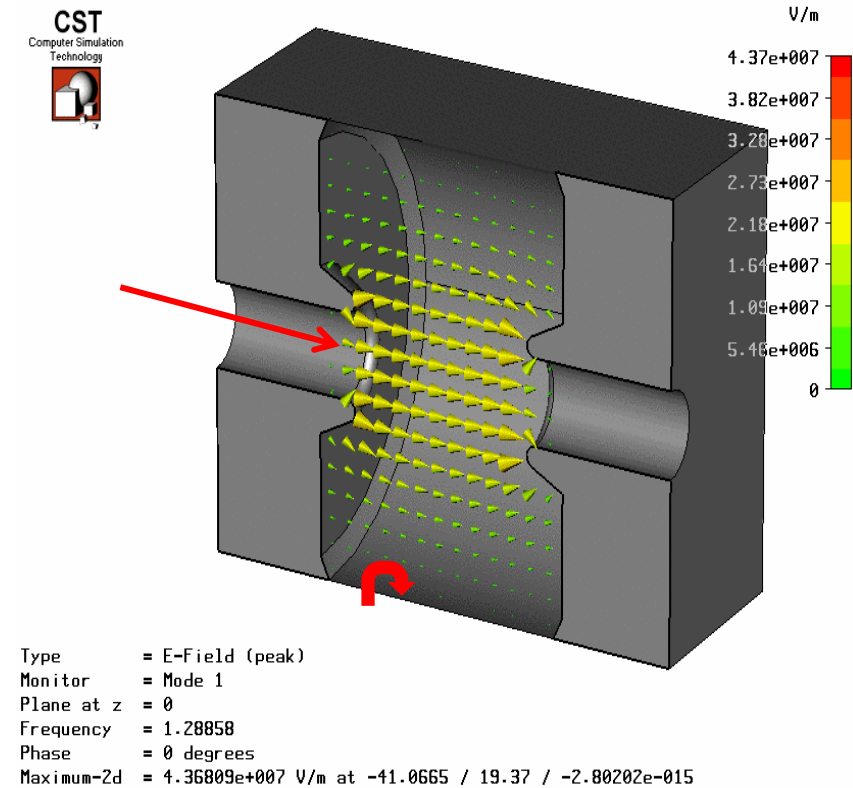

$$F = qE(t) = qE_0 \cos(\omega t)$$

# Superconducting Technology

- Ohmic losses can be greatly reduced by using superconducting technology
- Cavities are typically made from Niobium ( $T_c=9.2\text{k}$ )
- SRF resistance is small but finite
  - SC Niobium has a rf surface resistance ~five orders of magnitude lower than room temperature Niobium
- Cavity performance is characterized by the quality factor  $Q$  and the accelerating gradient  $E_a$

$$Q \propto \frac{1}{R_s} \quad P_c \propto \frac{(E_a L)^2}{Q_0}$$

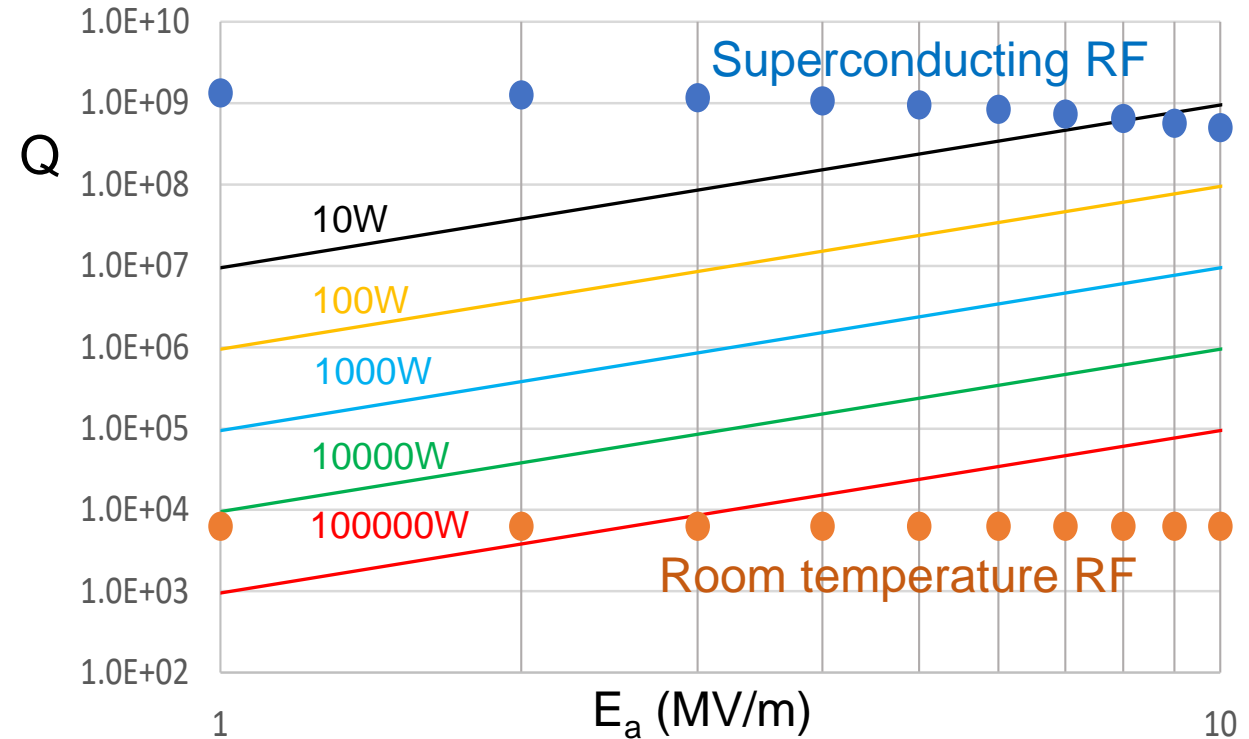

**After accounting for Carnot efficiency SRF technology is ~100 times more efficient than normal RF**

# SRF Accelerators in Canada



# Canadian Light Source



Canadian  
Light  
Source

Centre canadien  
de rayonnement  
synchrotron

First light source to use SRF technology from the beginning of operation in 2003

Utilize a 500MHz CESR-B cavity developed at Cornell University and built at Research Instrument, Germany





# Canadian Light Source



Canadian  
Light  
Source

Centre canadien  
de rayonnement  
synchrotron

- SRF cavity compensates beam energy lost to synchrotron radiation
- CLS has an on-going project to add a second cavity to the ring for redundancy and improved performance

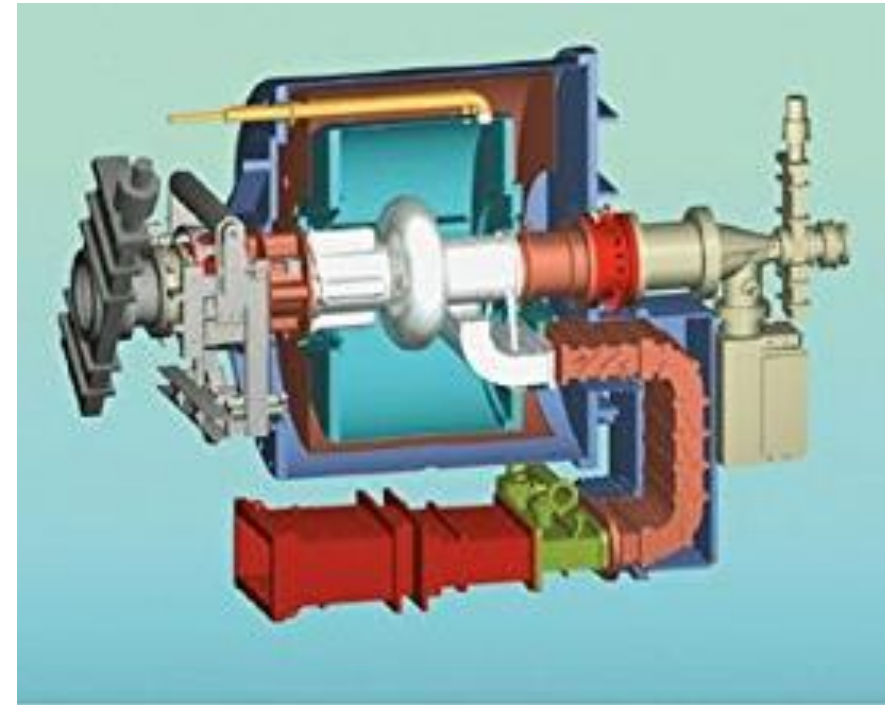
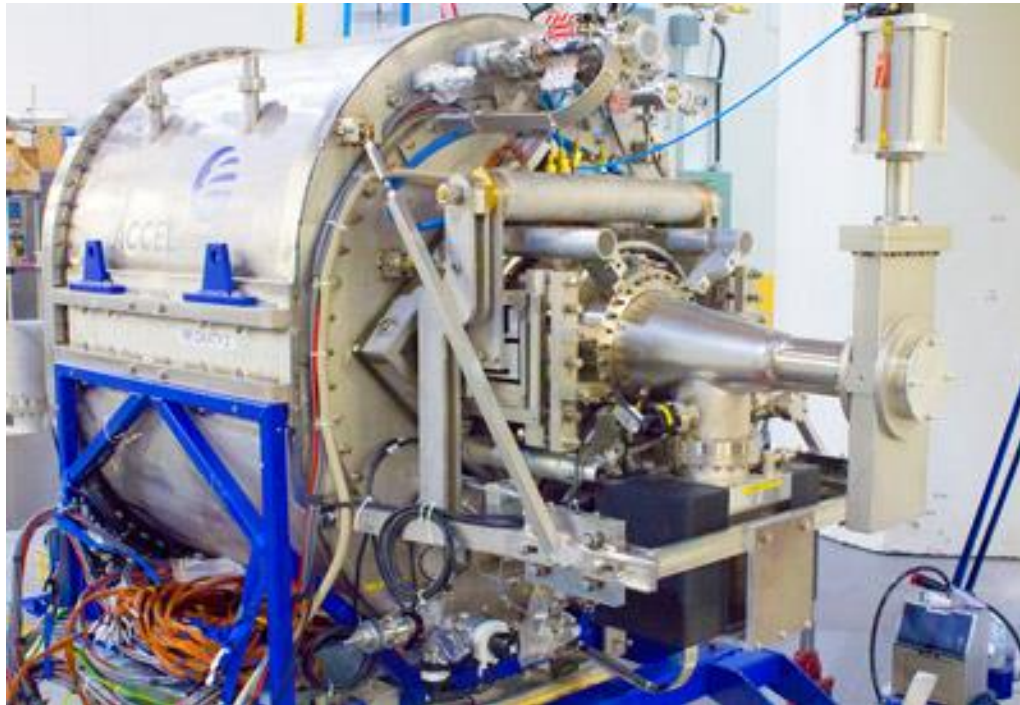

# SRF at TRIUMF

- The TRIUMF SRF program began in 2000 to support the design and development of the ISAC-II heavy ion linac
- We now have two SC linacs in operation
  - The 40MV ISAC-II heavy ion linac
  - The 30MV ARIEL 1.3GHz electron linac
- TRIUMF also hosts important diagnostics in material science –  $\mu$ SR and  $\beta$ NMR
- We have an active program in student based SRF research to augment are operational capabilities
  - Strong collaboration with U. Victoria (Tobi Junginger)

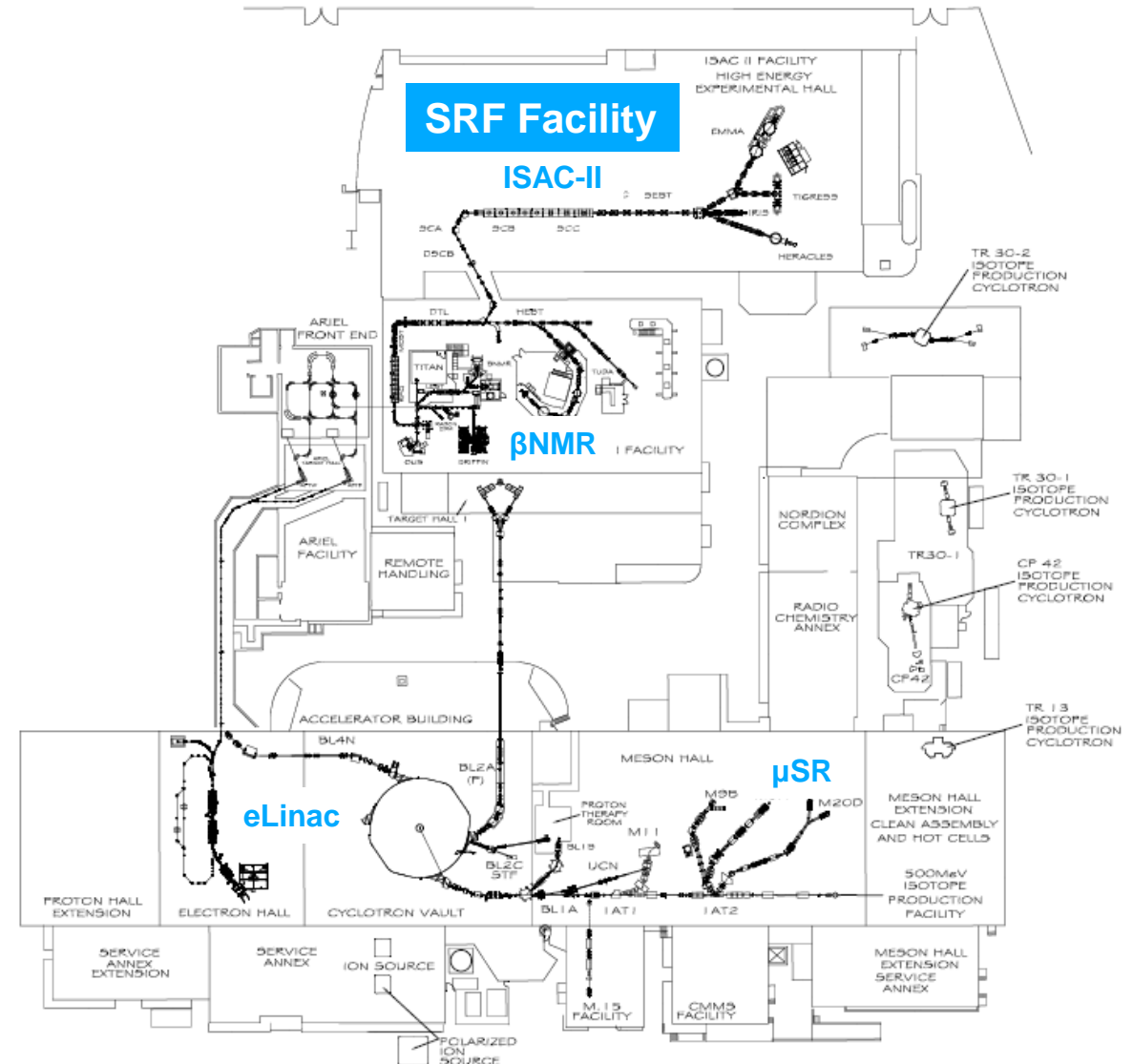



# SRF Accelerators at TRIUMF

**40MV ISAC-II SRF  
heavy ion linac  
@ 106 and 141 MHz  
in operation since  
2006**



**30MV ARIEL SRF  
10mA electron linac  
@ 1.3 GHz  
first beam 2014**





# TRIUMF SRF Facilities

- The legacy from the development of the TRIUMF superconducting linacs is an SRF facility and know-how, unique in Canada,
- The lab supports the in-house accelerator program, external collaborations as well as SRF research and, through NSERC funds, a varied student program in close partnership with U.Victoria

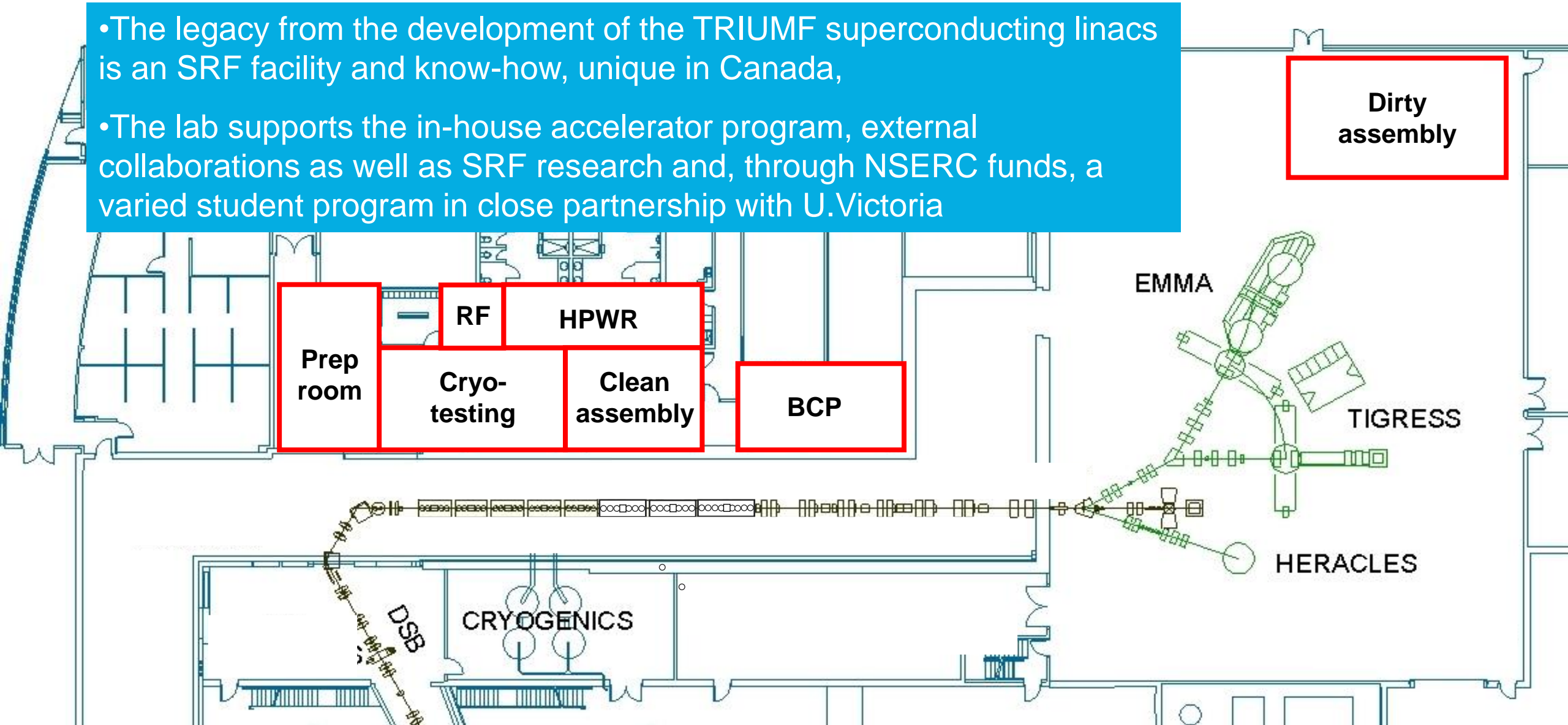

# TRIUMF SRF Facilities



**Dirty assembly**

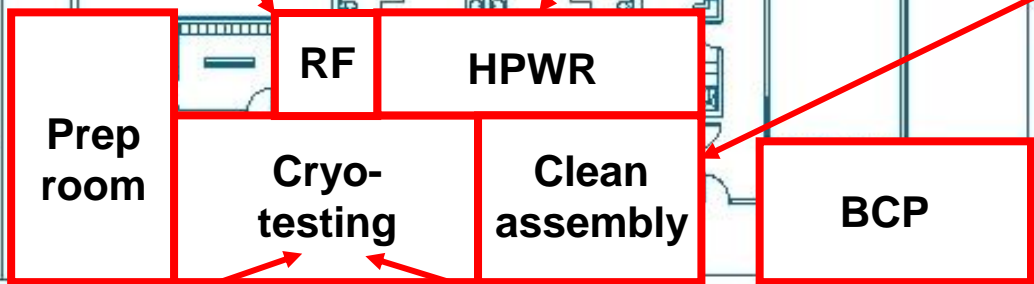

EMMA

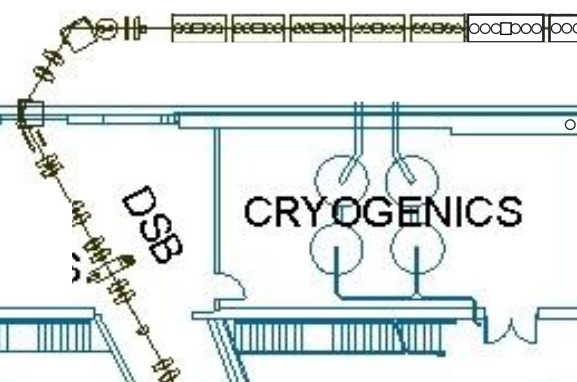

HERACLES

# TRIUMF and International Collaborations



# TRIUMF External Collaborations

- TRIUMF was contracted to prototype a Single spoke resonator at 350MHz for RISP (S. Korea)
  - TRIUMF developed and successfully tested a new variant, the balloon geometry, that was adopted by the project
- TRIUMF has been collaborating with VECC in Kolkata for several years
  - 2018 – TRIUMF fabricated, tested and shipped a 1.3GHz cryomodule
  - 2022 – TRIUMF has fabricated and successfully cold tested a heavy ion cryomodule to be shipped this year

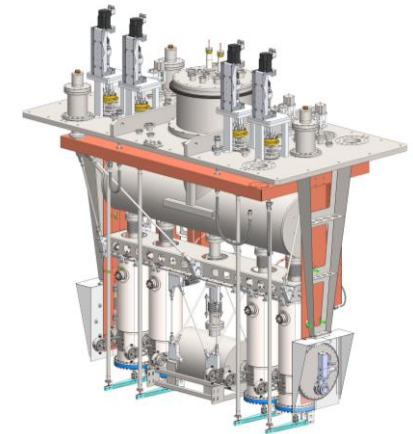
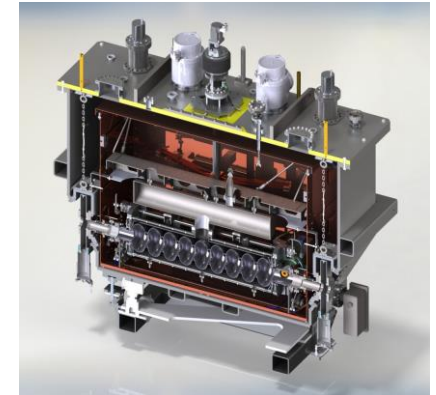
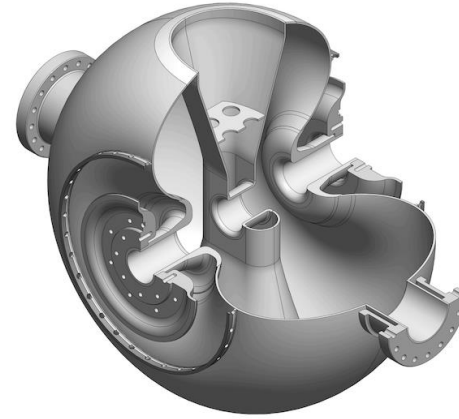

## HL-LHC Crab Cavity Cryomodules

TRIUMF will receive 10 RF Dipole crab cavities produced and qualified by a US DOE lab consortium (AUP) and will assemble each pair of RFDs into five cryomodules

A prototype will be assembled in 2022-23 and series production at TRIUMF will span 2023-25

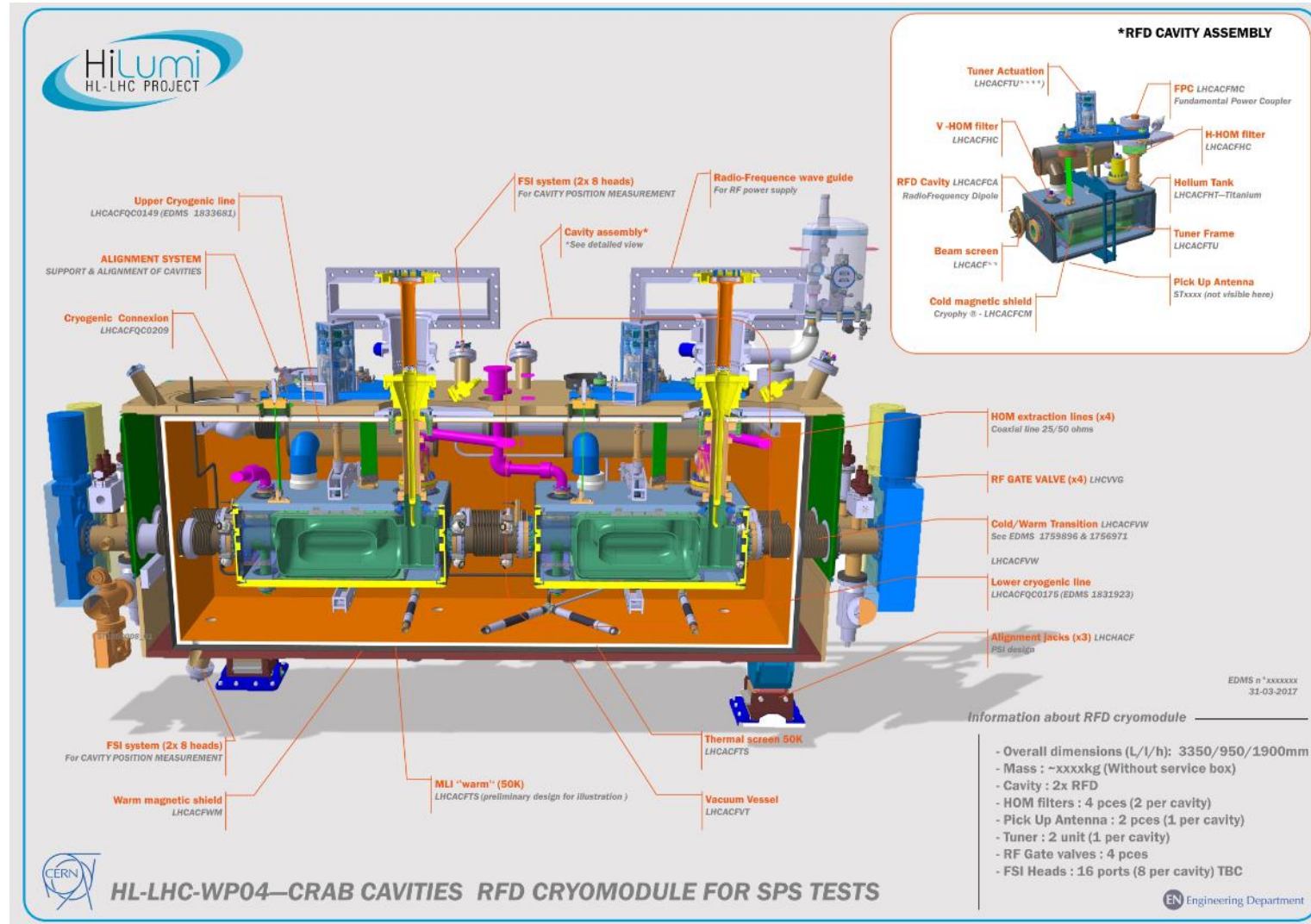

# SRF Fundamental Development



# Optimization Strategy (High Q, High Gradient)

- For high gradient we need a material that can withstand magnetic vortex penetration up to a high rf magnetic field
- For high Q we need to optimize the mean free path in the near surface – create 'dirty' overlayer

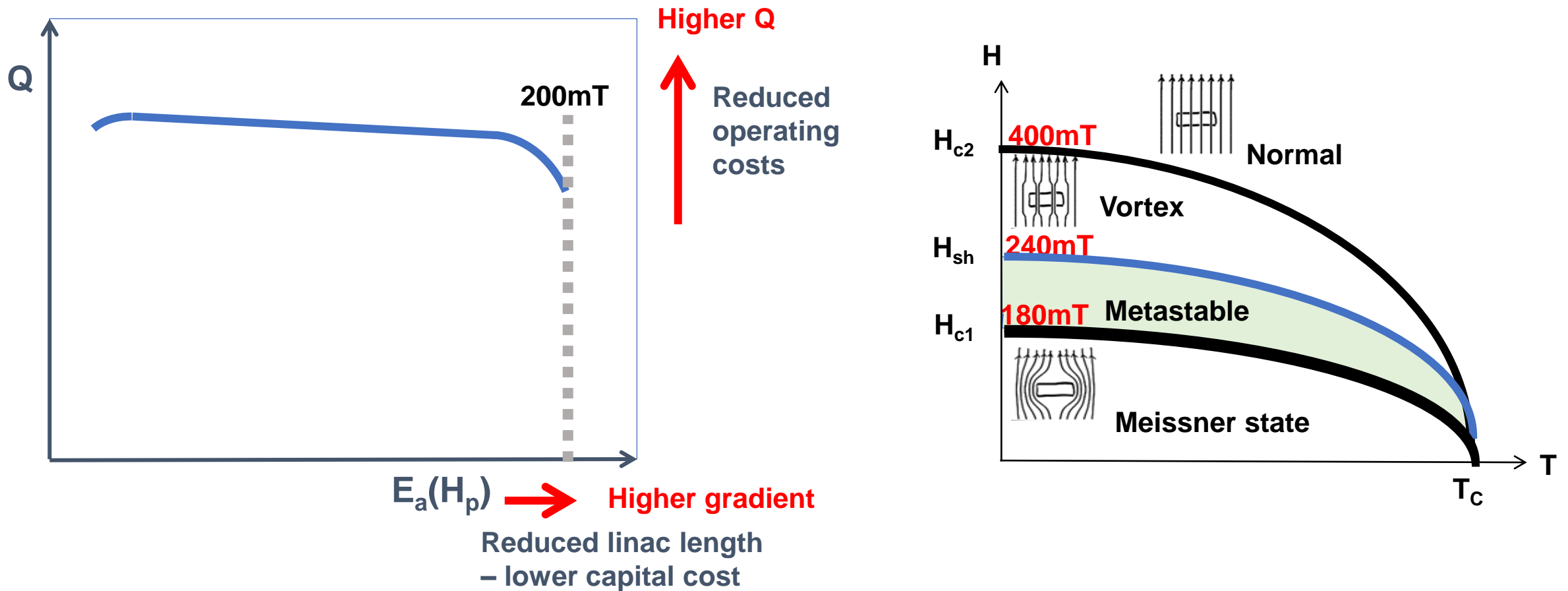

# Status of SRF High Q, High Gradient

- Customized heat treatments are being used to modify the rf surface in vacuum (O-diffusion) or low-pressure gas atmosphere (N-diffusion)
- **These studies have been typically done at 1.3GHz**

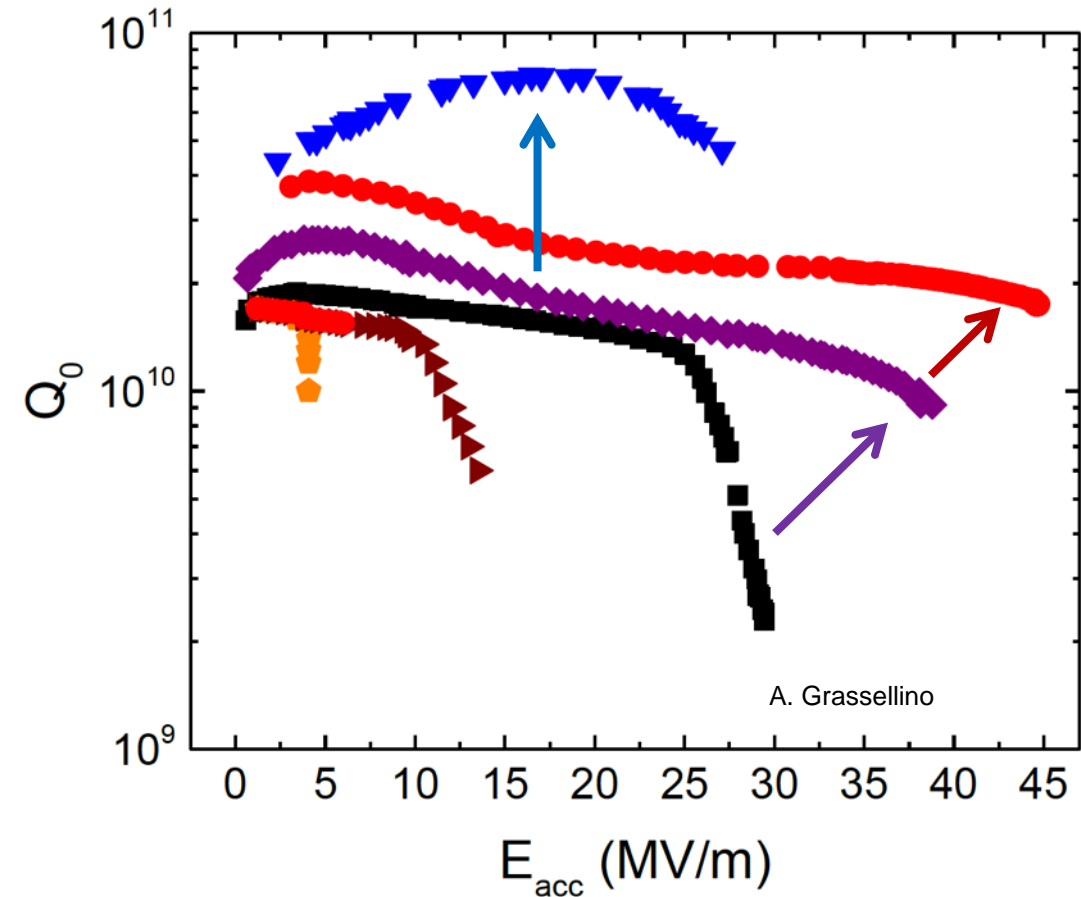
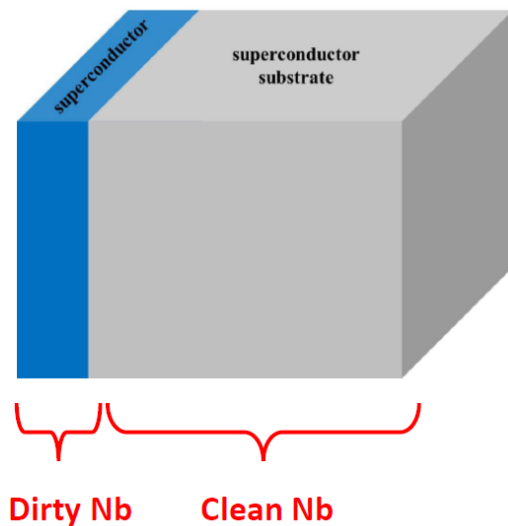

- 120°C bake – reduces high field Q-slope
- N doping at 800C
- N infusion at 120C
- Mid-T bake (300-400C) in vacuum – similar to N-doping (not plotted)

# SRF cavities – velocity and frequency range

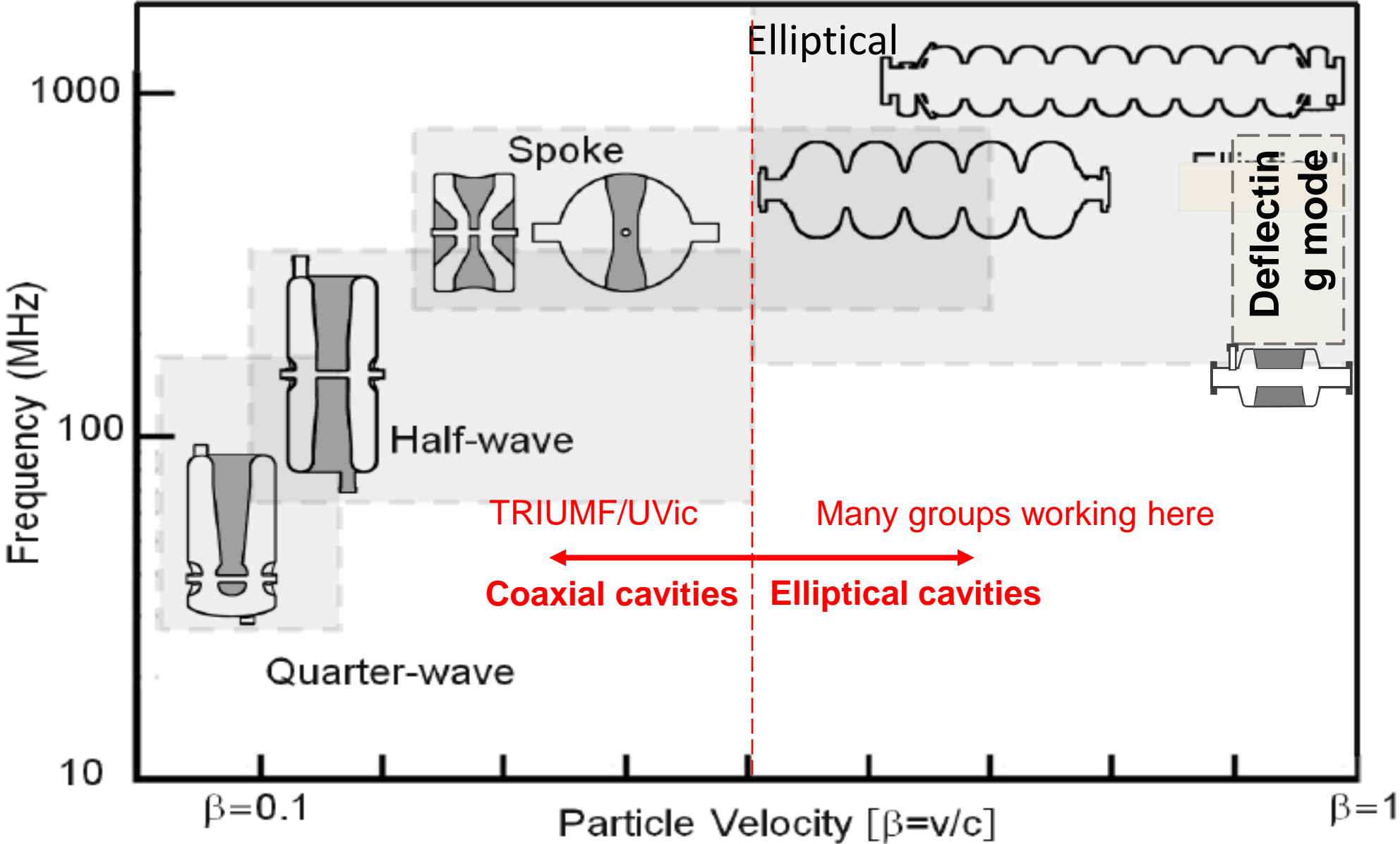



# SRF Development at TRIUMF/U.Victoria

Two broad themes:

- Coaxial cavity research and development
- Material science in support of high Q and high Gradient

# Coaxial cavities (NSERC RTI grant)

- TRIUMF has designed and built two research cavities – QWR and HWR
- Cavities allow excitation of different resonant modes  $\rightarrow$  rf frequency dependence to cavity performance.
- Research explorations:
  - Can surface treatment gains at high frequency in elliptical cavities translate to lower frequency coaxial cavities
  - How does the field dependence of the rf surface resistance depend on frequency
  - How to mitigate flux trapping in coaxial cavities

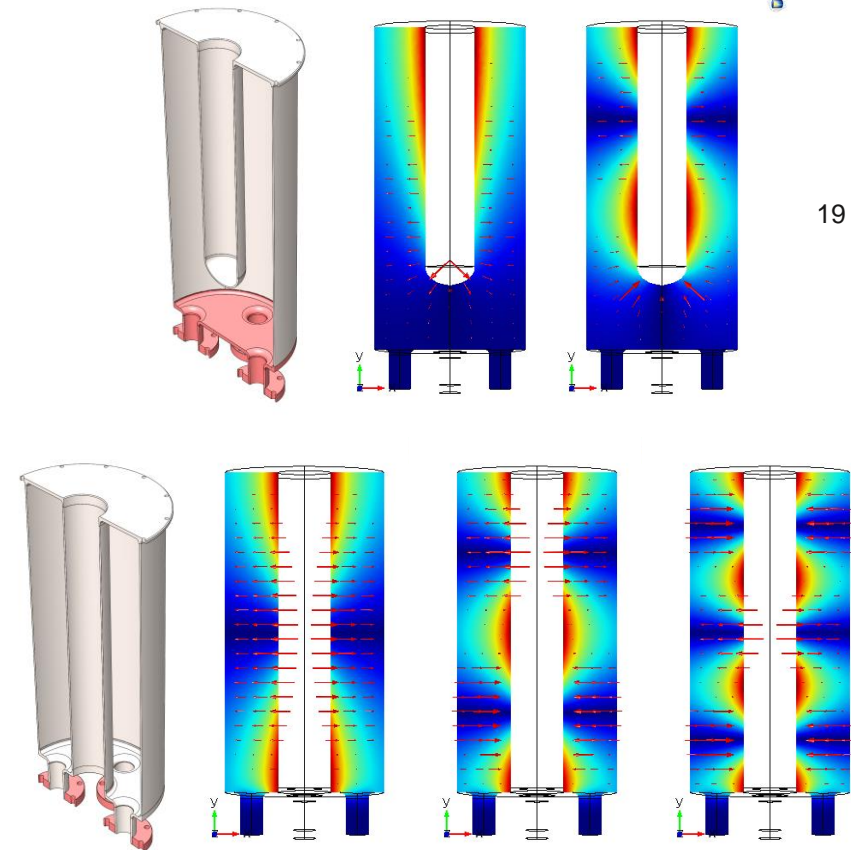

19

P. Kolb et al: [Phys. Rev. Accel. Beams 23, 122001](https://doi.org/10.1103/PhysRevAccelBeams.23.122001)

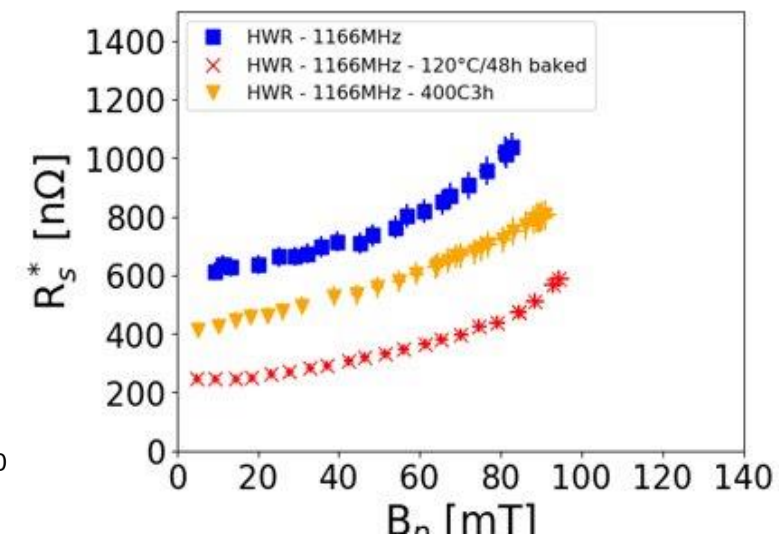
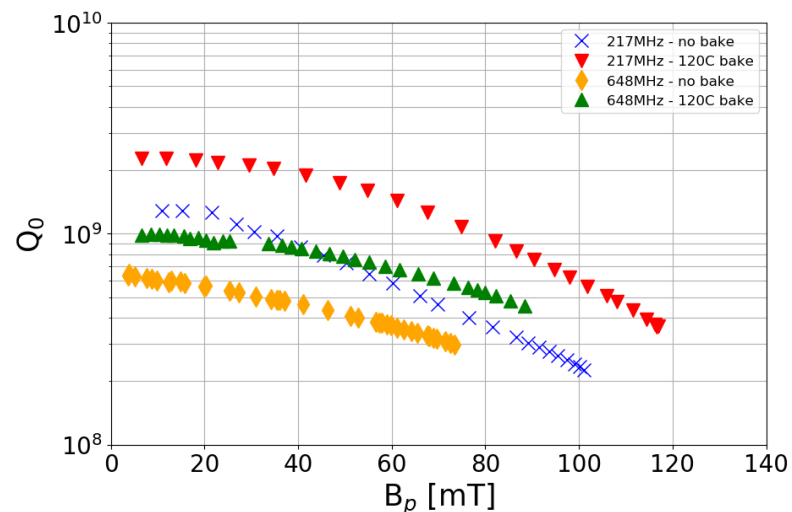

# Infrastructure to support coaxial program

- Induction furnace for customized heat treatments in coaxial cavities – [PDF Philipp Kolb \(TRIUMF\)](#)
- T-map diagnostic for coaxial cavities – NSERC RTI
  - World's first T-map for TEM mode cavities – PCB boards and sensors in hand – assembly and test this summer - [Coop student project](#)
- Electro-polish treatment facility for coaxial cavities (NSERC RTI)
  - World's first comparison of BCP vs EP treatments in coaxial cavities – [Coop student project](#)
- The thermal interface and trapped flux studies applied to TEM mode cavities
  - [Mattias McMullin \(MSc UVic\)](#), [Ruth Ann Gregory \(MSc, UVic\)](#)



Induction furnace

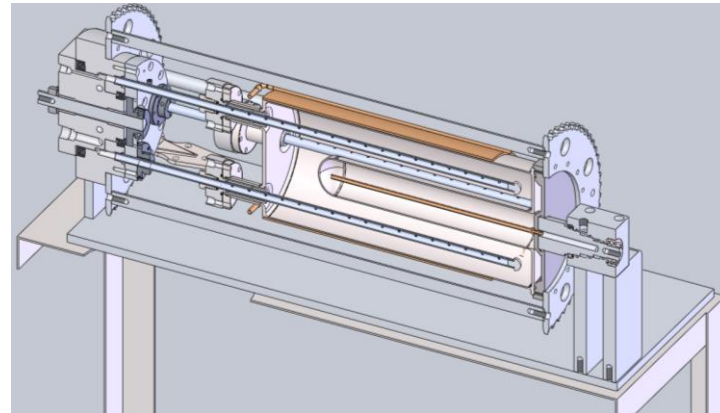

Electro-polish tool

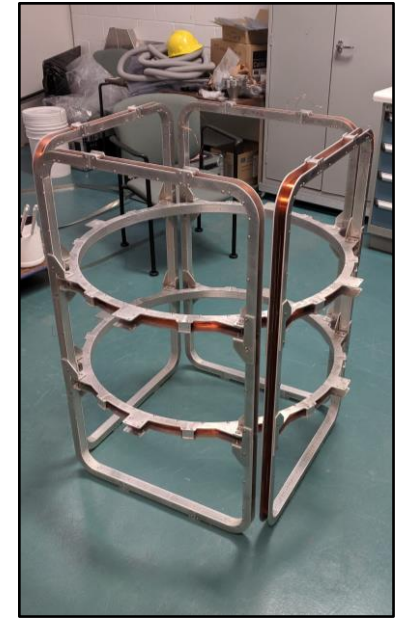

Helmholtz coil

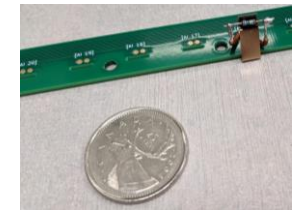
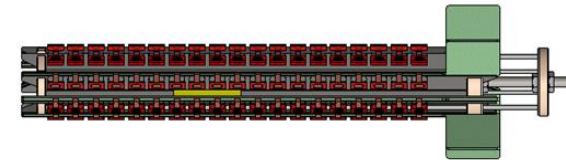

T-map diagnostic



# Sample characterization after heat treatment

## Several new baking procedures tried for the first time on coaxial cavities

- Baking requires very clean environments to avoid undesired pollution
- We use a wide variety of methods including
  - SEM/EDX, TEM (UVic), SIMS (University of Waterloo)
  - muSR (TRIUMF, PSI), betaNMR (TRIUMF)
  - Neutron tomography (HZB)
  - Vibrating sample magnetometry (ISIS, UK; to be developed at UVic)

SEM: scanning electron microscopy,  
EDX: energy dispersive X-Ray spectroscopy,  
SIMS: Secondary ion mass spectroscopy



SEM image before and after furnace cleaning

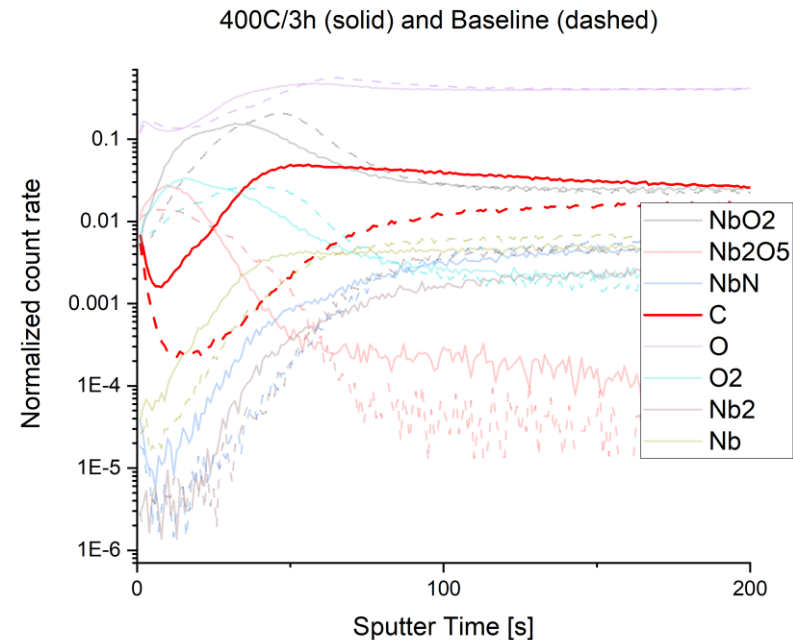

SIMS data showing C pollution (dashed) vs baseline (solid) during N-infusion

# Material Probes of magnetic response – $\mu$ SR & $\beta$ -NMR

- TRIUMF has two world class material science probes in  $\mu$ SR and  $\beta$ -NMR – utilize the beta-decay of a beam of polarized muons or  $^8\text{Li}$  ions respectively as probes of local magnetism
- TRIUMF  $\mu$ SR samples below surface fields (100 $\mu\text{m}$  depth) - Allow measurements of the on-set of flux penetration from an applied DC magnetic field
- LE- $\mu$ SR at PSI and beta-NMR at TRIUMF samples near-surface (0-200nm depth) and allows depth profiling but have both been limited to 25mT parallel fields.
- **TRIUMF has recently installed and commissioned a new spectrometer capable of applying a parallel field of 200mT (near  $H_{c1}$  for Niobium).**
- **The facility is unique in the world and will be instrumental to diagnose new treatments (doping), new materials and new layered structures**

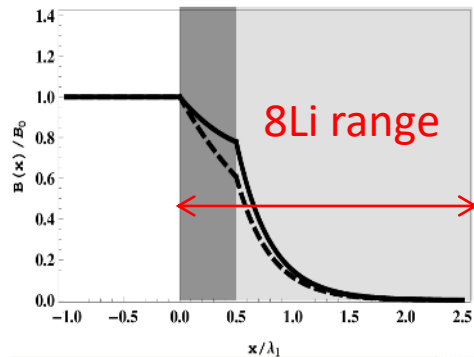
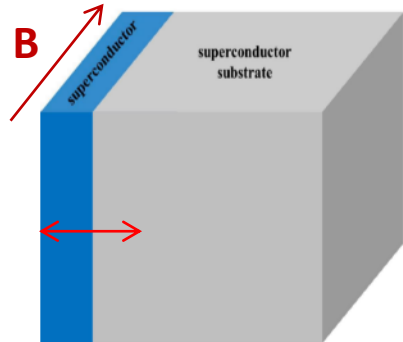
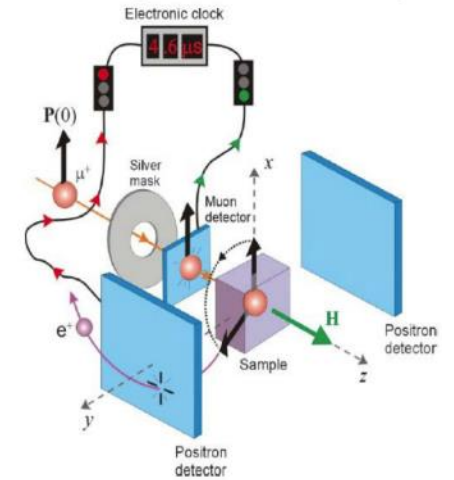

0-200 mT

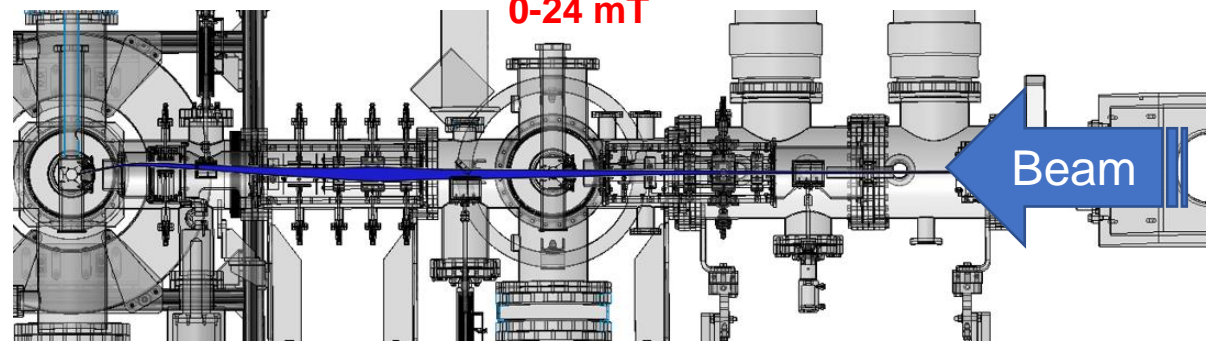

New beamline

Modified

# Beta-SRF Beamline – NSERC RTI

- Beta-SRF is ideal for SRF characterization of layered materials with the capability of sampling the local magnetic field through the London layer at applied fields relevant for high gradient SRF investigations – no other facility has this capability
- First tests completed at 50mT

23

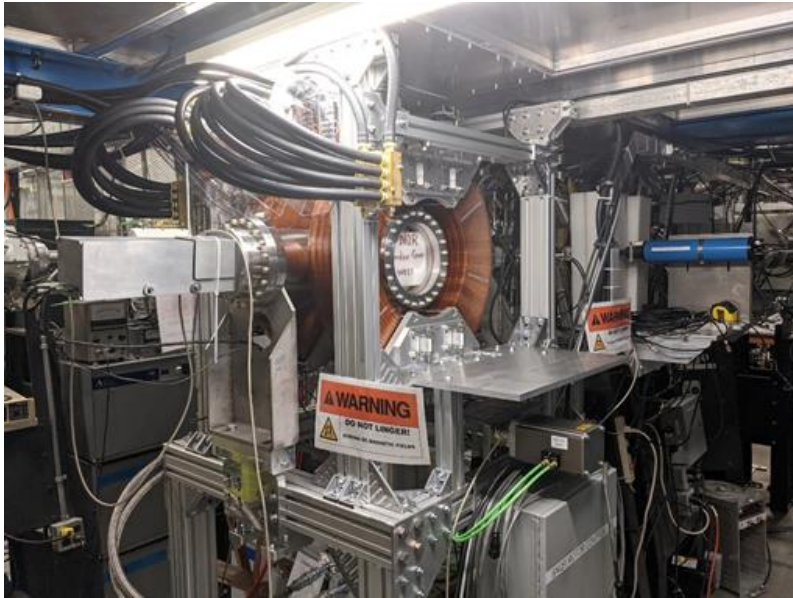

First experimental studies of SRF materials at beta-NQR at high parallel field (50mT) show clear difference in Meissner screening between N-diffused (left) and O-diffused (right) samples

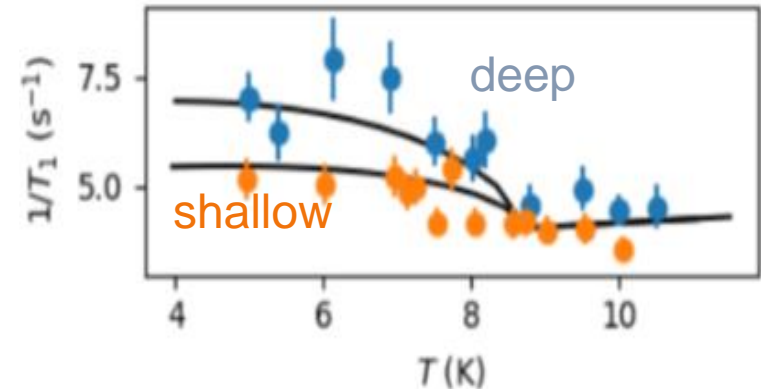
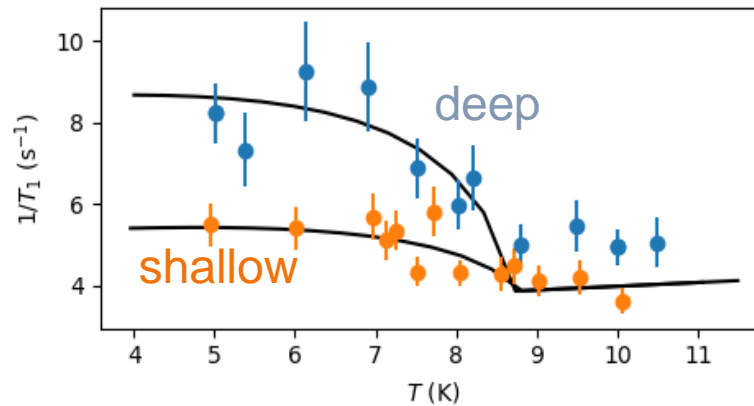

- PhD thesis of Edward Thoeng, UBC (NSERC)
- PhD thesis Asad Azaduzzaman, UVic (NSERC)
- PDF research - Ryan McFaddin, UVic

See Edward Thoeng – Session R2-3 – Thursday - Beta-SRF at TRIUMF - A Unique Facility to Characterize SRF Materials Near Fundamental Limits

# ISAC-II energy upgrade

- ISAC-II is presently delivering 38 MV
- A proposed upgrade of the SRF cavity processing infrastructure will permit ISAC-II performance upgrade to  $\geq 45$  MV
- Afterburner cryomodule using state-of-the-art fabrication and processing would add 16 MV to result in  $>60$  MV total
- Would restore world lead in RIB post-accelerator performance back to ISAC-II

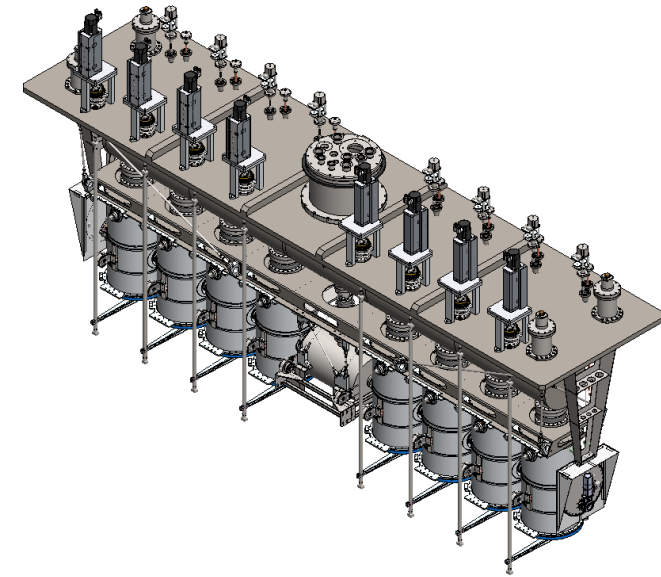
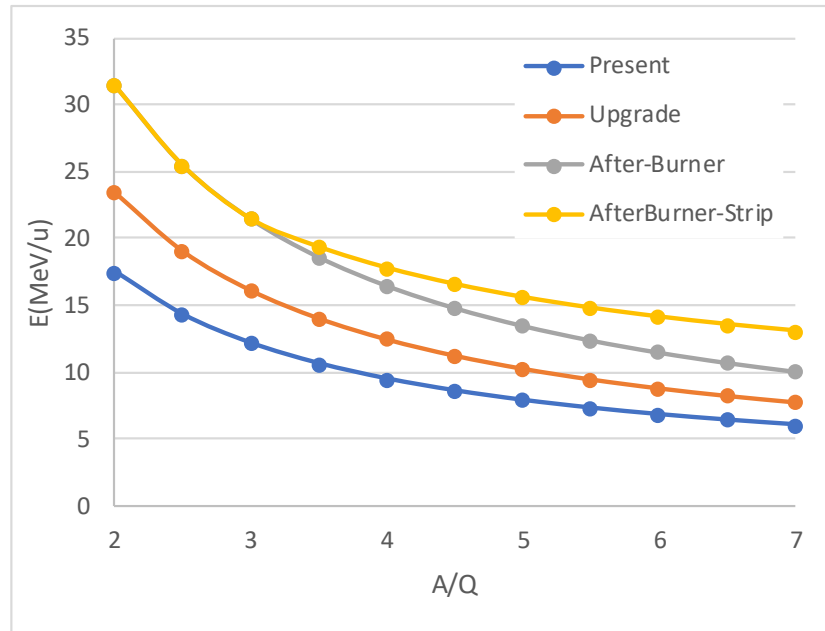
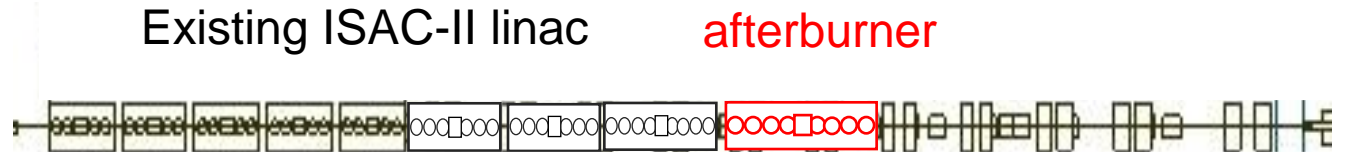

Coop student project



# Summary

- SRF technology is exploited at CLS and TRIUMF
- At TRIUMF SRF R&D supports the high performance and availability of TRIUMF accelerators to enable discovery science
- In addition SRF infrastructure and NSERC funds are leveraged to deliver cutting edge research
  - To educate and train highly skilled personnel
  - To collaborate with Canadian universities to advance SRF science and technology
- Other goals
  - Contribute to international projects with critical accelerator components and expertise
  - Transfer knowledge to Canadian industries to enhance their capabilities in the global competition

Thank you  
Merci

[www.triumf.ca](http://www.triumf.ca)

Follow us @TRIUMFLab



# Field of First Flux Entry with $\mu$ SR

- $\mu$ SR used to study the role of overlayers in screening surface magnetic fields
- Nb 1400°C annealed, MgB<sub>2</sub> (50-300nm) and Nb<sub>3</sub>Sn (1-3.5 $\mu$ m) on Nb
  - A layer of a higher  $T_c$  material on Nb can enhance the field of first entry by about 40% from a field consistent with  $H_{c1}$  to a field consistent with  $H_{sh}$
- This enhancement does not depend on material or thickness suggesting that superheating is indeed induced in niobium by the overlayer which is inconsistent with both models

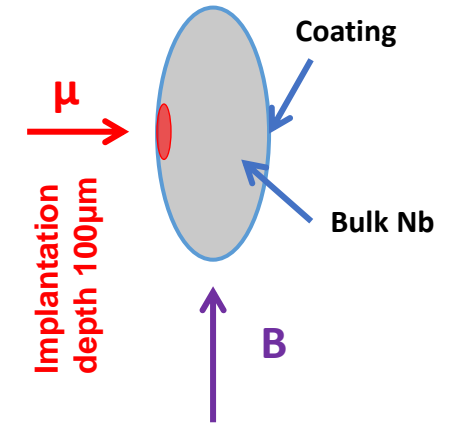

27

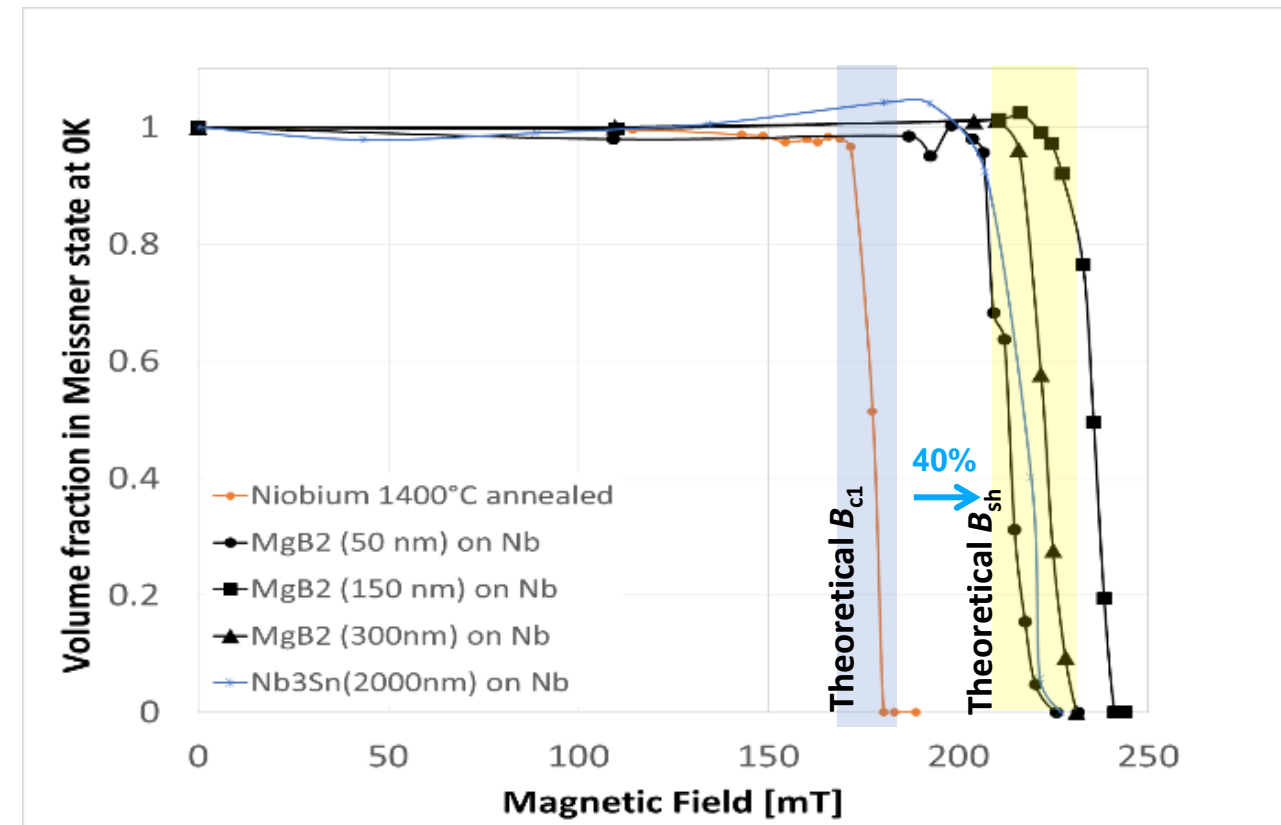

# RF Separator Cavity (UVic PhD student D. Storey)

- 650MHz RF deflecting mode cavity is designed to allow ARIEL e-Linac operating in recirculating mode
- Cavity is fabricated from reactor grade Niobium, machined from bulk and with TIG welding
- First SRF cavity fully fabricated at TRIUMF
- Cavity recently tested and meets design specification

