

Development of Next-Generation Argon Dark Matter Search: ARGO

Outline:

- The science of ARGO
- The ARGO-Canada and international GADMC collaborations
- Digital SiPMs (Photon-to-digital converters) and recent progress
- Summary of short-term activities

Mark Boulay for ARGO-Canada
CAP 2021 Virtual Congress PPD LRP session
mark.boulay@carleton.ca

Searching for dark matter particle interactions

DM: particle or not?

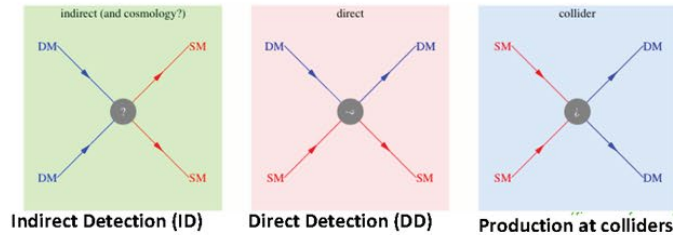

**prime suspect:
some new particle
outside the SM**

Alternatives:

- Primordial black holes
- Modified gravity
- ...

Scientific objectives of DD searches:

- to detect a signal of DM particle direct interaction with the detector, and
- to determine its mass and interaction cross section, or else
- to experimentally exclude the broadest accessible ranges of both quantities

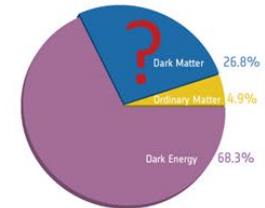

Recommendation 1. The search for dark matter with the aim of detecting a direct signal of DM particle interactions with a detector should be given top priority in astroparticle physics, as a positive measurement will provide the most unambiguous confirmation of the particle nature of dark matter in the Universe.

L. Roszkowski, APPEC feedback meeting, 2 Feb 2021

Supersymmetry is still a very viable possibility (direct detection experiments have complementary sensitivity to colliders; can be more sensitive since not limited by beam energy)

Slide from APPEC community feedback meeting Feb 2021
<https://indico.cern.ch/event/982757/contributions/4140443/>

Claims that thermal WIMP as DM is "disfavored" are unfounded.

**"GeV-scale thermal WIMPs:
Not even slightly ruled out"**

3 ktonne-year dark matter search with argon (ARGO) allows probing down to the neutrino floor

Next decade(+)

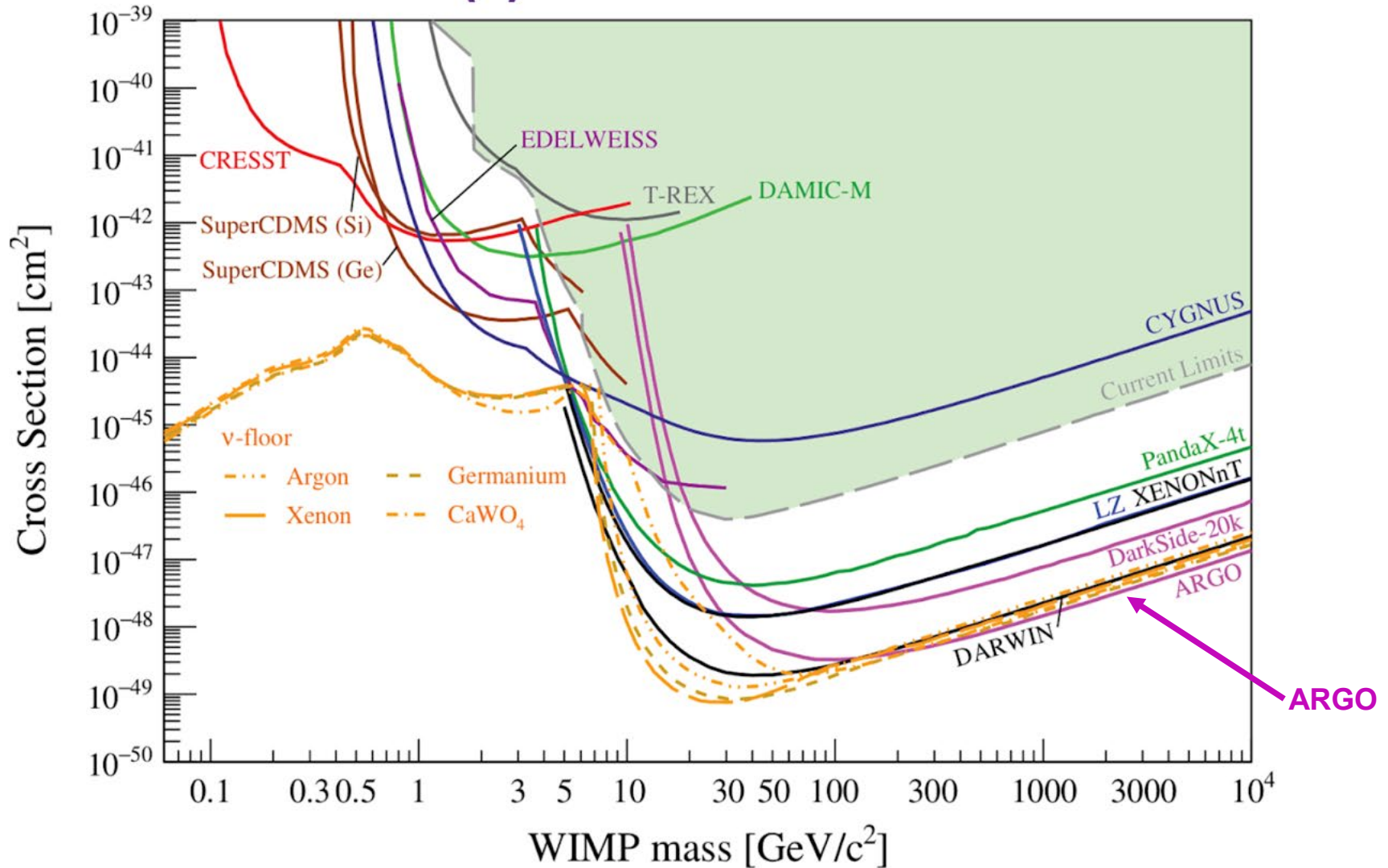

Global Argon Dark Matter Program formed in 2017

Over 400 researchers from

- DarkSide
- DEAP
- ArDM
- MiniCLEAN

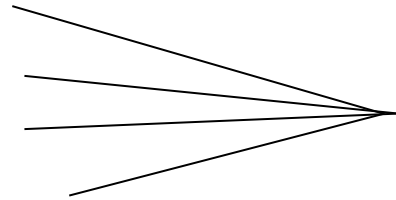

DS-20K
@LNGS



ARGO
@SNOLAB

- GADMC includes over 400 researchers from 69 institutions in 14 countries
- Completion of current science program with DEAP
- Joint collaboration on DS-20k at LNGS (200 tonne-years) starts 2025
- Joint collaboration on ARGO detector to reach neutrino floor at SNOLAB

ARGO: approximately 300 (fiducial) tonnes for 3 kt-year argon DM search, large detector with photodetectors ($\sim 100 \text{ m}^2$) for photon detection.

Develop concept over next few years.

Neutrino backgrounds in xenon and argon

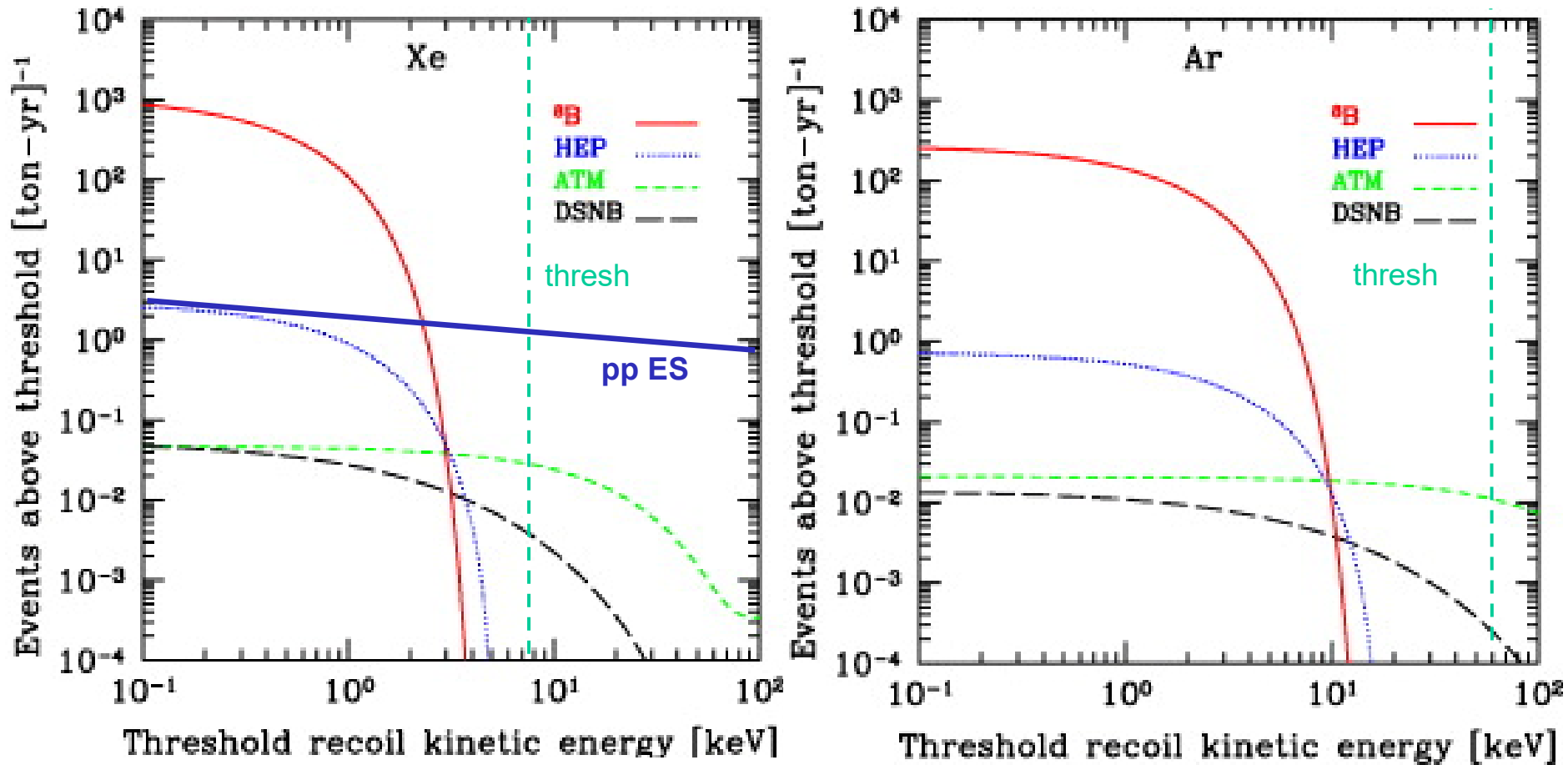

Coherent scattering from Strigari, New J. Phys. 11 (2009) 105011

0.5 event/tonne-year pp background in xenon, after 0.995 discrimination

ARGO-Canada collaboration

Members (*= NSERC applicant/co-applicant)

- *Serge A. Charlebois (Faculty, Sherbrooke)
- *Jean-Francois Pratte (Faculty, Sherbrooke)
- *Audrey Corbeil Therrien (Faculty, Sherbrooke)
- *Mark Boulay (Faculty, Carleton)
- *Aksel Hallin (Faculty, Alberta)
- *Philippe Di Stefano (Faculty, Queen's)
- *Chris Jillings (Faculty, Laurentian and SNOLAB)
- *Szymon Manecki (Faculty, Laurentian, Queen's and SNOLAB)
- *Art McDonald (Faculty Emeritus, Queen's)
- *Fabrice Retiere (Senior Research Scientist, TRIUMF)
- *Pierre Gorel (Faculty, Laurentian and SNOLAB)
- *Nigel Smith (Faculty, Laurentian, Queen's, Imperial College and CIFAR fellow)
- David Sinclair (Faculty Emeritus, Carleton)
- Simon Viel (Faculty, Carleton)
- Yue Zhang (Faculty, Carleton)
- Peter Skensved (Senior Researcher, Adjunct Faculty, Queen's)

Funded as NSERC SAP Project this round for 2021-2023

Near-term ARGO activities

Develop detector concept and full background budget. Simulations, studies of cosmogenics at SNOLAB to 10^{-49} cm² level, evaluation of detector response and constraints on photodetector requirements, evaluation of systematics related to CNNS systematics at neutrino floor. Evaluate detector sensitivity.

Determine potential footprint and infrastructure requirements.

Further development of “photon to digital converters, PDCs”, including further development of direct VUV detection (and simulation of detector response). Development of real-time intelligent data acquisition system.

Prototyping PDCs in liquid argon

Continued development of underground argon, first used by DS-20k, then ARGO, including long-term storage, sensitive assay at SNOLAB

Noble Liquid Detector Facility (2017 CFI IF)

Carleton/TRIUMF/UBC/McGill/Sherbrooke – 9M\$ 2017 CFI IF

“Cryogenic and Light Readout Facility for future development of Noble Liquid Detectors”

- Development of large area 3D SiPMs - Sherbrooke
- New Cryogenic Facility will allow rapid R&D in noble liquids – Carleton **COLD Lab**
- Optics and UV light characterization – TRIUMF/UBC
- Characterization and testing of integrated large area 3D SiPMs - McGill

Advantages of Digital SiPMs:

- Signal processing at sensor level allows much simpler implementation
- All-digital system not affected by electronic noise encountered in analog
- Ability to disable noisy Single Photon Avalanche Diodes (SPAD)
- Active quenching suppresses essentially all after-pulsing
- Lower power consumption
 - no event no power for digitizing
- Excellent potential for time resolution
 - ~100ps

Going further to enable large scale detectors: A fully digital photodetector module

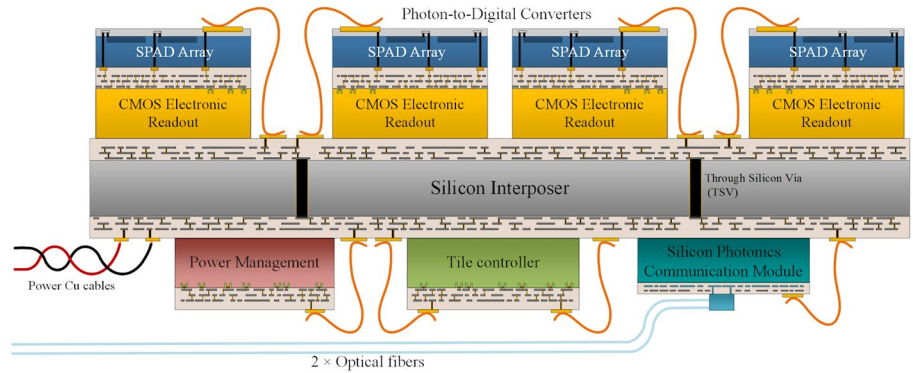

To reduce wire count and mass:

- On tile power management
- Bidirectional digital optical communication

Low background and cryogenic operation:

- silicon based tile substrate - low background
- CTE matched to silicon - PDCs and ASICs

Leverages past CFI and NSERC funding:

Wafer level development (SPAD)

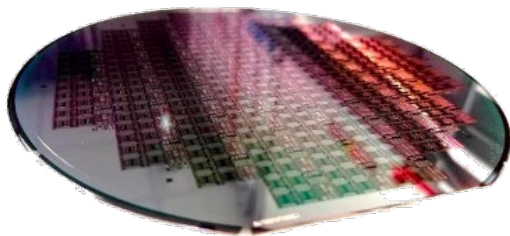

CMOS readout
(2 revisions)

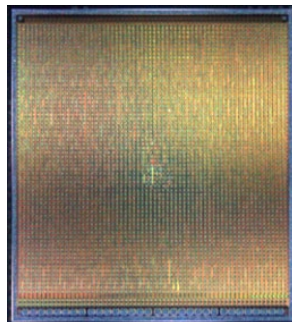

Sensitivity enhancement
for direct detection

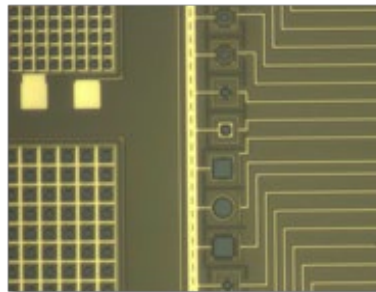

Silicon interposer development

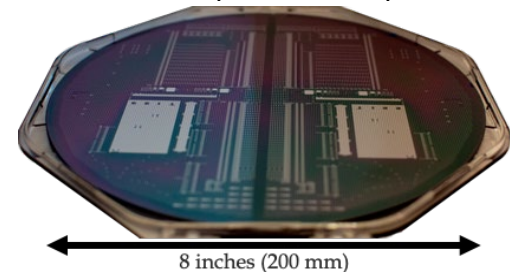

Recent progress – Carleton and upcoming digital test

30 kg LAr Argon-1 @
Carleton with analog SiPMs
(W2-11 Gallacher)

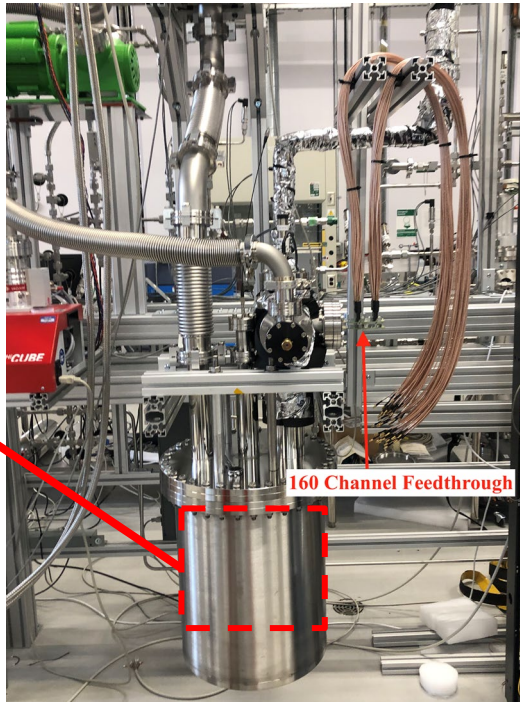
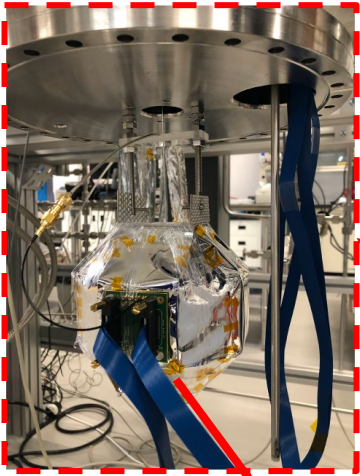

160 Channel Feedthrough

Getting ready for first LAr testing of Digital SiPMs
from **U. Sherbrooke**

- coding FPGA
- adapting the board size and connectors to the setup

2D PDC prototypes

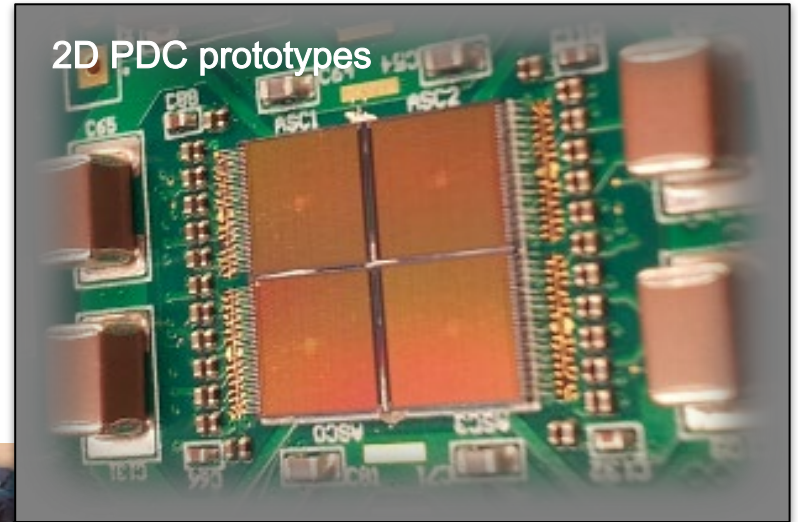

Pulse Charge PE Estimate Argon1

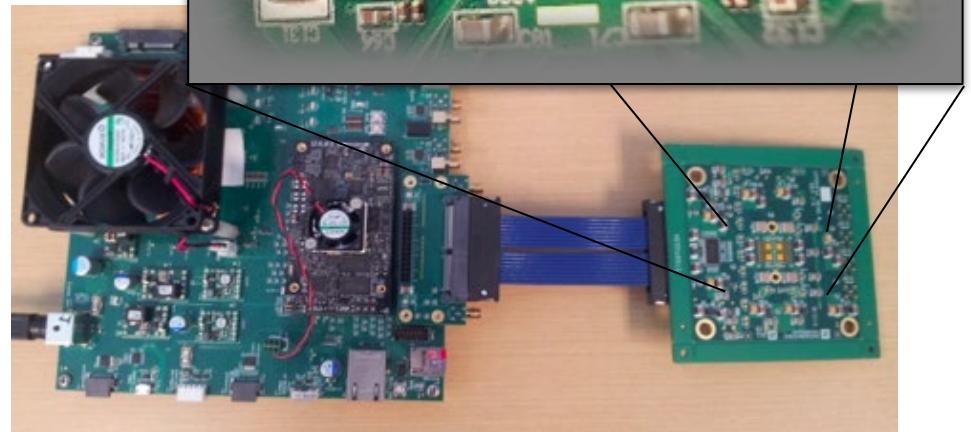
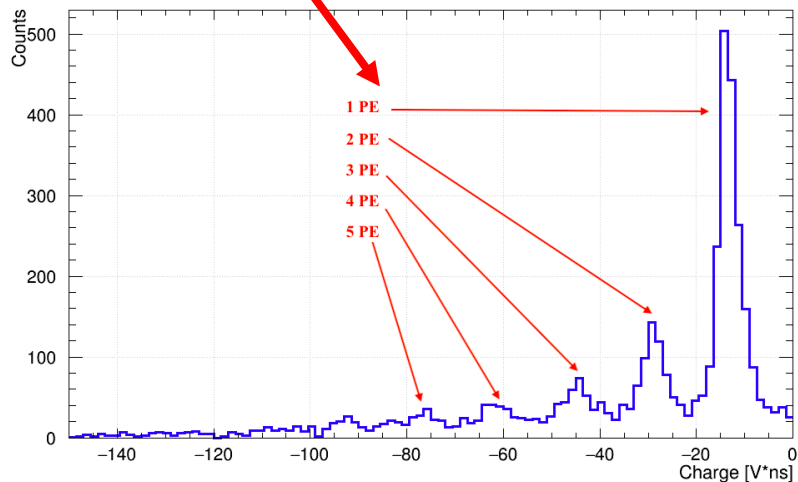

Underground argon, low in ^{39}Ar , for DS-20k and ARGO,
Planning long-term storage at SNOLAB: **ARGUS** = ARGon Underground Storage

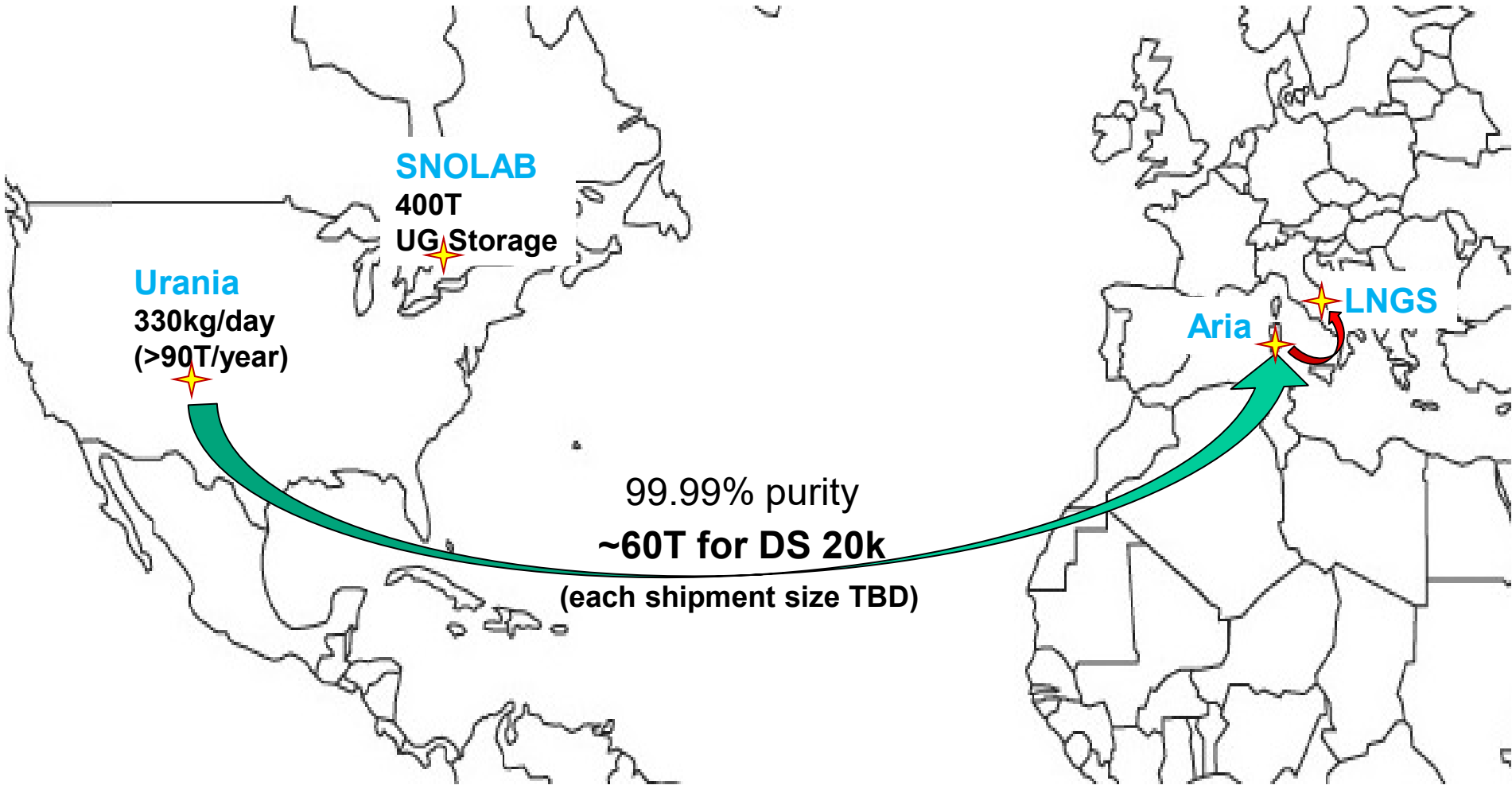

ARGUS concept (preliminary)

ORTHOGRAPHIC VIEW OF COMPLETE STORAGE DRIFT

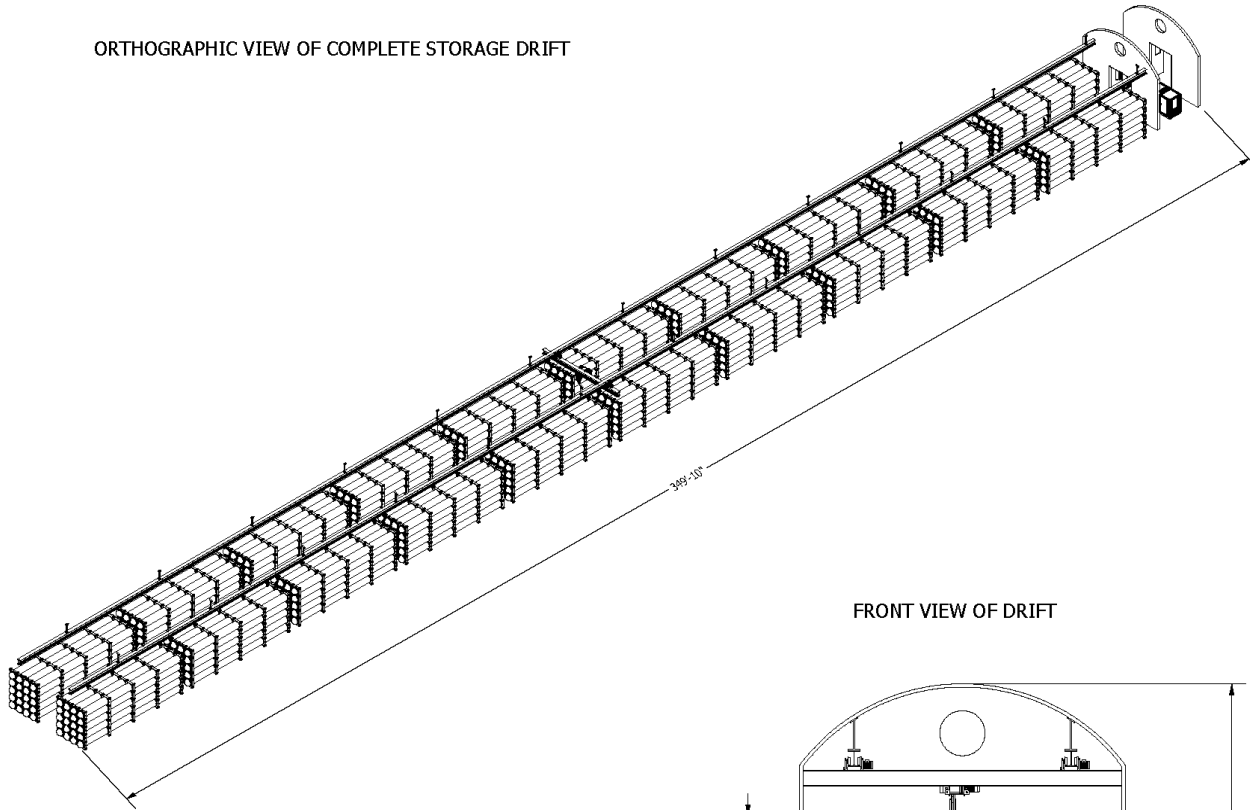

TOP VIEW OF SINGLE GROUP

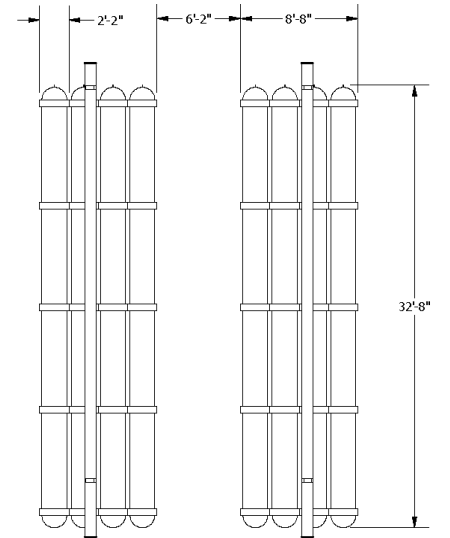

FRONT VIEW OF DRIFT

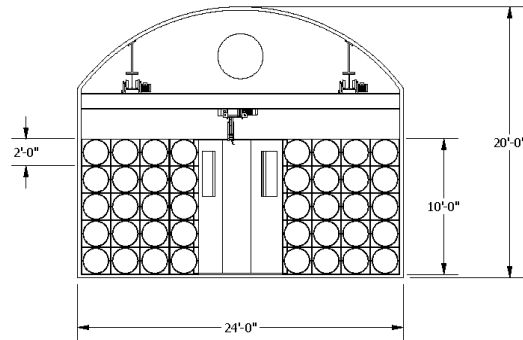

DRAWN: DATE:	SUBMITTED: DATE:	APPROVED: DATE:
morrison		

<p>1039 Regional Road 24 Creighton Mine #9, LIVELY, ONTARIO, CANADA, P3Y 1N2</p>	FRACTIONS - ± 1/16" U.N.O X.X - ± 0.01 U.N.O X.XX - ± 0.005 U.N.O X.XXX - ± 0.003 U.N.O ANGLES - ± 30' U.N.O SURFACE FINISH - 125 RMS U.N.O	STATE UNITS INCHES MATERIAL	PRELIMINARY SHEET SIZE B1 SCALE 1/300
	TITLE PROPOSED ARGON STORAGE DRIFT	AUTHCR mmorrison	LOCATION DATE 2019-05-11

Summary and Conclusions

Argon DM program: completion of DEAP; DS-20k; ARGO.

Completing DEAP detector upgrades with additional running to demonstrate background targets. Global Argon Dark Matter Collaboration pursuing DS-20k (LNGS 2025) followed by ARGO at SNOLAB with sensitivity to neutrino floor. **High-mass WIMP search to neutrino floor is very strongly motivated.** Argon has unique advantage due to excellent PSD.

Program builds on past investments, including substantial CFI funding for development of next-generation noble detectors; enables very well-motivated long-term science program.

Exciting technical development of **photon-to-digital converters** a game-changer for ARGO with many potential applications.

Strong Collaboration, with a unique mix of expertise in particle physics, detector development, electrical engineering, microfabrication and smart data handling, both in Canada and within the 400-member Global Argon Dark Matter Collaboration.

Thanks for the strong support from NSERC, CFI, McDonald Institute, SNOLAB and TRIUMF.

END