



CAP Congress  
Kingston, ON  
29 May – 2 Jun, 2017



# Electrical Resistivity of Molten Ni at High Pressures and Preliminary Results for Liquid Fe

R. E. Silber, R. A. Secco and W. Yong

Department of Earth Sciences, University of Western Ontario,  
London, Ontario, Canada, N6A 5B7

# Motivation

- Transport properties of liquid Ni and Fe at high P have important geophysical implications for terrestrial planetary interiors (e.g. dynamo, core heat flow, core evolution)
- Ni is a close electronic analogue of Fe (similarities of ferromagnetic and paramagnetic states)
- The electrical resistivity of solids and liquids gives insight into electronic structure and properties of materials

# Objective

- **The aim** of this study is to test experimentally if the **electrical resistivity of a pure Ni and Fe is constant along its P-dependent melting boundary** (Stacey and Anderson, 2001).
- If valid for 3d transition metals, then this behavior could serve as **a practical tool for low P studies to assess electrical resistivity of Earth's core** (Earth's inner core boundary is a melting boundary of Fe alloy).

# Review of Previous Ni Studies at 1atm

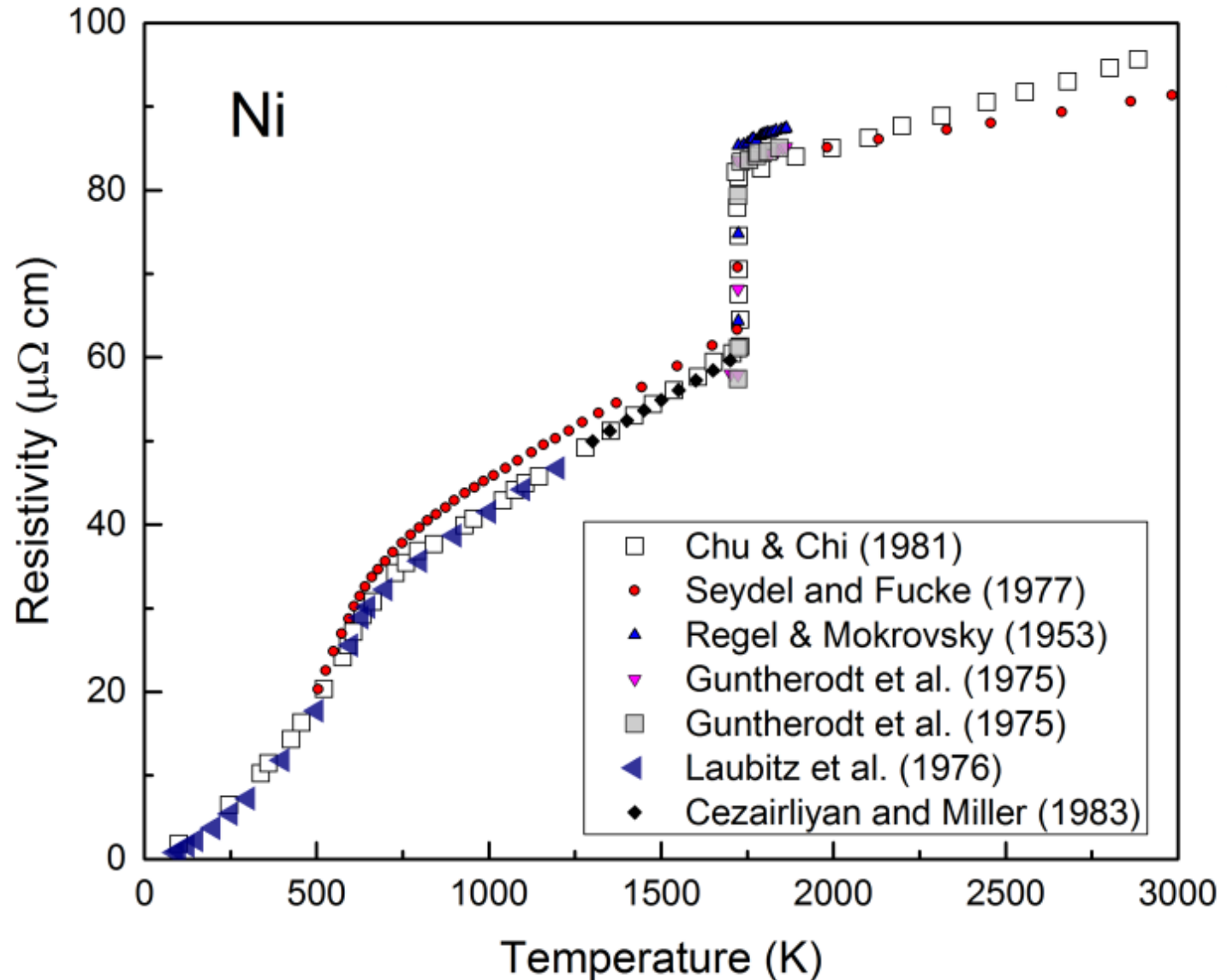

# Methods and Experimental Challenges

- ✓ Control over the molten metal sample containment and geometry
- ✓ Reactivity with and diffusion of molten metal into its container
- ✓ Thermocouple - molten sample contamination

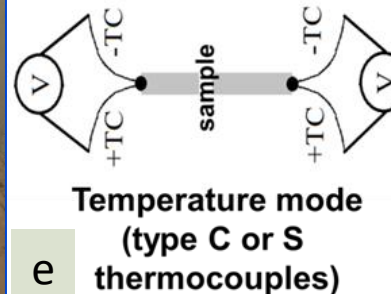
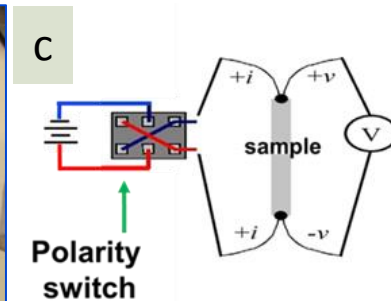
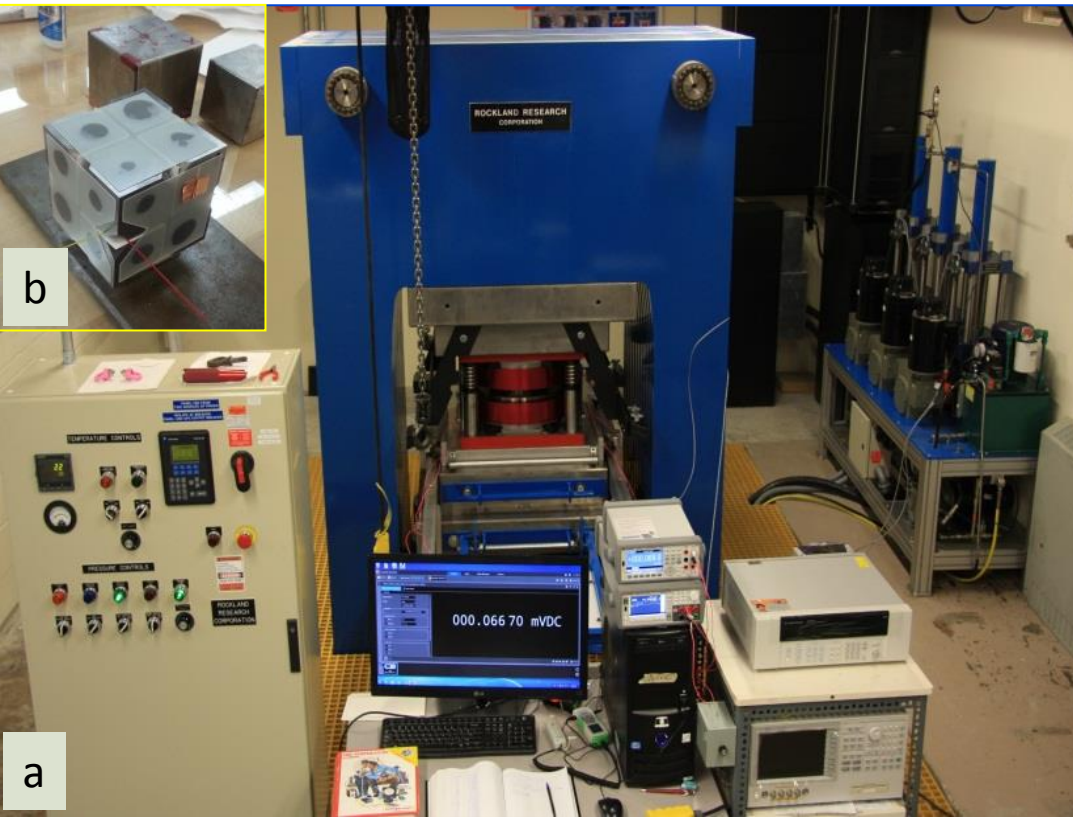

- (a) Large volume 3000 ton press.
- (b) Assembled WC cubes containing the sample cell.
- (c) (c-e) Schematic of polarity switch (c), depicting the voltage (c) and temperature mode (e).
- (d) fast acquisition meter

# Methods - Cont'd

- Everything should be made as simple as possible, but not simpler.*  
(Albert Einstein)

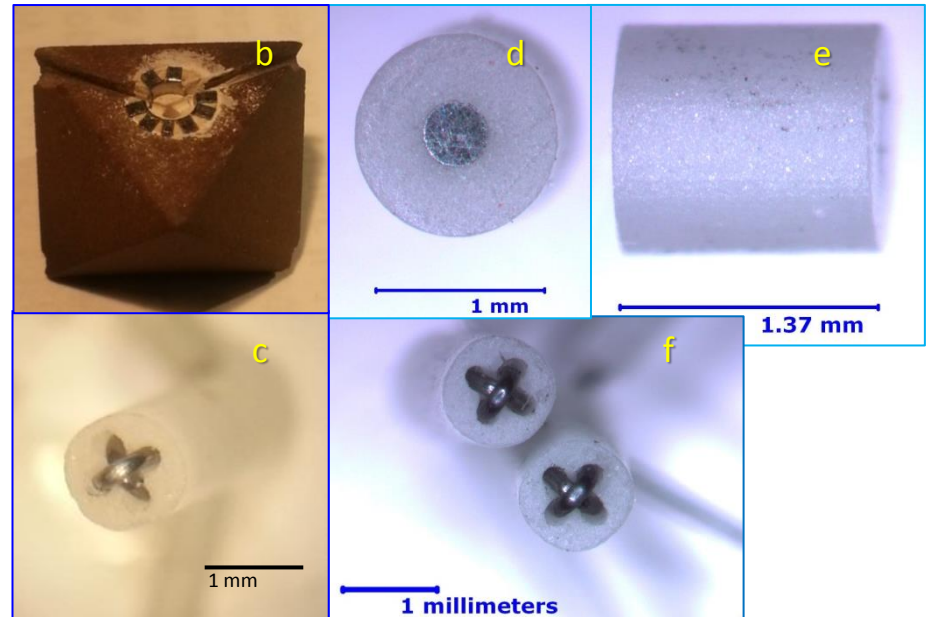
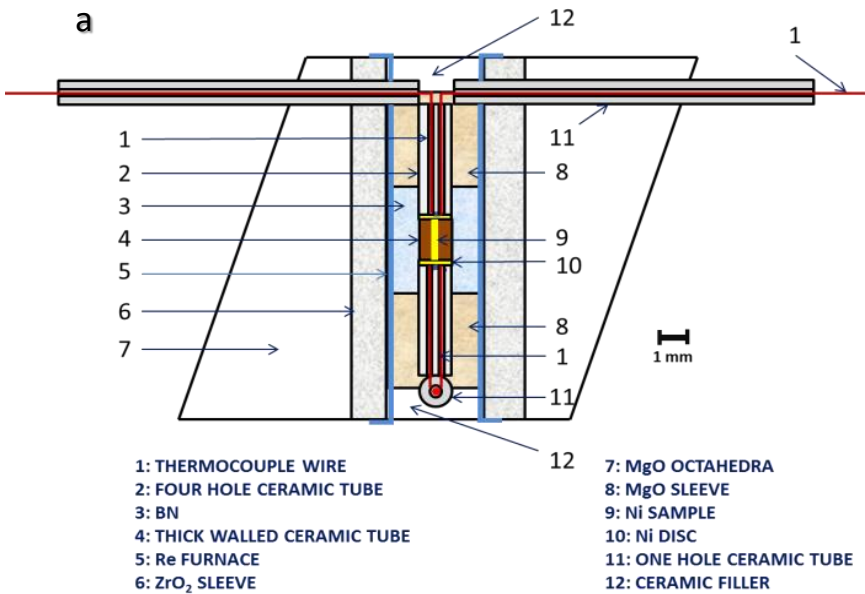

(a) Cross-section of experimental cell. (b) MgO cell. (c, f) 4-hole ceramic tube with TC emplaced wires. (d, e) Thick walled ceramic tube hosting the Ni or Fe sample.



# Methods – Cont'd

Electron microprobe image of a sample quenched at melting point. W/Re thermocouples appear white. The composition data are shown on the left. (4 GPa, 1840 K)



Recovered and sectioned sample.  
(Ni-32, 3 GPa, 1770 K)

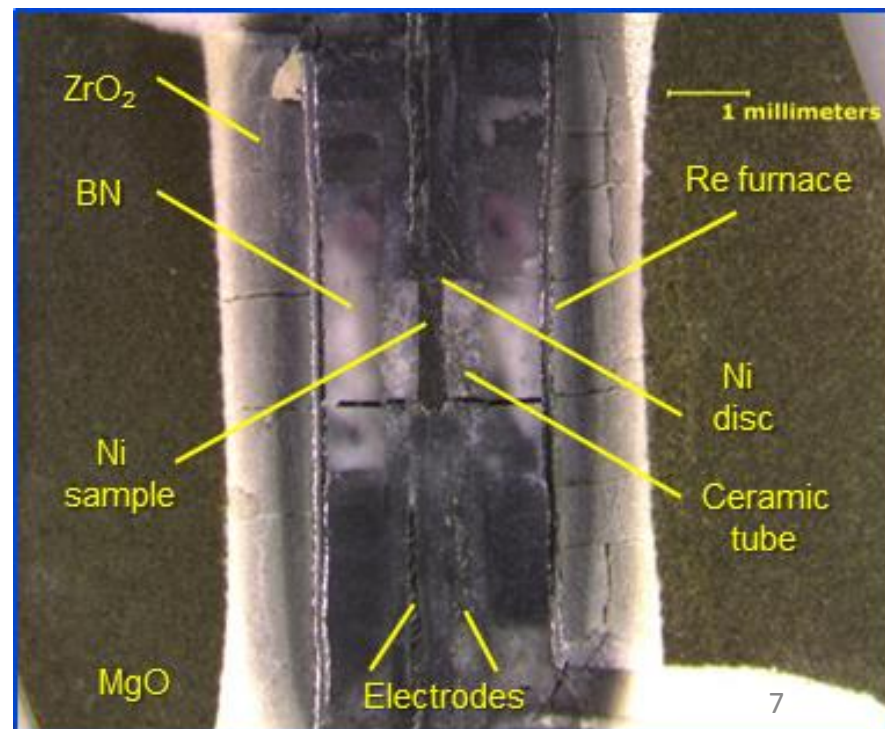

# Results

- **Electrical resistivity** of Ni at high P is **invariant along the melting boundary up to 9 GPa** within experimental uncertainty

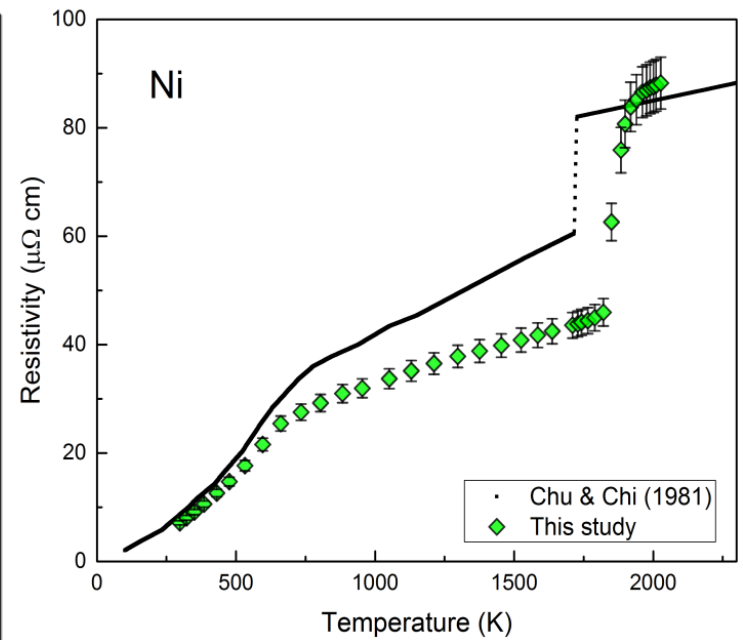
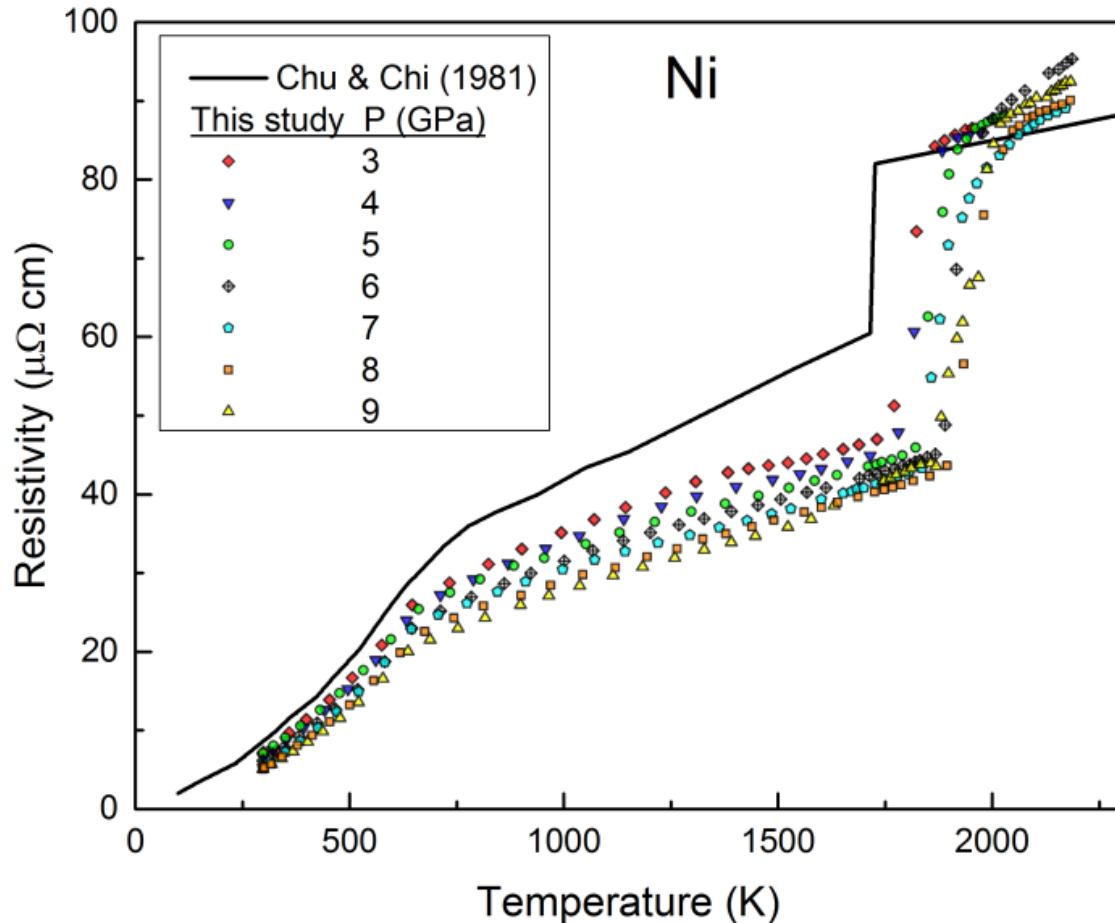

Representative error bars for 5 GPa run in this study (error in T is within the symbol size).



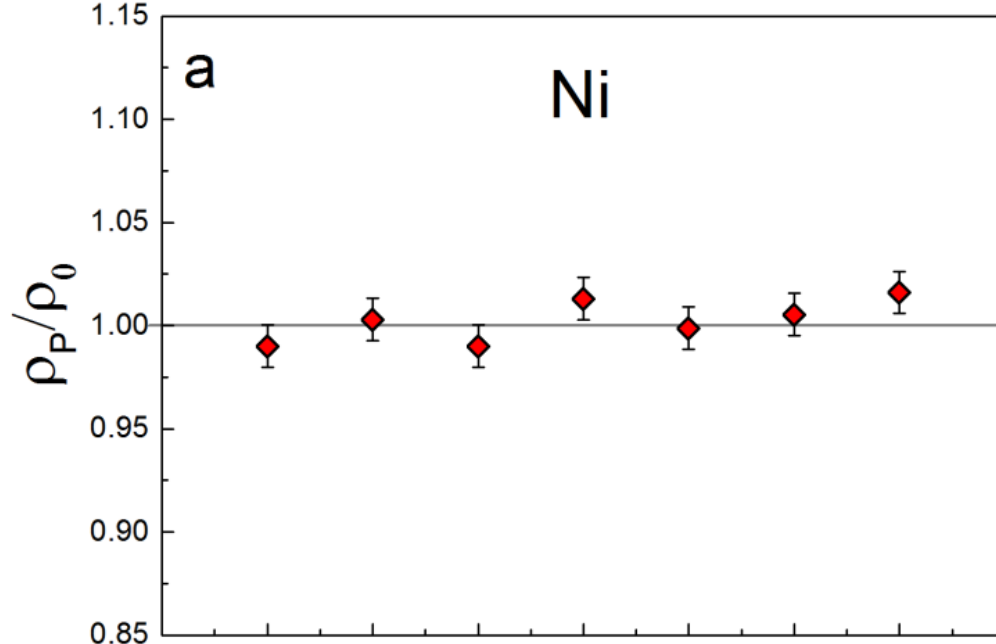

(a) The ratio of electrical resistivity of molten Ni at pressures 3 – 9 GPa ( $\rho_P$ ) and at ambient pressure ( $\rho_0$ ).

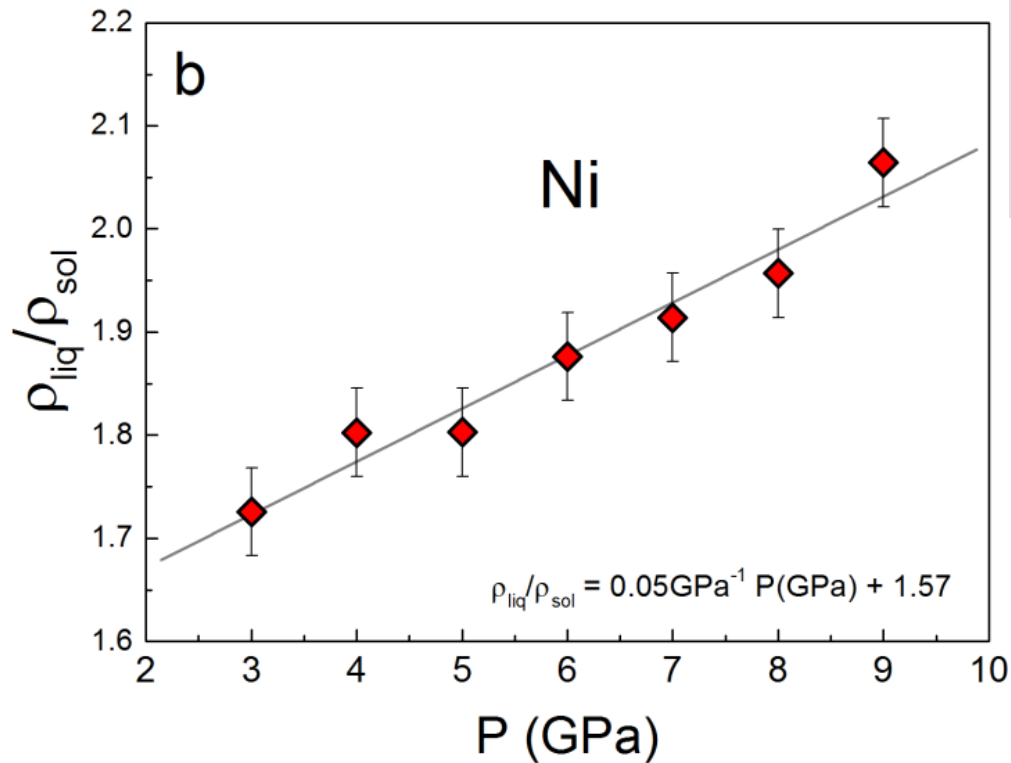

(b) The ratio of electrical resistivity of liquid to solid Ni as a function of pressure.

# Results - Cont'd

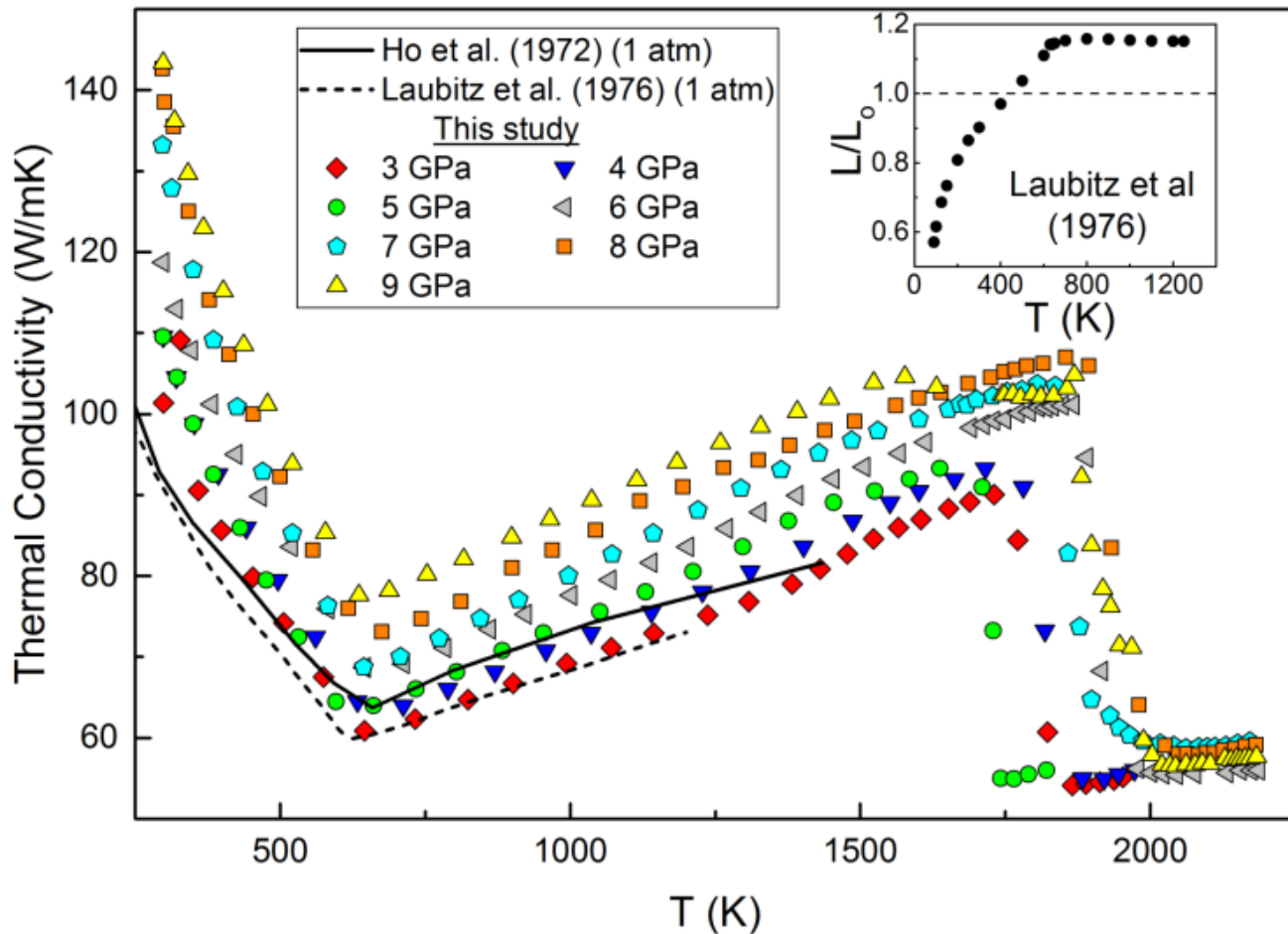

Wiedemann-Franz law

$$k = \frac{LT}{\rho}$$

$k$  - thermal conductivity  
 $L$  - Lorenz number  
 $T$  - temperature  
 $\rho$  - resistivity

Calculated electronic thermal conductivity for solid and liquid Ni at pressures 3 - 9 GPa using the Wiedemann-Franz law and the Sommerfeld value of the Lorenz number ( $2.44 \cdot 10^{-8} \text{ W}\Omega\text{K}^{-2}$ ).

The inset is the ratio of the experimentally derived temperature dependent Lorenz number for Ni and the Sommerfeld value given above.

# Discussion

- Possible explanation(s) of invariant electrical resistivity of Ni along the melting curve:
  - **constant Fermi surface** and an **invariant electron mean free path** (offset of P and T effects)?
  - role of **local symmetry structures** observed in molten transition metals with unfilled d-band?
- Can Fe be expected to mimic Ni behaviour?

# Electrical Resistivity of Solid and Liquid Fe at High Pressure

- Even more challenging
- Different approach from Ni (use of W and Pt discs to contain the liquid)
- Low P-T phase transitions

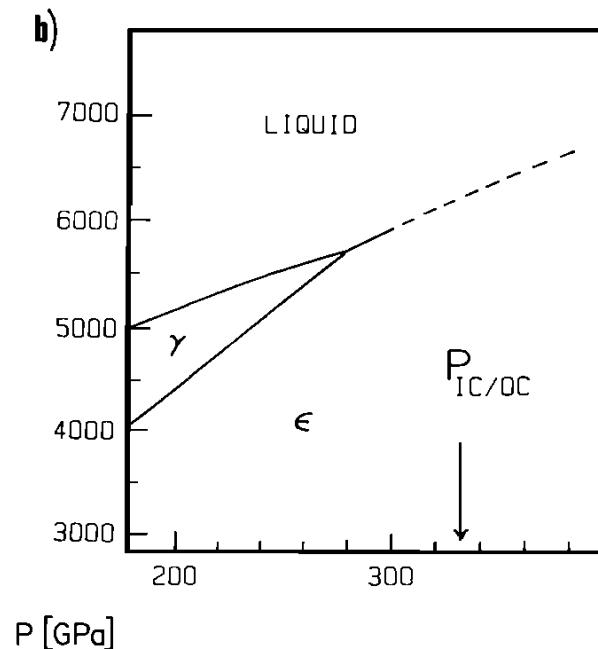
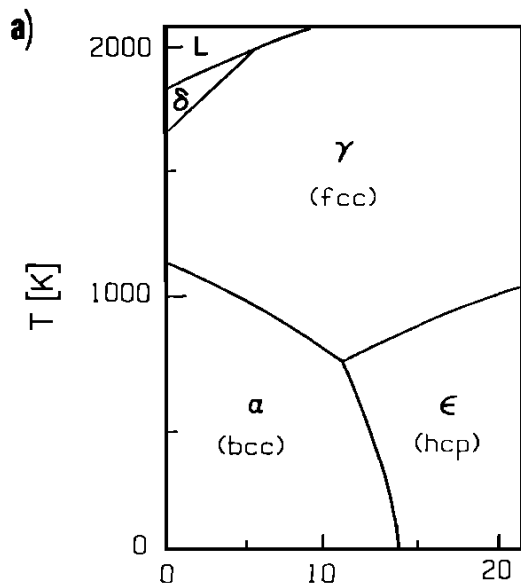

P, T phase equilibrium lines of the solid polymorphs of Fe and liquid Fe (a) remote from, and (b) close to, the P, T conditions of the Earth's core.

(Secco and Schloessin, 1989; after Anderson 1986)

# Comparison with previous studies

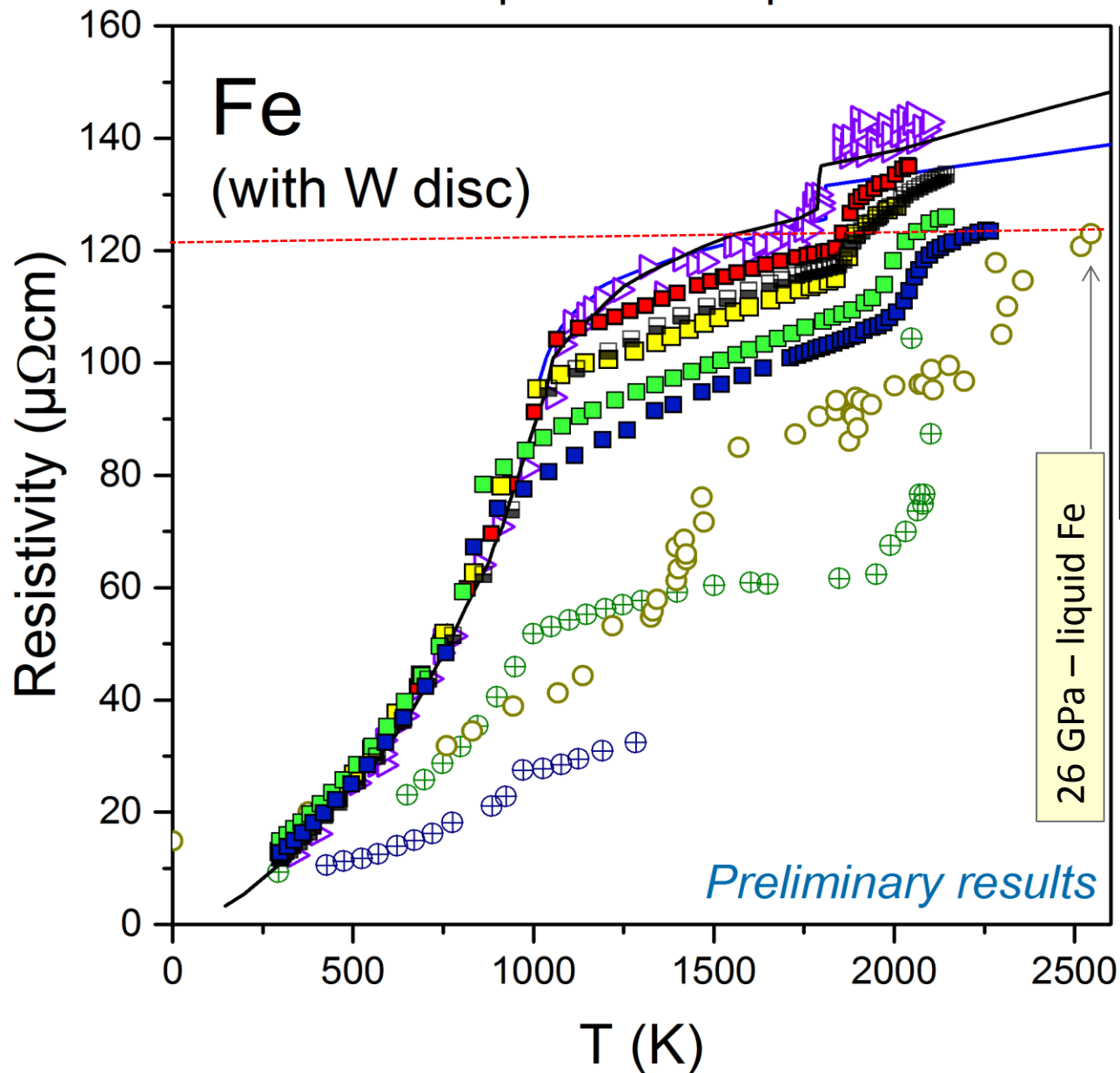

- Seydel & Fucke (1977)
- △ Van Zytveld (1980)
- Chu & Chi (1981)
- ⊕ Deng et al. (2013) 5 GPa
- ⊕ Deng et al. (2013) 7 GPa
- Ohta et al. (2016) 26 GPa
- This study (3 GPa, W)
- This study (5 GPa, W)
- This study (6 GPa, W)
- This study (9 GPa, W)
- This study (11 GPa, W)

# Discussion and Conclusion

- Our results suggest the importance of pre-melt crystalline structure on behaviour of initial melt.
- Geophysical implications (e.g. dynamo, core heat flow...).
- However, the role of local structures in the initial Fe and Ni melt, along with the electron scattering mechanisms, and competing offsetting effects of P and T need further theoretical investigation.

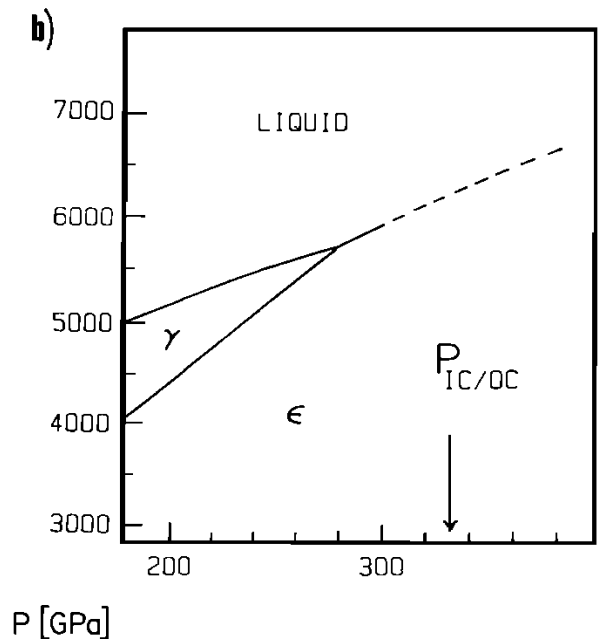
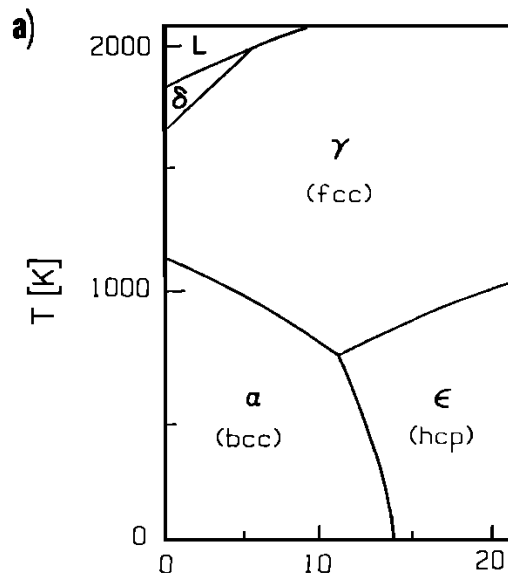
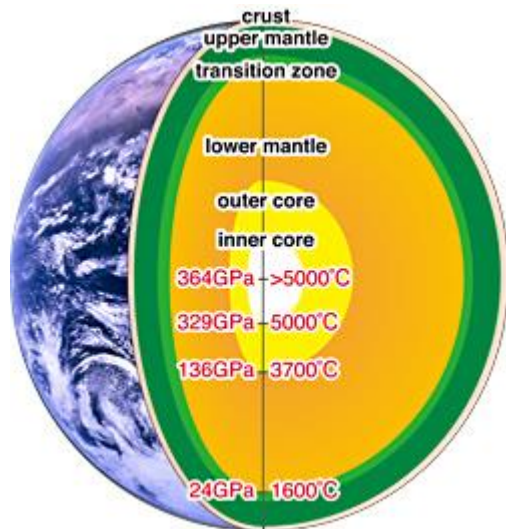

# Thank You!

## Questions?

### Acknowledgments:

We thank J. Jacobs for his assistance in fabrication of parts, S. Woods for preparing the recovered samples for electron microprobe analysis, and M. Beauchamp for running EMP analysis. RES also acknowledges useful discussions with T. Officer and I. Ezenwa. RAS acknowledges Canada Foundation for Innovation and NSERC for equipment and research funding, respectively.





# Supplemental Material

# Previous studies

# Fe

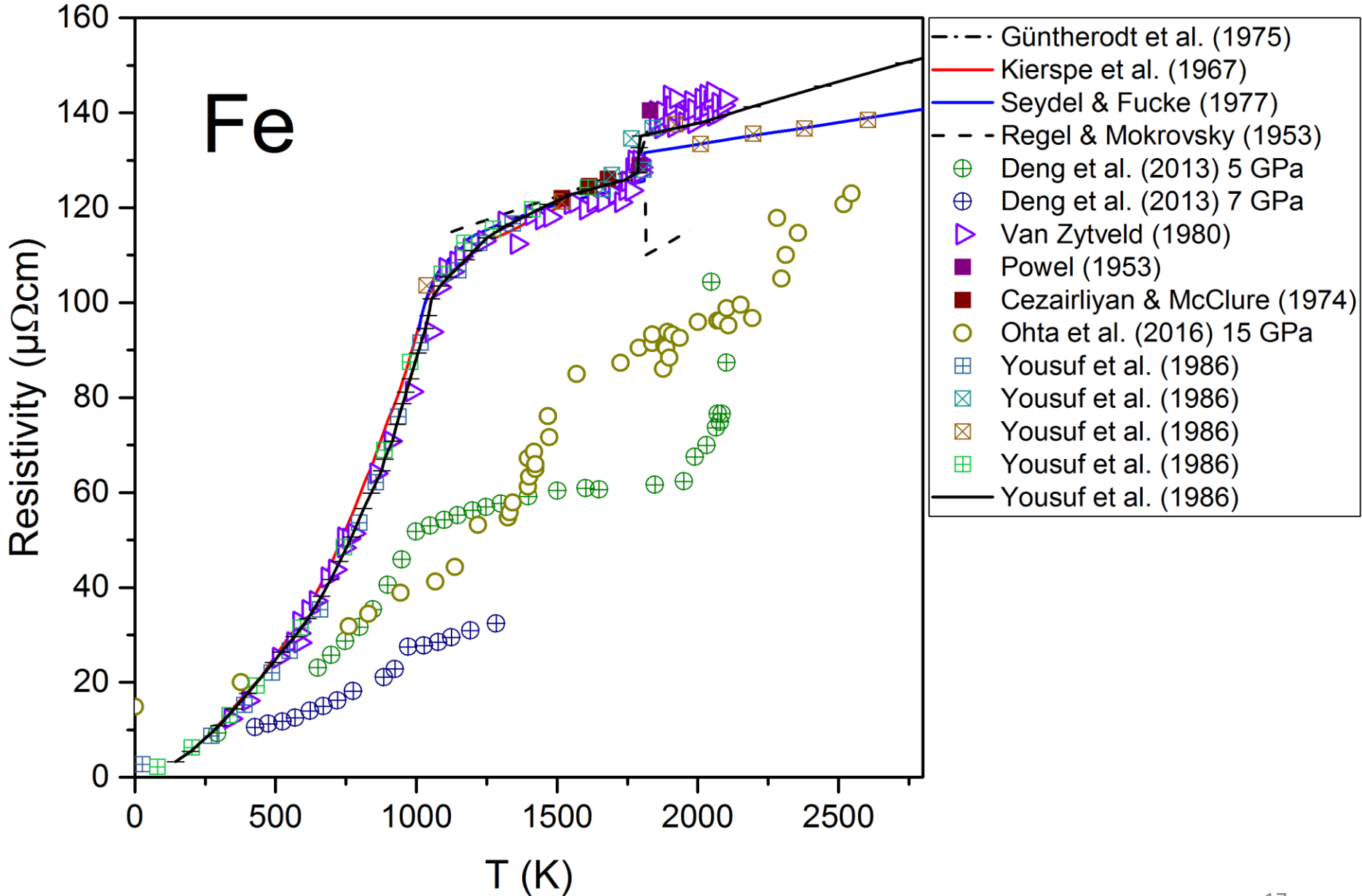

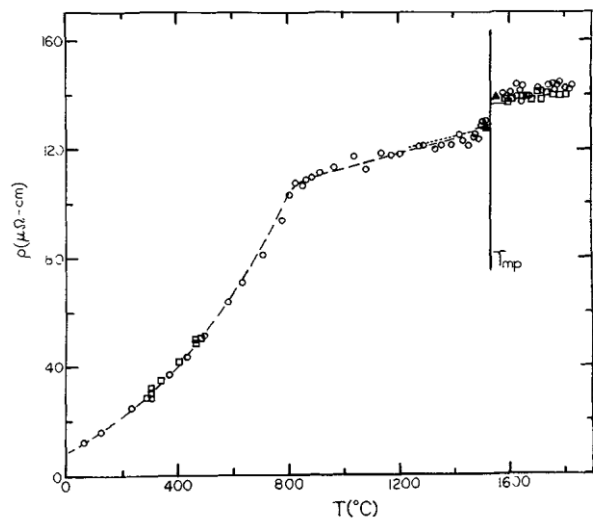

Van Zytveld, (1980)

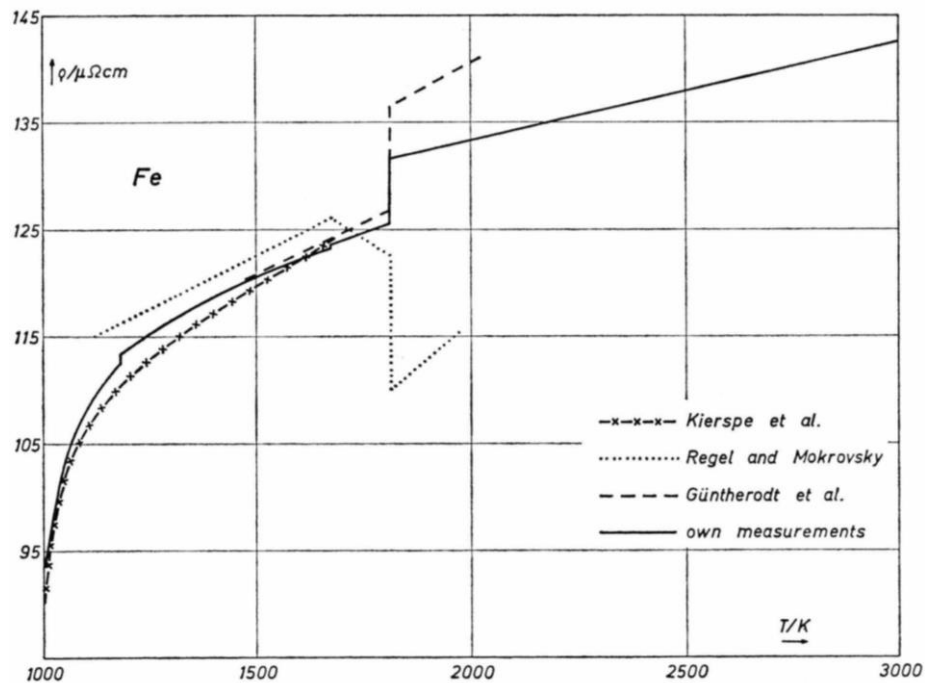

Seydel and Fuccke, (1977)

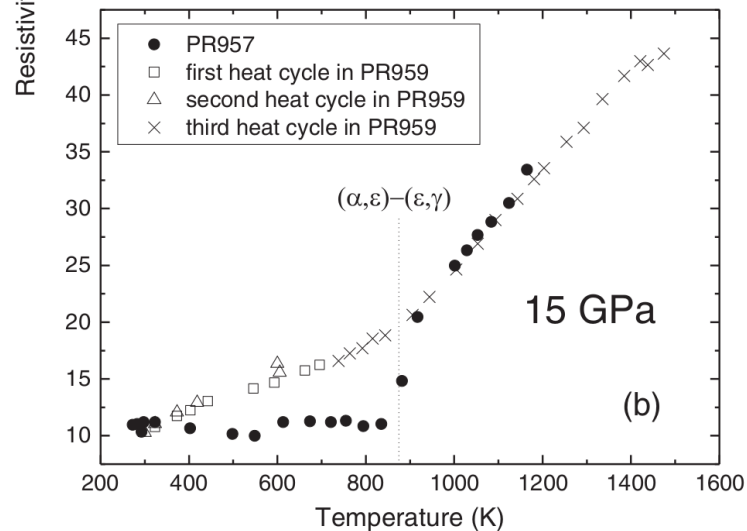
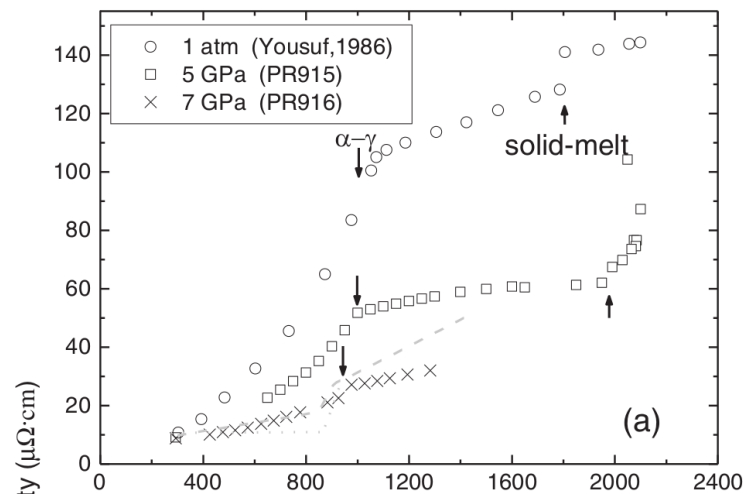

# Comparison with previous studies

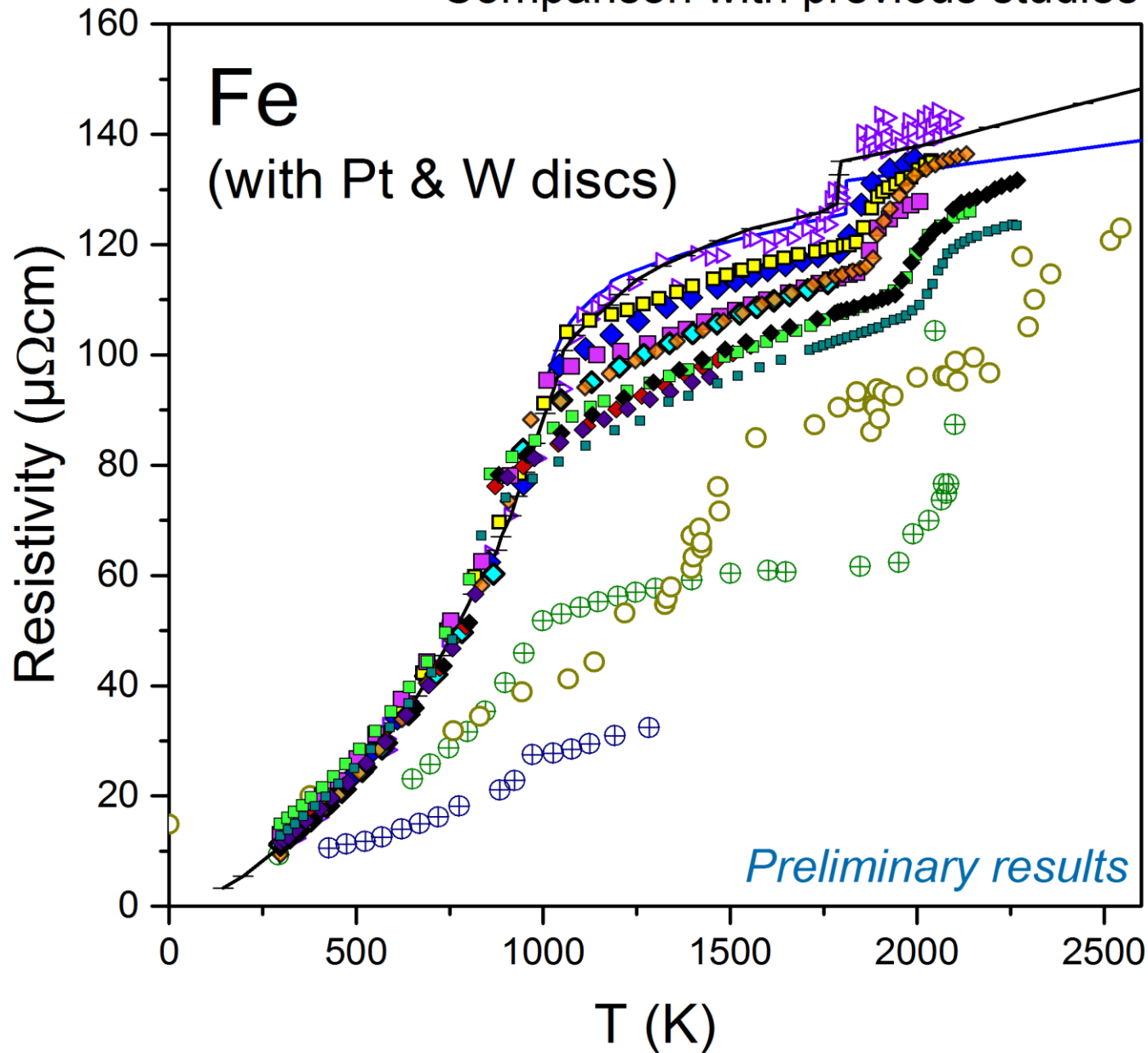

- Seydel & Fucke (1977)
- Chu & Chi (1981)
- △ Van Zytveld (1980)
- ⊕ Deng et al. (2013) 5 GPa
- ⊕ Deng et al. (2013) 7 GPa
- Ohta et al. (2016) 26 GPa
- ◆ This study (3 GPa, Pt)
- This study (3 GPa, W)
- This study (6 GPa, W)
- ◆ This study (6 GPa, Pt)
- ◆ This study (6 GPa, Pt)
- ◆ This study (9 GPa, Pt)
- This study (9 GPa, W)
- ◆ This study (9 GPa, Pt)
- ◆ This study (9 GPa, Pt)
- This study (11 GPa, W)

# Comparison with previous studies

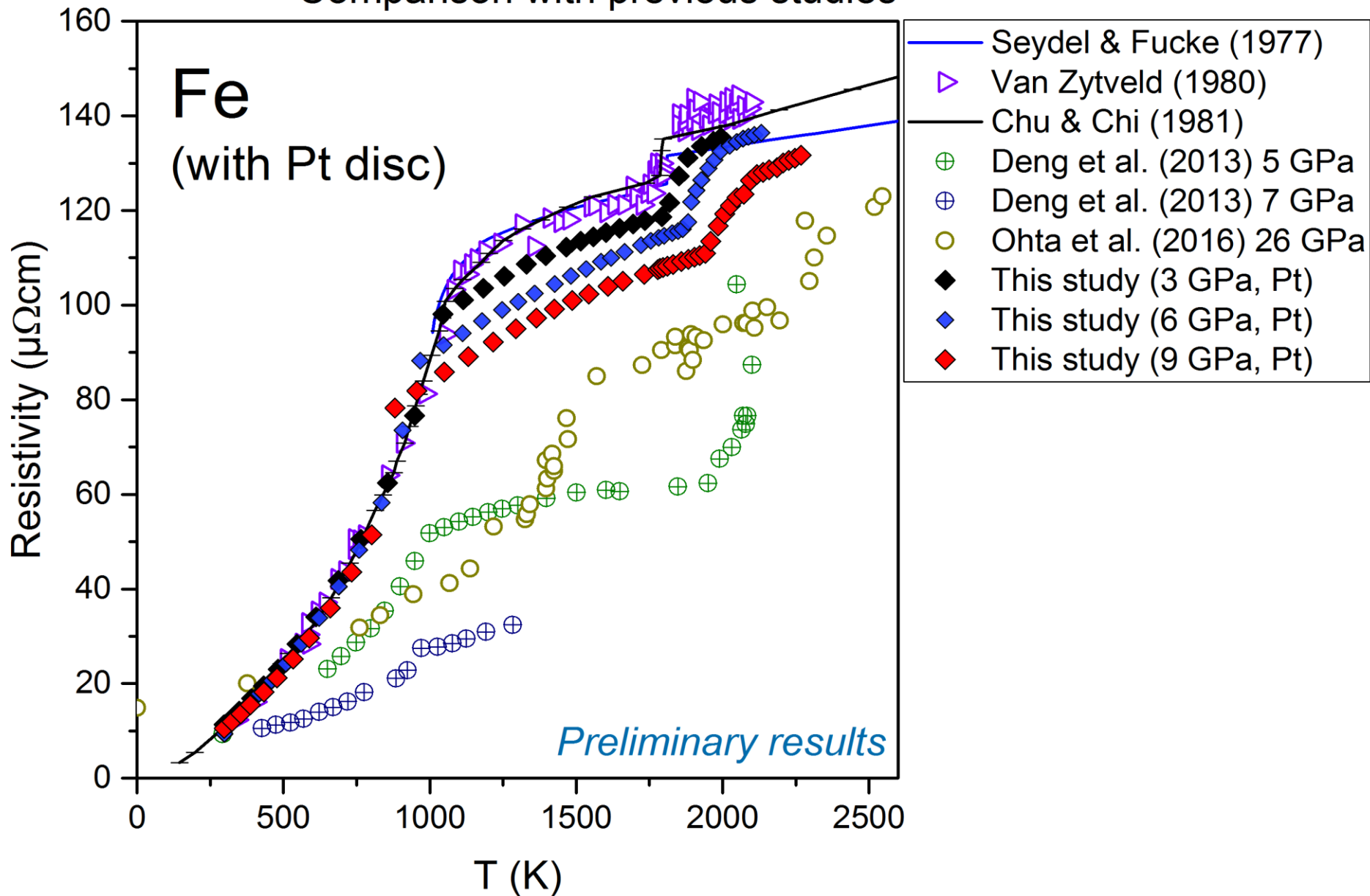

# Pt-disc (6 Gpa, heated above Curie T)

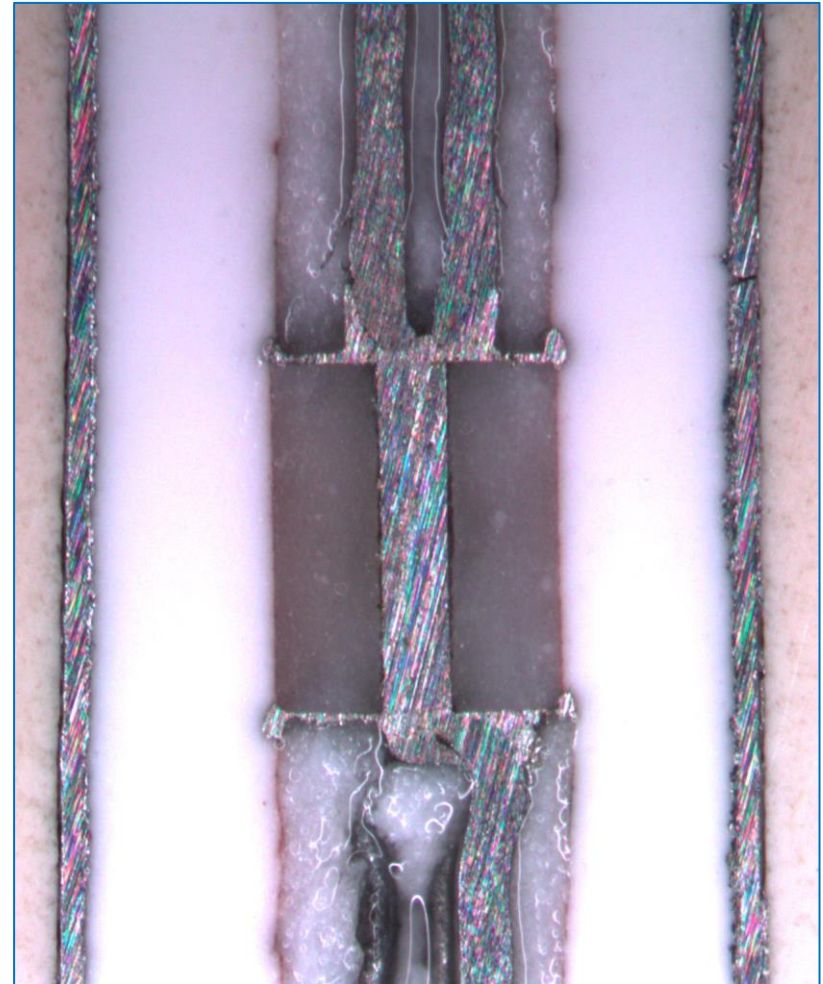
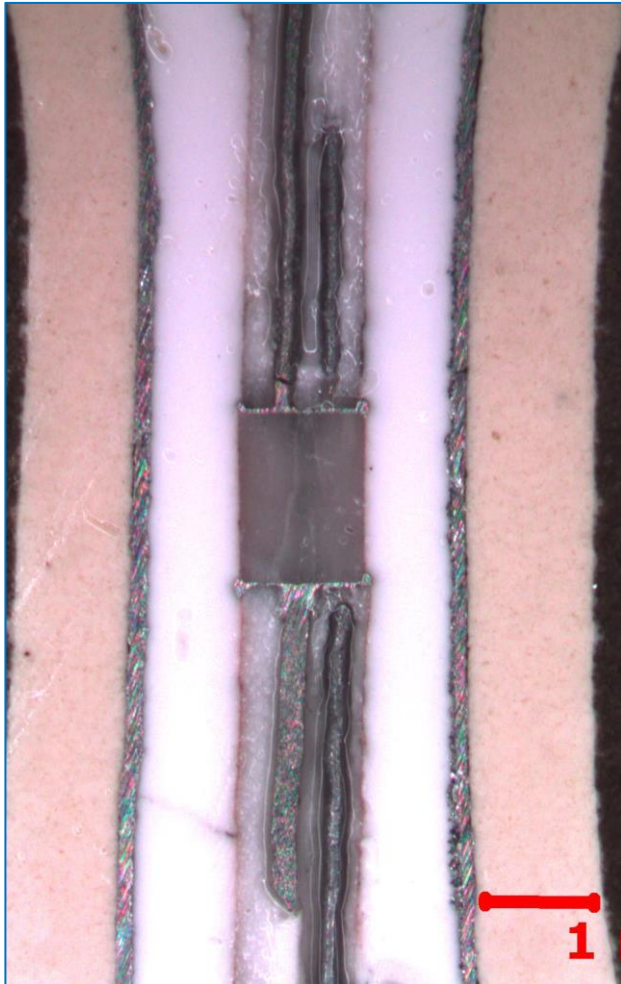



# Pt-disc (6 GPa and Heated Above Curie T)

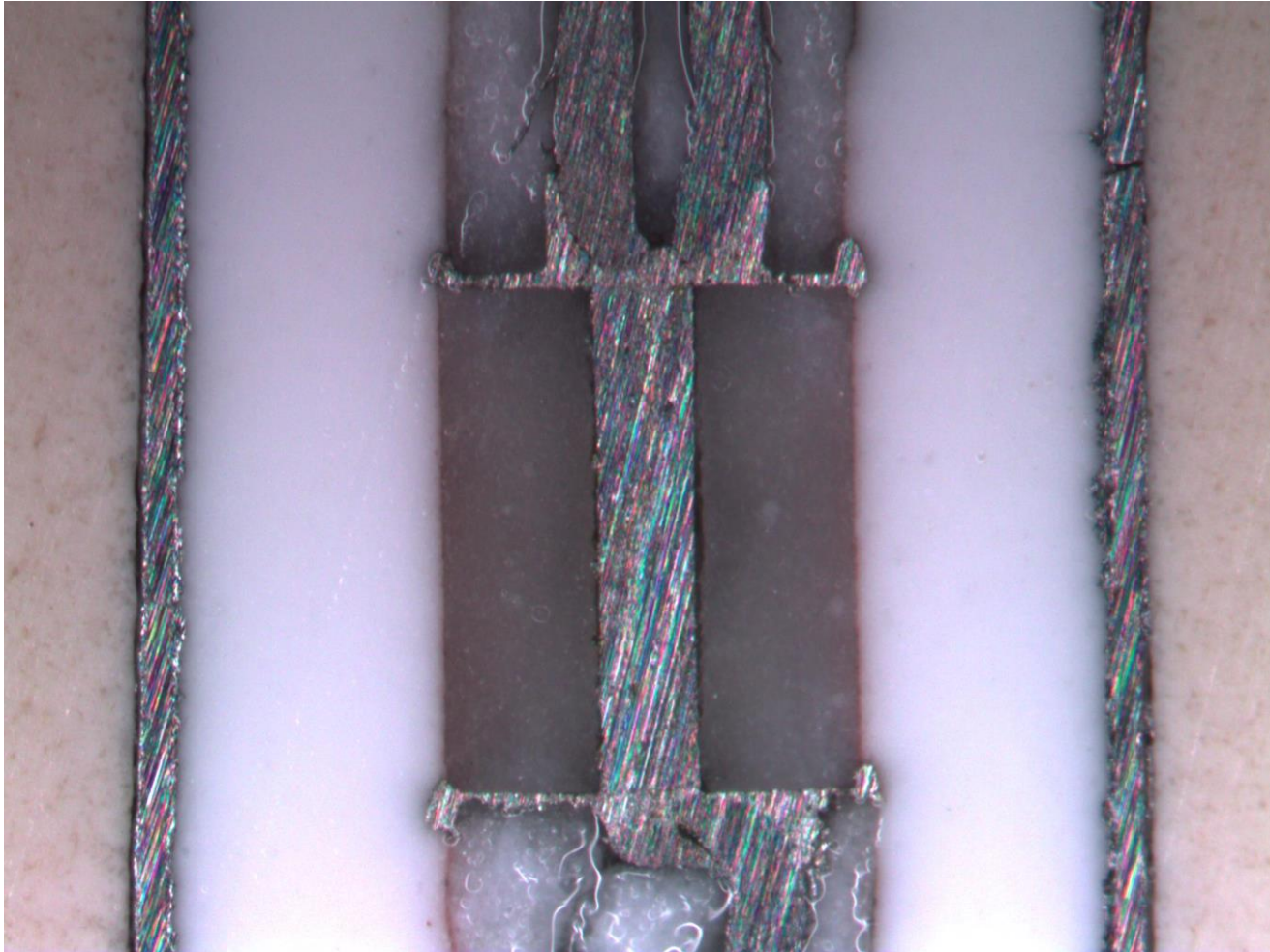



# Pt-disc (9 GPa and Heated Above Curie T)

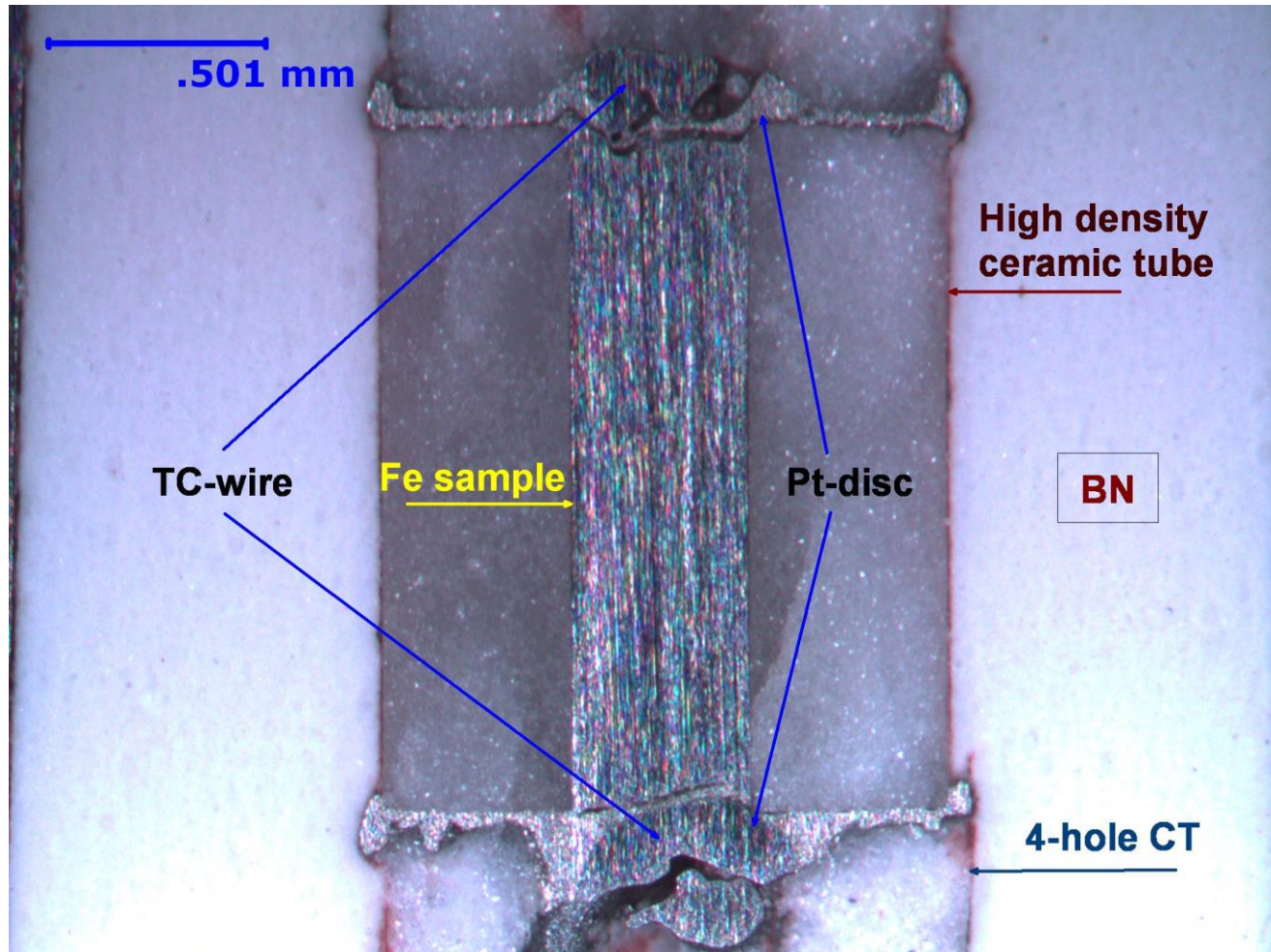





# Fe-14 (Pt-disc, 6GPa, $1289 \pm 10$ °C (data exists))

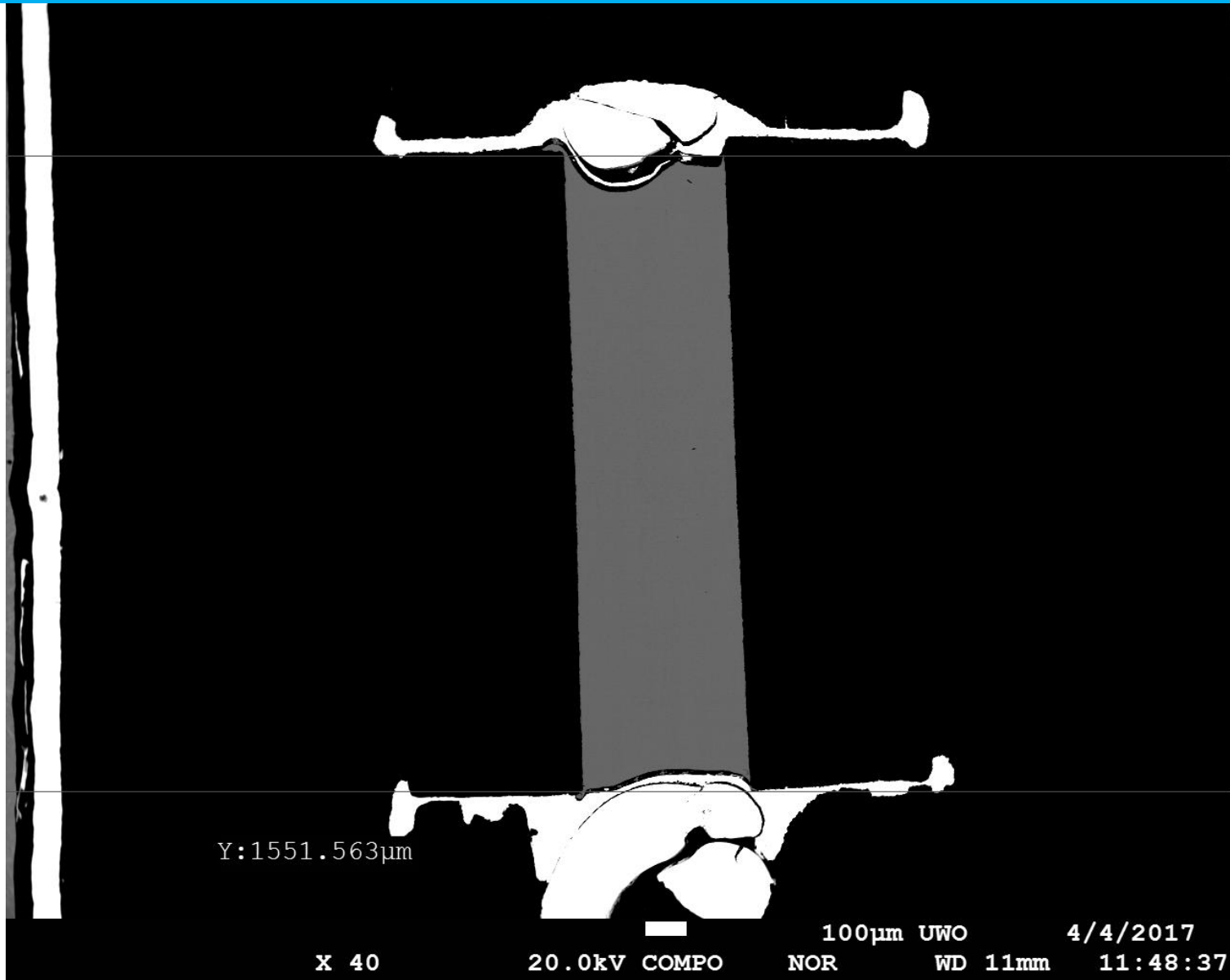

# Fe-6 (W-disc, 3GPa, $1768 \pm 10$ °C ) –data exists

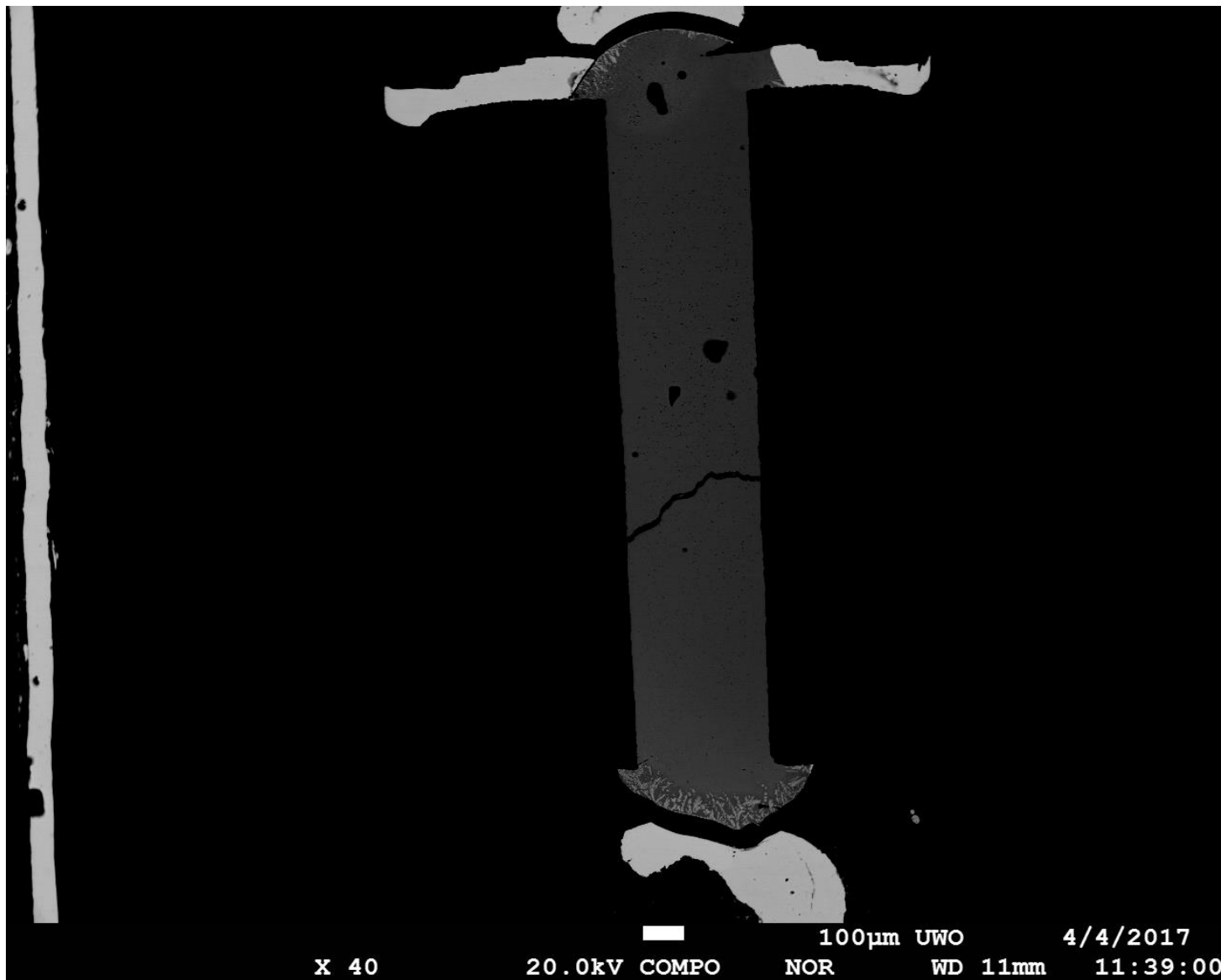

# Fe-9 (Pt-disc, 6GPa, $1670 \pm 20$ °C (controlled heating))

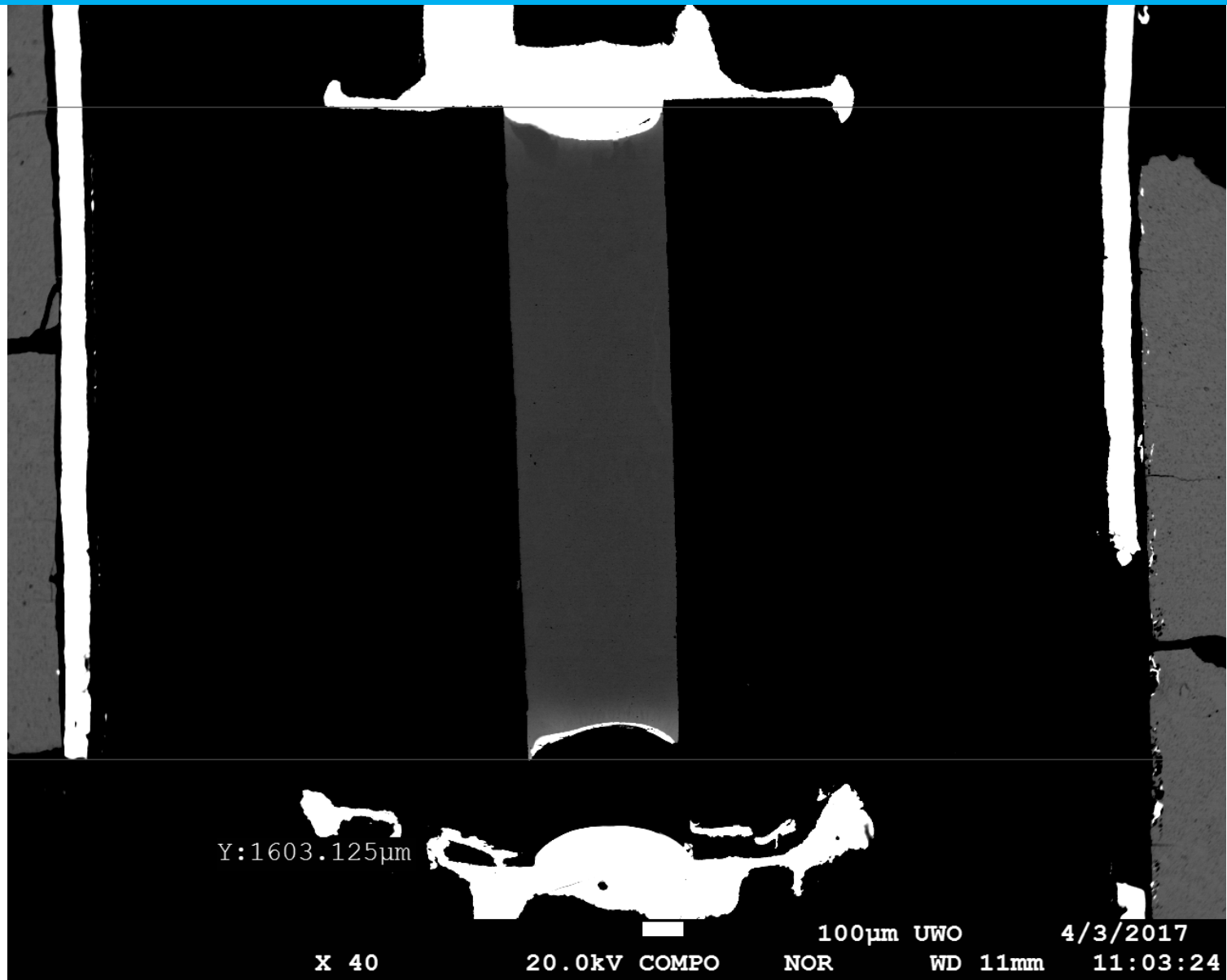



# Fe-7 (W-disc, 3GPa, $1829 \pm 10$ °C (data exists))

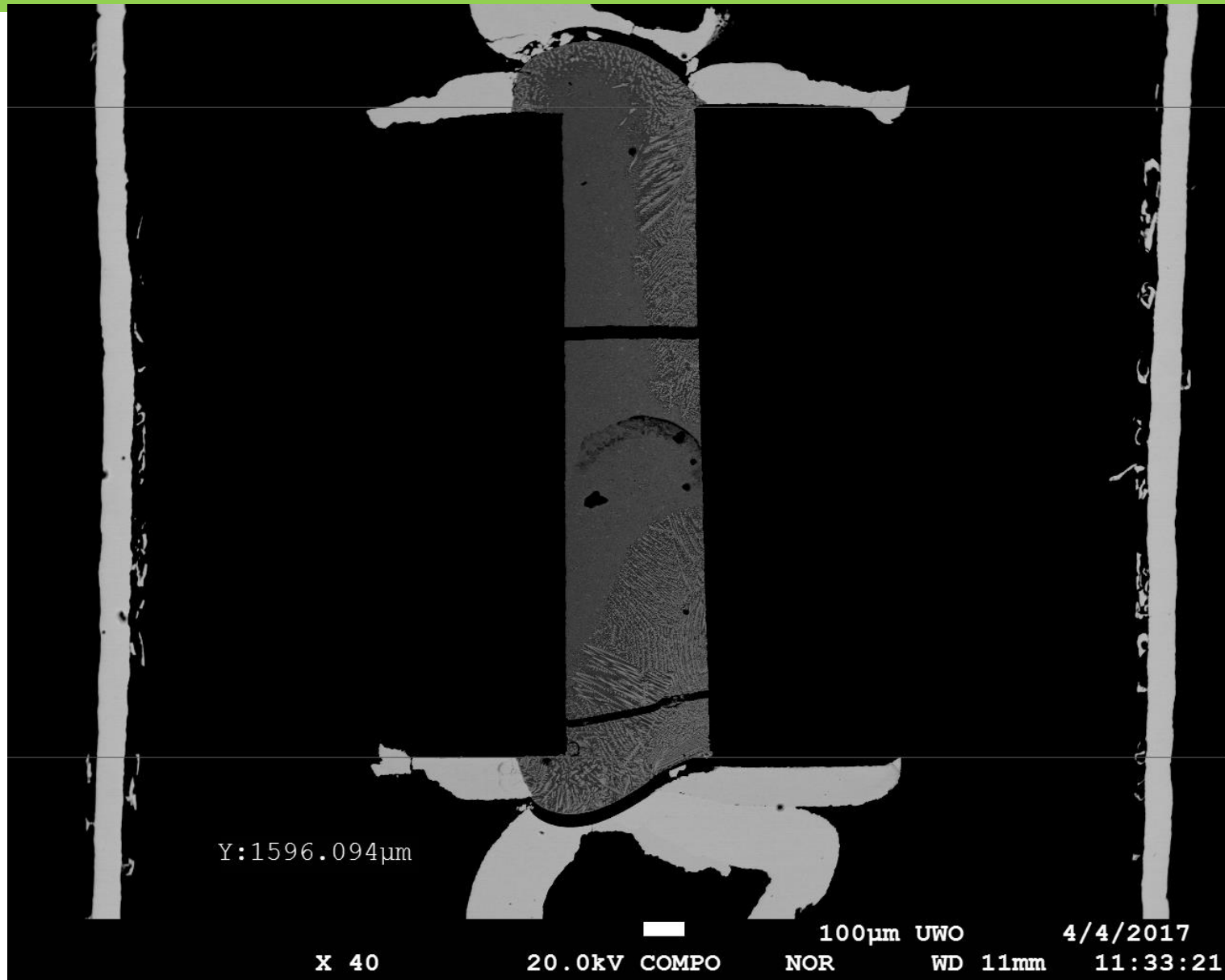

# Fe-10 (Pt-disc, 6GPa, $1750 \pm 40$ °C (increased error because of experimental uncertainty))

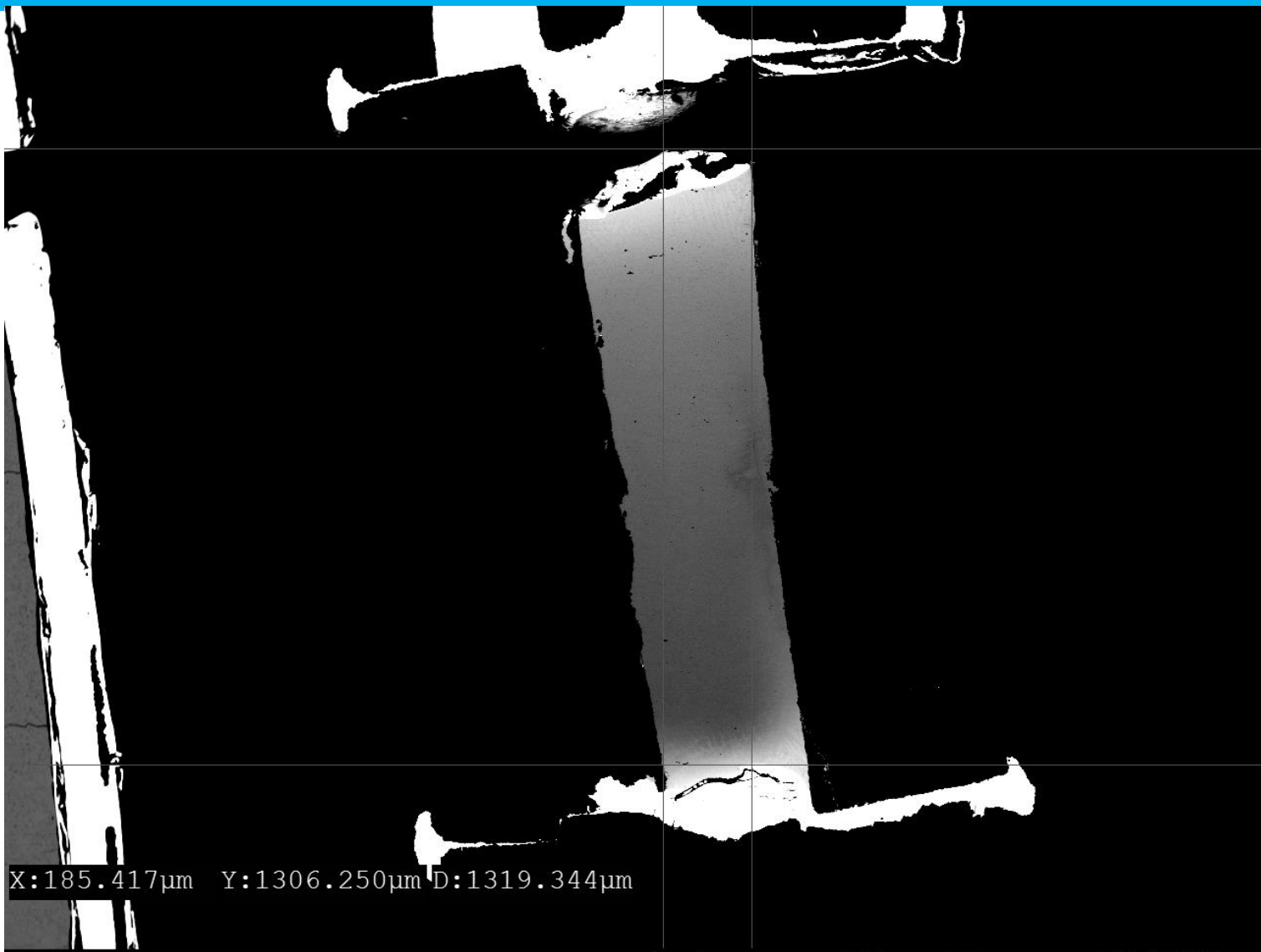

X:185.417µm Y:1306.250µm D:1319.344µm

X 45

20.0kV COMPO

NOR

100µm UWO

WD 11mm

4/3/2017

11:19:34



# Fe-11 (Pt-disc, 6GPa, $1850 \pm 40$ °C (increased error because of experimental uncertainty))

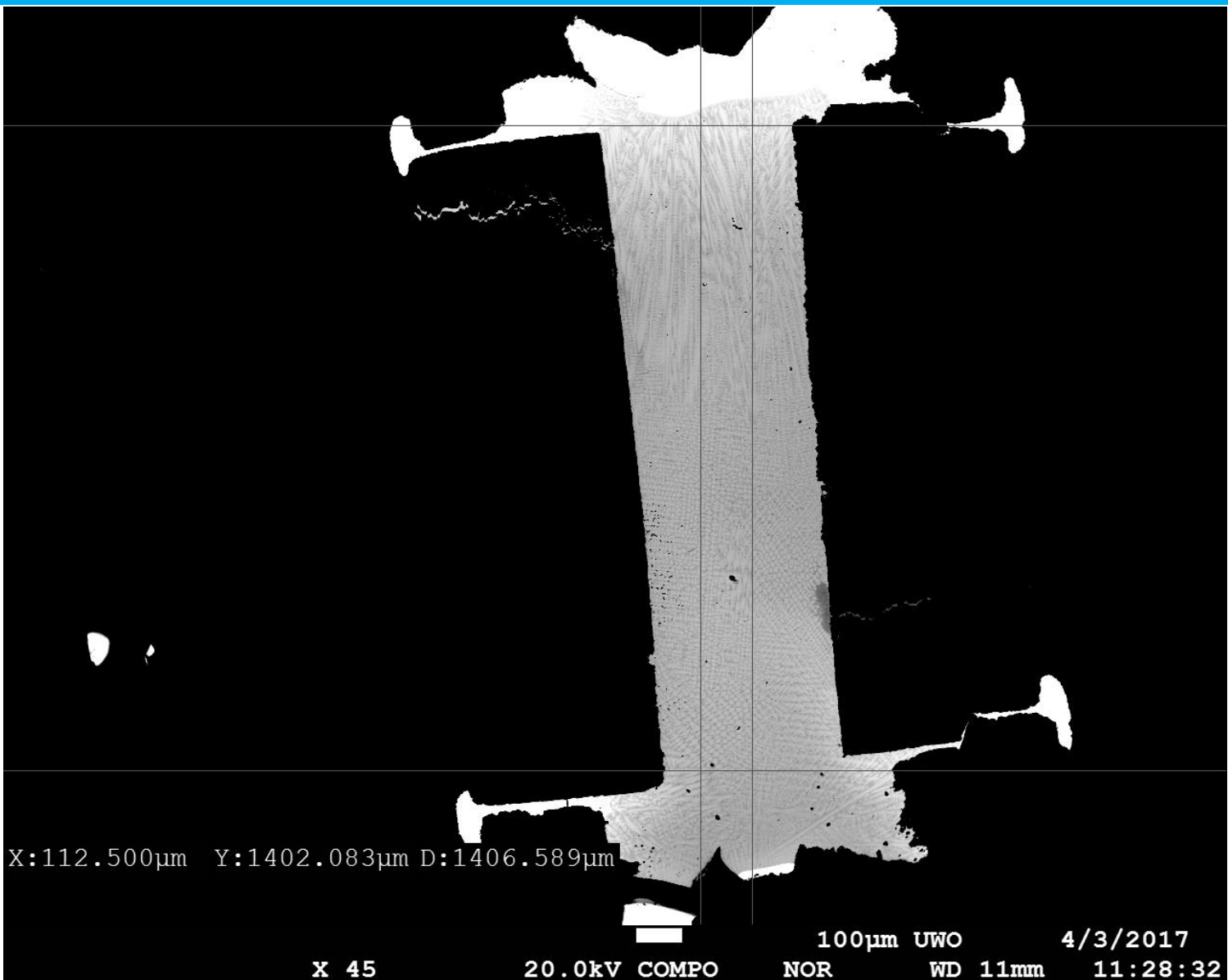



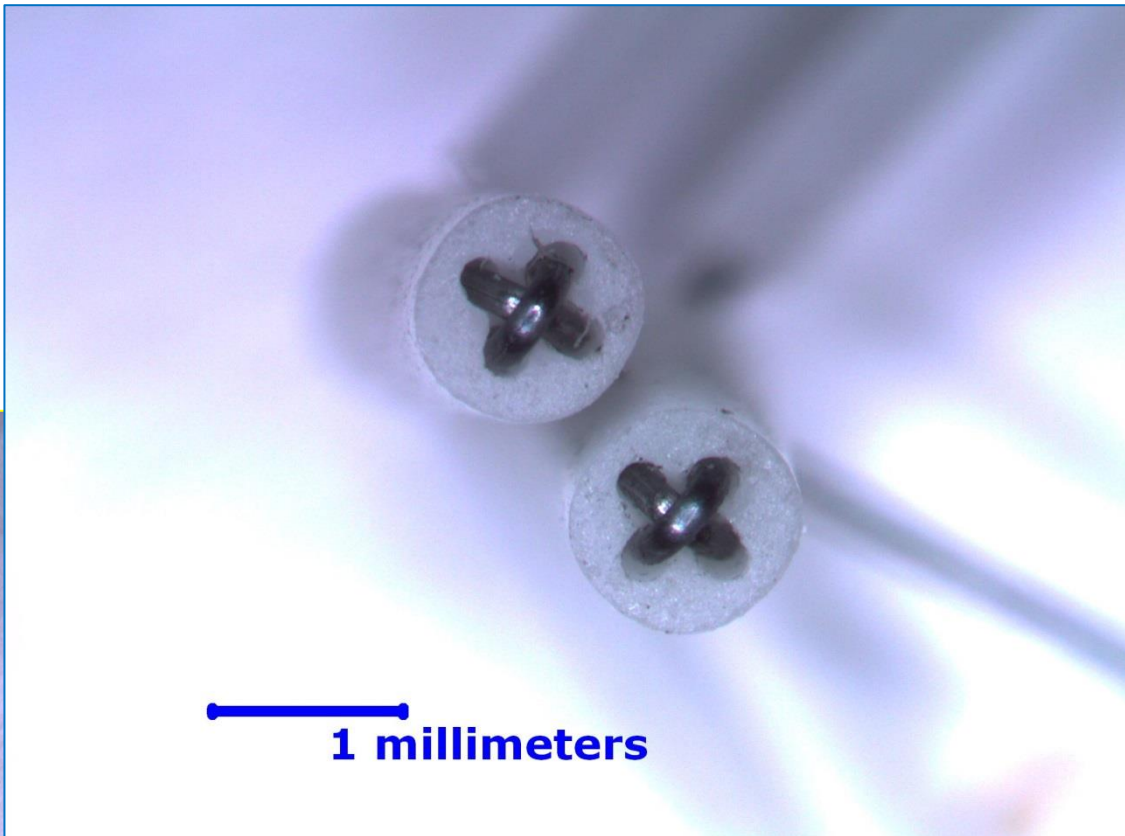
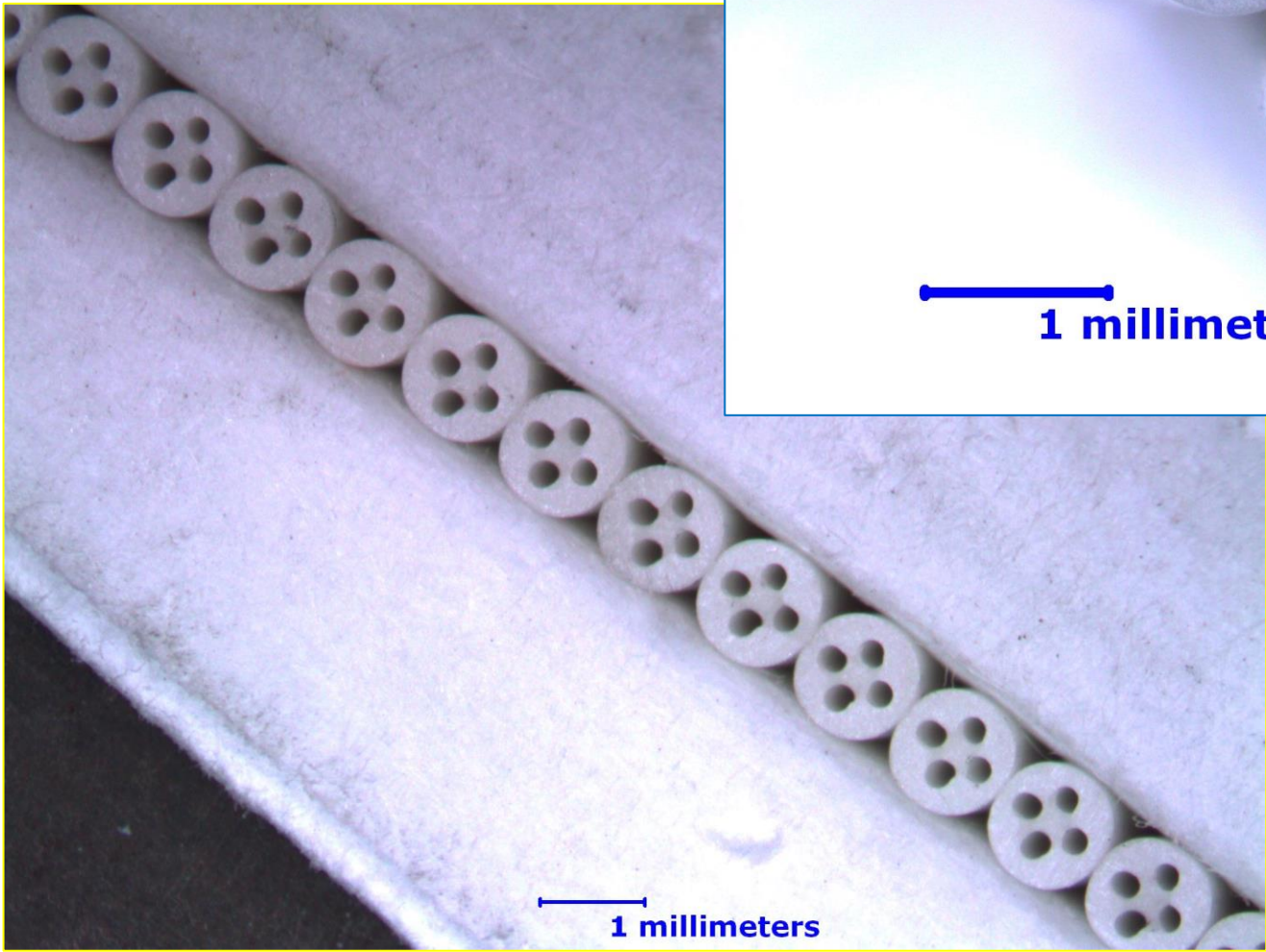

# Results

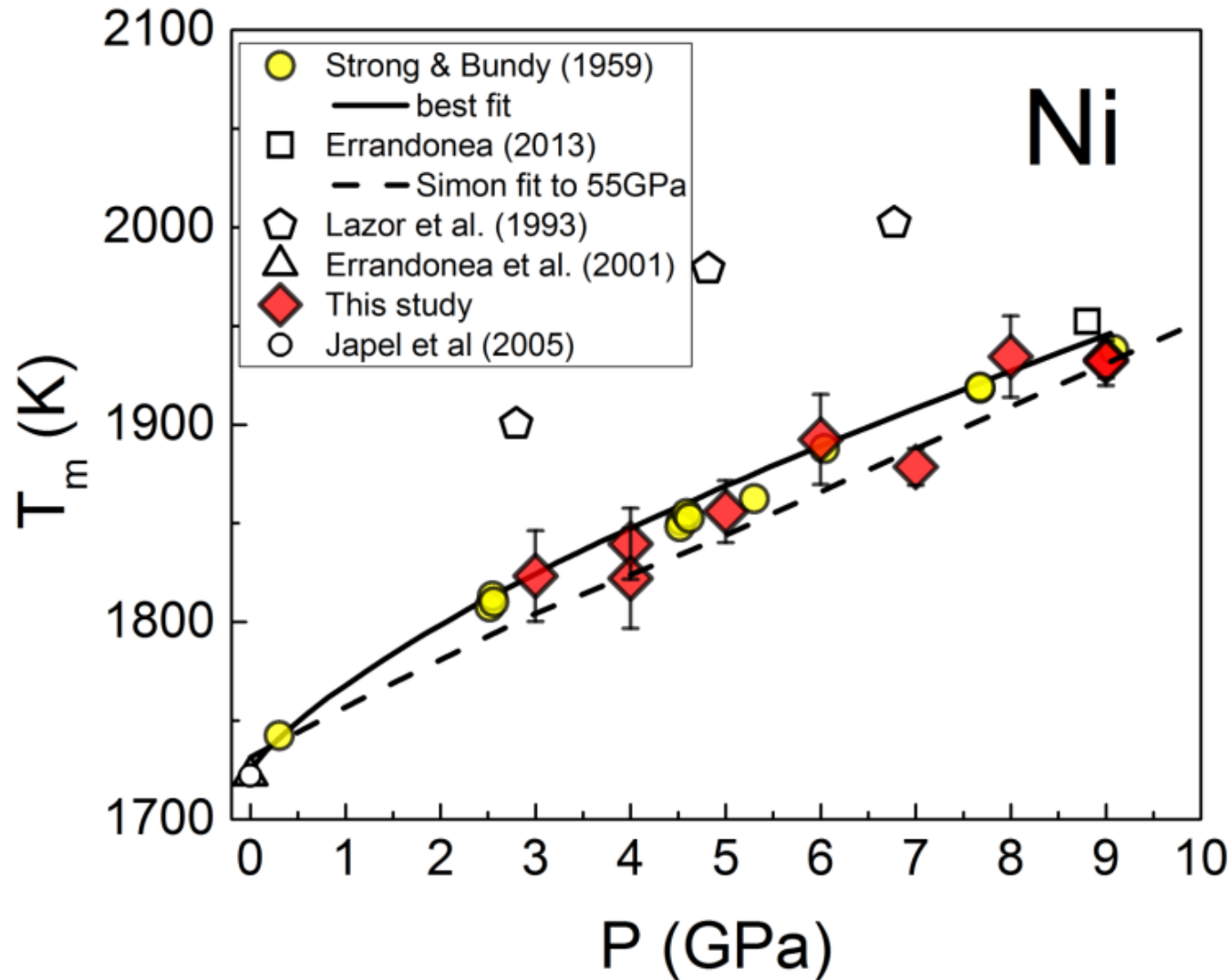

Melting temperatures of Ni obtained in this study compared with earlier studies in large volume press (yellow circles) and diamond anvil cells (other symbols)

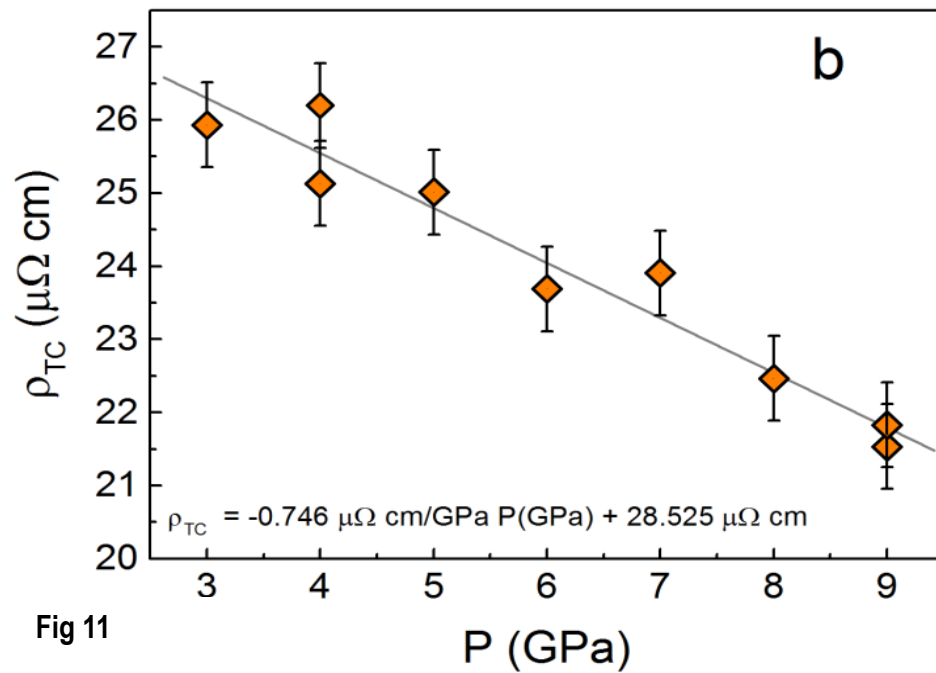
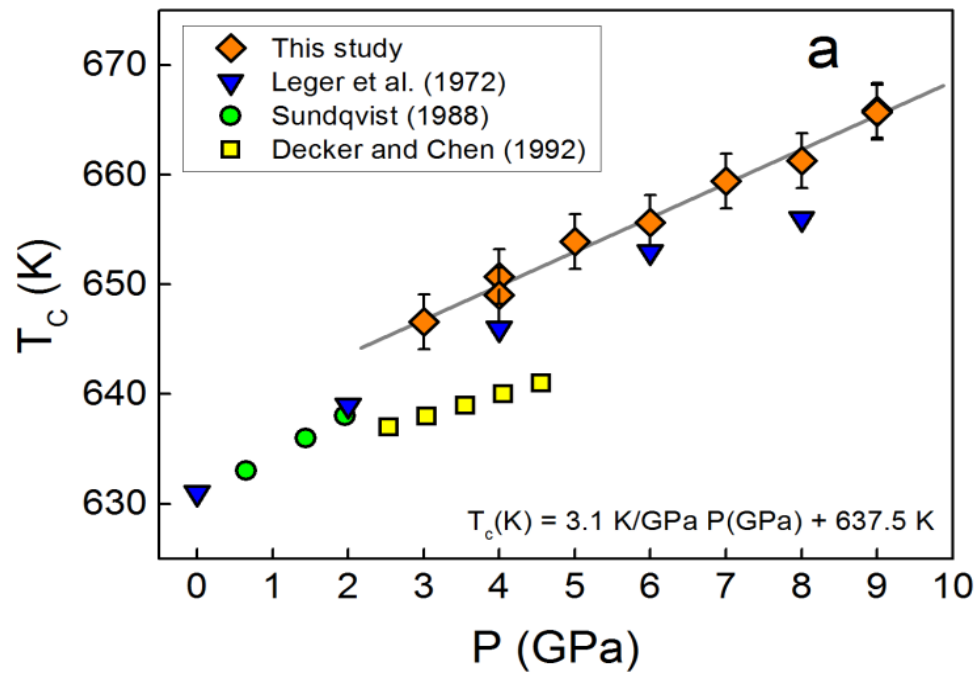

Fig 11

From Mott's formula for electrical conductivity [e.g. Mott, 1972; Shimoji, 1977; Mott, 1980] which is the basis for the Kubo-Greenwood expression used to calculate resistivity of transition metals [e.g. deKoker et al, 2012; Pozzo et al, 2012;13;14], the electrical resistivity of liquid metals is inversely proportional to the Fermi surface size and the mean free path of conduction electrons. Notably, in its unmodified form, the expression below is best applicable to simple liquid metals; however it can also be applied to complex liquids (i.e. molten transition metals) [Mott, 1980]:

$$\sigma_e = S_F |e|^2 l / 12\pi^3 \hbar \quad (1)$$

Here,  $\sigma_e$  is electrical conductivity,  $S_F$  is the area of the Fermi surface, and  $l$  is the electron mean free path which is defined as the product of the Fermi velocity,  $v_F$ , and the conduction electron relaxation time,  $\tau$ , where  $l = v_F \tau$  and  $\hbar$  is the modified Planck constant. The relaxation time varies with the density of states (DOS) at the Fermi level [Shimoji, 1977] and the combined scattering mechanisms operating at a specific P and T.

- Ni ( $[\text{Ar}] 4s^2 3d^8$ ) is a close electronic analogue of Fe ( $[\text{Ar}] 4s^2 3d^6$ )