



SiPM Signal Reconstruction  
for Background Tagging in  
SHiP



Anne Sophie Müller

[anne.mueller1@email.uni-freiburg.de](mailto:anne.mueller1@email.uni-freiburg.de)

Physikalisches Institut, Albert-Ludwigs-Universität Freiburg

08.05.2026

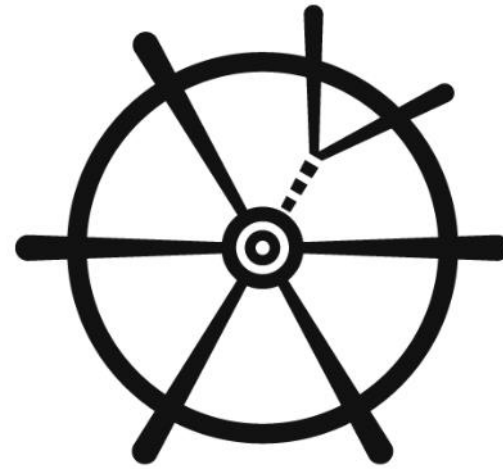

**SHiP**

*Search for Hidden Particles*

# SHiP Experiment

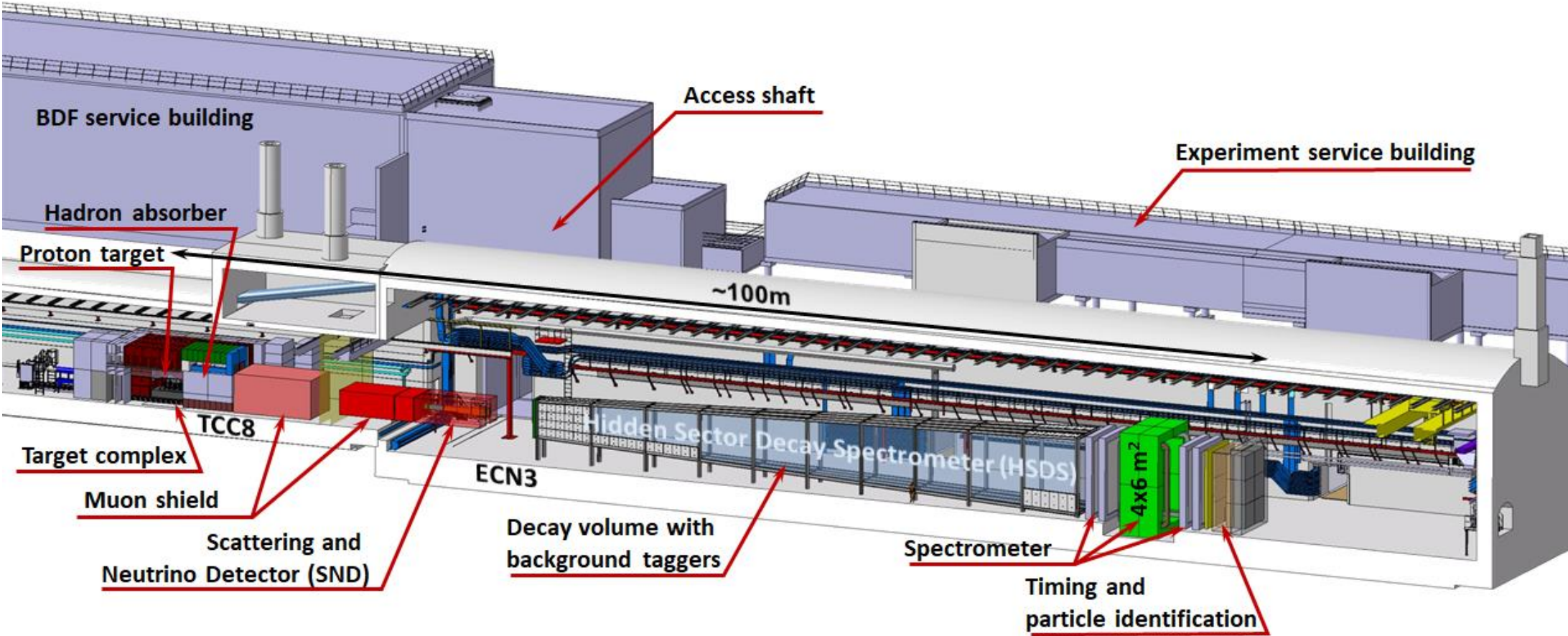

# SHiP Experiment

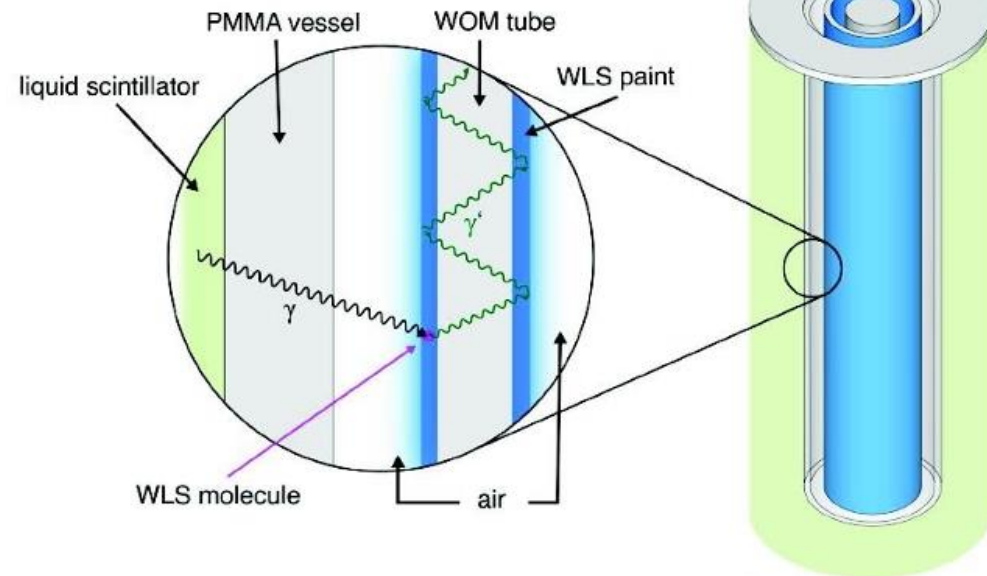
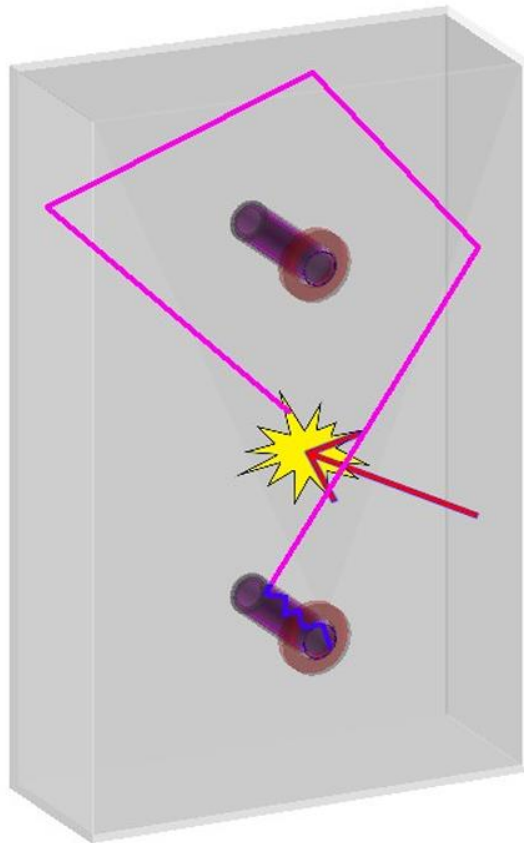

WOM tube inside PMMA vessel surrounded by liquid scintillator

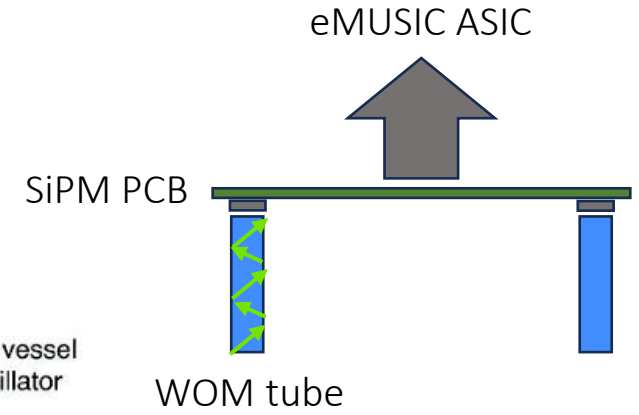

# Motivation



**Guiding question:**

How many photons were recorded in the sensors for a given waveform?

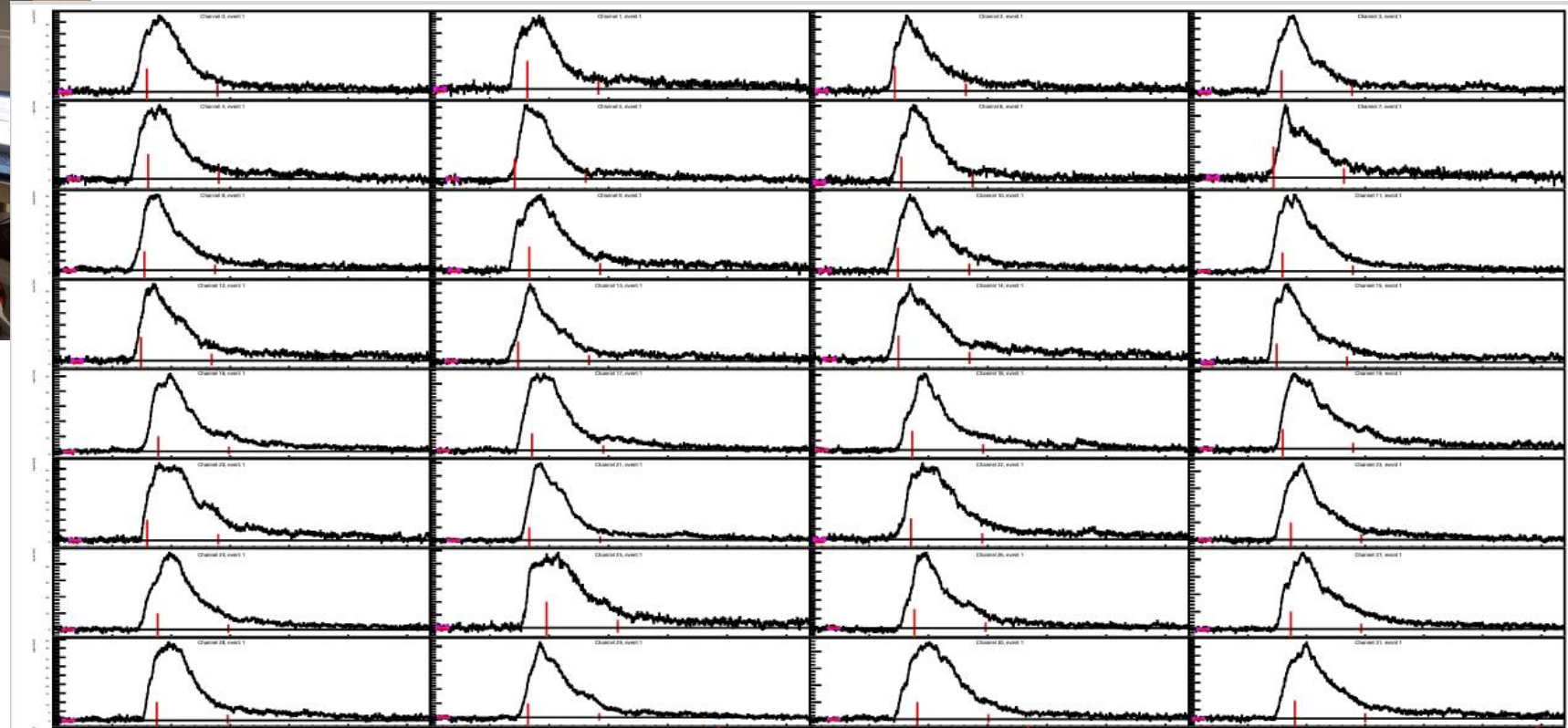

# Motivation



**Guiding question:**  
How many photons were recorded in the sensors for a given waveform?

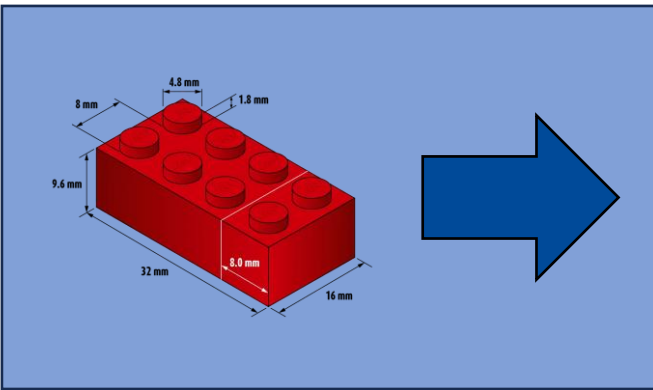
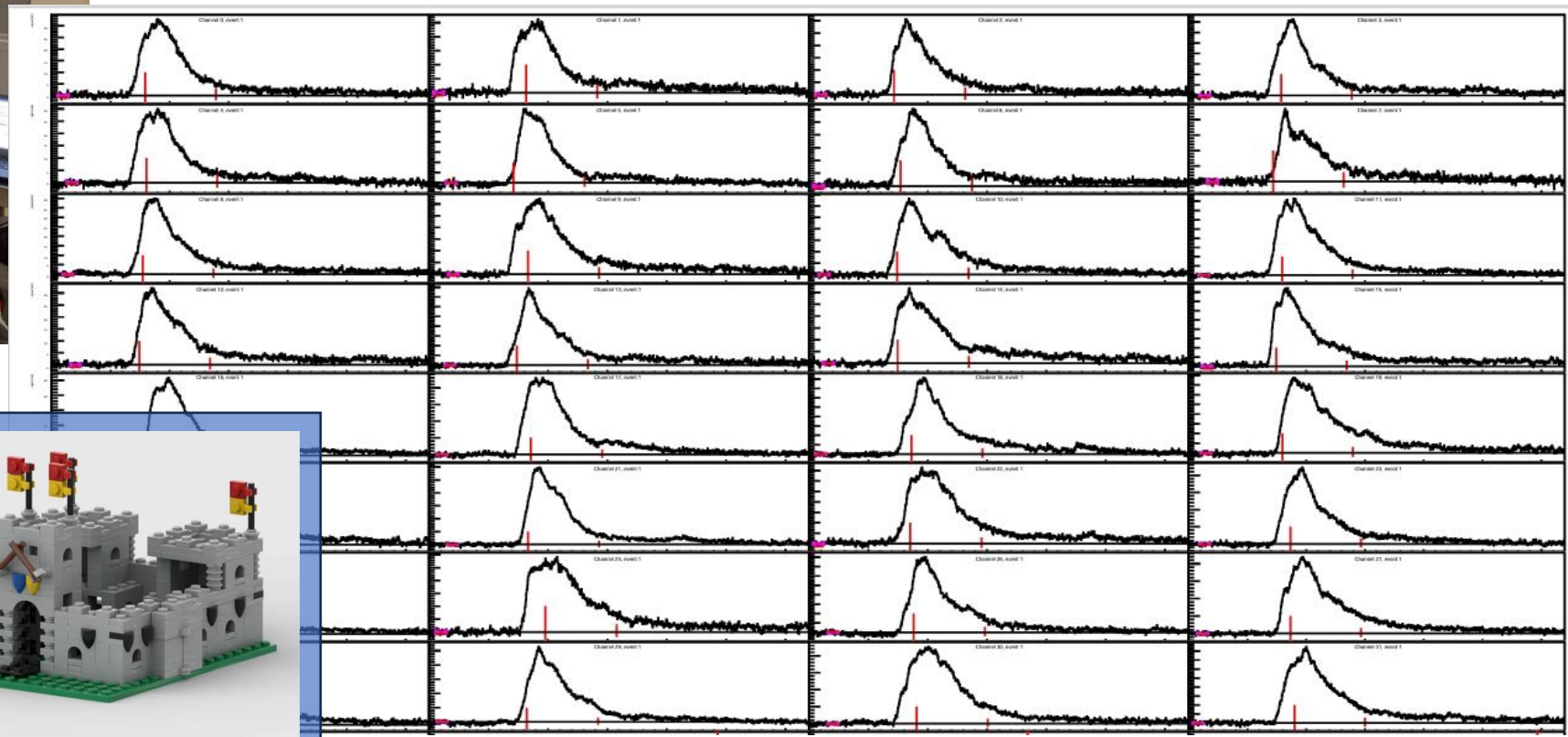

Characterise the detector response to single photons

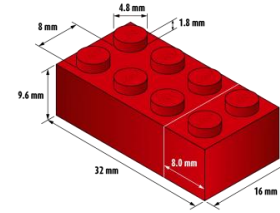

Prove the working principle for signals with low photon multiplicities

Develop automated template-based reconstruction method for larger waveforms

Find correlations between number of photons in a signal and waveform characteristics

Characterise the detector response to single photons

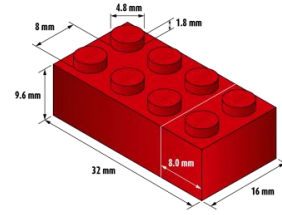

Prove the working principle for signals with low photon multiplicities

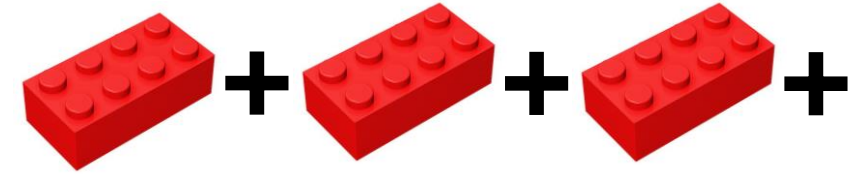

Develop automated template-based reconstruction method for larger waveforms

Find correlations between number of photons in a signal and waveform characteristics

□ Characterise the detector response to single photons

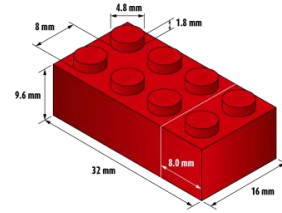

□ Prove the working principle for signals with low photon multiplicities

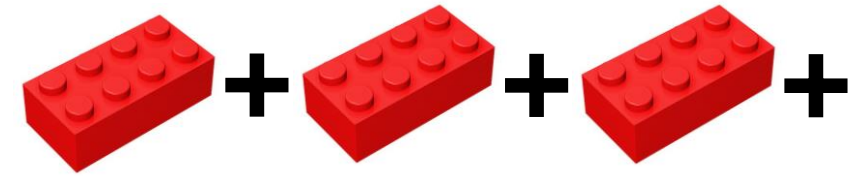

□ Develop automated template-based reconstruction method for larger waveforms

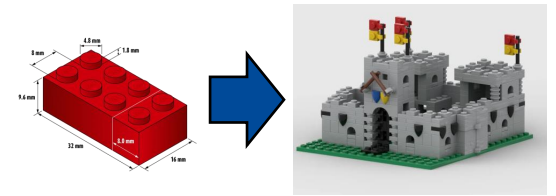

□ Find correlations between number of photons in a signal and waveform characteristics

❑ Characterise the detector response to single photons

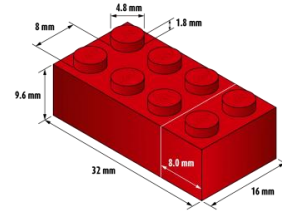

❑ Prove the working principle for signals with low photon multiplicities

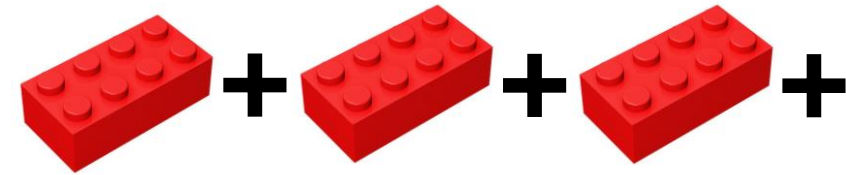

❑ Develop automated template-based reconstruction method for larger waveforms

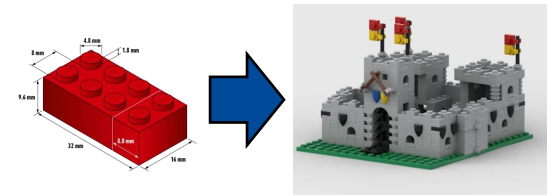

❑ Find correlations between number of photons in a signal and waveform characteristics

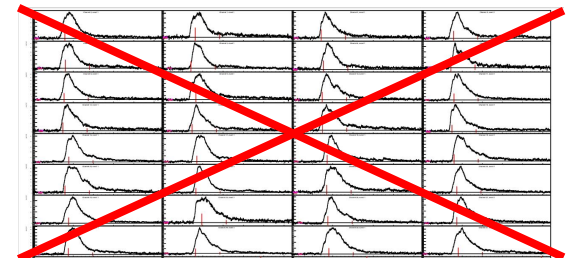

# Setup

SPAD

Multiplication

Absorption

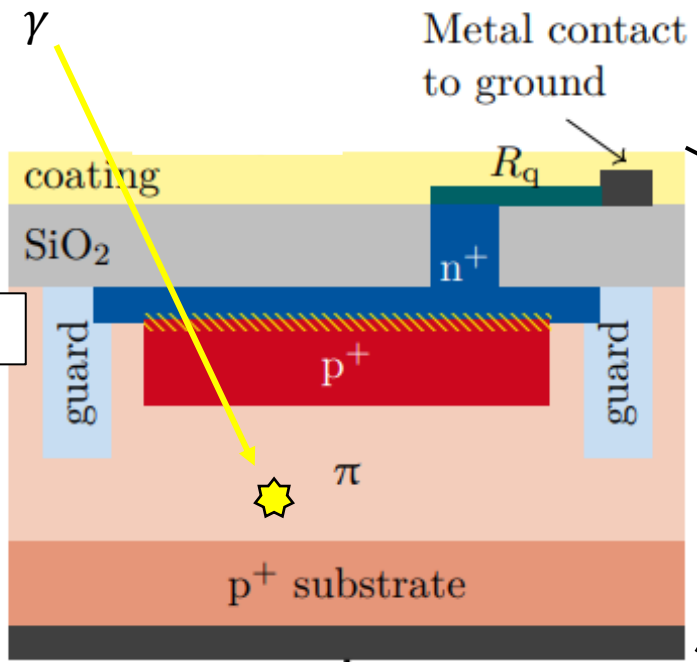

SiPM

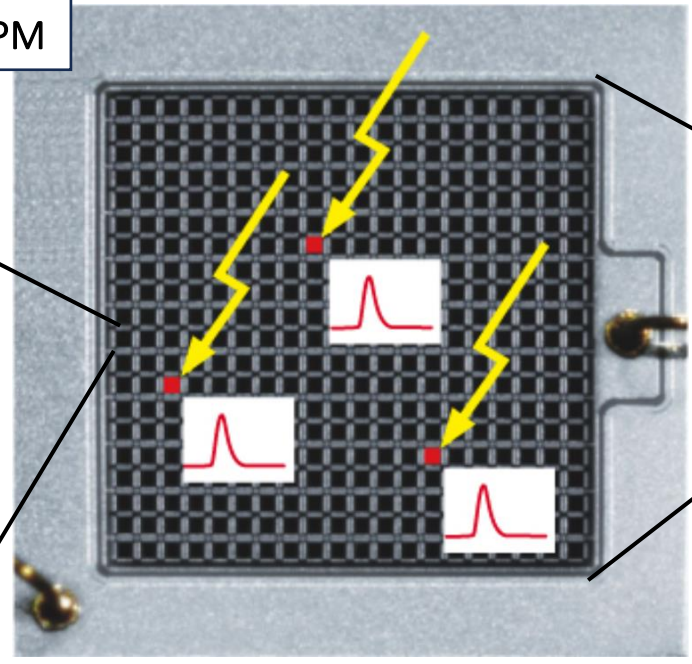

SiPM PCB

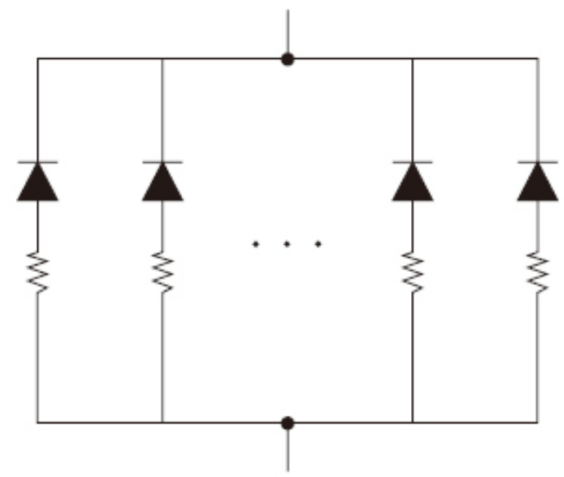
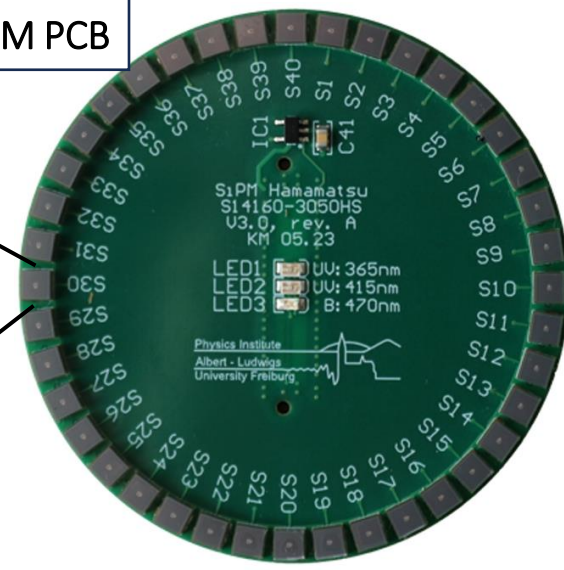

SiPM PCB

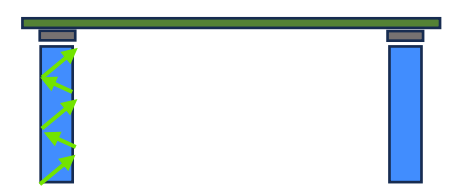

WOM tube

# Setup

SPAD

Multiplication

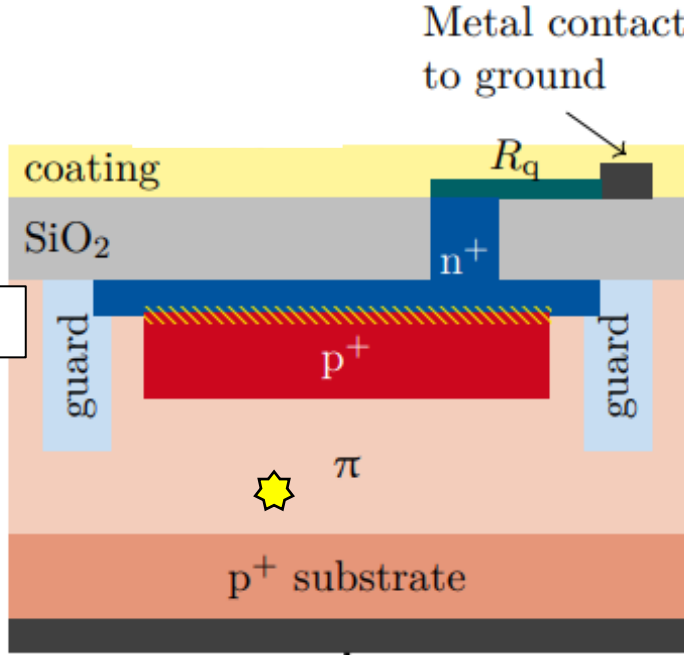

SiPM

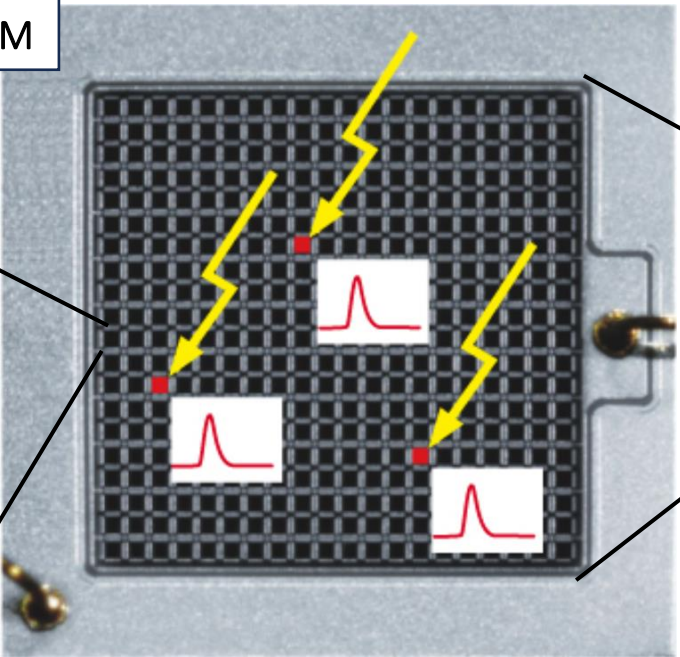

SiPM PCB

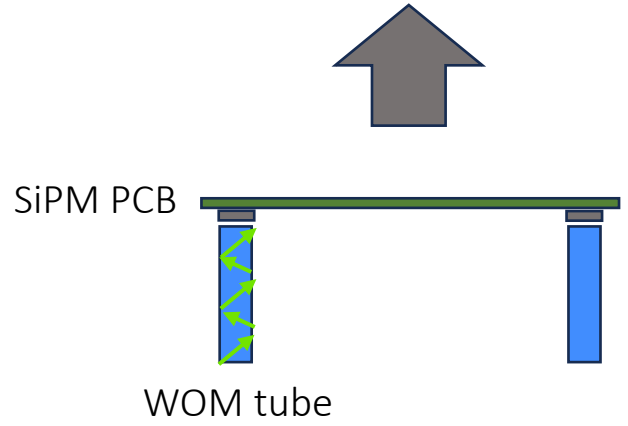
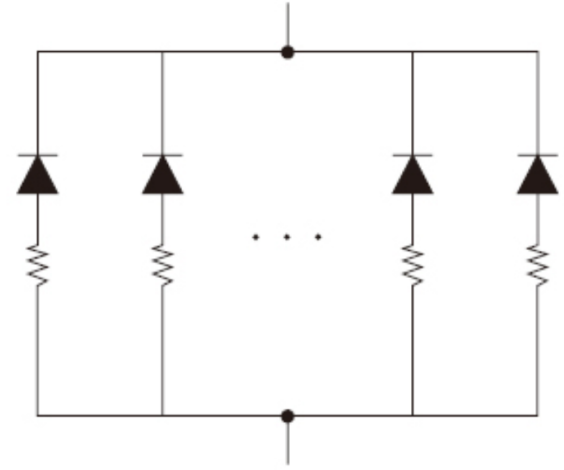
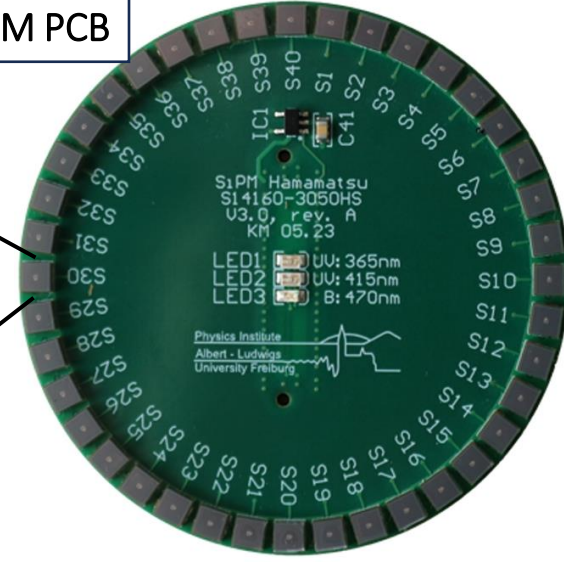

# Setup

- Dark Count Measurements with Hamamatsu-SiPM Board
- Light-tight setup
- Modulated noise from generator as random trigger

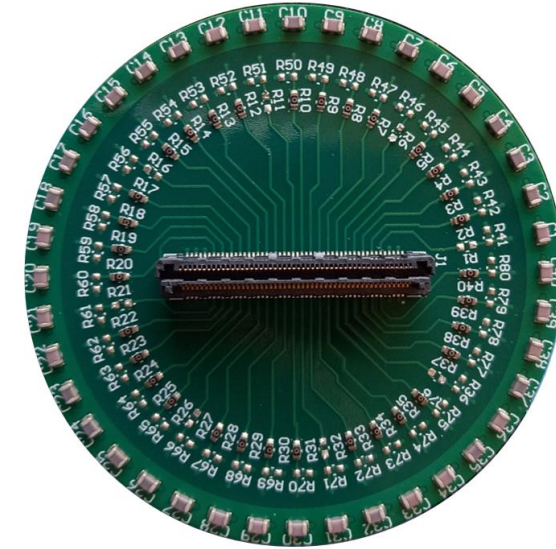
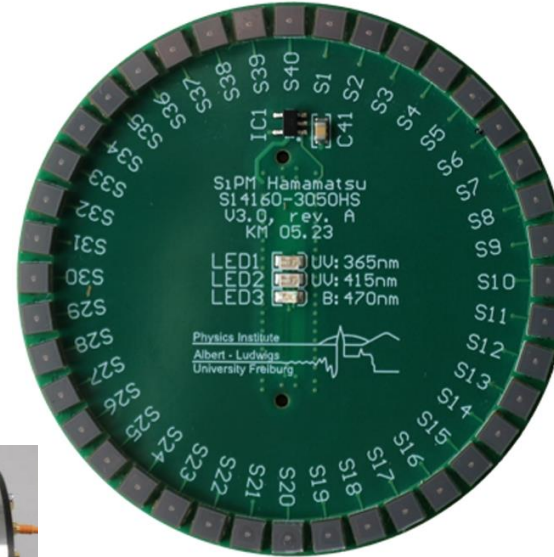
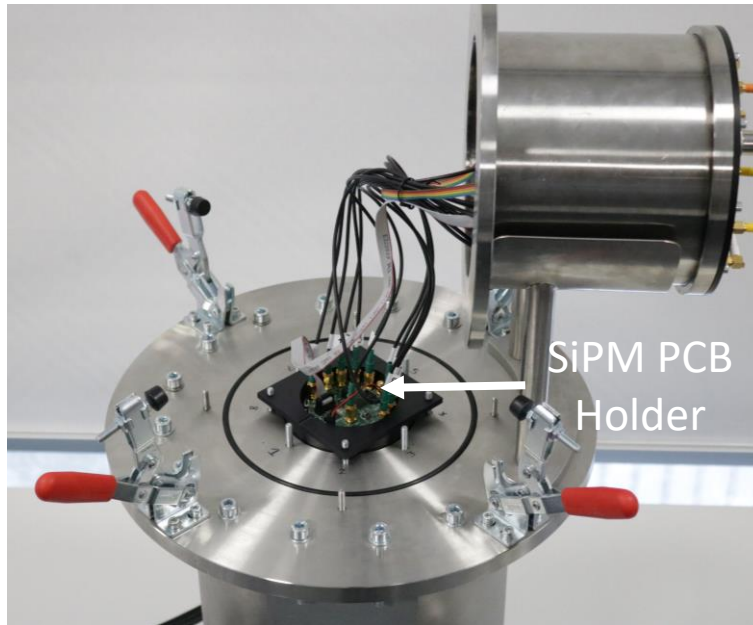
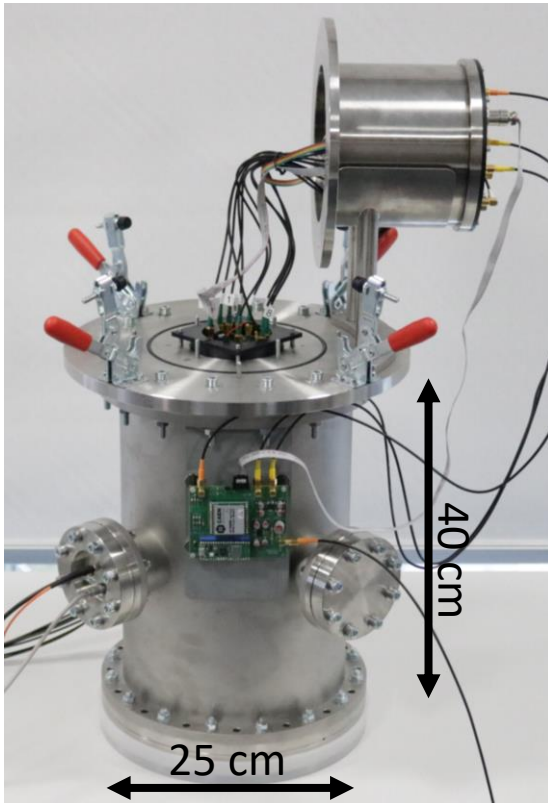

# Setup

- Dark Count Measurements with Hamamatsu-SiPM Board
- Light-tight setup
- Modulated noise from generator as random trigger

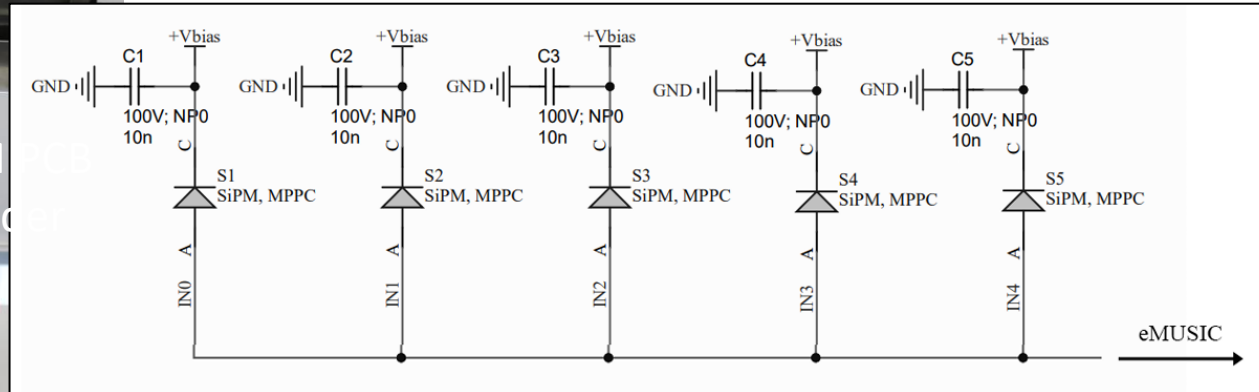
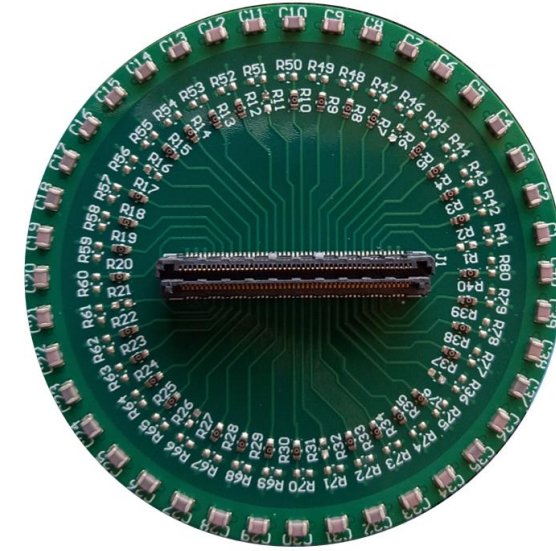
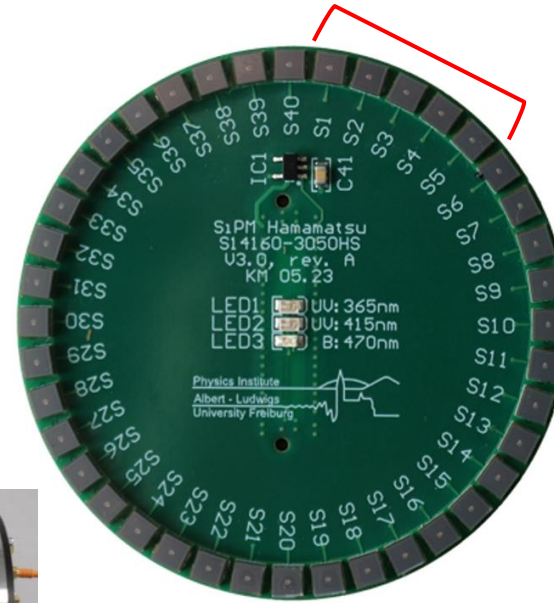
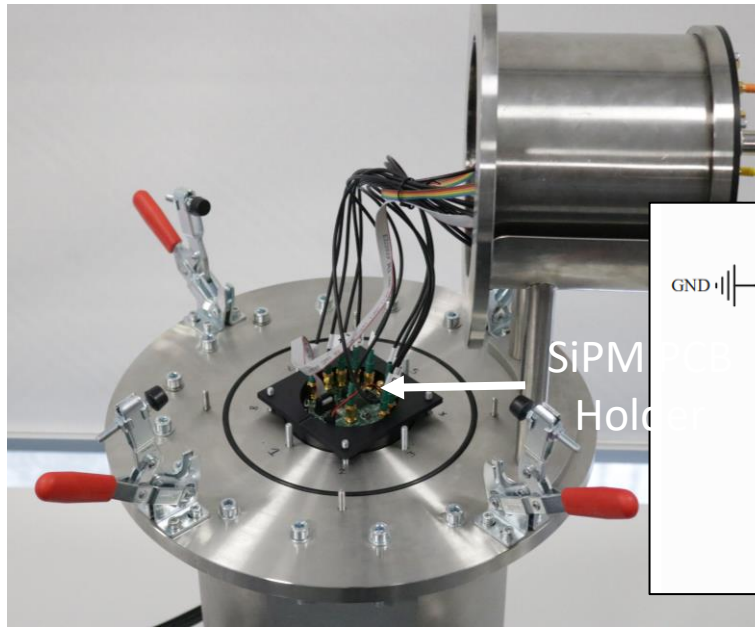
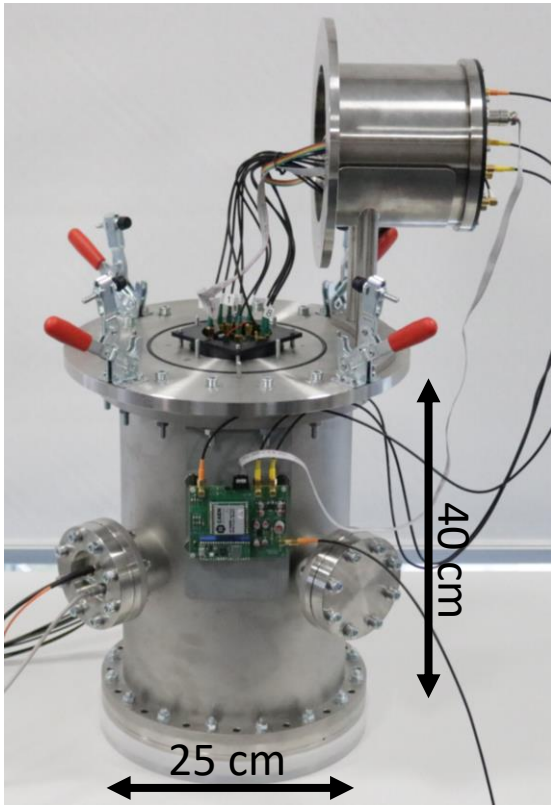

# Setup

SiPMs read out individually:

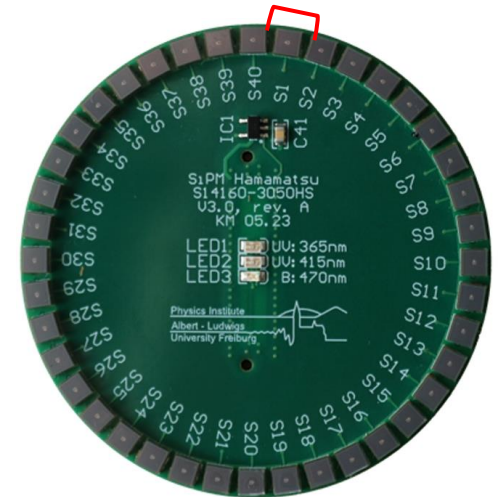
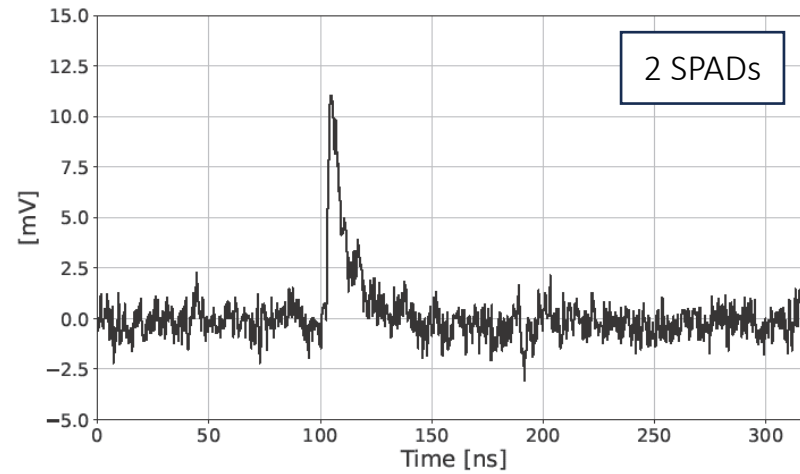
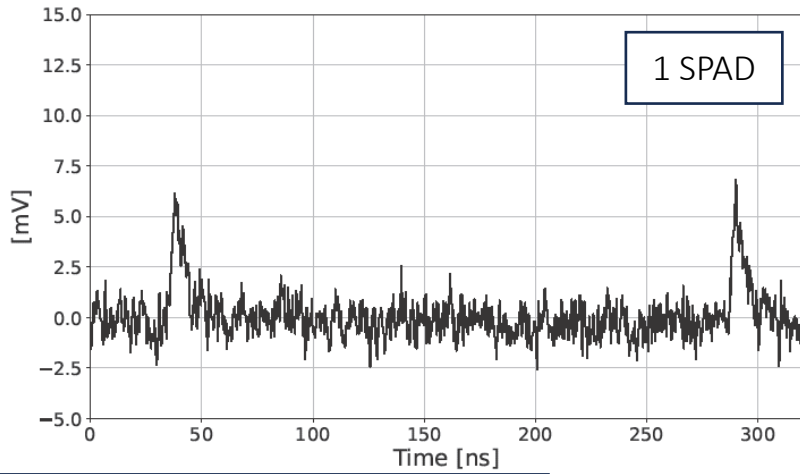

5SiPMs read out in parallel:

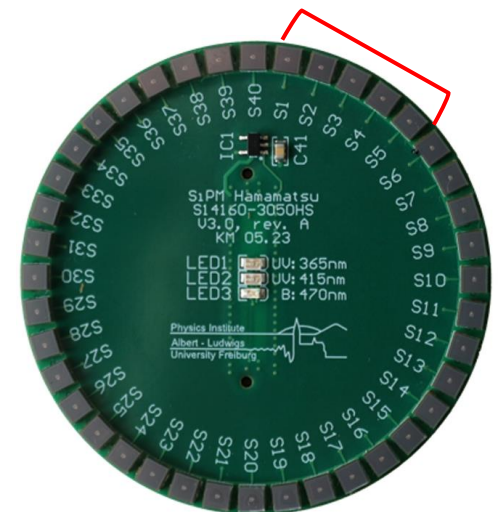
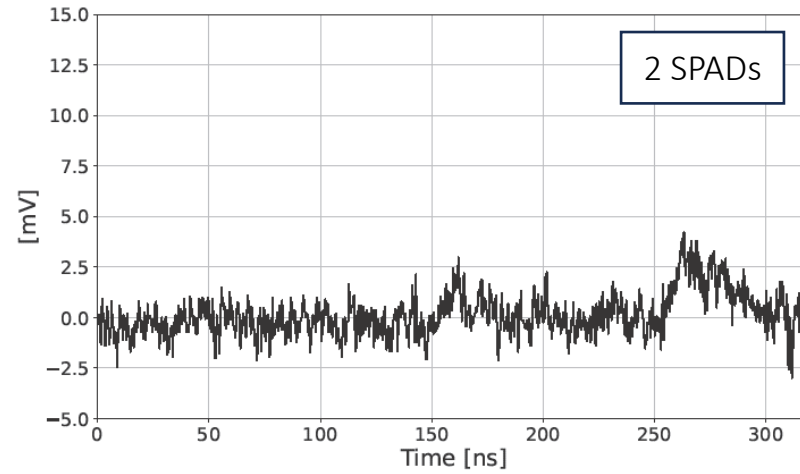
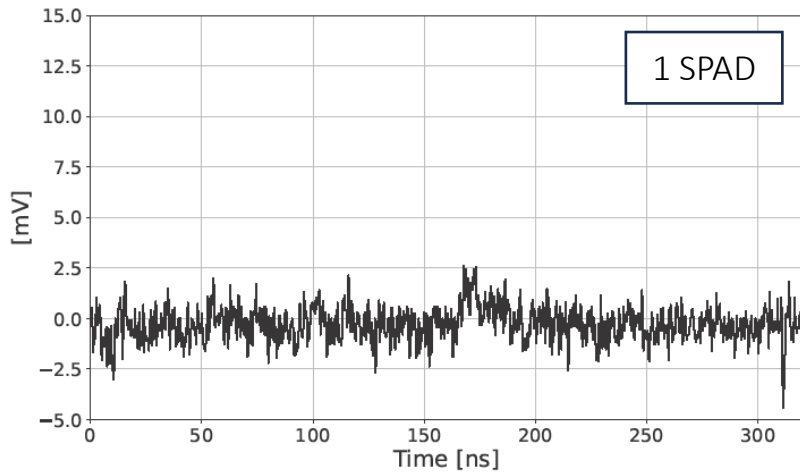

# Setup

SiPMs read out individually:

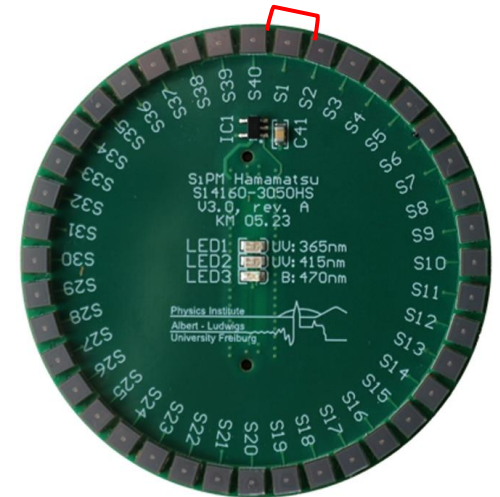
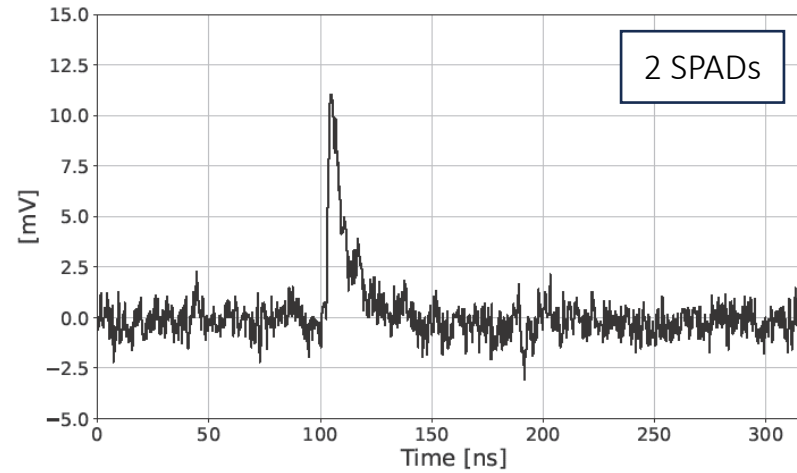
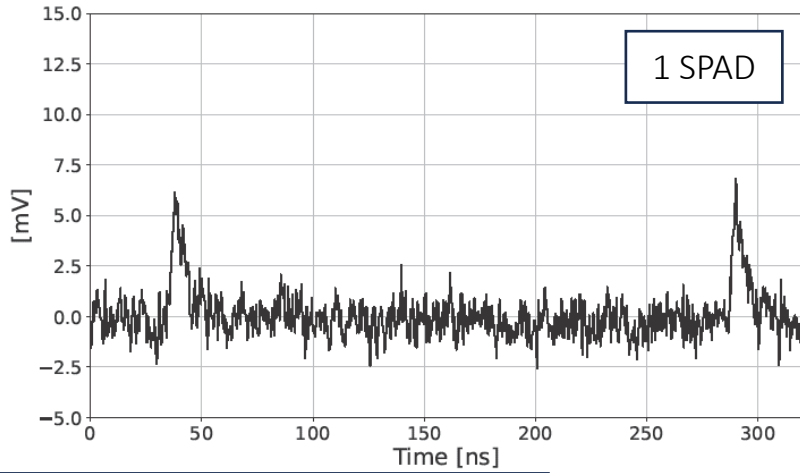

5SiPMs read out in parallel:

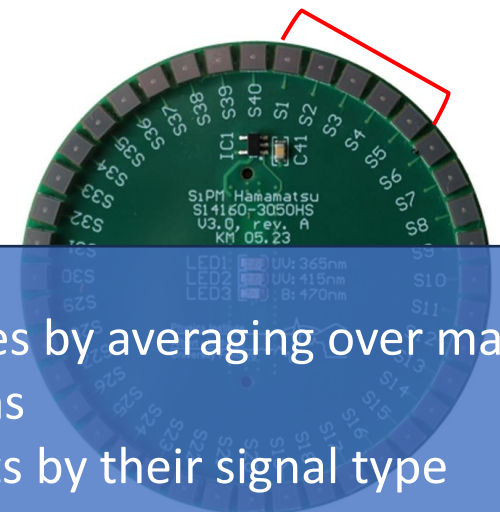
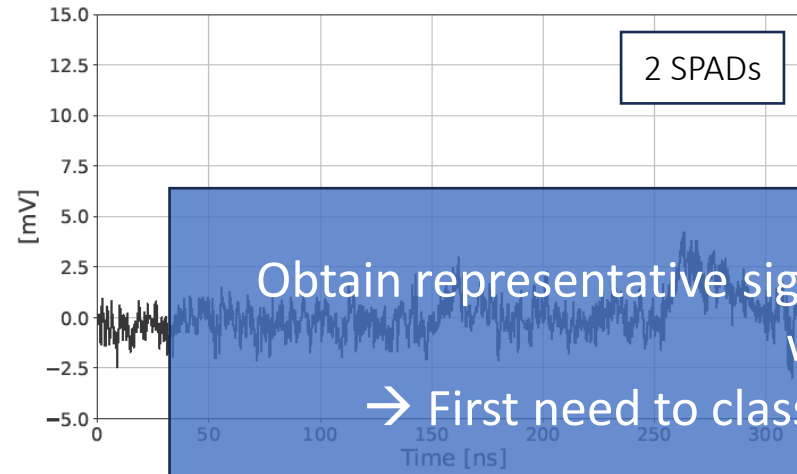
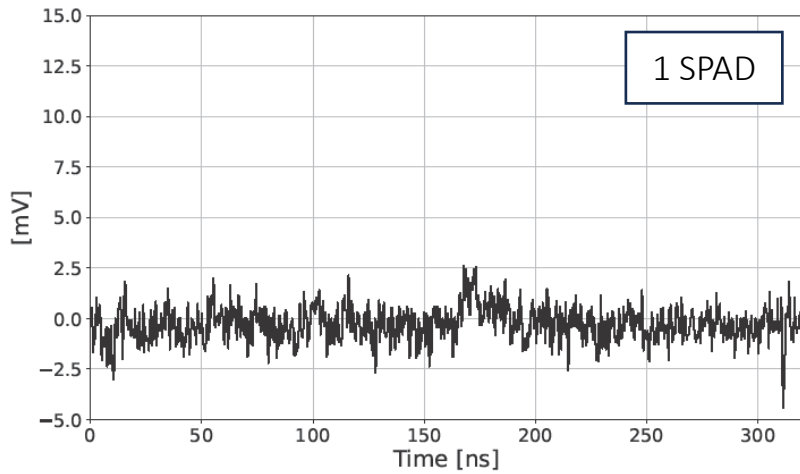

Obtain representative signal shapes by averaging over many waveforms

→ First need to classify events by their signal type

# Event characterisation - Amplitude

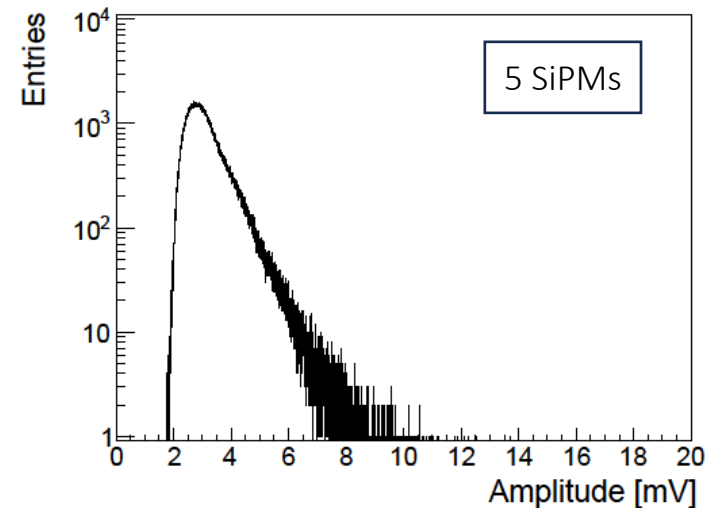
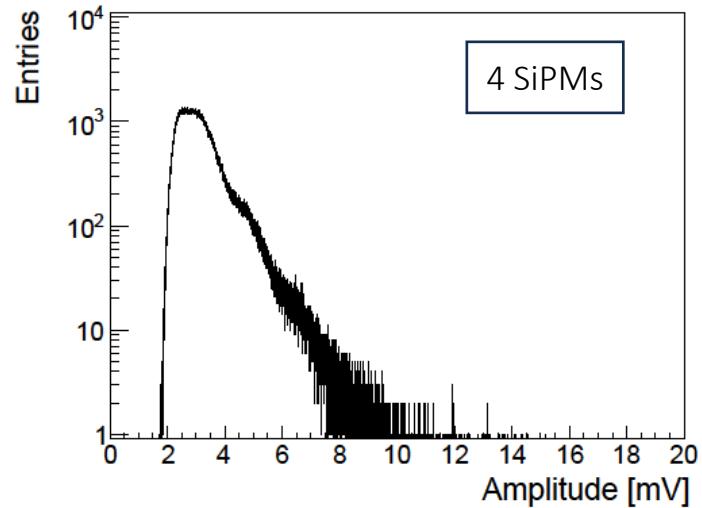
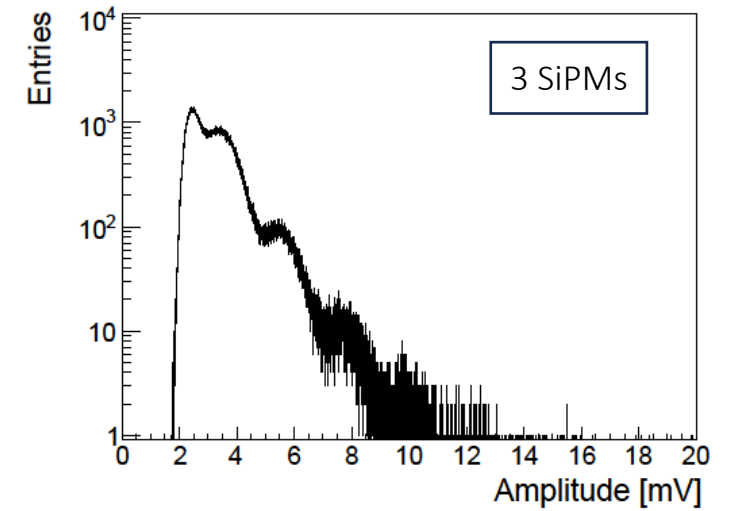
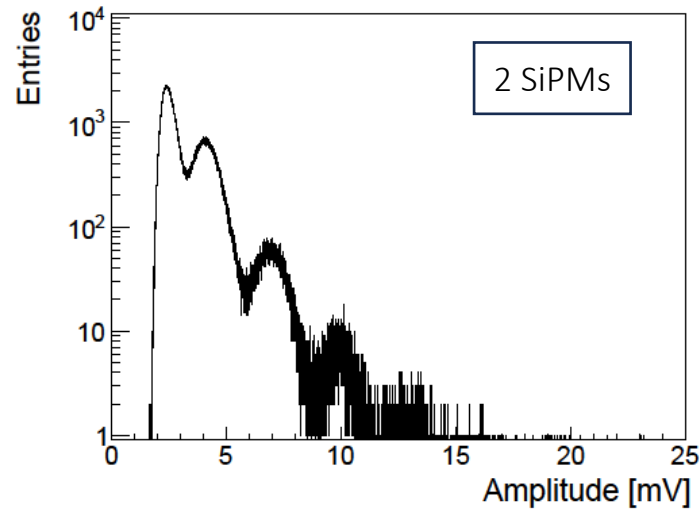
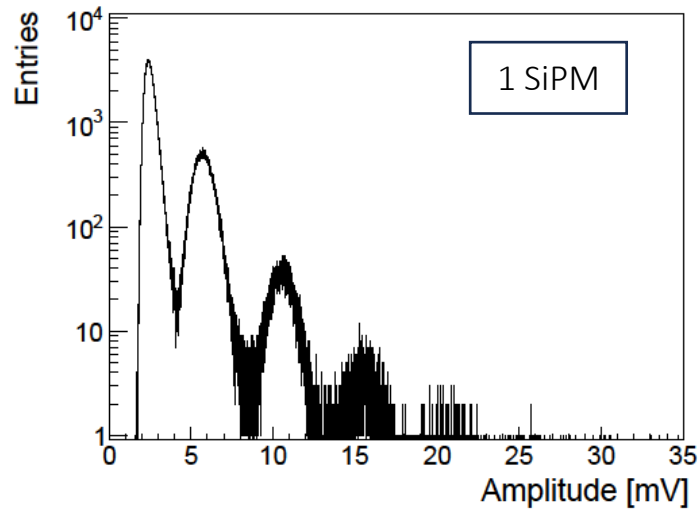

# Event characterisation - Amplitude

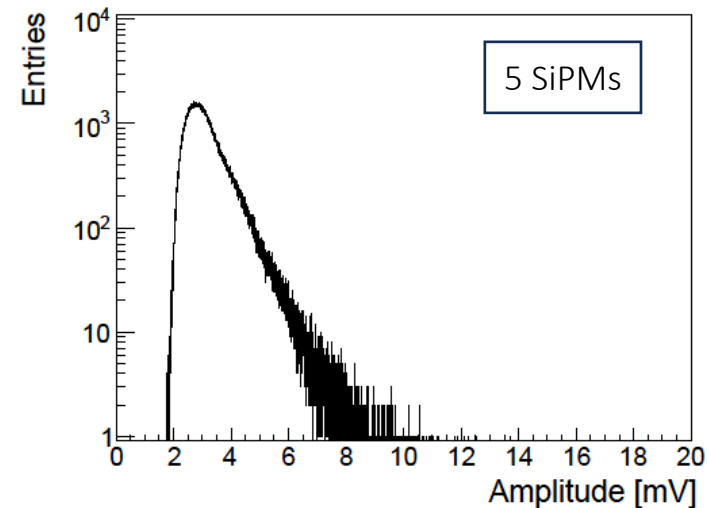
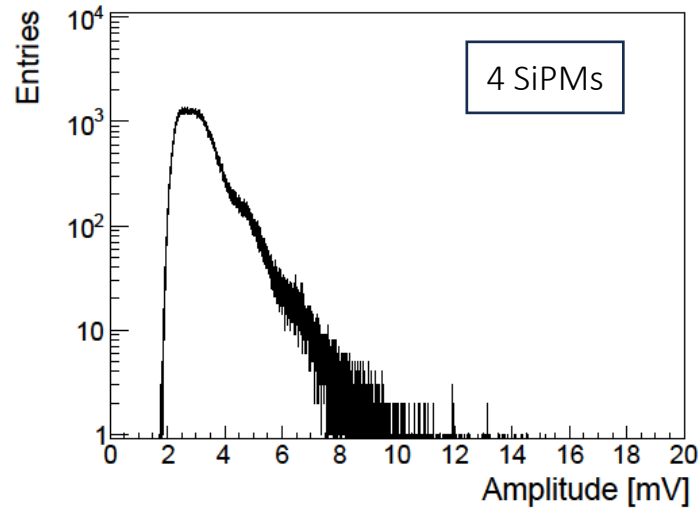
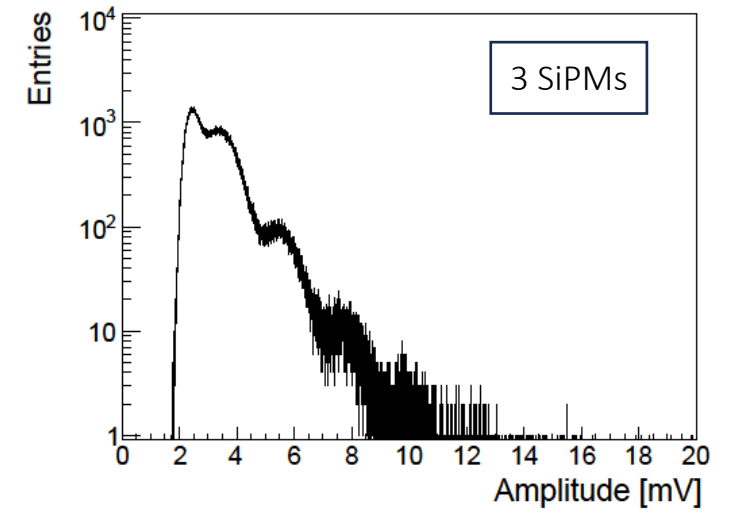
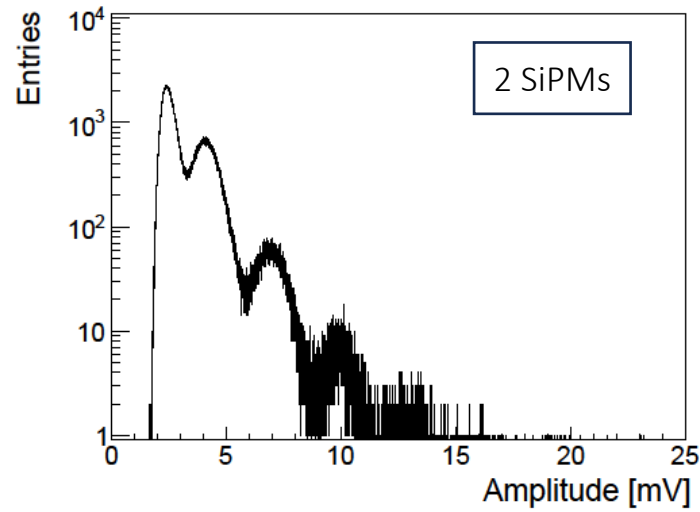
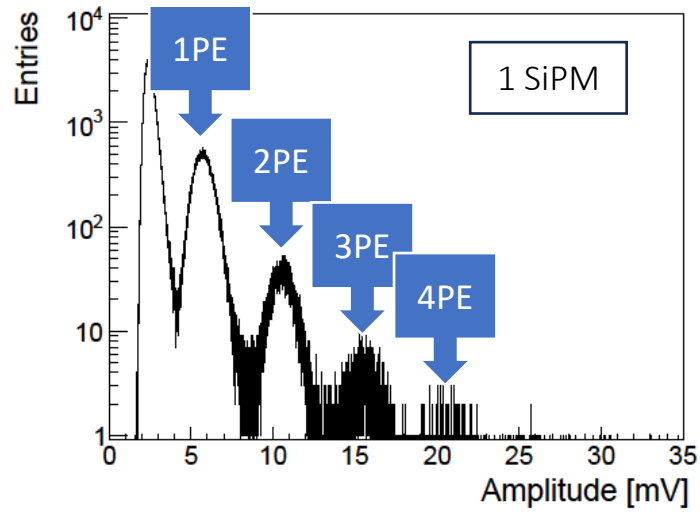

# Event characterisation - Integral

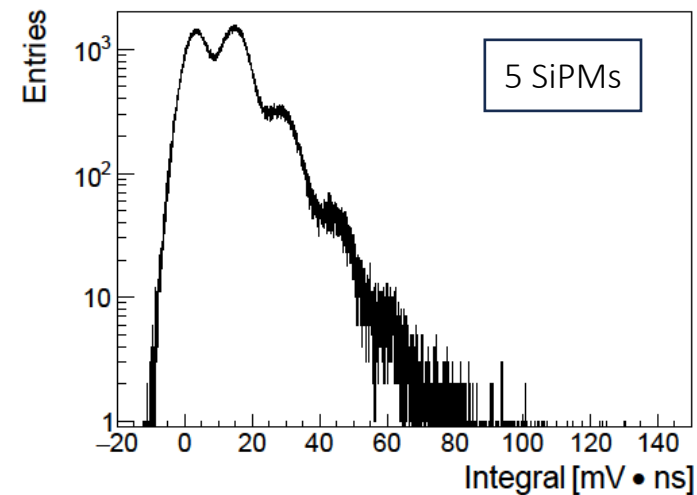
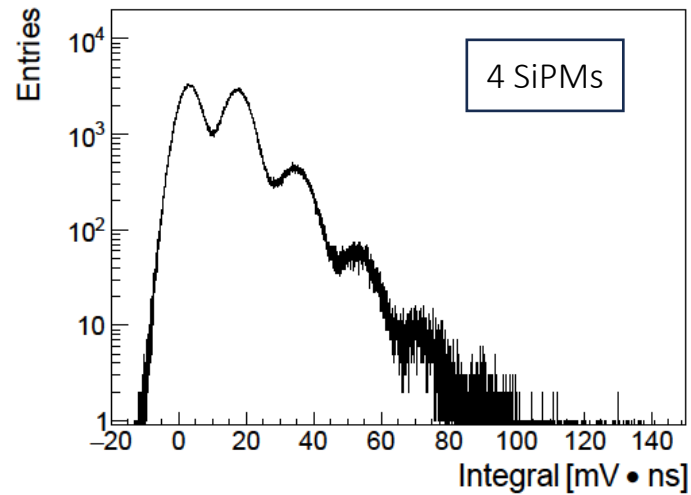
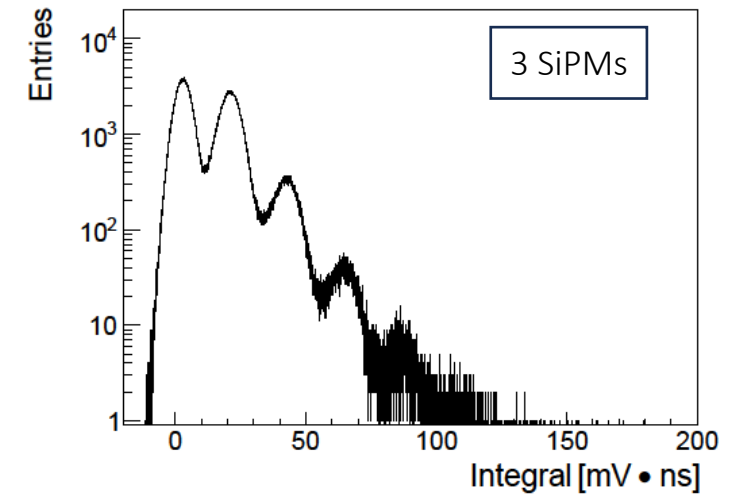
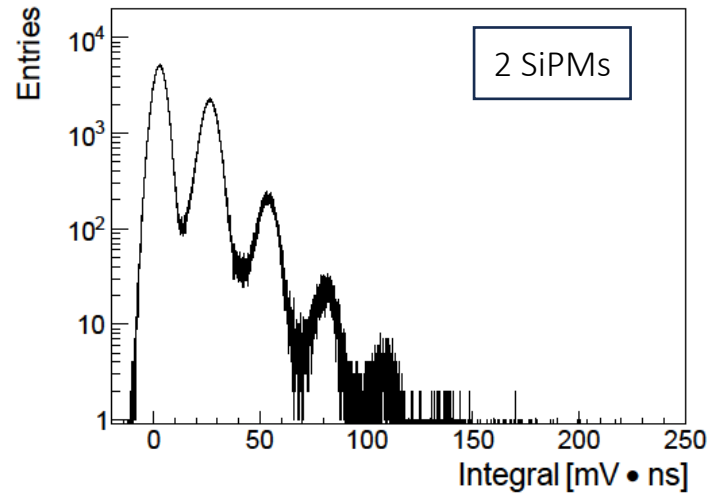
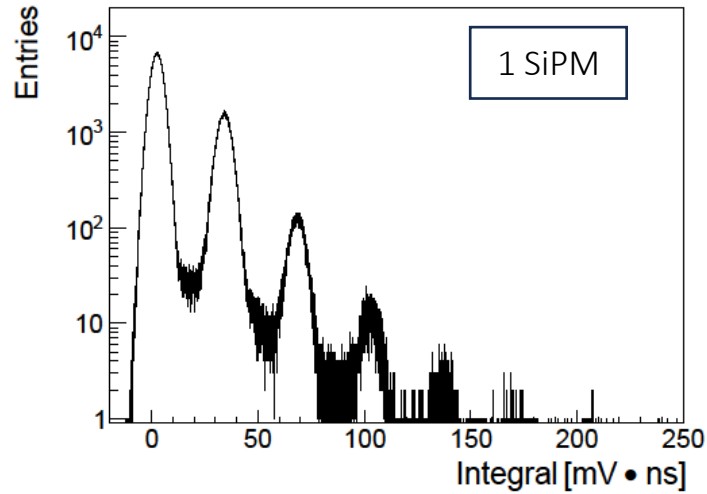

# Event characterisation

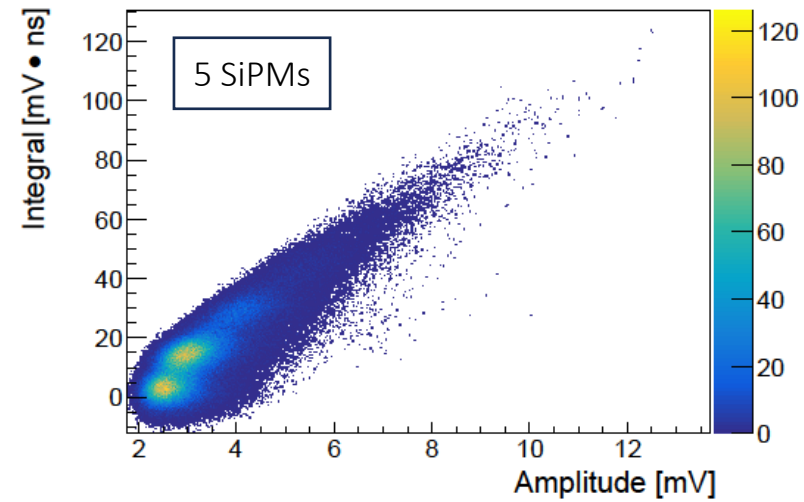
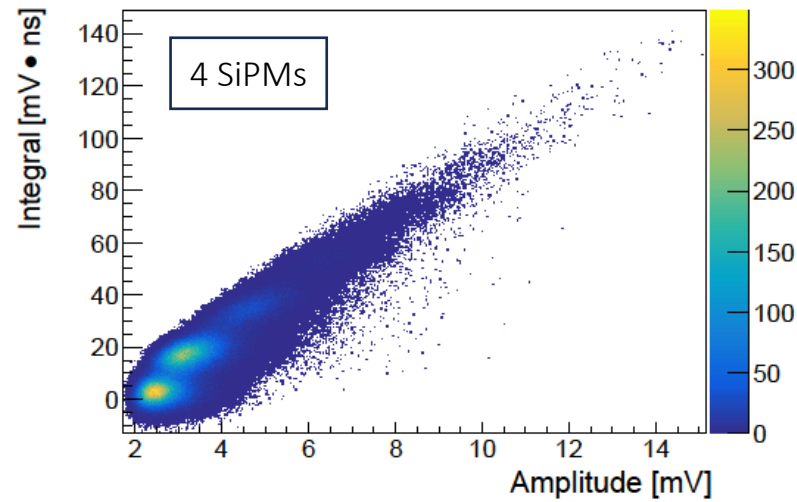
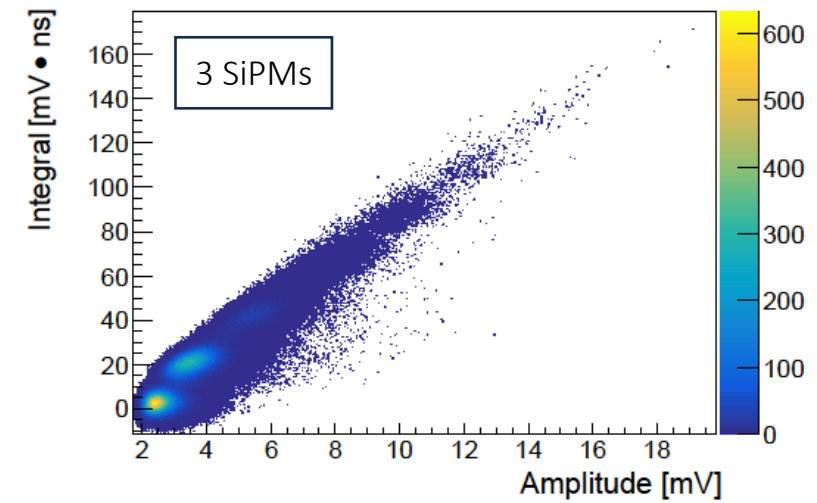
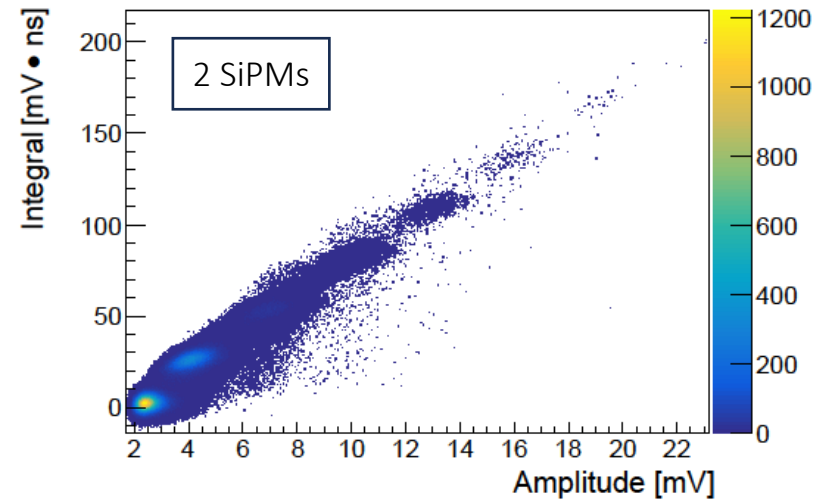
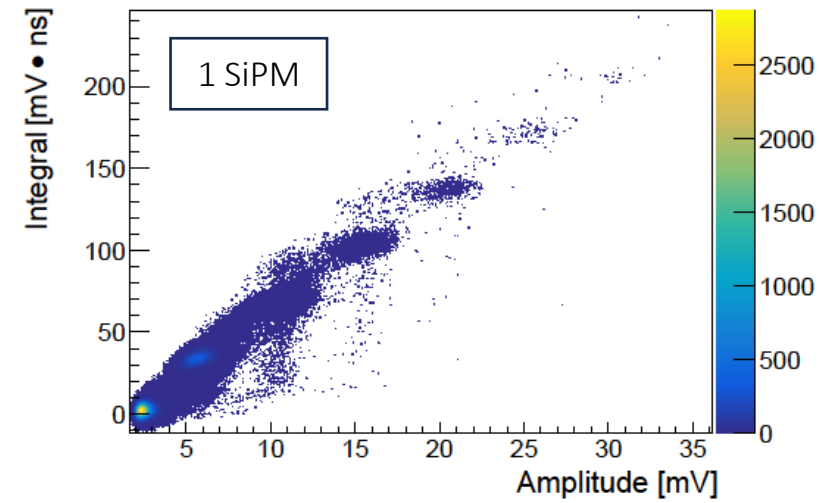

# Event characterisation

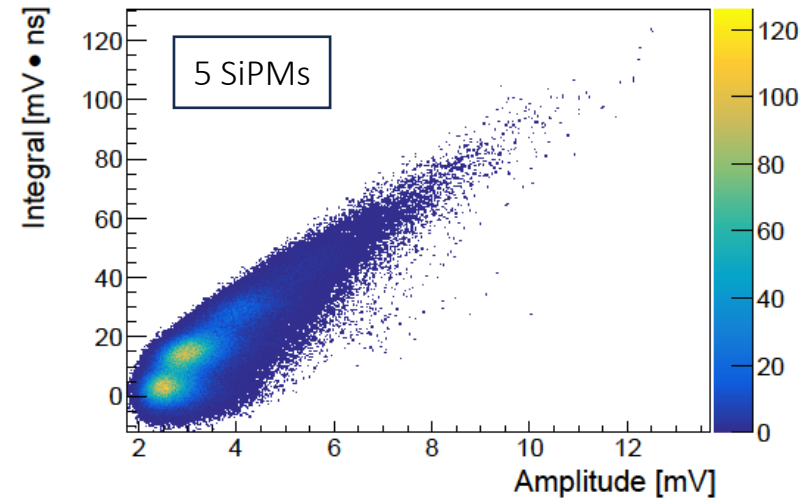
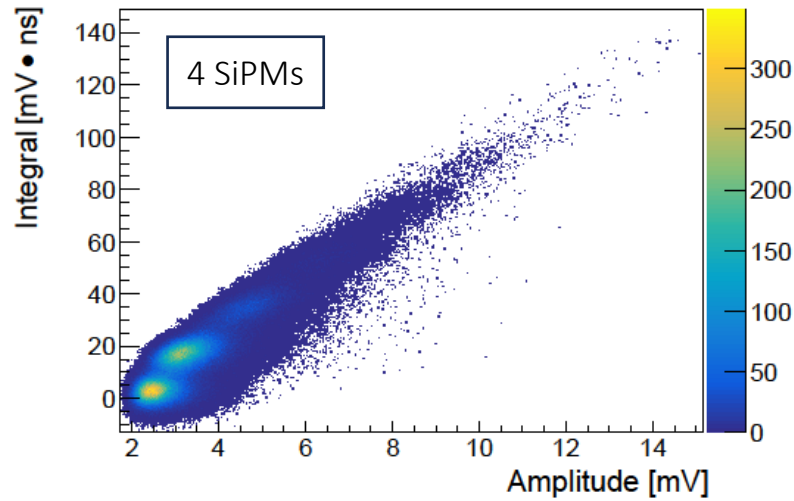
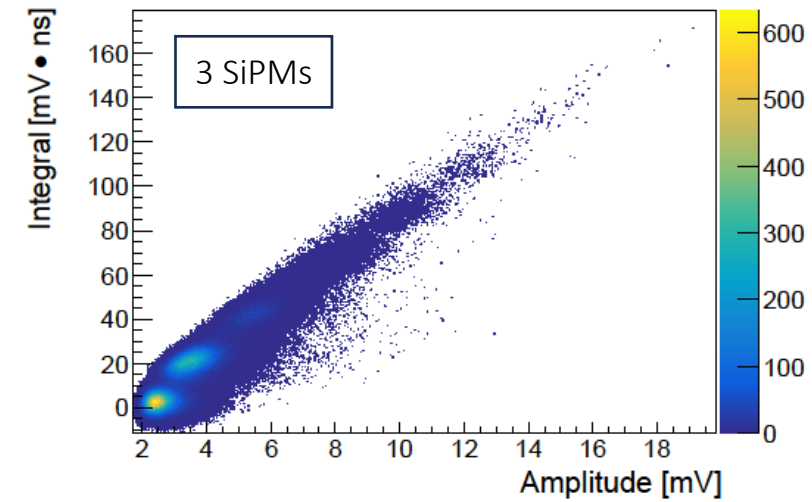
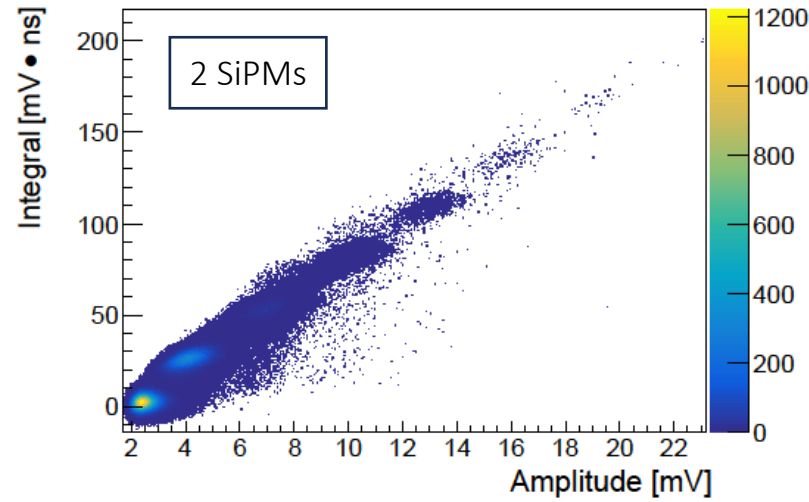
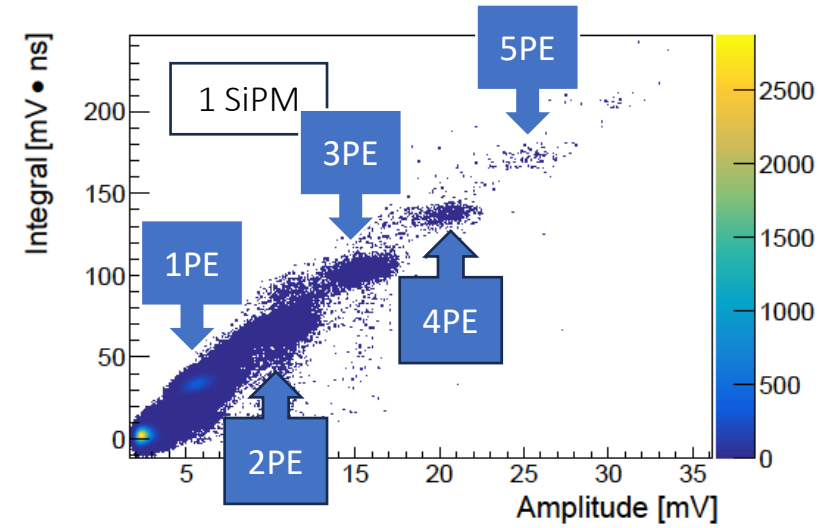

# Signal Templates

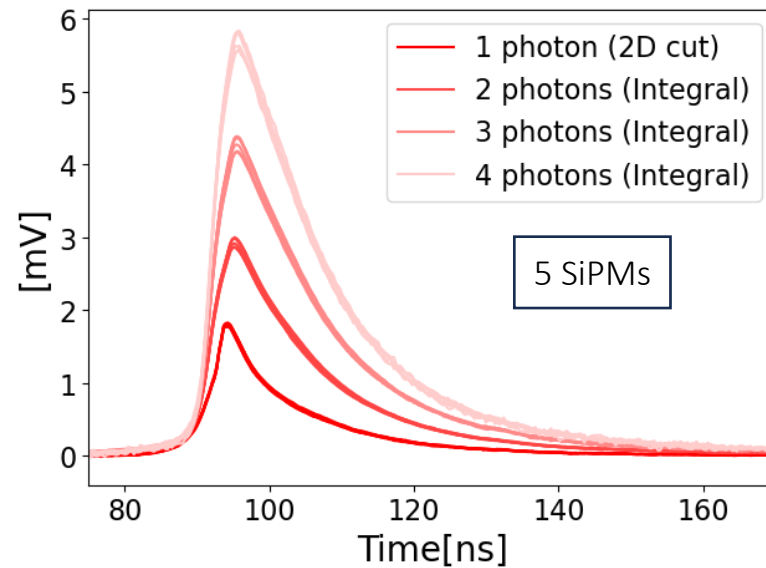
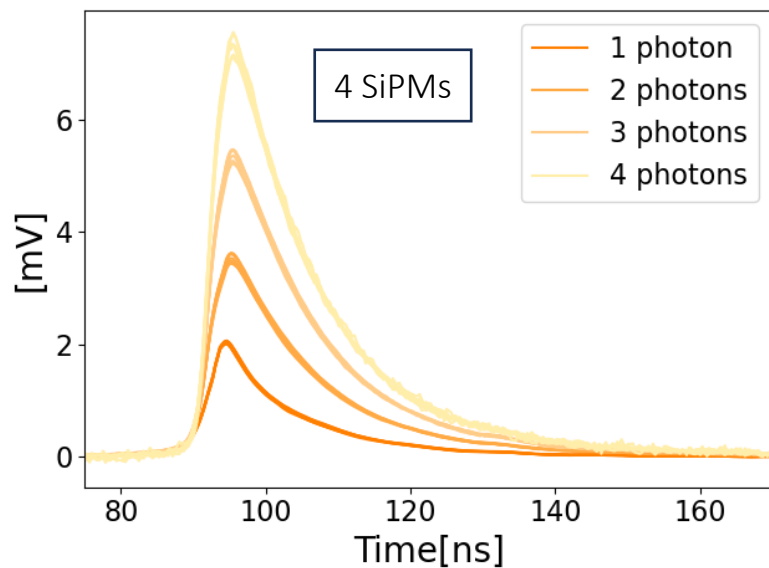
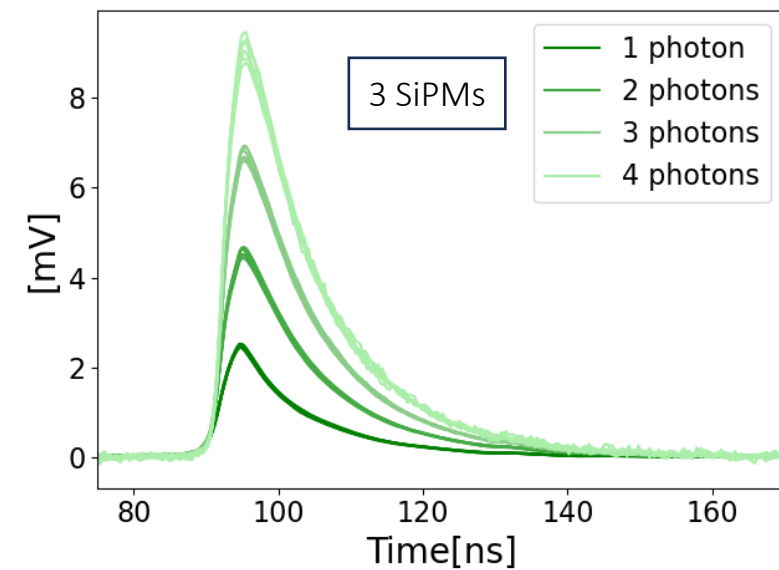
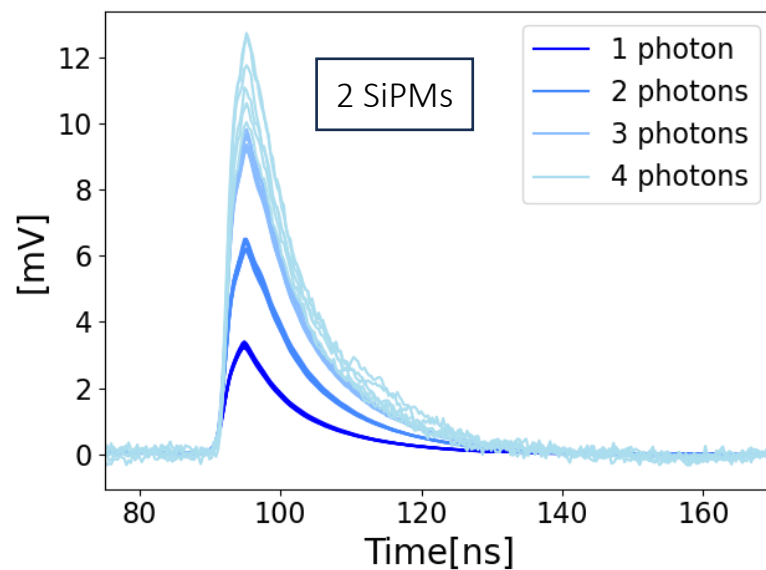
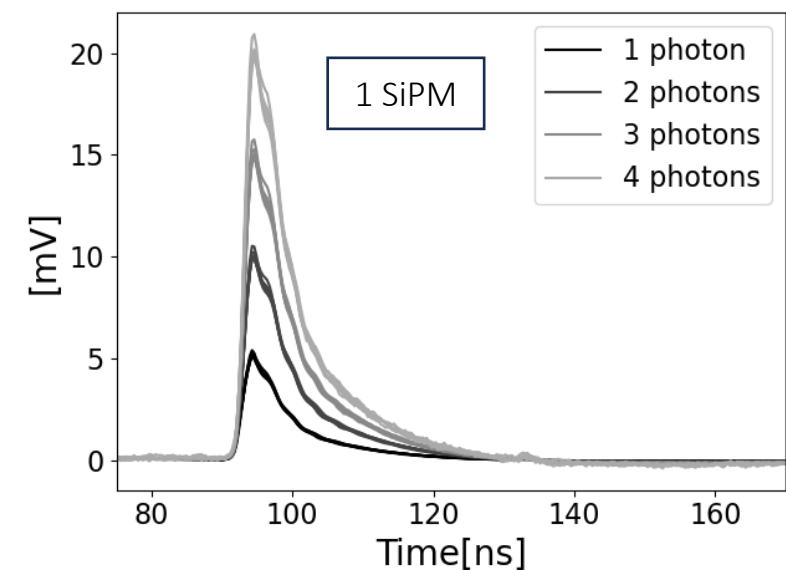

# Signal Templates

1SiPM:

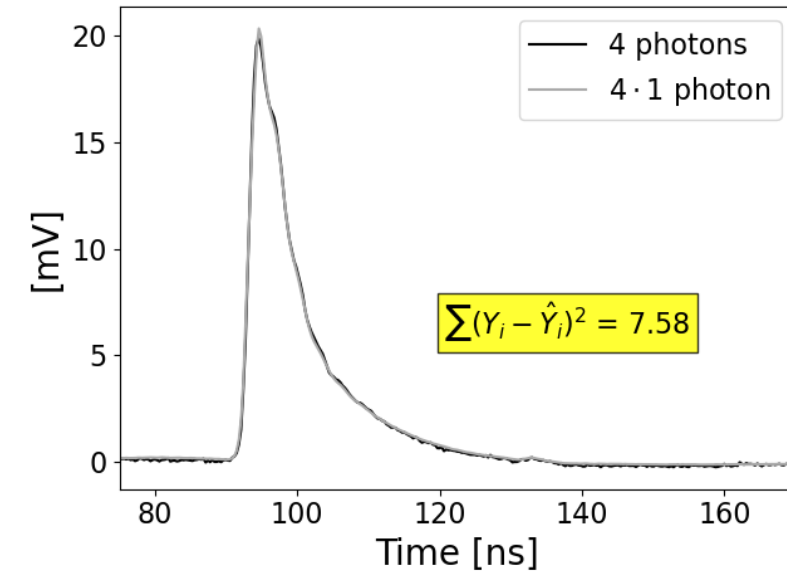
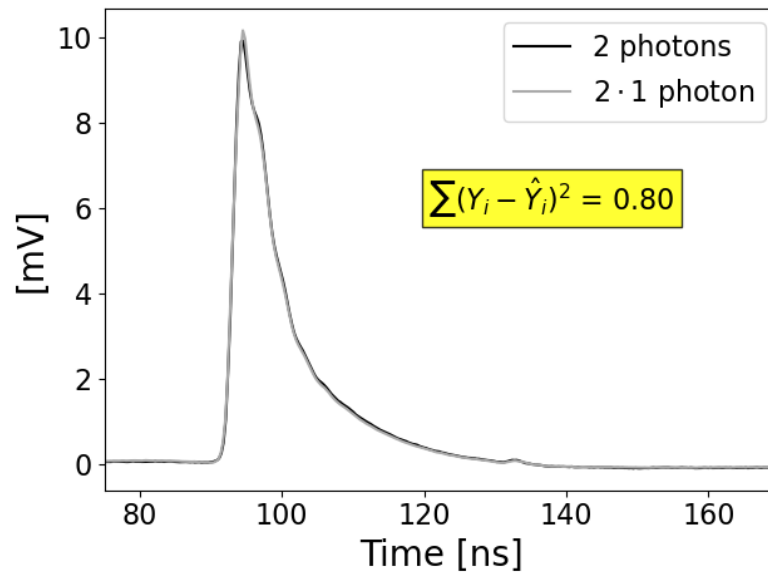
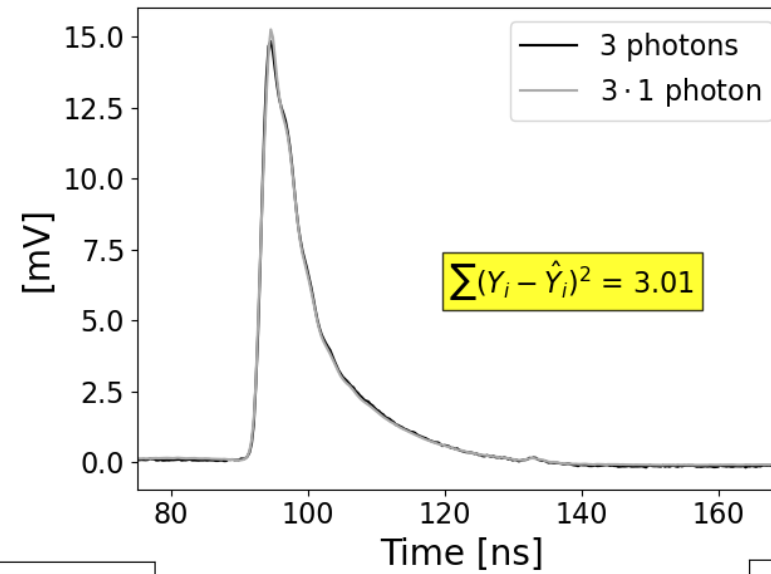

5SiPMs:

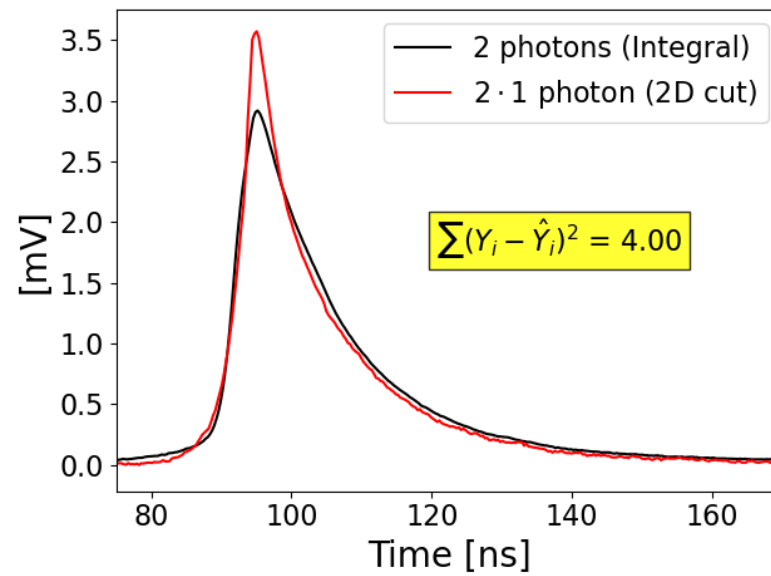

# Signal Templates

5SiPMs:

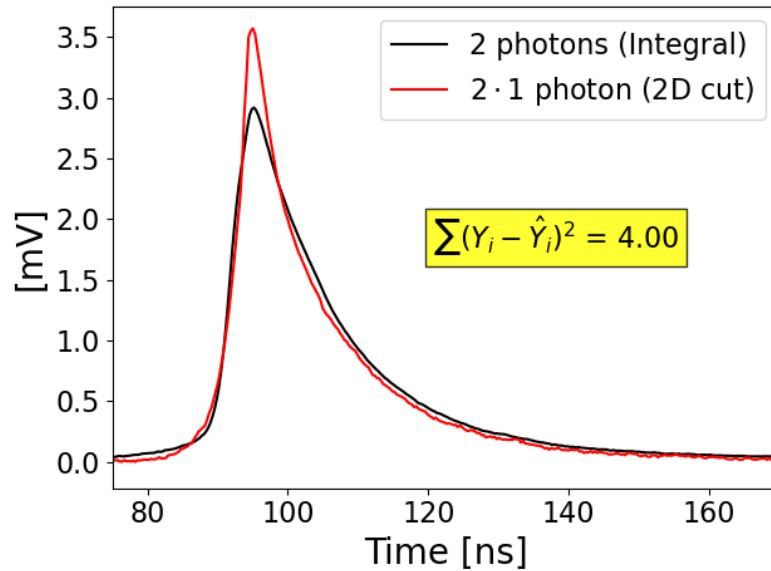

Switching from 1-photon to 2-photon template

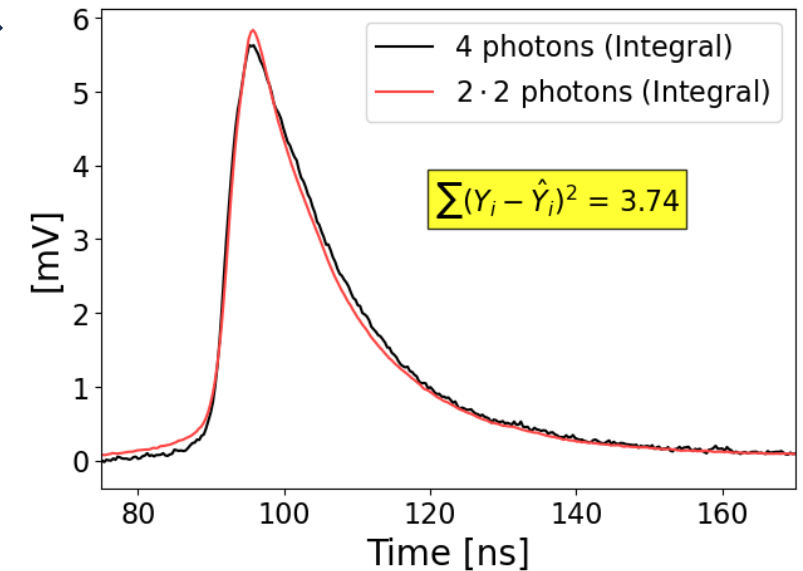
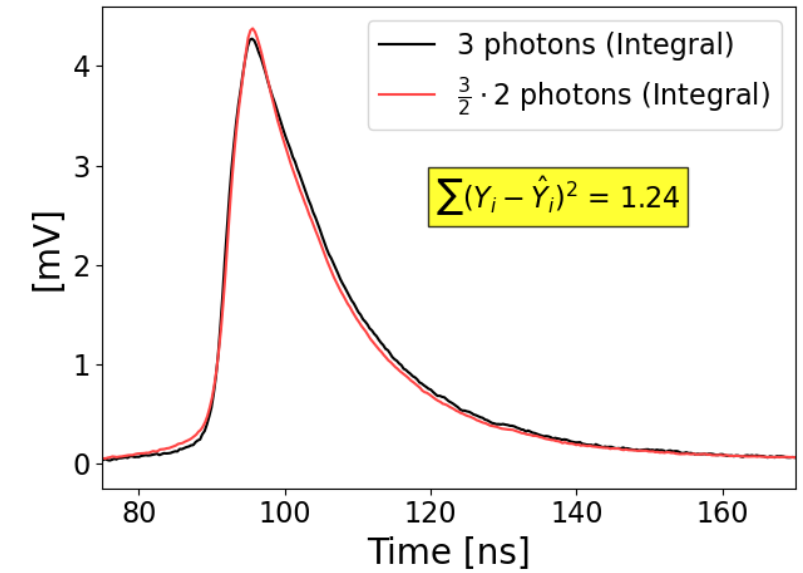

# Signal Templates

5SiPMs:

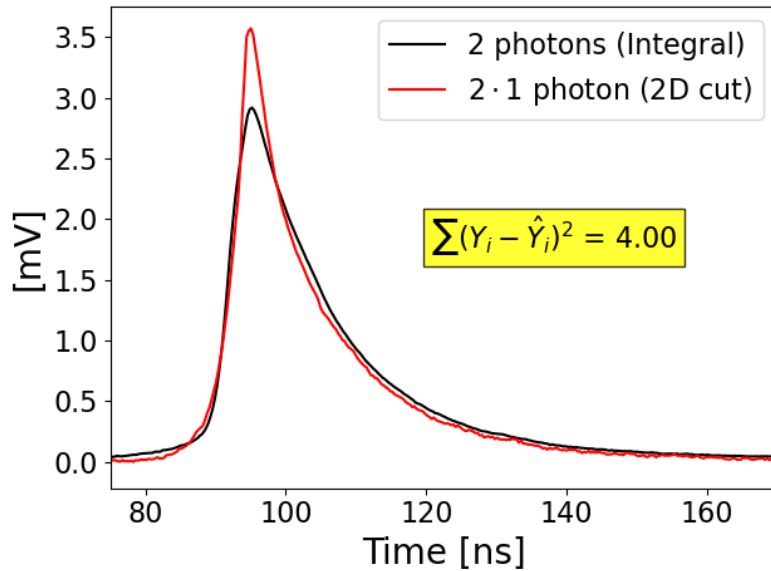

Switching from 1-photon  
to 2-photon template

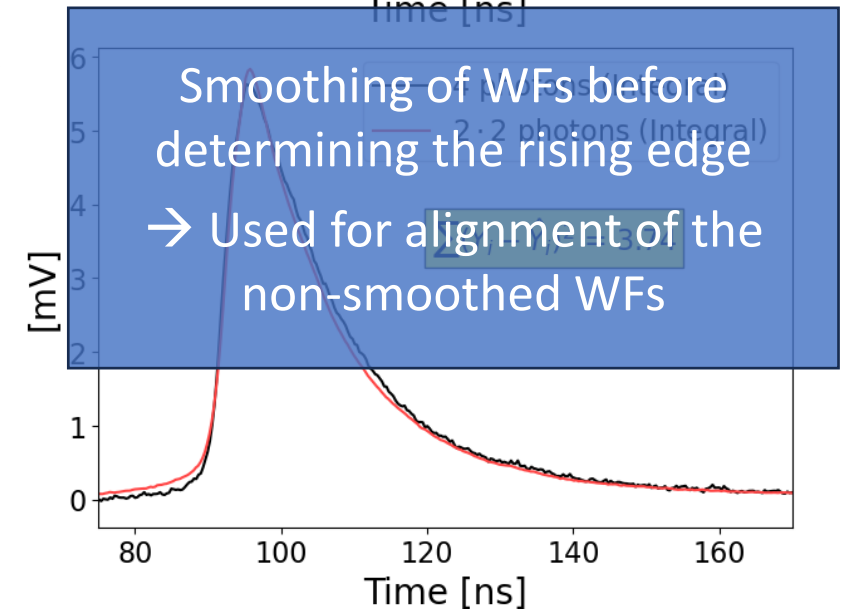
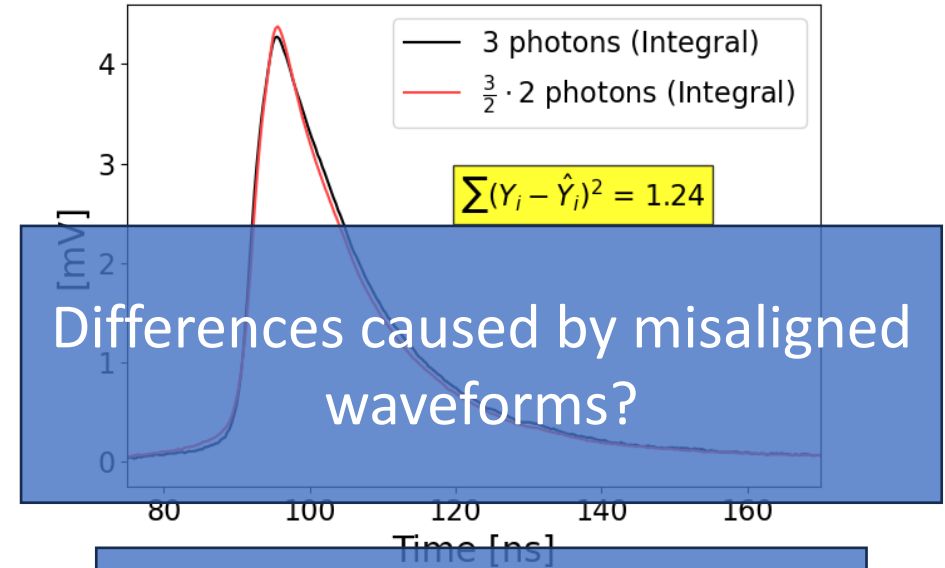

# Signal Templates

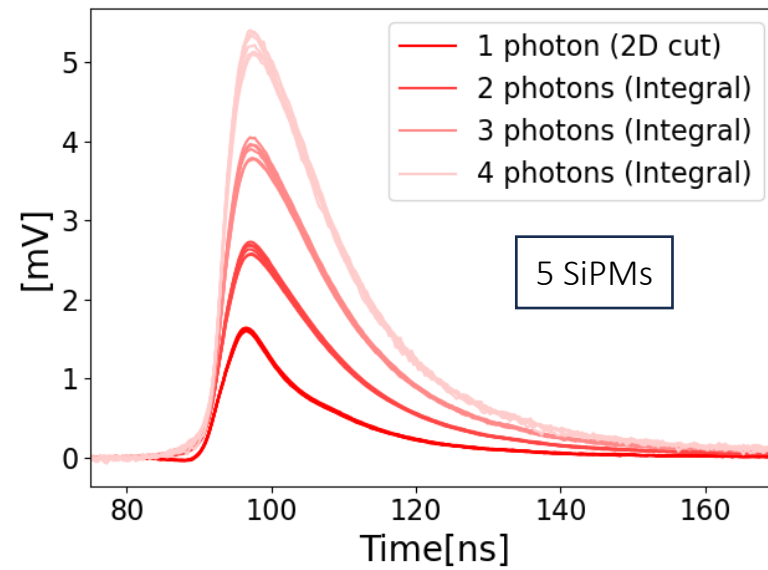
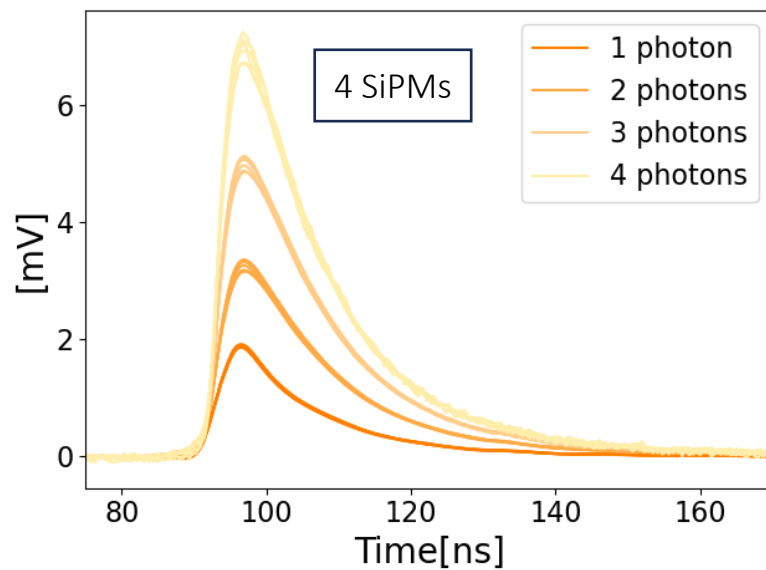
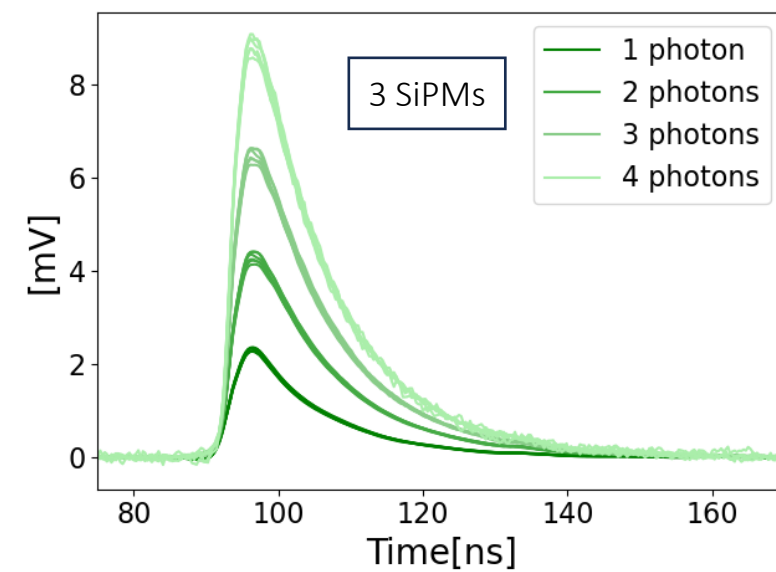
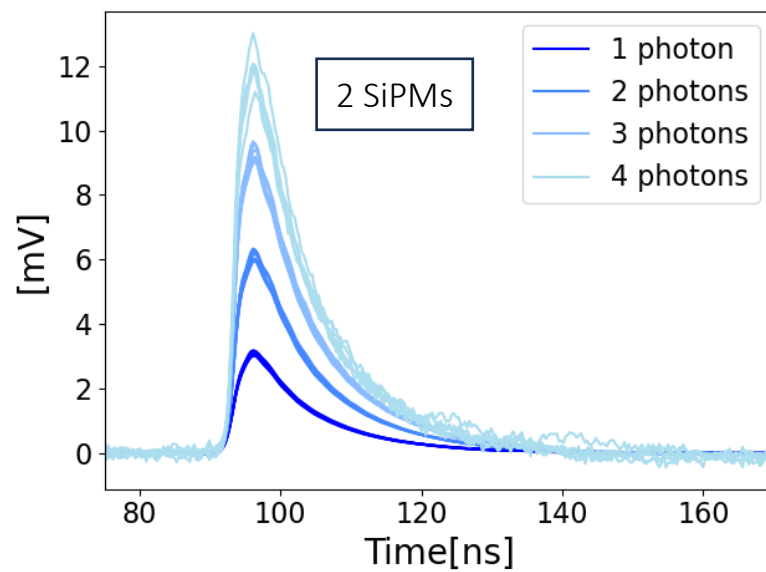
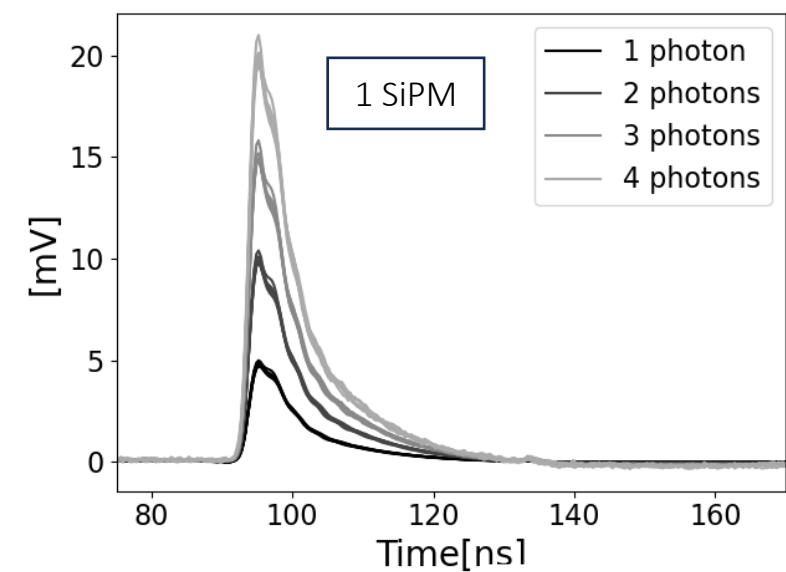

5SiPMs:

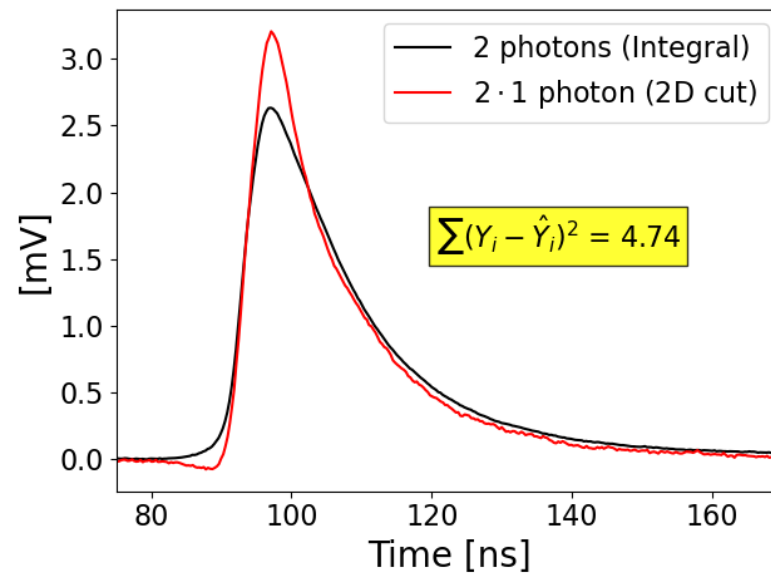

# Signal Templates

5SiPMs (using smoothed alignment):

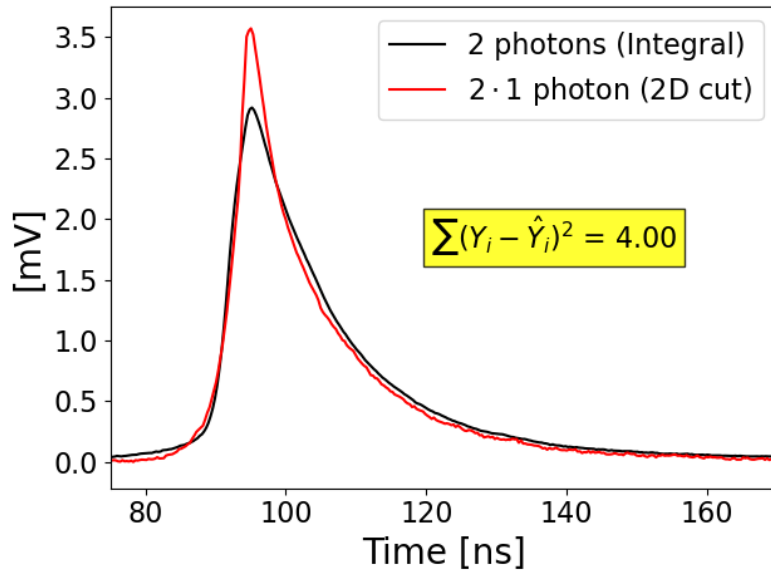

Switching from 1-photon to 2-photon template

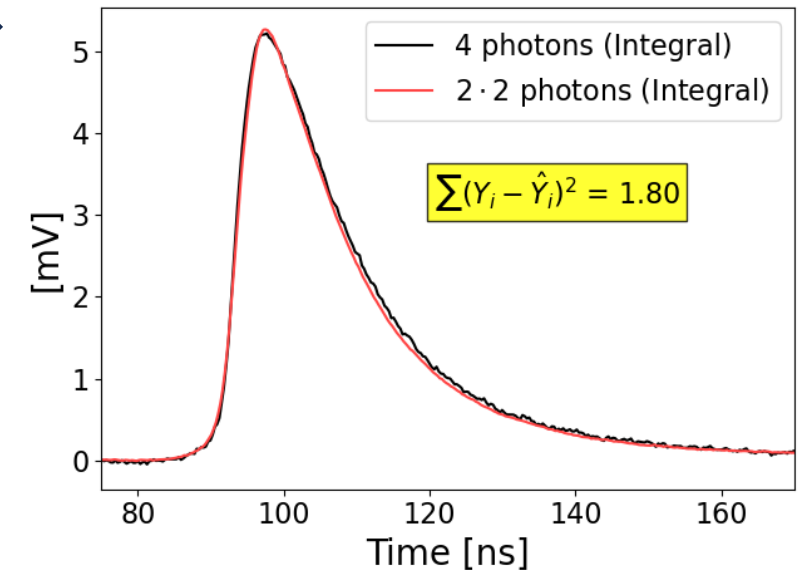
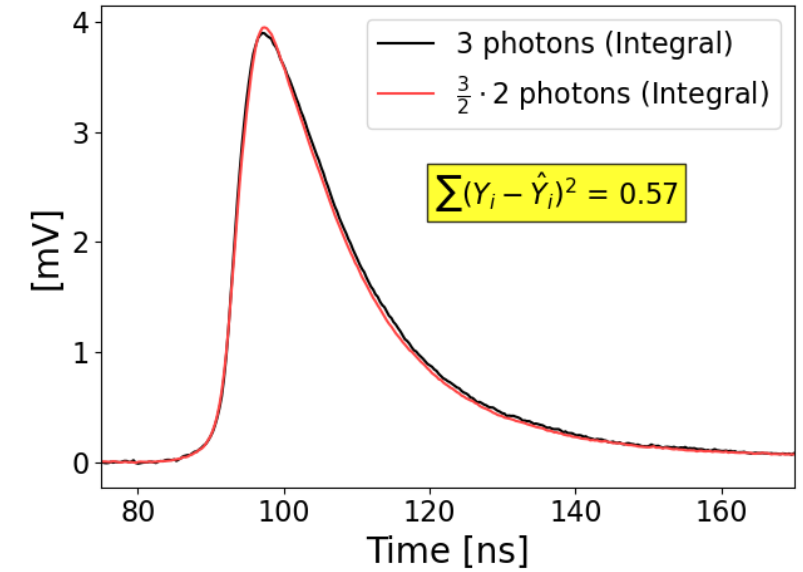

# Signal Templates

- 1 Photon
- 2 Photons halved
- 1 Photon (smoothed alignment)
- 2 Photons halved (smoothed alignment)

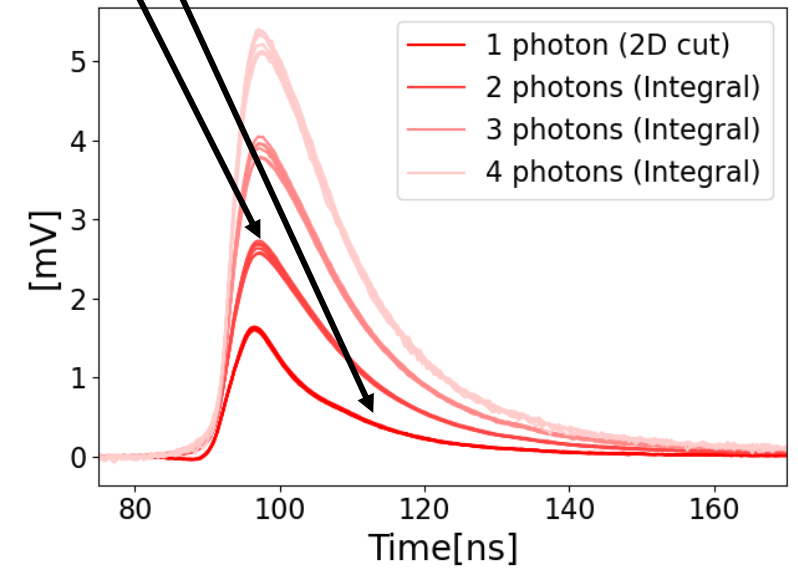
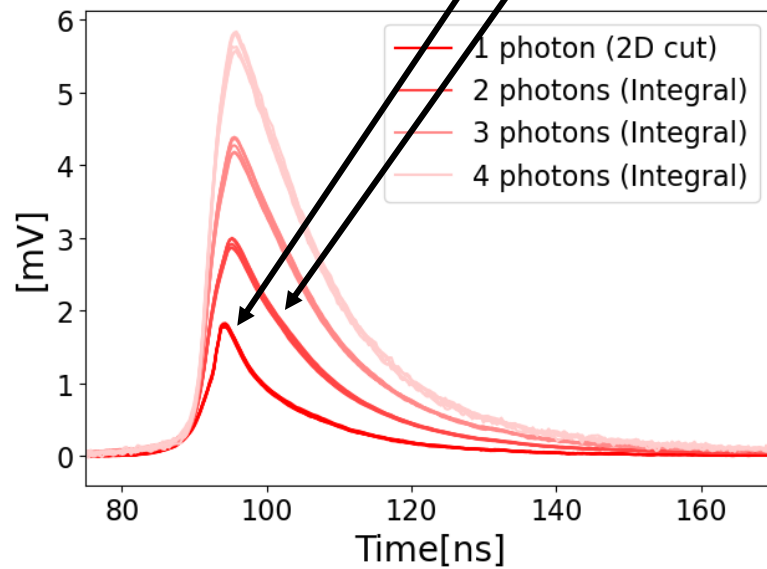

# Signal Templates

- 1 Photon

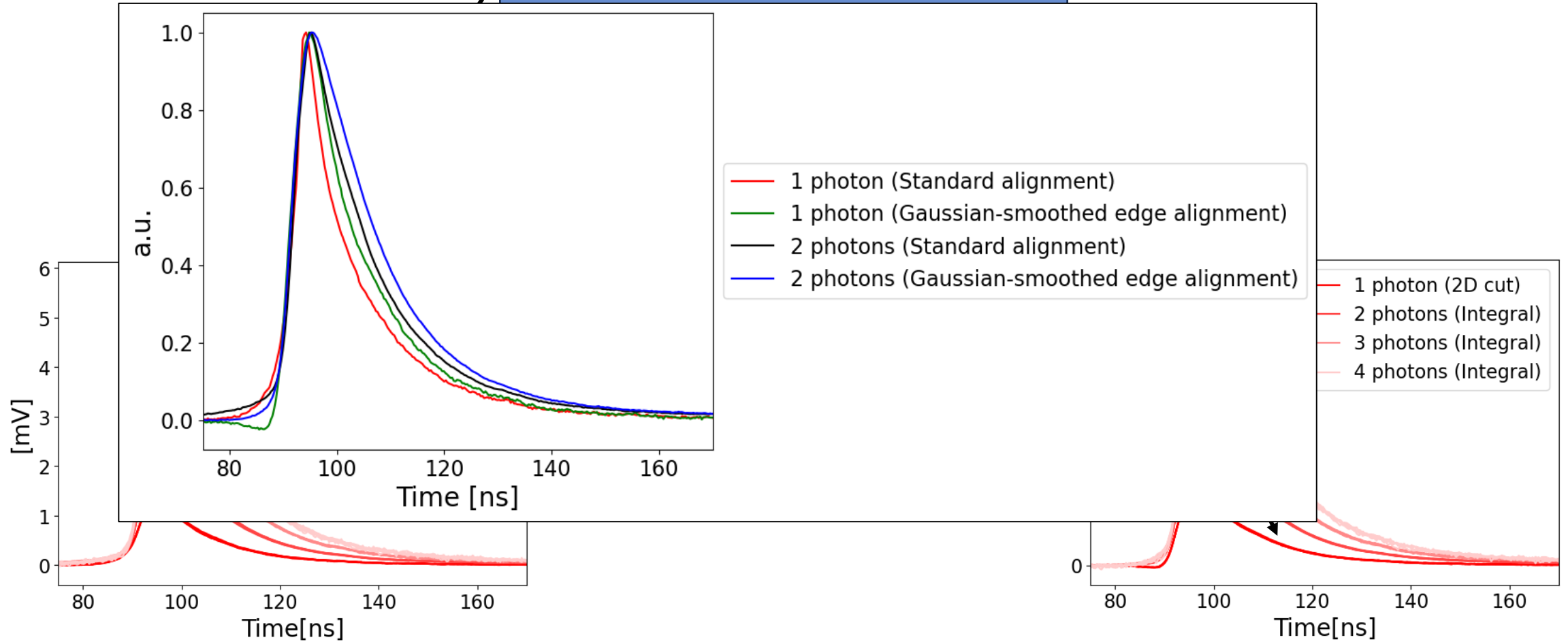

## Up till now:

- Obtained representative templates for detector response to single photons and 2-4 photons
  - But: Unsure of “true” shape for 5 SiPM setup
- Confirmed that the addition of templates to form a larger waveform works for low number of photons

## Up till now:

- Obtained representative templates for detector response to single photons and 2-4 photons
  - But: Unsure of “true” shape for 5 SiPM setup
- Confirmed that the addition of templates to form a larger waveform works for low number of photons

## Next:

- Automated template-based reconstruction method for larger waveforms
- Testing method with waveforms recorded during the test beam in May at CERN
- Looking into correlations between number of photons in a signal and waveform characteristics

# Reconstruction Method

- Apply threshold to WF:  
→ 90% of the height of the template
- These are the only positions where photons can be placed

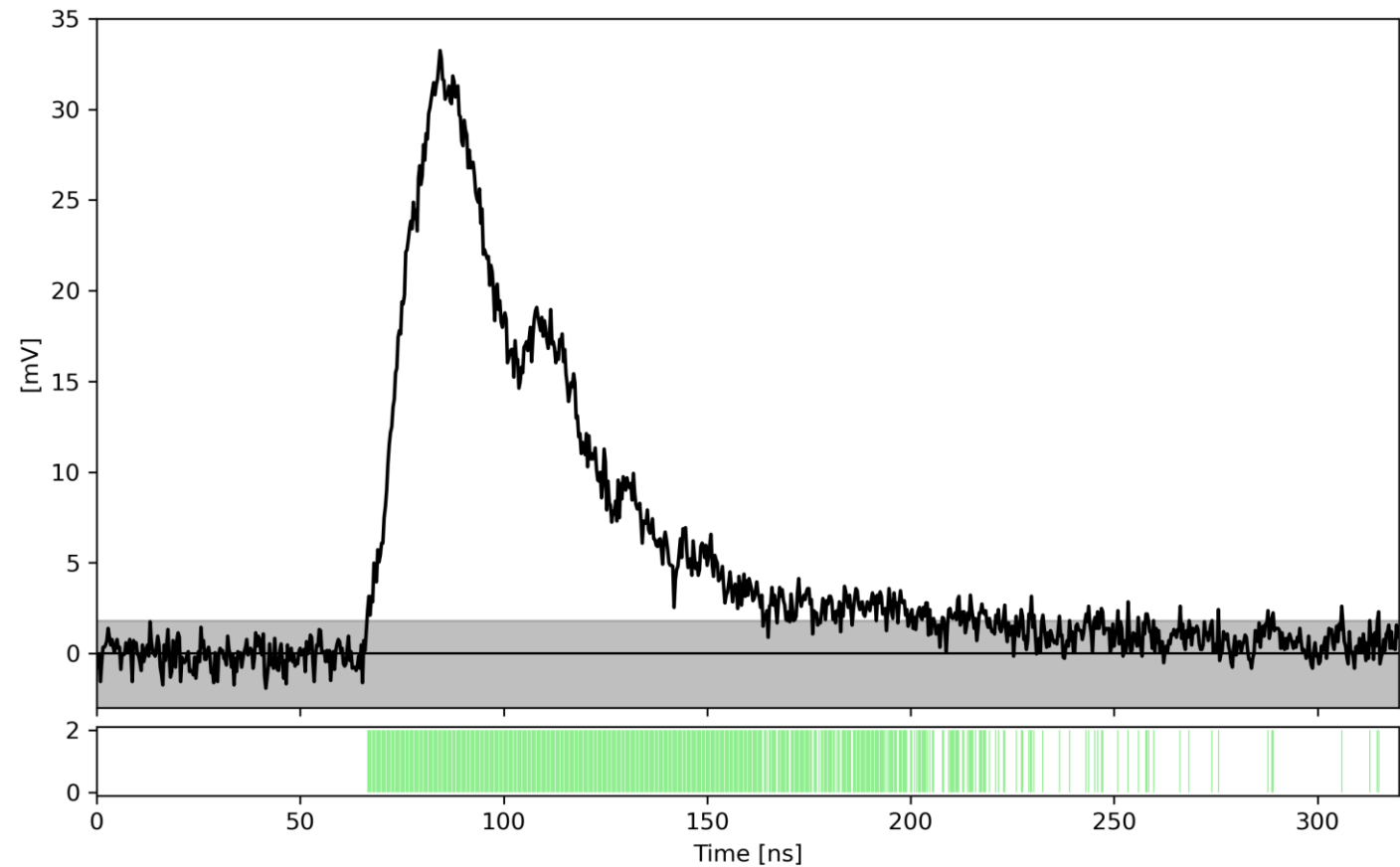

# Reconstruction Method

- The „basearray“ is the fitted curve:  
→ Initially a line at zero

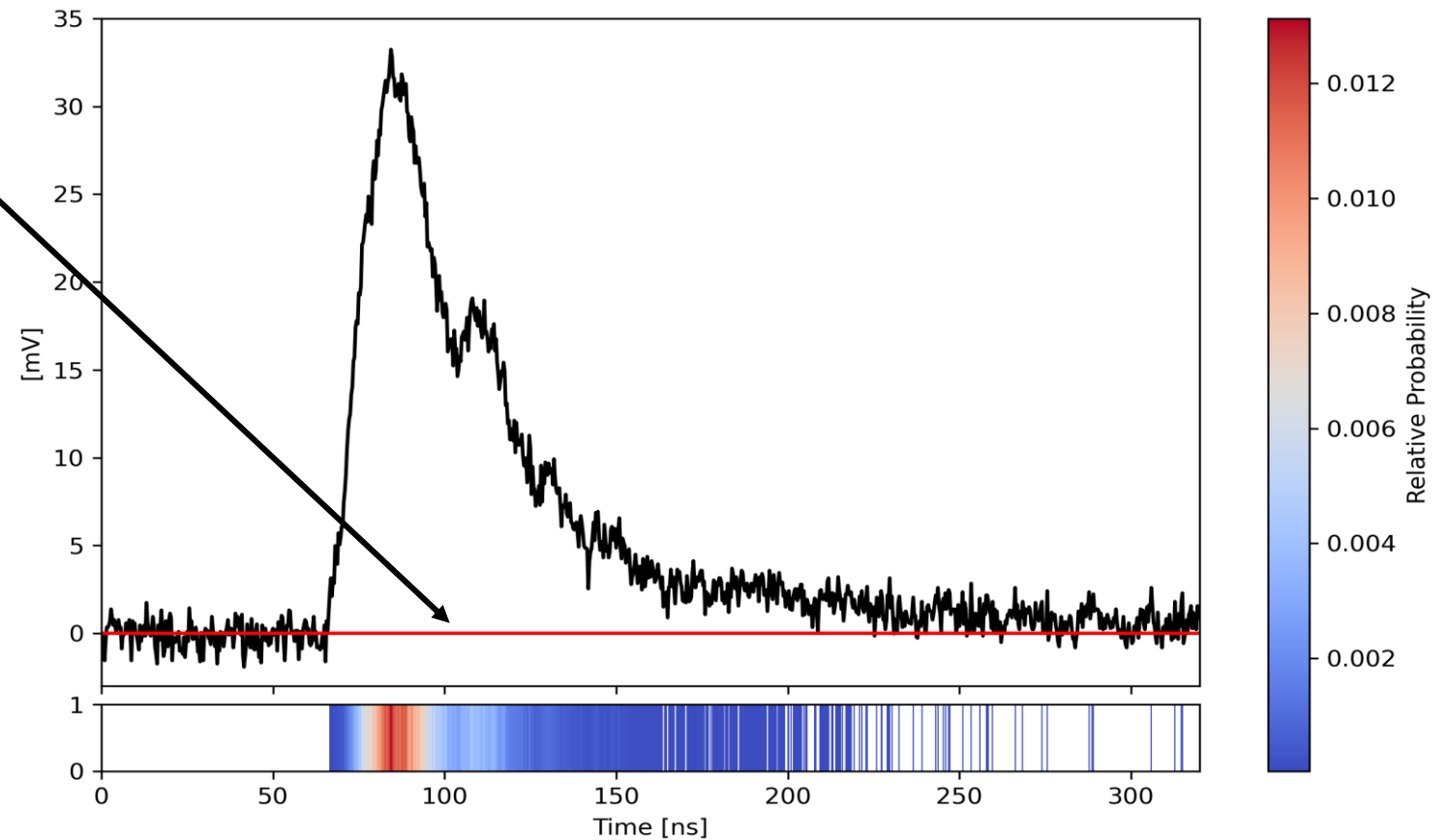

# Reconstruction Method

- The „basearray“ is the fitted curve:  
→ Initially a line at zero

- Calculate difference between fitted curve and waveform data for the approved bins  
→ Use its squares as weights

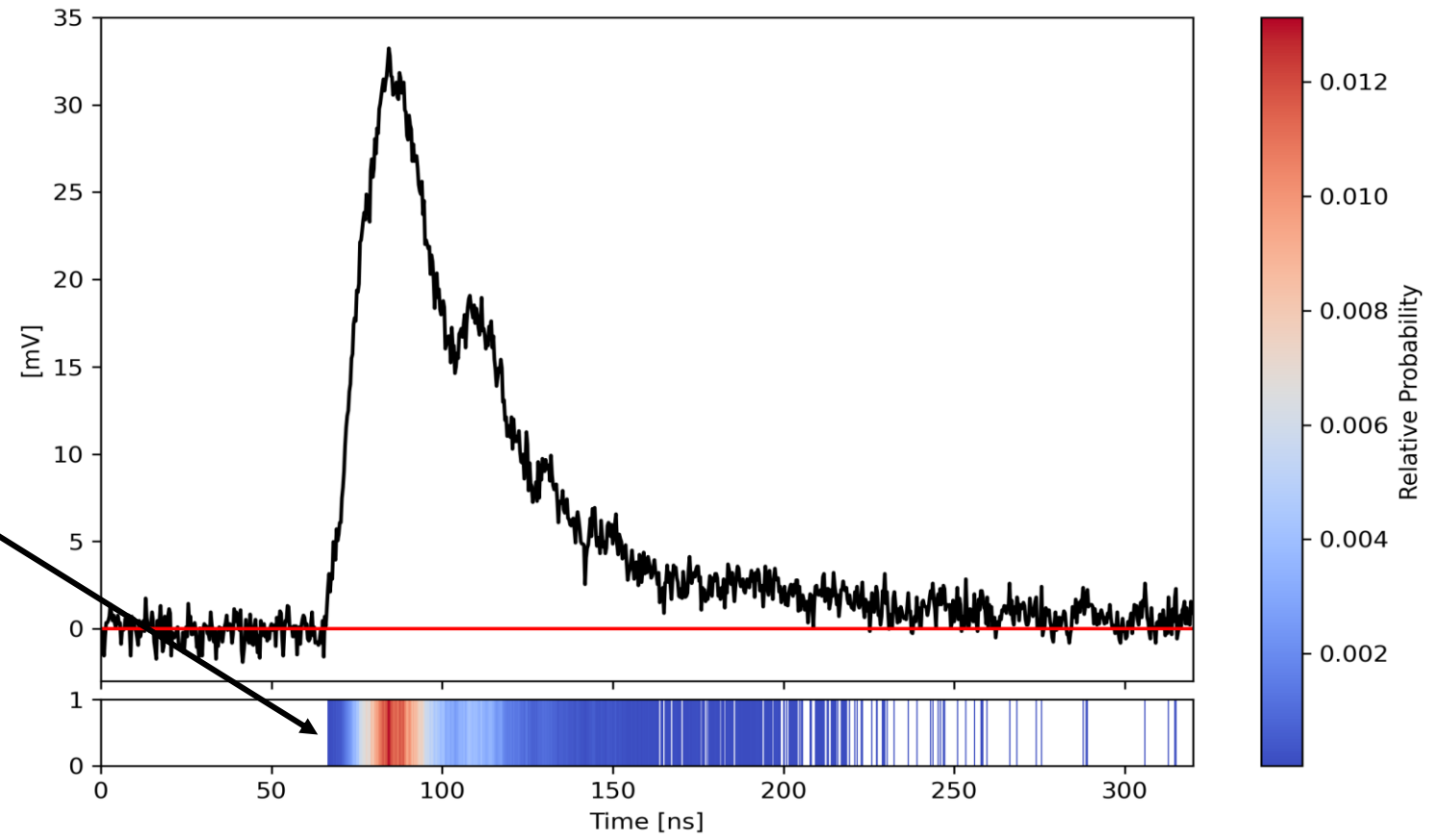

# Reconstruction Method

- Place a photon at position chosen by weighted random generator

- Calculate residual sum of squares to determine goodness of fit

Fit does not improve

Fit improves

Save position in new basearray

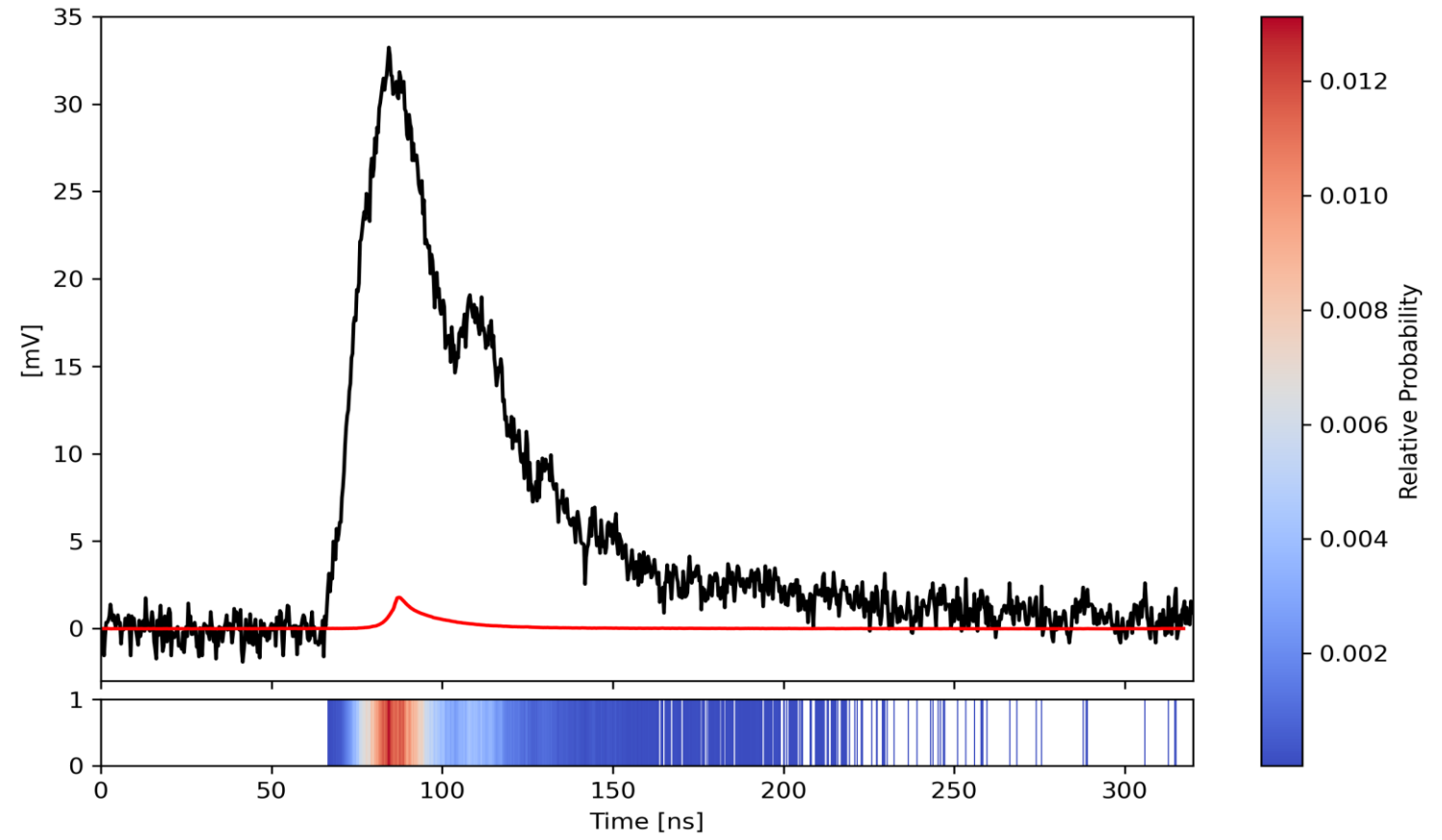

# Reconstruction Method

- Place a photon at position chosen by weighted random generator

- Calculate residual sum of squares to determine goodness of fit

Fit does not improve

Reject Position

Choose new Position

Fit improves

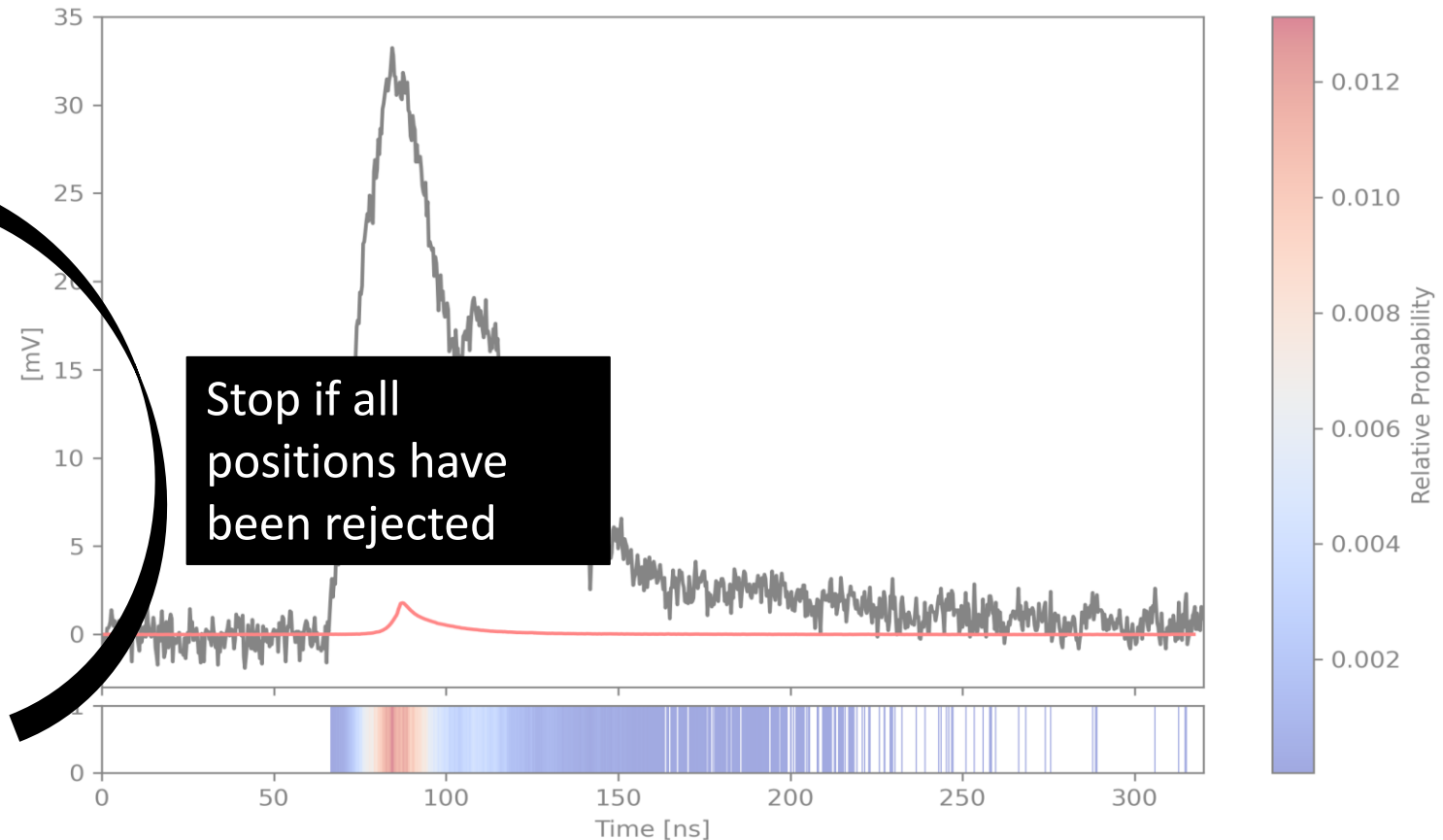

# Reconstruction Method

- Repeat entire process 1000 times and use best result

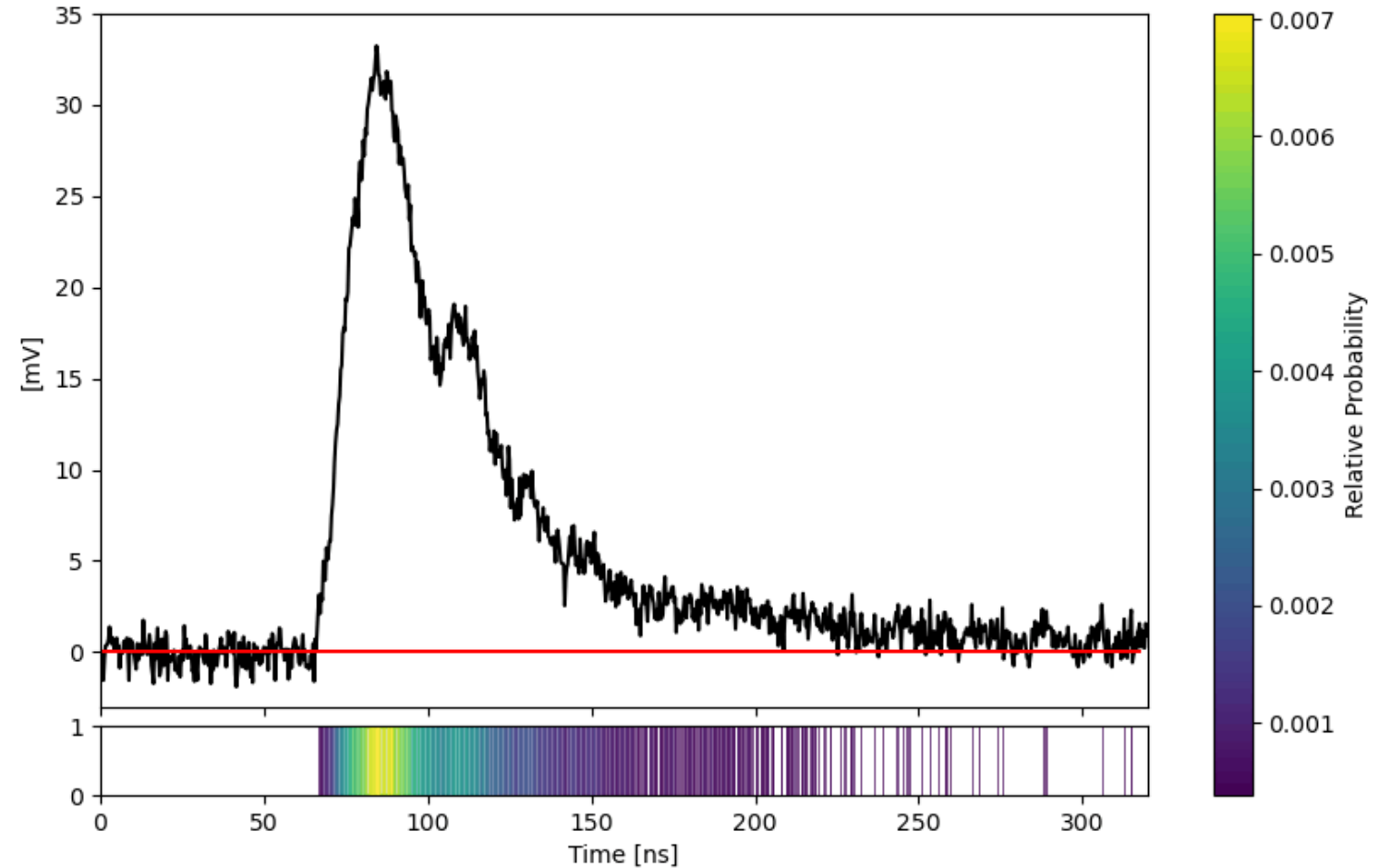

# Reconstruction Method

Some results for WFs from Testbeam in May 2025:

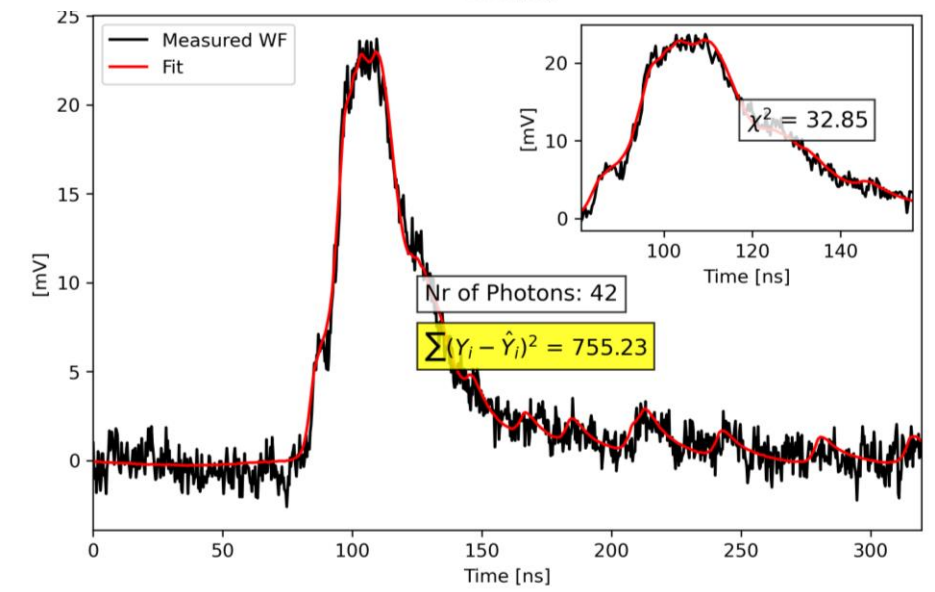
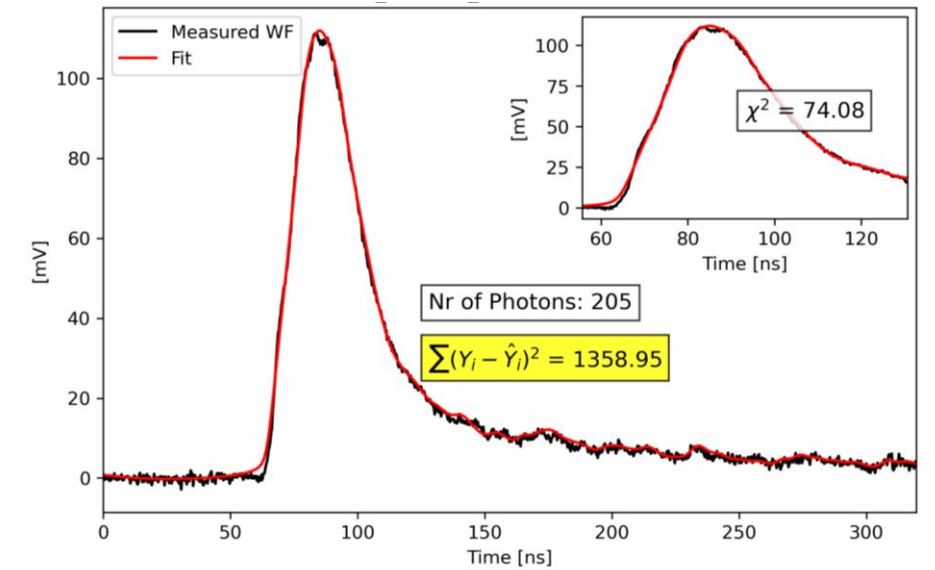
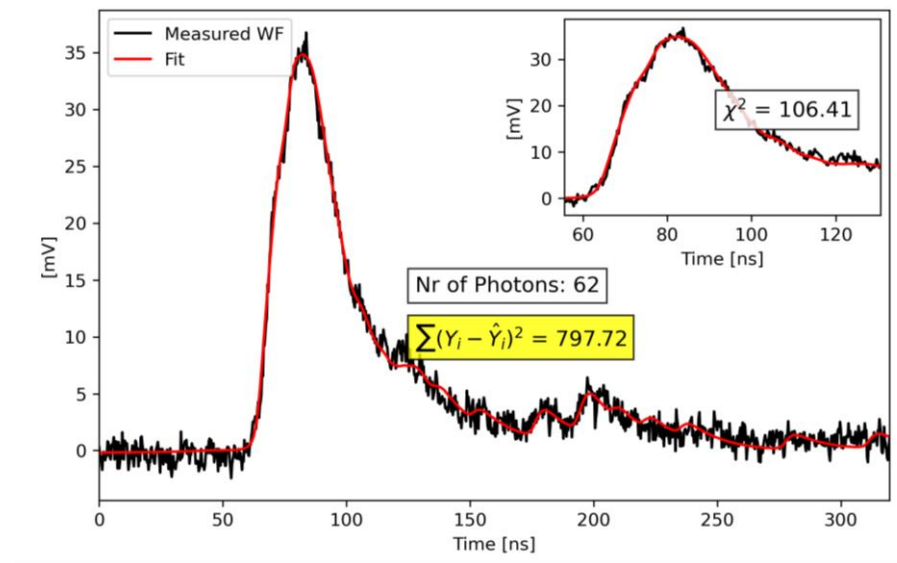

# Results

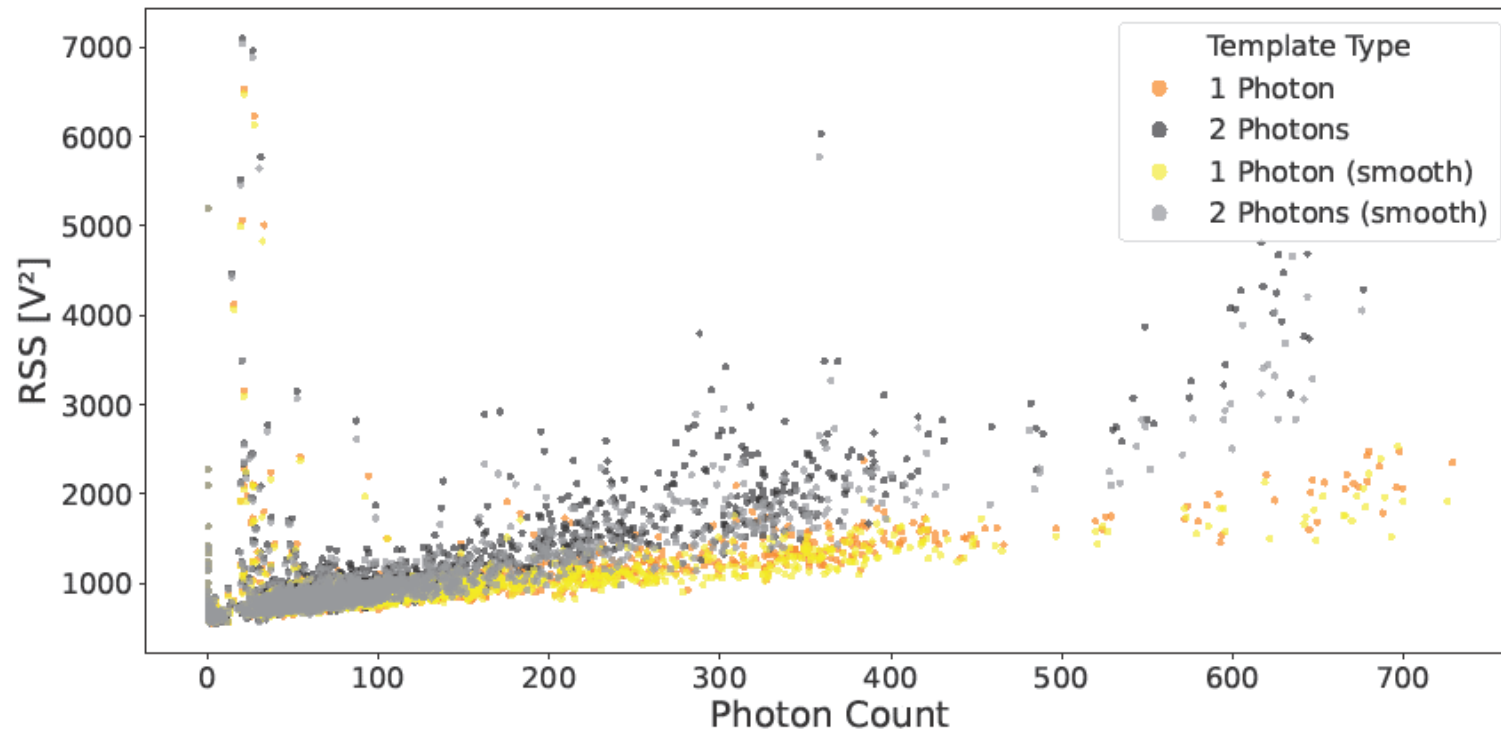

- Goodness of fit decreases for larger signals
- Noise cannot be modelled

# Results

- Running the method for the same WFs 10 times
- Look into Mean and Stdev of the results

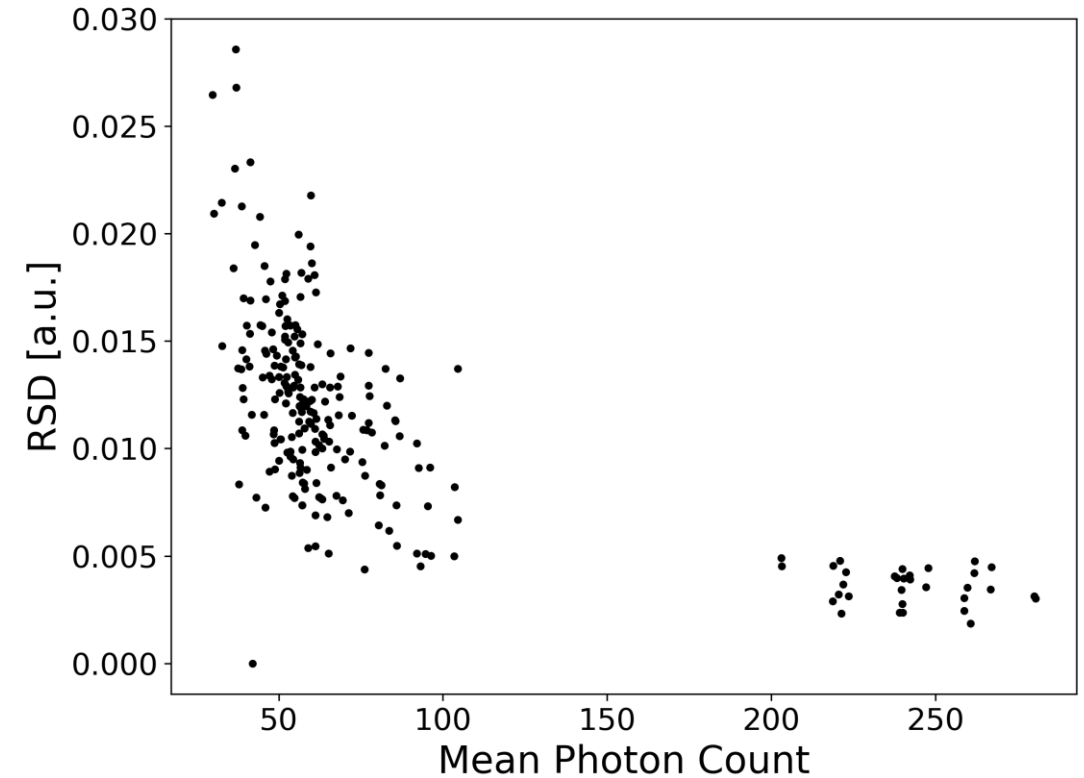
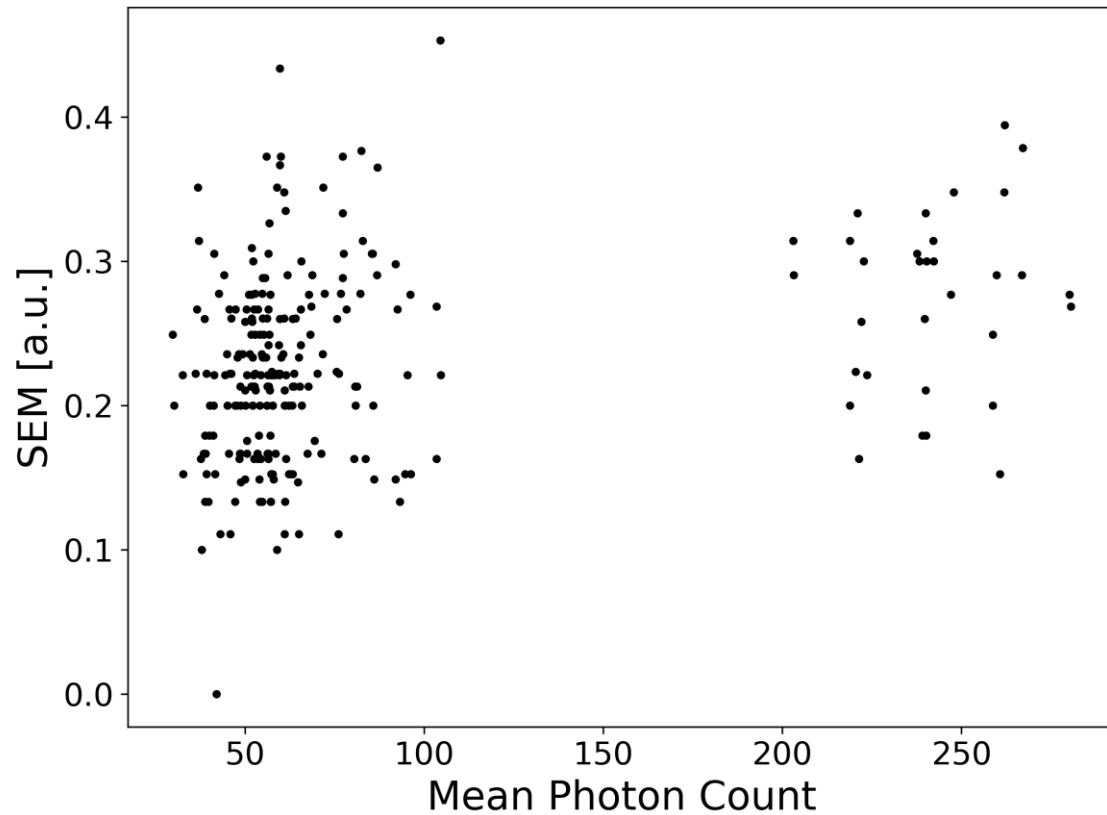

- Relative uncertainty decreases with the signal size

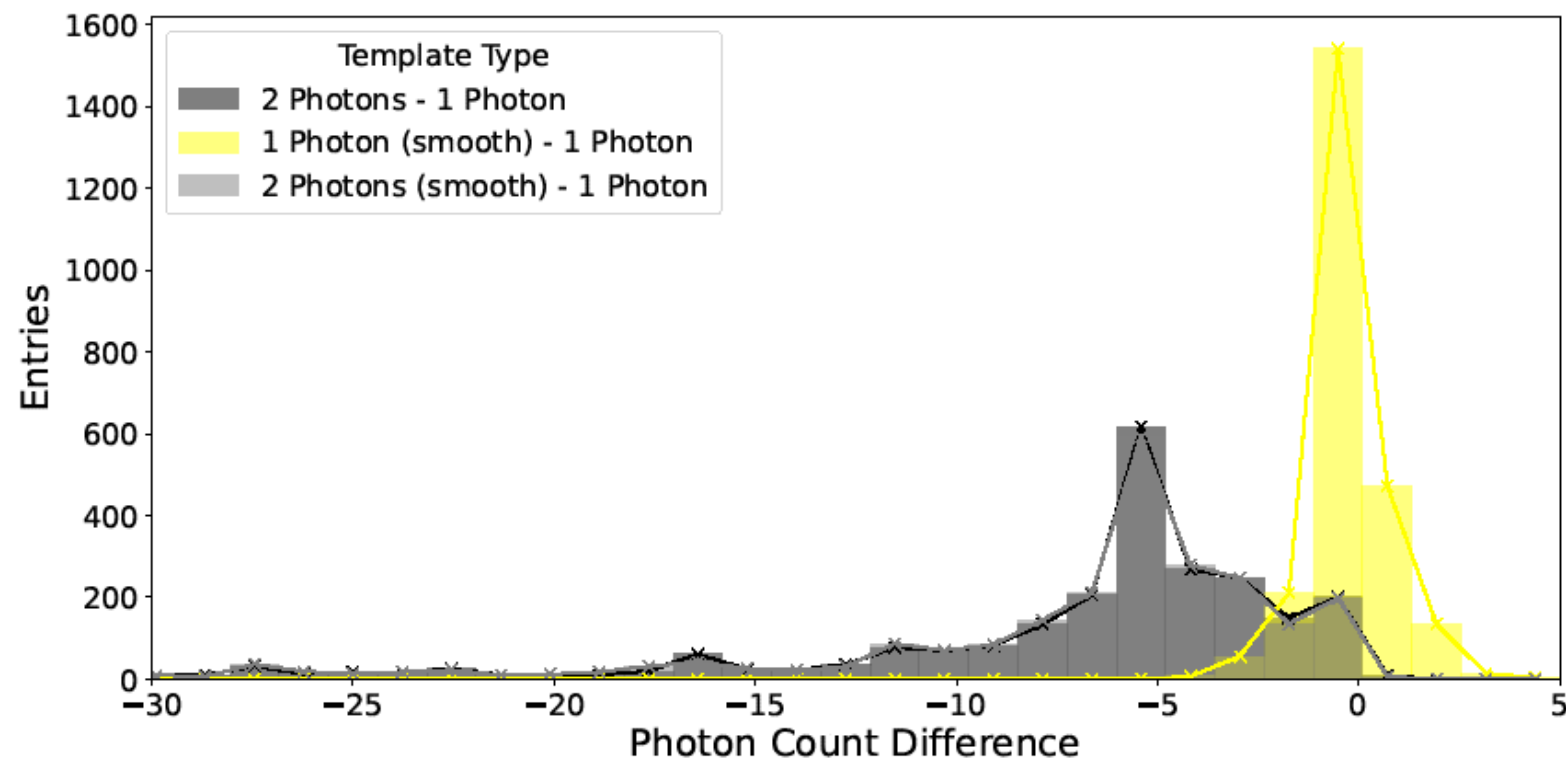

- Choice of template can affect results significantly

- Look into the residual sum of squares for the four templates

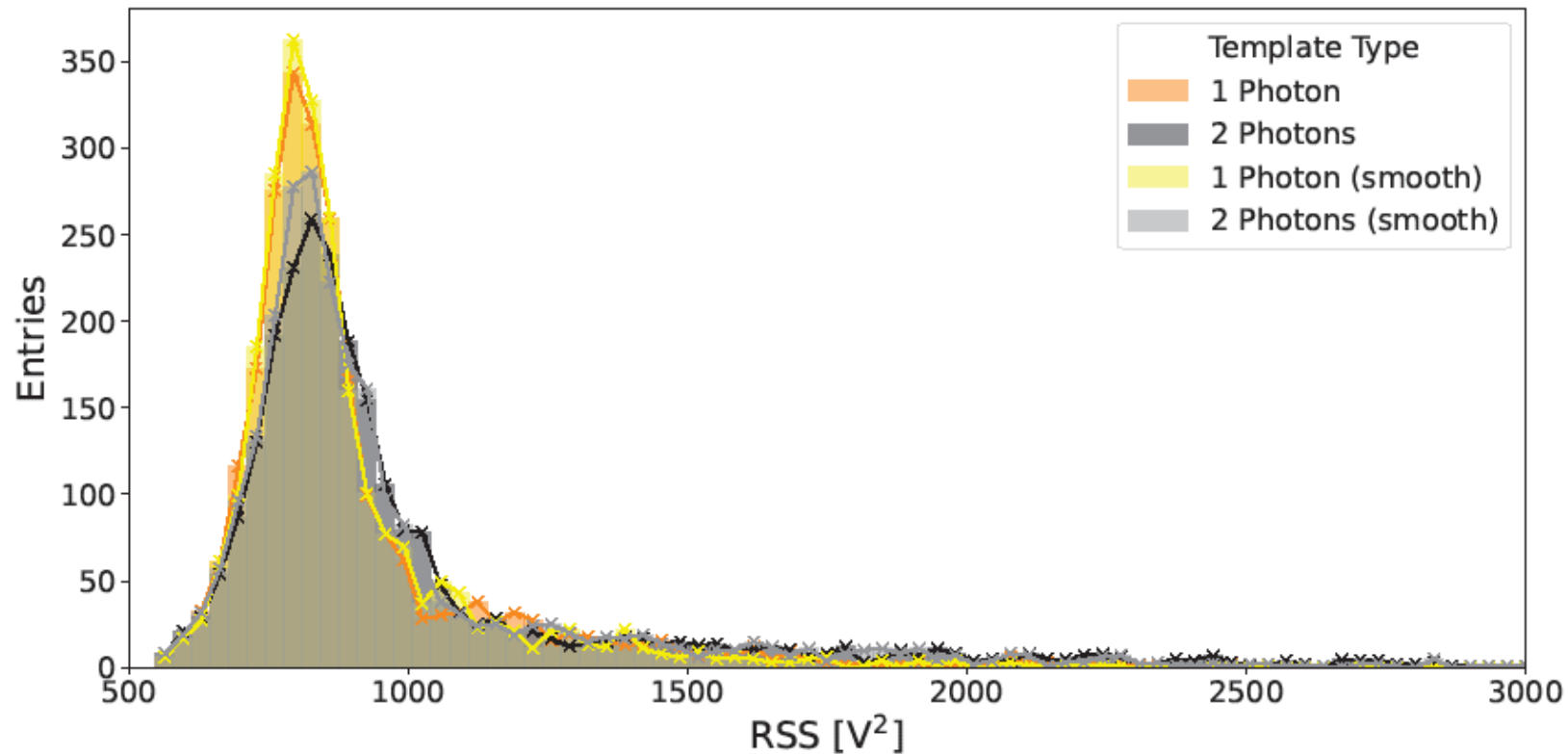

- Templates of equal photon-multiplicities perform similarly
- 1-Photon templates perform slightly better

- Reconstruction method is computationally expensive
  - Not feasible to store entire waveforms in the final SBT
- Find parameter to accurately translate photon number

Amplitude of WF:

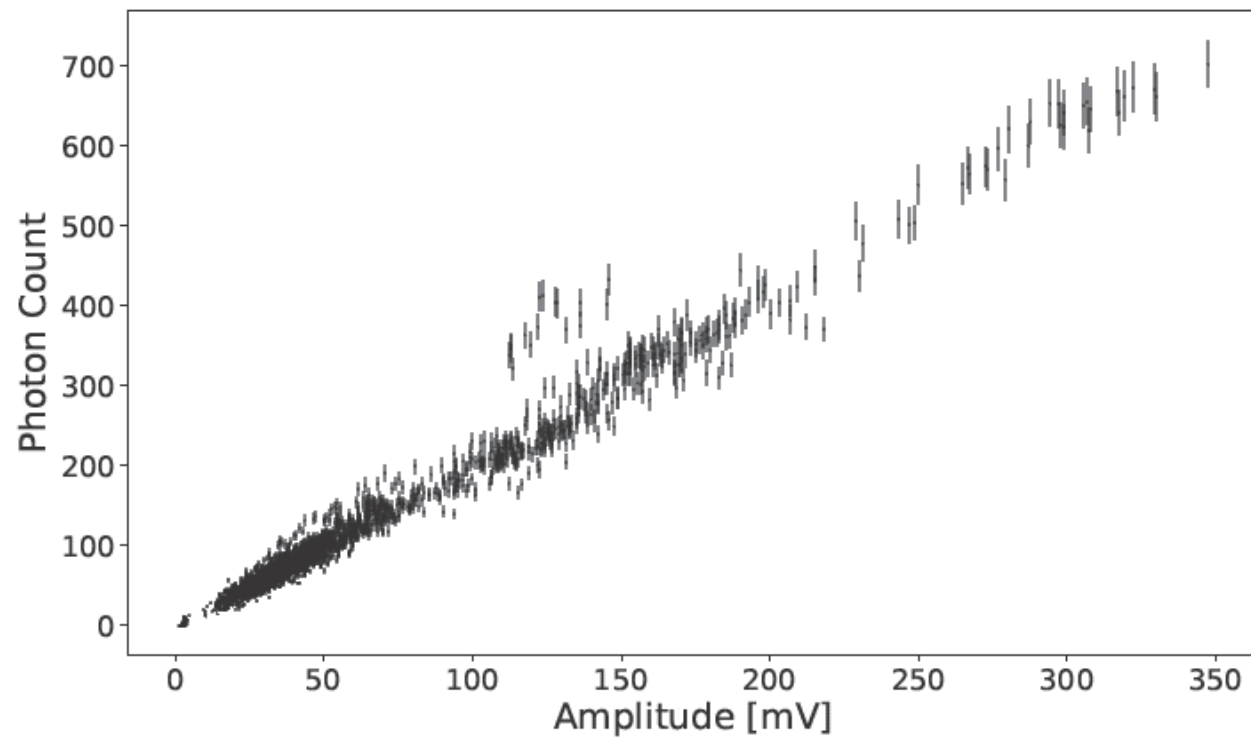
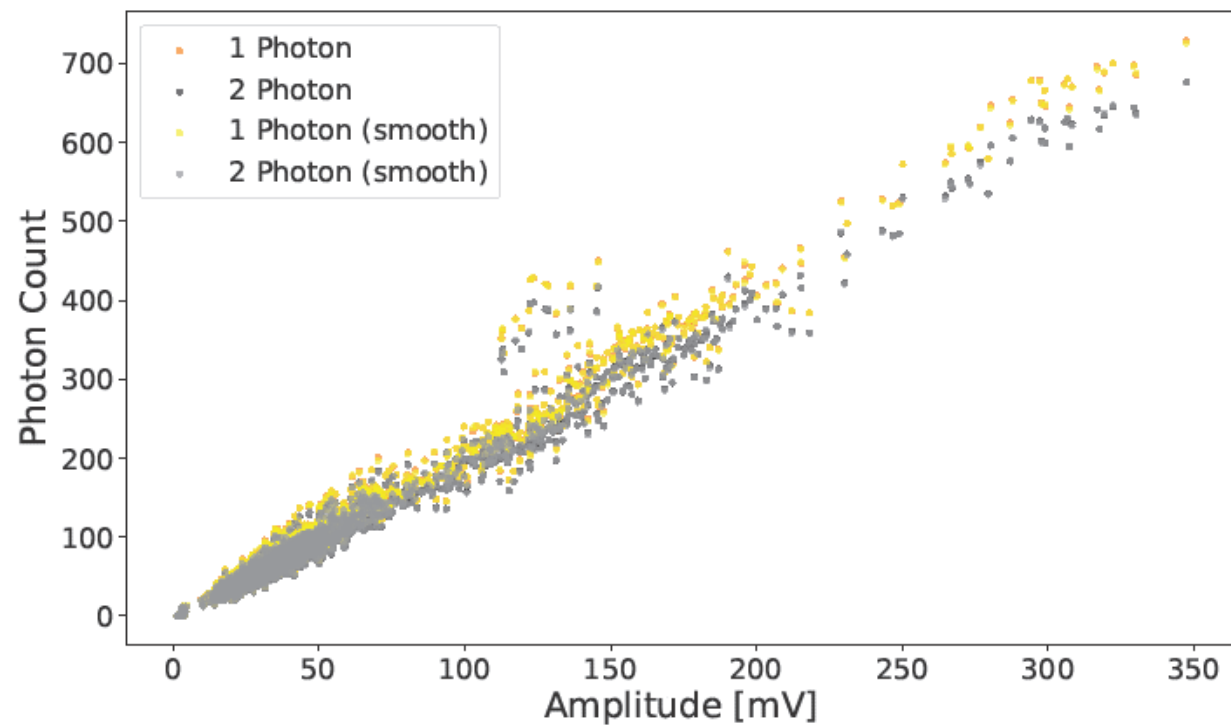

Integral over full WF:

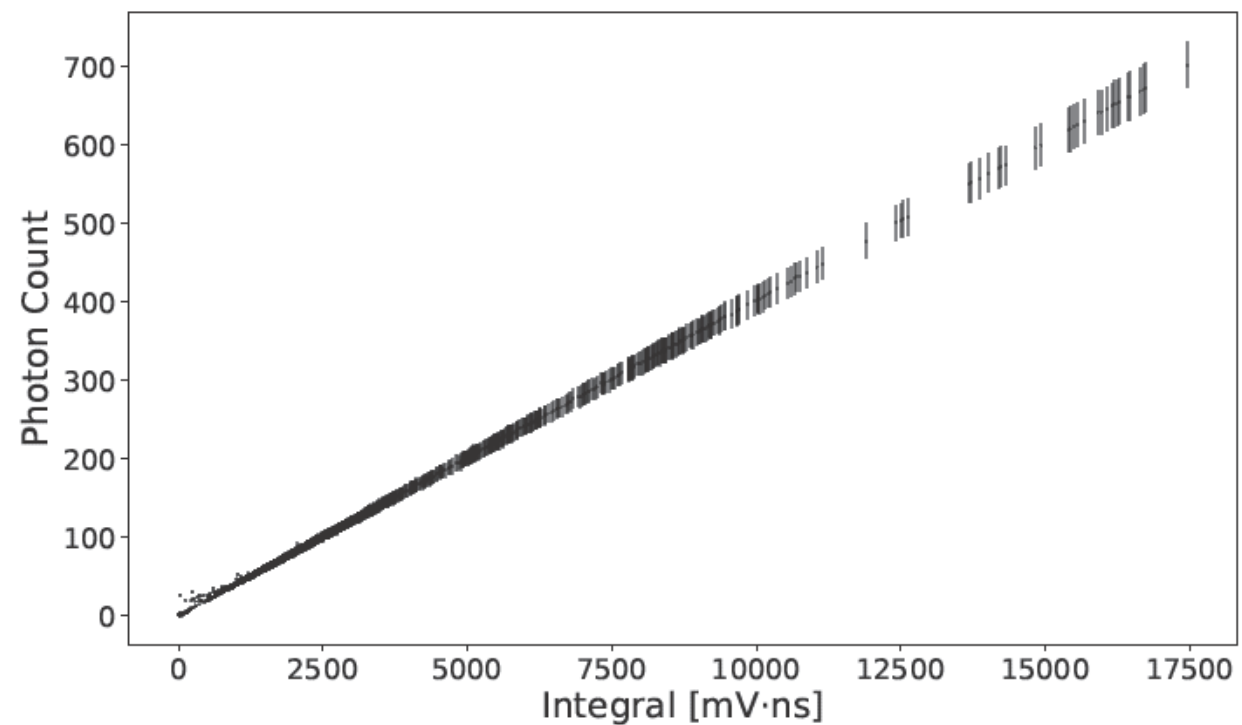
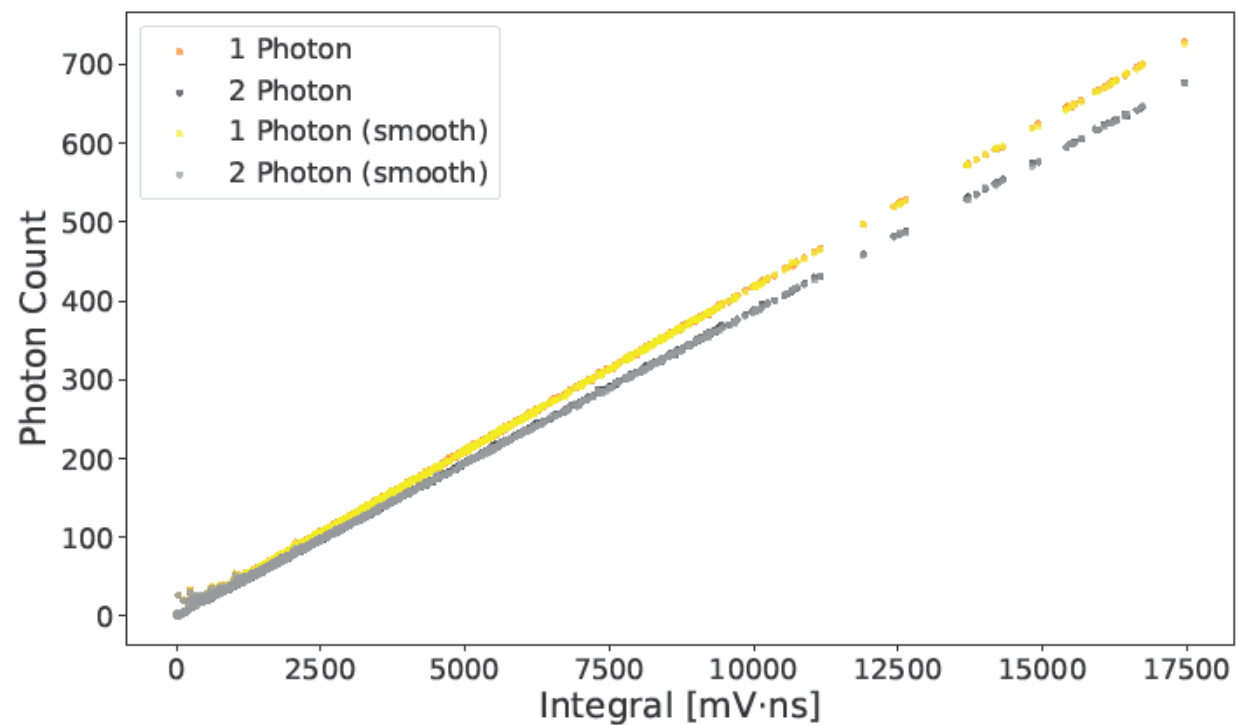

- Uncertainty: Spread of different templates

Integral over 120 ns integration window:

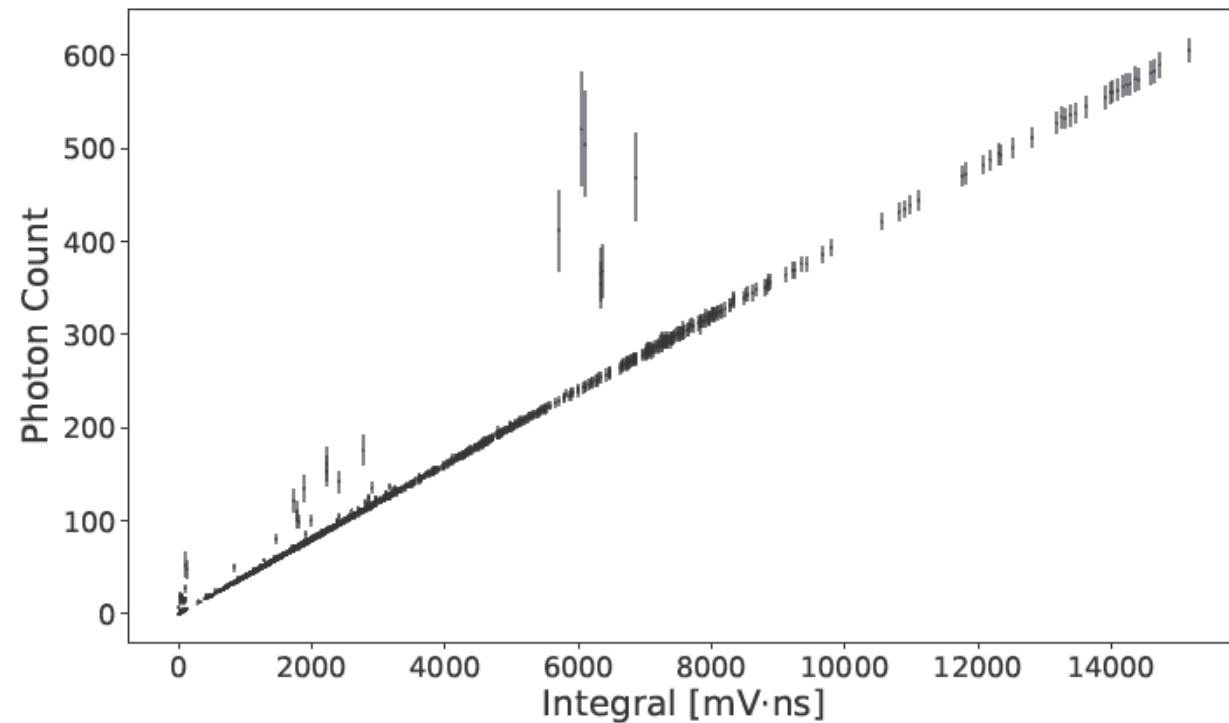
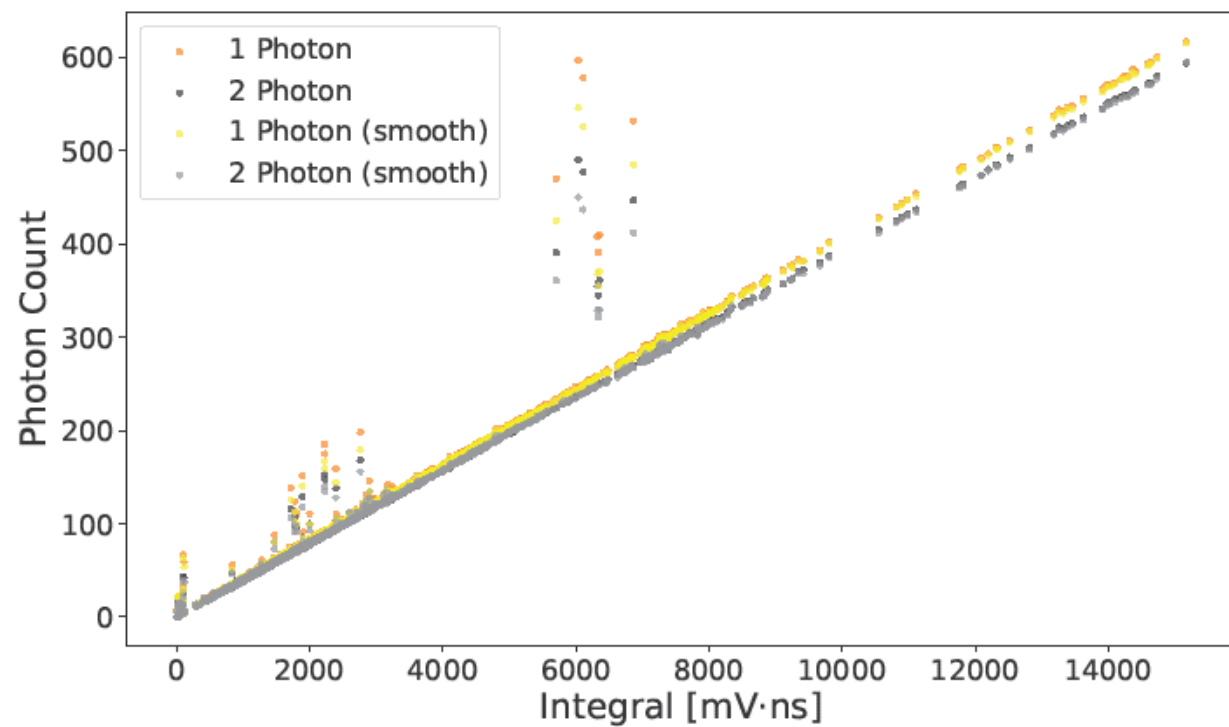
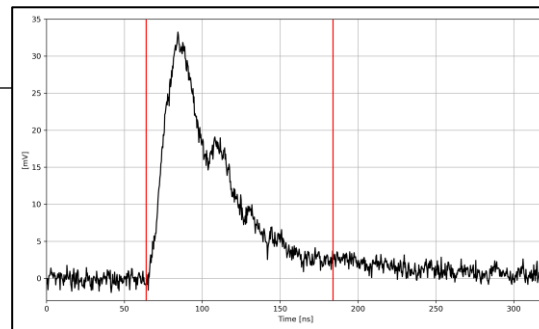

# Conclusion & Outlook

✔ Quantified detector response to low photon counts for parallel SiPM configurations using Dark Counts

✔ Created reconstruction algorithm for waveform modeling and template matching

✔ Identified candidate for signal characterisation: Integral over full waveform

➤ Confirmed for all four template types

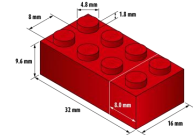
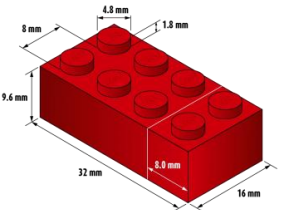

# Conclusion & Outlook

- ❑ For all changes in the electronics new templates will have to be determined
  - Reliable methodology essential
- ❑ SHiP plans to start data taking in 2033



Thank you for your time

Anne Sophie Müller

anne.mueller1@email.uni-freiburg.de  
Physikalisches Institut, Albert-Ludwigs-Universität Freiburg  
08.05.2026



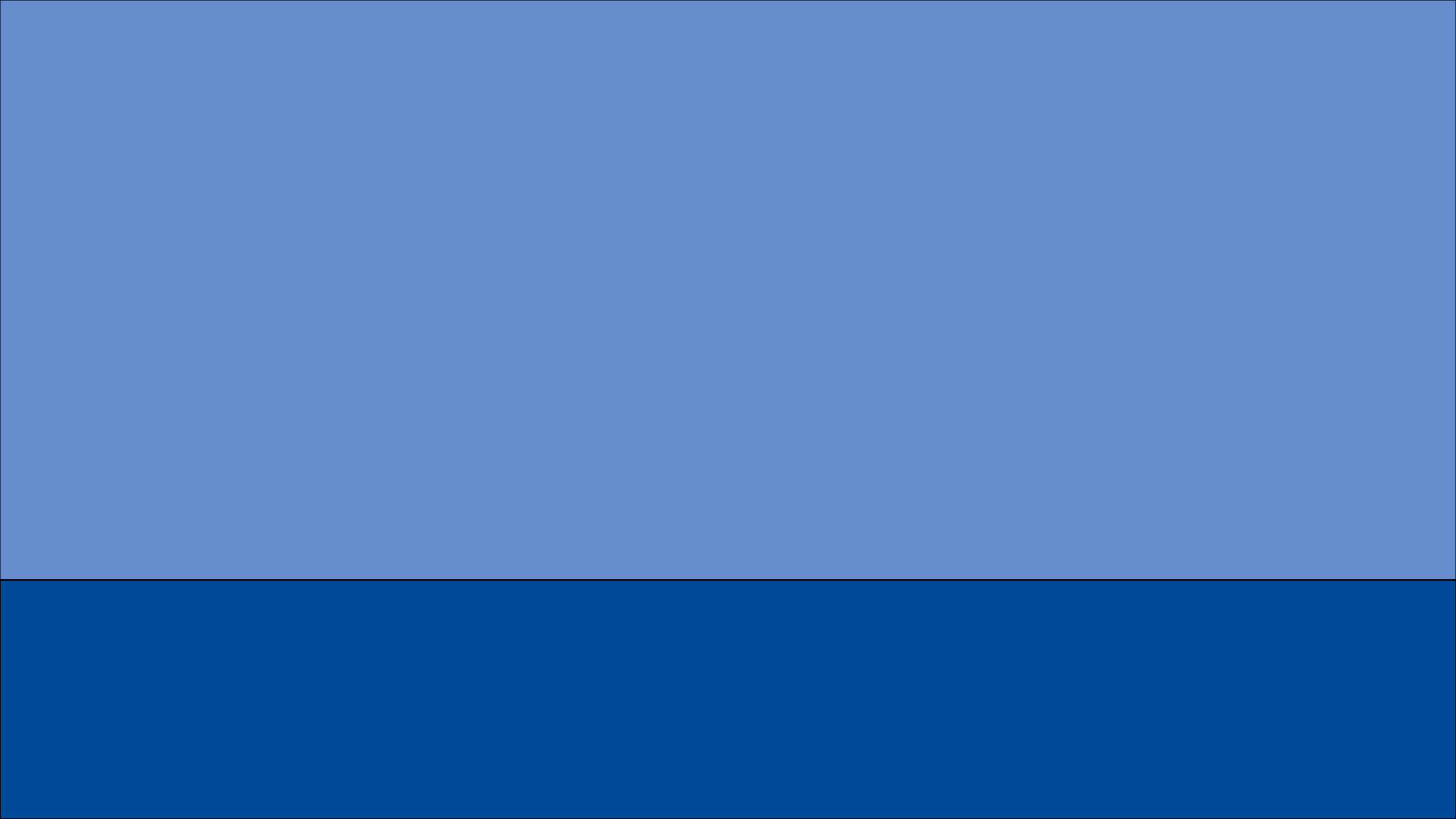

	Physics model	Final state
	SUSY neutralino	$l^\pm \pi^\mp, l^\pm K^\mp, l^\pm \rho^\mp, l^+ l^- \nu$
	Dark photons	$l^+ l^-, 2\pi, 3\pi, 4\pi, KK, q\bar{q}, D\bar{D}$
	Dark scalars	$ll, \pi\pi, KK, q\bar{q}, D\bar{D}, GG$
	ALP (fermion coupling)	$l^+ l^-, 3\pi, \eta\pi\pi, q\bar{q}$
HSDS	ALP (gluon coupling)	$\pi\pi\gamma, 3\pi, \eta\pi\pi, \gamma\gamma$
	HNL	$l^+ l'^- \nu, \pi l, \rho l, \pi^0 \nu, q\bar{q}' l$
	Axino	$l^+ l^- \nu$
	ALP (photon coupling)	$\gamma\gamma$
	SUSY sgoldstino	$\gamma\gamma, l^+ l^-, 2\pi, 2K$
	LDM	electron, proton, hadronic shower
SND	$\nu_\tau, \bar{\nu}_\tau$ measurements	$\tau^\pm$
	Neutrino-induced charm production ( $\nu_e, \nu_\mu, \nu_\tau$ )	$D_s^\pm, D^\pm, D^0, \bar{D}^0, \Lambda_c^+, \bar{\Lambda}_c^-$

# Signal Templates

## 1 Photon Template

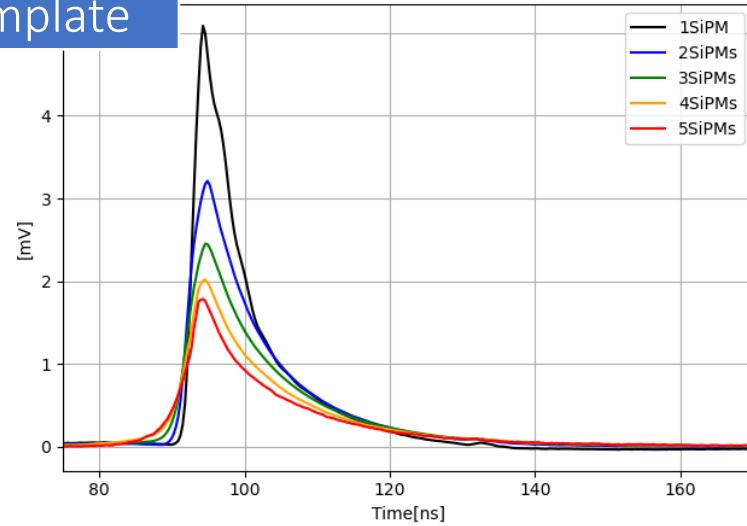

## 2 Photon Template

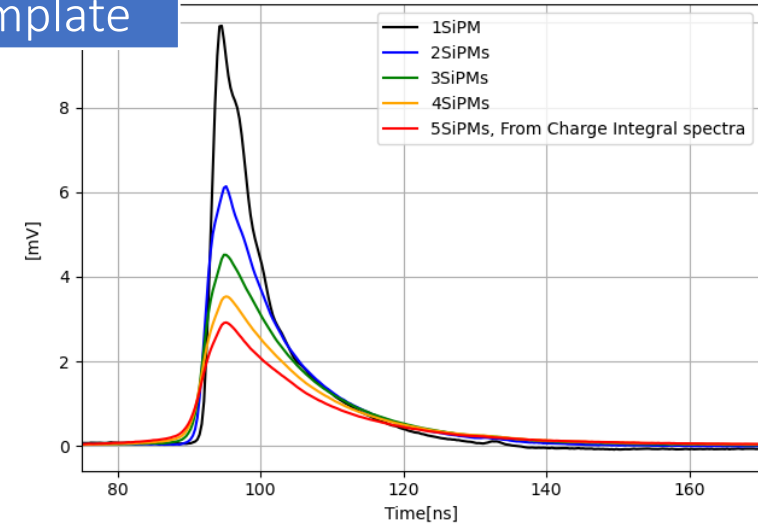

## 3 Photon Template

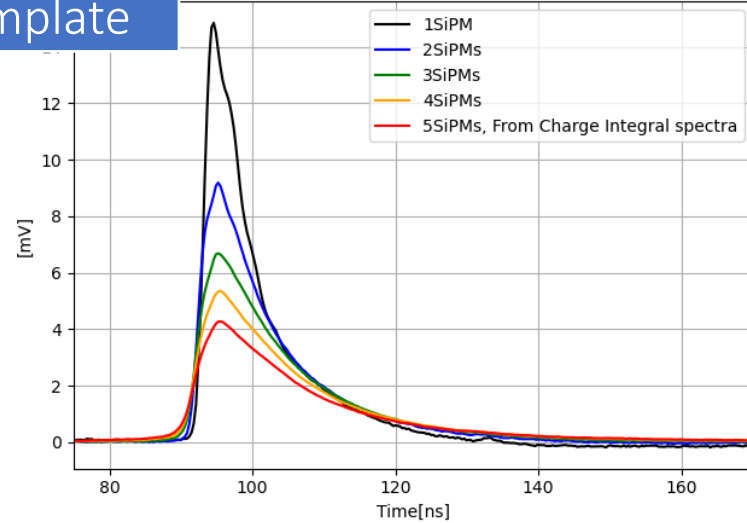

## 4 Photon Template

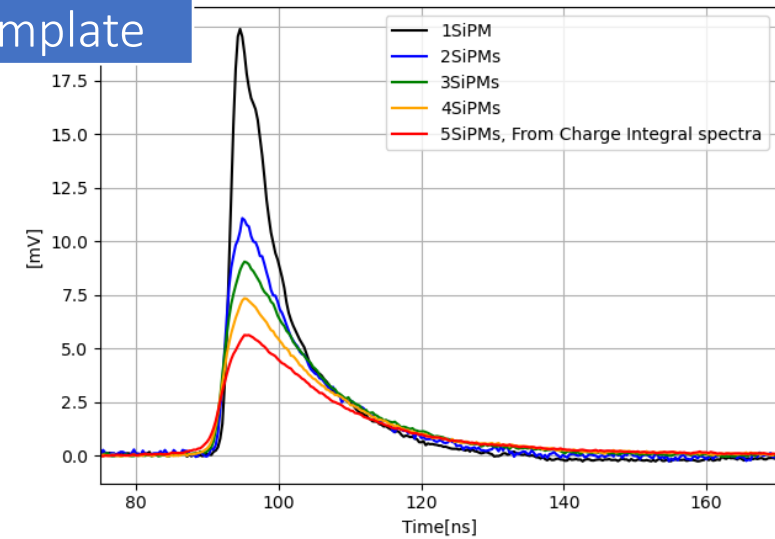

# Results

### Stdev vs Mean of Photon Count

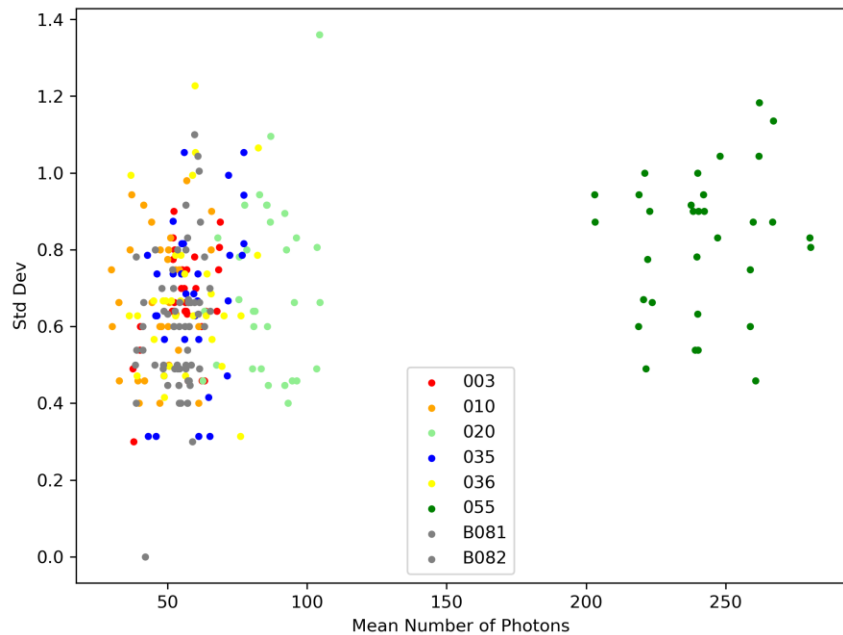

### Standard Error of Mean (SEM) vs Mean Photon Count

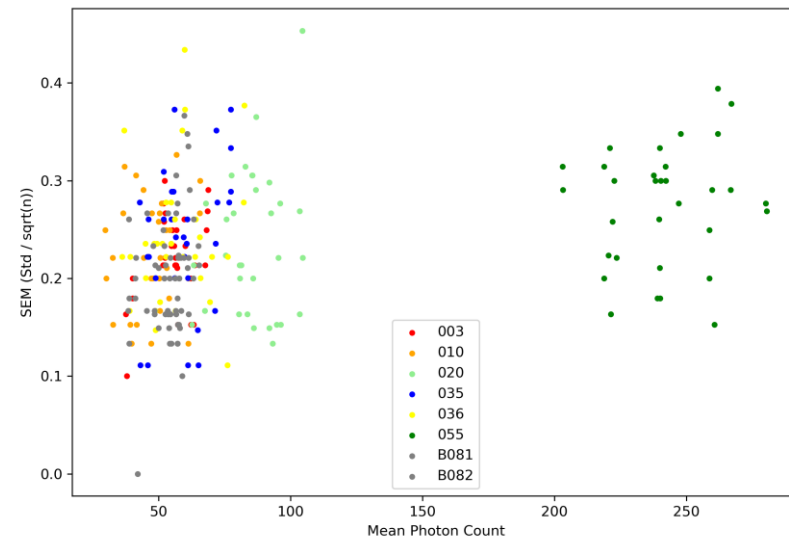

### Relative Standard Deviation (RSD) vs Mean Photon Count

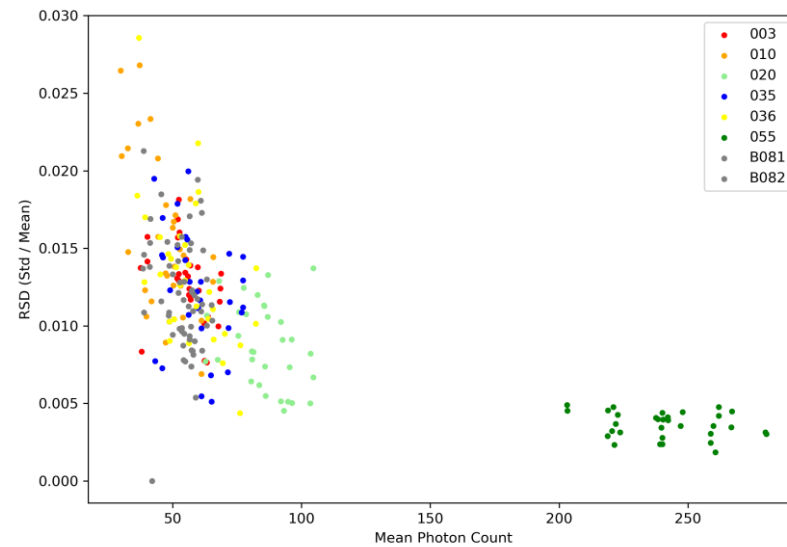

# Results

Integral over full WF:

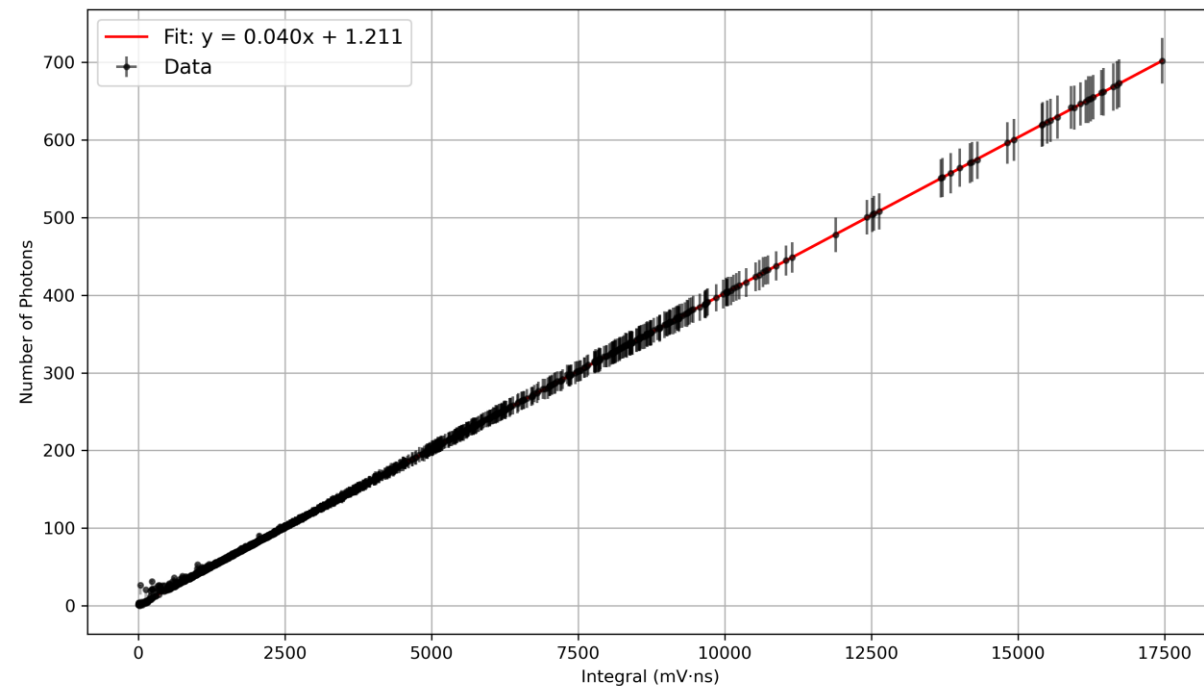
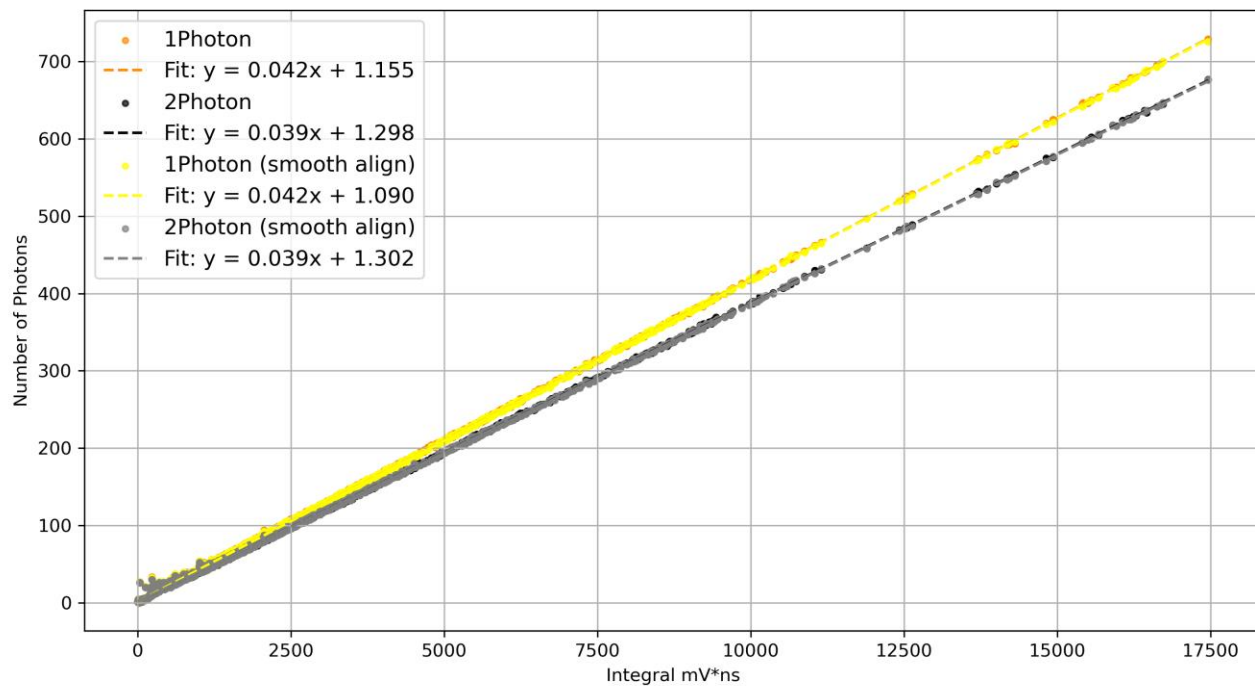

# Results

Integral over 120 ns integration window:

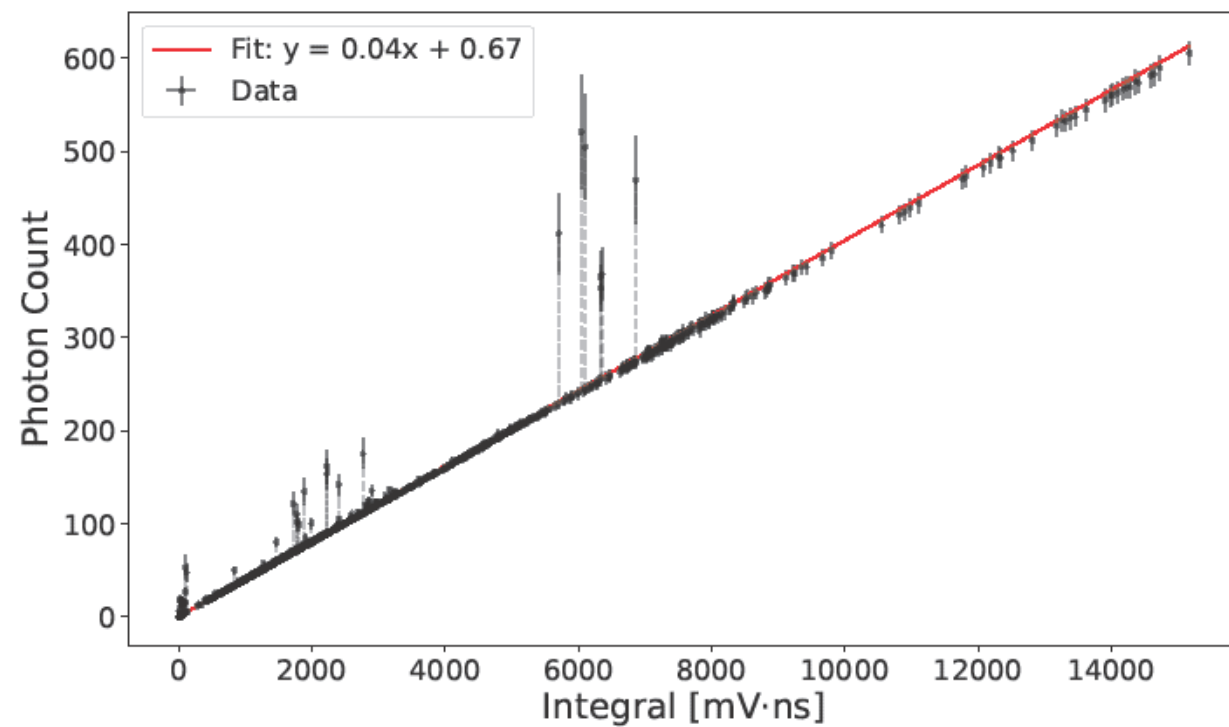
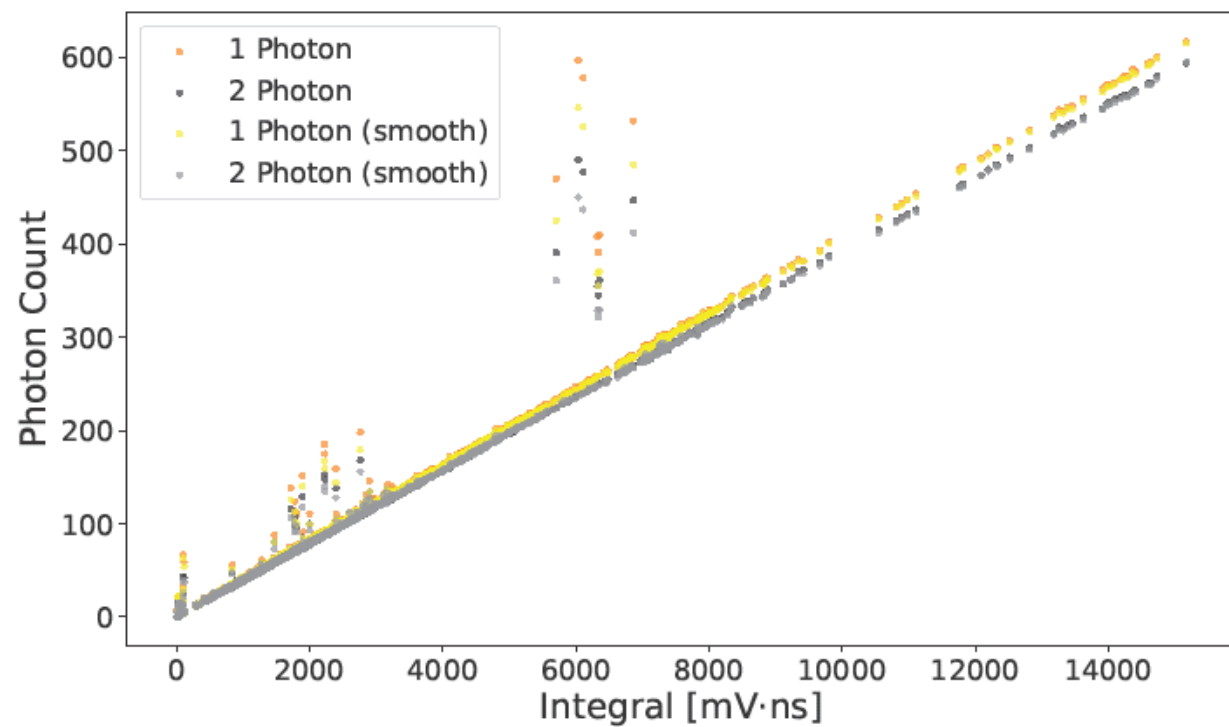
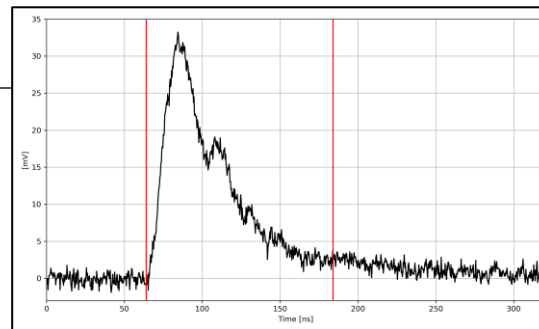

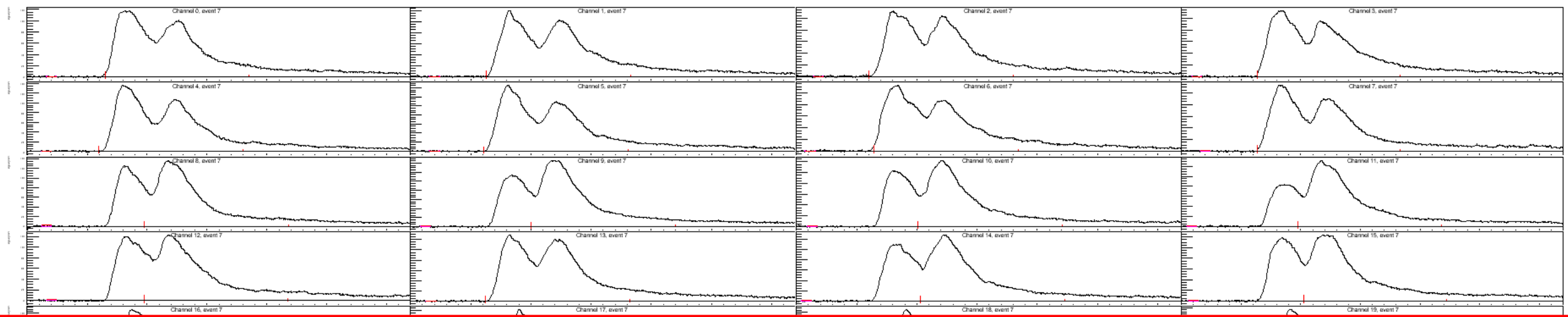

Amplitude of WF:

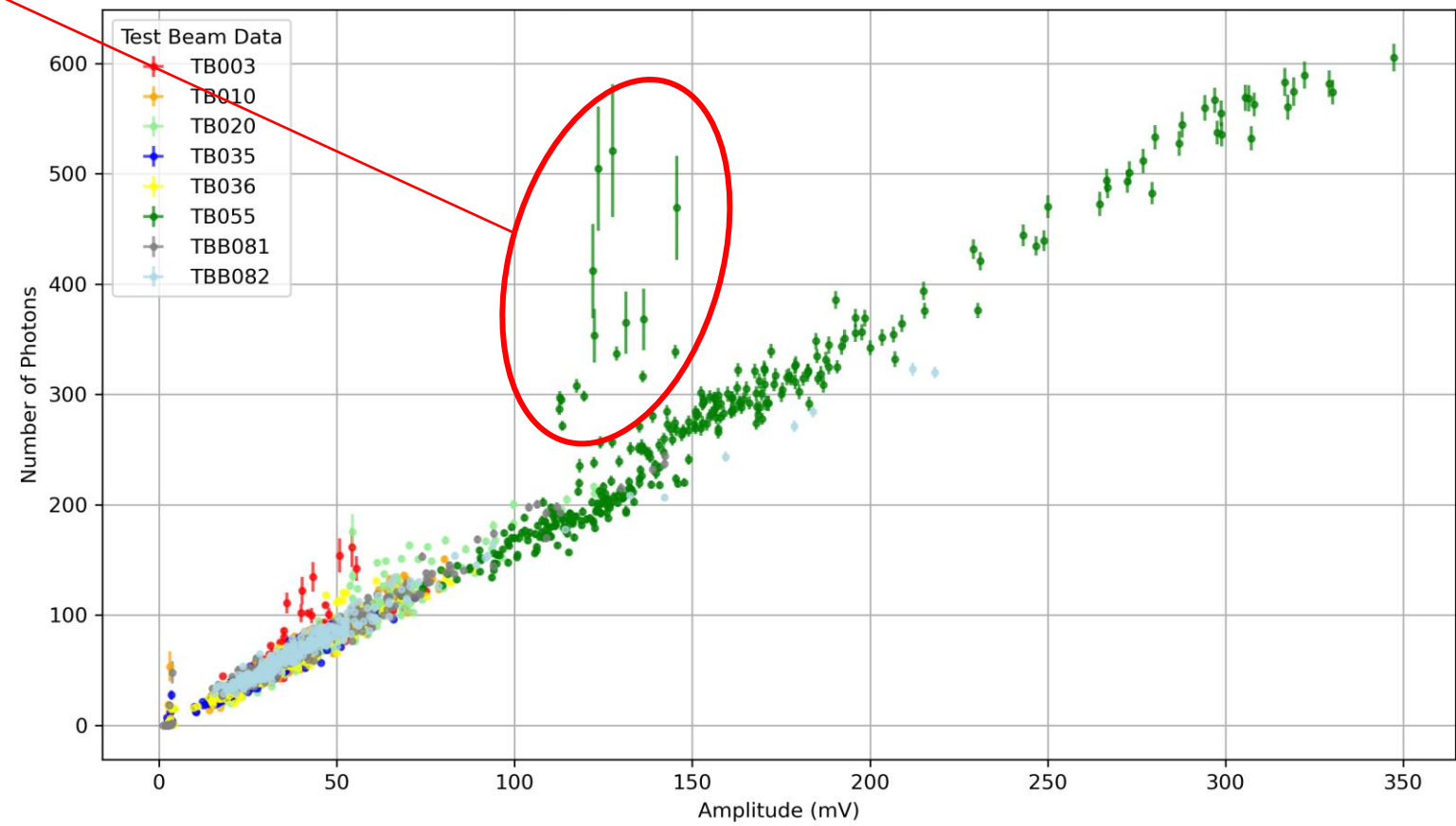

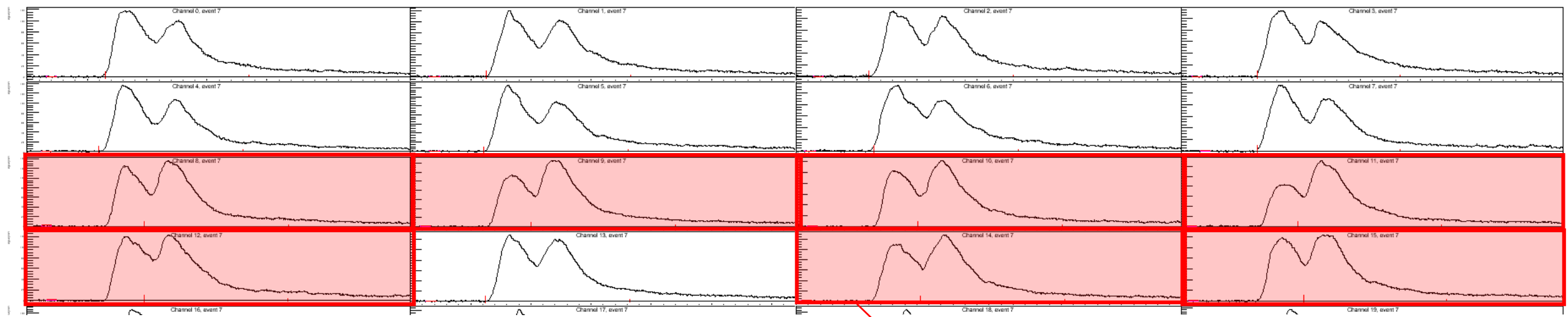

Integral over 120ns integration window:

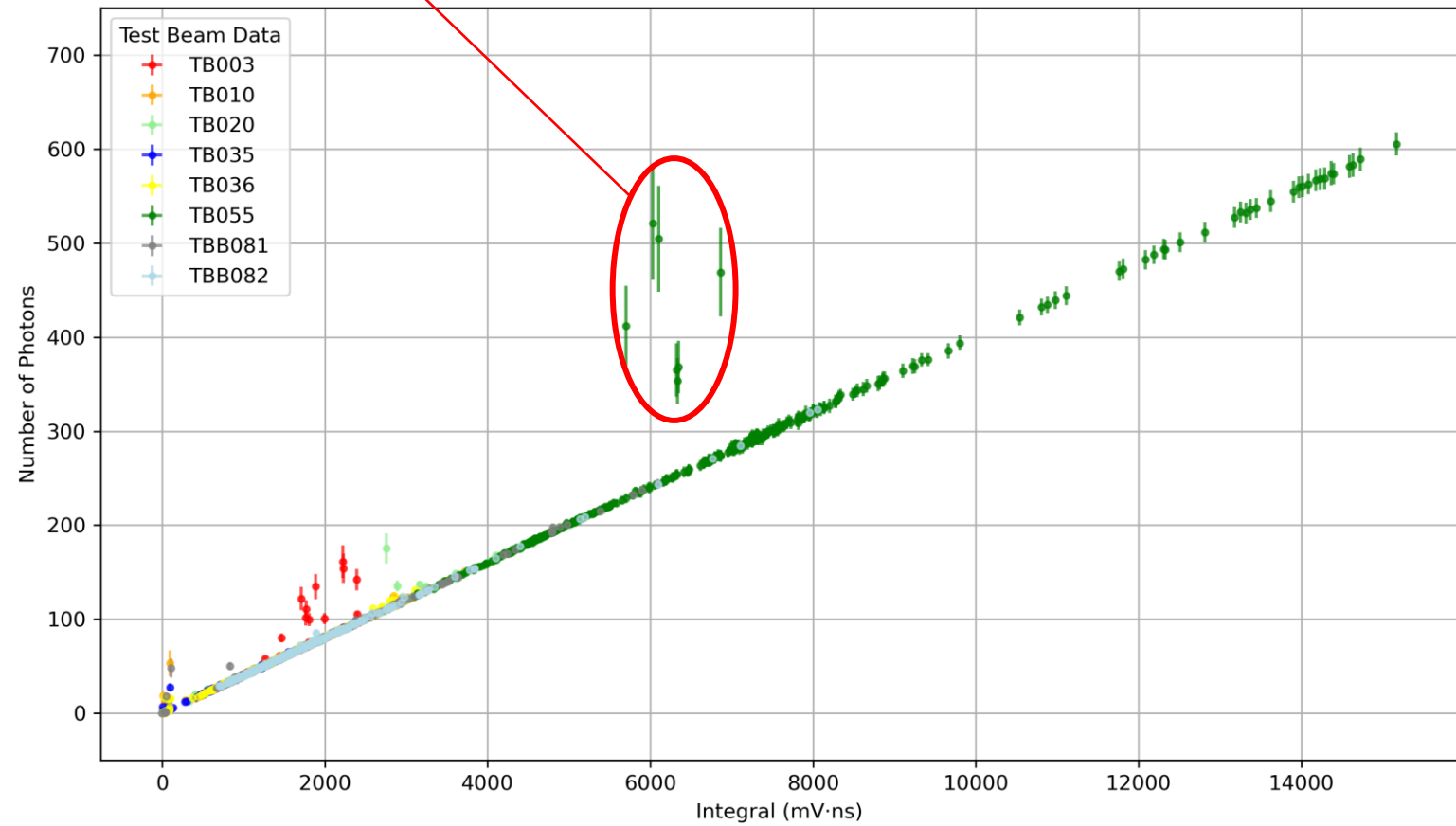

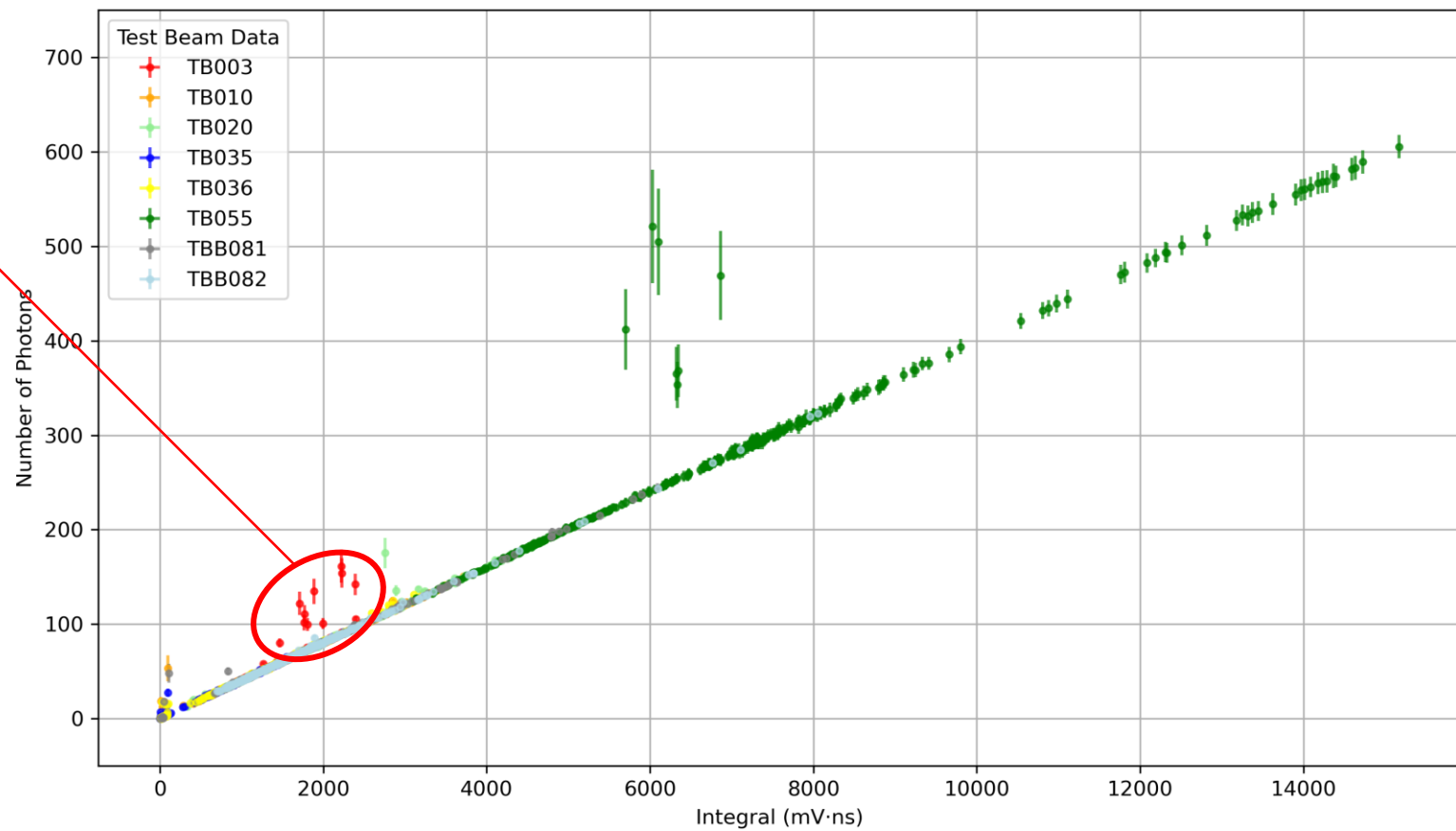
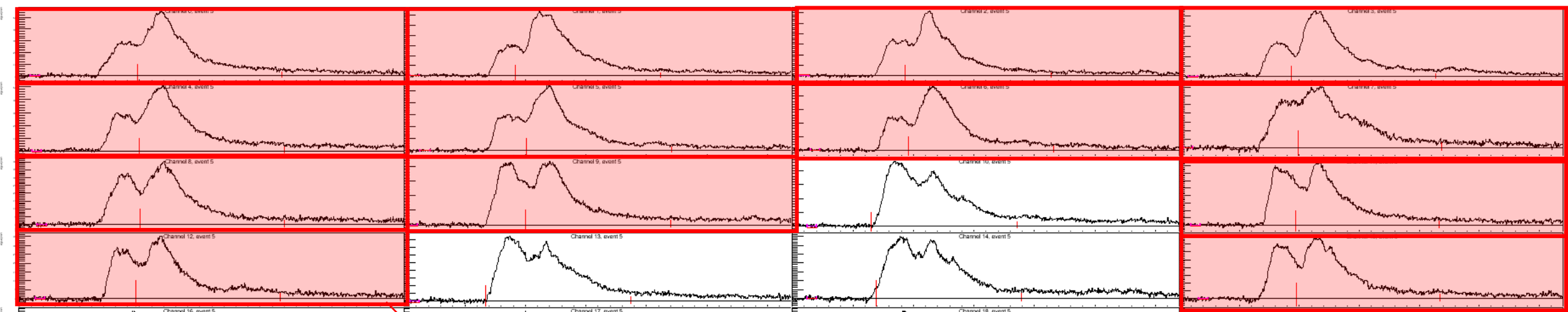

LASER setup, Freiburg:

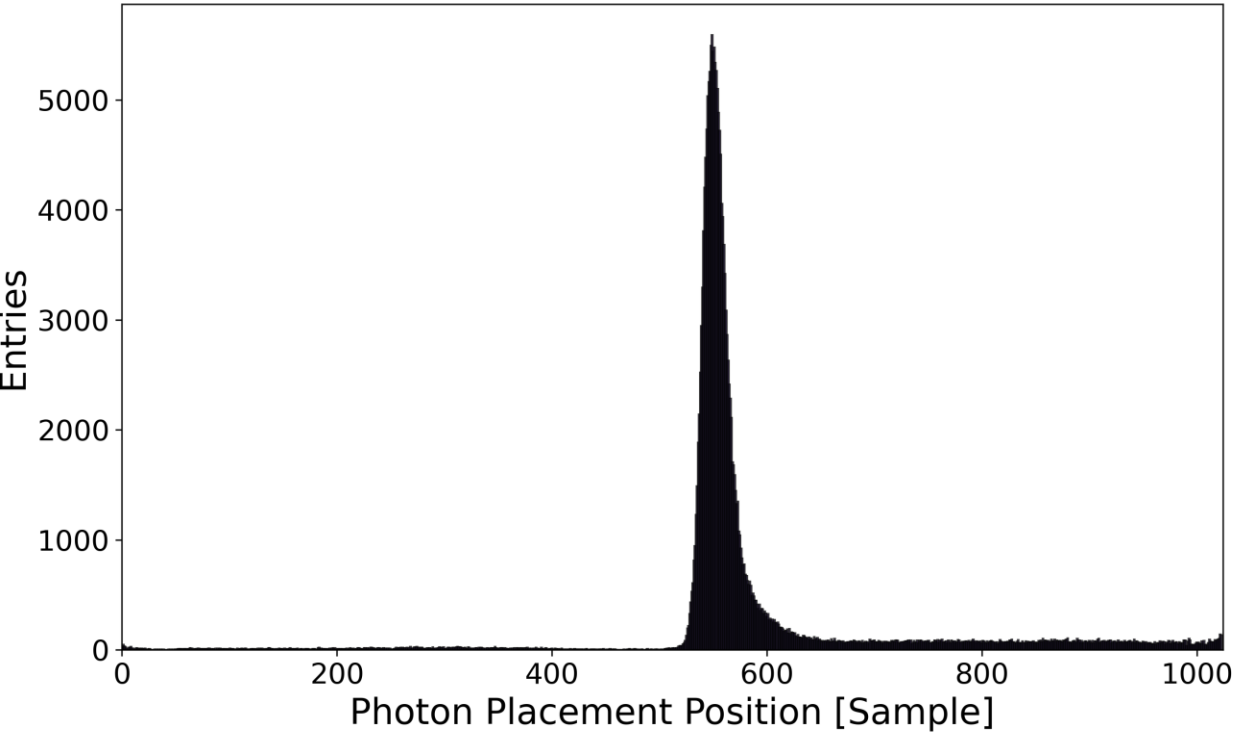

TB May 2025, Origin shot:

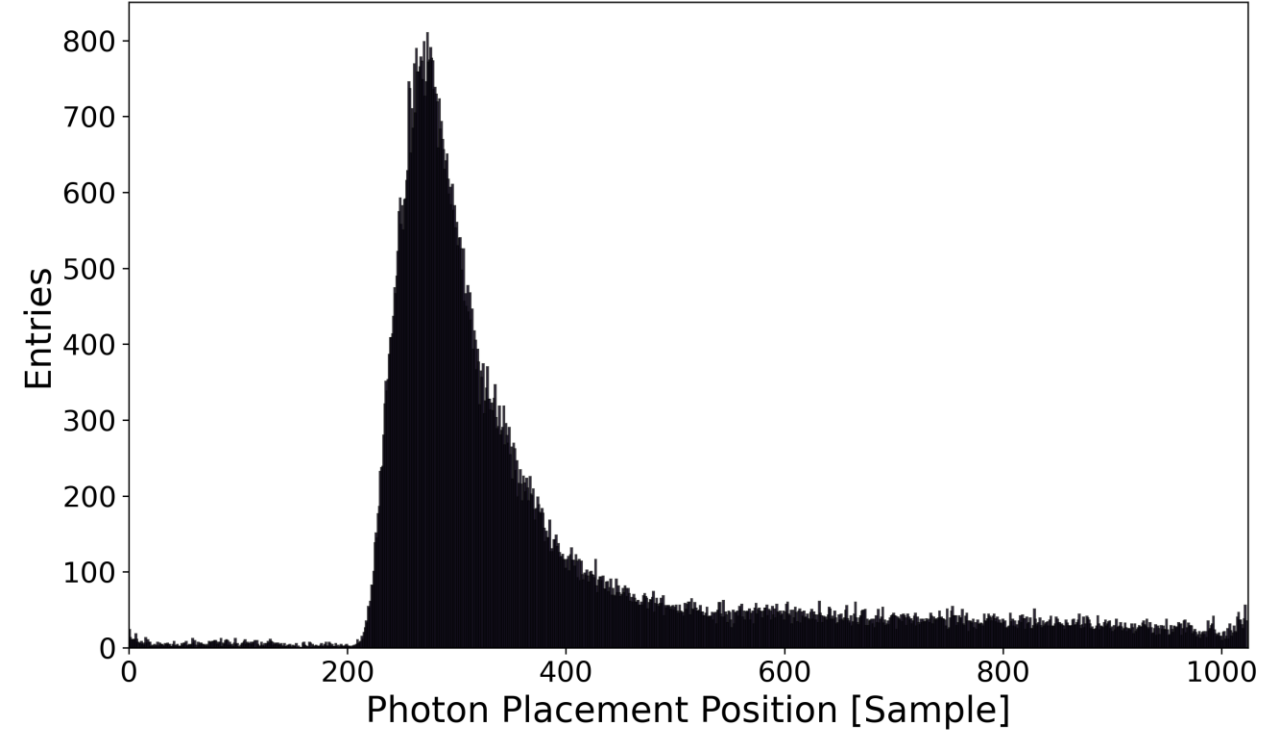

LASER setup, Freiburg:

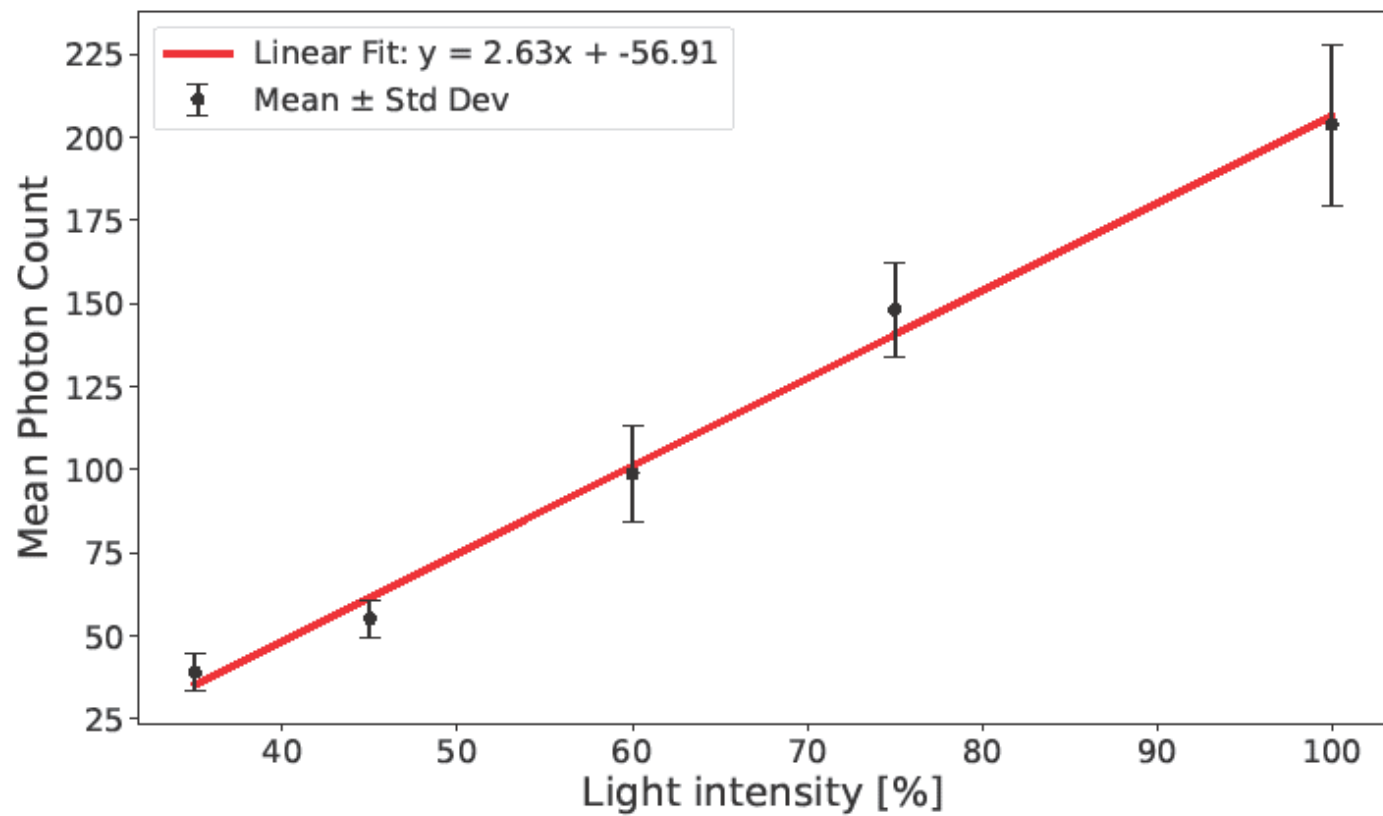

Template addition at different positions:

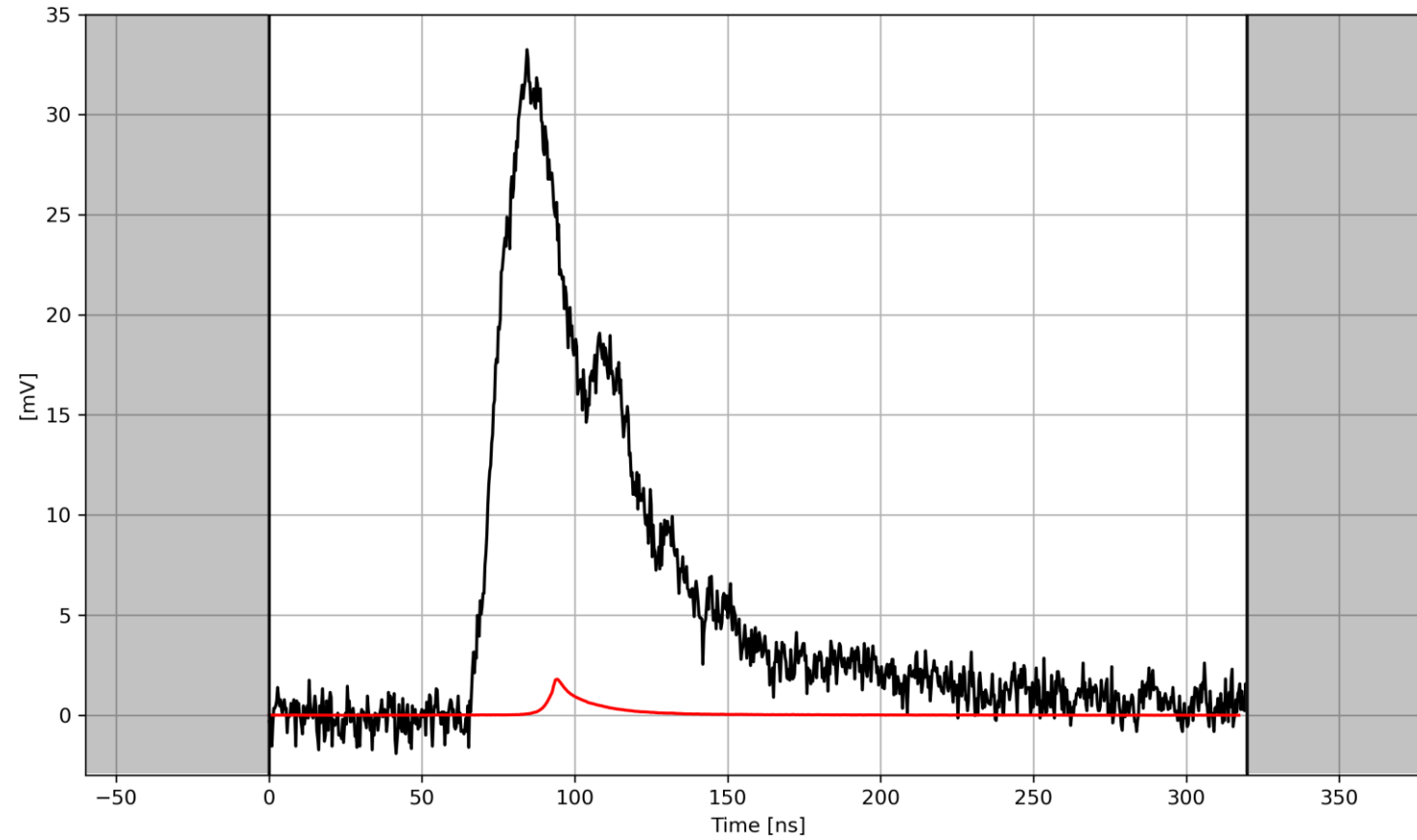

Template addition at different positions:

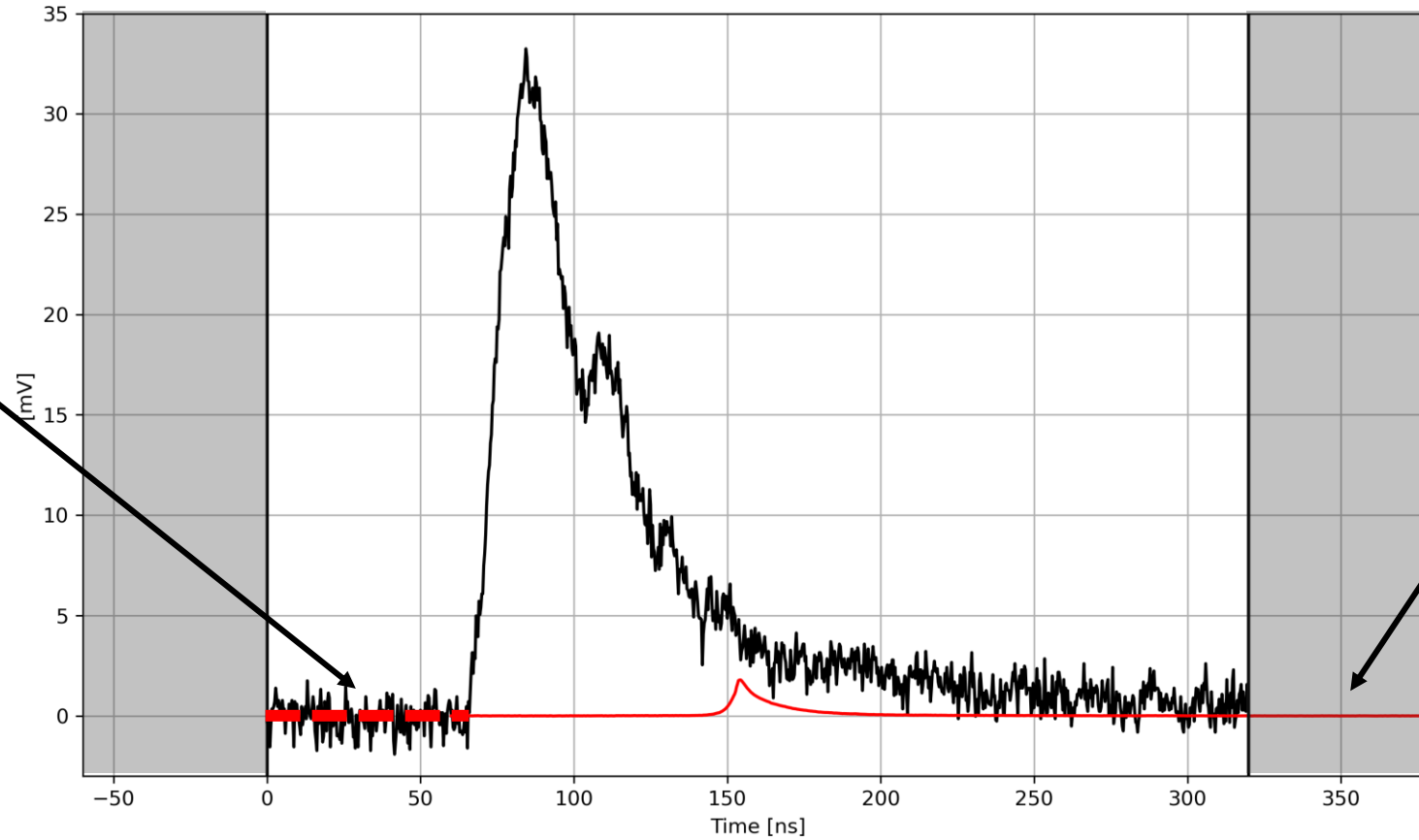

Place zeros at the beginning

Cut off

Template addition at different positions:

Cut off

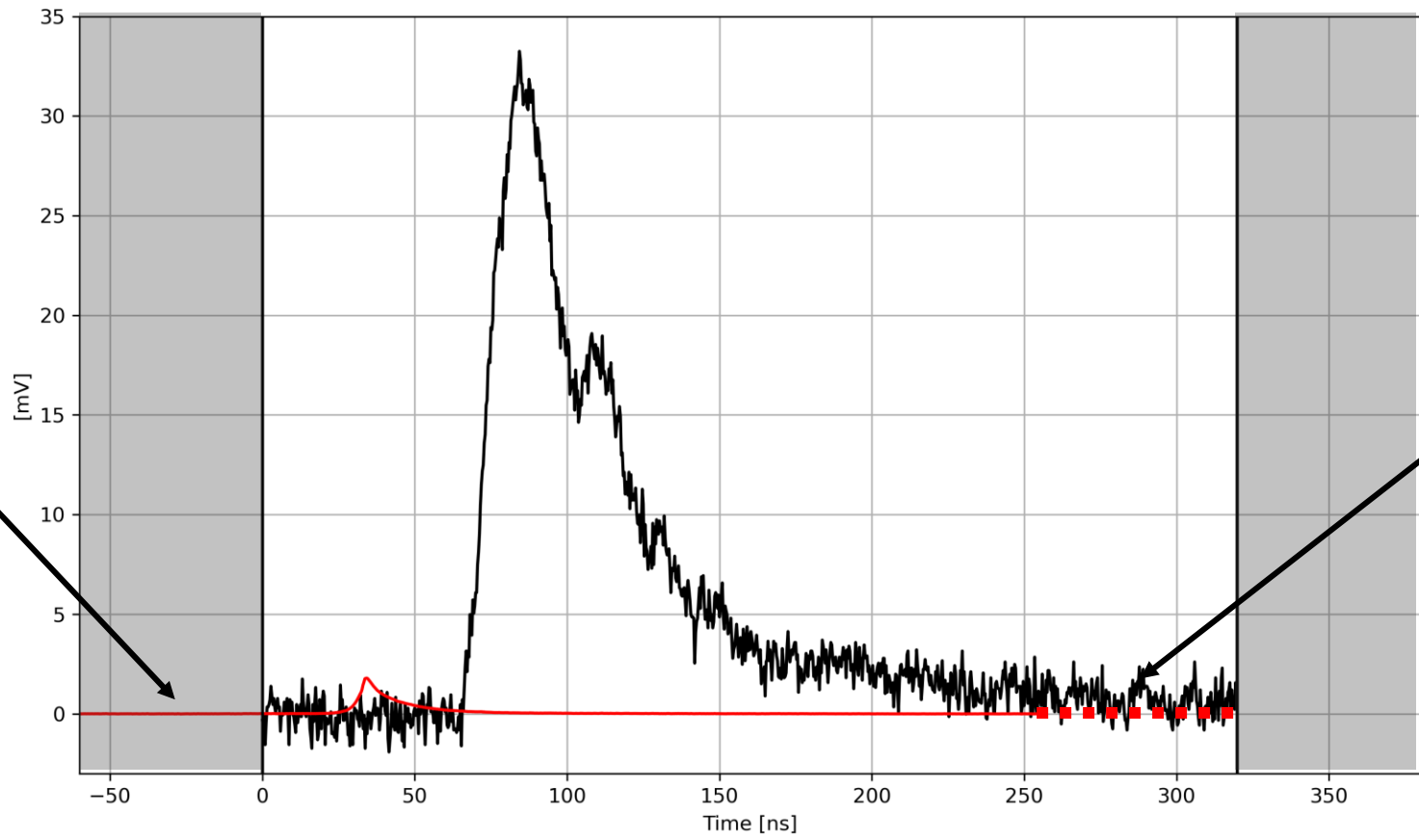

Place zeros at the end



Mean over 100WFs, 1SiPM, channel1

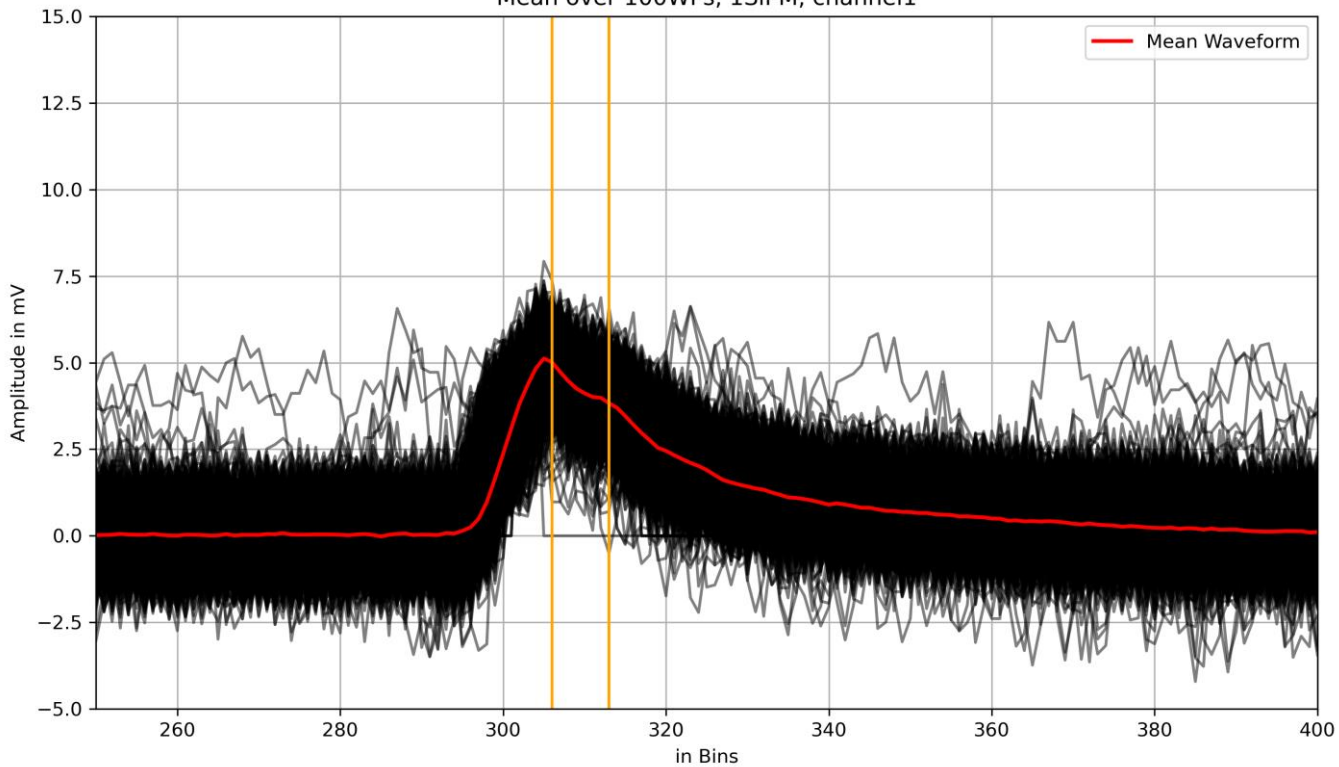

Waveform Heatmap, 1SiPMs Channel1

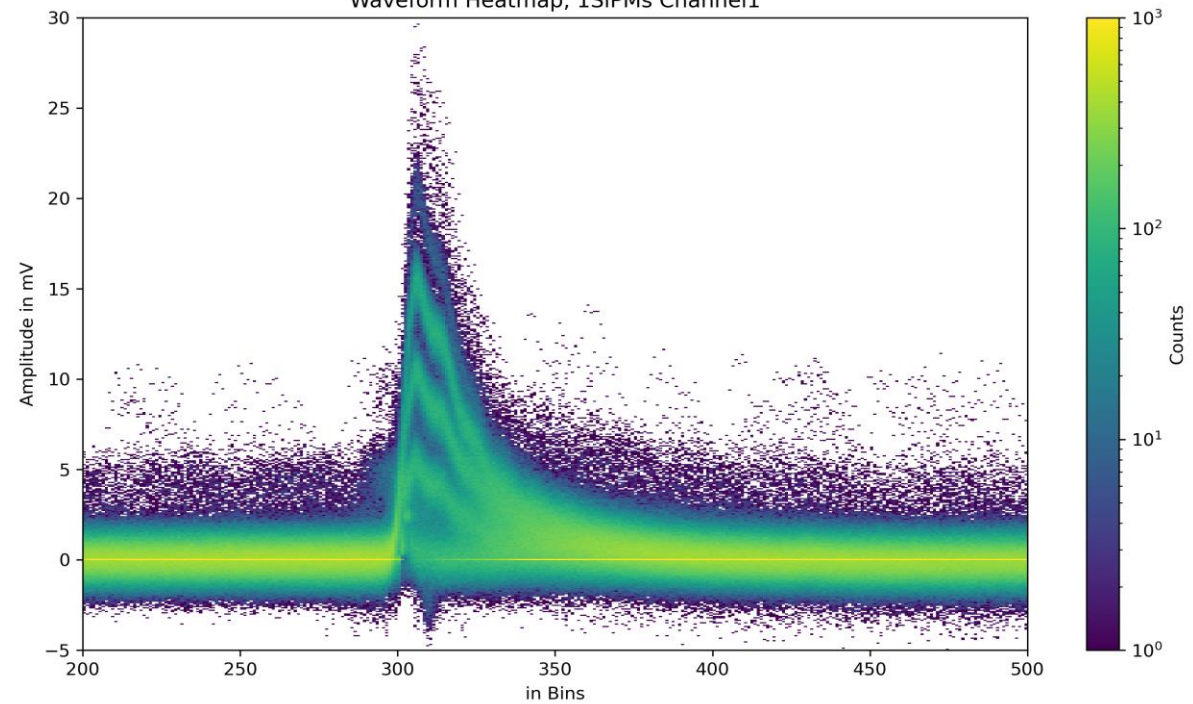

Mean over 100WFs, 1SiPM, channel1

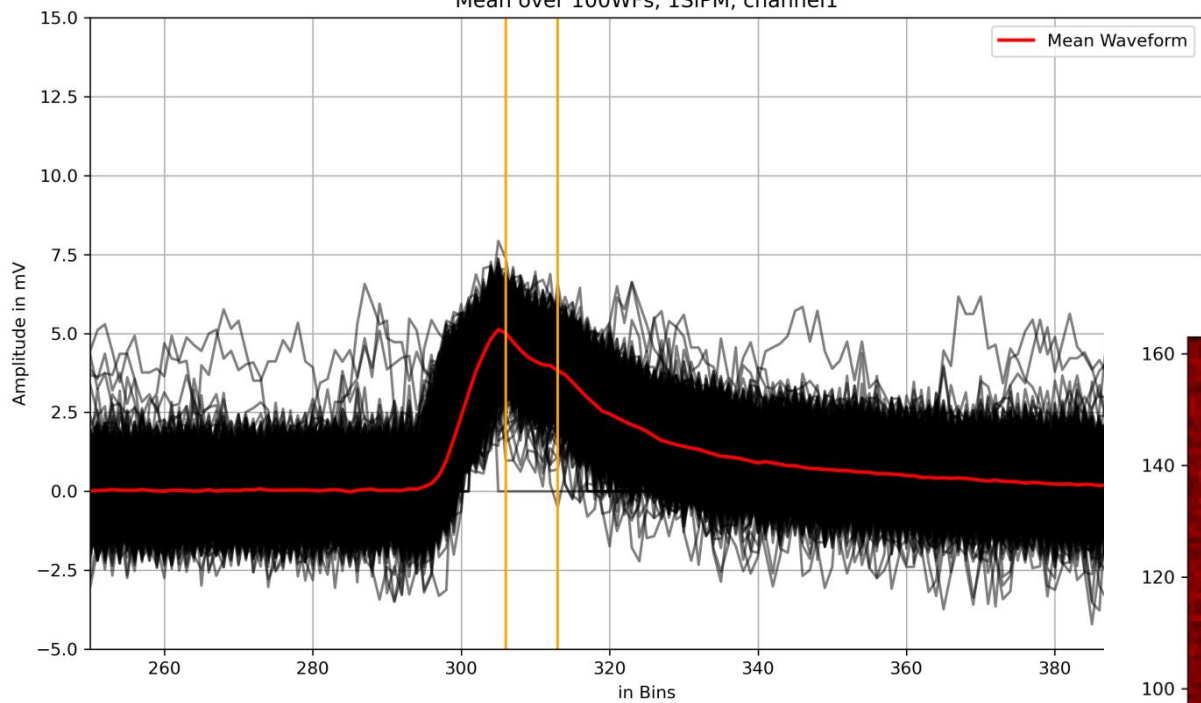

Waveform Overview Heatmap, 1SiPMs Channel1

