

Does the Higgs boson wear a Mexican-hat?

Brian Moser (University of Freiburg)

Oxford Particle Physics Seminar

14/05/2026



universität freiburg

Image created with Midjourney

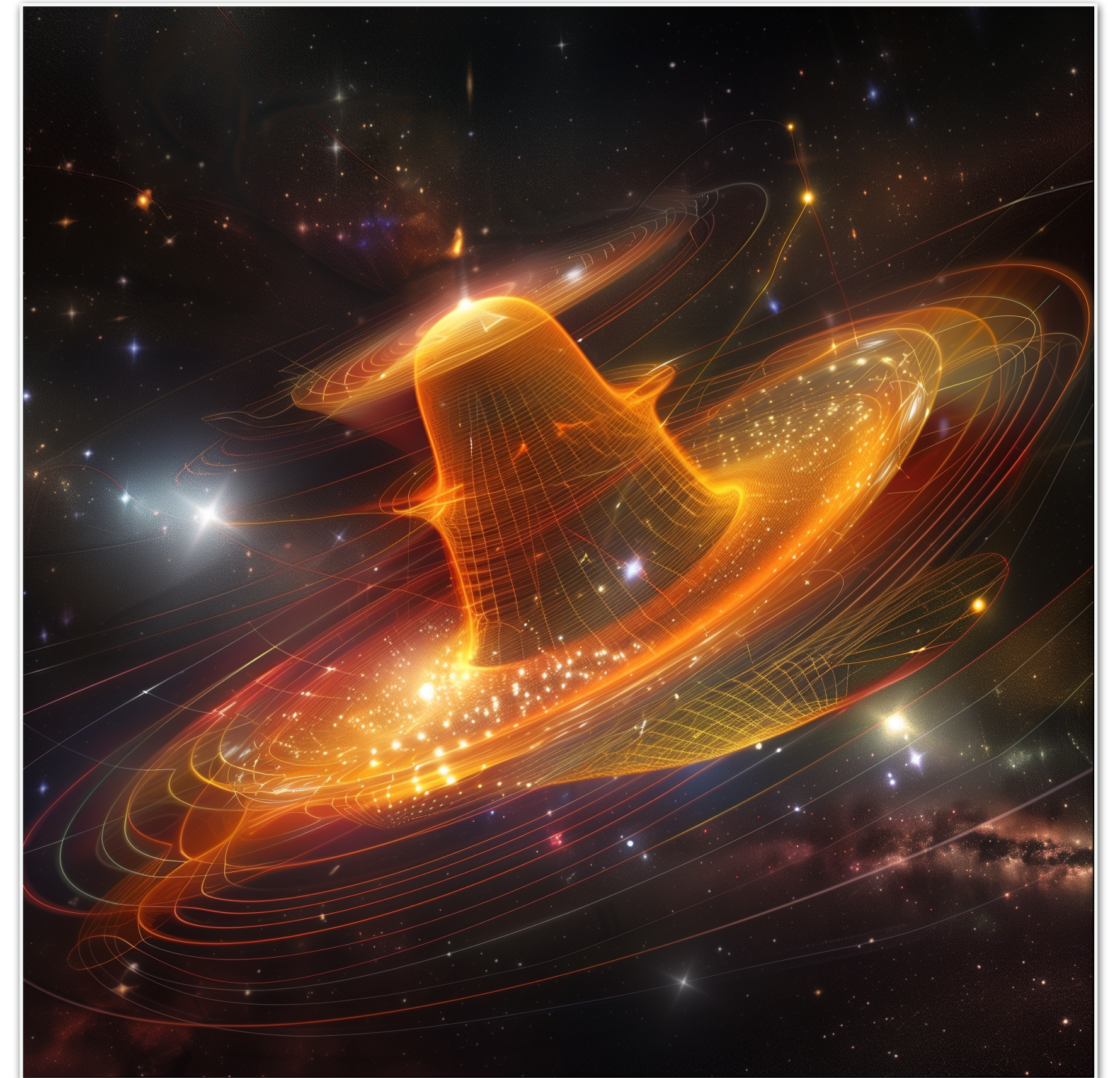

A cautionary tale about insufficient resolution

Giovanni Schiaparelli

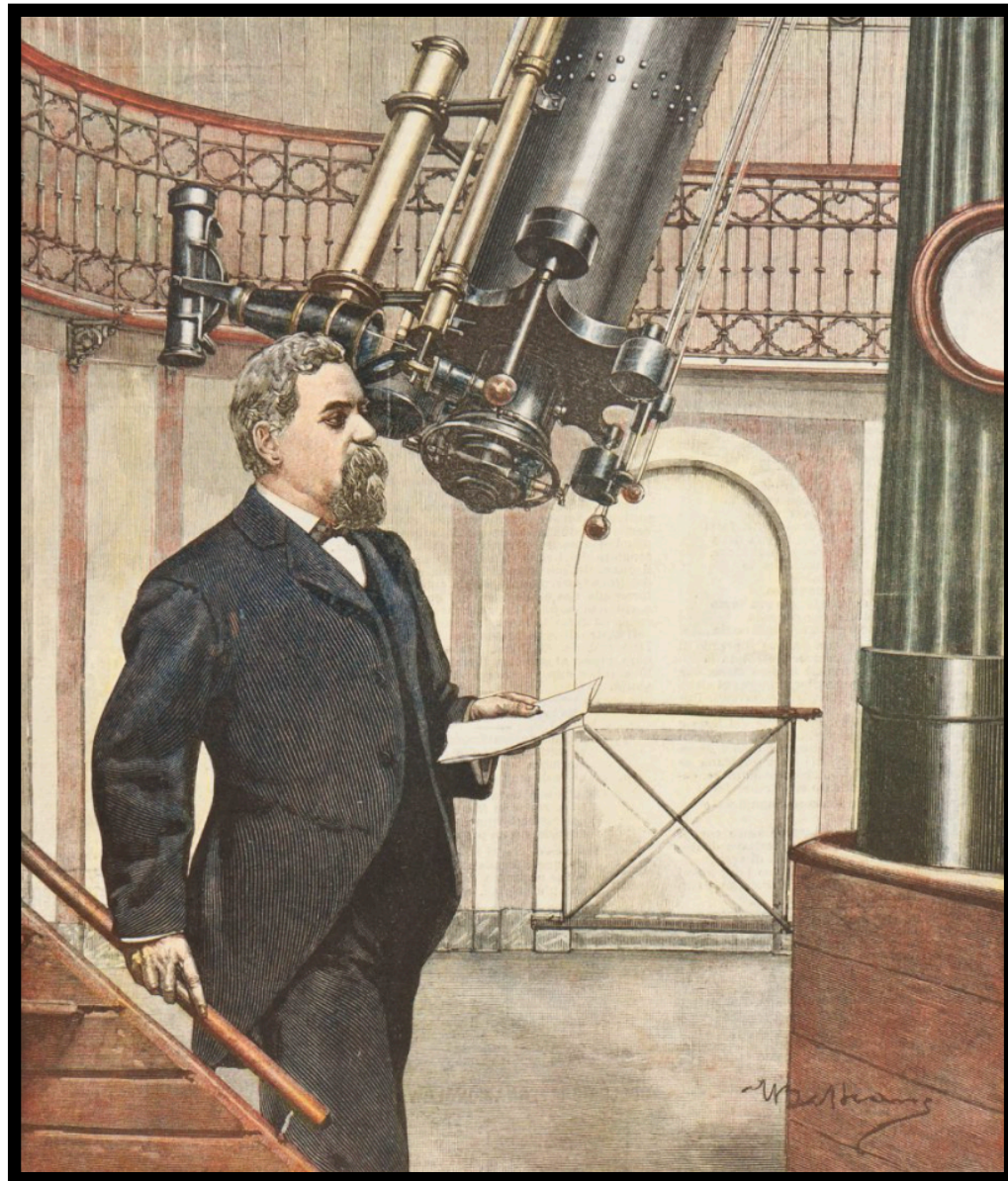

Late 19th century

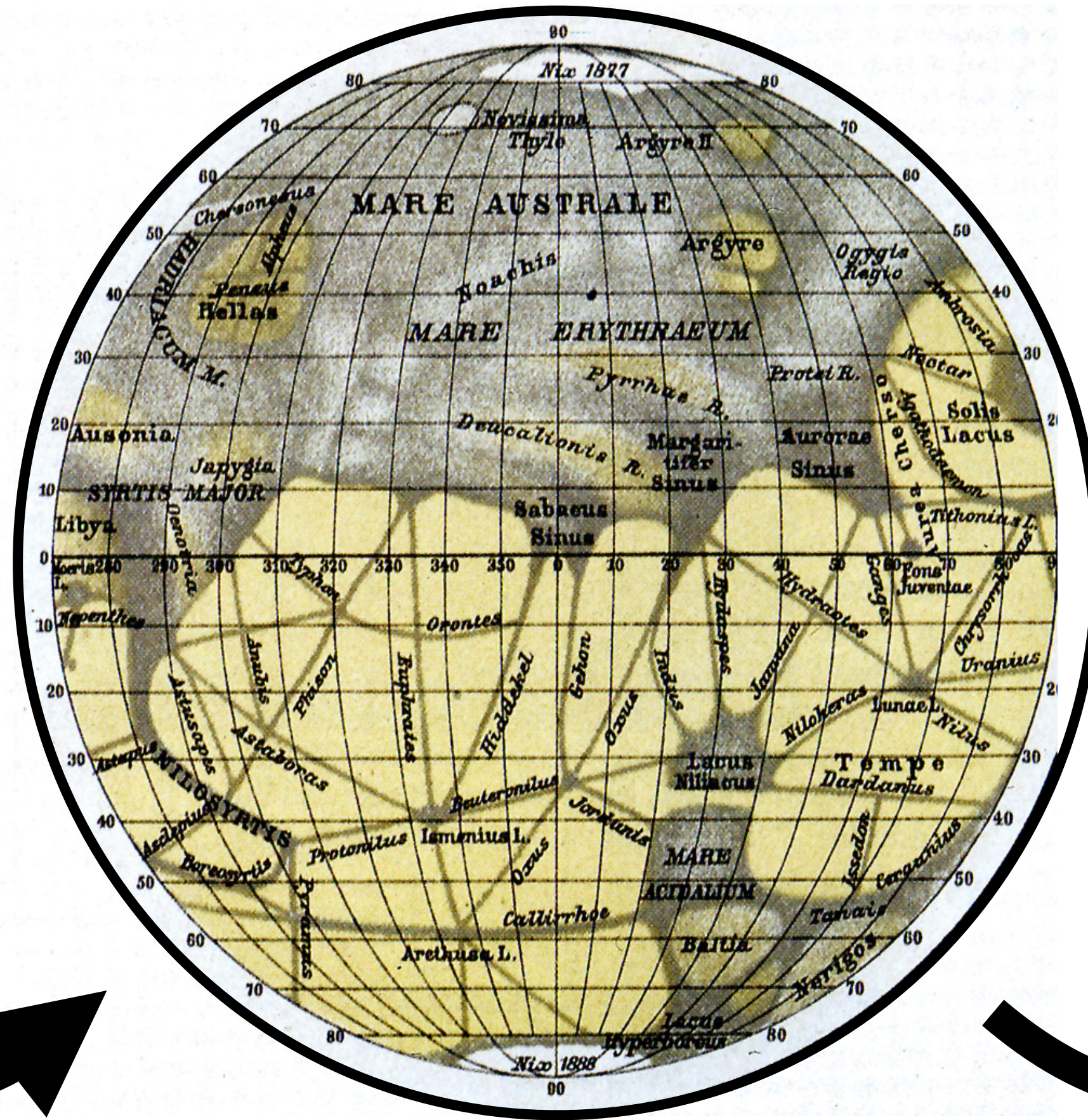

Canals on Mars?

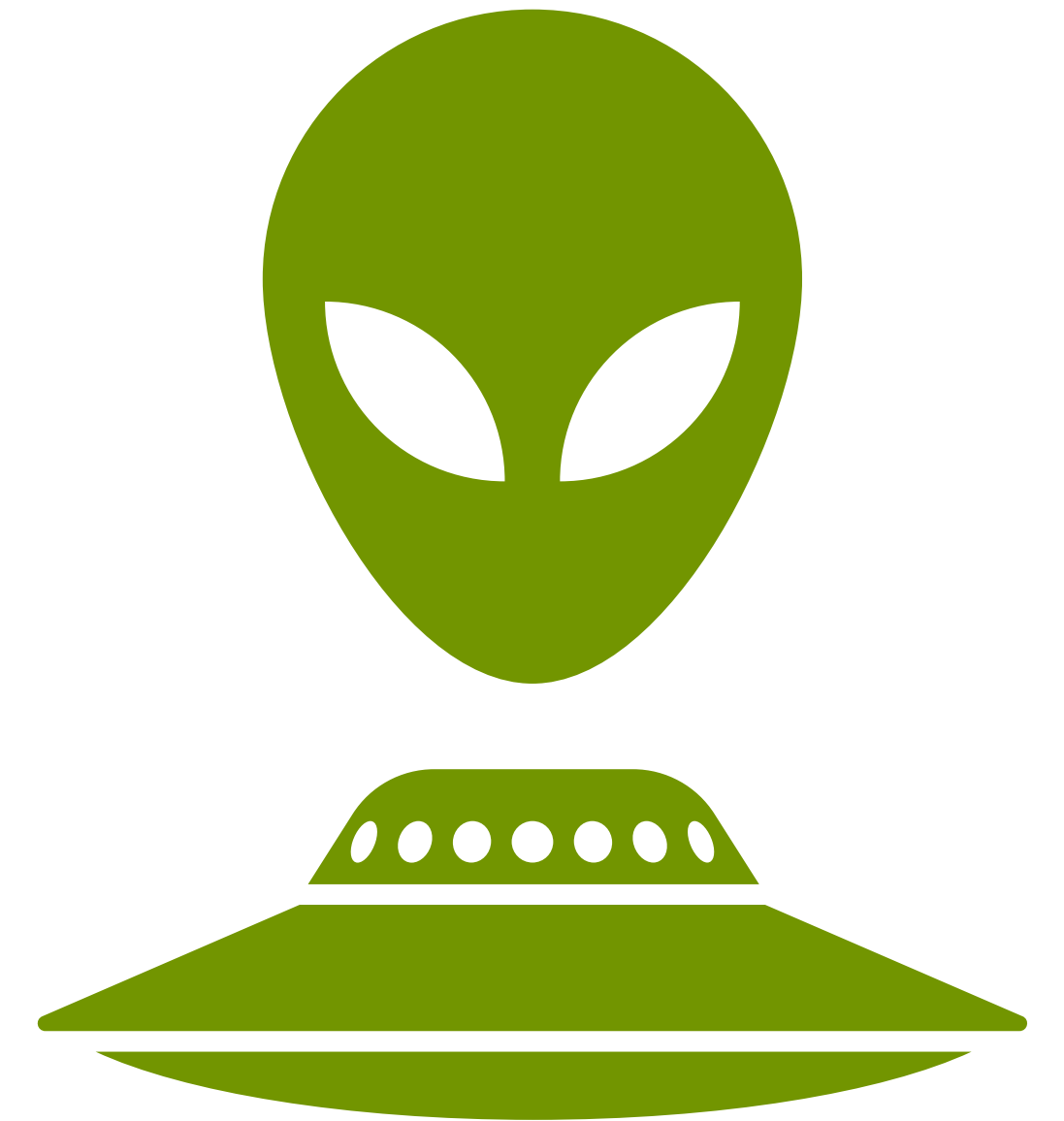

A cautionary tale about insufficient resolution

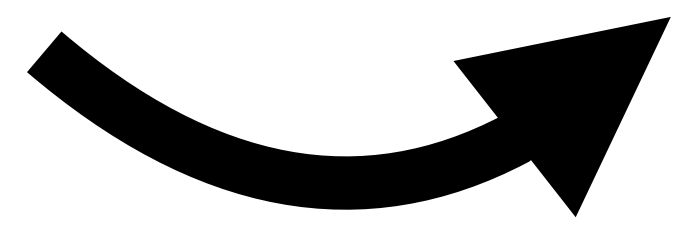
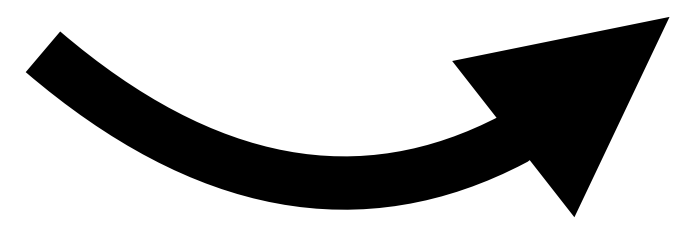
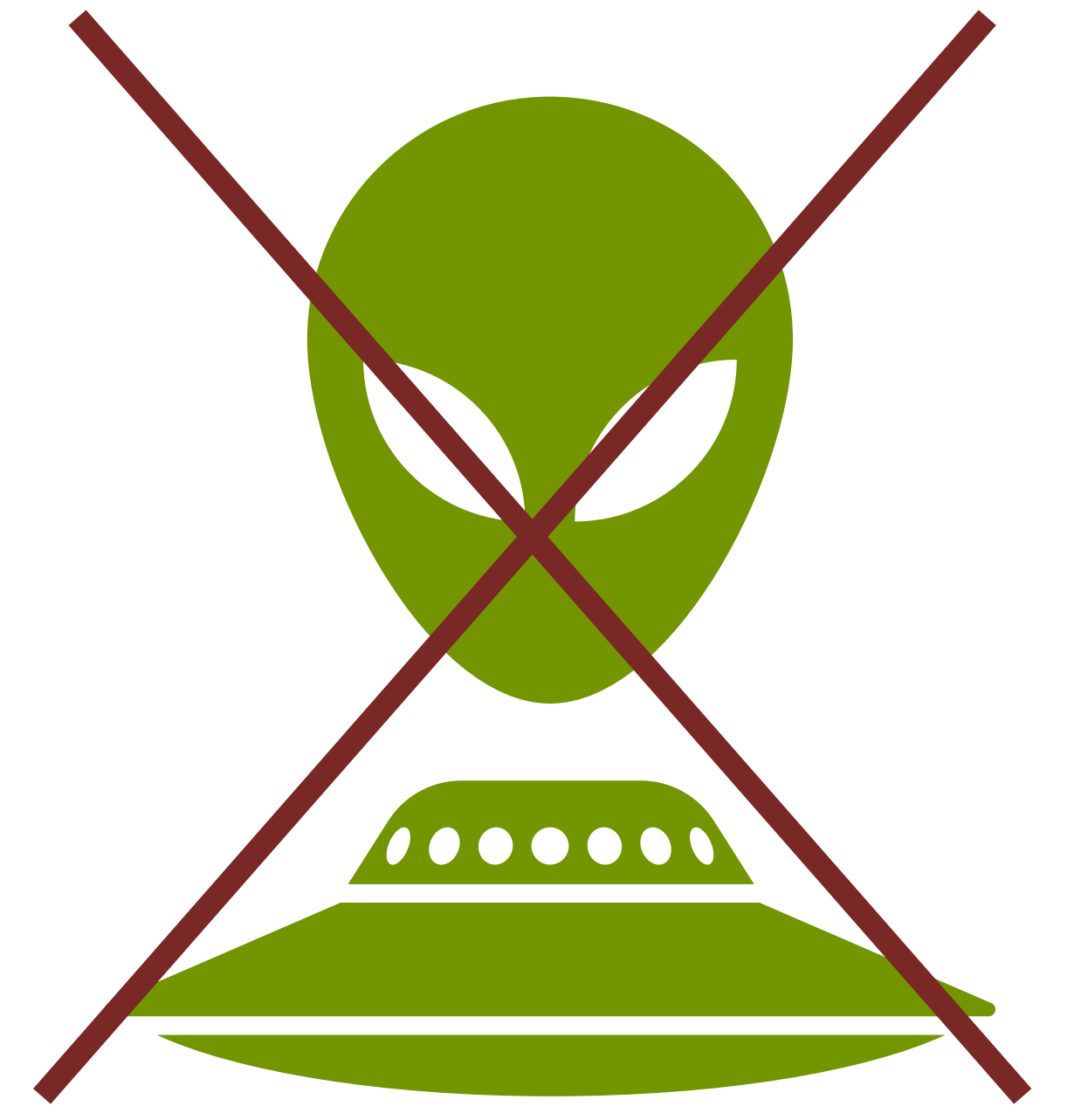
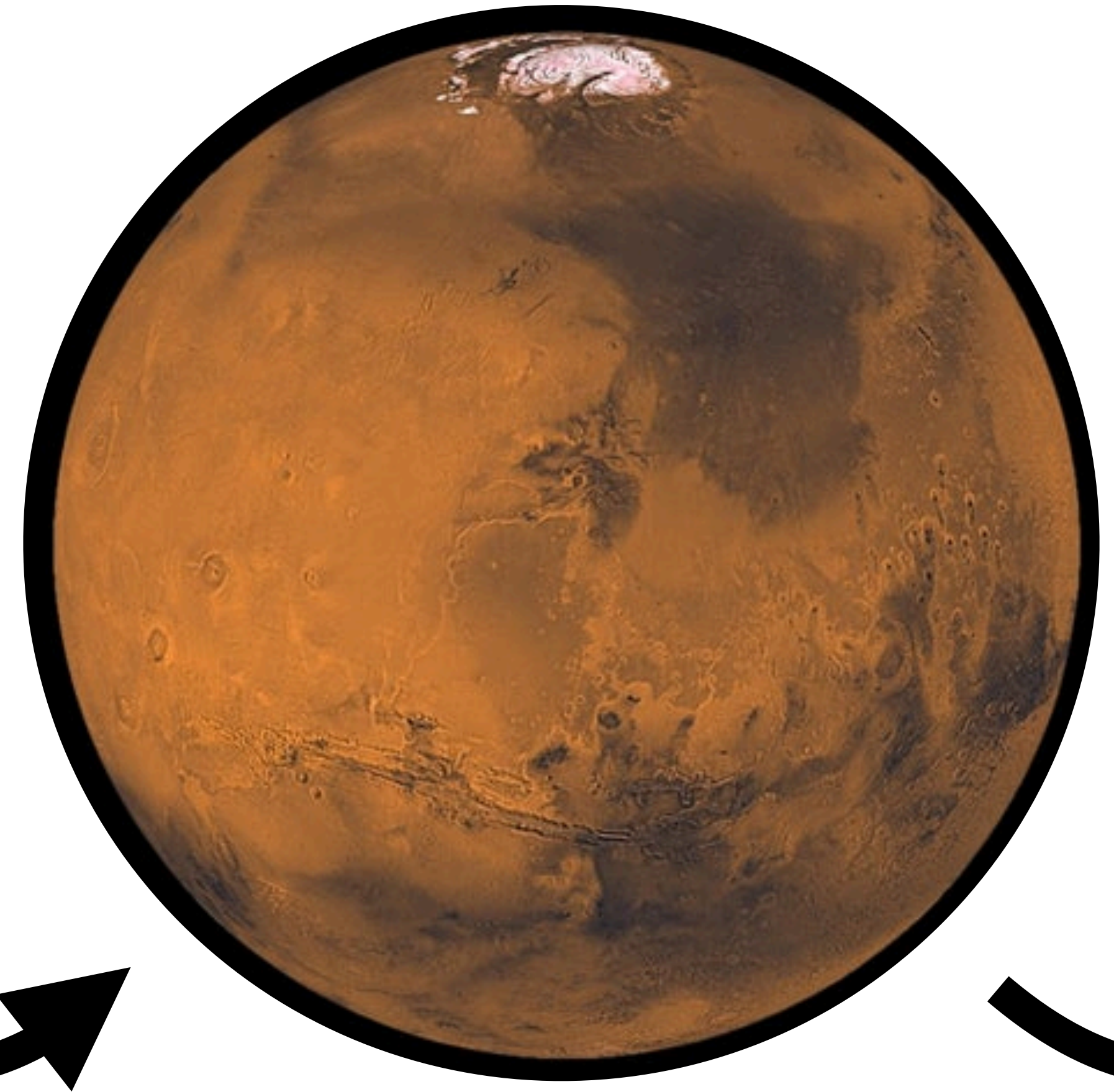

No canals on Mars!

Back to particles: looking at the Standard Model

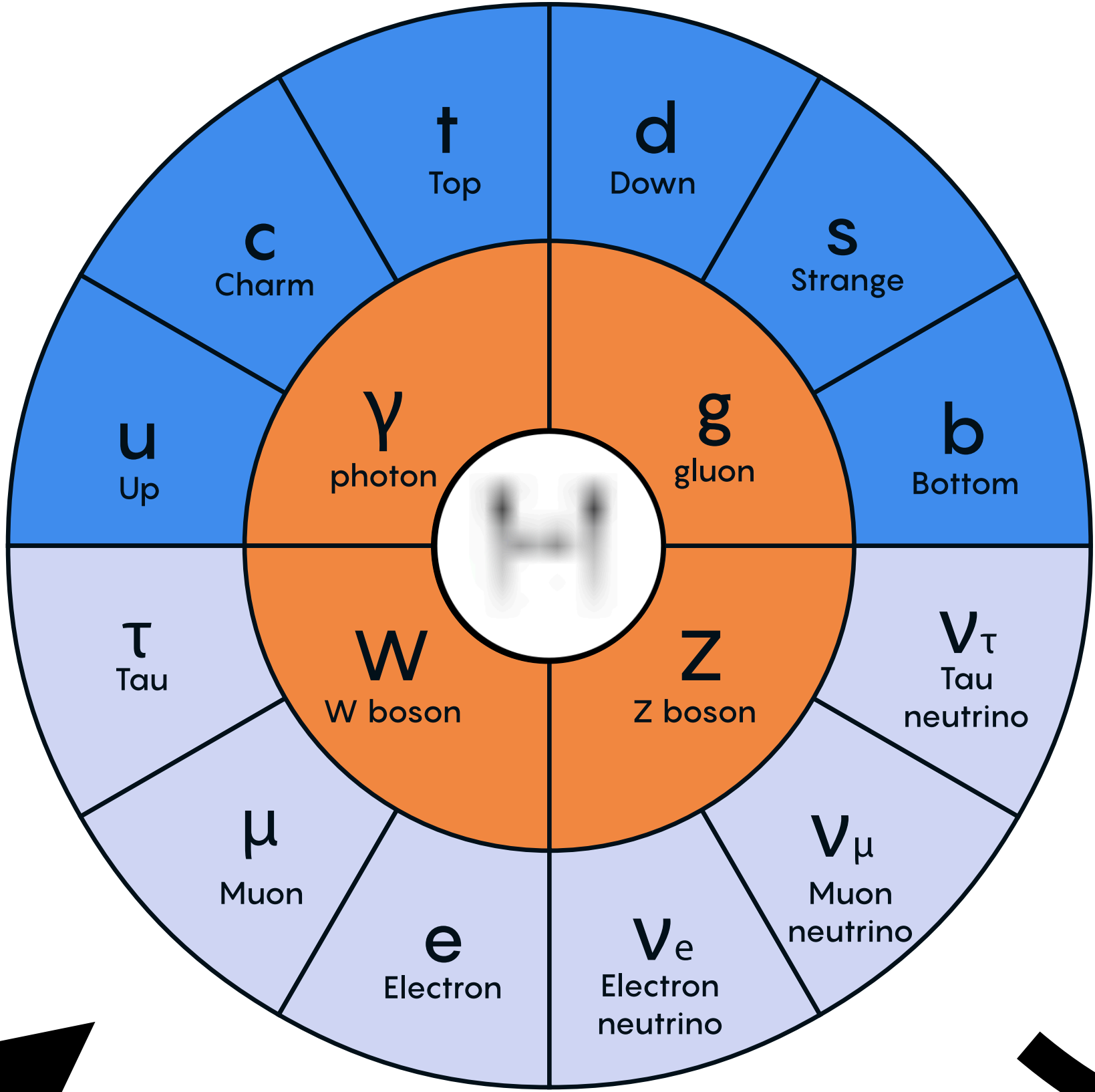

new physics

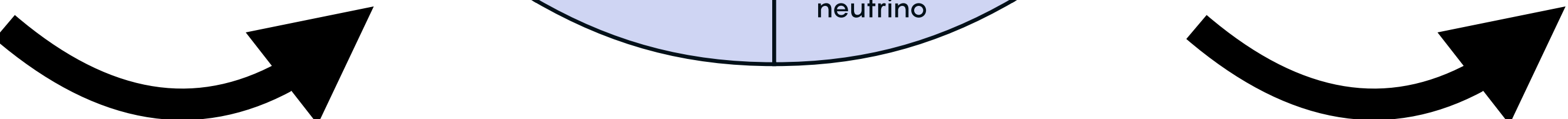
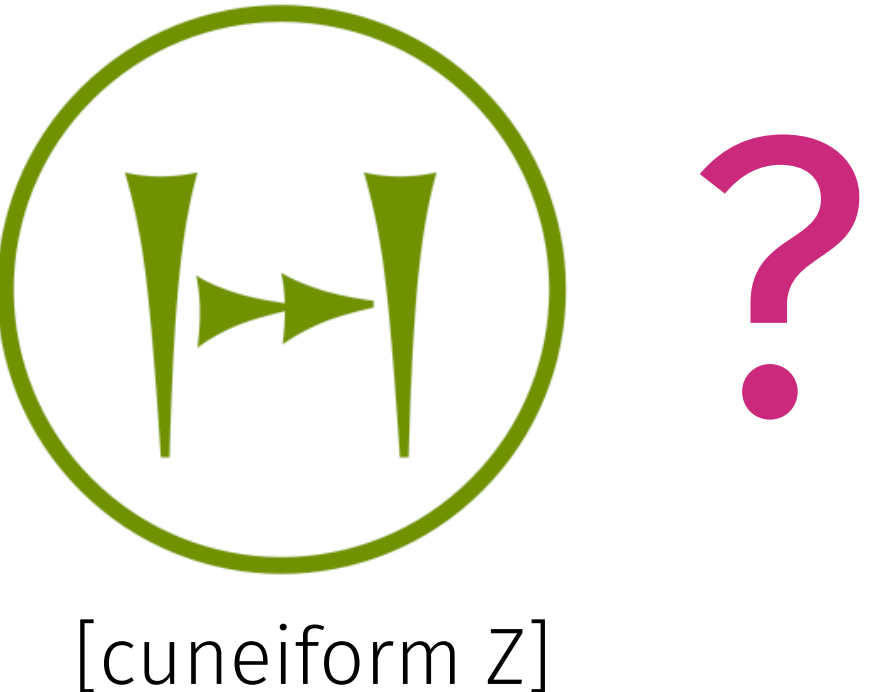

Our „picture“ of the Standard Model of Particle Physics



Our „telescope“: the ATLAS detector

- ▶ Layered LHC detector encapsulating interaction point: central tracker inside of a solenoid, calorimeters and an independent muon spectrometer with superconducting toroids

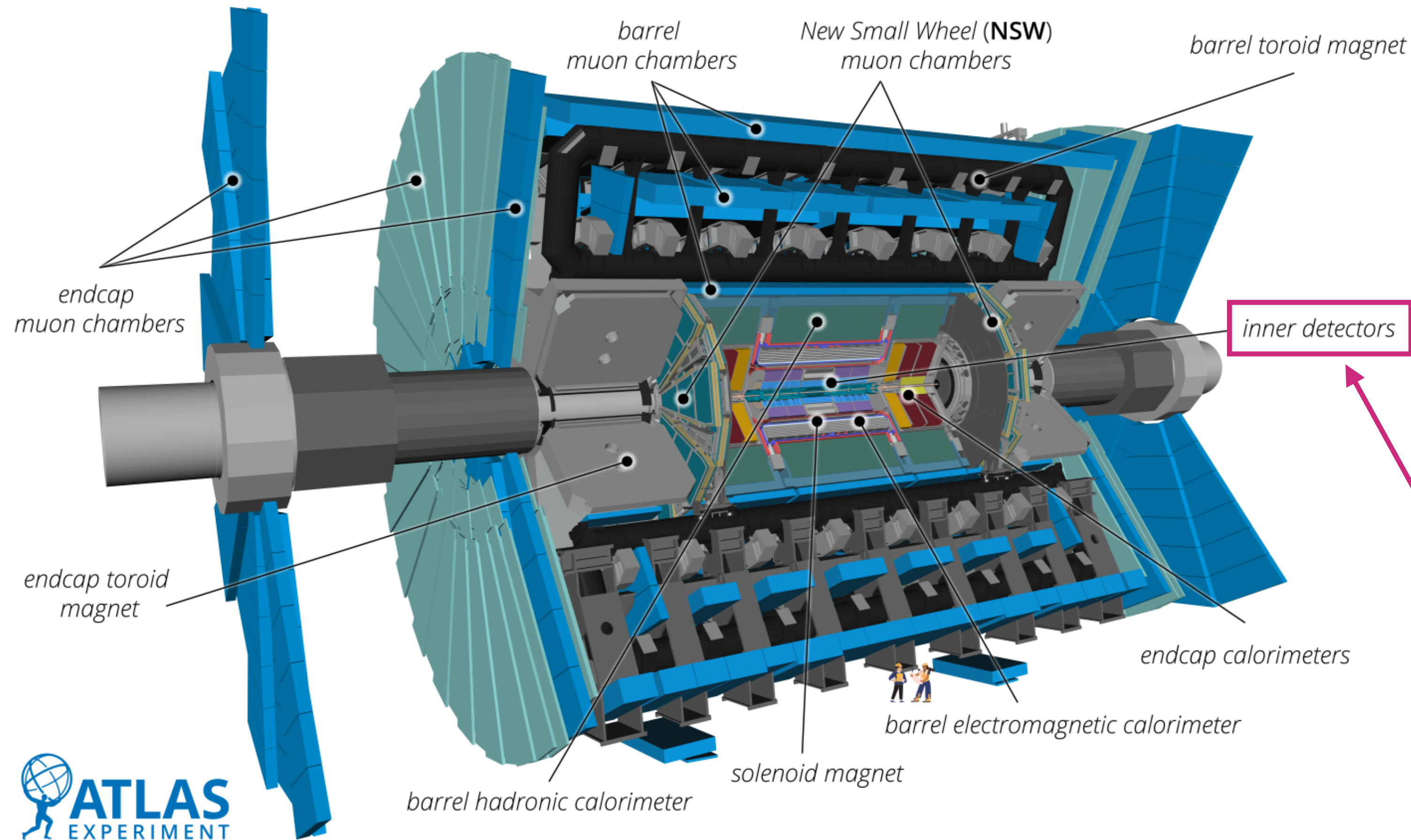

- ▶ Fast triggering on interesting signatures [**leptons, jets, ...**]
- ▶ Precise reconstruction of:
 - collision vertices
 - photons and **electrons**
 - **muons**
 - τ -leptons
 - jets
 - missing transverse momentum (MET)
- ▶ Identification of **heavy flavor jets and hadronic τ decays**

The Standard Model of Particle Physics ...

The Beauty

- Interactions among force particles, and between matter and force particles
- They arise from internal **symmetries** (requiring local gauge invariance)
- 3 free parameters

$$\mathcal{L}_{\text{SM}} = -\frac{1}{4}F_{\mu\nu}F^{\mu\nu} + i\bar{\psi}\not{D}\psi$$

The Beast

- The “Higgs sector”
- Introduced **ad-hoc**
- **15** free parameters
- **Descriptive**, but lacking a deeper understanding
- Couplings with vastly different values spanning orders of magnitude

$$+ |D_{\mu}\phi|^2 - \mu^2(\phi^{\dagger}\phi) - \lambda(\phi^{\dagger}\phi)^2 + y_{ij}\psi_i\phi\psi_j + \text{h.c.}$$



The Standard Model of Particle Physics ...

The Beauty

- Interactions among force particles, and between matter and force particles
- They arise from internal **symmetries** (requiring local gauge invariance)
- 3 free parameters

$$\mathcal{L}_{\text{SM}} = -\frac{1}{4}F_{\mu\nu}F^{\mu\nu} + i\bar{\psi}\not{D}\psi$$

The Beast

- The “Higgs sector”
- Introduced **ad-hoc**
- **15** free parameters
- **Descriptive**, but lacking a deeper understanding
- Couplings with vastly different values spanning orders of magnitude

$$+ |D_{\mu}\phi|^2 - \mu^2(\phi^{\dagger}\phi) - \lambda(\phi^{\dagger}\phi)^2 + y_{ij}\psi_i\phi\psi_j + \text{h.c.}$$



... and the famous Higgs potential $V(H)$

arbitrary \uparrow > 0 \uparrow highest term even, else any polynom. would do

$$V(\phi) = -\mu^2(\phi^\dagger\phi) + \lambda(\phi^\dagger\phi)^2 \longrightarrow V(H) = \frac{1}{2}m_H^2 H^2 + \lambda \text{ vev } H^3 + \frac{1}{4}\lambda H^4$$

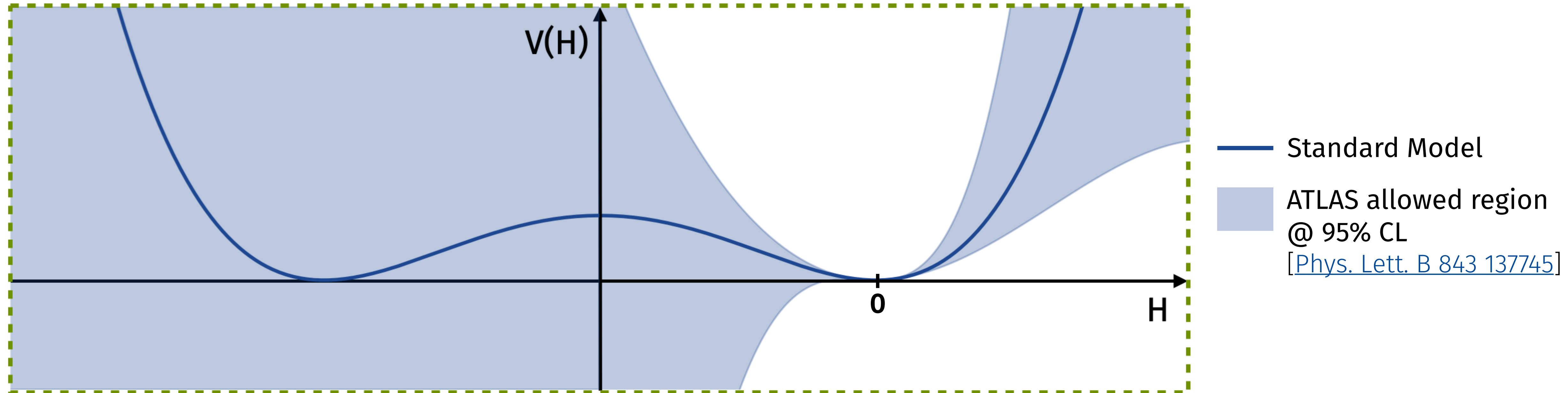

Why **is the Higgs potential Mexican-hat shaped?**

The Higgs potential and the big open questions

From the stability of the vacuum ...

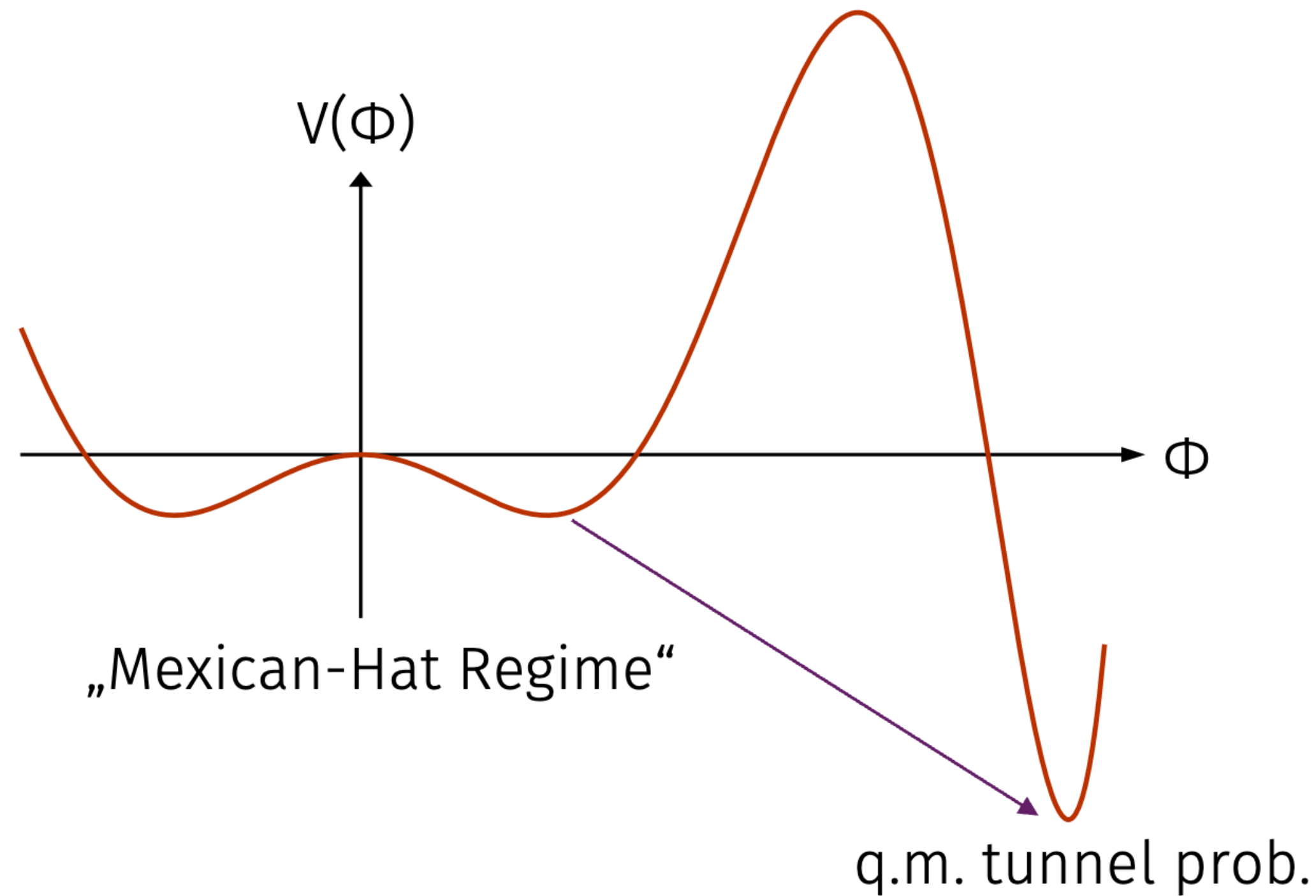

Stable?

Meta-stable?

... to explaining the matter-antimatter asymmetry

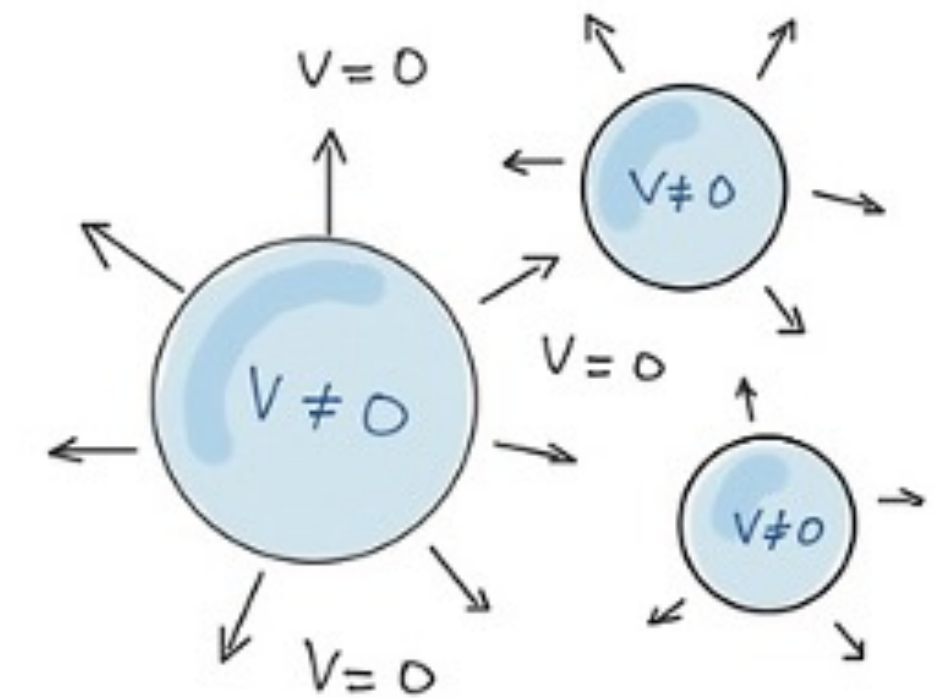
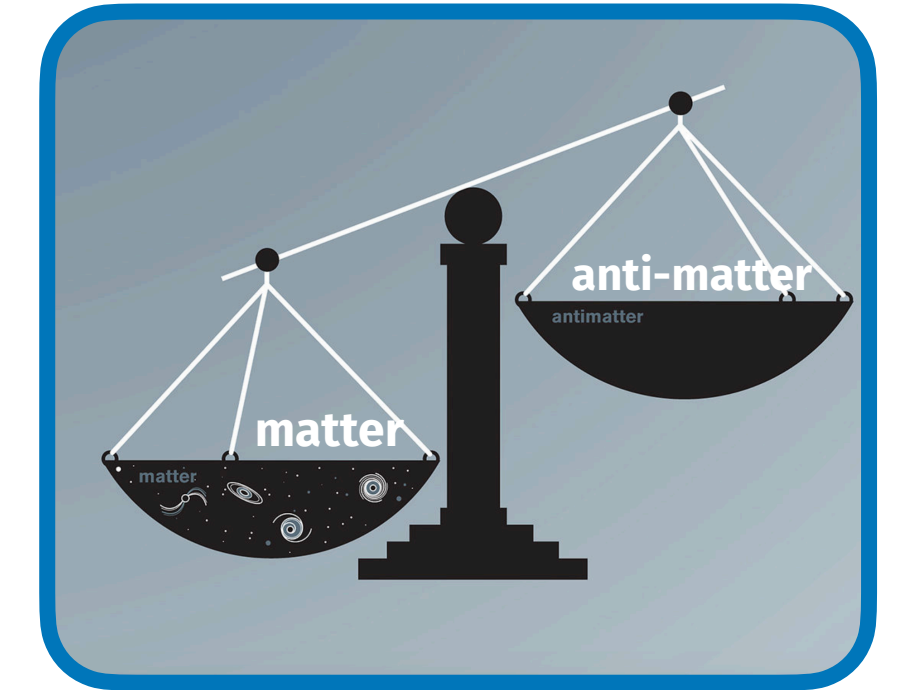
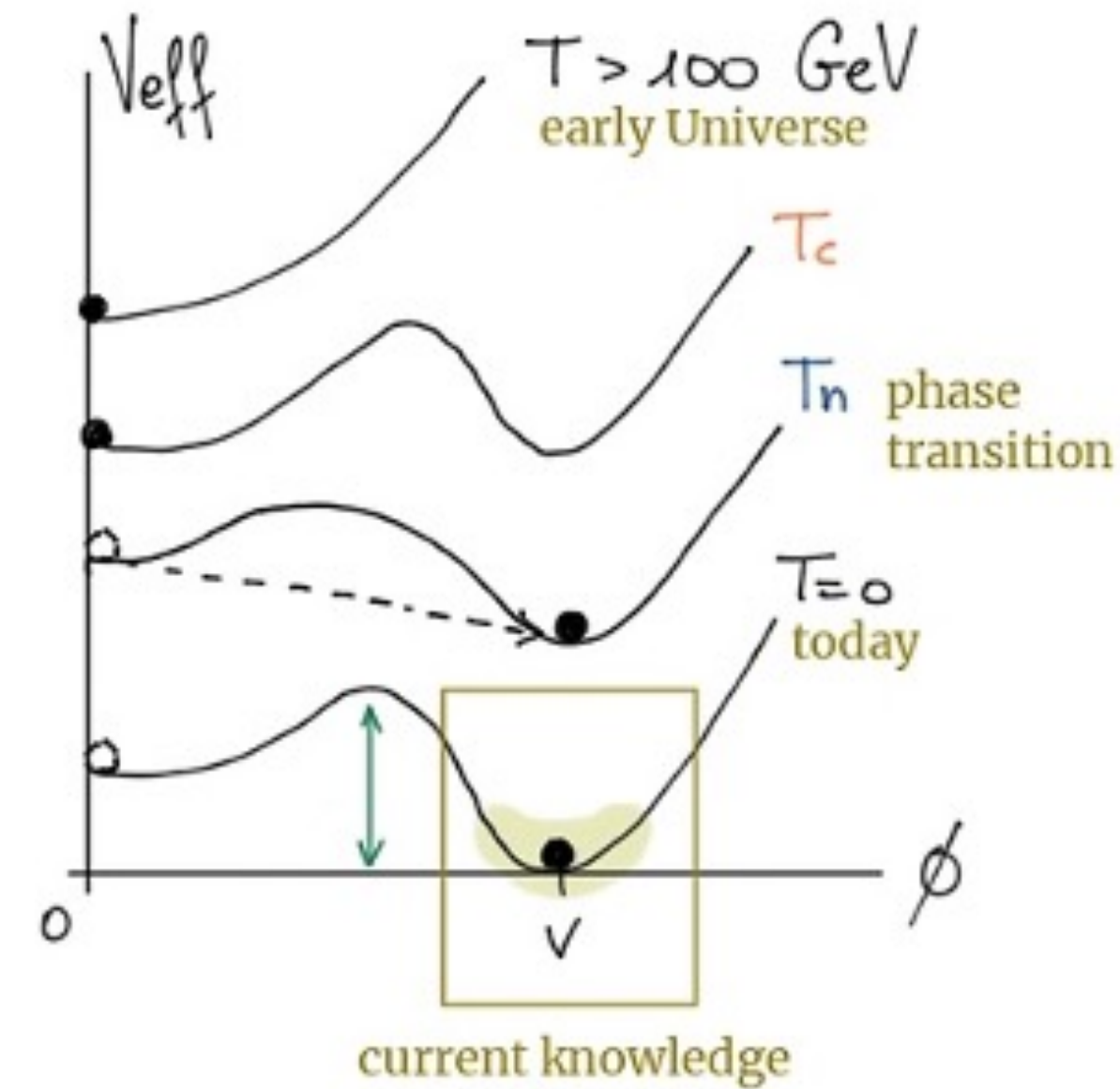

Non-SM Higgs potential needed for electroweak baryogenesis

How to measure the Higgs potential?

$$V(H) = \frac{1}{2} m_H^2 H^2 + \lambda \text{vev} H^3 + \frac{1}{4} \lambda H^4$$

(vev known with sub-% precision from muon lifetime)

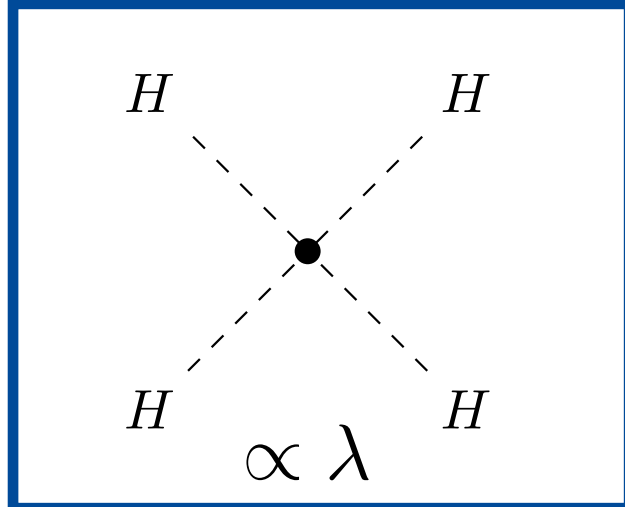
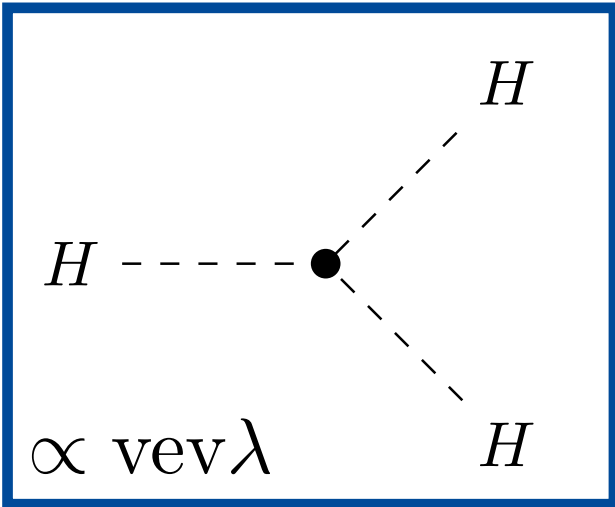
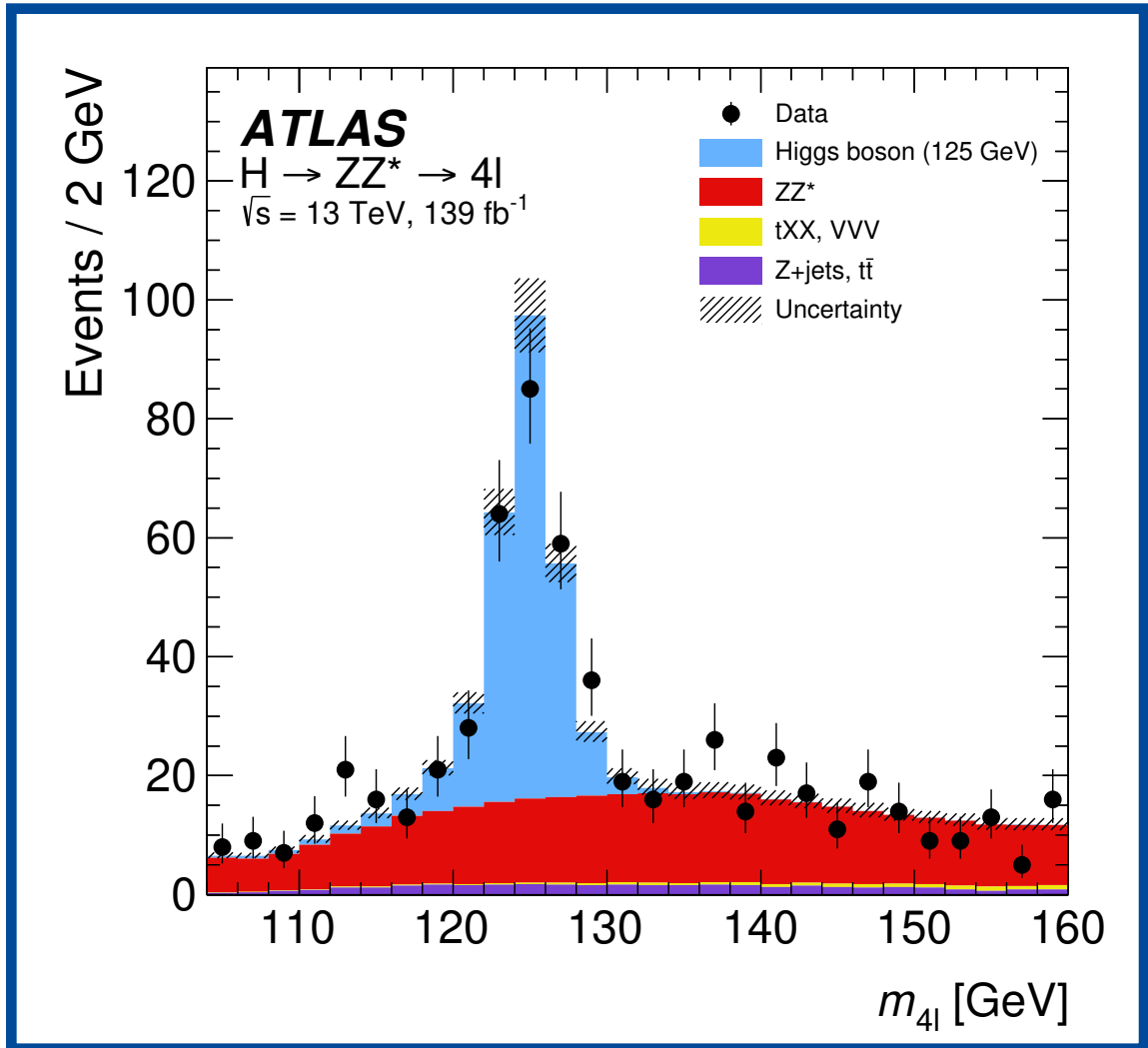

In the SM:

$$\lambda = \frac{m_H^2}{2\text{vev}^2} \approx \frac{125^2}{2 \cdot 246^2} \approx \frac{1}{8}$$

Any deviation would be a clear sign of new physics!

Measure $pp \rightarrow HH$ to determine λ :

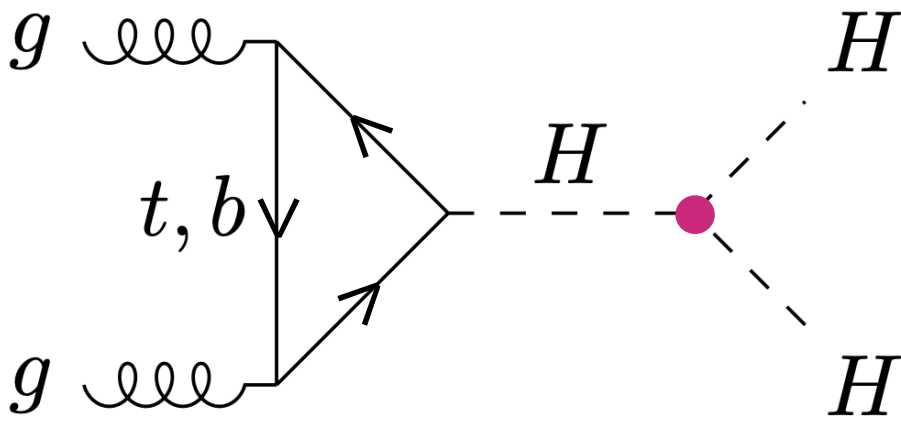

ATLAS $H \rightarrow ZZ^* \rightarrow 4\ell + H \rightarrow \gamma\gamma$ Run 1 + Run 2

$m_H = 125.11 \pm 0.09 \text{ (stat.)} \pm 0.06 \text{ (syst.)}$
 [0.09% relative uncertainty]

[Phys. Rev. Lett. 131 (2023) 251802]



This seminar: 2 snapshots of my work ...

... all aimed to increase resolution

1. Measuring the shape of the Higgs potential

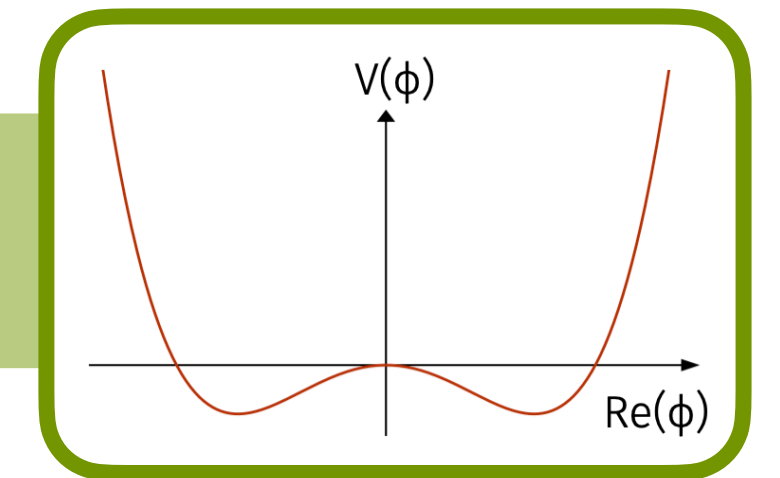

2. Building the new ATLAS pixel detector

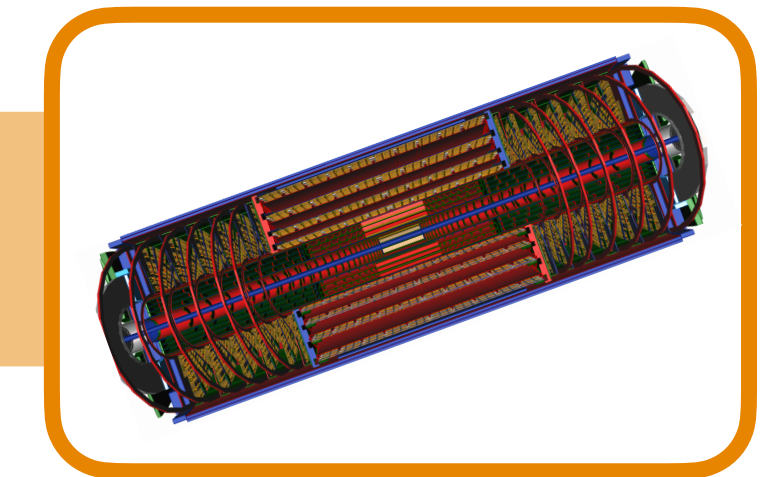

This seminar: 2 snapshots of my work ...

... all aimed to increase resolution

1. Measuring the shape of the Higgs potential

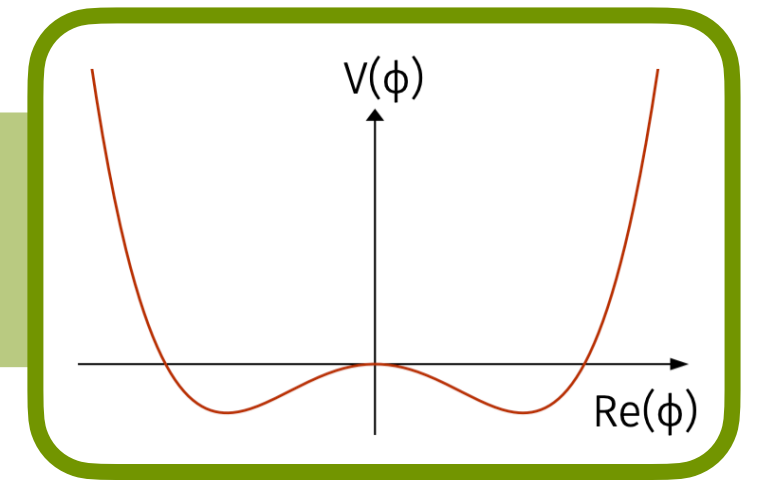

2. Building the new ATLAS pixel detector

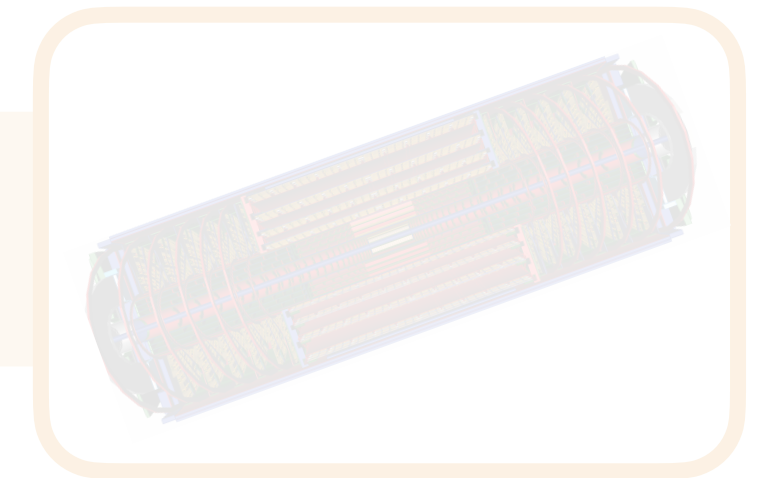

How to look for HH production?

- ▶ Same production modes as for single Higgs production: ggF, VBF, VH, ttH, ...
- ▶ Small cross-section → **only ~ 4000 HH pairs** produced during LHC Run 2

ggF: $\sigma = 31^{+2.7}_{-7}$ fb @ NNLO FT approx. [13 TeV]

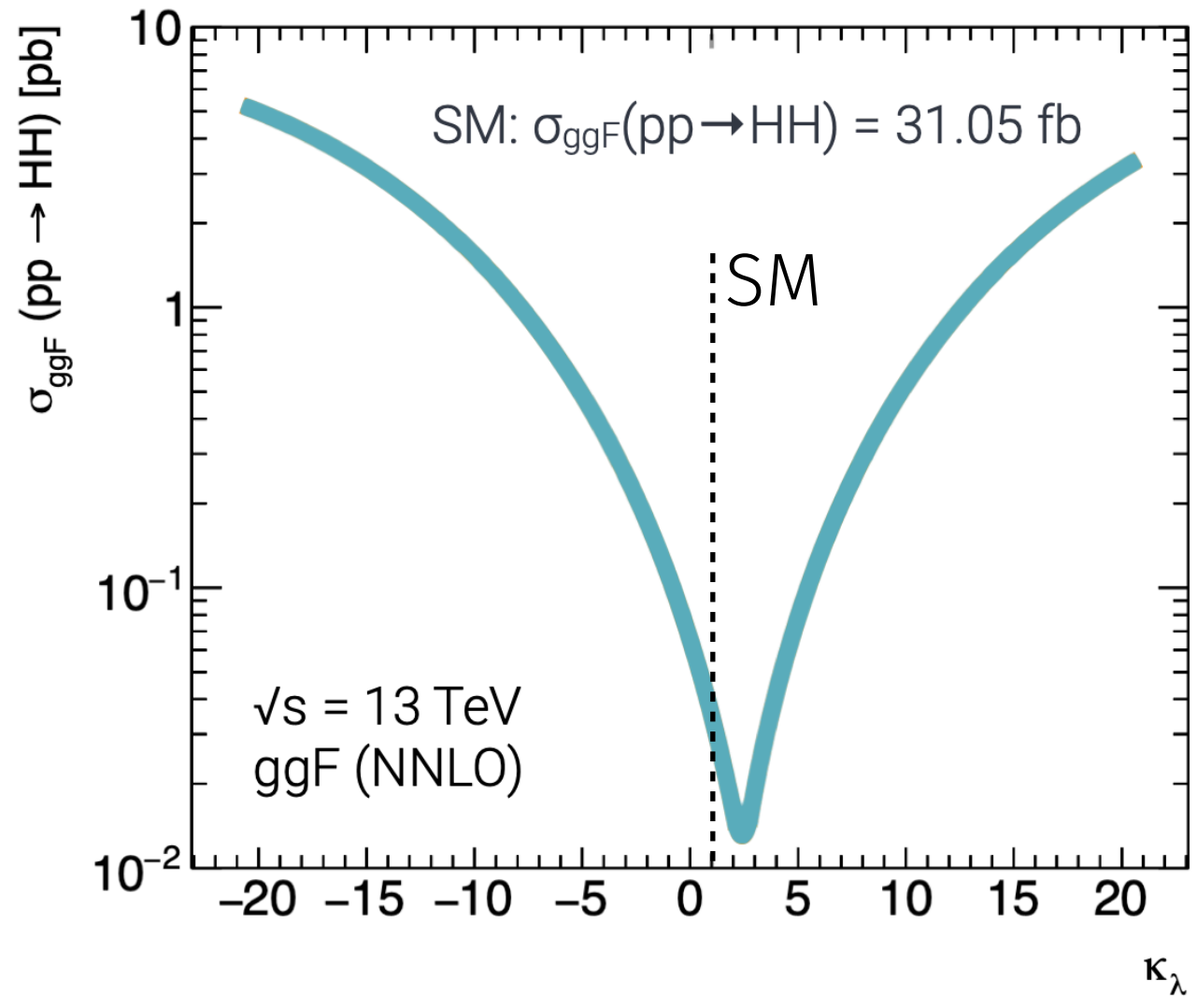
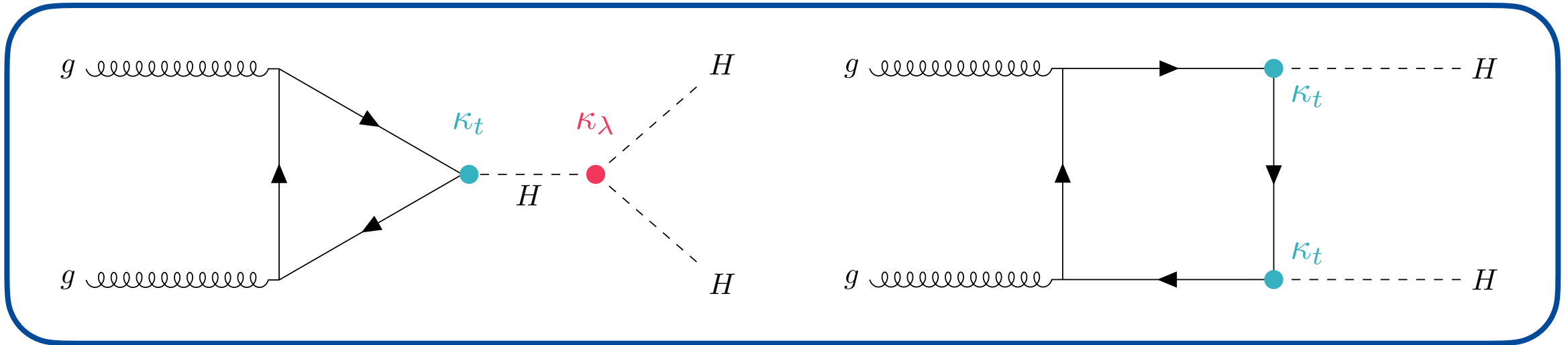
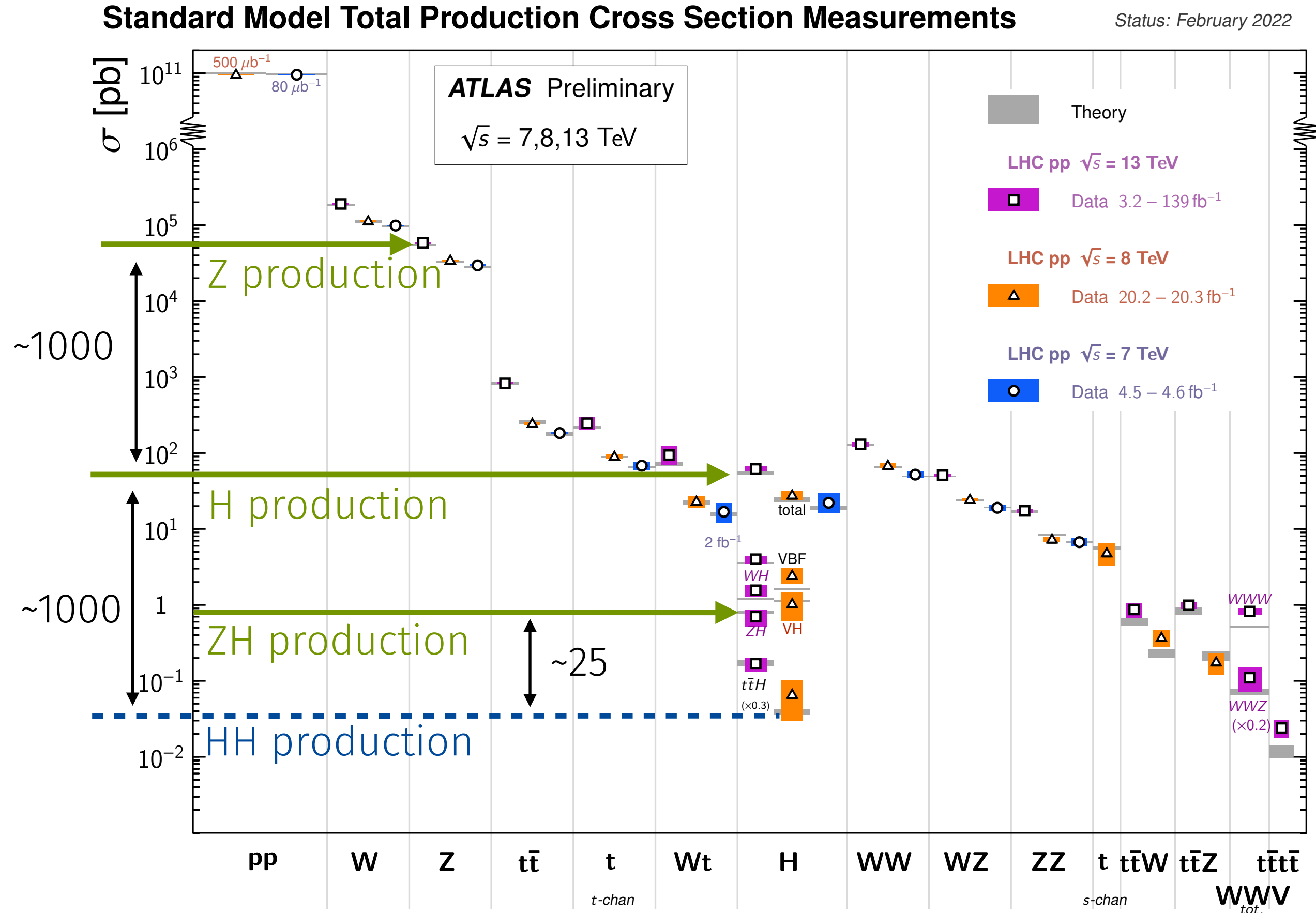

$$\kappa_\lambda = \frac{\text{measured self-coupling}}{\text{SM prediction}}$$

Larger values of $|\kappa_\lambda|$ enhance the HH production cross-section significantly



Which decay channel to pick?

- ▶ Same production modes as for single Higgs production: ggF, VBF, VH, ttH, ...
- ▶ Small cross-section → **only ~ 4000 HH pairs** produced during LHC Run 2
- ▶ Balance needed between high signal yield and high background rejection

BRs	bb	WW	$\tau\tau$	ZZ	$\gamma\gamma$
bb	34%				
WW	25%	4.6%			
$\tau\tau$	7.3%	2.7%	0.39%		
ZZ	3.1%	1.1%	0.33%	0.069%	
$\gamma\gamma$	0.26%	0.10%	0.028%	0.012%	0.0005%

The “golden” channels:

$H(\rightarrow bb)H(\rightarrow bb)$:
largest BR, but huge QCD multi-jet background

$H(\rightarrow bb)H(\rightarrow \tau\tau)$:
moderate BR, multi-jet rejection due to presence of τ

$H(\rightarrow bb)H(\rightarrow \gamma\gamma)$:
small BR, but very clean signature + benefits from $m_{\gamma\gamma}$ resolution

Most sensitive channels all require at least one $H \rightarrow bb$

The search for $pp \rightarrow HH \rightarrow bb\tau\tau$

My role:
 Main analyser $\tau_{had}\tau_{had}$, 2022-2024
 Analysis coordination since 2023

- Two analysis channels, depending on the τ decays: $\tau_{had}\tau_{had}$ and $\tau_{lep}\tau_{had}$
 [$\tau_{lep}\tau_{lep}$ is included in the $pp \rightarrow HH \rightarrow bbl\ell$ analysis]

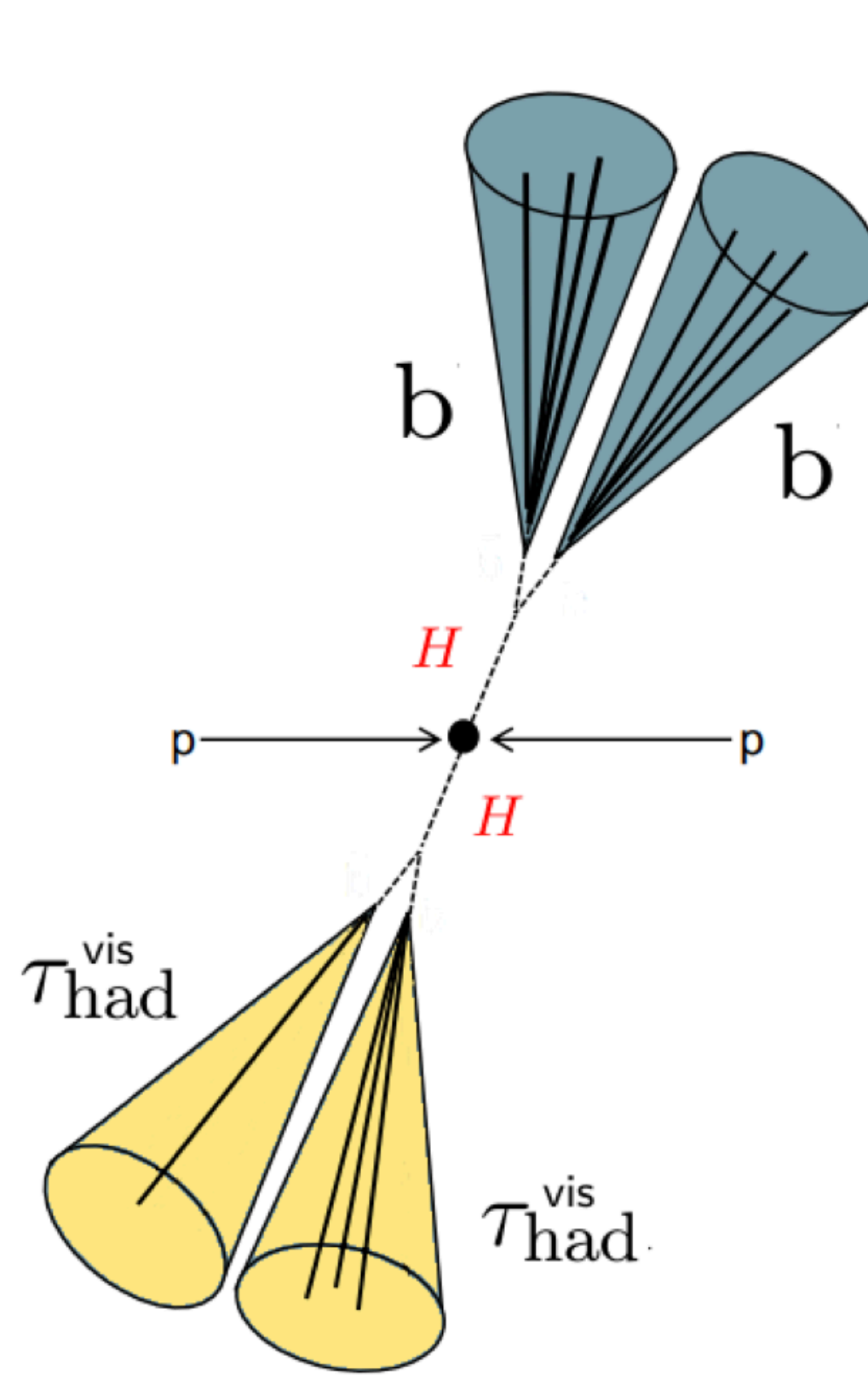

$\tau_{had}\tau_{had}$

$\tau_{had}\tau_{had}$

single and di- τ_{had} triggers

exactly two τ_{had}

0 electrons/muons

exactly two b-tagged jets

👎 difficult trigger strategy
 👍 lower backgrounds
 👍 better di- τ resolution

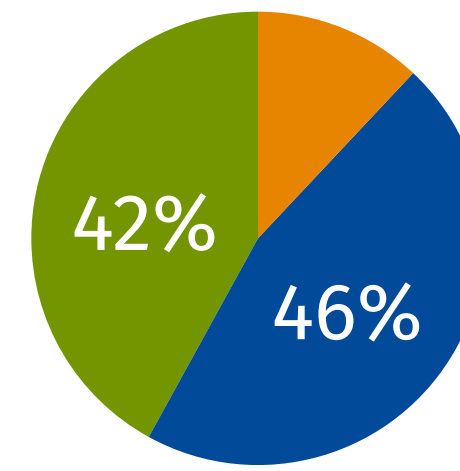

$\tau_{lep}\tau_{had}$

single e/μ triggers

exactly one τ_{had}

1 electron or 1 muon

👍 better to trigger on
 👎 larger backgrounds

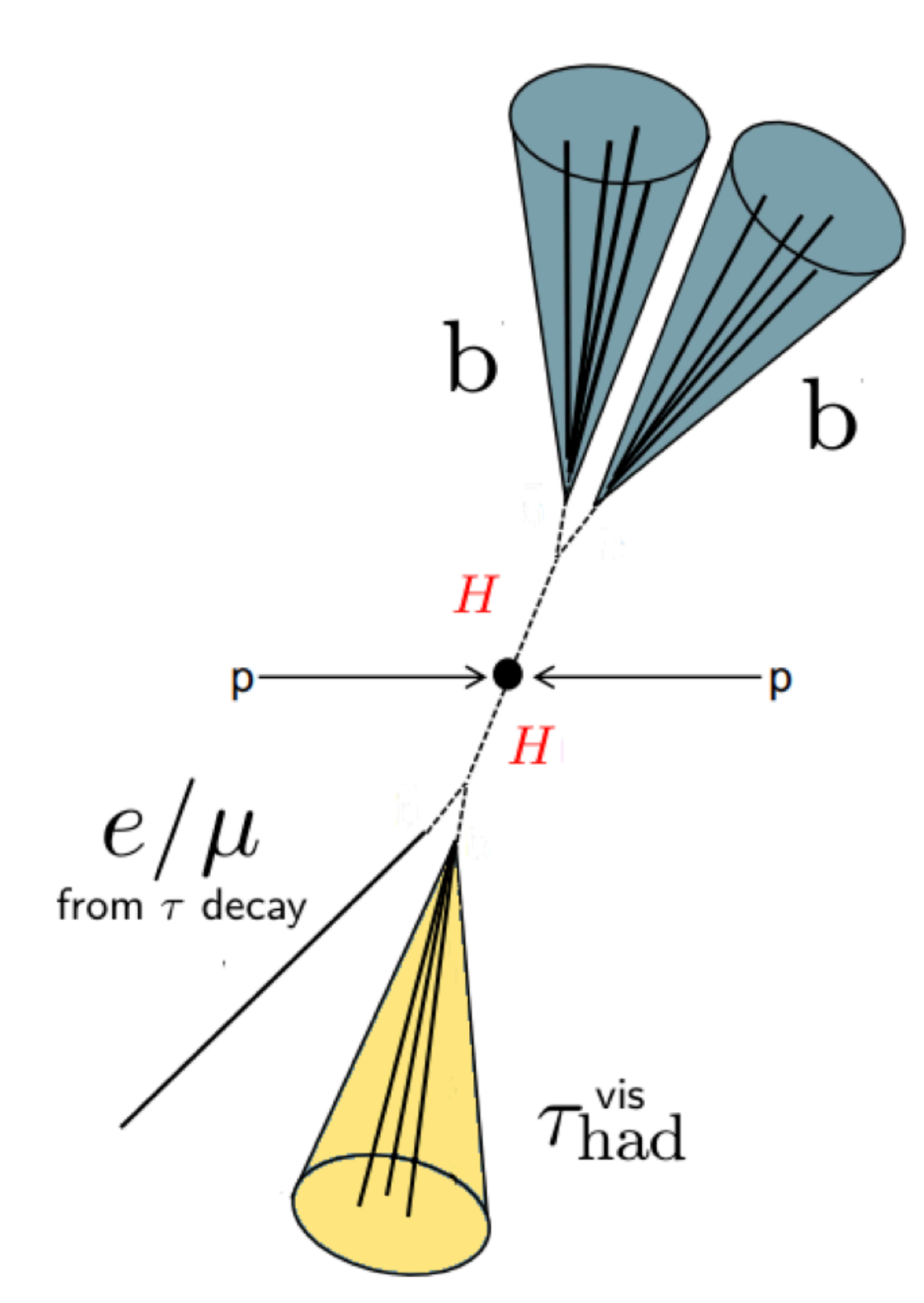

$\tau_{lep}\tau_{had}$

[[Phys. Rev. D 110 \(2024\) 032012](#)]

with F. Haslbeck (then Oxford, now CERN)

Brian Moser

Does the Higgs boson wear a Mexican-hat?

14/05/2026



$HH \rightarrow bb\tau_{\text{had}}\tau_{\text{had}}$
candidate event

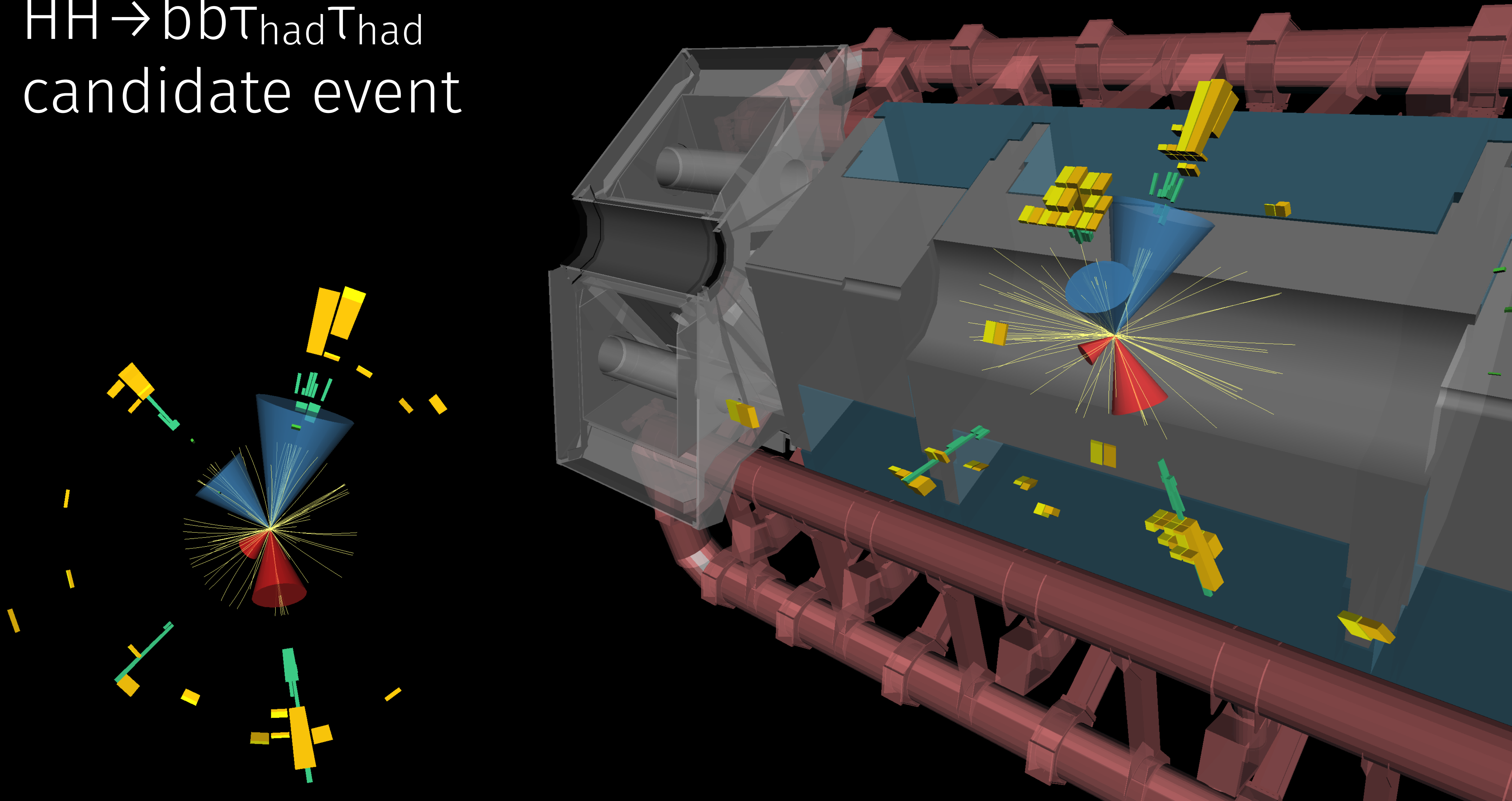

Main backgrounds and how to control them

Main backgrounds:

- ttbar
- Z+ heavy flavour jets

dedicated control region

- single top
- single Higgs
- diboson

from simulation

- ttbar with jet $\rightarrow \tau_{\text{had}}$ fakes
- QCD multijet with jet $\rightarrow \tau_{\text{had}}$ fakes

data-driven

Example regions:

had-had high- m_{HH} SR

$\sim 450 \times \text{HH}$

$\sim 160 \times \text{HH}$

$\sim 40 \times \text{HH}$

$\sim 10 \times \text{HH}$

$\sim 5 \times \text{HH}$

$\sim 250 \times \text{HH}$

$\sim 150 \times \text{HH}$

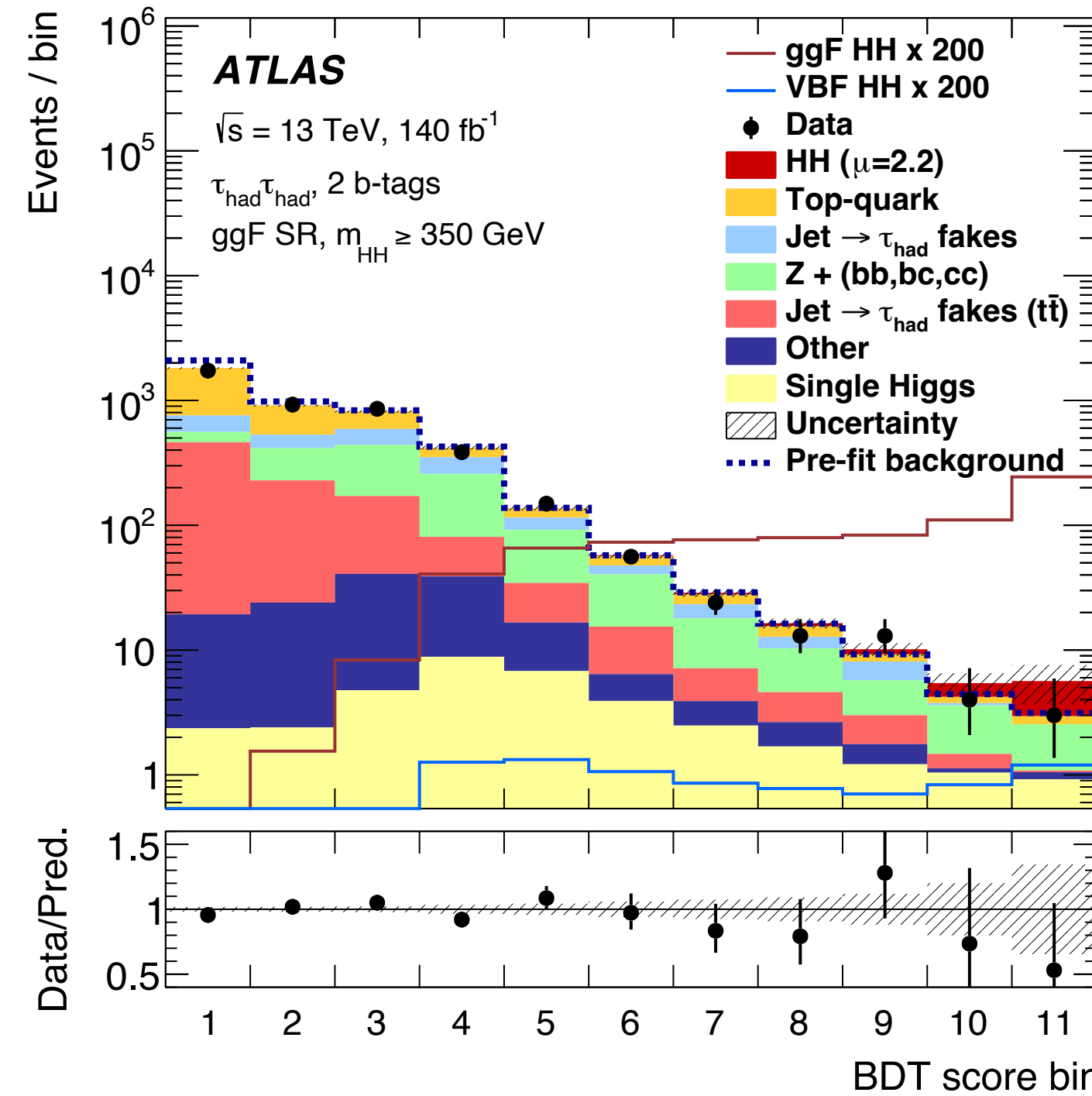

Z+hf region

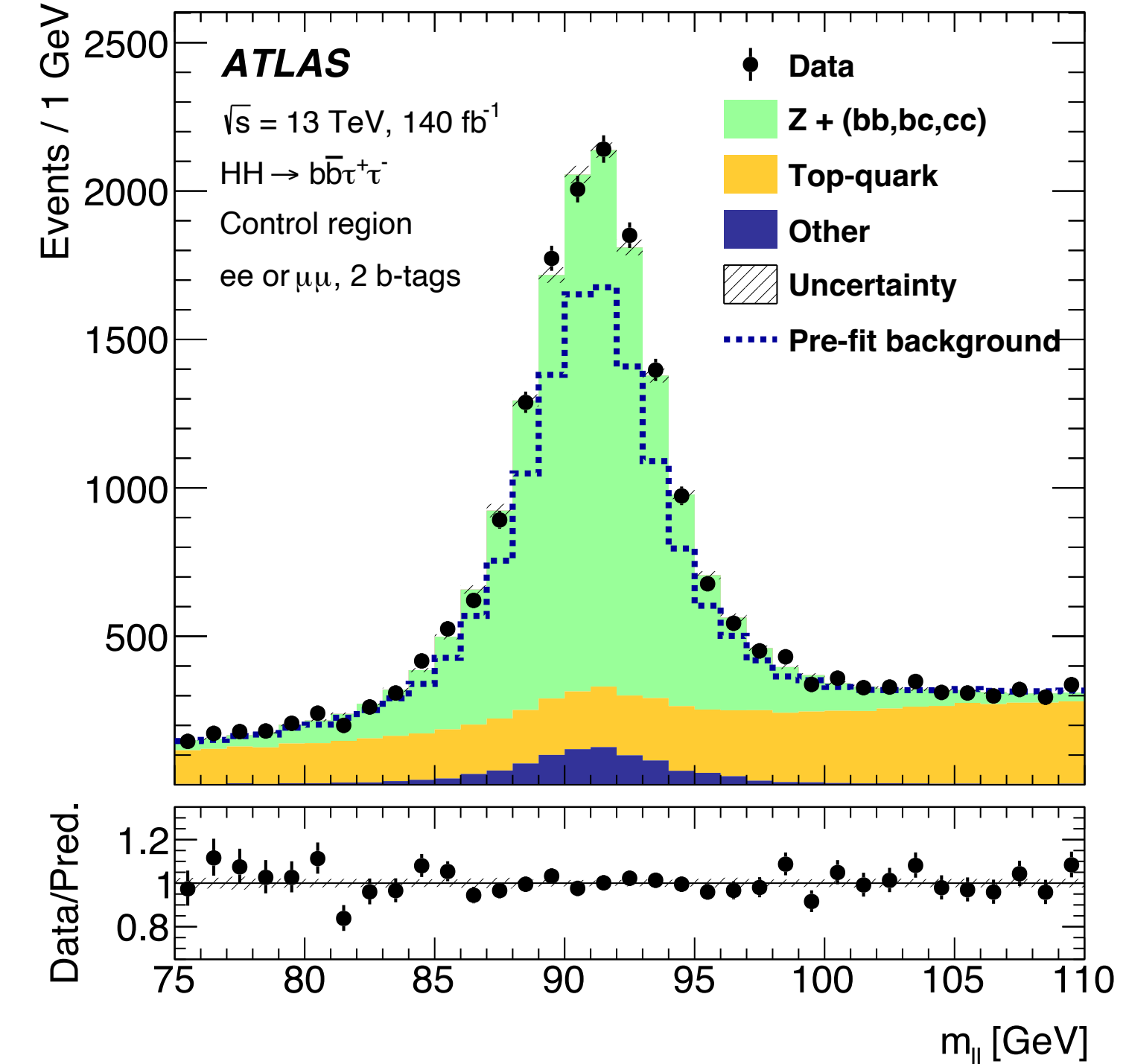

Name of the game:

Signal vs. background discrimination
 \rightarrow multivariate analysis methods



The results at one glance

$pp \rightarrow HH \rightarrow bb\tau\tau$ signal strength $< 5.9 \times \text{SM}$ @ 95% CL [3.3 expected]

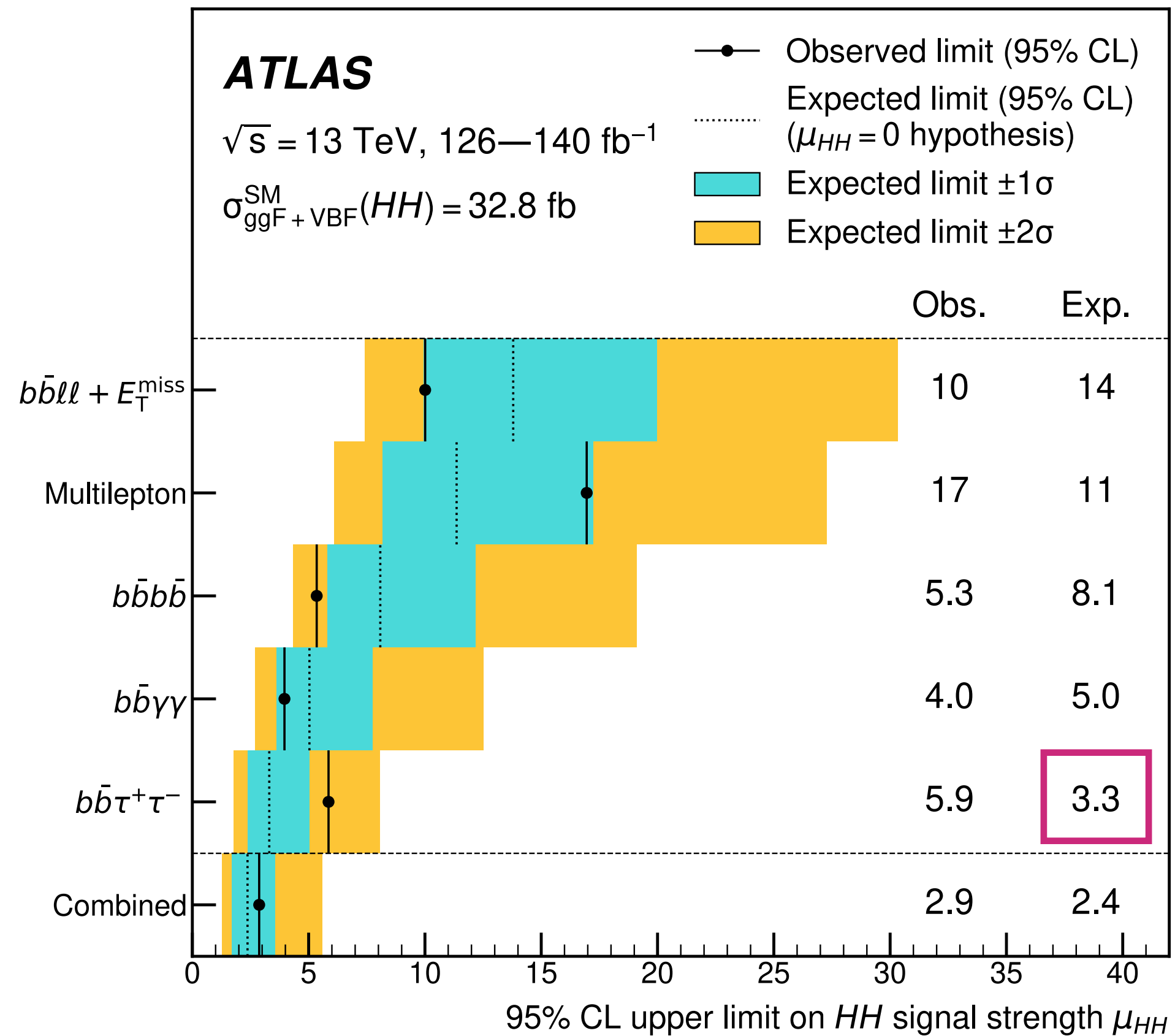

$HH \rightarrow bb\tau\tau$ leading expected limit on HH signal strength

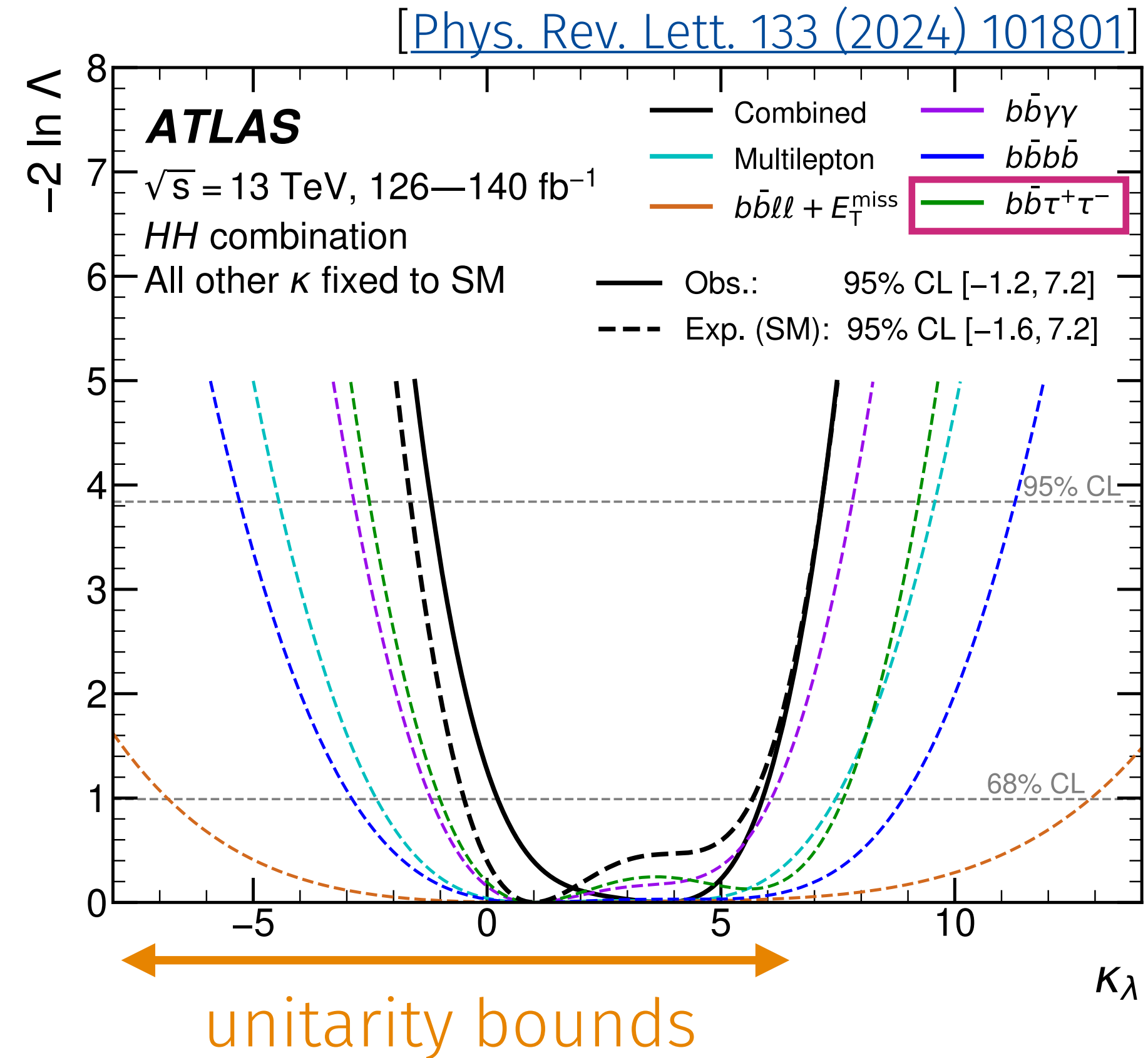

$HH \rightarrow bb\tau\tau$ best limits on lower κ_λ side

How did we get there?

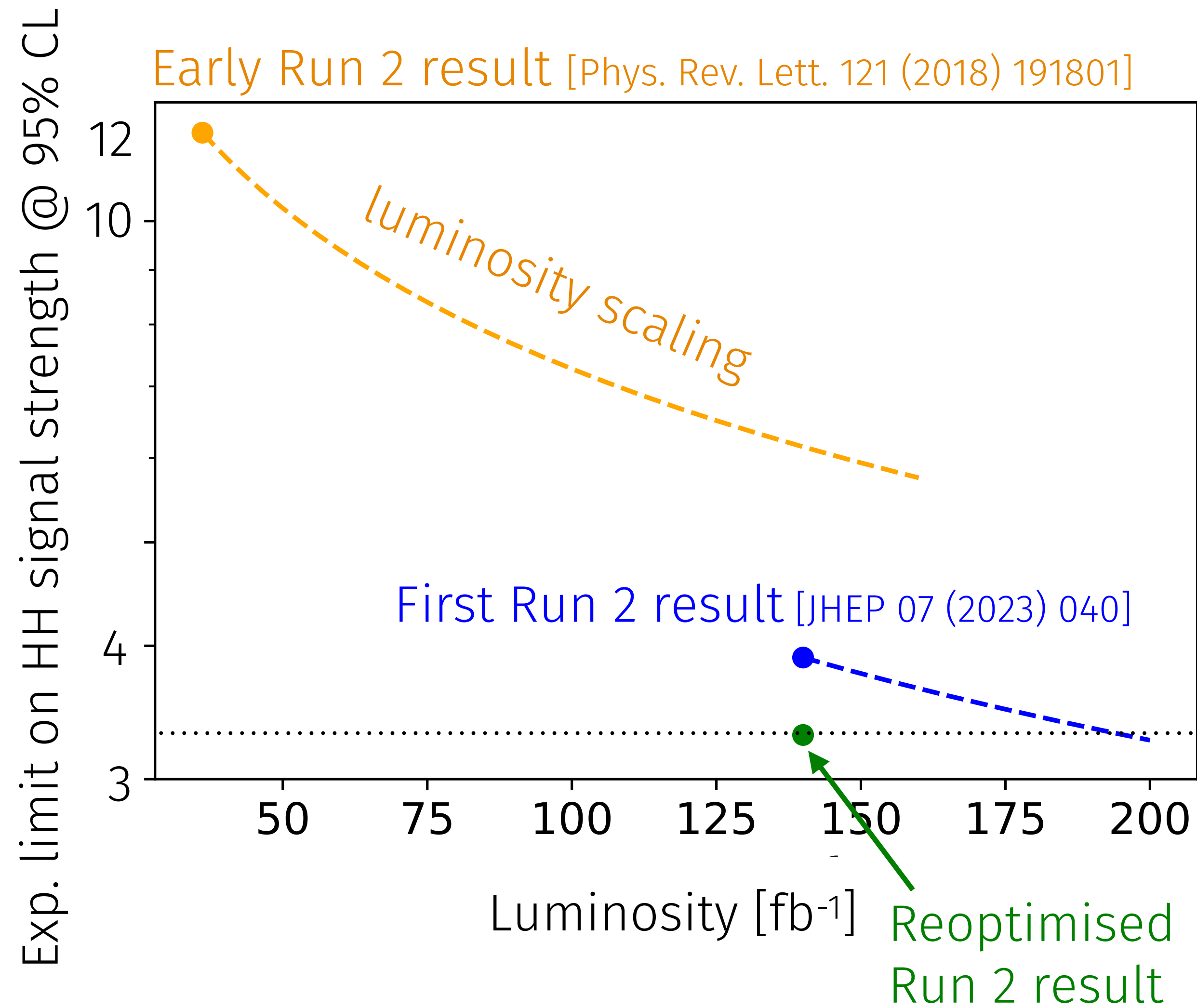

First Run 2 result was a compromise between a resonant search for $X \rightarrow \text{HH}$ and the non-resonant (SM) search

Re-analysis of Run 2 with focus on the non-resonant part

- more granular event categorization
- improved bkg simulation
- improved MVA

15% improvement → equivalent of adding 30% more data (half a year of data taking)

We are constantly beating the simple luminosity-based scaling → Creativity paired with hard work is certainly worth it

Where do we go from here?

- ▶ Run 3 of the LHC ongoing since 2022 (until mid-2026): will triple the available pp collision data set
- ▶ Comes hand-in-hand with analysis improvements [unfortunately, nothing public yet]

New **triggers** to improve the overall signal efficiency

40% higher efficiency at low m_{HH}

20% higher efficiency at high m_{HH}

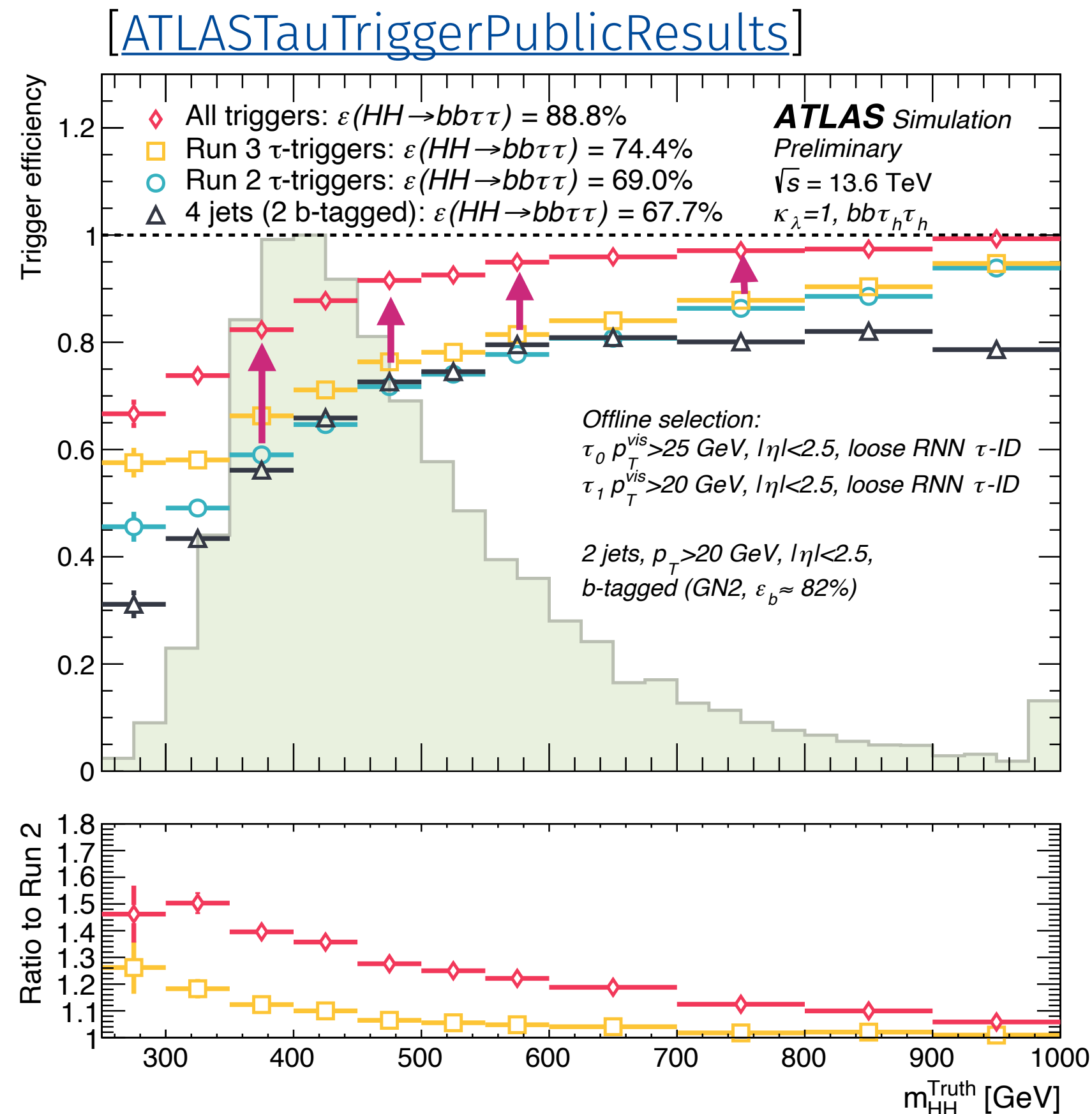

[G. Rupnik [master thesis](#)]

ALMA MATER STUDIORUM · UNIVERSITY OF BOLOGNA

School of Science
 Department of Physics and Astronomy
 Master Degree in Physics

**A Transformer and Novel Triggers
 for the Search for Higgs Boson Pair
 Production in the $b\bar{b}\tau^+\tau^-$ Final State
 with the ATLAS Detector**

Supervisor:
 Prof. Maximiliano Sioli

Submitted by:
 Giovanni Rupnik Boero

Co-supervisors:
 Dr. Brian Moser
 Prof. Valerio Dao

CERN-THESIS-2024-328
 / 2024

Terminal



Where do we go from here?

- ▶ Run 3 of the LHC ongoing since 2022 (until mid-2026): **will triple the available pp collision data set**
- ▶ Comes hand-in-hand with analysis improvements [**unfortunately, nothing public yet**]

Transformer-based networks are revolutionizing **b-tagging**

What is the rate of c-jets that will be mistakenly identified as b-jets?

Significant improvement in background rejection at the same signal efficiency

Seen in actual data (= calibrated)!

My role:
calibration convener, 2023-2025

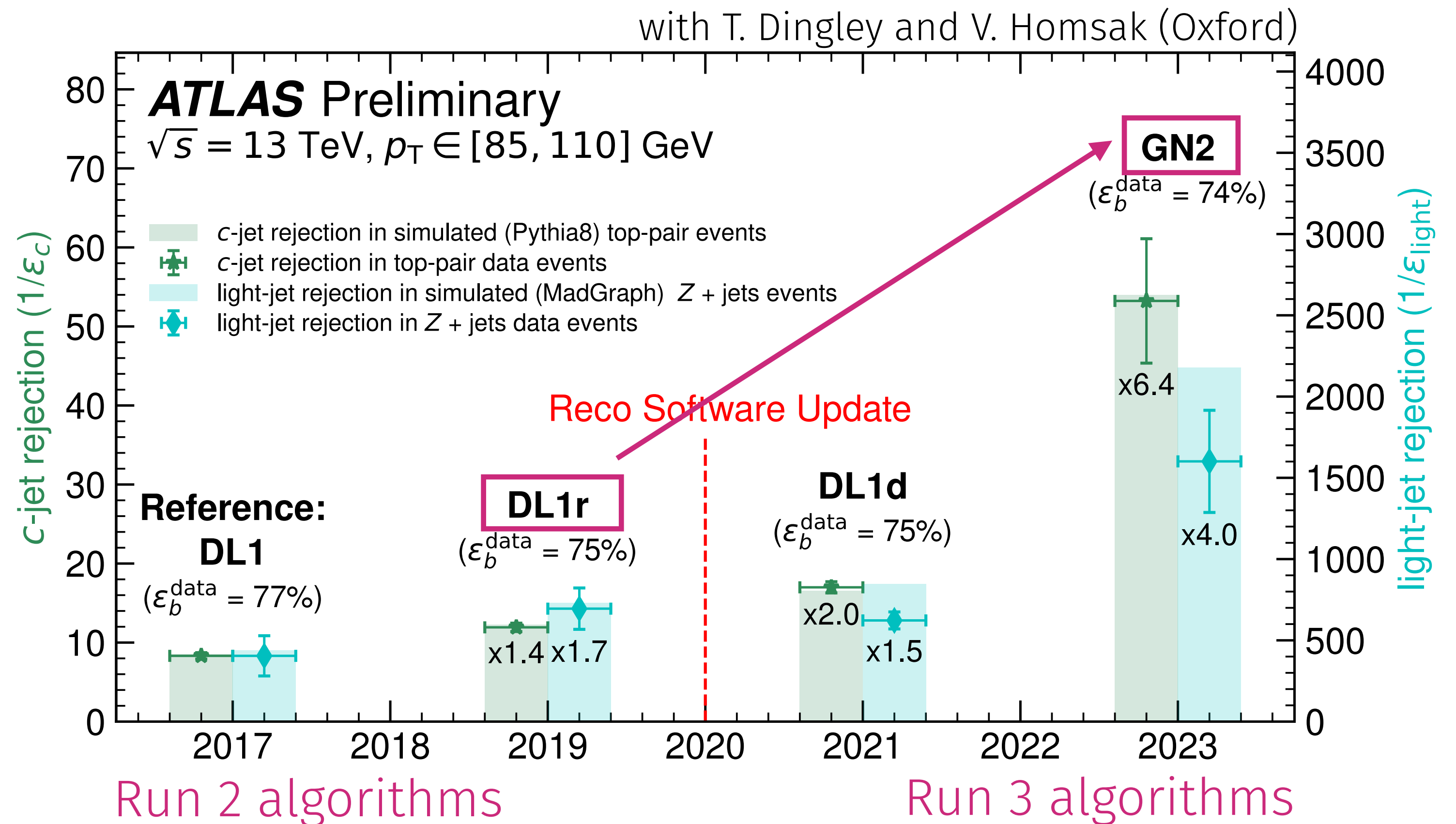

Ultimate HH precision with the HL-LHC dataset

Current searches for HH production are all **limited by the size of the pp collision dataset**
→ large improvements expected from the high luminosity upgrade of the LHC (HL-LHC)

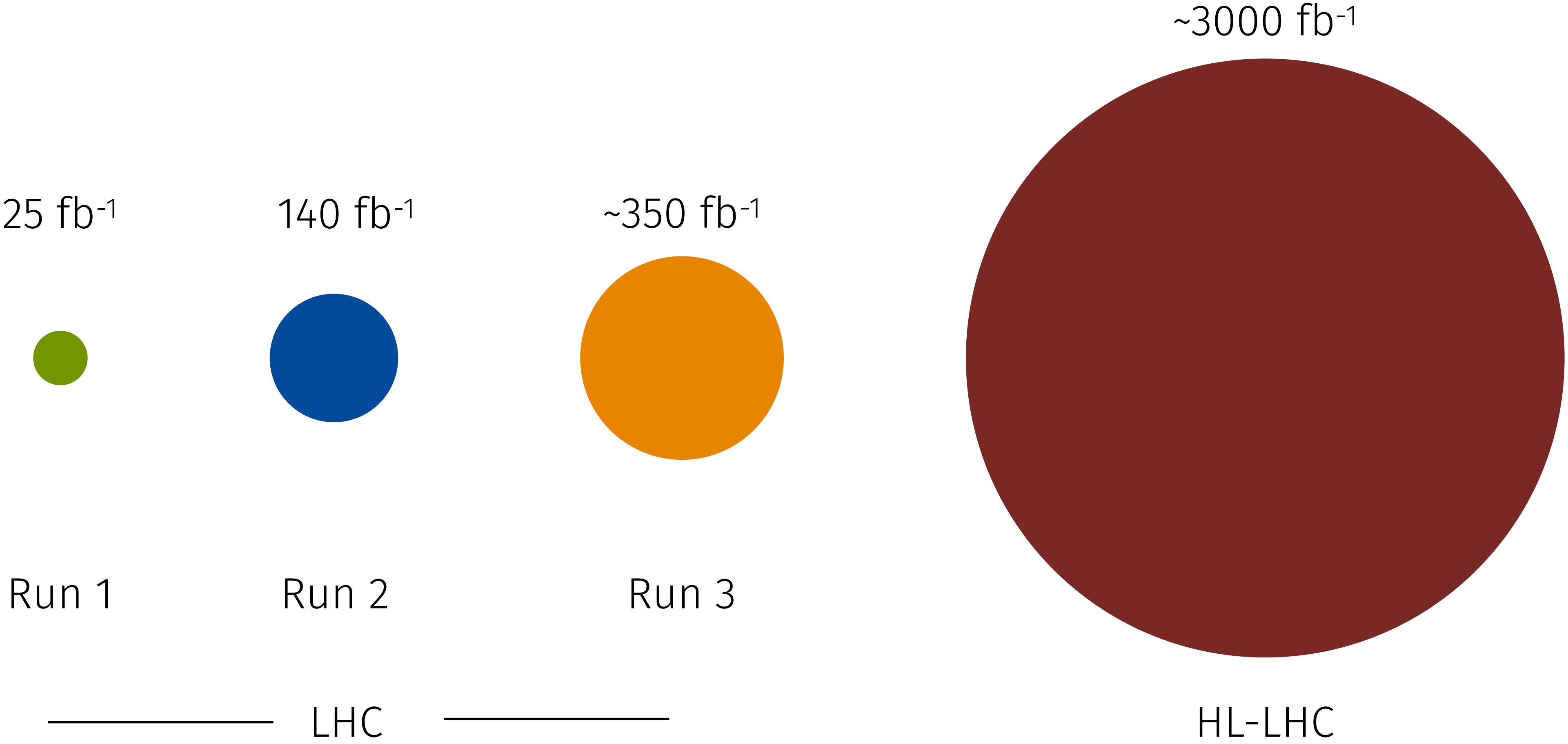

The ATLAS Inner Tracker Upgrade (ITk)

- ▶ LHC will increase the average number of collisions per bunch crossing from ~ 60 (Run 3) to ~ 200 (HL-LHC) to be able to deliver the 3000 fb^{-1}
- ▶ The current inner detector can not withstand these environments
- Novel **all-silicon tracker** to replace the full ATLAS inner detector
 - Radiation harder, more granular, increased coverage up to $|\eta| \leq 4$
 - Lower material budget to minimize multiple scattering
 - 5 innermost layers = pixel detectors
 - Novel serial powering scheme, bi-phase CO_2 cooling, ...

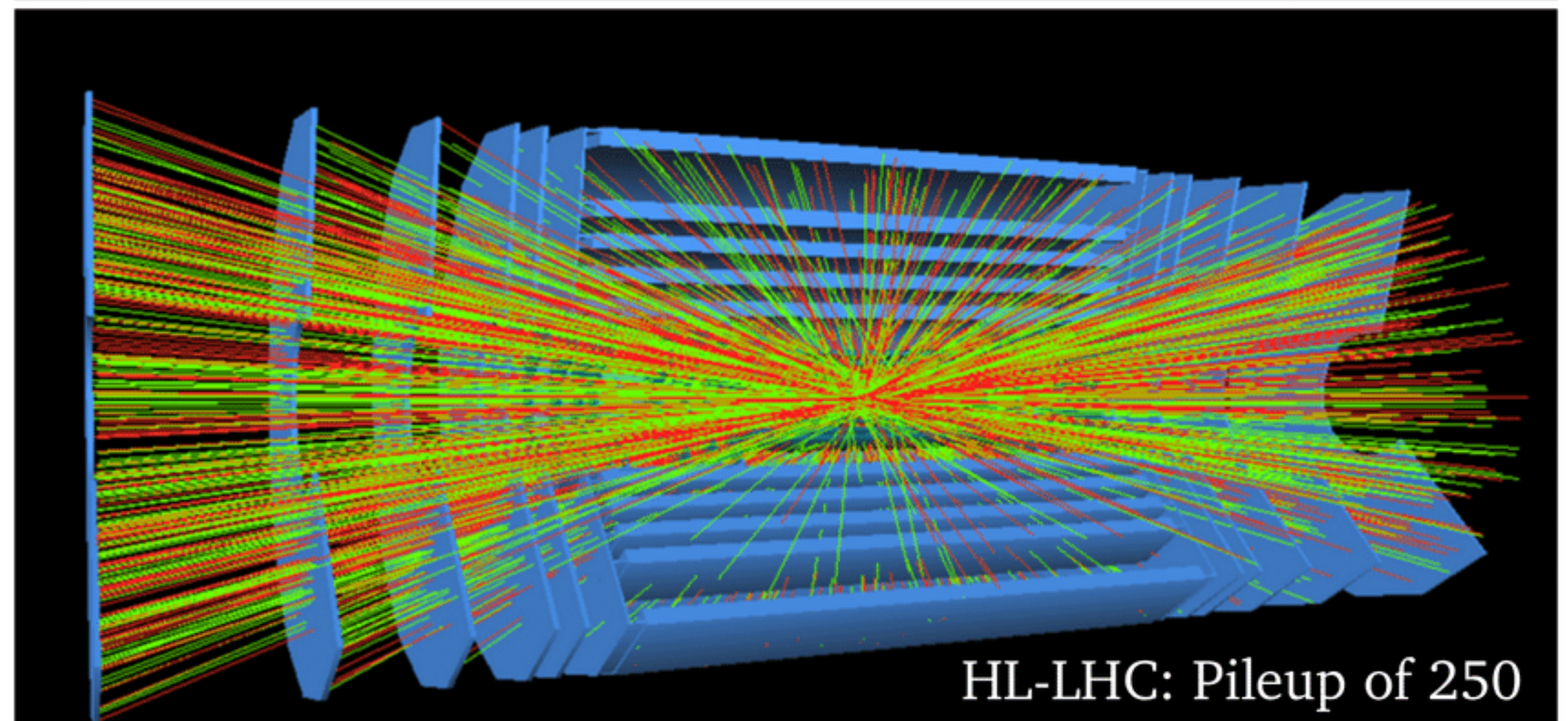
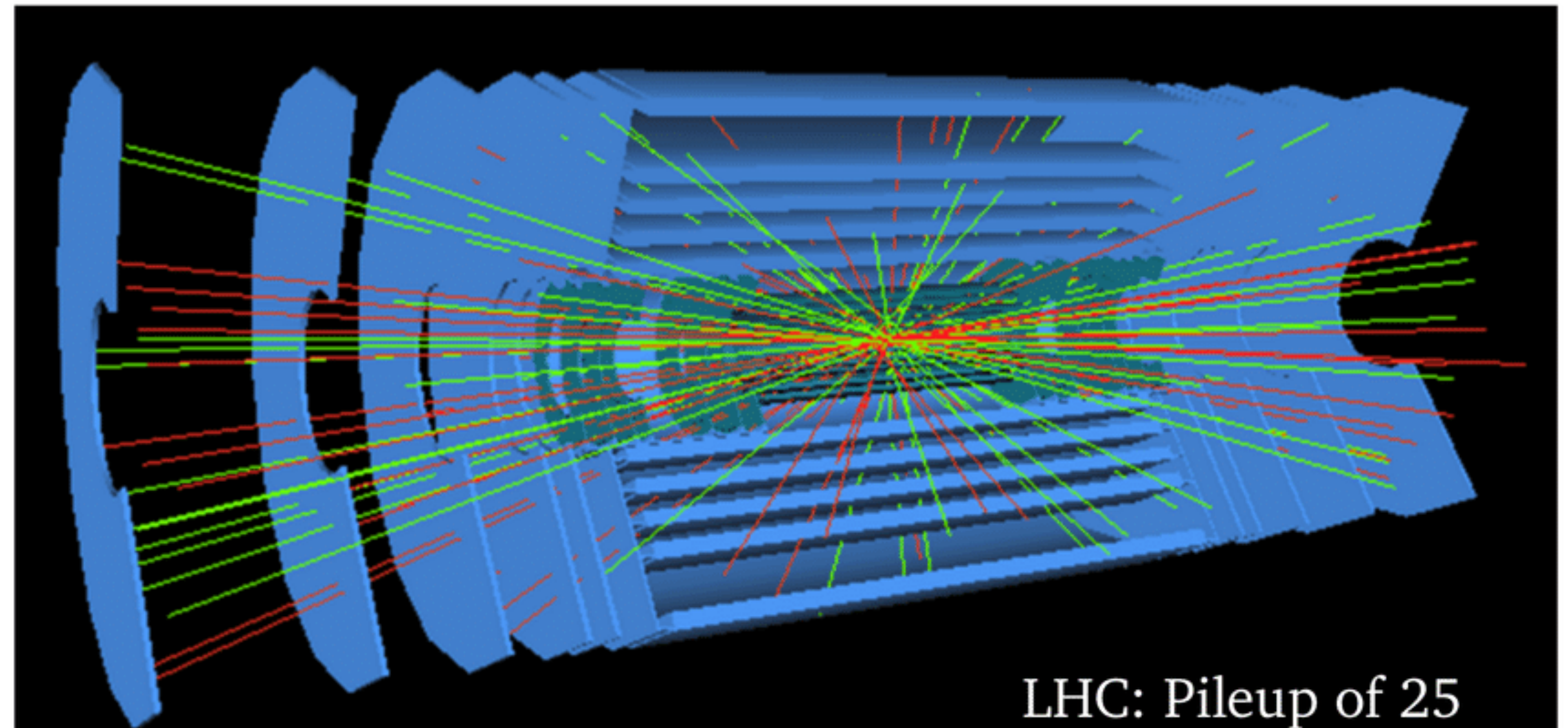

No ITk = no search for $HH \rightarrow bb\tau\tau$

The search for $HH \rightarrow bb\tau\tau$ crucially relies on the tracker for b-tagging, hadronic τ -lepton ID

→ Wanted to get involved!

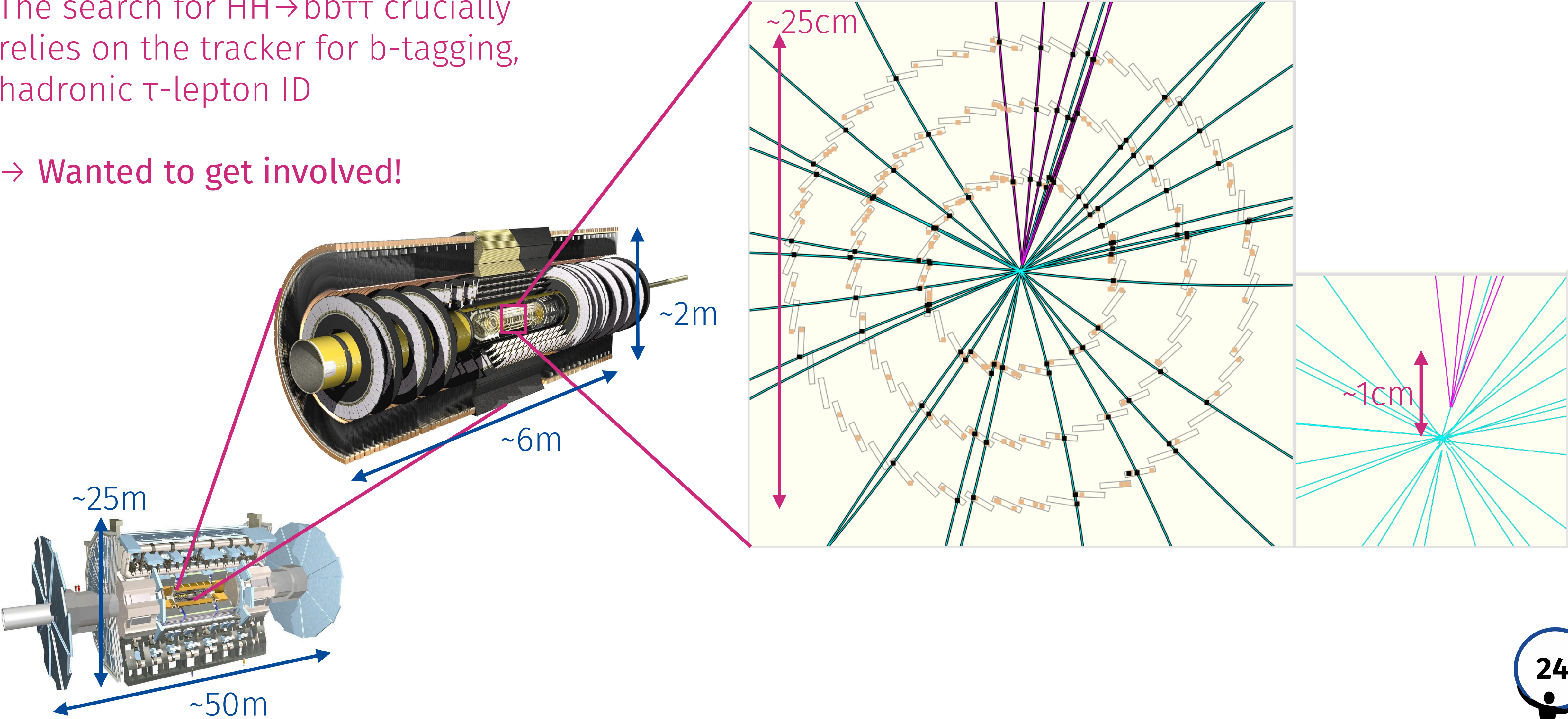

This seminar: 2 snapshots of my work ...

... all aimed to increase resolution

1. Measuring the shape of the Higgs potential

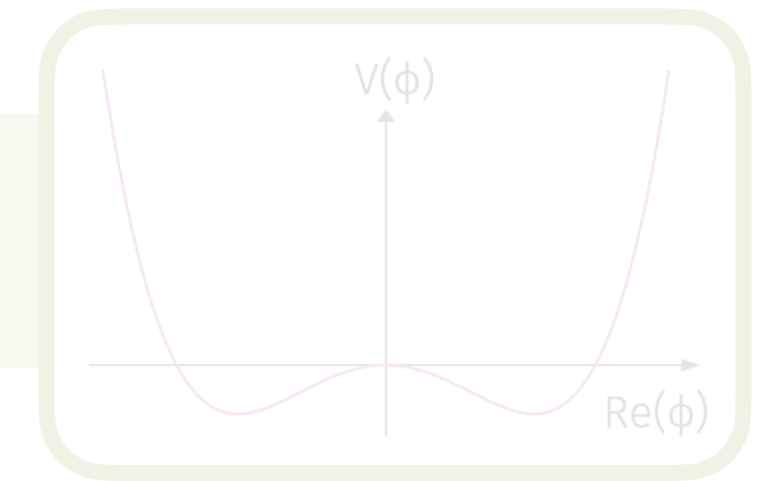

2. Building the new ATLAS pixel detector

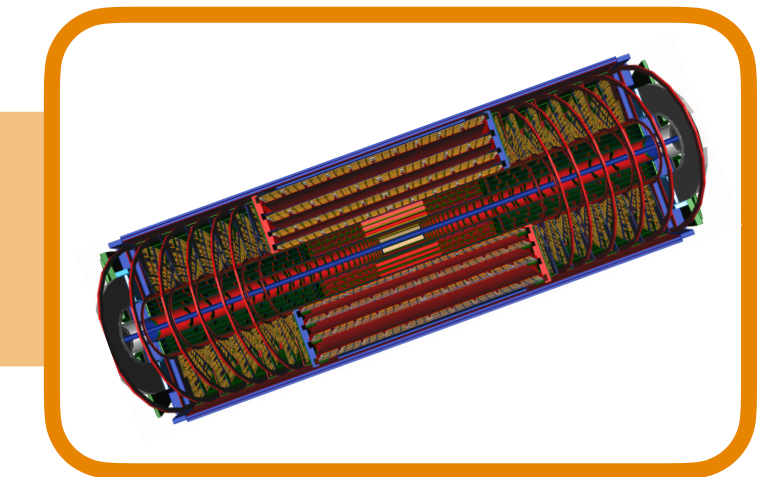

From modules to the detector

- ▶ Need an intermediate step between individual module testing and building a full detector → **prototypes**

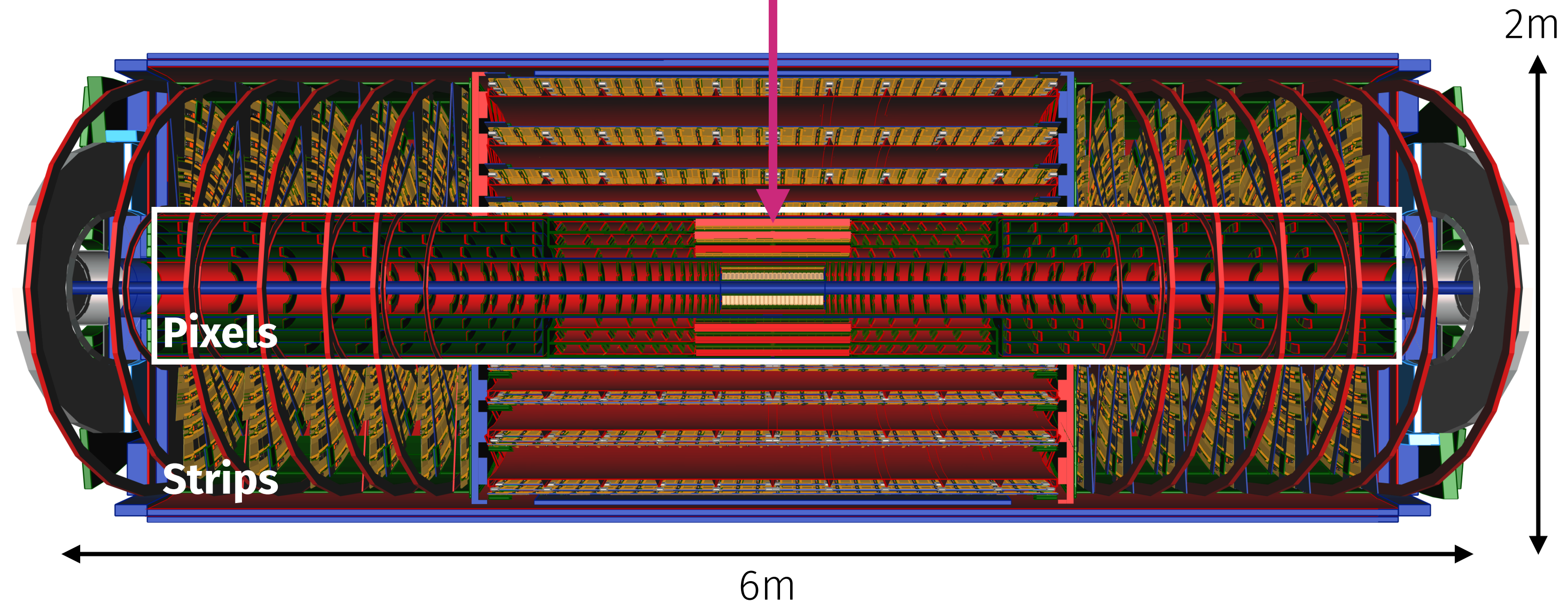
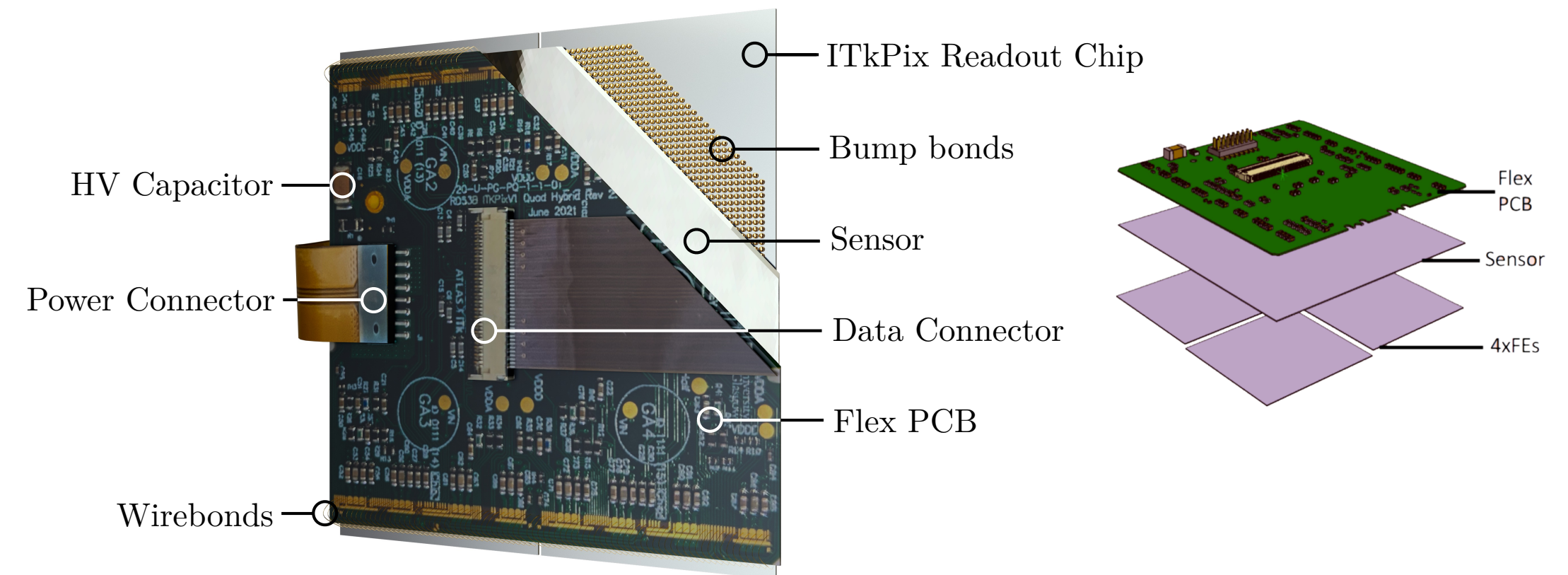

From modules to the detector via prototypes

- ▶ Need an intermediate step between individual module testing and building a full detector → **prototypes**
- ▶ **Largest structure of ITk pixels that we could operate back then**
 - 18 quad modules
 - ~3% of the third pixel barrel layer, ~0.1% of the total detector

Many testing opportunities:

- Detect damages during loading procedure
- Test in realistic environment [services, readout system, interlock, detector control system, ...]

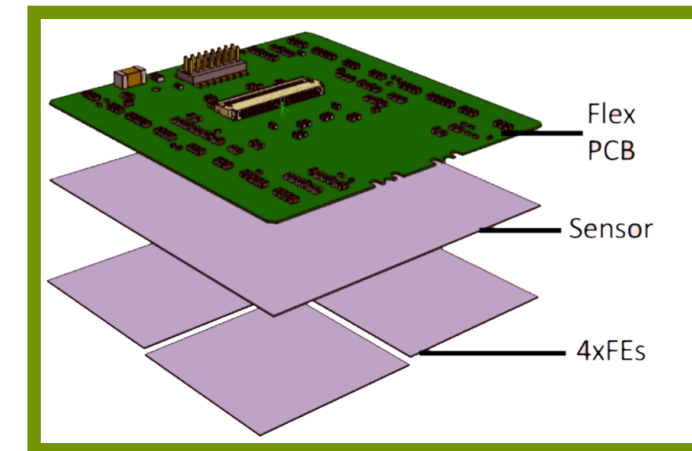

Local support prototype in the SR1 RadLab at Point 1, CERN

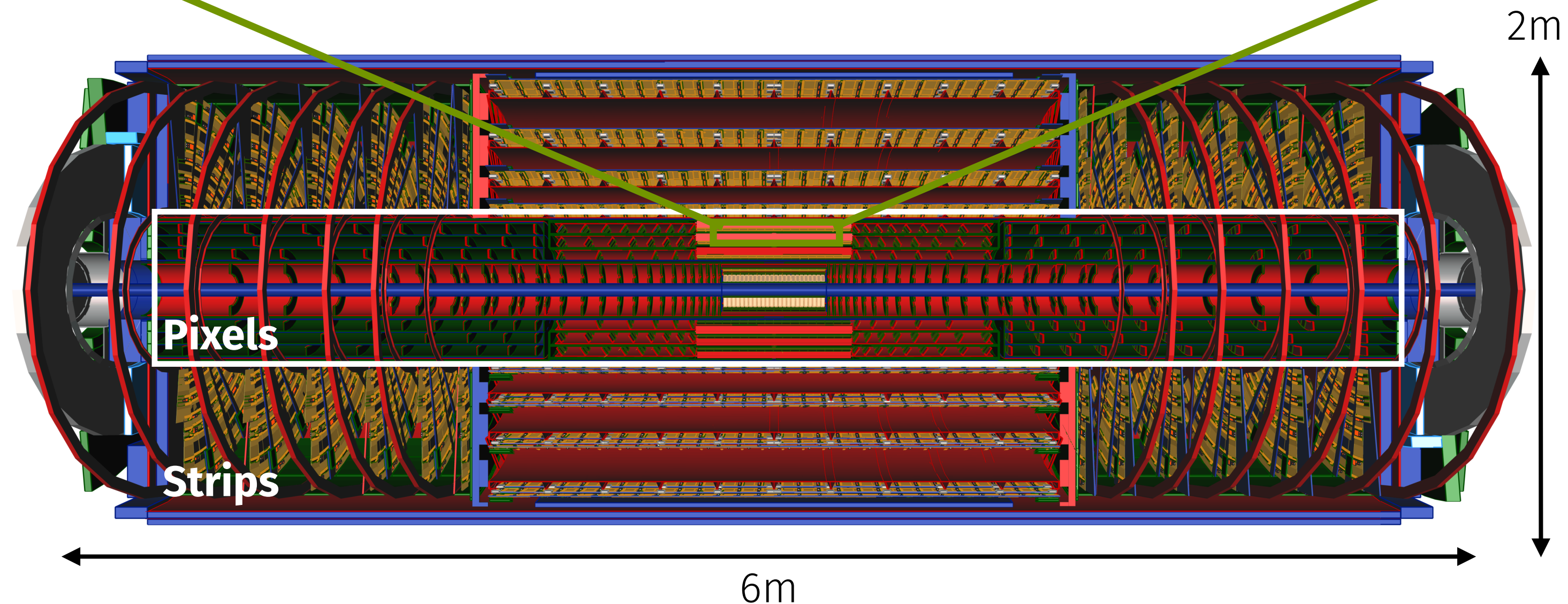
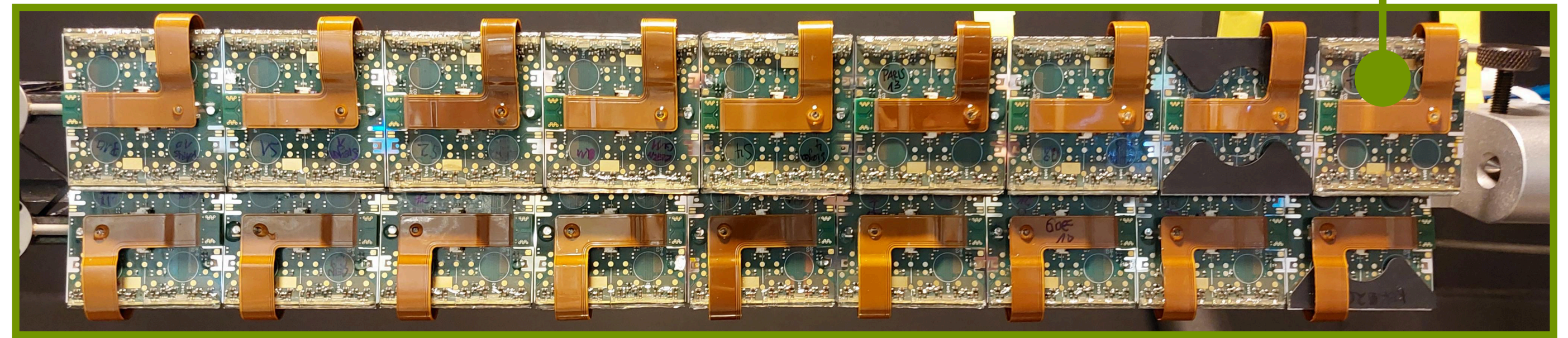

The SR1 pixel demonstrator at CERN

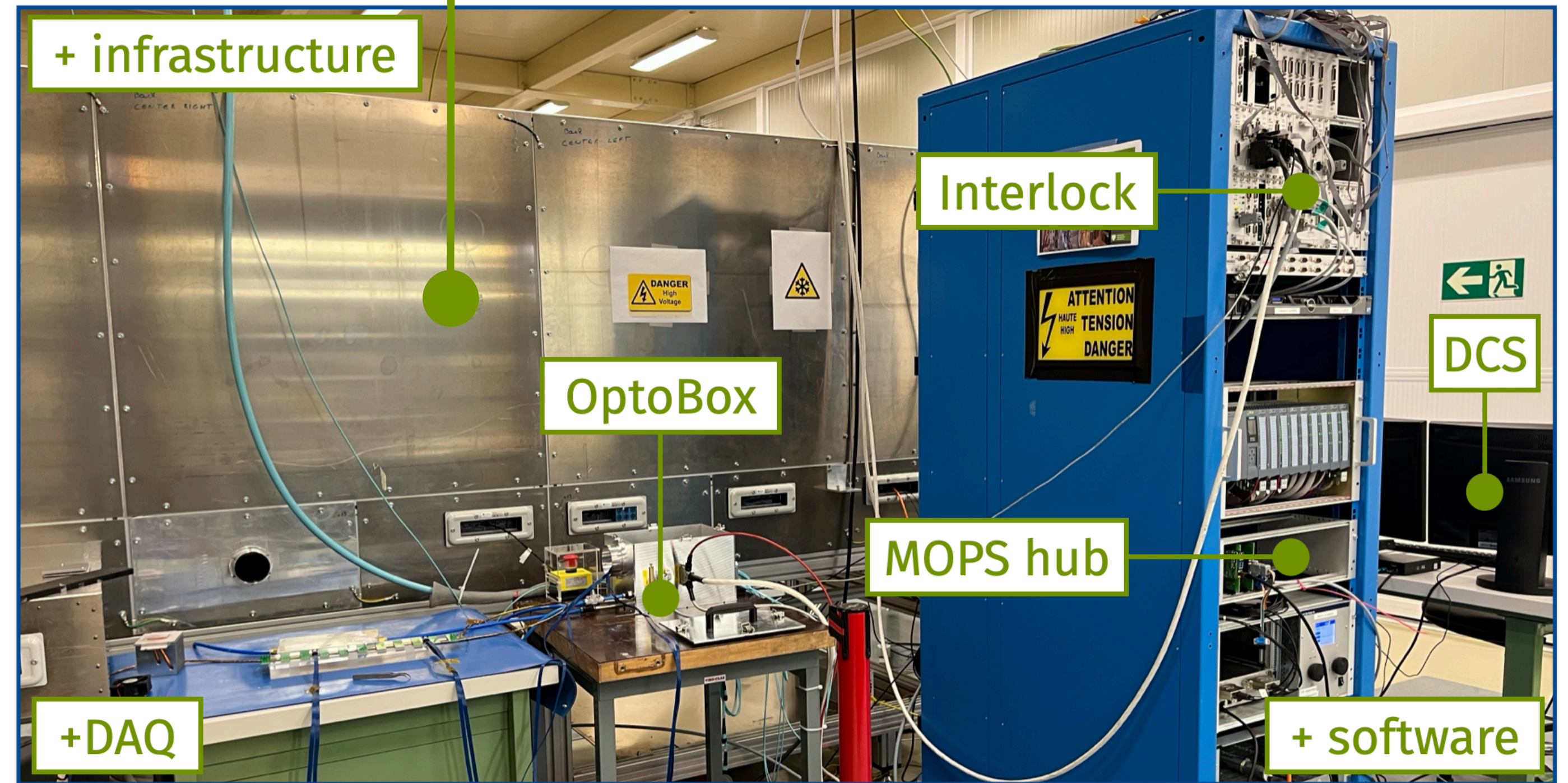
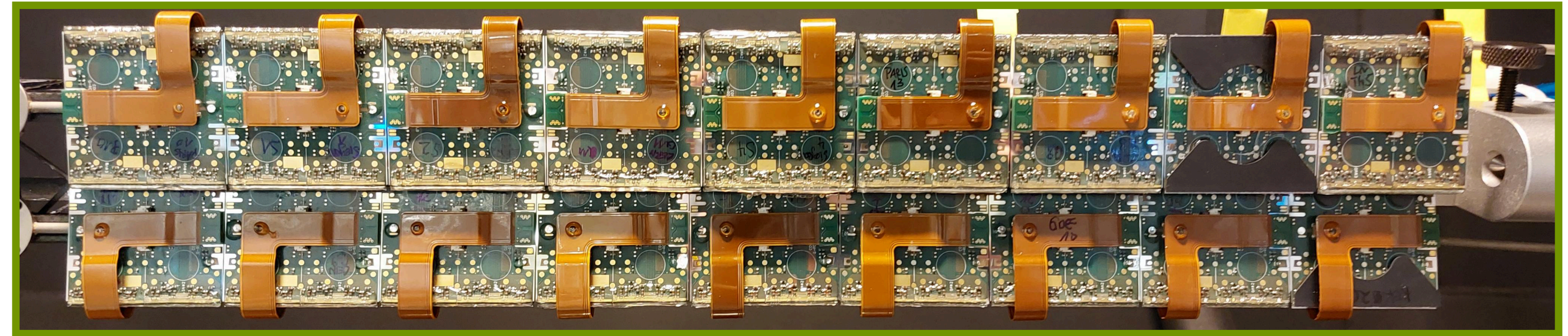
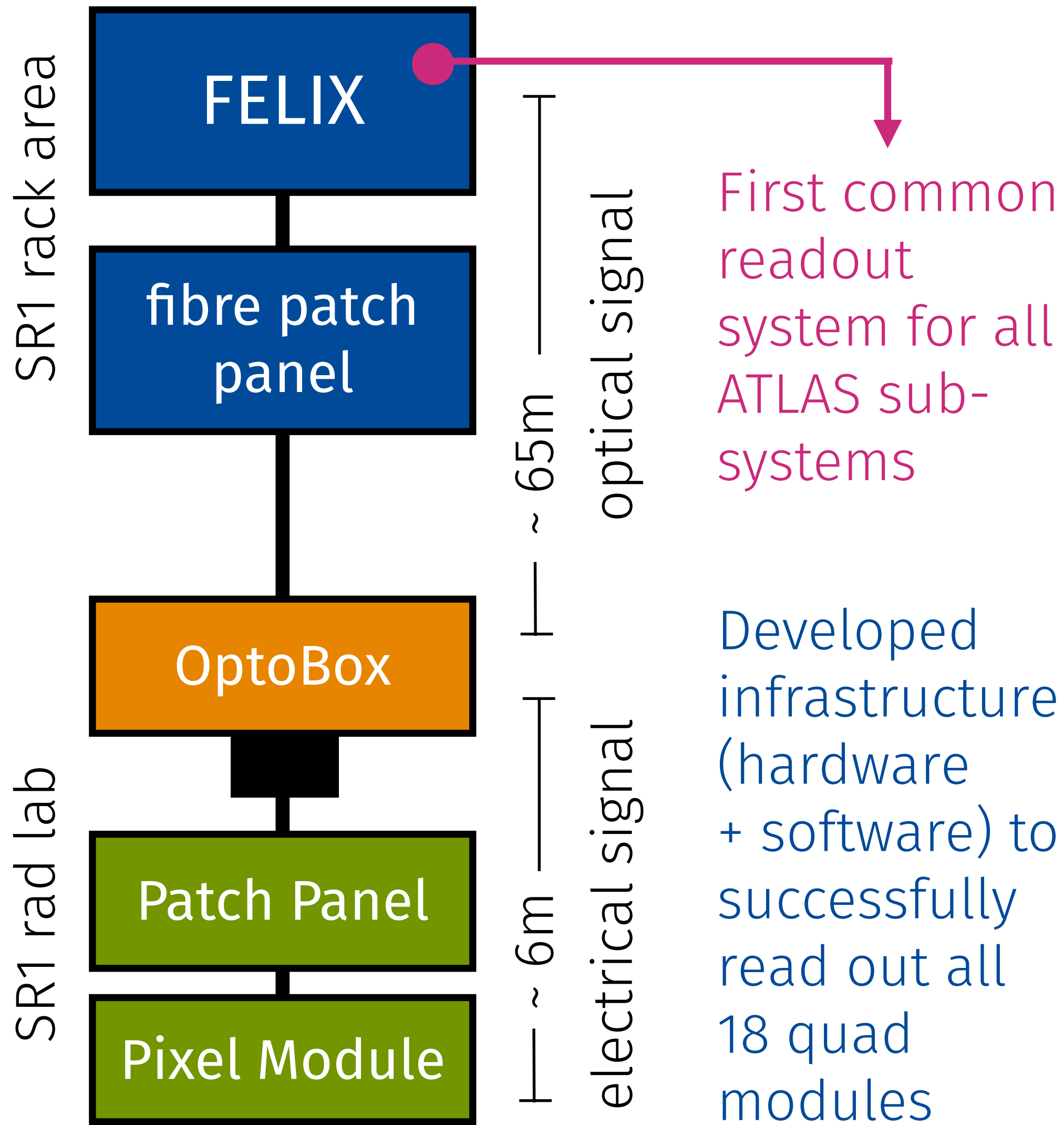

Further developments: multi-module DAQ setup

- ▶ **Aim:** build an additional test bench for development of the data acquisition software

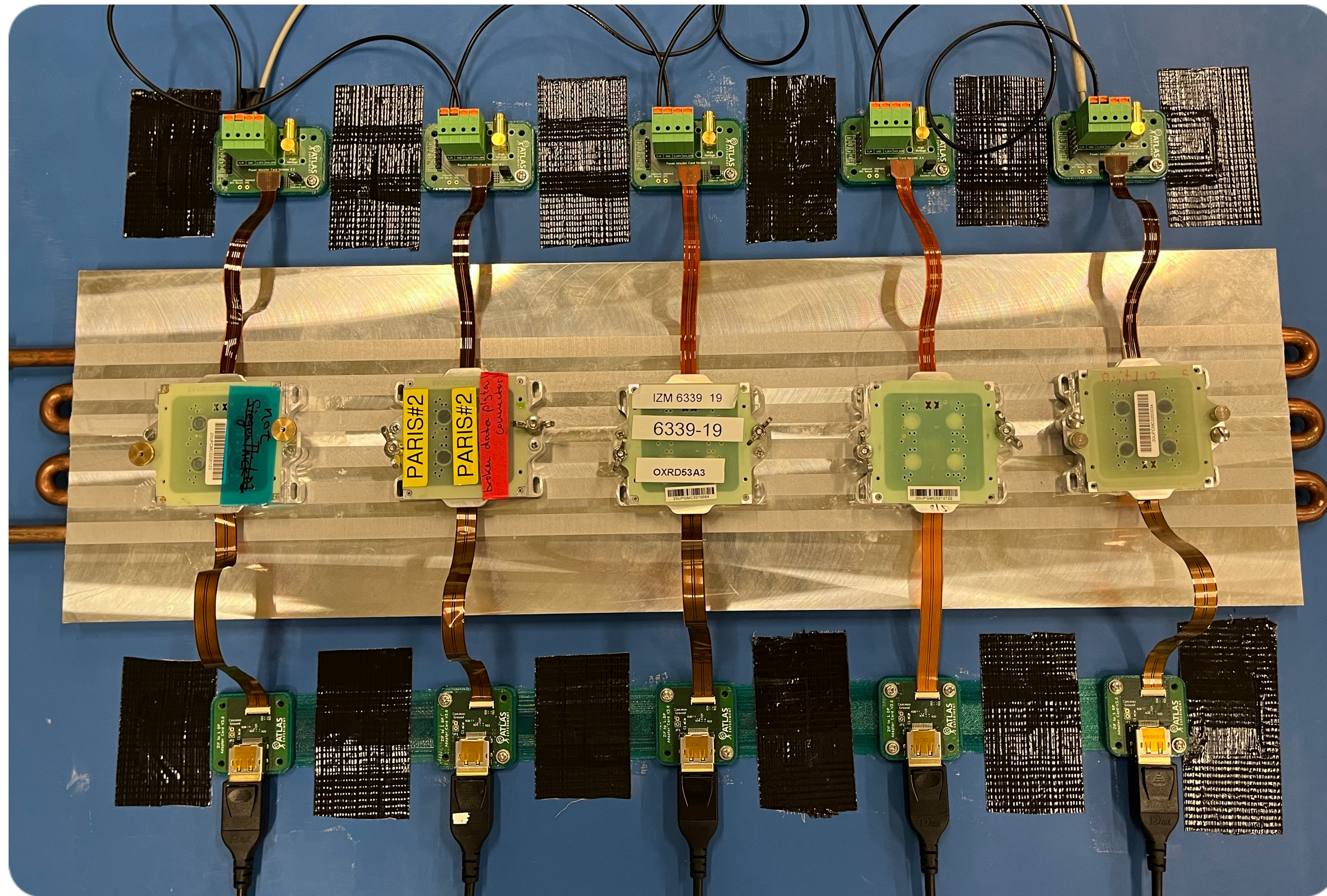

Benchmarking electrical testing time

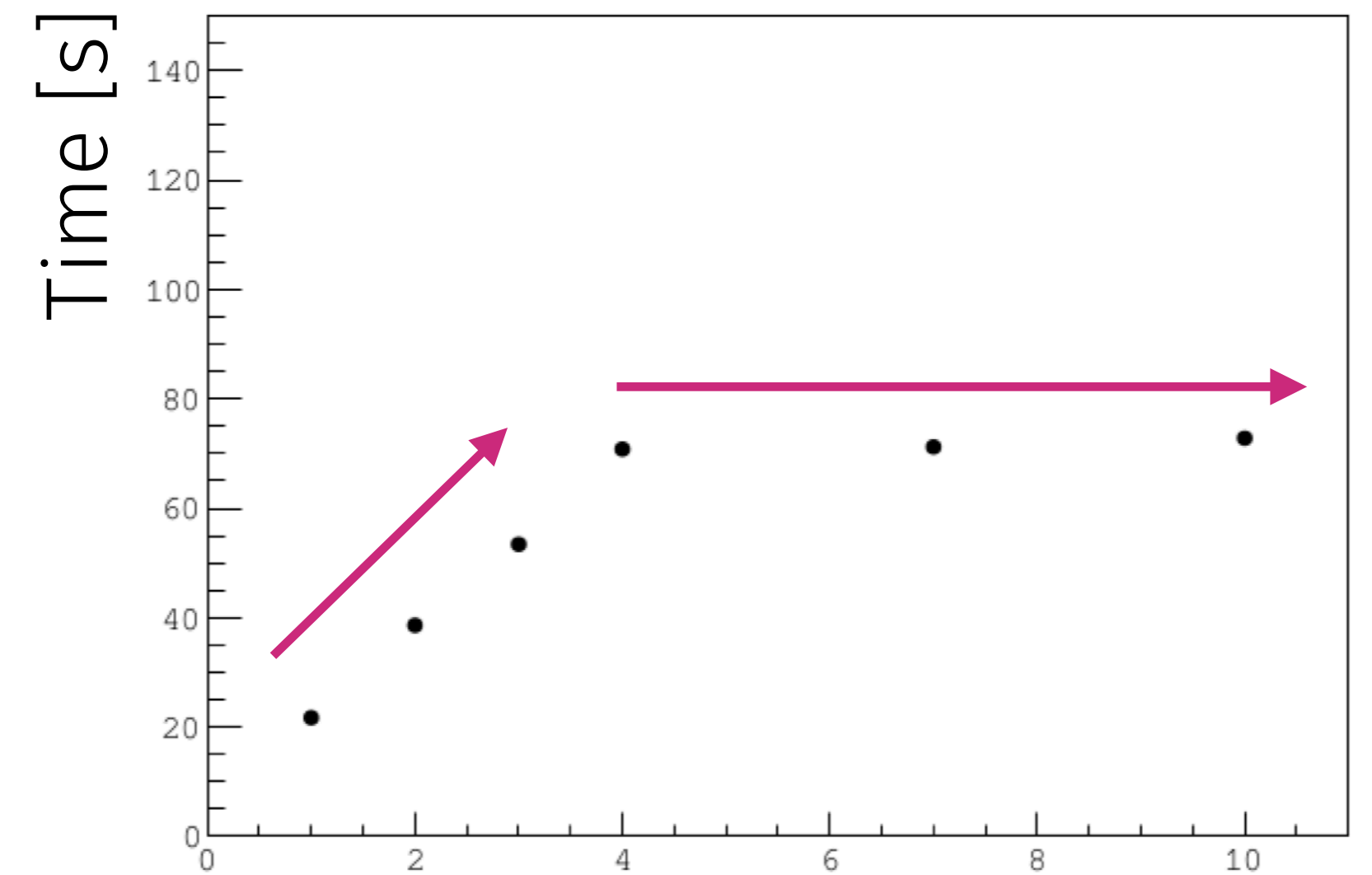

Number of read-out chips

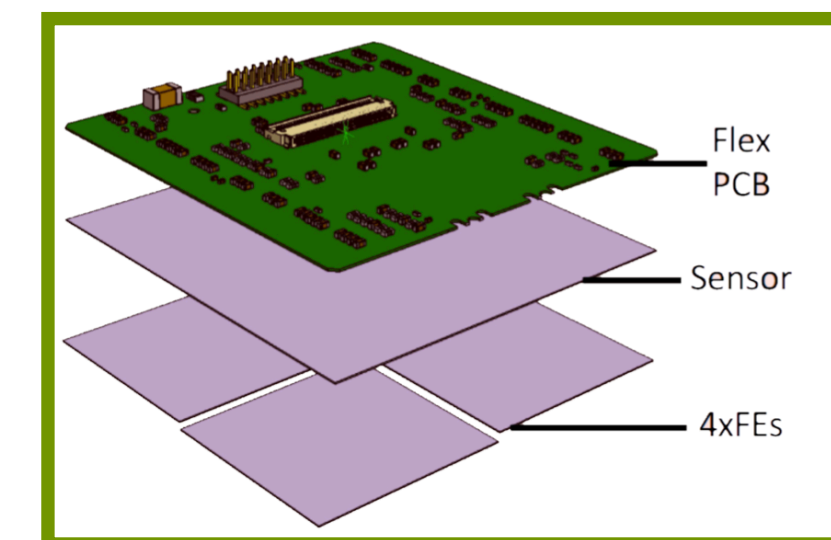

- ▶ Setup still in use at CERN today!

Modules, patch panels, cables, supports, ...

... there's a lot of **material** going in a detector

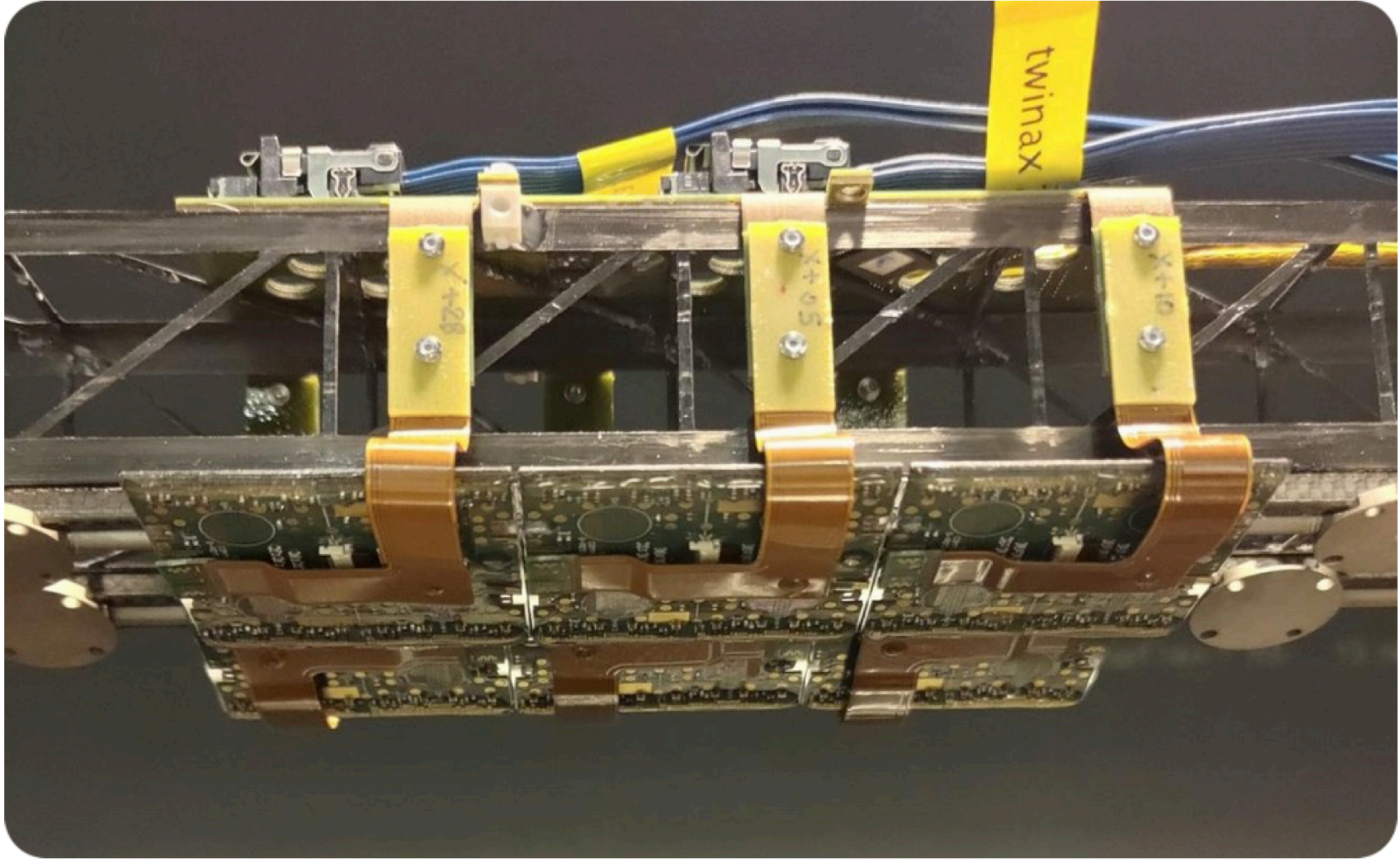
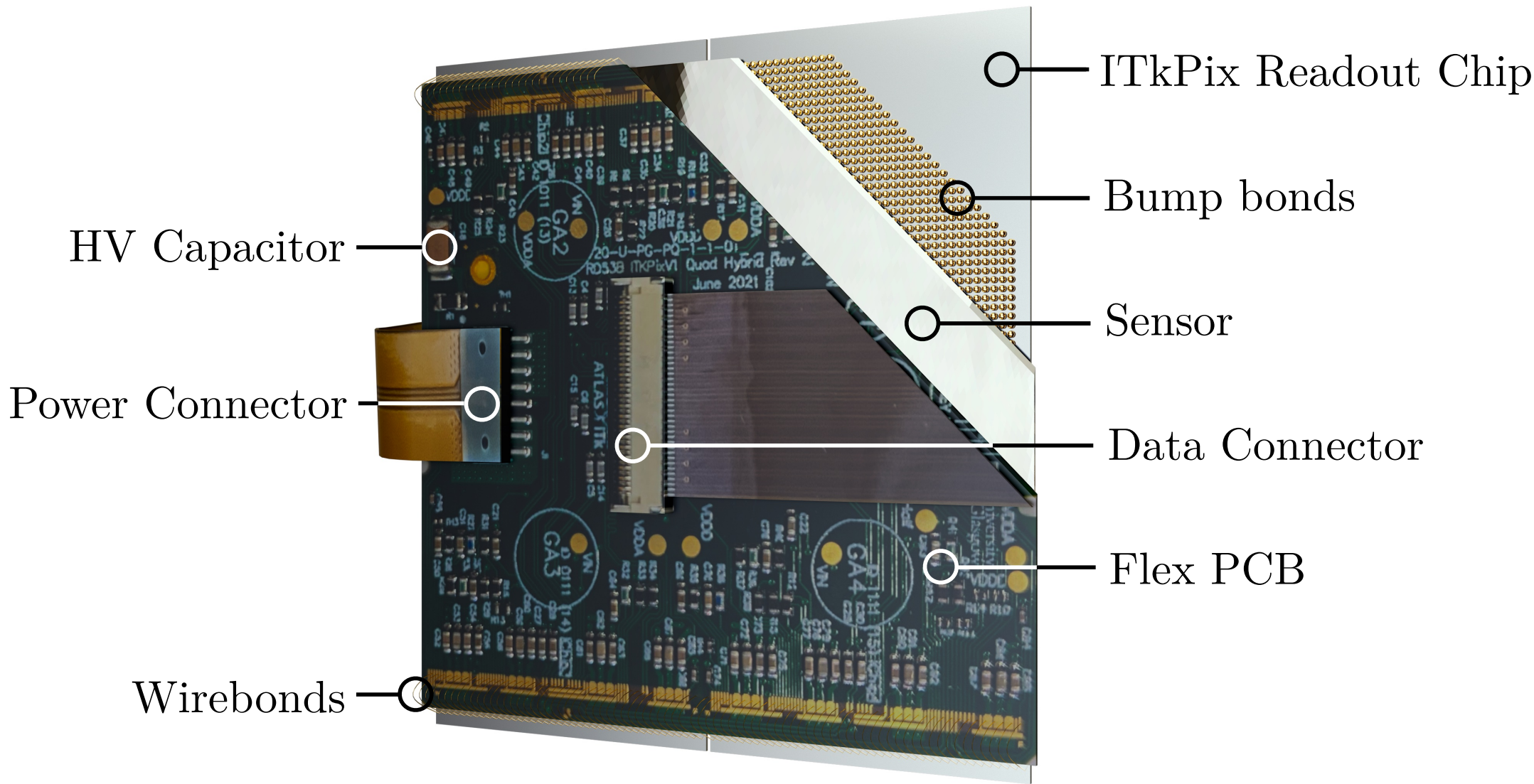

Keep your material budget low!

- ▶ Detector material impacts our physics performance: **minimisation of material** and **precise knowledge** of the detector makeup are critical for success
→ not an easy task

Example: vertexing

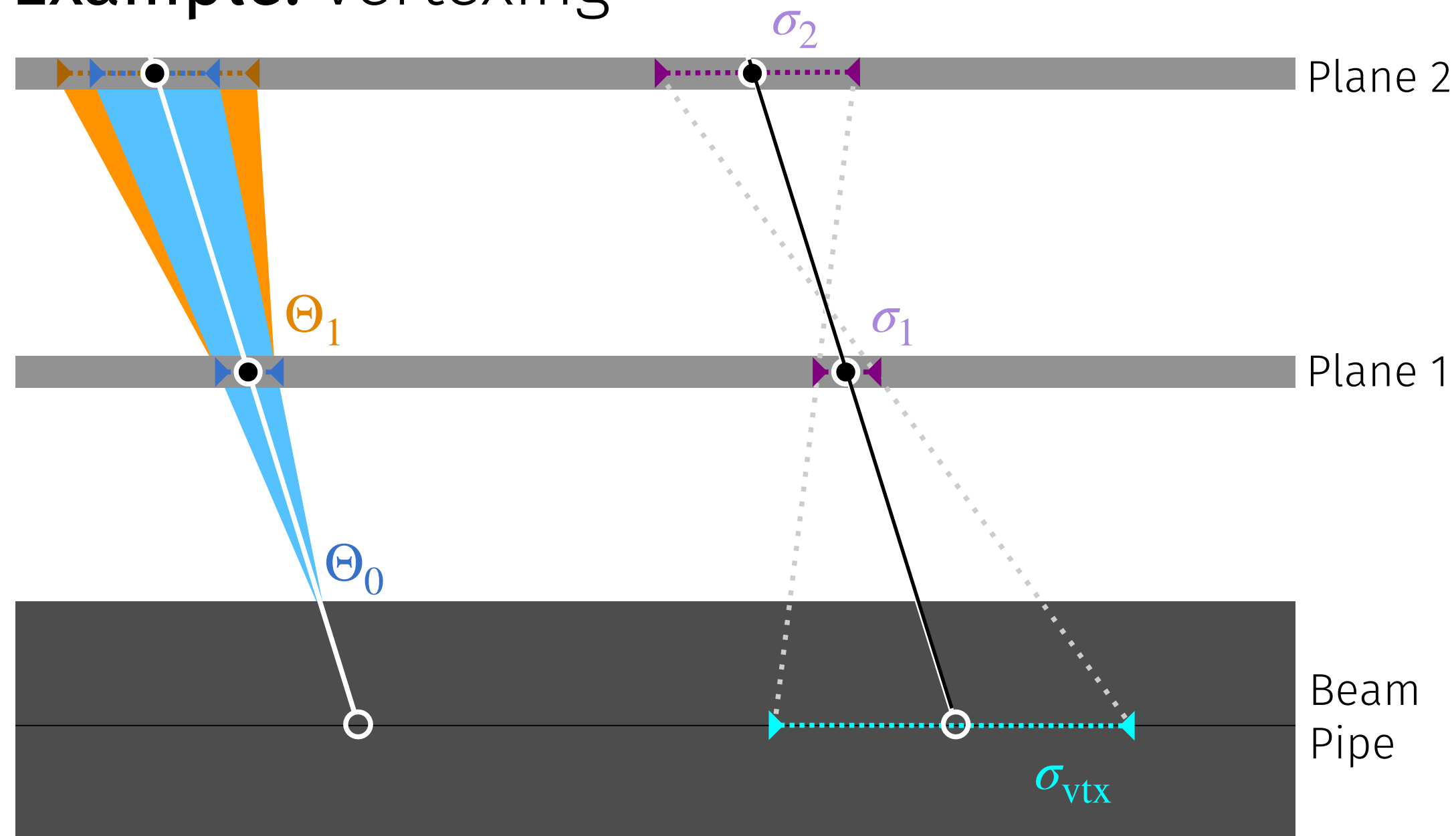

Initial design (TDR)

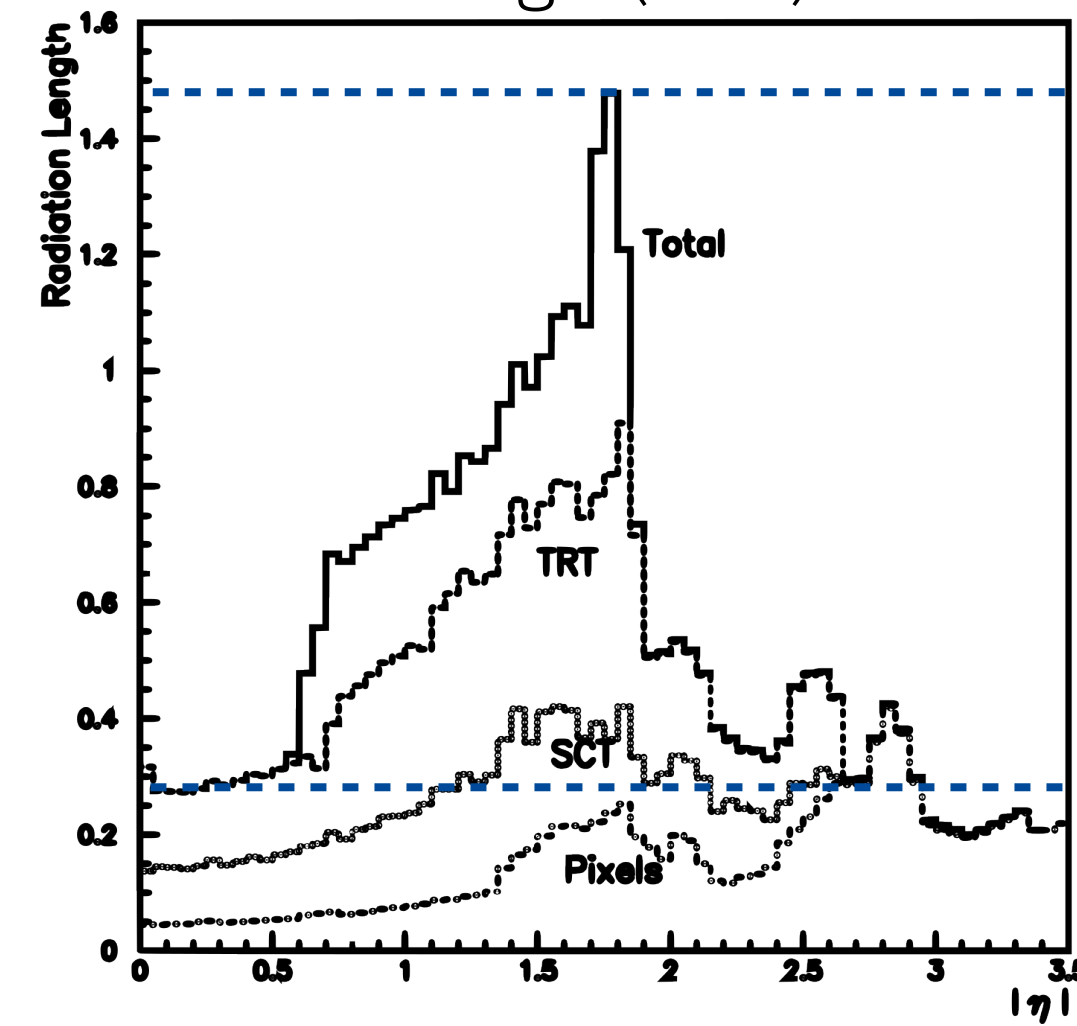

Final design

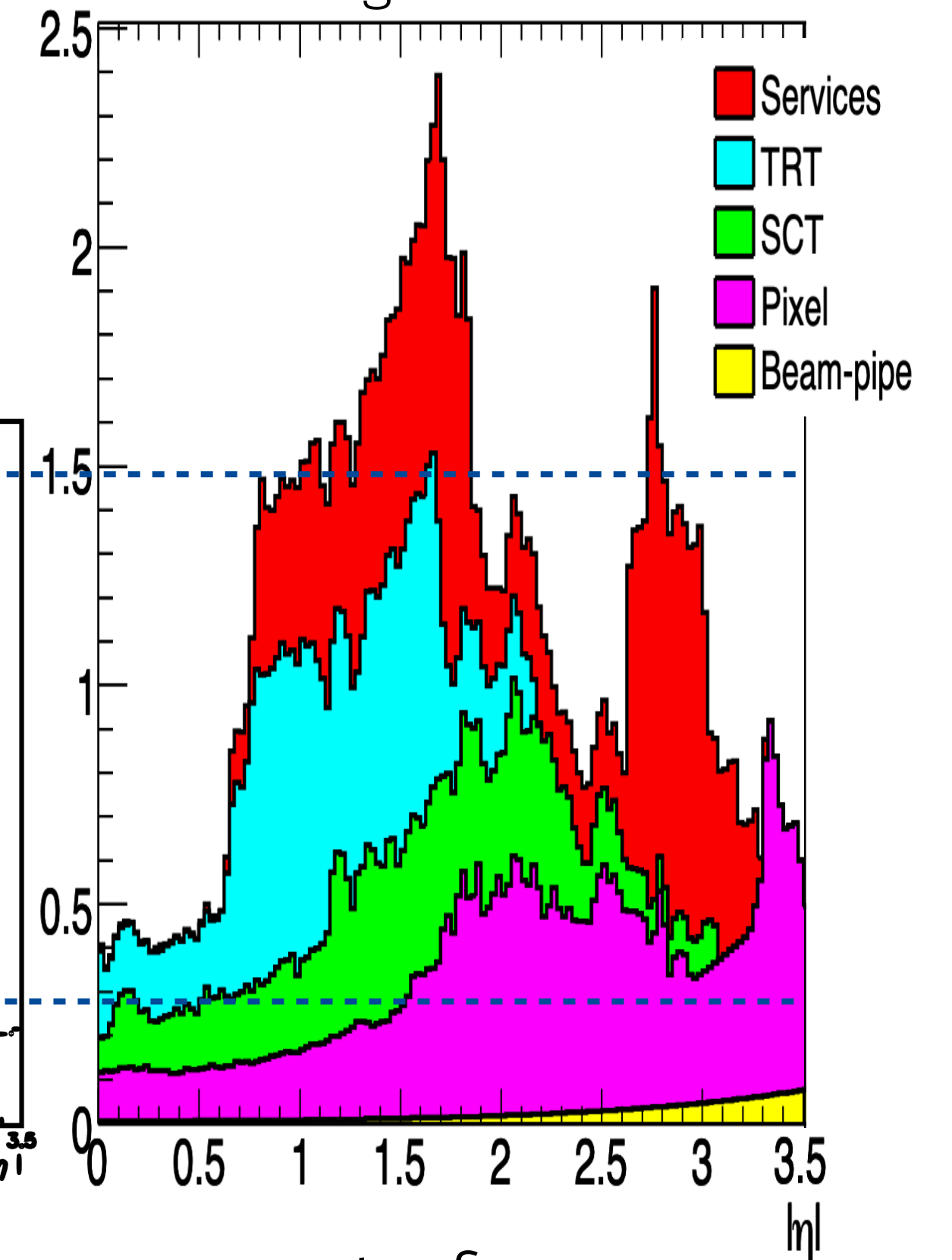

- ▶ **Idea:** infer the material content (the fractional radiation length x/X_0) via the amount of multiple scattering → started as a summer student project with S. Koch (then Oxford, now CERN)

Measuring x/X_0 using multiple scattering!

Starting point: operational ITkPix quad module mounted on a movable x-y stage

→ built a beam telescope with low material reference planes around it

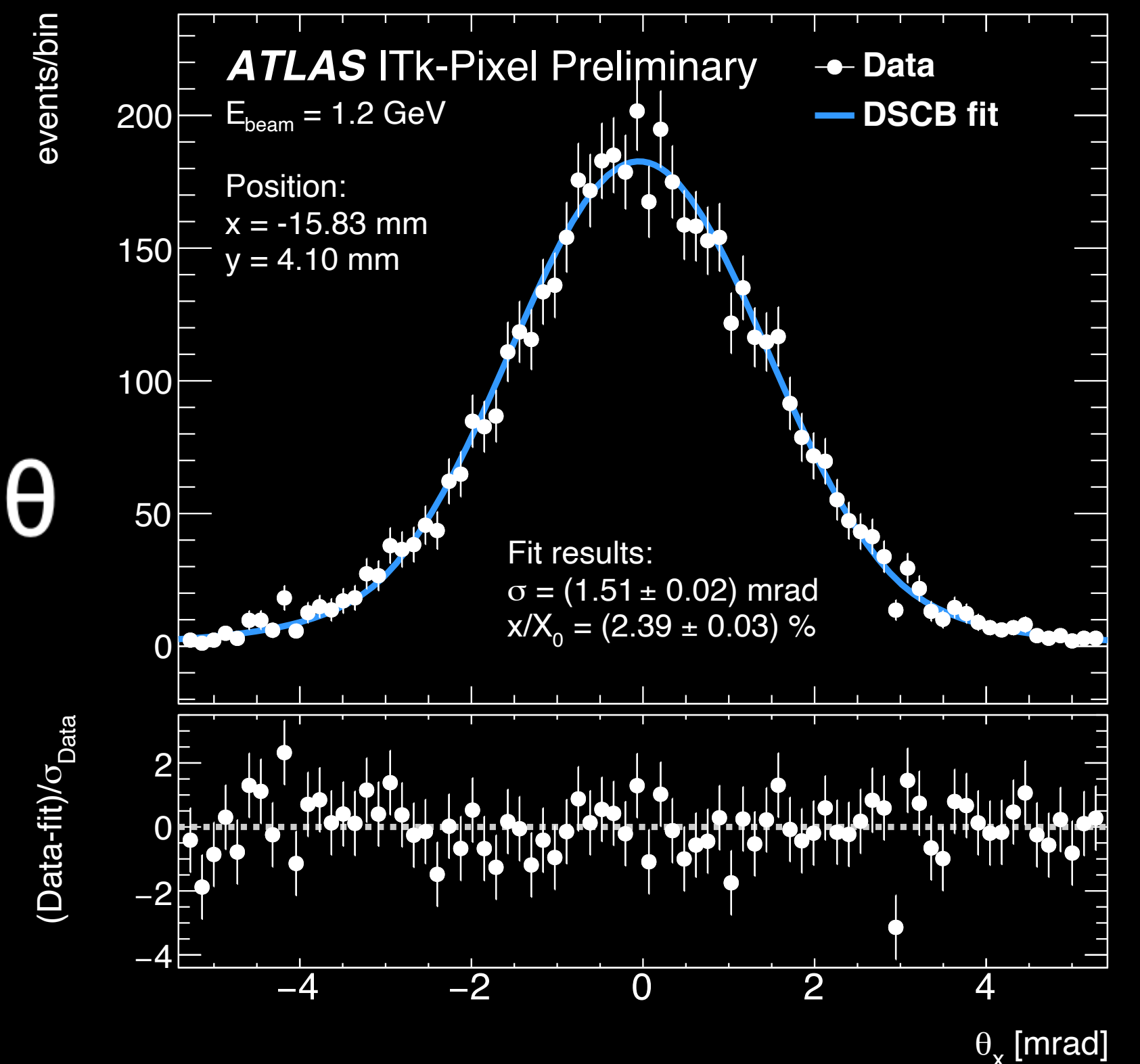
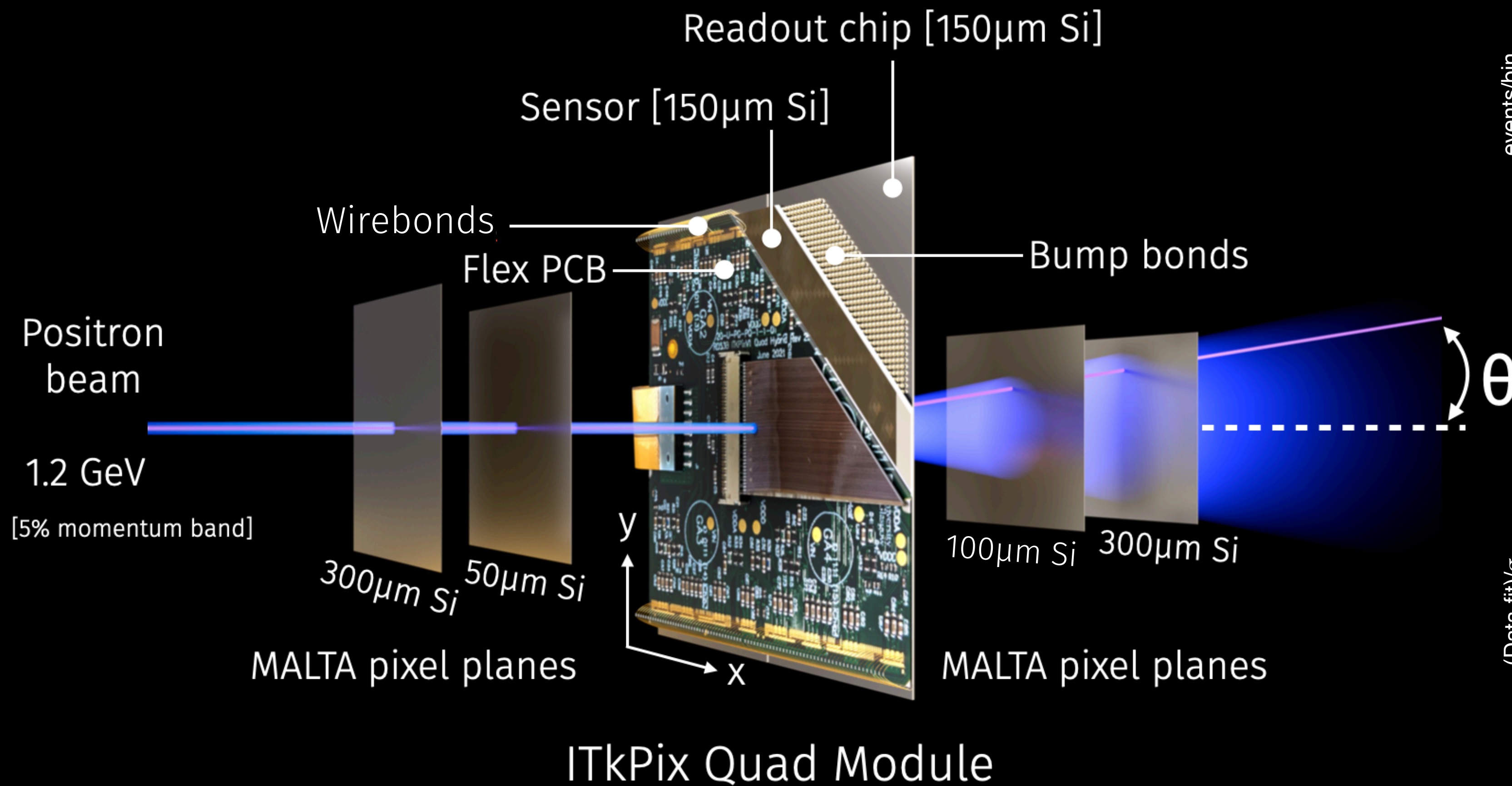

The MONSTAR telescope

- ▶ The beam telescope needed to have low material content itself, to minimize multiple scattering in the reference planes → MALTA monolithic pixel sensors (down to 50μm thick)
- ▶ Long enough to resolve the scatter angles → 2m
- ▶ Triggering on reference plane coincidence
- ▶ Active DUT mounted on a linear stage to be able to scan large areas

Telescope:

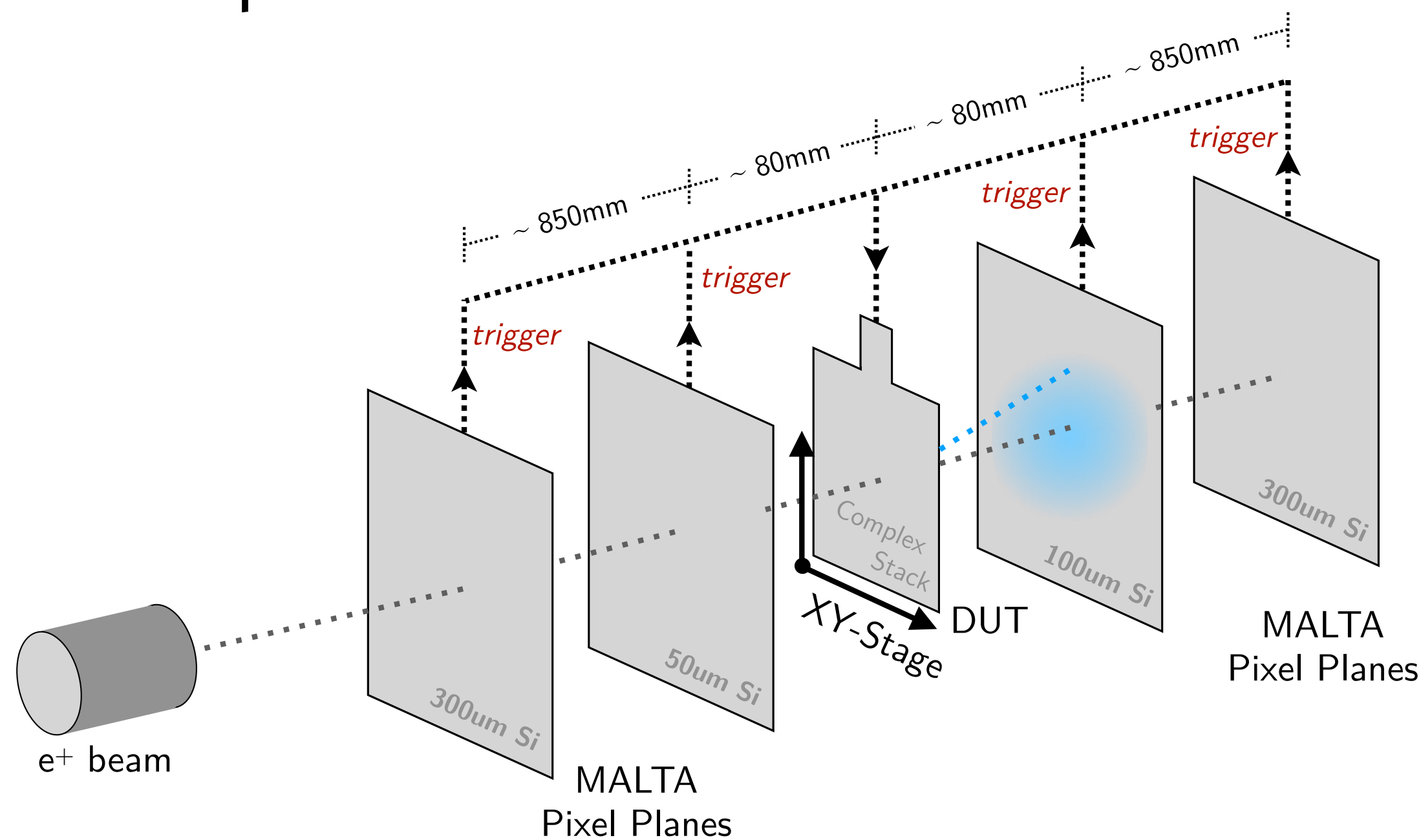

Data acquisition chain:

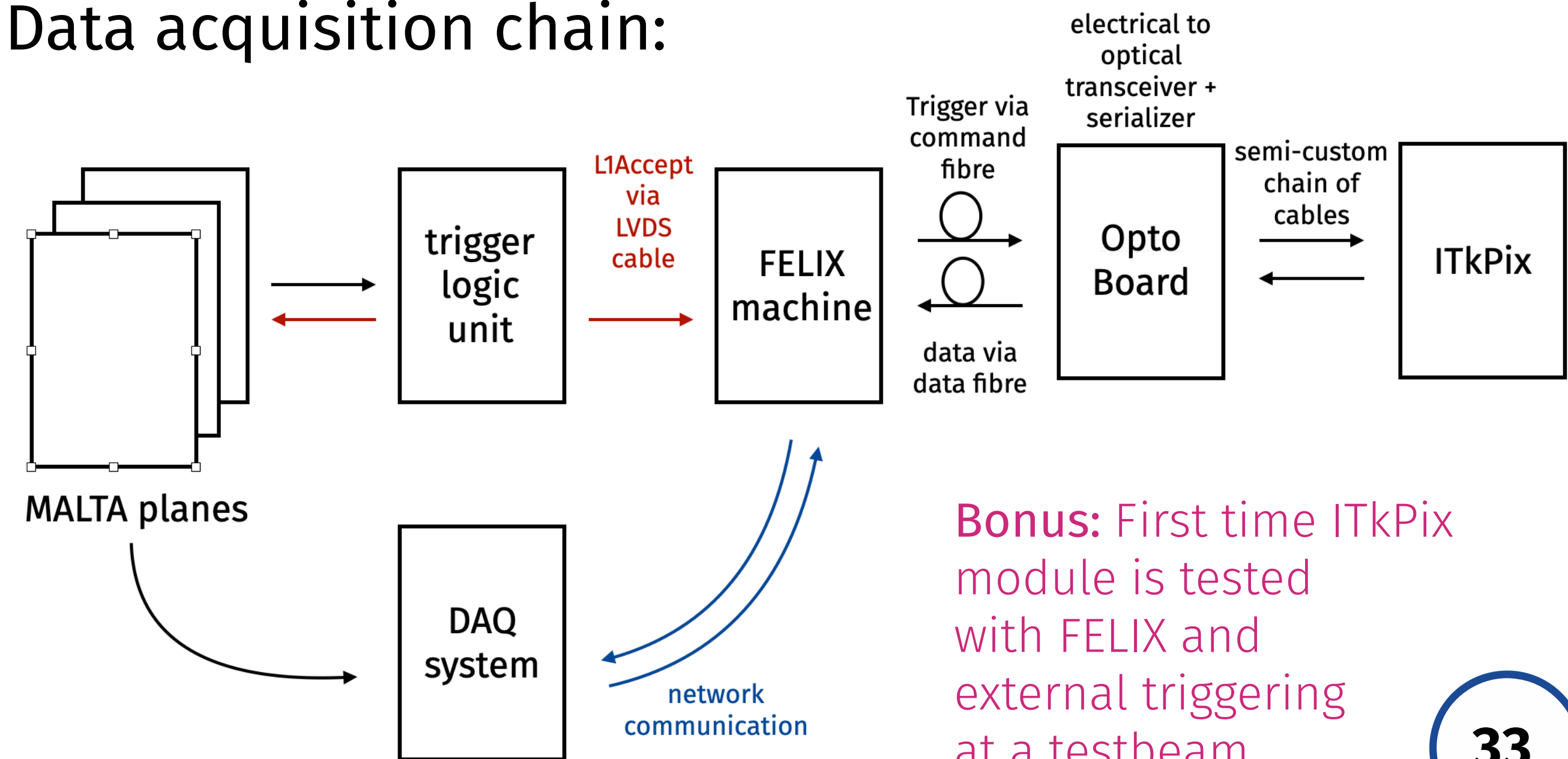

Bonus: First time ITkPix module is tested with FELIX and external triggering at a testbeam

Our setup at the CERN Proton Synchrotron

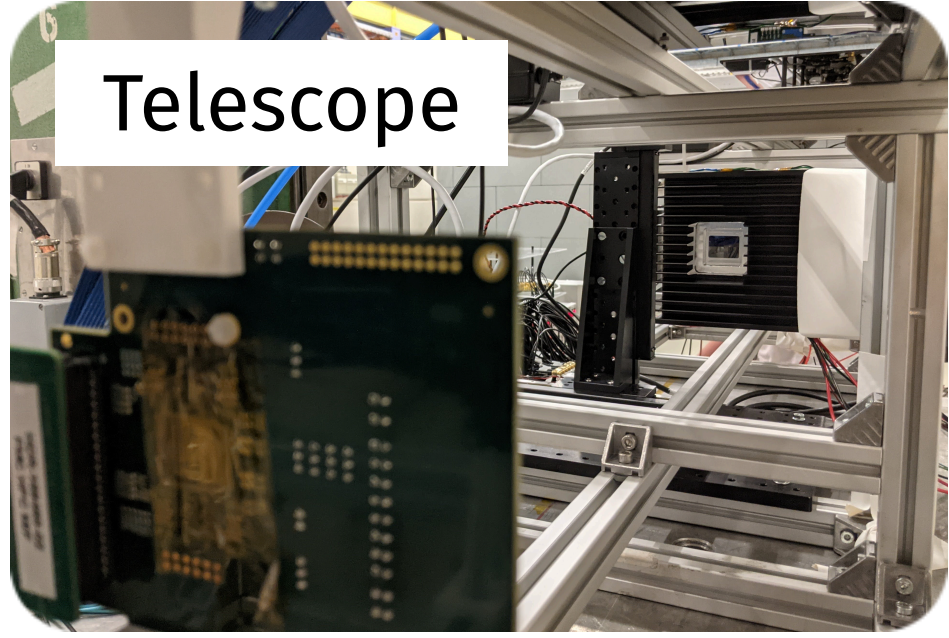
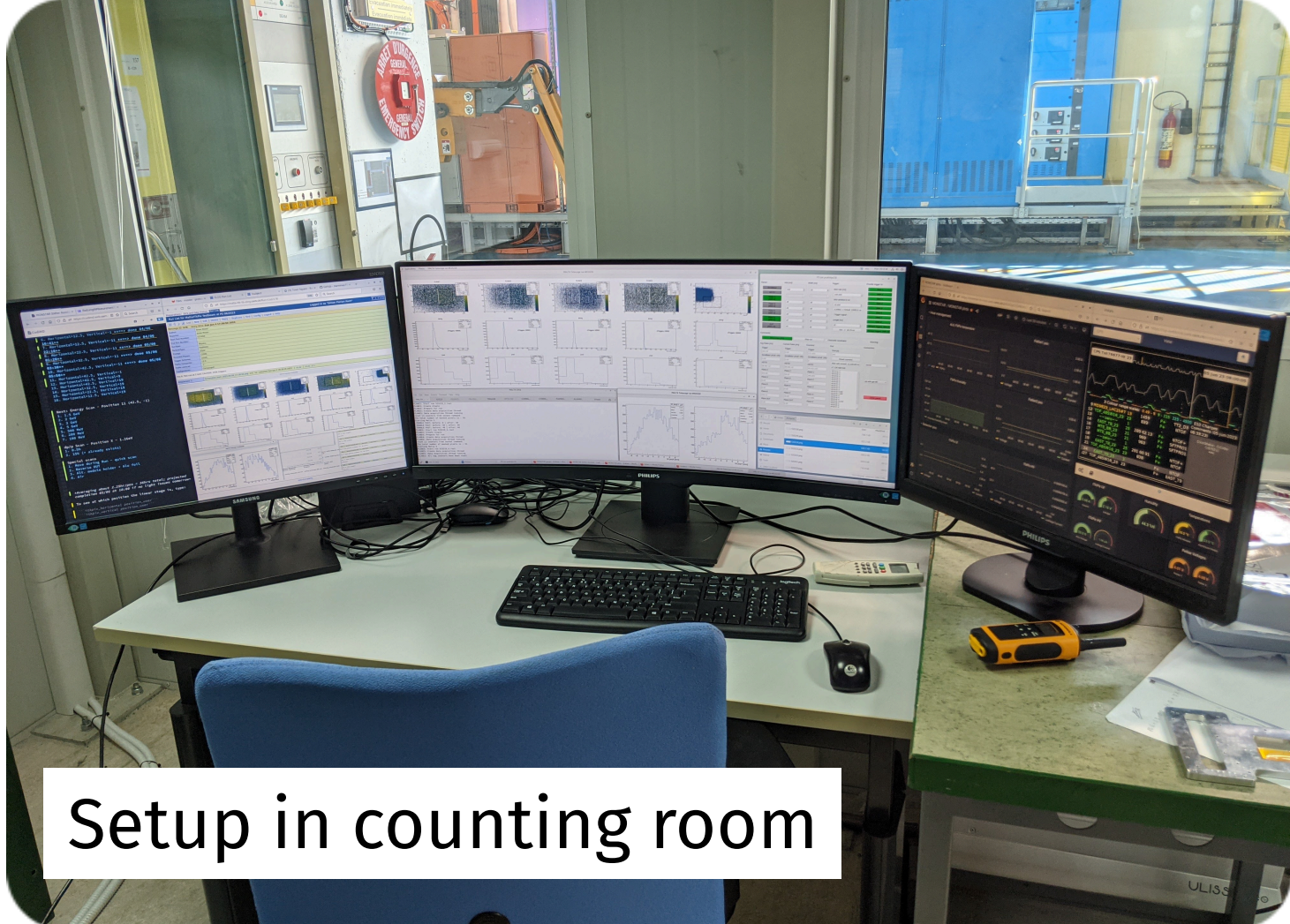
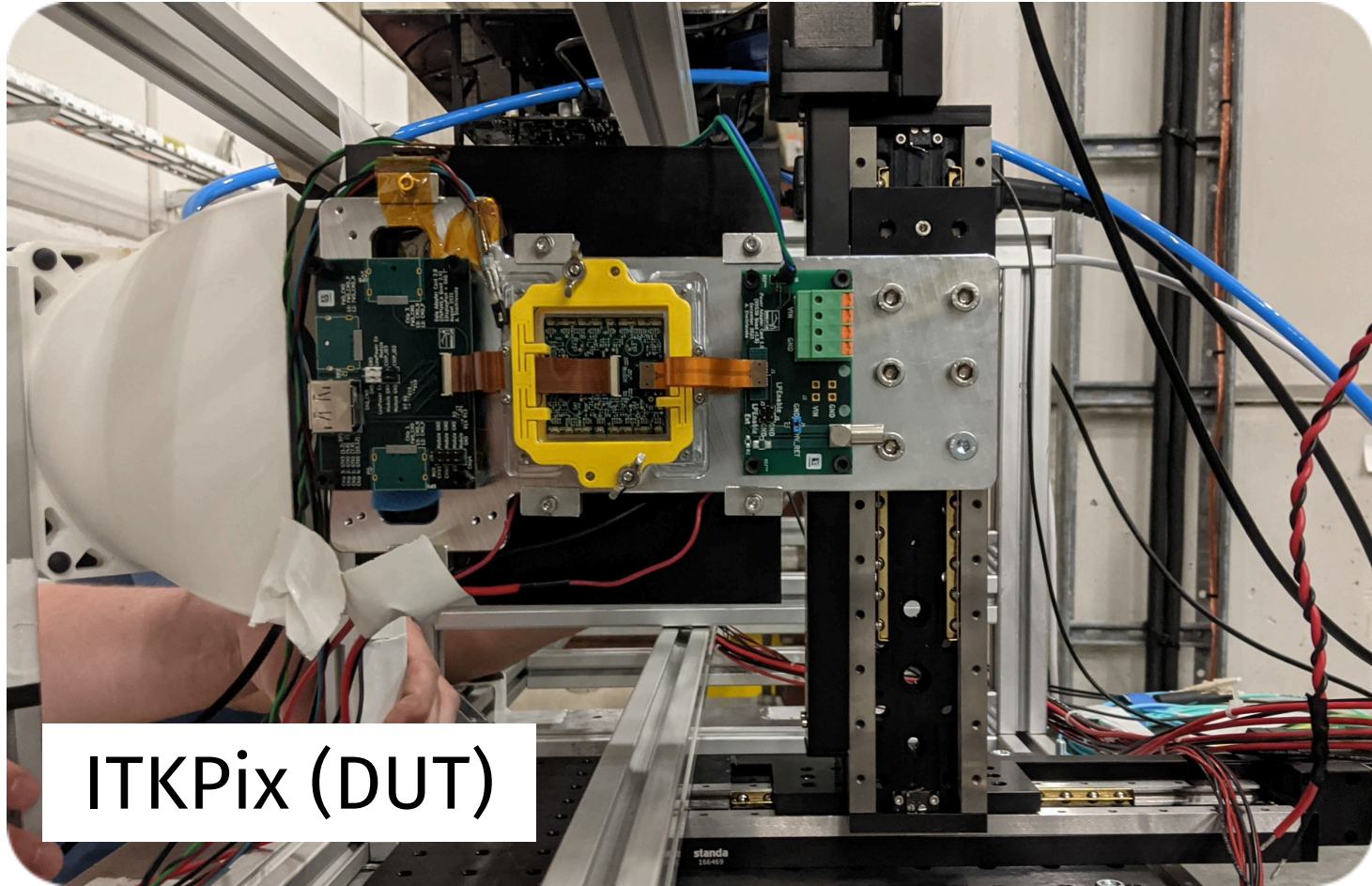
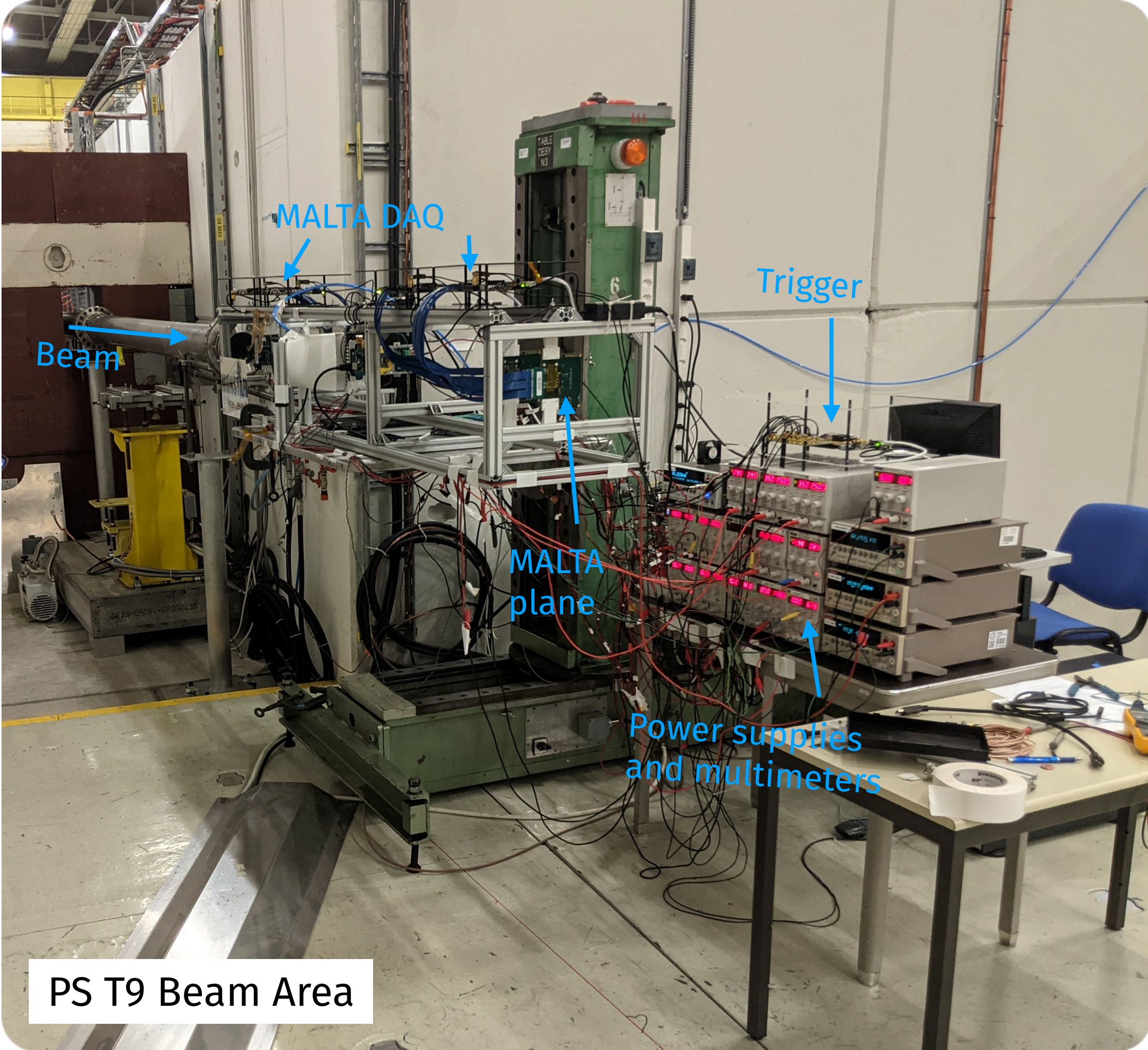

► A huge effort done by a small dedicated team of people!

The measurement results

- The result shows **good agreement** with estimate, mean agrees within uncertainties

Measurement:

ATLAS ITk-Pixel Preliminary

Combined measurement, $E_{\text{beam}} = 1.2 \text{ GeV}$
 $\langle x/X_0 \rangle [\%] = 0.84 \pm 0.01 \text{ (reso.)} \pm 0.11 (E_{\text{beam}})$

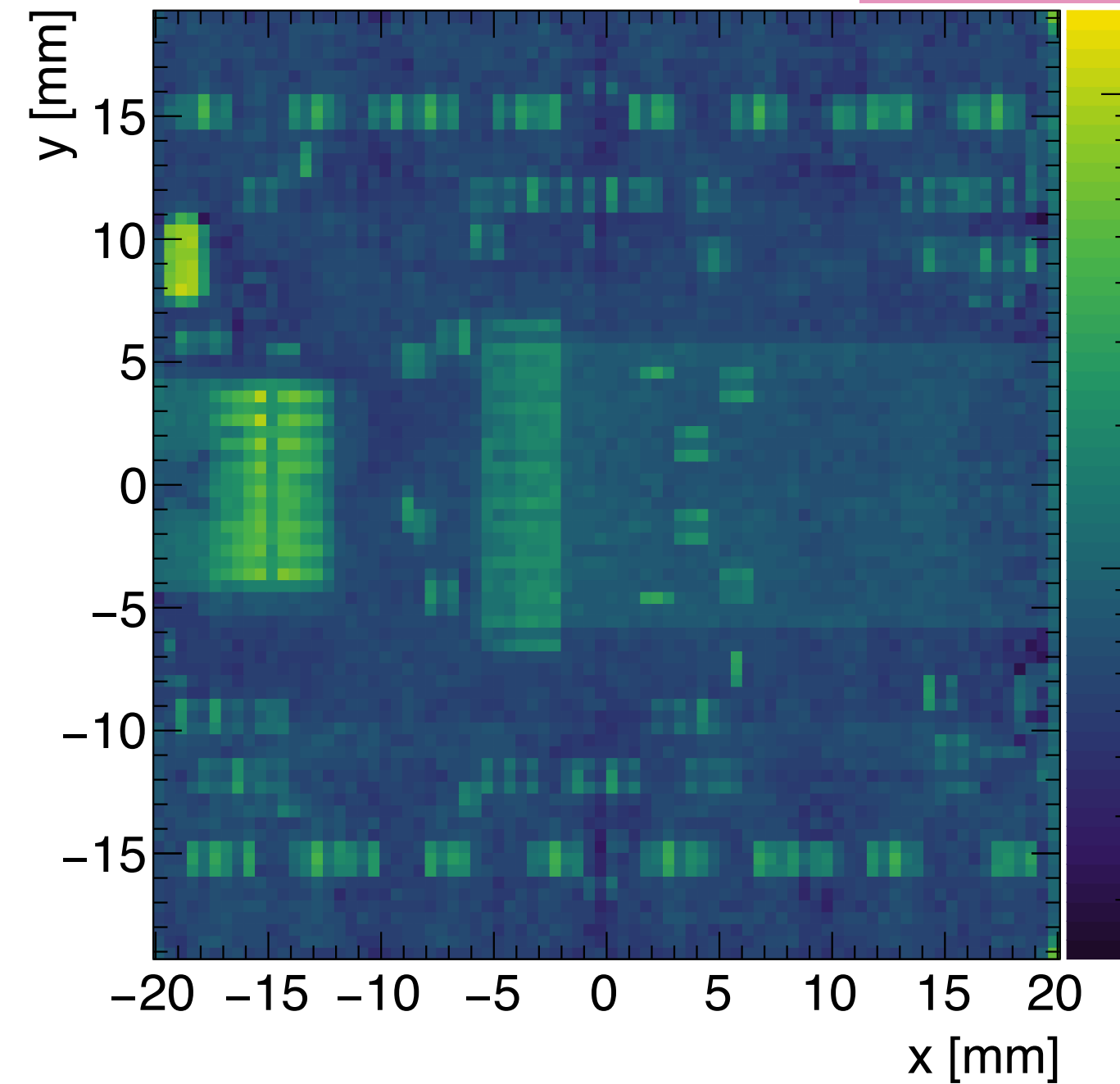

Estimate:

ATLAS ITk-Pixel Preliminary

Material budget estimate
 $\langle x/X_0 \rangle [\%] = 0.87$

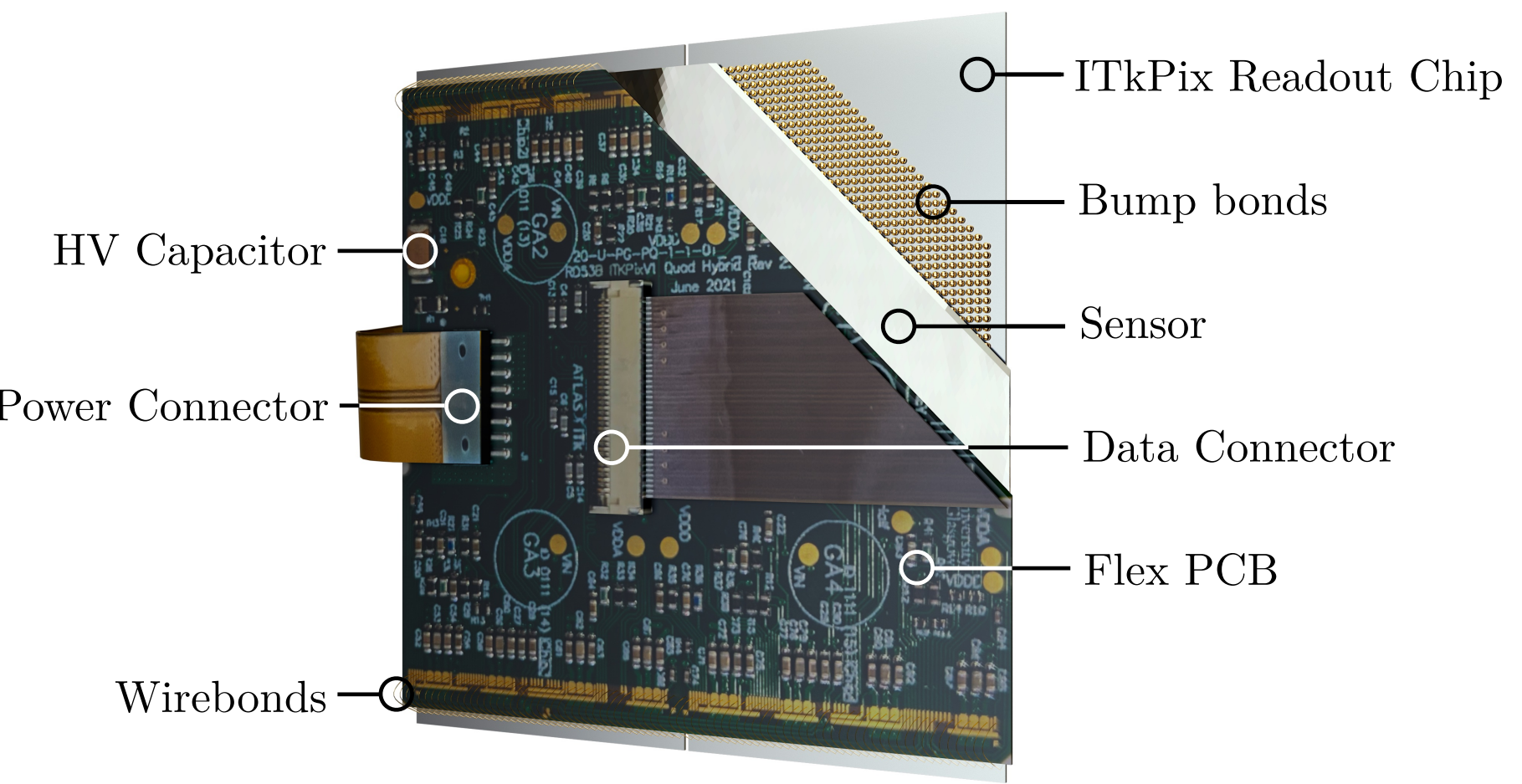
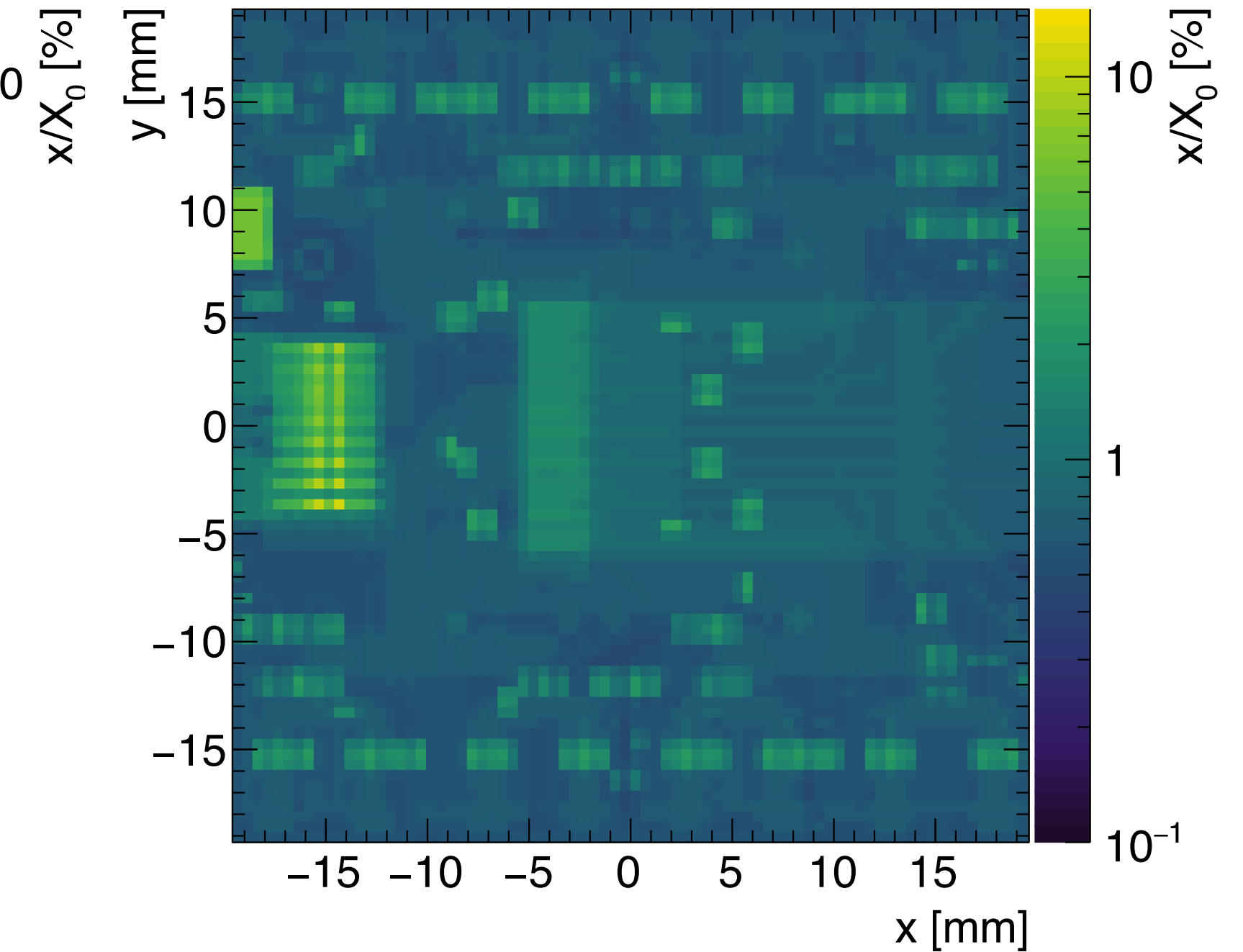

- Dominant uncertainty: **beam momentum band**
 (optimized to 5%, otherwise too low rate → limiting factor)



Scaling things up at the PSI

with S. Koch, R. Li, N. Dimova, A. McDougall, A. Ruggiero, B. Tuncay (Oxford)

- ▶ Partnered up with CMS and Mu3e for a follow-up measurement at the PiM1 beam line of the Paul-Scherrer-Institute, Switzerland

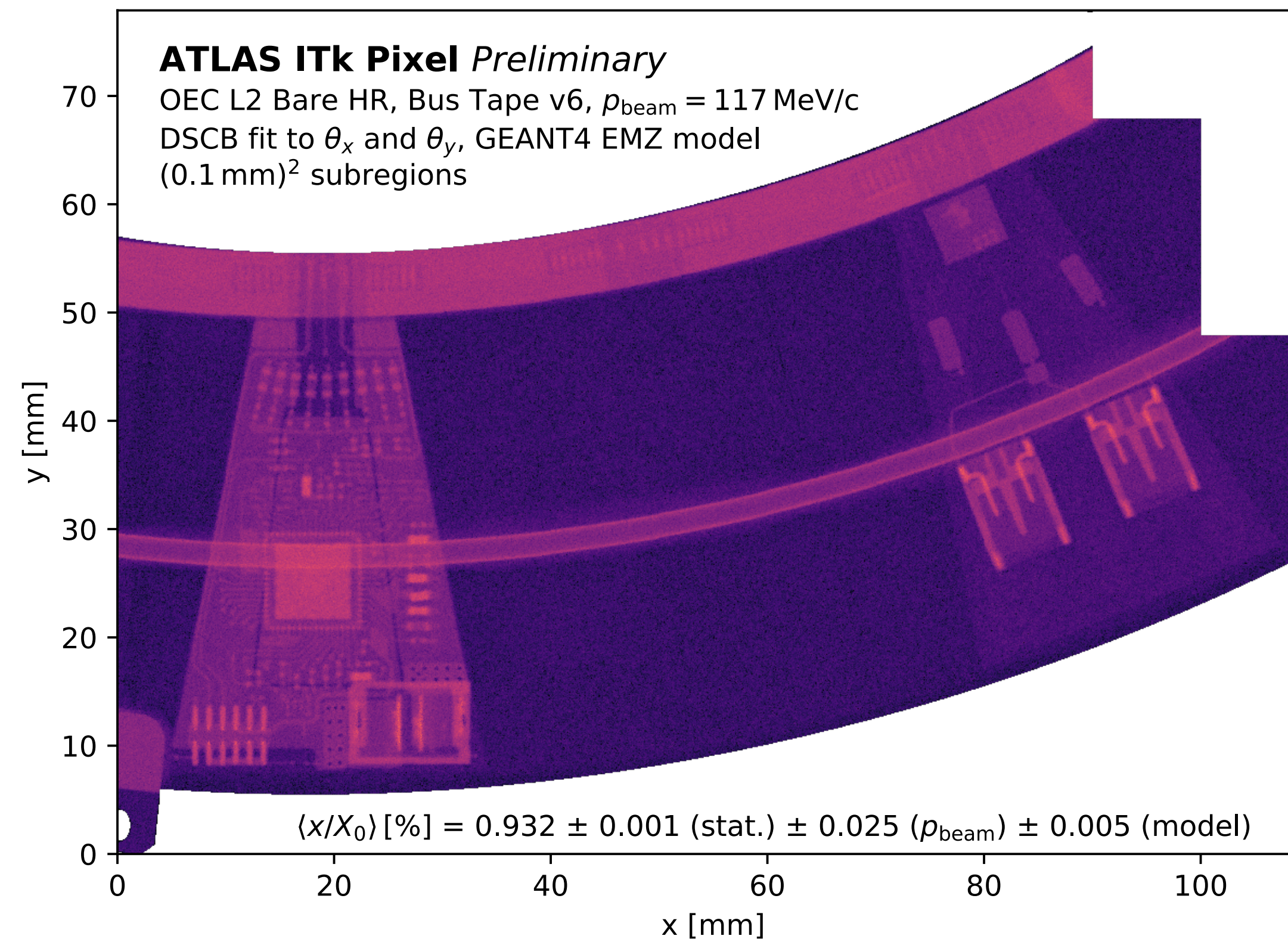
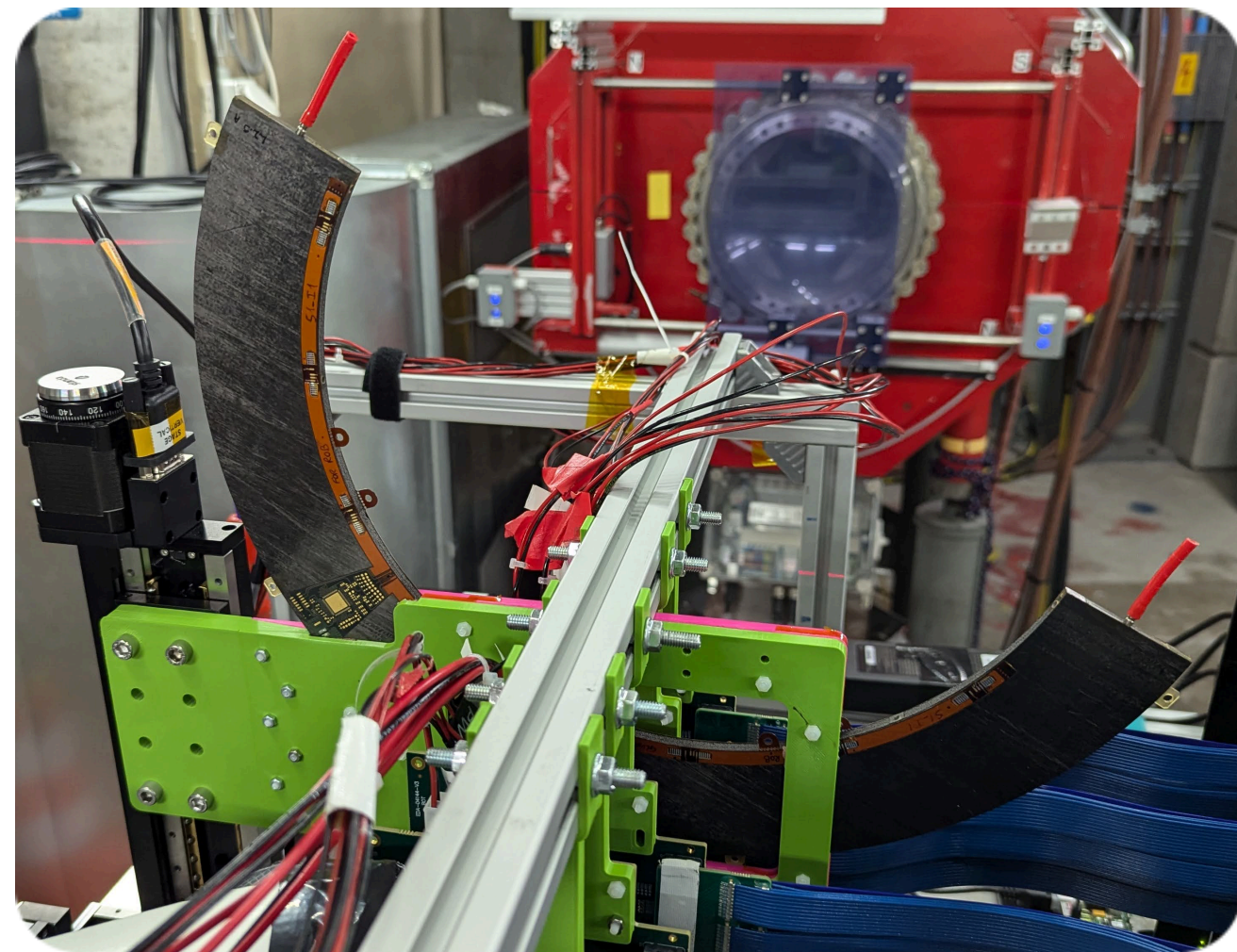
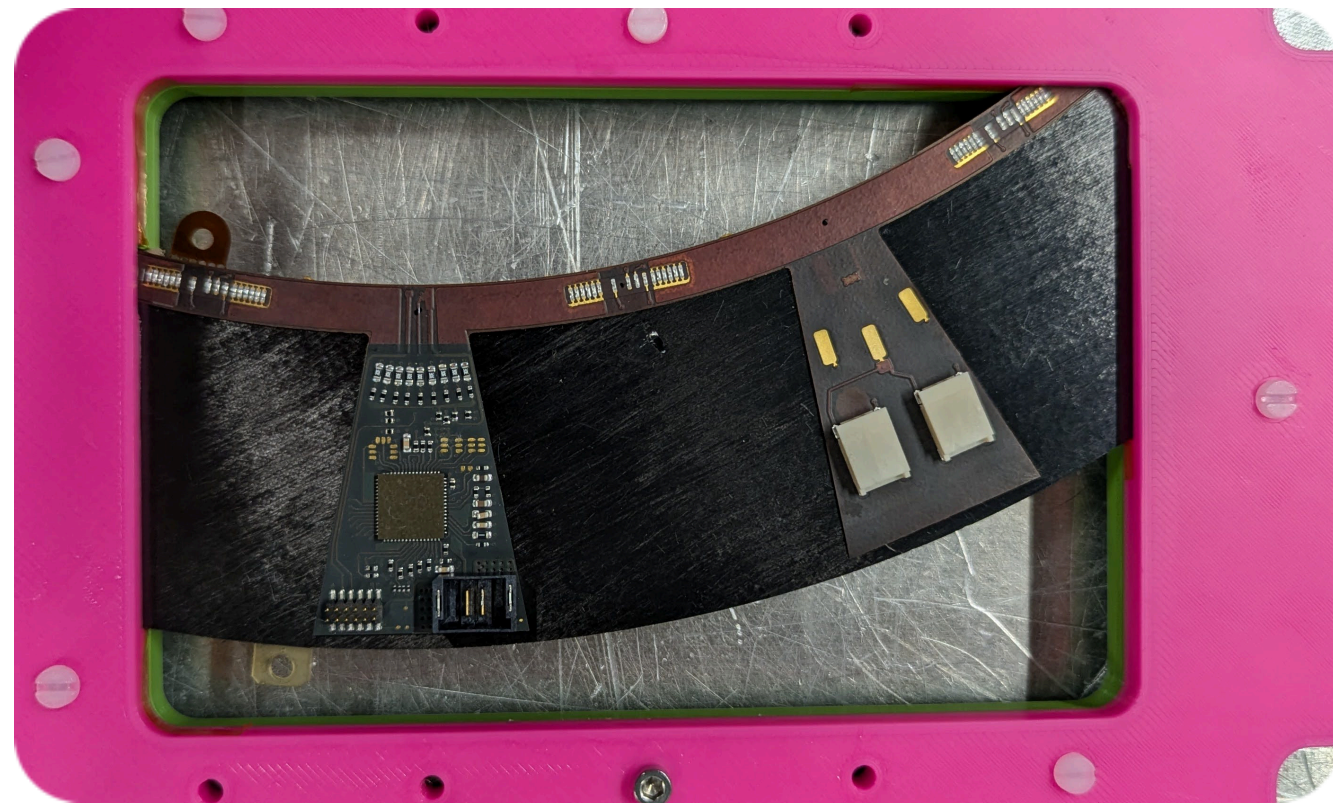

[Public plots]

Successfully measured over 500 cm^2 of detector components

Let's imagine we built the detector, know its material content very precisely ...

... what physics can we do with it?

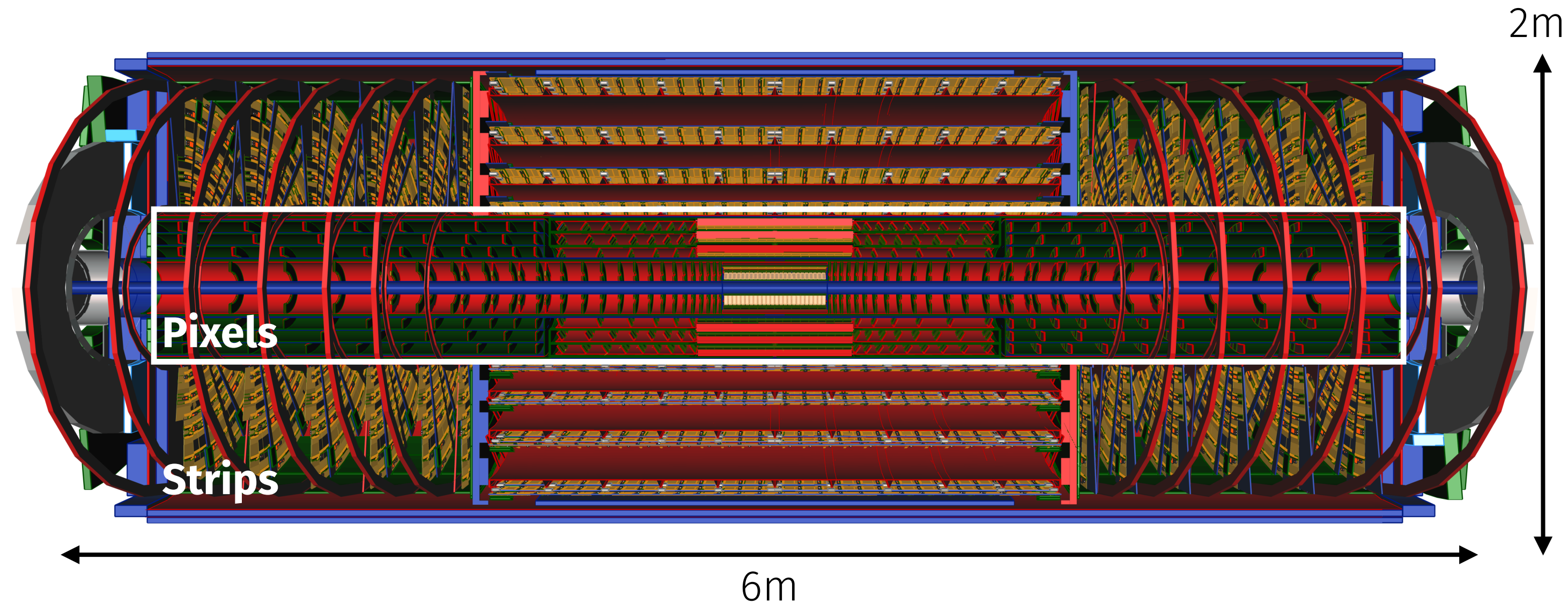

The physics potential of the HL-LHC: HH searches

- **Observation of HH production** (if SM-like) seems possible with the HL-LHC data set

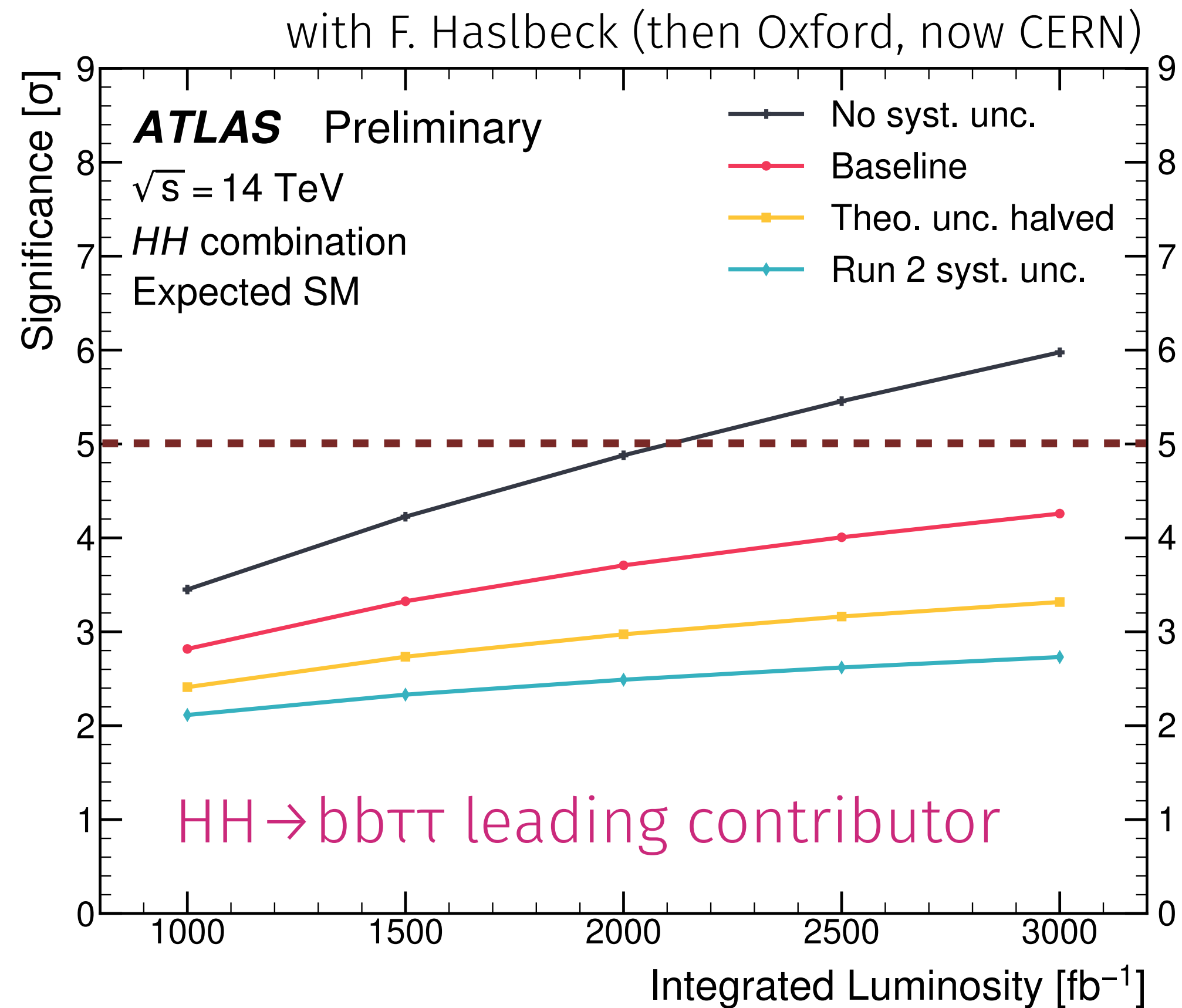

The physics potential of the HL-LHC: HH searches

- **Observation of HH production** (if SM-like) seems possible with the HL-LHC data set

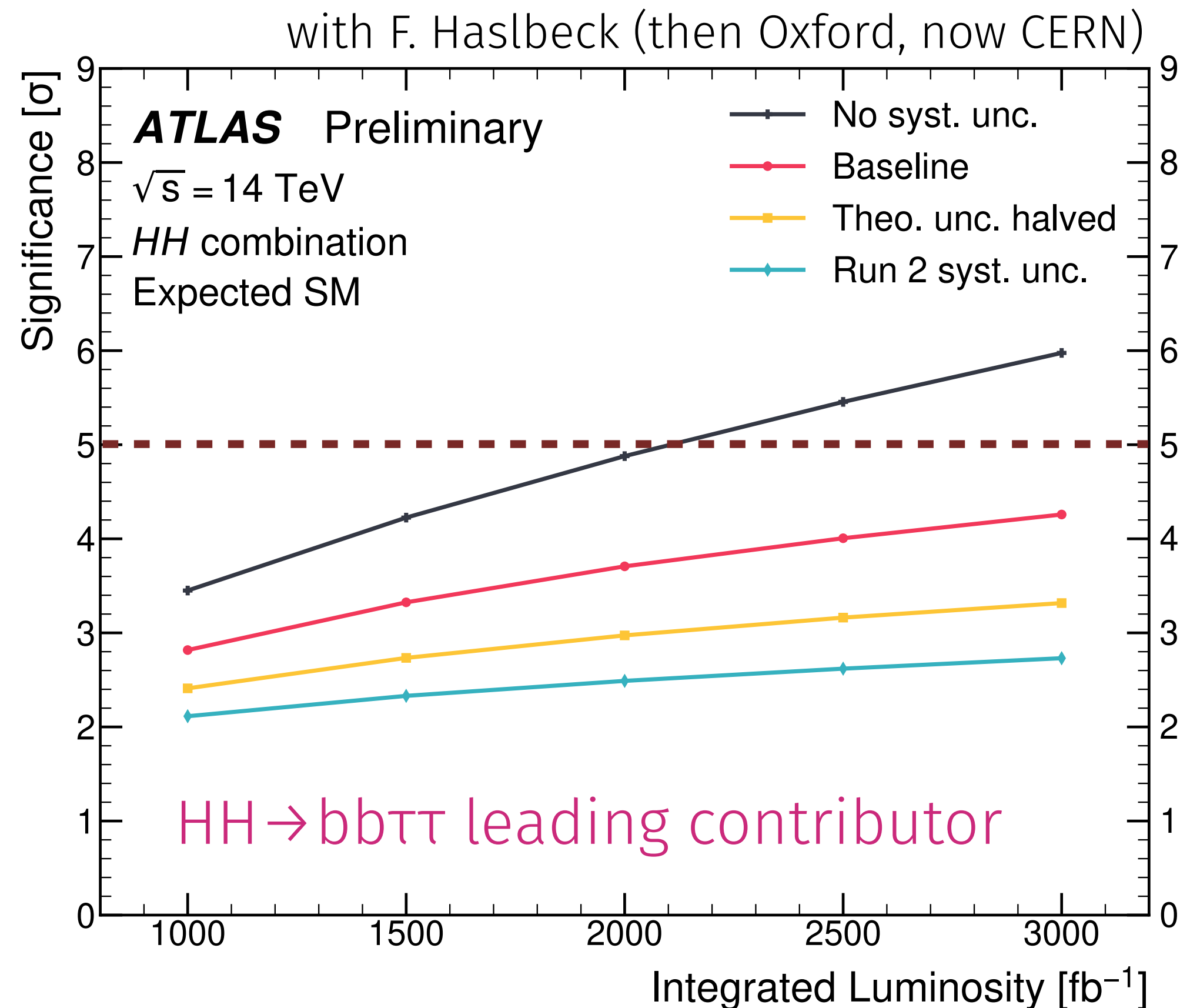

Caution with extrapolations!

[ATL-PHYS-PUB-2015-046]

Higgs Pair Production in the $H(\rightarrow \tau\tau)H(\rightarrow b\bar{b})$ channel at the High-Luminosity LHC

performed under different assumptions for the Higgs trilinear self-coupling values. Assuming SM background and SM signal, we expect to set an upper limit of the cross section for the di-Higgs production of $4.3 \times \sigma(HH \rightarrow b\bar{b}\tau^+\tau^-)$ at 95% Confidence Level. Using an

2015 extrapolation for the end of HL-LHC
 We are already doing better than this with Run 2 alone
 [5% of the dataset]

The physics potential of the HL-LHC: HH searches

- **Observation of HH production** (if SM-like) seems possible with the HL-LHC data set

with F. Haslbeck (then Oxford, now CERN)

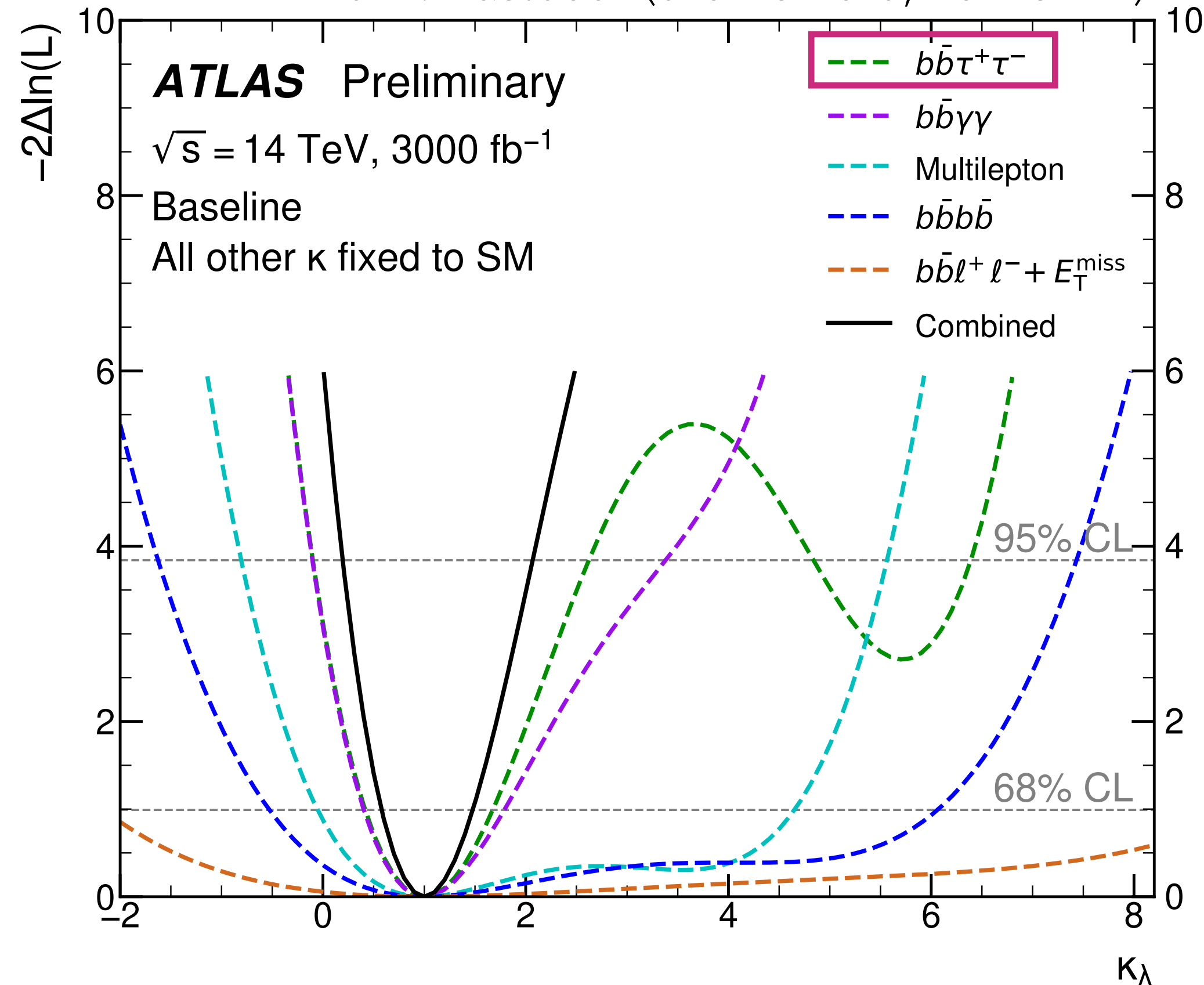

Caution with extrapolations!

[ATL-PHYS-PUB-2015-046]

Higgs Pair Production in the $H(\rightarrow \tau\tau)H(\rightarrow b\bar{b})$ channel at the High-Luminosity LHC

performed under different assumptions for the Higgs trilinear self-coupling values. Assuming SM background and SM signal, we expect to set an upper limit of the cross section for the di-Higgs production of $4.3 \times \sigma(HH \rightarrow b\bar{b}\tau^+\tau^-)$ at 95% Confidence Level. Using an

2015 extrapolation for the end of HL-LHC
 We are already doing better than this with Run 2 alone
 [5% of the dataset]

- This would translate into a **O(50%) precision** on the **Higgs boson self-coupling**

So, does the Higgs boson wear a Mexican-hat?

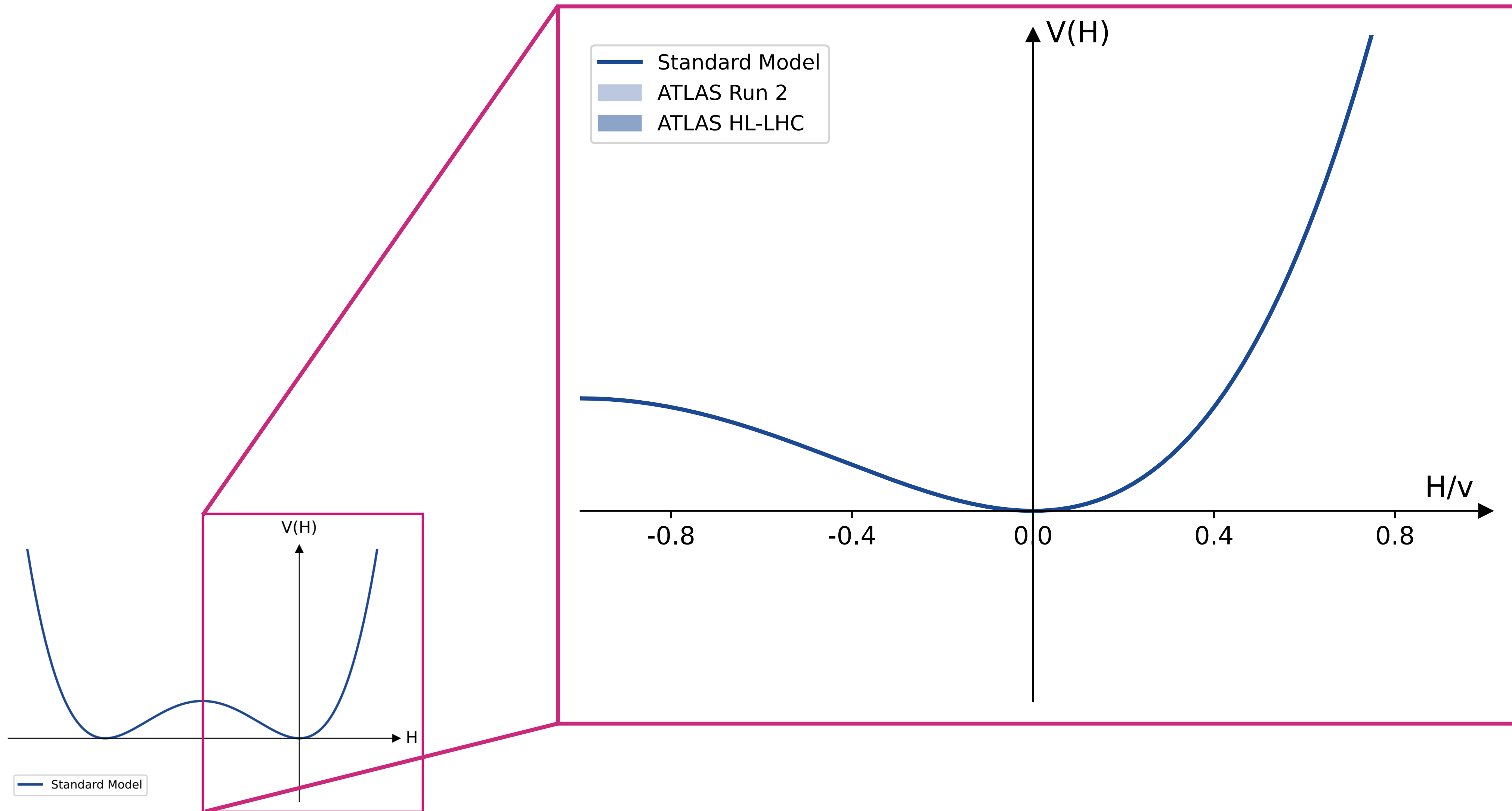

So, does the Higgs boson wear a Mexican-hat?

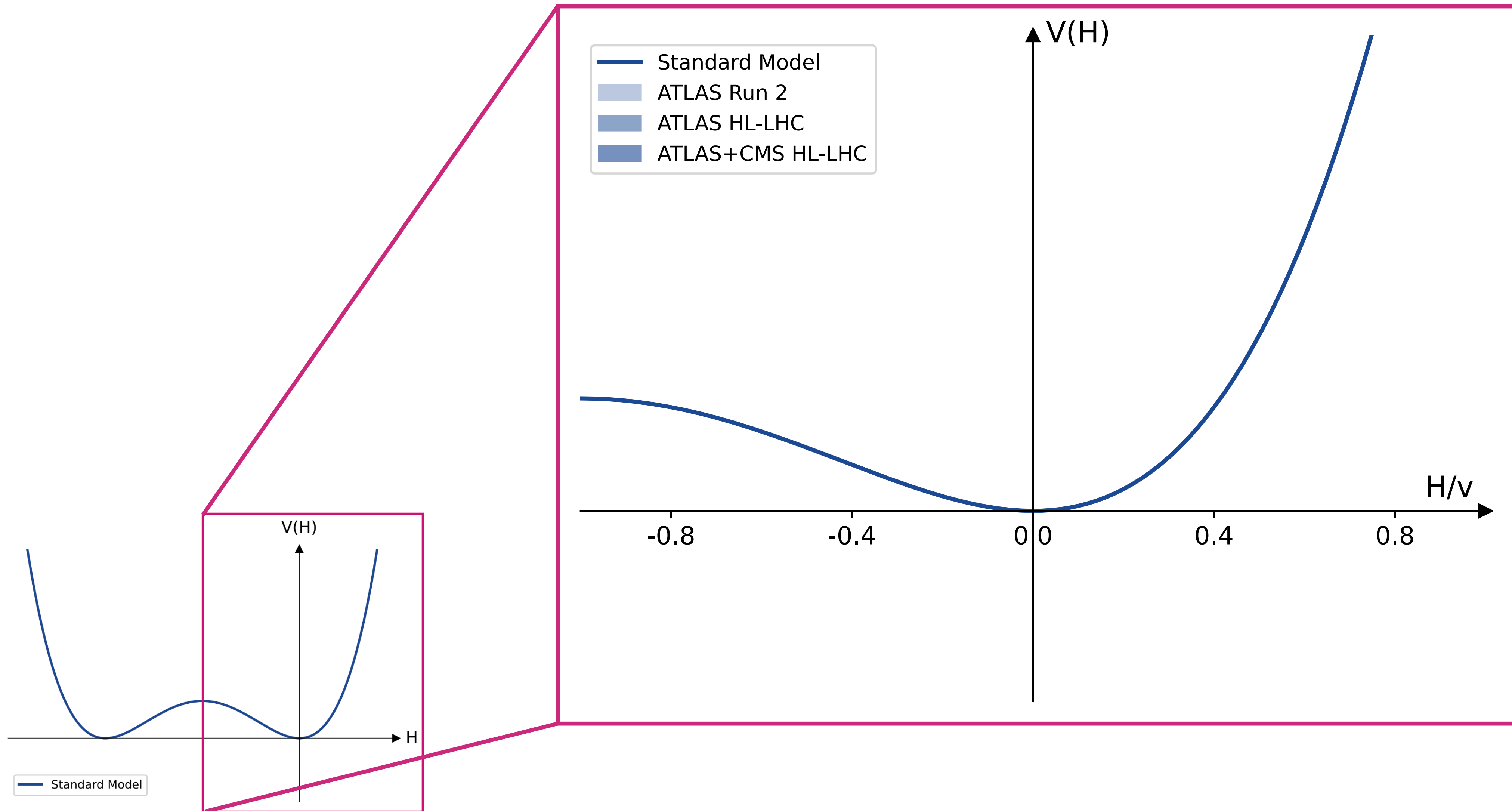

So, does the Higgs boson wear a Mexican-hat?

- ▶ Studying the shape of the Higgs potential via HH searches is crucial
- ▶ Observation of Higgs boson pair production seems in reach at the HL-LHC, but in order to record and make use of the data ATLAS needs a new tracker
- ▶ Ultimate precision on the Higgs potential shape can be reached at future machines

Exciting times ahead!

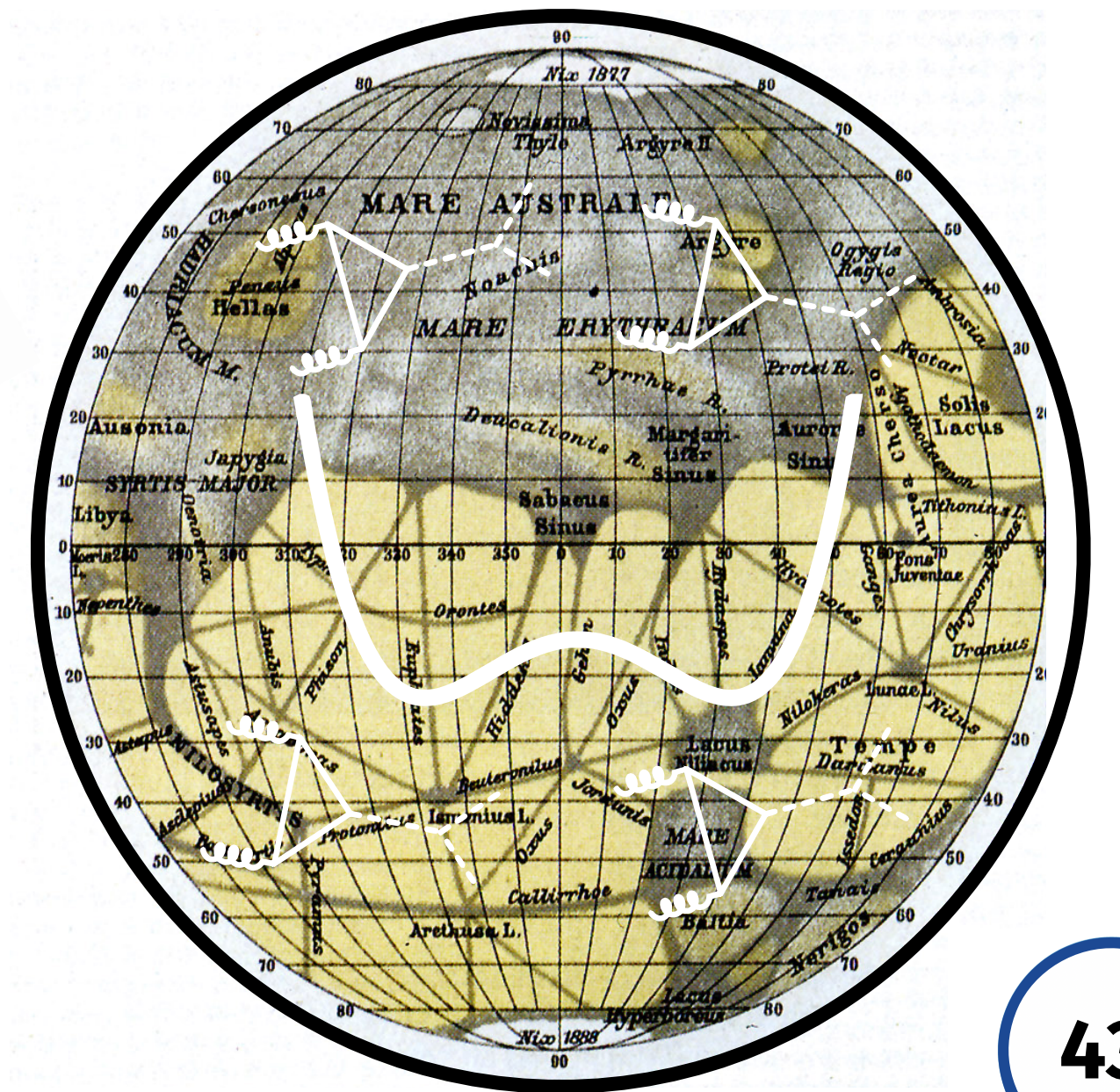
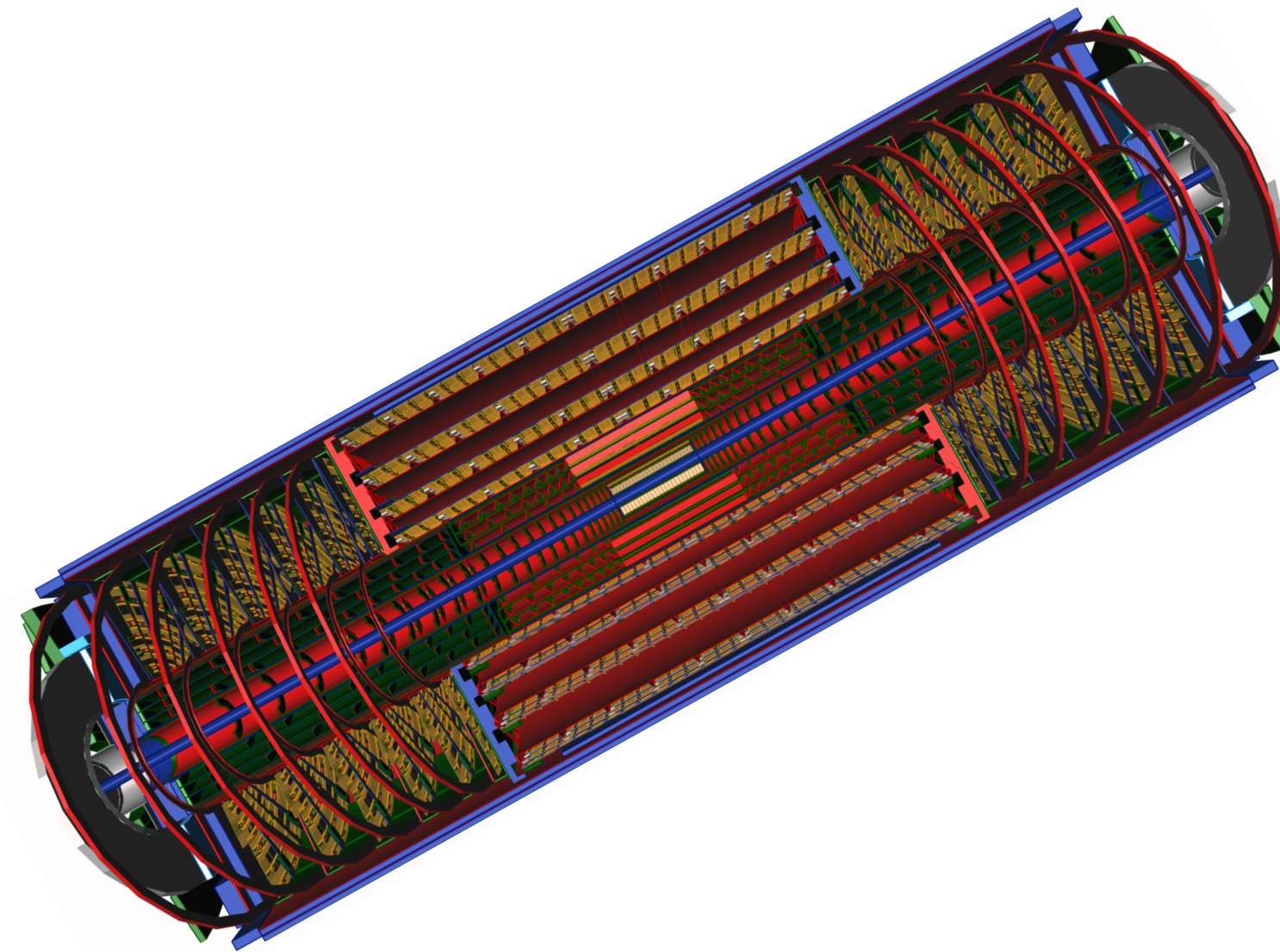
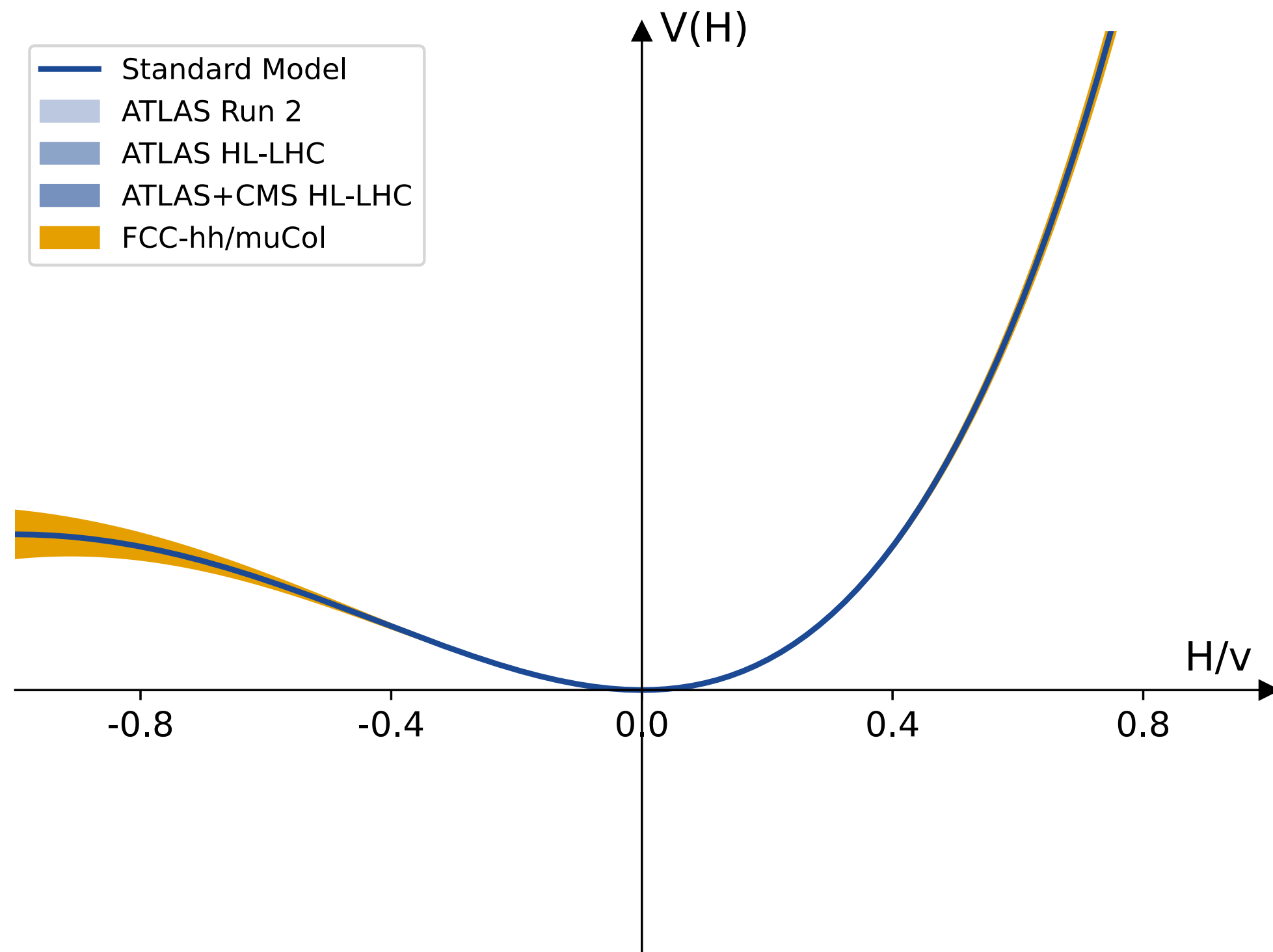

The image features a dark blue background filled with a dense field of small, bright blue particles. These particles are arranged in a way that suggests a circular or spherical shape, with a brighter, more concentrated area on the right side. The overall effect is that of a glowing, ethereal sphere or a nebula. In the center of this particle field, the word "Backup" is written in a clean, white, sans-serif font. The text is centered horizontally and vertically, standing out prominently against the complex, textured background.

Backup

Bonus: One, two, three, Higgs

$$V(H) = \frac{1}{2}m_H^2 H^2 + \lambda_3 \text{vev } H^3 + \frac{1}{4}\lambda_4 H^4$$

- ▶ In the SM (and dim-6 SMEFT) the cubic and quartic Higgs self coupling are linked
- ▶ This does not need to be the case (e.g. in HEFT) → searches for HHH can complement the picture

pp → HH:

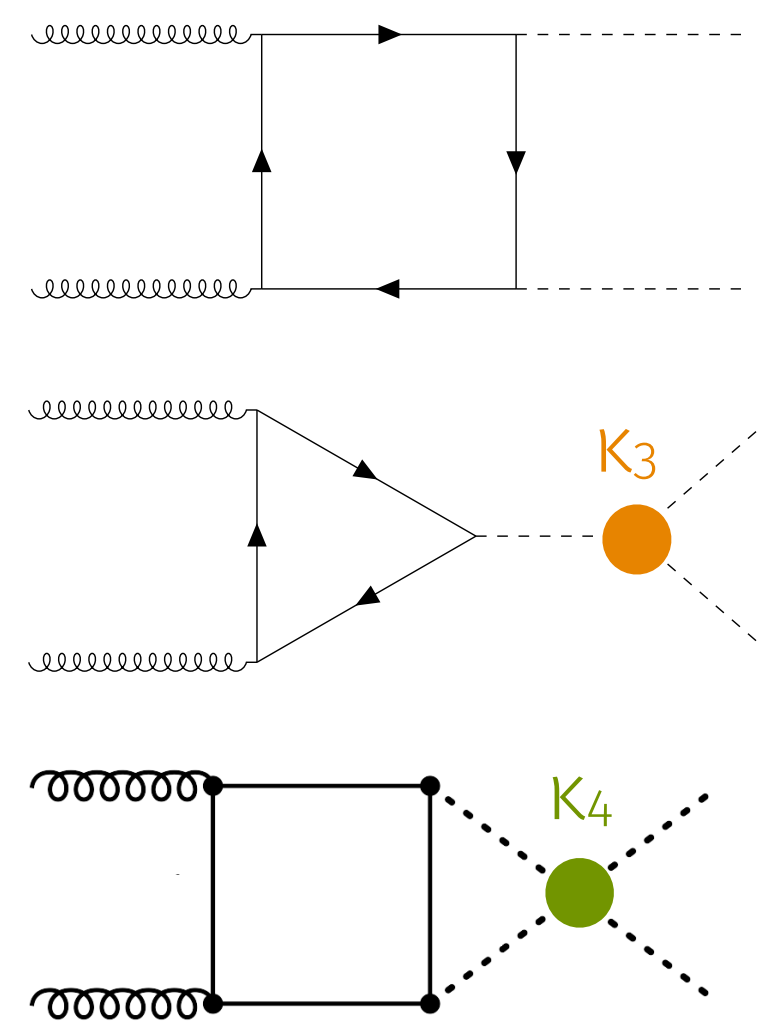

[arXiv:2402.03463]

Brian Moser

pp → HHH:

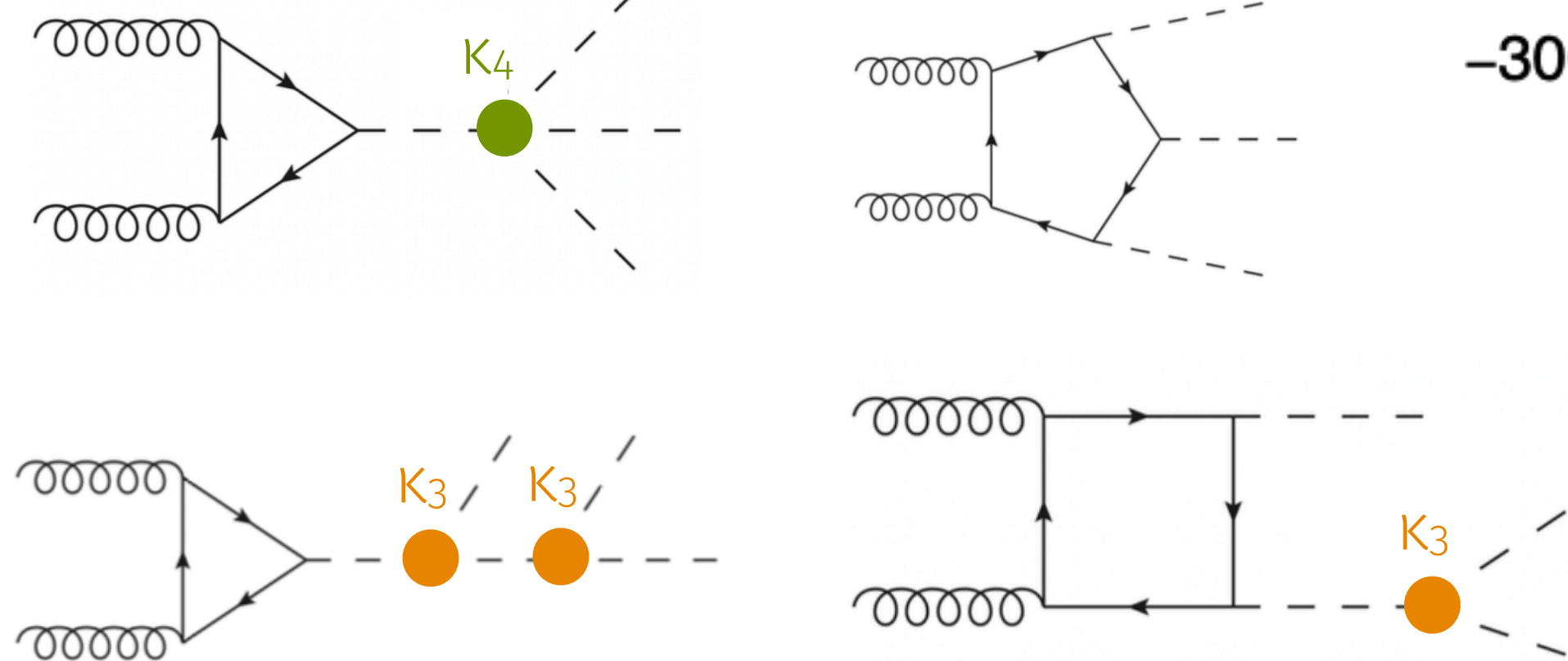

First exp. results become available, e.g. ATLAS search for HHH → 6b [Phys. Rev. D 111 (2025) 032006]

Does the Higgs boson wear a Mexican-hat?

Nice complementarity between HH and HHH searches

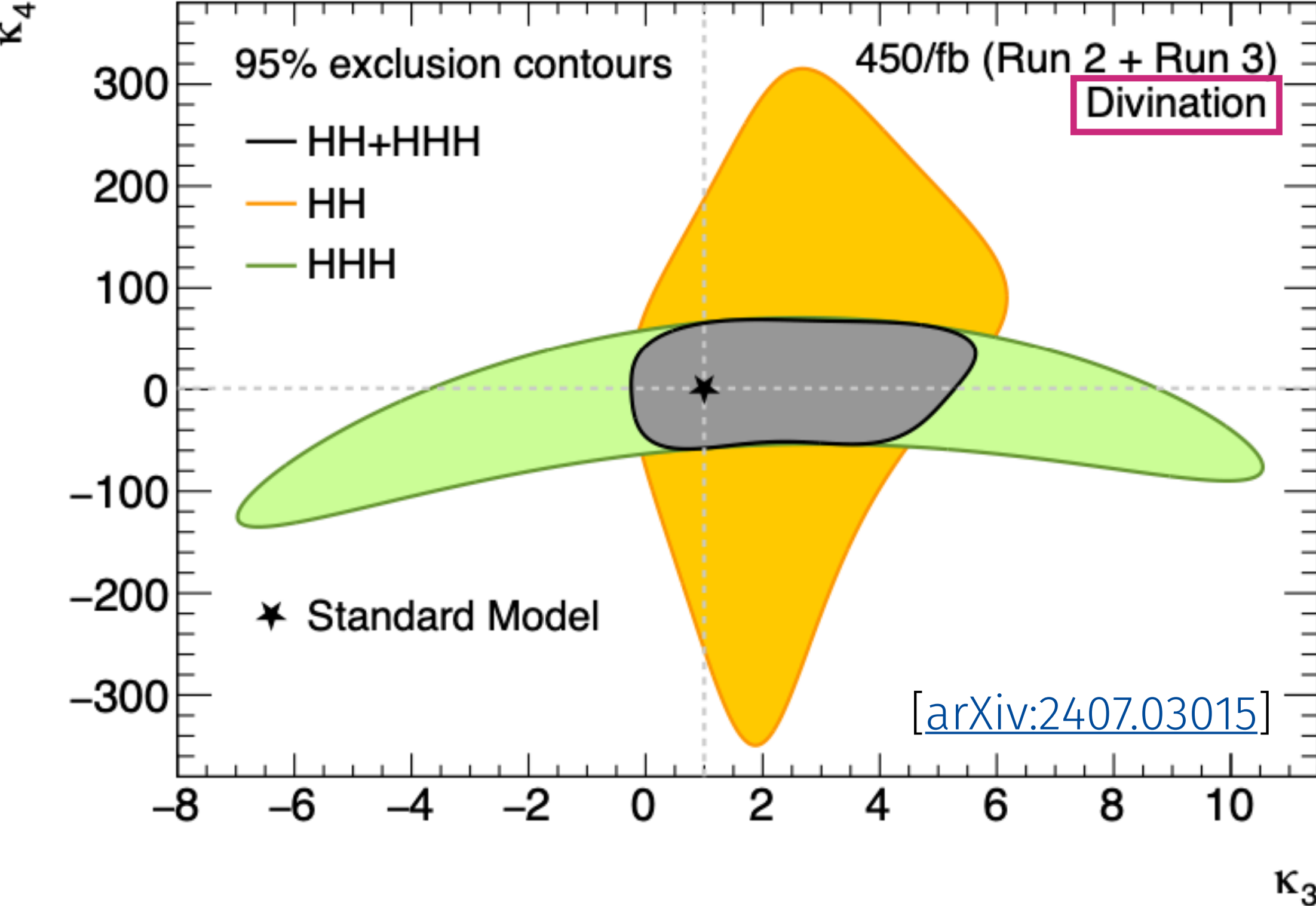

Run 2 expected yields:

- pp → HH: ~ 4000 events
- pp → HHH: ~ 13 events



14/05/2026

Keep your material budget low!

- Multiple Scattering described by a Gaussian core with $\sin(\theta)^{-4}$ Rutherford tails
 - can be described by a **double sided crystal ball** function

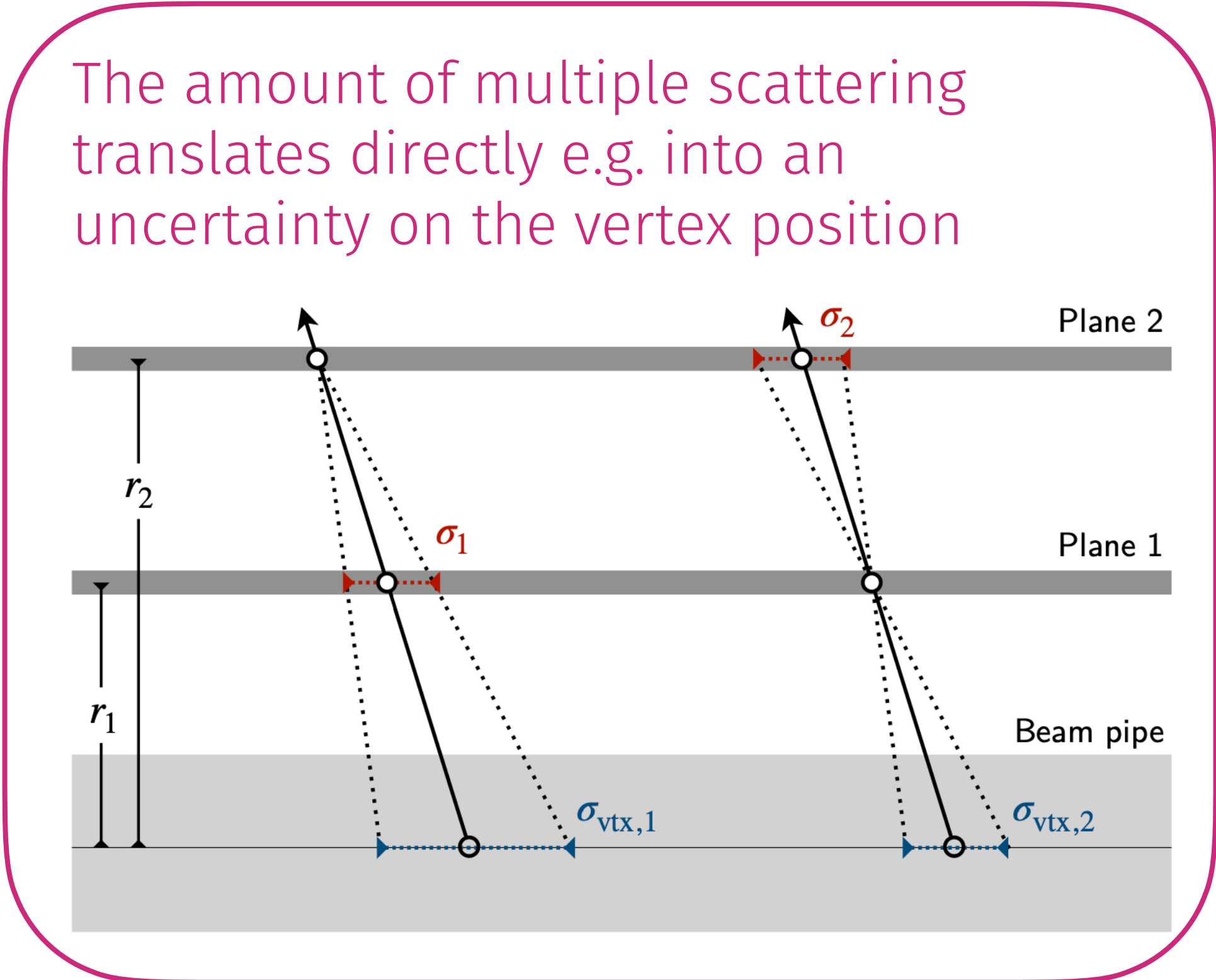
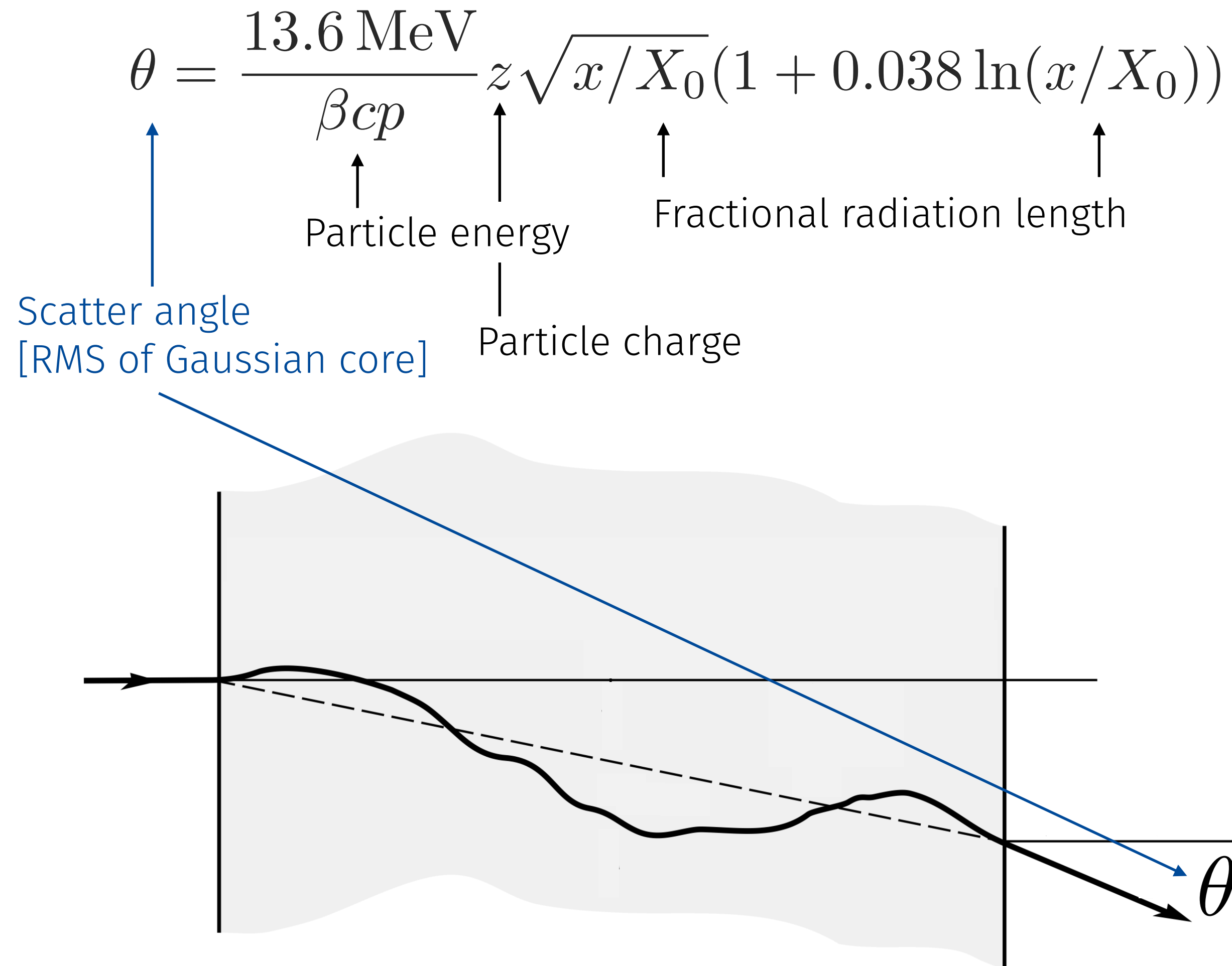

For particles with known energy we can measure the scatter angle to infer the fractional radiation length

Higgs physics at the Future Circular Collider (ee)

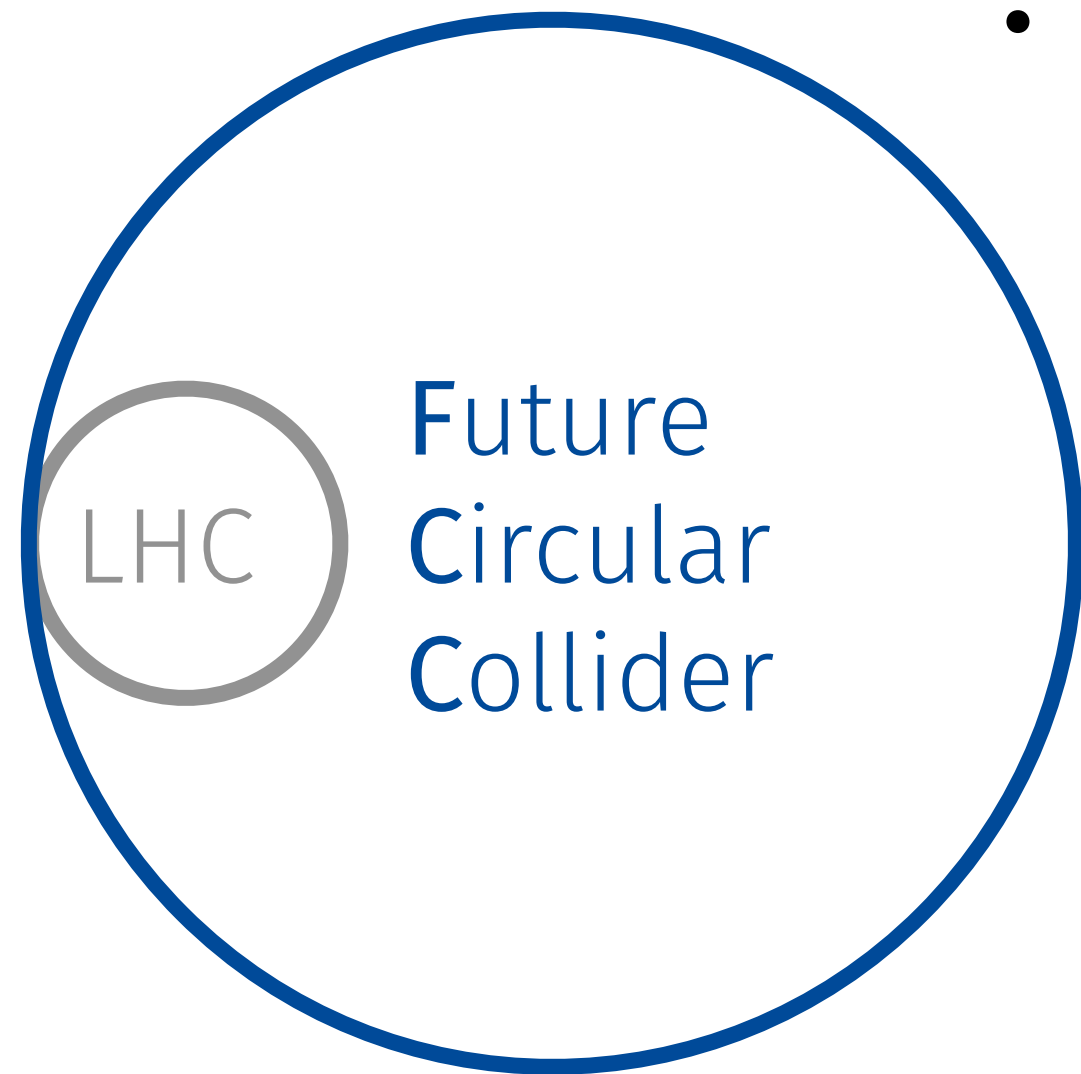

- 1st stage: e^+e^- collider (FCC-ee)
 - 91 km length
 - Multiple \sqrt{s} up to 365 GeV \rightarrow no HH 😞
- Followed up by a pp machine \rightarrow HH 😊

Main Higgs boson production mode at $\sqrt{s} = 240$ GeV

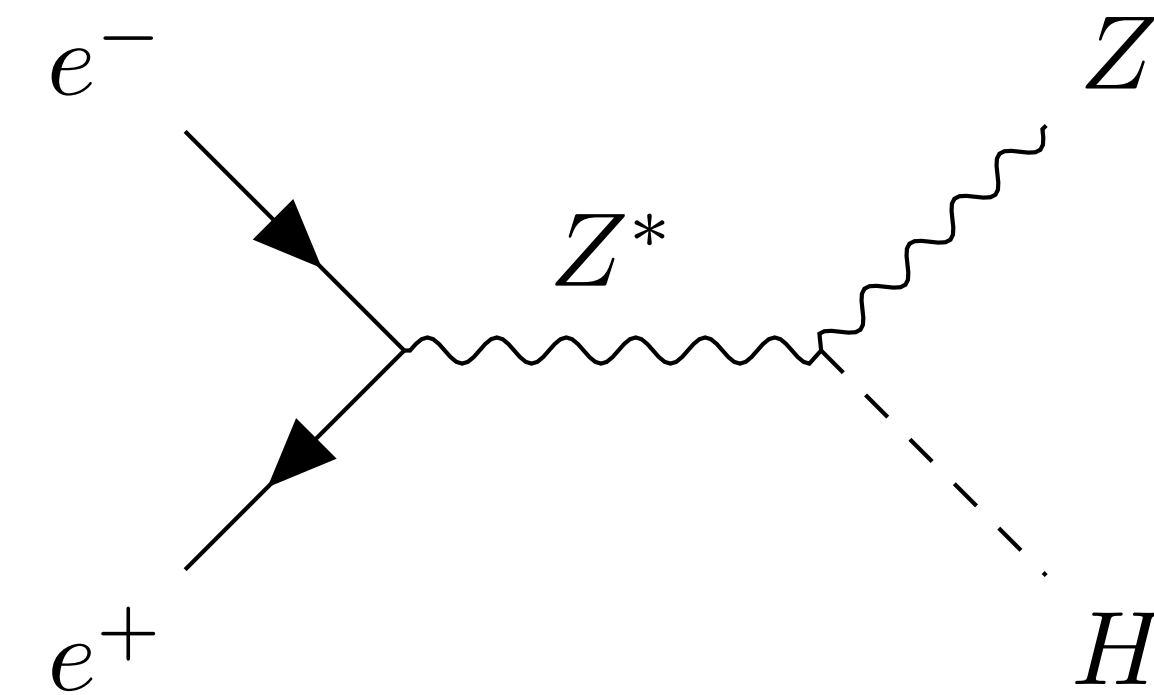

Planned FCC-ee programme:

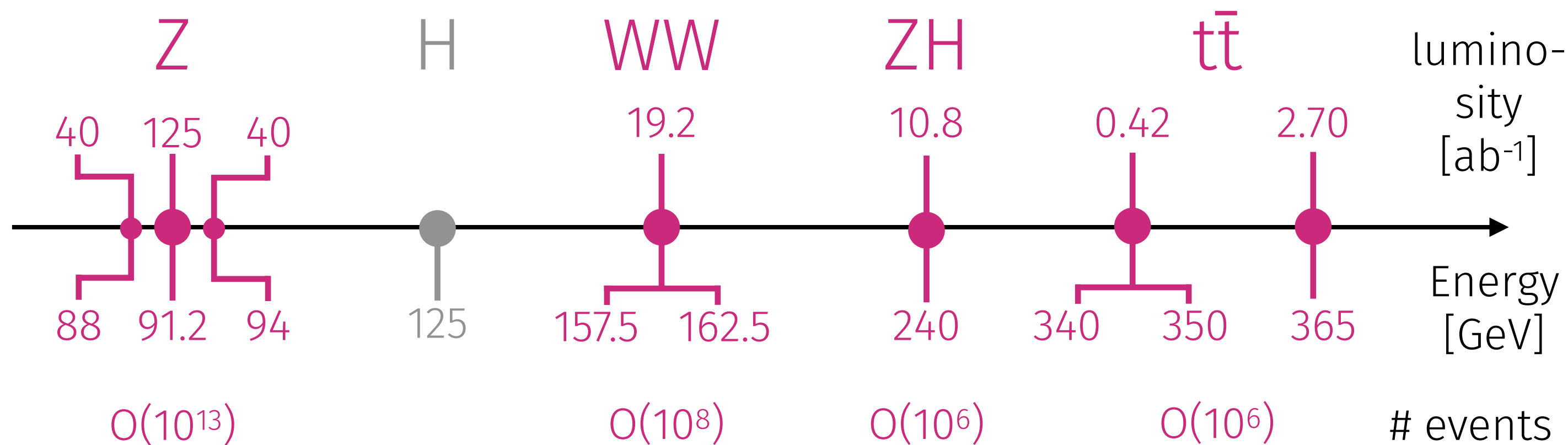

Unique feature of e^+e^- : recoil mass

$$(P_{e^+}^\mu + P_{e^-}^\mu) = (P_H^\mu + P_Z^\mu)$$

$$m_H^2 = s + M_Z^2 - 2\sqrt{s} E_Z$$

Example: $H \rightarrow bb$ at the LHC vs. FCC-ee

Resolution: ~ 10 GeV

e^+e^- : recoil mass

Resolution: $O(0.5$ GeV)

V. Halfman (Freiburg)

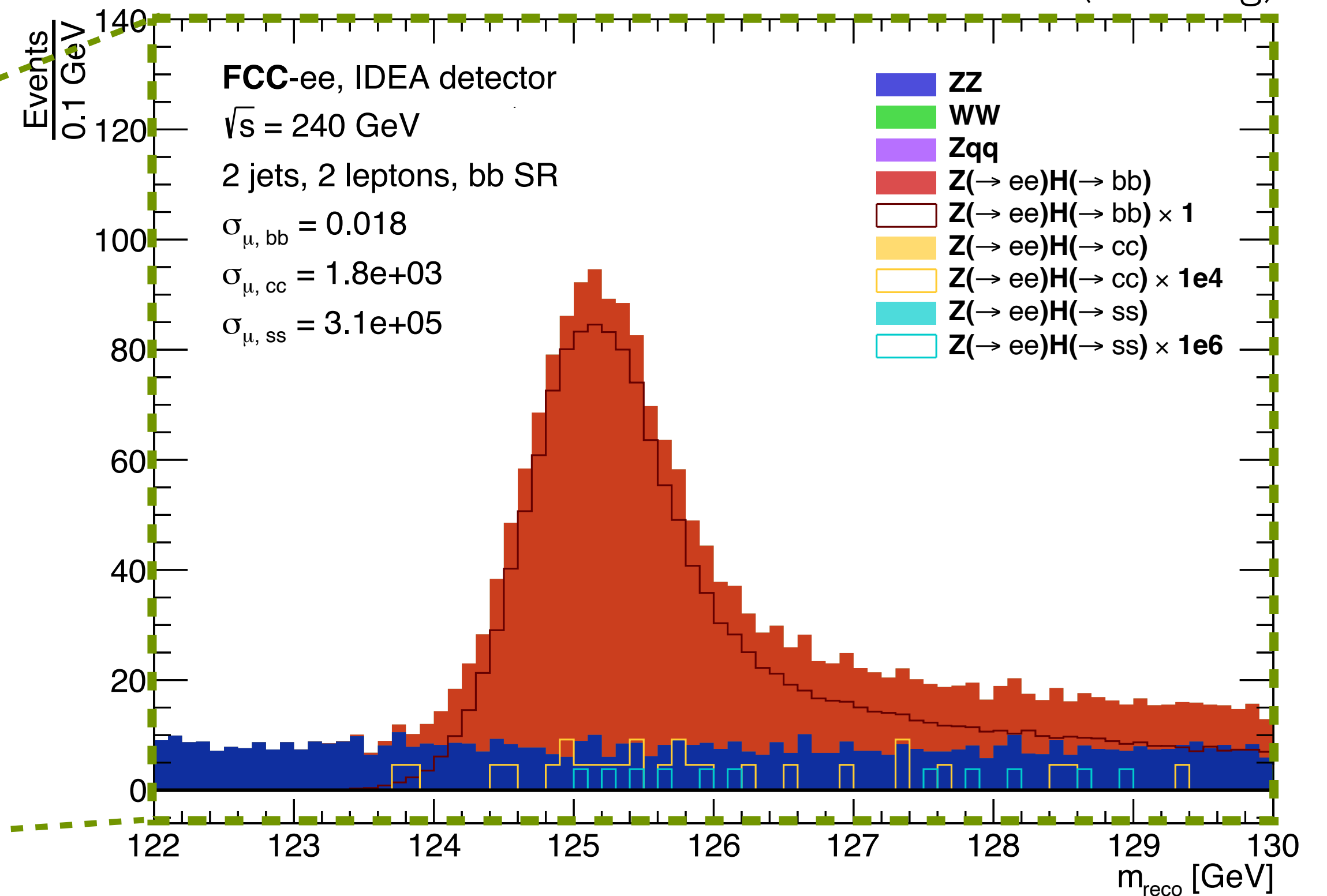
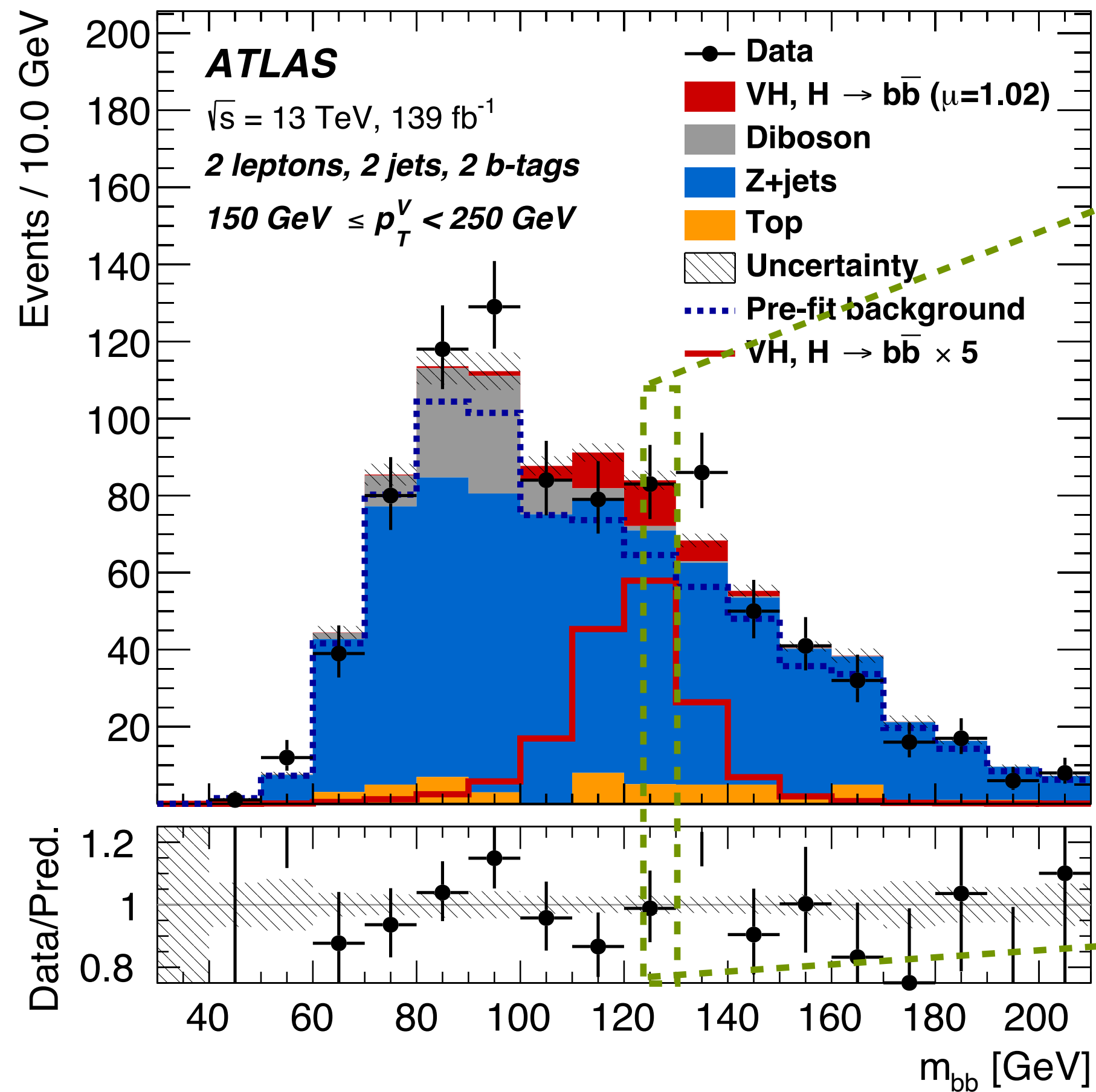

\rightarrow %-level, model independent determination of b-quark Yukawa coupling will be possible