

Interactions of Particles with Matter – Part 2

Karol Krizka

k.krizka@bham.ac.uk

May 19, 2023



UNIVERSITY OF
BIRMINGHAM

UK Adv Instr 2023

Two Lectures

Lecture 1: Mechanics of Particle Interactions with Matter

- Define “particle” interactions with “matter”
- Ionizing Radiation
- Non-Ionizing Radiation

Lecture 2: Detecting Particle Interactions with Matter

- Efficiencies and energy resolutions for individual sensors
- Brief overview of silicon sensor technologies
- Gaseous detectors for tracking
- Signal formation in a single diode

Further Reading

This is a survey lecture to summarize many mechanisms.

The following are references for a more in-depth understanding.

Particle Data Group's Review

1 *34. Passage of Particles Through Matter*

34. Passage of Particles Through Matter

Revised August 2021 by D.E. Groom (LBNL) and S.R. Klein (NSD LBNL; UC Berkeley).

Applications of silicon strip and pixel-based particle tracking detectors

[Philip Allport](#) ✉

Nature Reviews Physics 1, 567–576 (2019) | [Cite this article](#)

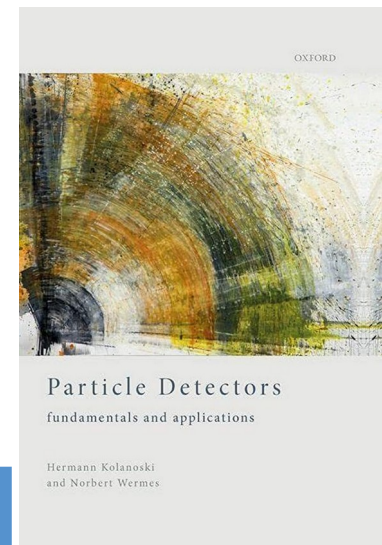
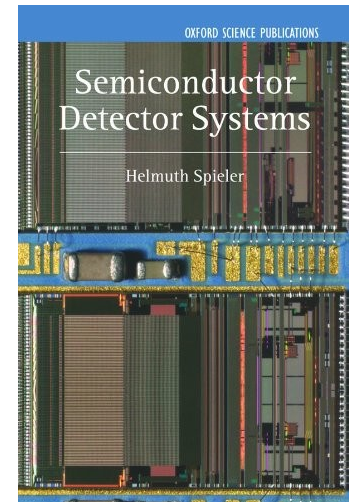
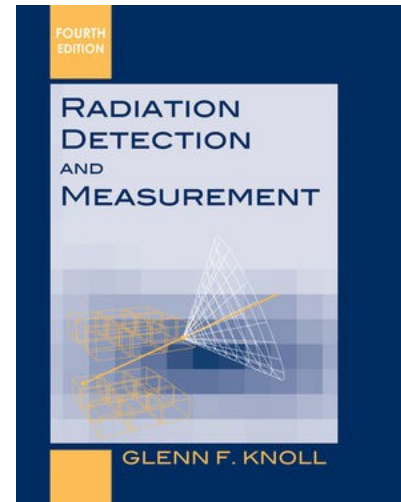
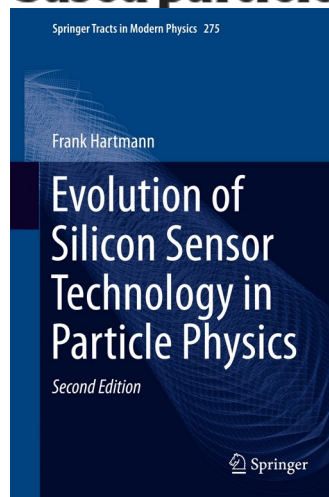

Material based on Phil Allport's.

Example Types of Particles

How about other particles
(muons, pions, taus)?

- **Ions**

- protons, alpha particles, fission fragments
- straight tracks

- **Electrons (β particles)**

- Negative and positive
- Scattered tracks

- **Neutrons**

- Interact only with nucleons

- **Photons**

- gamma-rays and X-rays
- Interact with atoms/electrons

Charged Particles

- Ionize atoms along the way
- Can be followed via a “track”

Neutral Particles

- Identified via secondary tracks

ATLAS Inner Most Pixel Layer

Study of the material of the ATLAS inner detector for Run 2 of the LHC

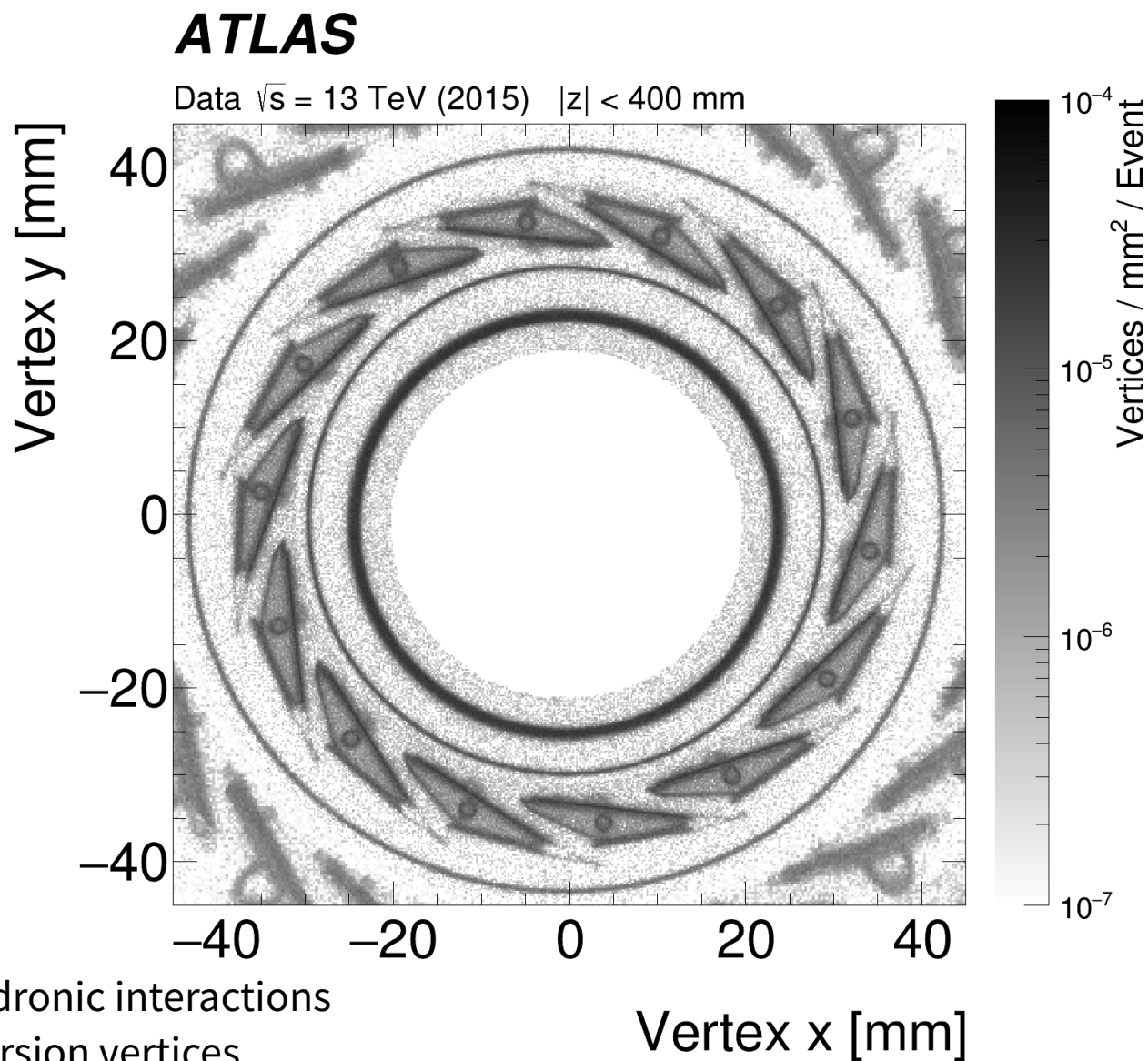

Reconstructed hadronic interactions
and photon conversion vertices.

Sensor Efficiency Definitions

Intrinsic efficiency measures efficiency of **detector element**.

$$\epsilon_{\text{int}} = \frac{\text{number of pulses detected}}{\text{number of incident particles}}$$

$$\epsilon_{\text{int}}(\text{charged}) \approx 1 \quad \epsilon_{\text{int}}(\text{neutral}) \ll 1$$

Absolute efficiency measures efficiency of **entire detector**.

$$\epsilon_{\text{abs}} = \frac{\text{number of pulses detected}}{\text{number of emitted particles}}$$

Point source subtended by Ω
solid angle of detector.

They are related (for example) coverage of detector:

$$\epsilon_{\text{abs}} = \frac{\Omega}{4\pi} \epsilon_{\text{int}}$$

Intrinsic Sensor Resolution: Statistics

Energy deposition is a random process.

1) A traversing particle deposits (exactly) E energy.

2) Number of signal carrier created is $N = E/w$.

- w is the energy to create a single signal carrier

• Creating a carrier is a random and independent event

- Poisson statistics!

$$\langle N \rangle = N$$
$$\sigma_N = \sqrt{N}$$

Intrinsic Sensor Resolution: Fano Factor

Signal carrier are *not independent events*.

- (Fixed) input of energy is *absorbed in different ways*.
- *Total energy absorbed* must equal (fixed) input energy.
- **Fano Factor (F)** is a correction to account for these variations.
 - Also a random process, usually with a very small variance.
 - $F \leq 1$, by definition.

$$\langle N \rangle = FN$$
$$\sigma_N = \sqrt{FN}$$

Example Fano Factor Values

Consider energy deposited as ionizing (E_{ion}) and lattice (E_{phonon}).

$$E = E_{\text{ion}} N_{\text{ion}} + E_{\text{pho}} N_{\text{pho}}$$

Correlated statistical **variations** in N_{ion} and N_{pho} , as **E is fixed**.

See chapter X in Speiler for derivation.

Example Theoretical Values

	Feno Factor
Si	0.115
Ge	0.13
GeAs	0.12
Diamond	0.08

Example Measured Values

	Feno Factor
Ar (gas)	$0.20 \pm 0.01/0.02$
Xe (gas)	0.13 ± 0.29
CZT	0.089 ± 0.05

Intrinsic Sensor Resolution: Poisson

For large $\langle N \rangle$, Poisson distribution \sim Gaussian distribution.

$$P(N) = \frac{1}{\sqrt{2\pi}\sigma} \exp\left(-\frac{(N - \langle N \rangle)^2}{2\sigma^2}\right)$$

Experimentally, we measure Full Width at Half Maximum (FWHM) of pulse heights, $H \propto N$.

$$\text{FWHM} = 2\sqrt{2 \ln 2} \sigma \approx 2.35\sigma$$

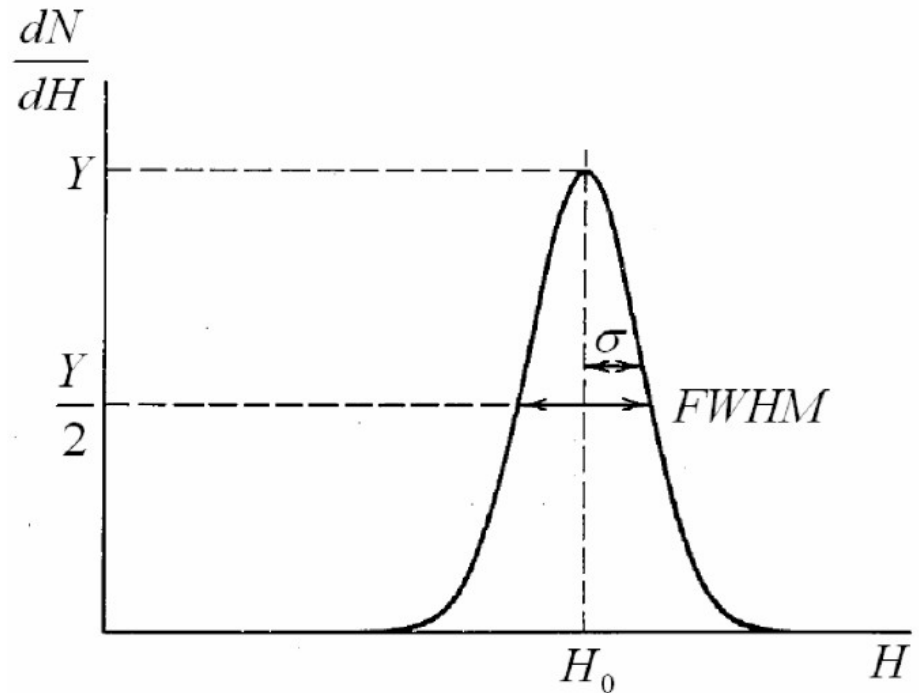

Intrinsic Sensor Resolution: Poisson

Energy resolution, ΔE , is defined as $FWHM/H_0$.

Distinguish two peaks when separated by FWHM.

Take k to be proportionality.

$$H = kN ; H_0 = k\langle N \rangle$$

Using prev. equations...

$$\Delta E = 2.35 \sqrt{\frac{Fw}{E}}$$

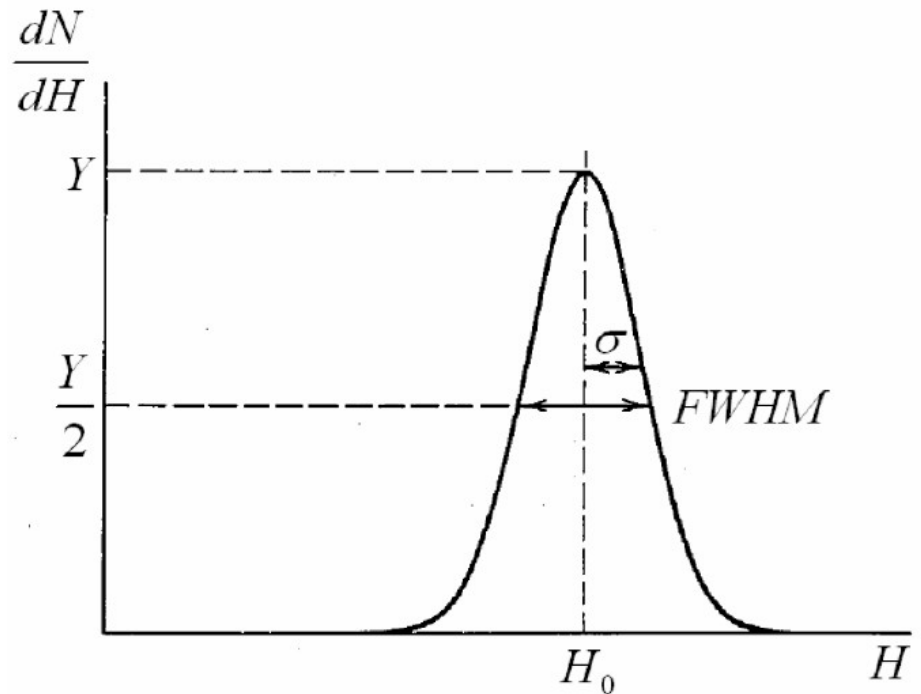

Intrinsic Sensor Resolution: Poisson

Charged particle trajectory reconstruction (*tracking*) requires **precise position information**. **Semiconductors are great** for this!

Example Technologies

- Strip detectors
- Silicon drift detectors
- Hybrid pixel detectors
- Monolithic pixel detectors
- Charged Coupled Devices
- 4D detectors (timing)
- 3D pixels

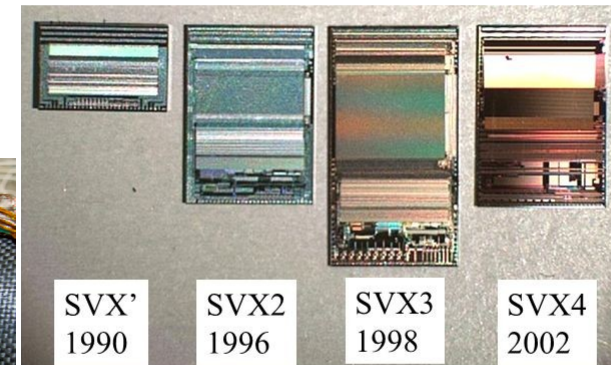
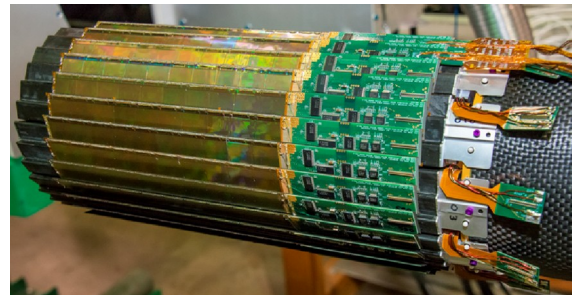
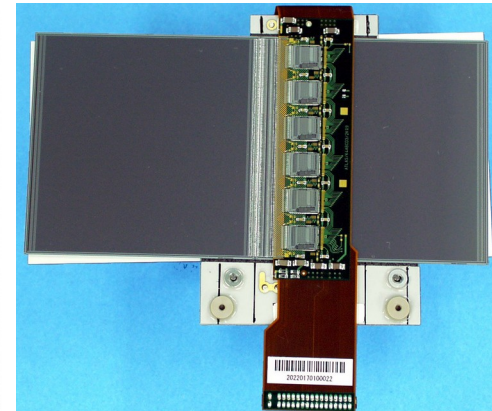
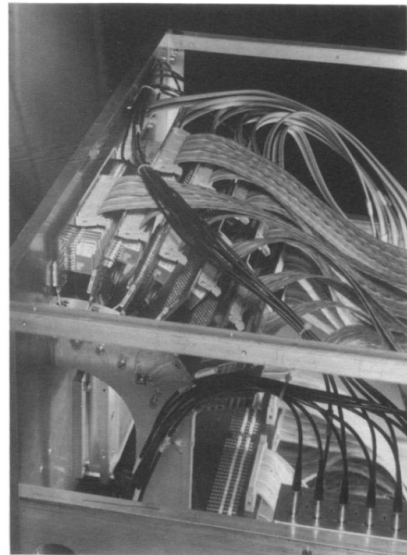

Most devices discussed today will be based on **segmented p-n junction diodes**.

Silicon Detectors Throughout The Years

- Silicon strips
- Multiplexing ASICs
- CCDs

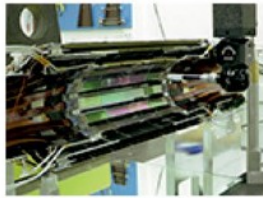

DELPHI

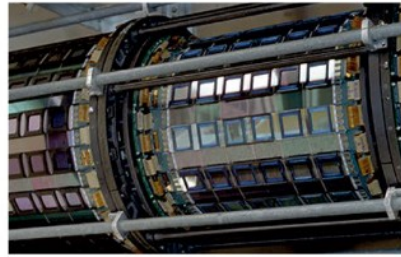

CDF

- CMOS MAPS
- Silicon-on-insulator pixels
- Vertical 3D integration



CMS

1980

1990

2000

2010

NA14



- Hybrid planar pixels
- Drift detectors
- DEPFET
- Hybrid 3D pixels

STAR



Belle II

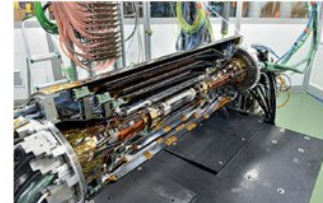

- Depleted MAPS
- Fast-timing detectors
- Hybrid MAPS

Credit: Applications of silicon strip and pixel-based particle tracking detectors

Silicon Detectors Throughout The Years

Follows Moore's Law!

“the number of transistors in an integrated circuit (IC) doubles about every two years”

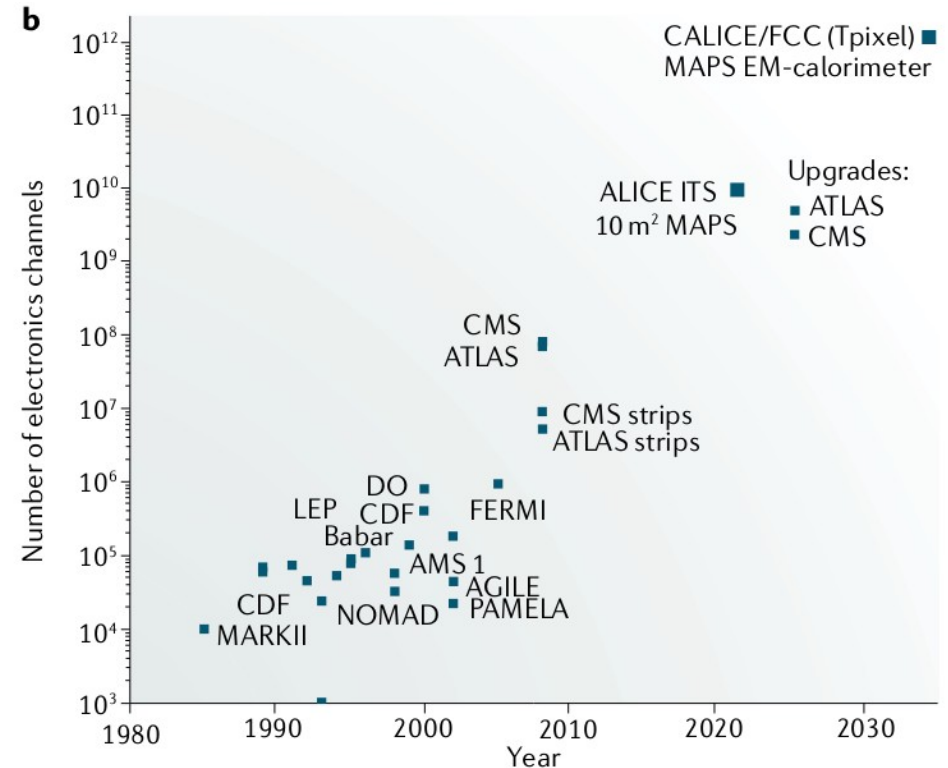
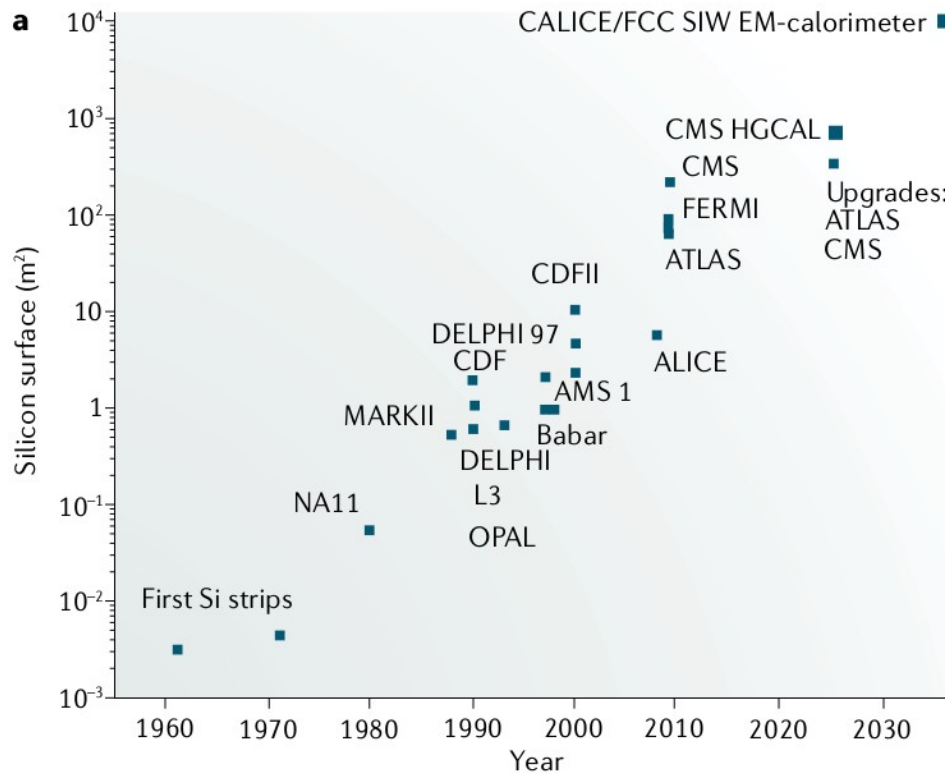

Credit: [Applications of silicon strip and pixel-based particle tracking detectors](#)

Fast Recap of p-n Junction: Doping

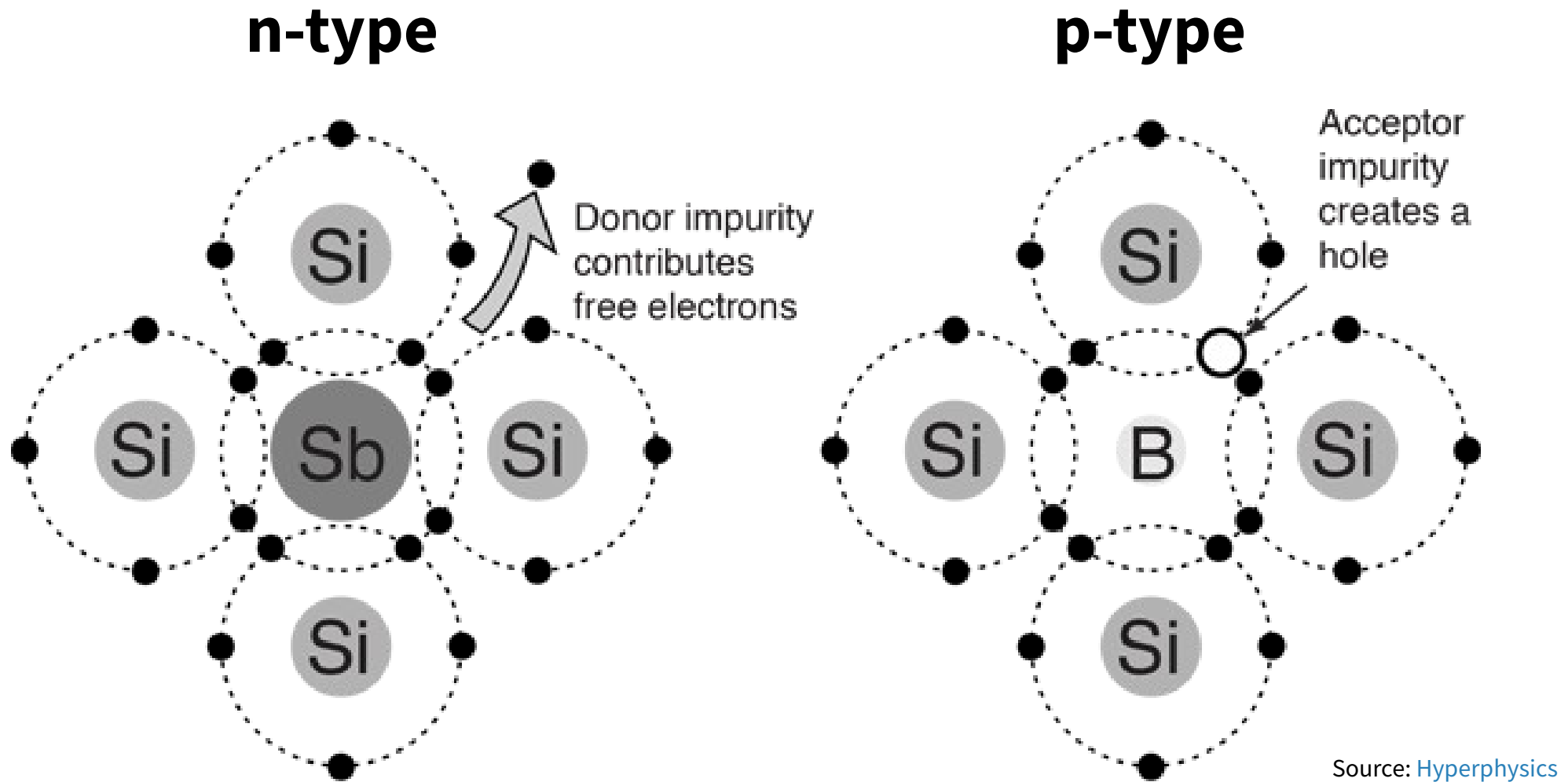

Two types of doped silicon.

Fast Recap of p-n Junction: Junction

+: **holes** = electrons missing in covalent bonds

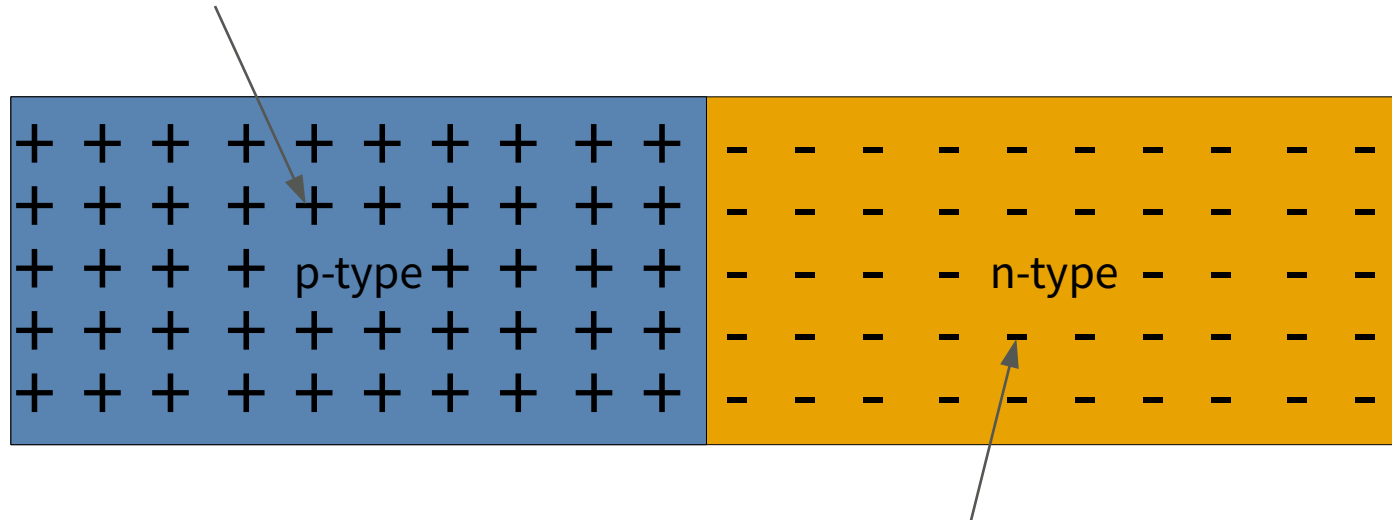

- : **free electrons** = electrons outside pf covalent bonds

Note: The entire material is neutral! $N_{\text{electrons}} = N_{\text{protons}}$

Fast Recap of p-n Junction: Equilibrium

Small depletion region as some electrons flow into holes.

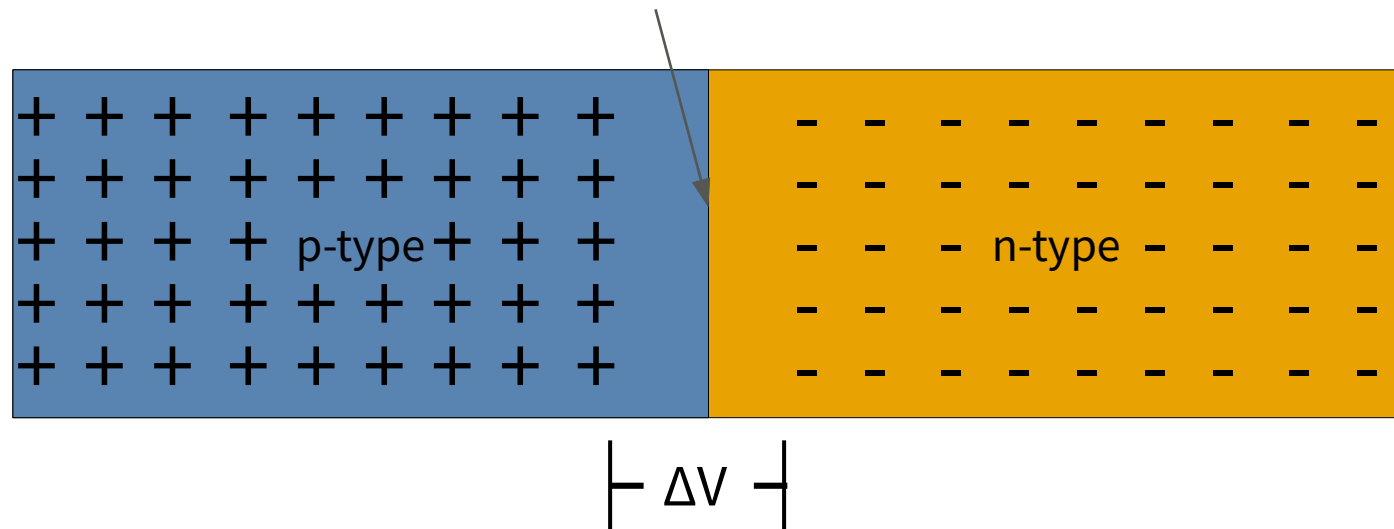

Fast Recap of p-n Junction: Reverse Biased Junct.

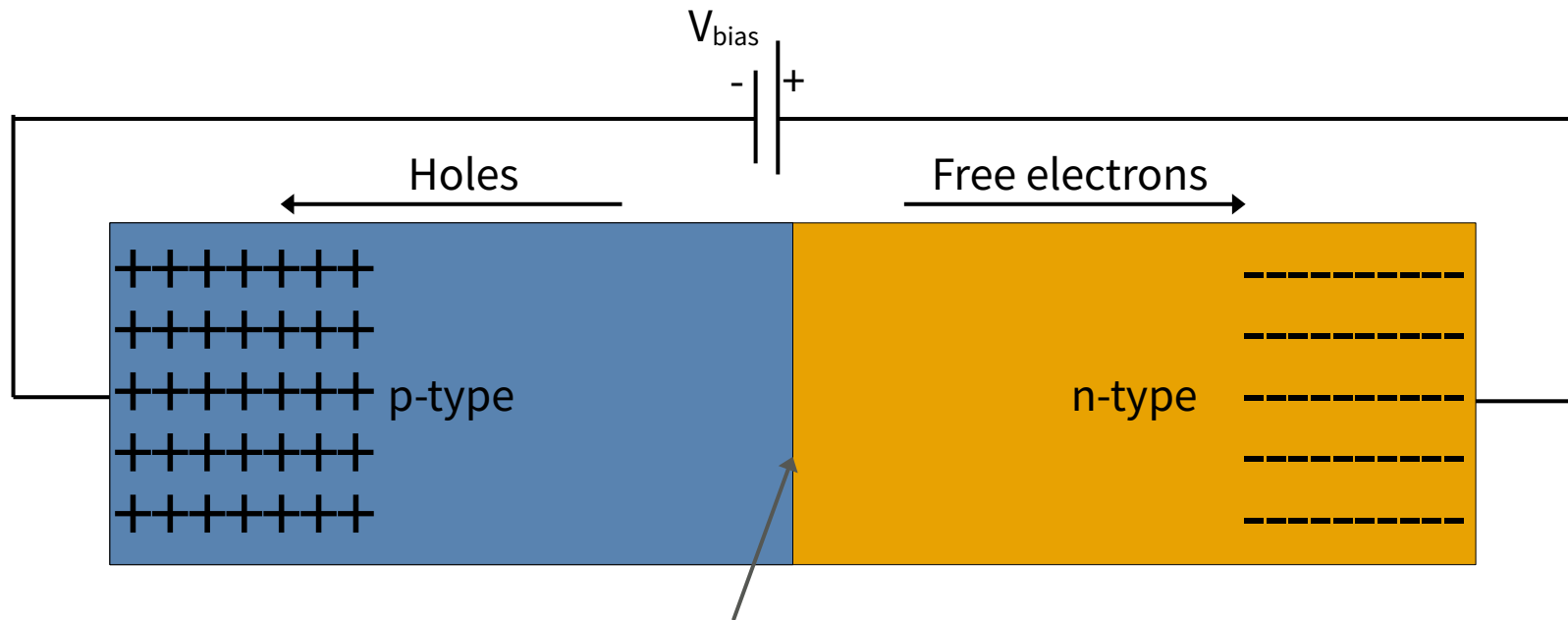

Depletion region:

- Missing holes and free electrons in the middle.
- Develops ΔV opposing V_{bias} at equilibrium.
- ΔV prevents any current from flowing.

Fast Recap of p-n Junction: IV Curve

$$J = J_0 \left(e^{\frac{qV}{kT}} - 1 \right)$$

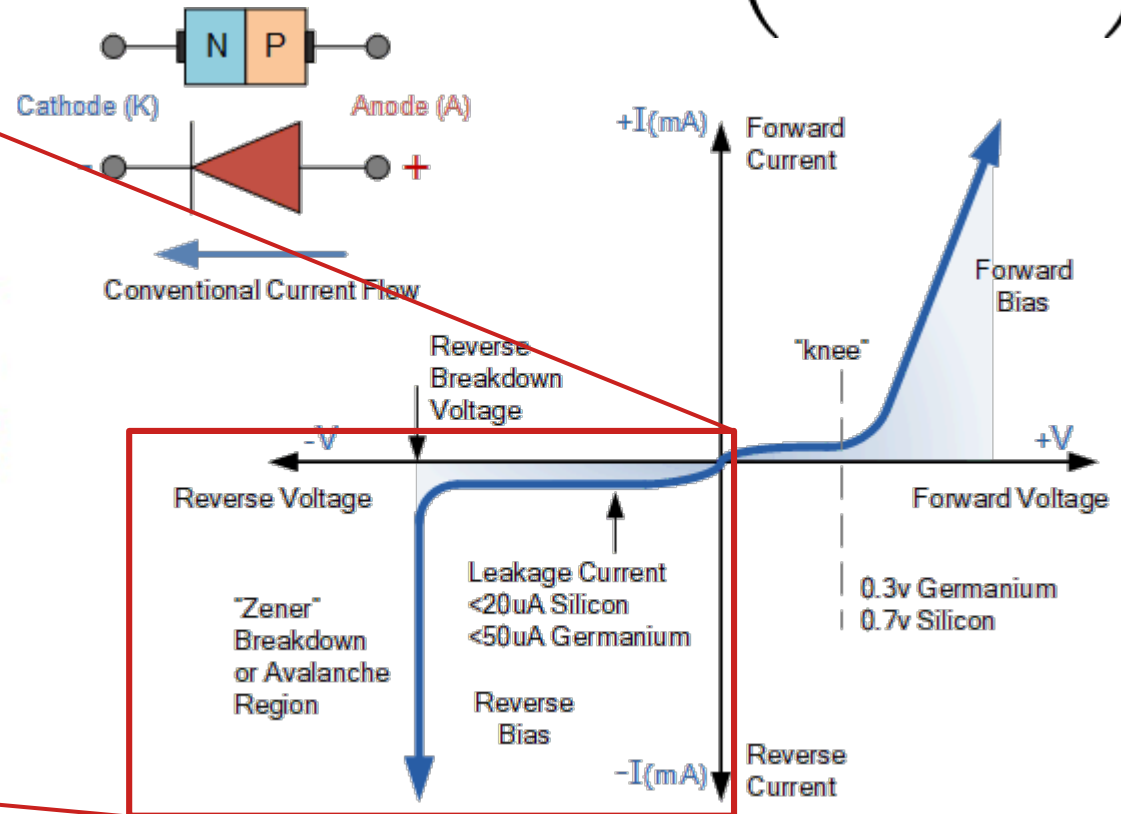
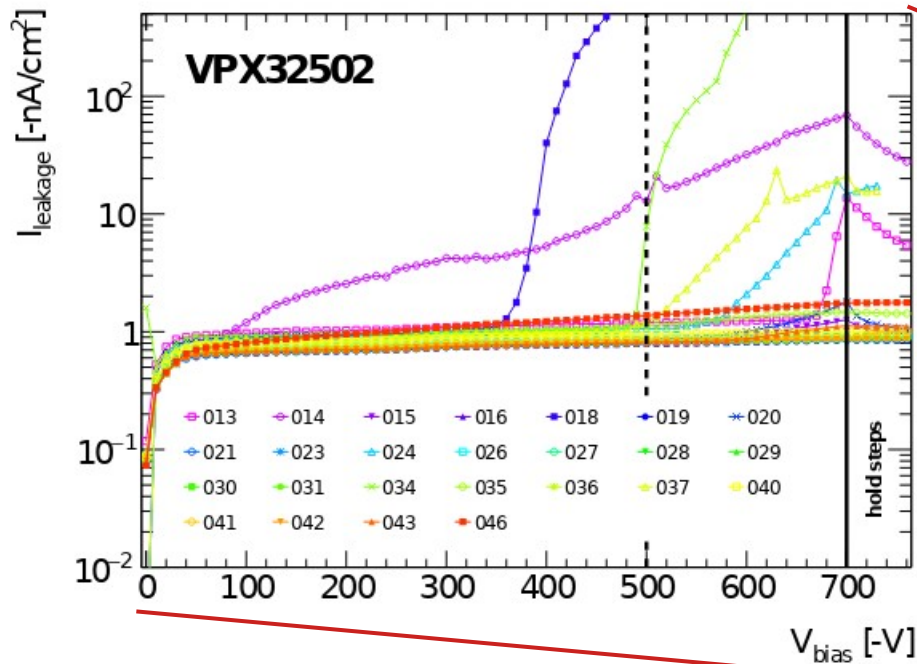

Sensors operate in Reverse Bias

Credit: PN Junction Diode

Credit: ATLAS ITk Strip Sensor Quality Control and Review of ATLAS18 Pre-Production Sensor Results

Space Charge Region

Consider a 1D sensor. Following Poisson's equation

$$\frac{d^2V}{dx^2} = -\frac{\rho}{\epsilon} \quad \begin{array}{l} \rho = \text{charge density} \\ \epsilon = \text{dielectric constant} \end{array}$$

Assume all dopants ionized up to a in n-type and b in p-type

$$\rho_n = eN_n \quad \text{n-type} \quad \rho_p = -eN_p \quad \text{p-type}$$

Integrate once to get E-field as linear

$$E = \frac{eN_n}{\epsilon} (a + x), \quad -a < x < 0$$

$$E = \frac{eN_p}{\epsilon} (b - x), \quad 0 < x < b$$

E must be continuous at $x=0$

$$aN_n = bN_p$$

Integrate again to get voltage

$$V = -\frac{eN_n}{2\epsilon} (x + a)^2 + V_0, \quad -a < x < 0$$

$$V = +\frac{eN_p}{2\epsilon} (x - b)^2, \quad 0 < x < b$$

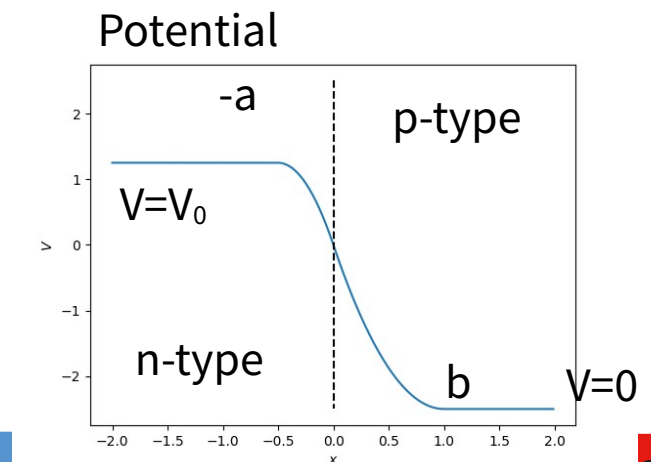
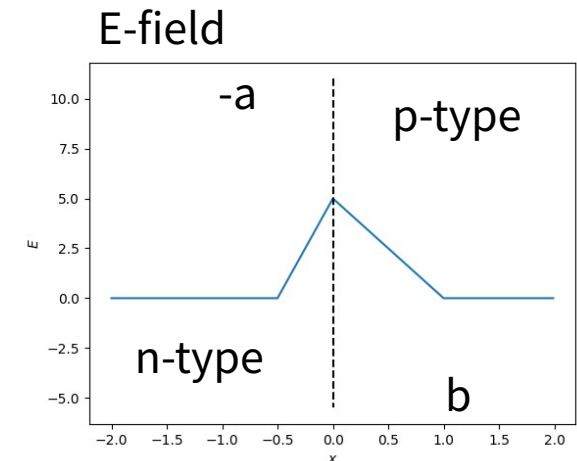
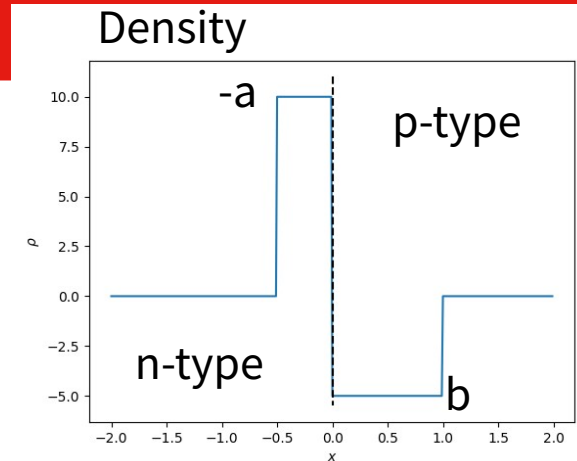

Depletion Depth

Require potential to be continuous at $x=0$

$$\frac{eN_p b^2}{2\epsilon} = V_0 - \frac{eN_n a^2}{2\epsilon}$$

Solving for applied voltage, V_0 , and applying E-field continuity

$$V_0 = \frac{e}{2\epsilon} (N_p b^2 + N_n a^2) = \frac{e}{2\epsilon} N_p b (b + a)$$

Take $N_n \gg N_p$, making $b \gg a$. $aN_n = bN_p$

$$V_0 = \frac{e}{2\epsilon} N_p b^2$$

Solving for distances.

$$b \approx \sqrt{\frac{e\epsilon V_0}{eN_p}}, N_n \gg N_p \quad a \approx \sqrt{\frac{e\epsilon V_0}{eN_n}}, N_p \gg N_n$$

Or more generally, take $N_{\min} = \min(N_p, N_n)$

$$d \approx \sqrt{\frac{e\epsilon V_0}{eN_{\min}}}$$

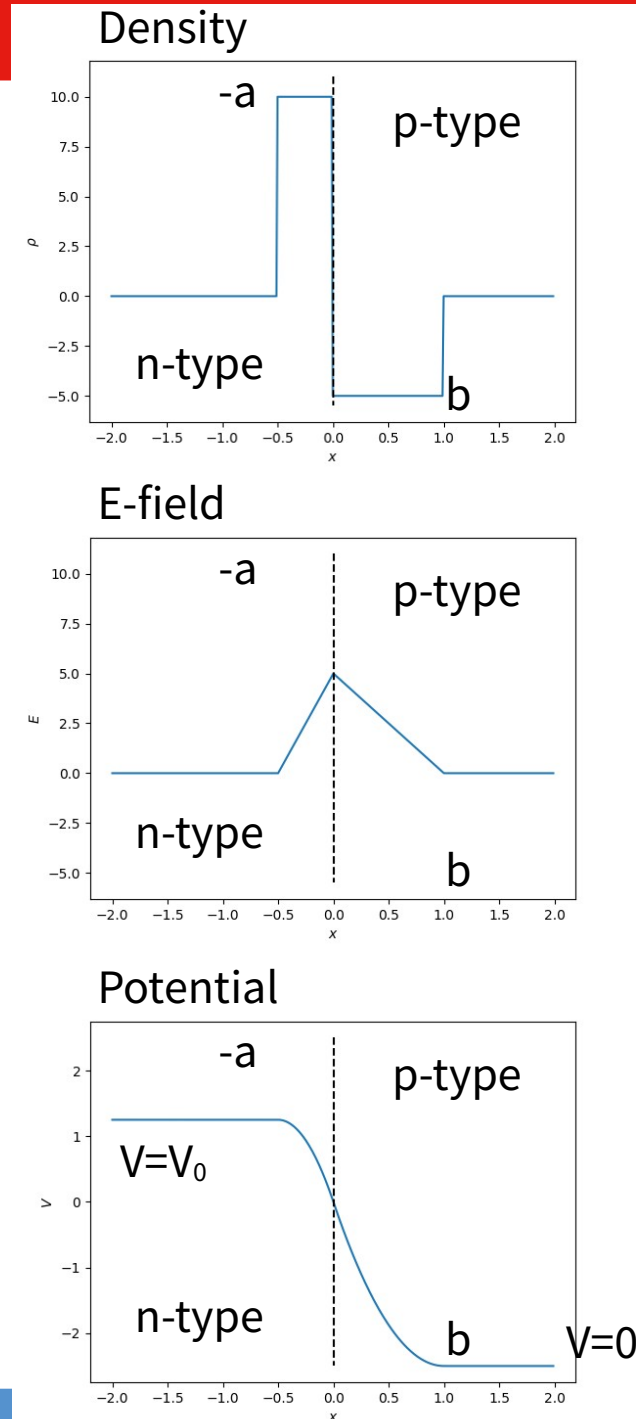

Depletion Layer

Treat depletion layer as parallel plate capacitor

$$C(V) = \frac{\epsilon_0 \epsilon_{r, Si} A}{d(V)} \quad \frac{1}{C^2} \propto V$$

Measure capacitance to find

- N_{\min} (doping amount)
- Substrate resistivity

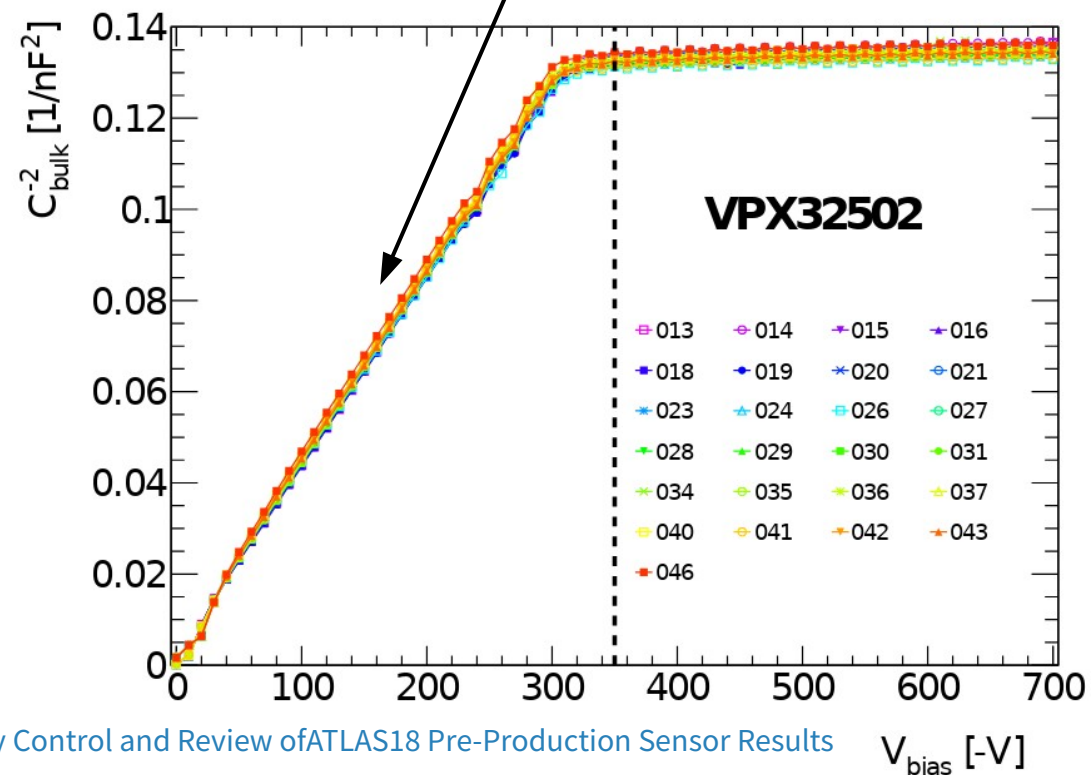

Credit: ATLAS ITk Strip Sensor Quality Control and Review of ATLAS18 Pre-Production Sensor Results

How A Sensor Works

A sensor is just a **reverse biased diode**.

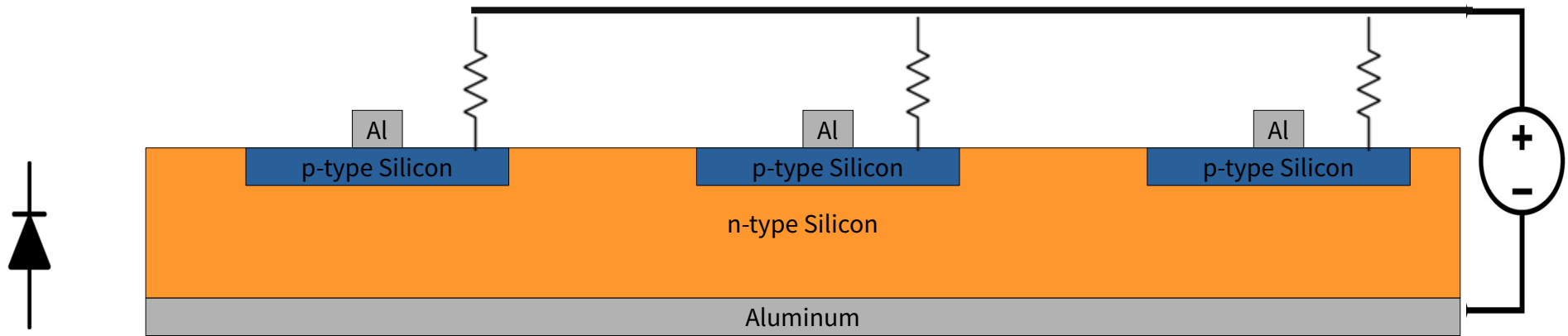

Bonus Topic: How do p-n junctions (diodes) work?

How A Sensor Works

Electric field is formed inside an **insulator**.

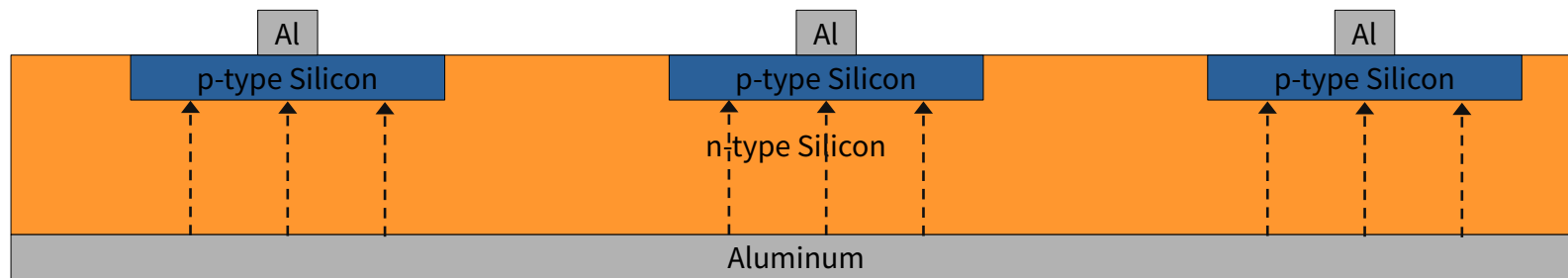
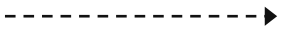

Bias voltage is still here, just not shown.

How A Sensor Works

Passing particle excites electrons (**ionizes**) into conducting band.

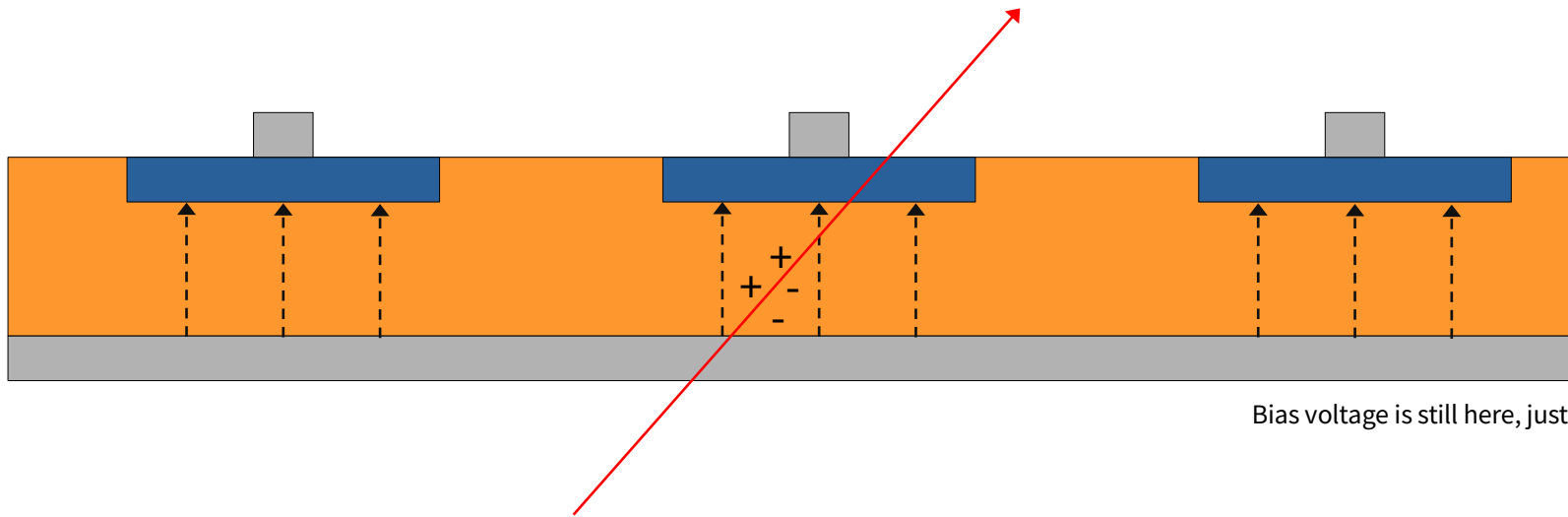

How A Sensor Works

Electron/hole pairs travel, creating detectable current.

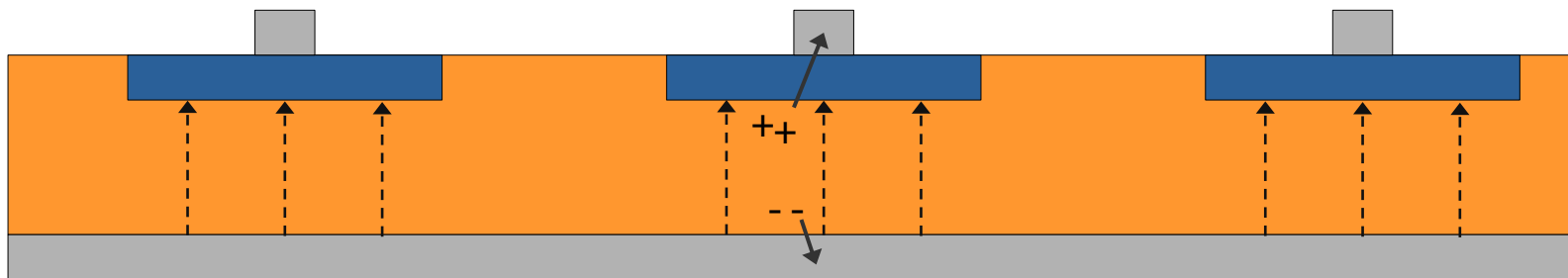

Bias voltage is still here, just not shown.

Silicon Drift Detectors

Use **drift time** to **determine incidence position**.

Like a gas drift chamber, but in solid state.

- Few readout channels.
- Only for low flux of particles.
- **Electron mobility, μ , varies**
 - Inhomogenities
 - Radiation damage

$$v_{\text{drift}} = \mu E$$

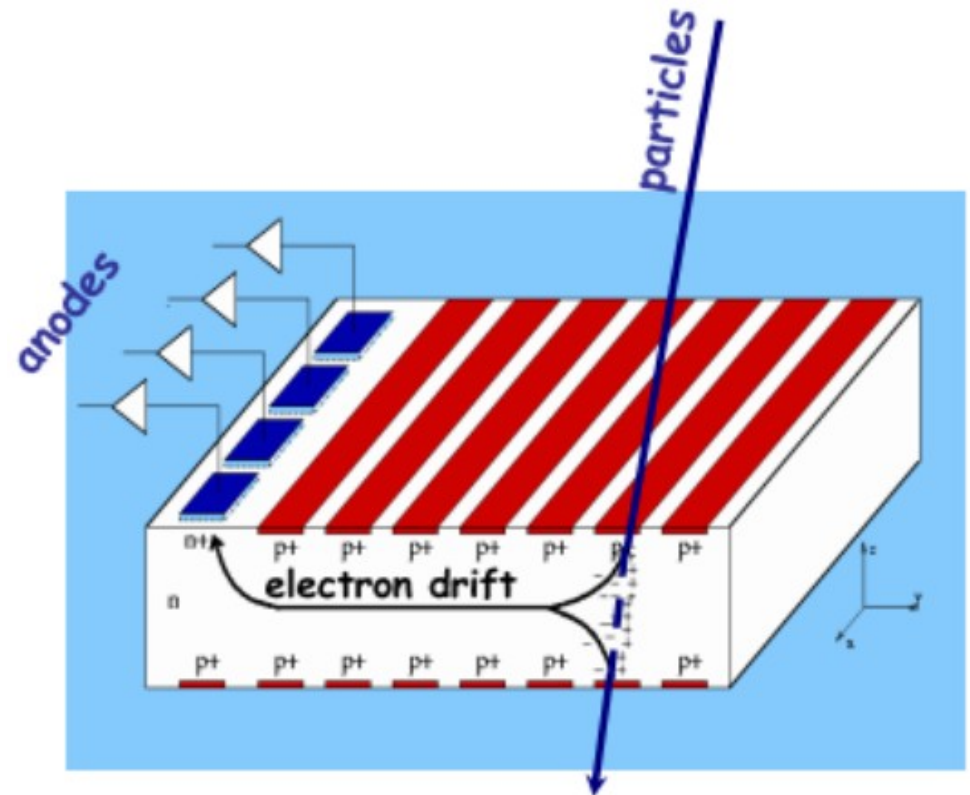

Hybrid Detectors

Readout electronics on **PCB's** glued to **silicon** sensors.

Individual connections to segmented channels in the sensor.

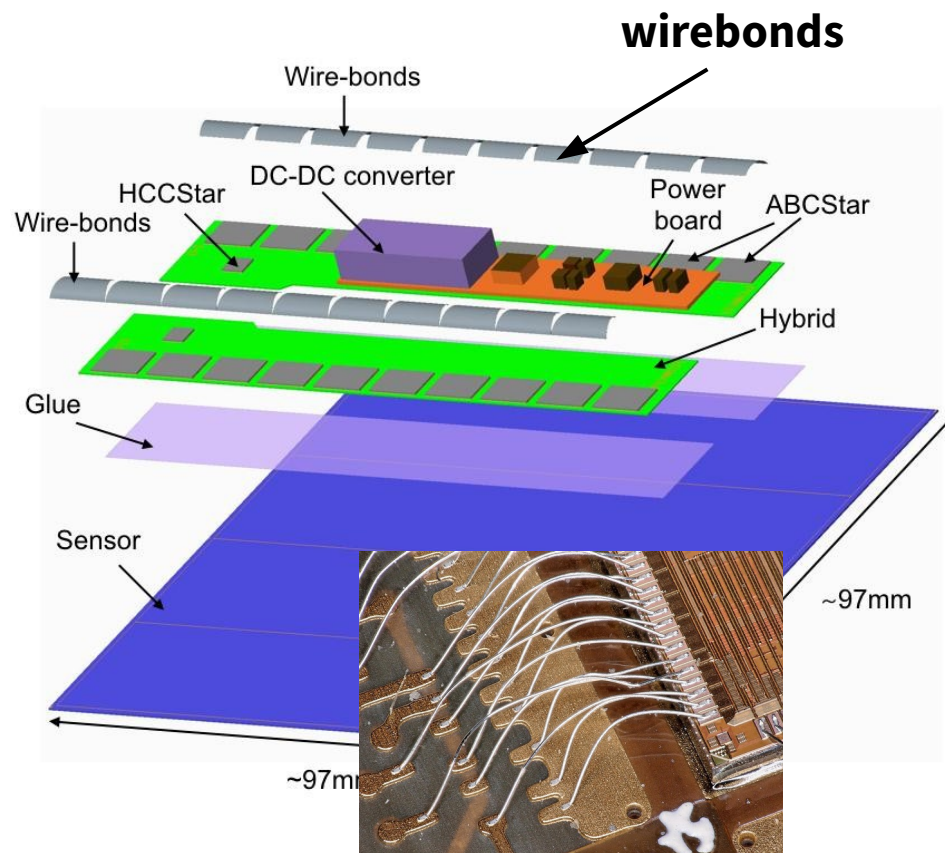
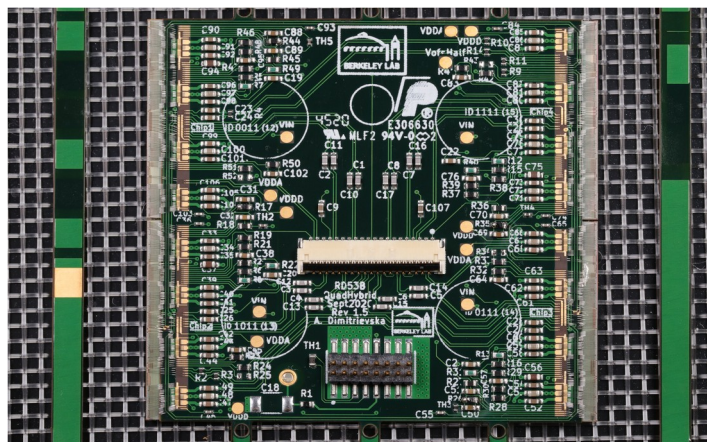
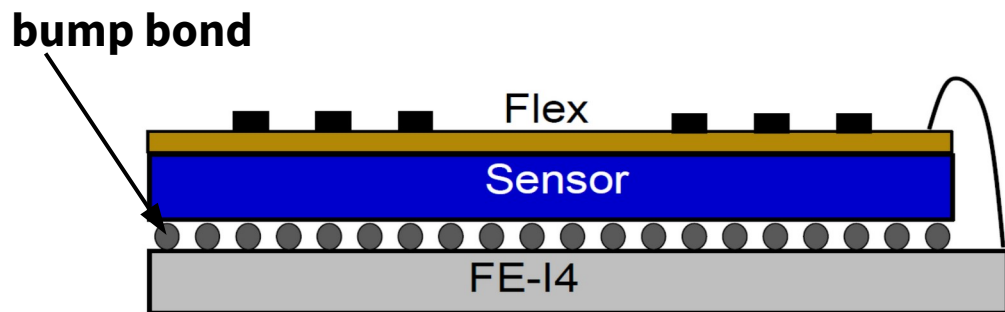

ex: ASIC wirebonded to PCB

Strips Vs Pixels

A **pixel** is just a short **strip**.

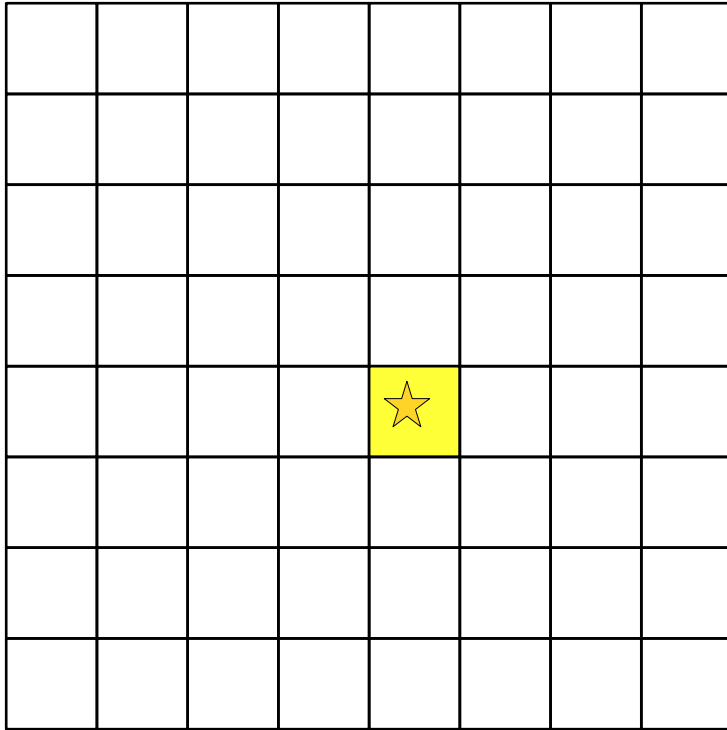

ITk Pixel example: 50 μm x 50 μm

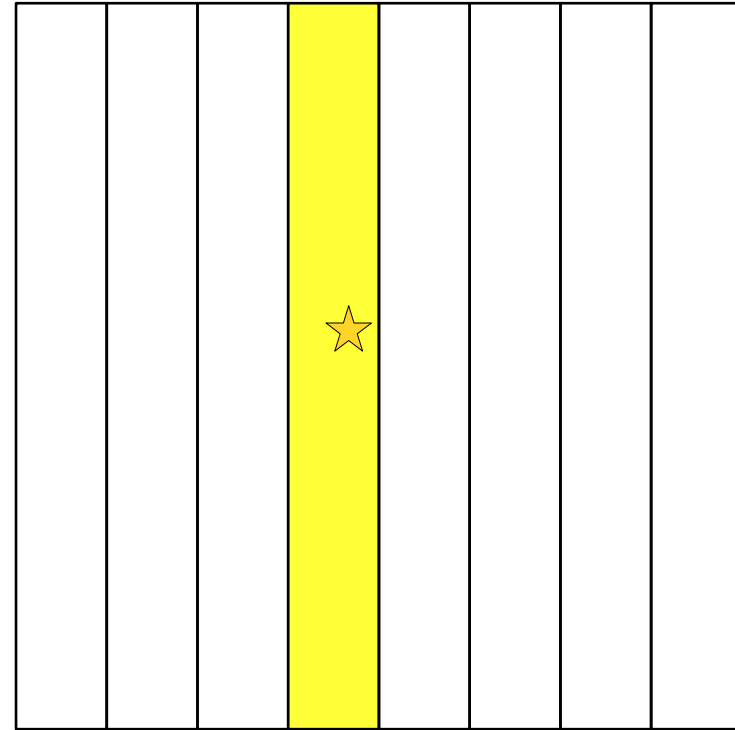

ITk Strip example: 75 μm x 5 cm

Defines the segmentation
of the sensitive part.

Question:

- When do you use a strip vs pixel sensor?
- How to make a strip give a 2D position?

Charged Coupled Devices (CCD)

1) Use a SiO_2 (insulator) layer to trap charge.

2) Scan through pixelated contacts, transferring charge one at time.

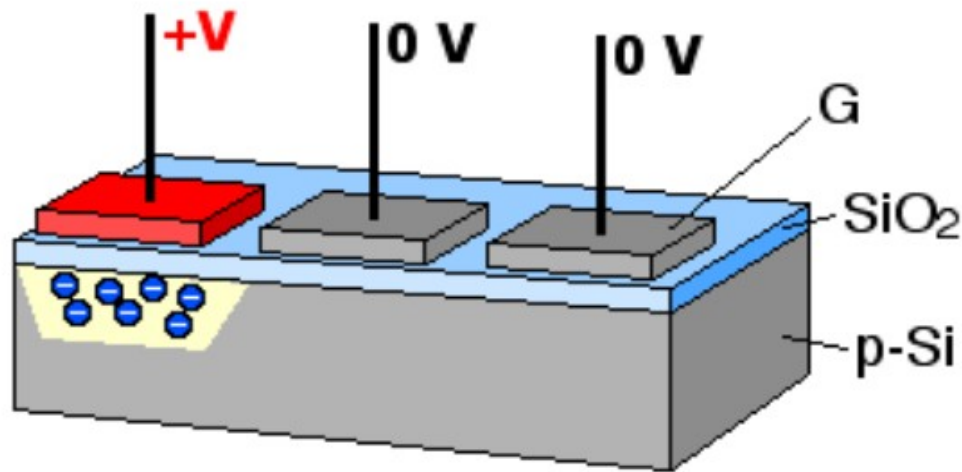

- **Shared readout electronics.**
 - Multiple channels with less space ($\sim \mu\text{m}$ pixels)
- **Very slow readout.**
- **Sensitive to radiation damage.**

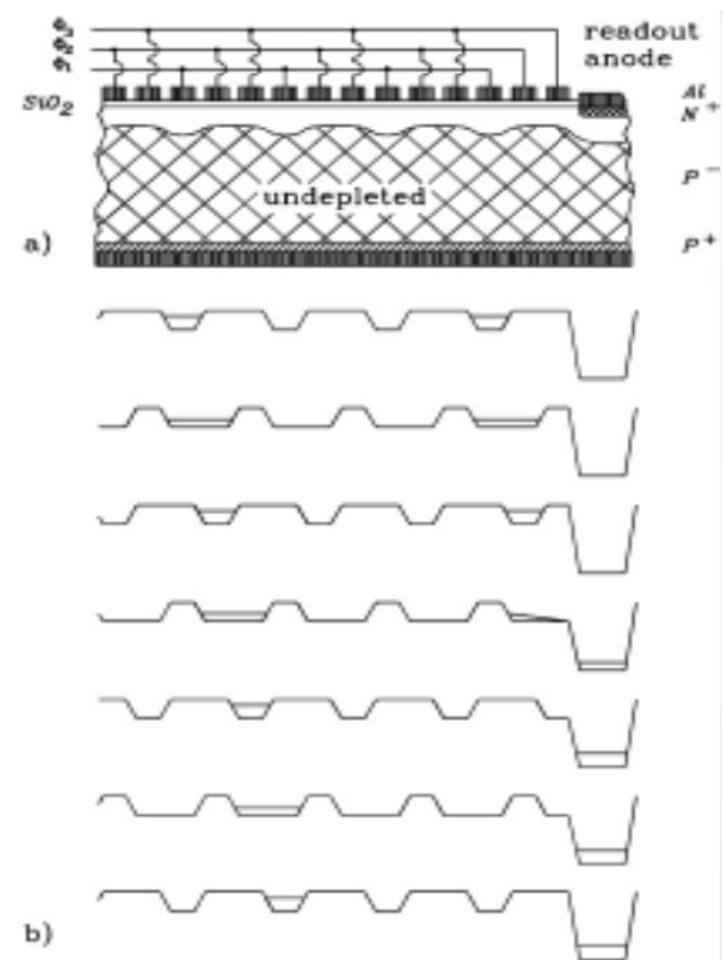

Charged Coupled Devices (CCD)

- **Heavily used for optical imaging.**
 - Examples: cameras, x-ray imaging, telescopes astronomy
- **Need to mask detector during readout to avoid smearing.**
 - Cameras mask out adjacent column, transfer to it after exposure and readout.
- **Most commercial systems moving to CMOS Imaging Sensors.**

DAMIC experiment searches for DM-nucleus recoil inside CCDs.

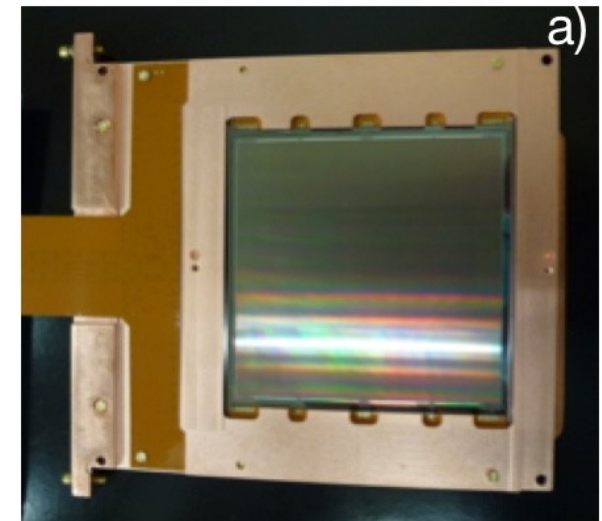
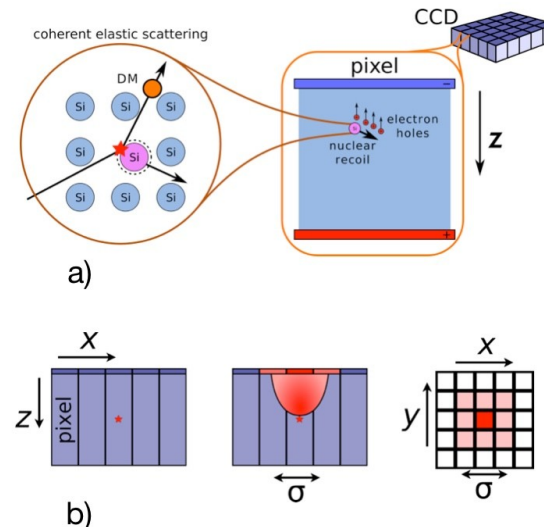

Combine **sensor** (silicon) with **readout** electronics (silicon).

You save half construction time by no mention of glue in meetings.

- Using CMOS technology for both readout and imaging
 - \$\$\$\$ industry (phone cameras!)
- Main challenge is making them radiation hard.

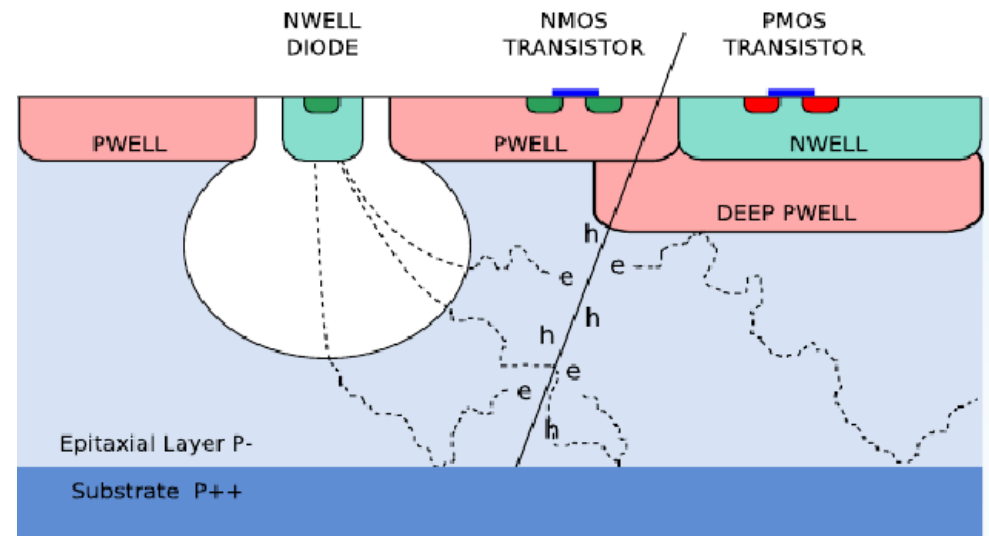

MAPS = Monolithic Active Pixel Sensor

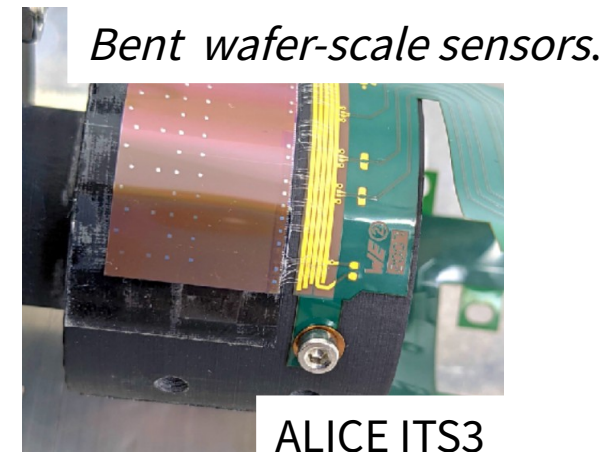

Fast Timing Detectors (4D Tracking)

Future detectors require timing ($\sim ps$) in addition to position.

BIB rejection in Muon Collider Detector.

Timing resolution limited by electron drifting to anodes

- $v_{\text{drift}} \approx 100 \text{ } \mu\text{m} / \text{ns}$
- $t_{\text{collection}}(300 \text{ } \mu\text{m}) \approx 3 \text{ ns}$

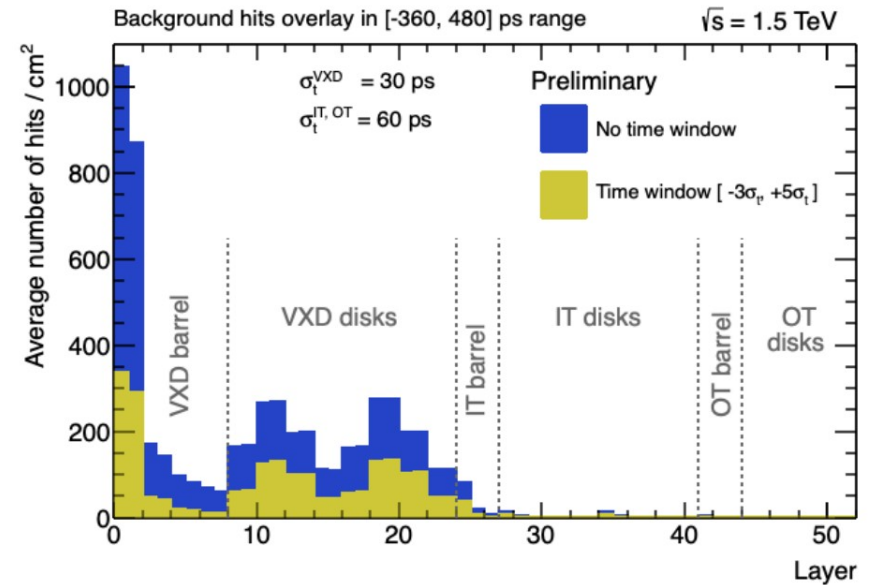

Vertex discrimination in FCCh

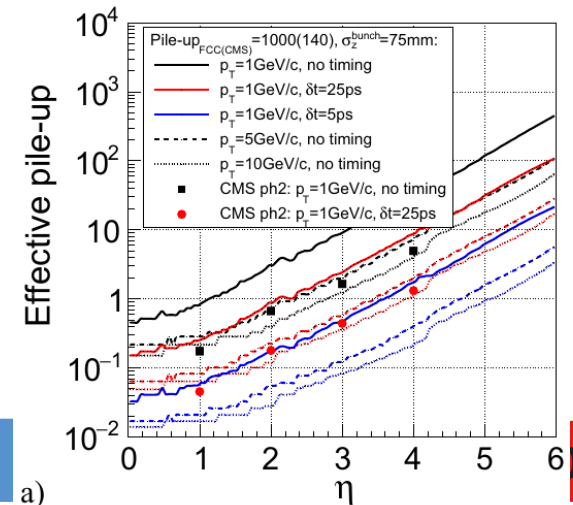

Shorten drift time by making sensors thinner!

- Thinner sensors collect less charge.
 - Lower signal-to-noise.
- LGADs add a “**gain layer**” with very **high E field** to cause an **avalanche**.
- Radiation damage is biggest challenge
 - Gain layer becomes less efficient.
- Part of HL-LHC upgrades for a fast timing calorimeter layer (BIG pixels).

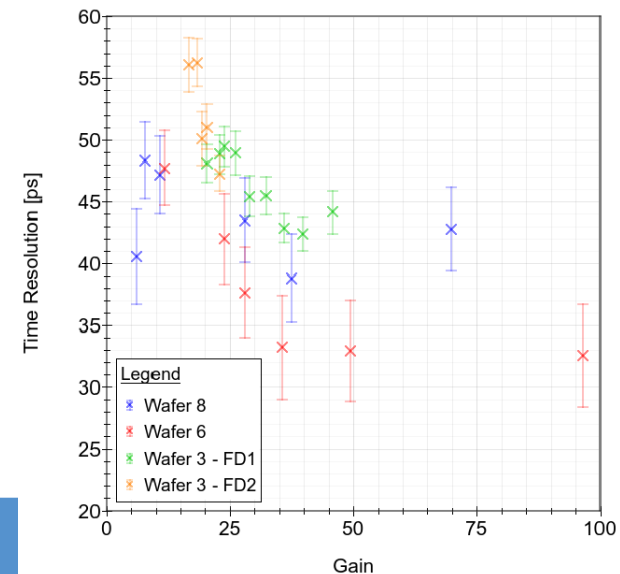
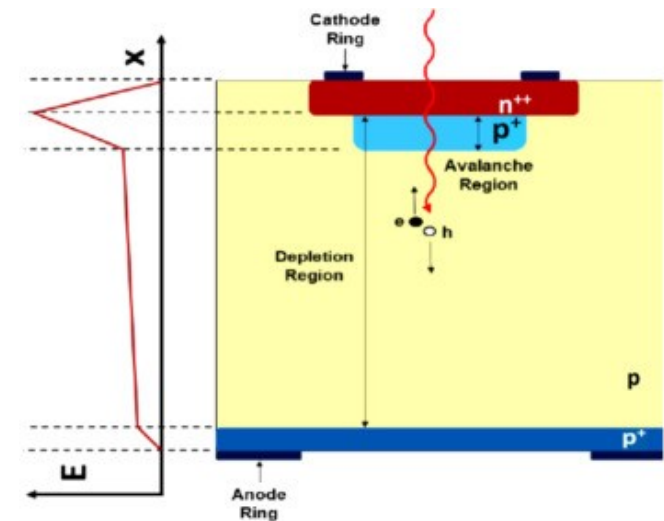

Shorten drift time by putting cathodes into bulk!

- No need for a gain layer.
- Used in part of ATLAS detector.
 - Test of technology.
- Good radiation hardness.

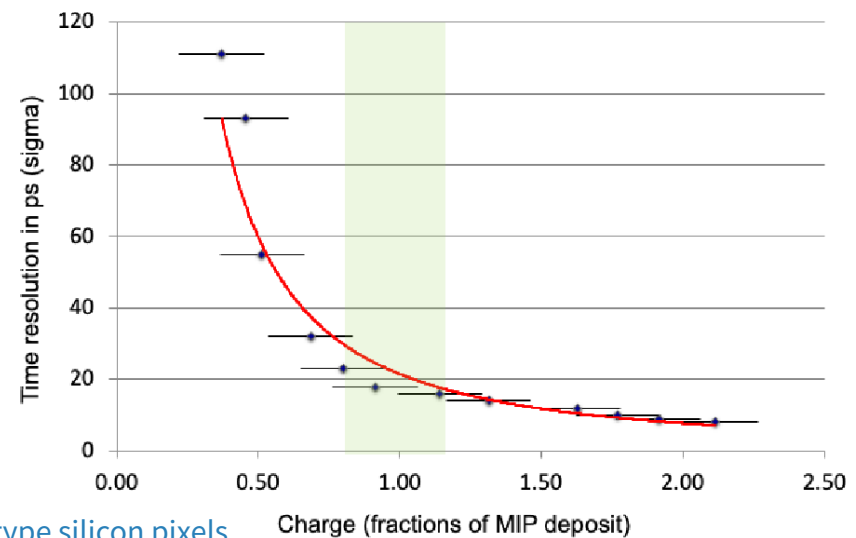
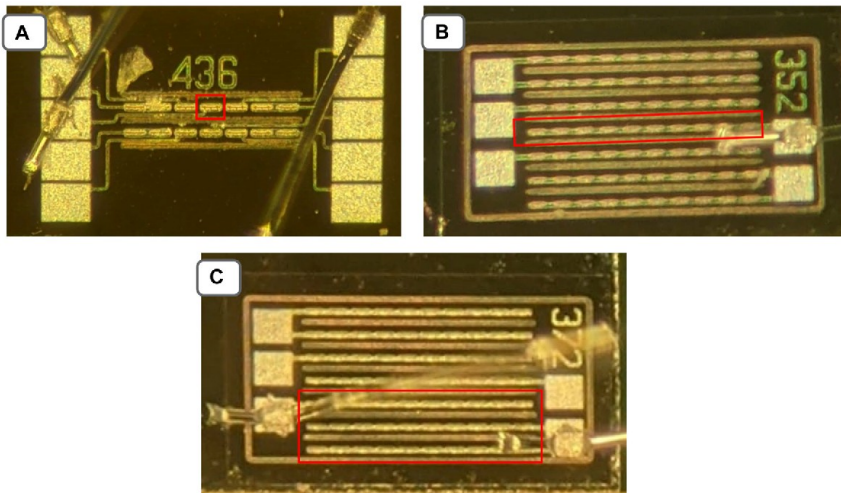
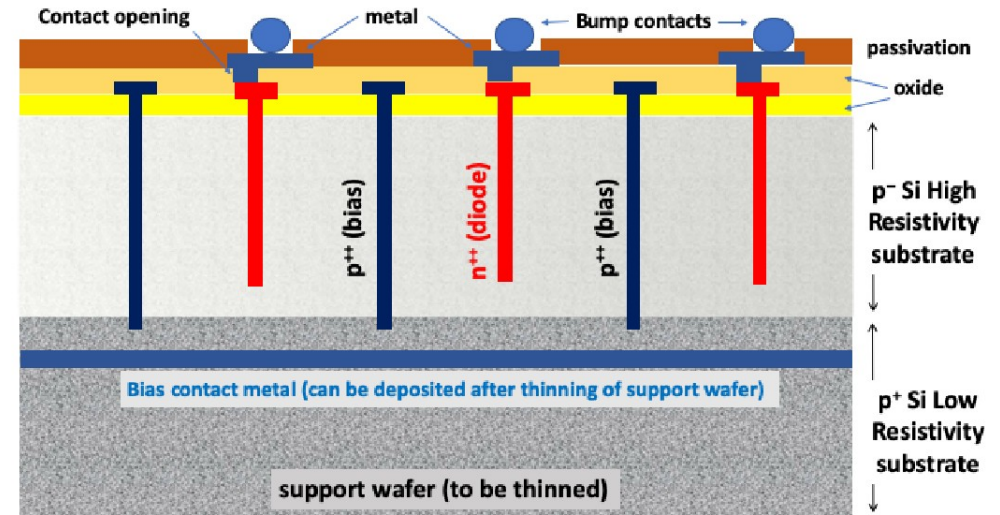

Credit: Charged-particle timing with 10 ps accuracy using TimeSPOT 3D trench-type silicon pixels

Pulse Mode Ionization Chambers

Example to illustrate concept

- Chamber filled with gas.
- Two parallel plates with voltage.

Operation

- 1) Traversing charged particle ionizes gas atoms.
- 2) Ions drift toward cathode, electrons drift toward anode.
- 3) Charge* is as a pulse in the current.

Credit: [Wikipedia](#)

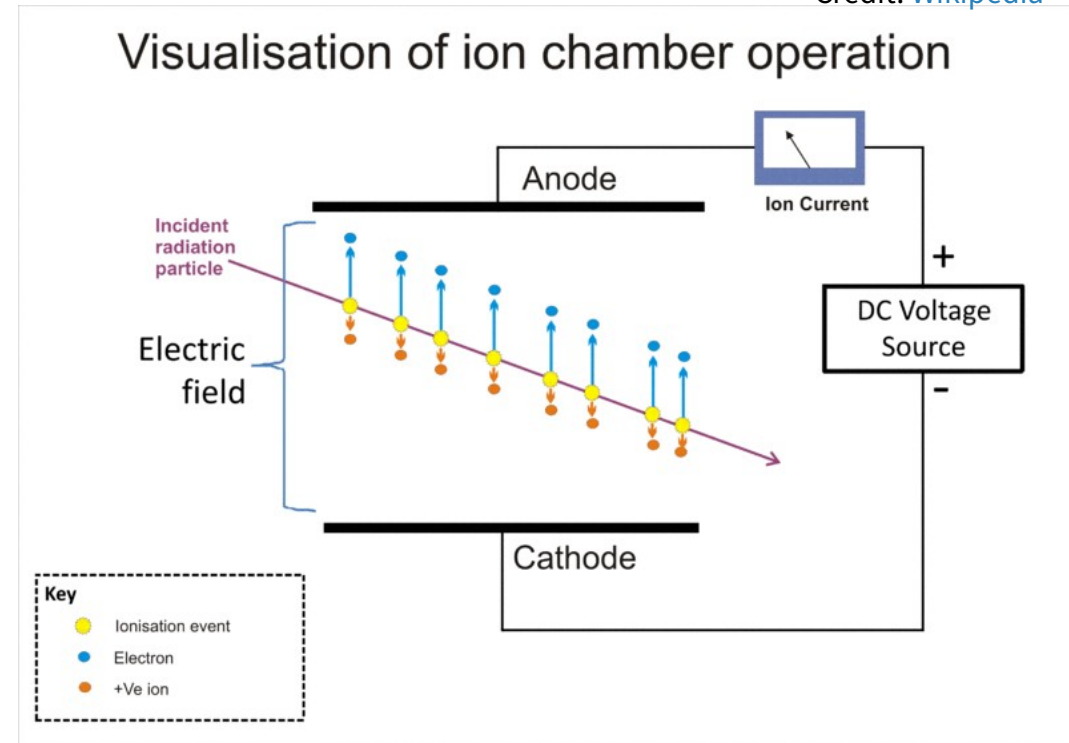

* Current is not arrival of charges at plates. It happens “instantly” via changes (new charges) in the E-field. See Shockley–Ramo theorem.

Pulse Mode Ionization Chambers

Credit: Wikipedia

What is the size of pulse?

- V_R = voltage across sense resistor in “Ion Current”
- V_0 = voltage on DC source
- $\frac{1}{2}CV^2$ = energy stored in plates

From energy conservation:

$$\frac{1}{2}CV_0^2 = \frac{1}{2}C(V_0 - V_R)^2 + qEd_+ + qEd_-$$

Initially: Voltage on plates is from PS.

$$V_0 = V_R + V_{\text{plates}}$$

work done by moving charge

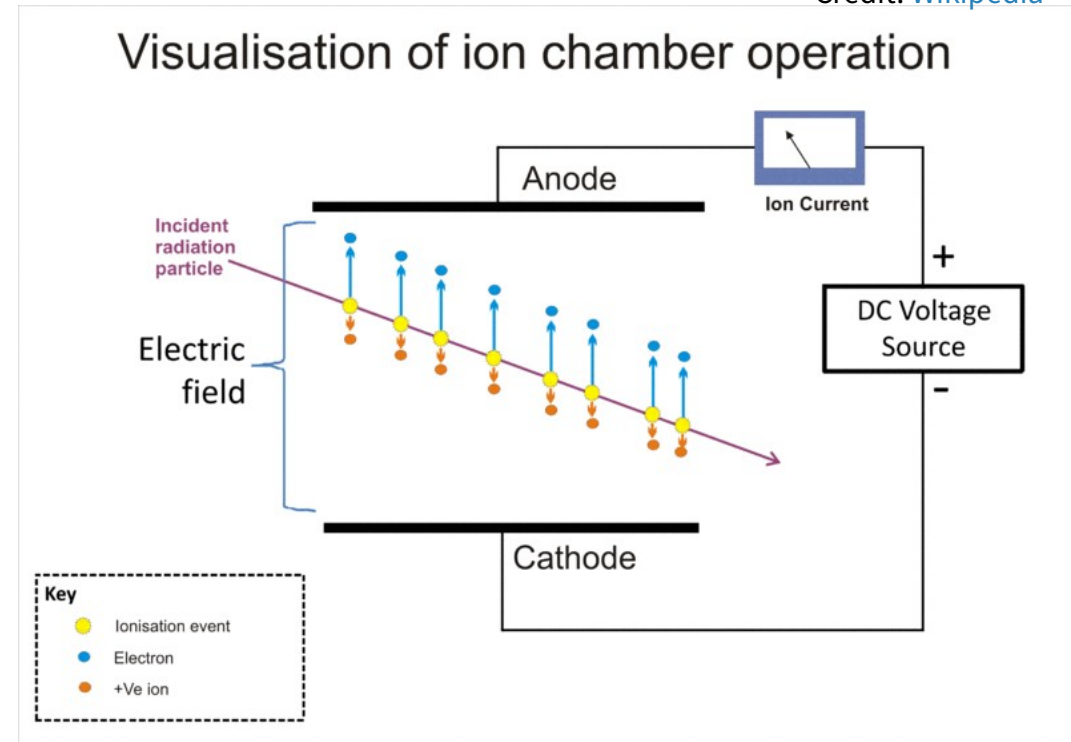

Pulse Mode Ionization Chambers

$$\frac{1}{2}CV_0^2 = \frac{1}{2}C(V_0 - V_R)^2 + qEd_+ + qEd_-$$

Expand and rearrange

$$CV_0V_R - \frac{1}{2}CV_R^2 = qE(d_+ + d_-)$$

Assume $V_R \ll V_0$

More rearranging, $E=V_0/d$

$$V_R = \frac{qE}{CV_0} (d_+ + d_-) = \frac{q}{Cd} (d_+ + d_-)$$

Distance by ions / electrons transverse the plates... $d_+ + d_- = d$

$$V_R = \frac{q}{C}$$

Pulse proportional to charge!

Pulse Mode Ionization Chambers

Regions of Gaseous Ionization Detectors

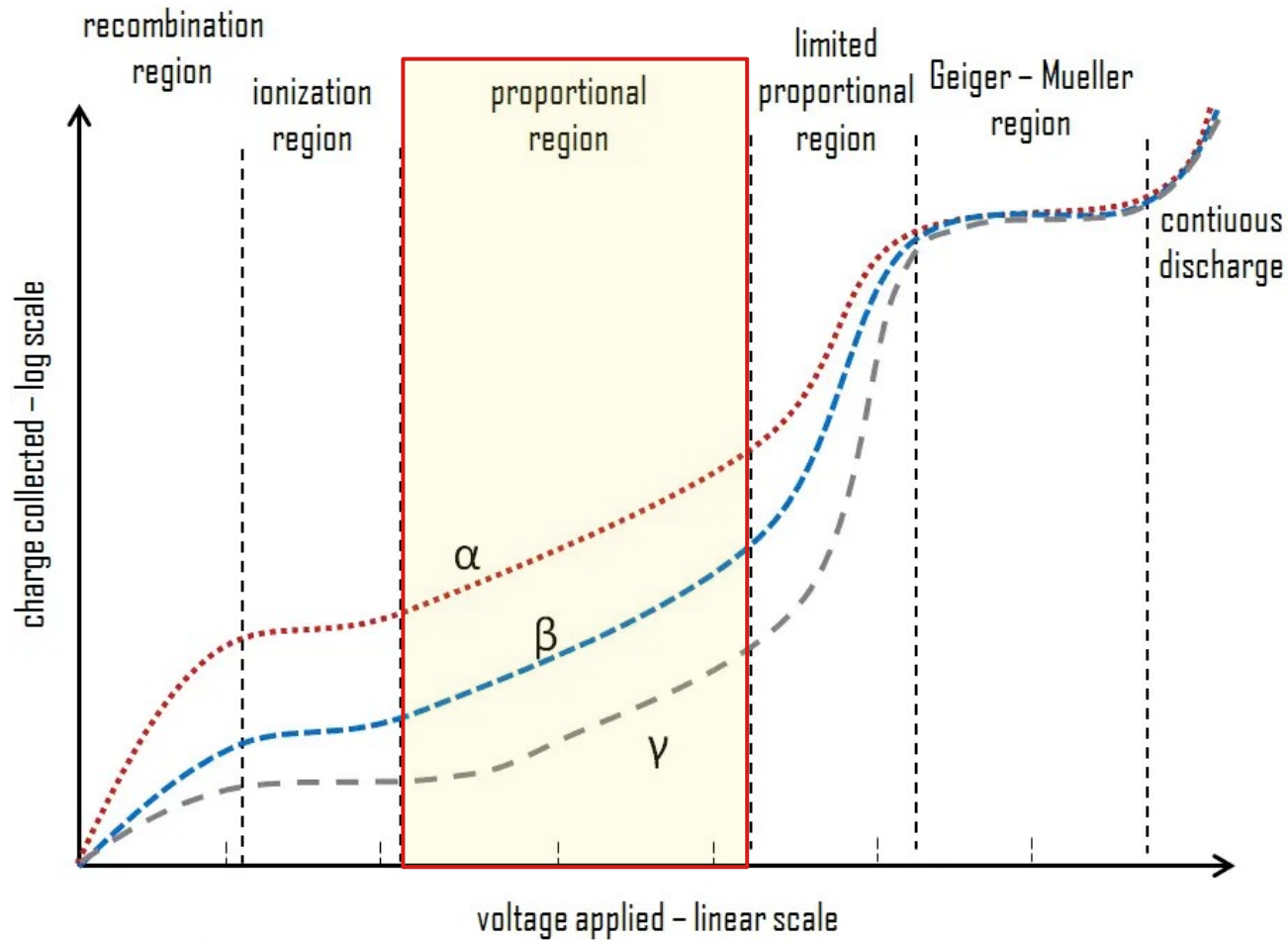

www.nuclear-power.net

Credit: [What is Proportional Region - Ionization Detector - Definition](#)

Geiger-Muller Region

- Ionized electrons gain energy as they are accelerated.
- At high energies, they can ionize further atoms.
 - Starts to happen at $\sim 10^6$ V/m.
- Repeat... you get an avalanche.

Credit: [Wikipedia](#)

Usual Geiger-Muller detector

- Cylindrical geometry with a thin wire.
- Electric field is proportional to $1/r$.
- Avalanche will occur close to the thin wire.

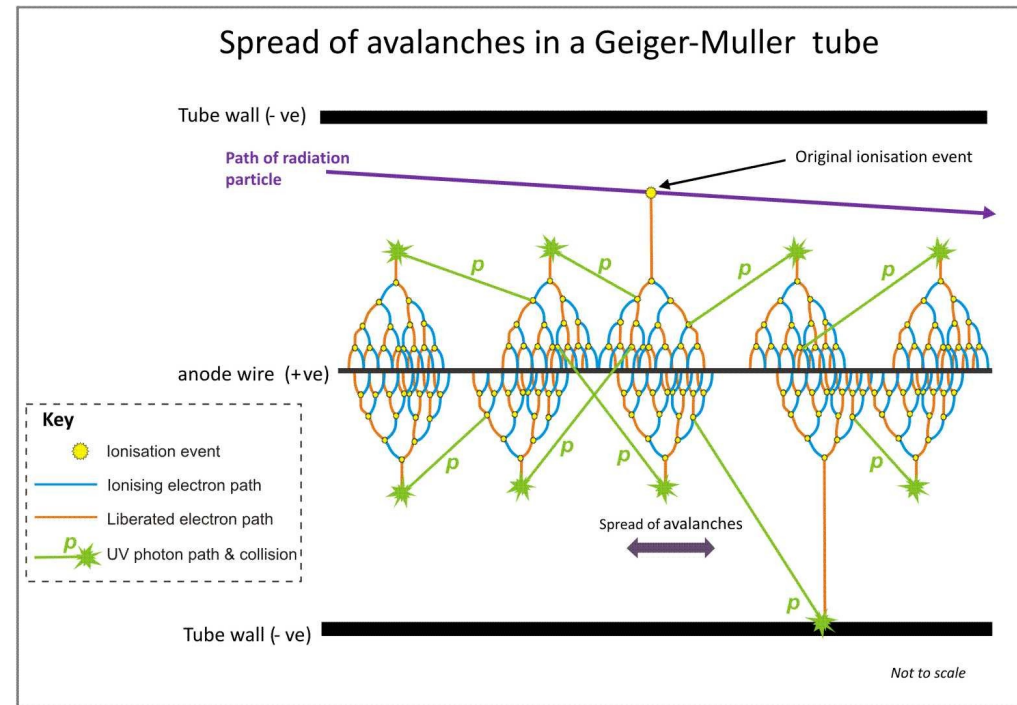

Formation of Avalanche

E-field in cylinder

$$E(r) = \frac{V}{r \ln\left(\frac{b}{a}\right)}$$

$a \approx 100 \mu\text{m}$, $b \approx 1\text{cm}$ $\rightarrow 10^6 \text{V/m}$ when $r < 0.2 \text{mm}$

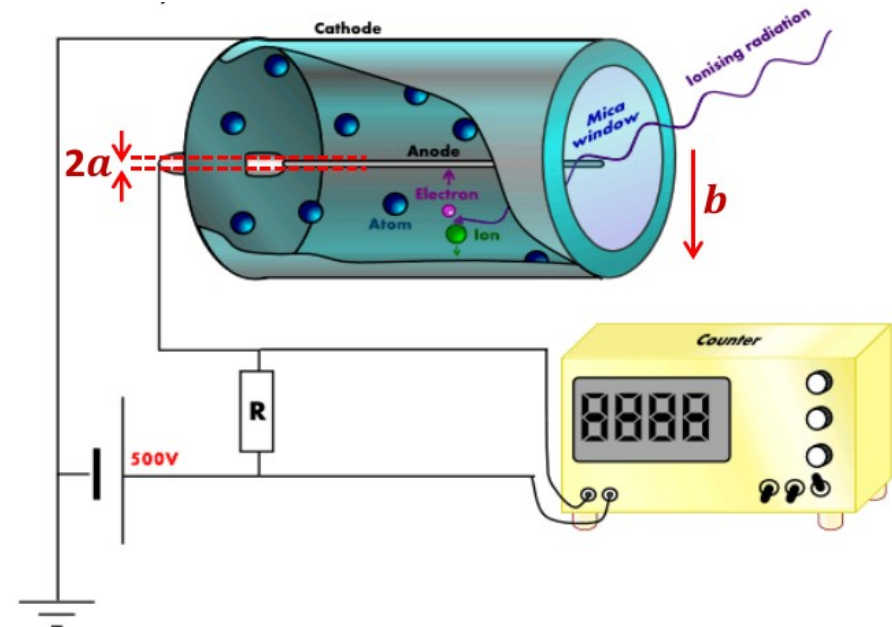

- **Electron contribution very small \rightarrow short distance traveled**
 - Pulse mostly from positive ions.
- **Positive ions take long time to travel (heavy)**
 - Pulse develops much faster (Shockley–Ramo theorem!)

Drift Time of Ions

Starting from drift velocity in cylinders.

$$\frac{dr}{dt} = v_{\text{drift}} = \mu E = \frac{\mu V_0}{\ln\left(\frac{b}{a}\right) r}$$

Integrate to get distance at time t.

$$\int_a^r r dr = \frac{\mu V_0}{\ln\left(\frac{b}{a}\right)} \int_0^t dt$$

Start at anode (formation of most ions)

...

$$\frac{1}{2} (r^2 - a^2) = \frac{\mu V_0}{\ln\left(\frac{b}{a}\right)} t$$

Use r=b to get flow from cathode to anode

$$t = \frac{1}{2} (b^2 - a^2) \frac{\ln\left(\frac{b}{a}\right)}{\mu V_0}$$

Formation of Avalanche

Time for furthest ion to reach cathode

$$t = \frac{1}{2} (b^2 - a^2) \frac{\ln \left(\frac{b}{a} \right)}{\mu V_0}$$

$$a \approx 100 \mu\text{m}, b \approx 1\text{cm}, V_0 \approx 1000\text{V}, \mu = 10^{-4} \text{m}^2/\text{Vs}$$

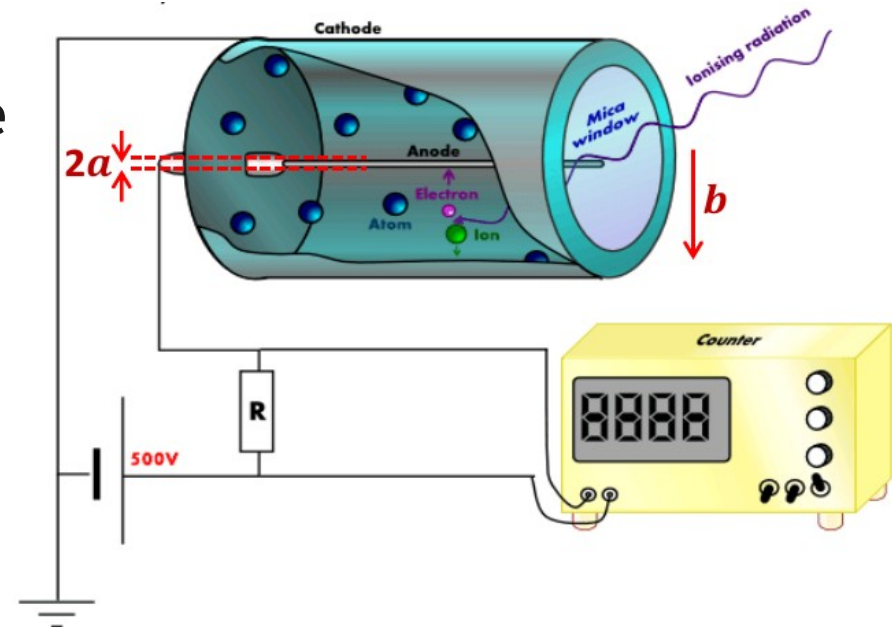

- In a typical detector, this is 2 ms (slow!)
- Half of pulse height achieved when $\ln(r/a) = \frac{1}{2} \ln(b/a)$
 - $r = 0.1\text{cm}$, giving 20us (fast!)

Exercise: use conservation of energy to show that the pulse height after ions traveled a distance r is...

$$V_R = \frac{q}{C \ln \left(\frac{b}{a} \right)} \ln \left(\frac{r}{a} \right)$$

Two Stars and a Wish

Feedback is very welcome!

Two Stars: What are two new things you learned or were explained well?

Wish: What is something you would want to learn about or should be explained better?

<https://forms.gle/AZdV5rbhWKCEF3QE6>