

Device structures: monolithic

Eva Vilella

University of Liverpool

vilella@hep.ph.liv.ac.uk

HV-CMOS R&D Group at Liverpool

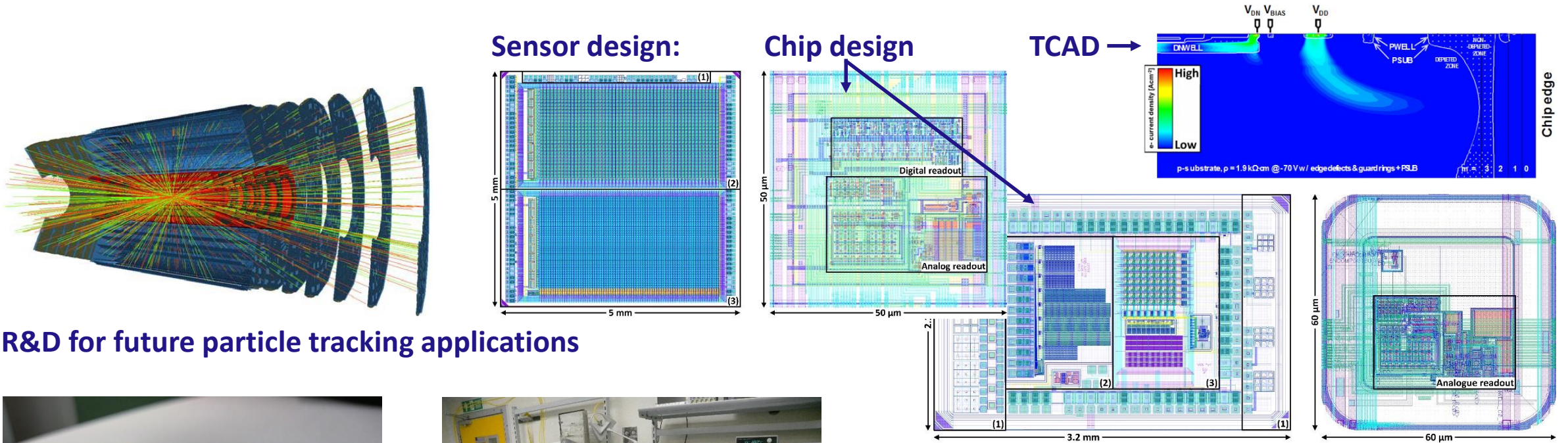

R&D for future particle tracking applications

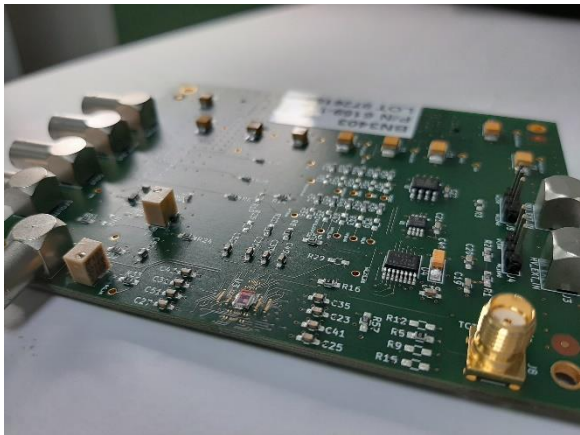

DAQ development



Experimental evaluation

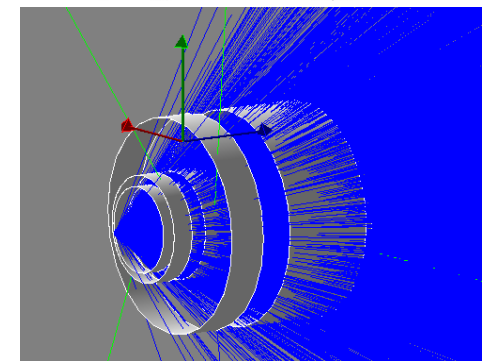
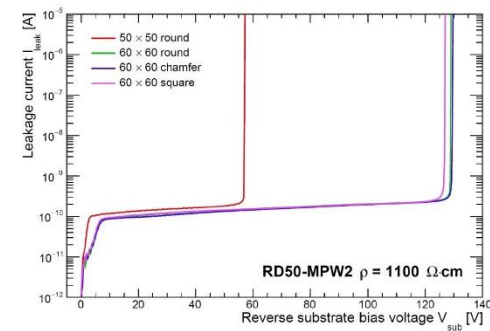

Geant4 simulations

Device structures: monolithic

- Monolithic refers to detectors that integrate the sensing element and readout chip in a single layer of silicon:
 - CMOS
 - HV-CMOS
- Both CMOS and HV-CMOS are the industry standard fabrication processes for MOSFET transistors used in integrated circuits (IC) chips:
 - CMOS (Low Voltage)
 - Image sensors
 - Microprocessors
 - Microcontrollers
 - Memories
 - Transceivers for communication
 - HV-CMOS = CMOS + High Voltage substrate biasing & additional wells to isolate the electronics from the substrate
 - Display and motor drivers

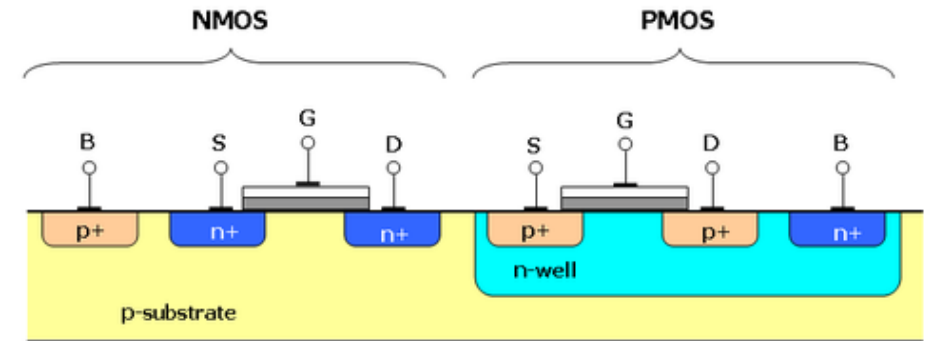

Wikipedia

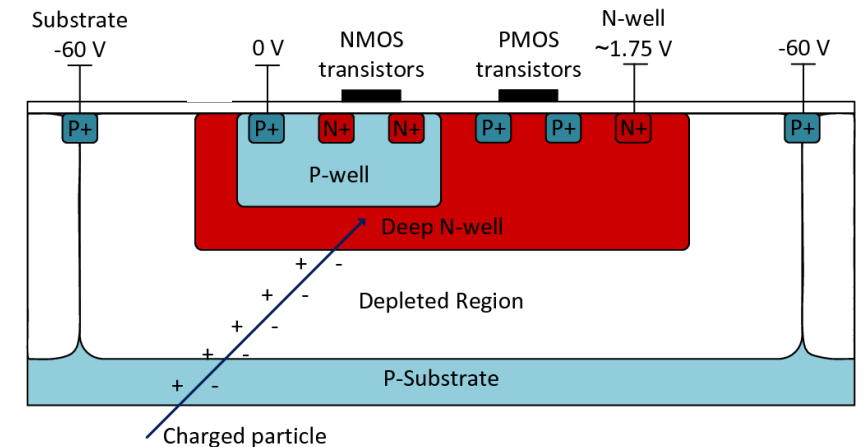

I. Kremastiotis, arXiv:1706.04470v2, 2017

Device structures: monolithic

- Can we use CMOS and HV-CMOS processes to fabricate detectors for physics experiments?
 - Absolutely yes!!!**

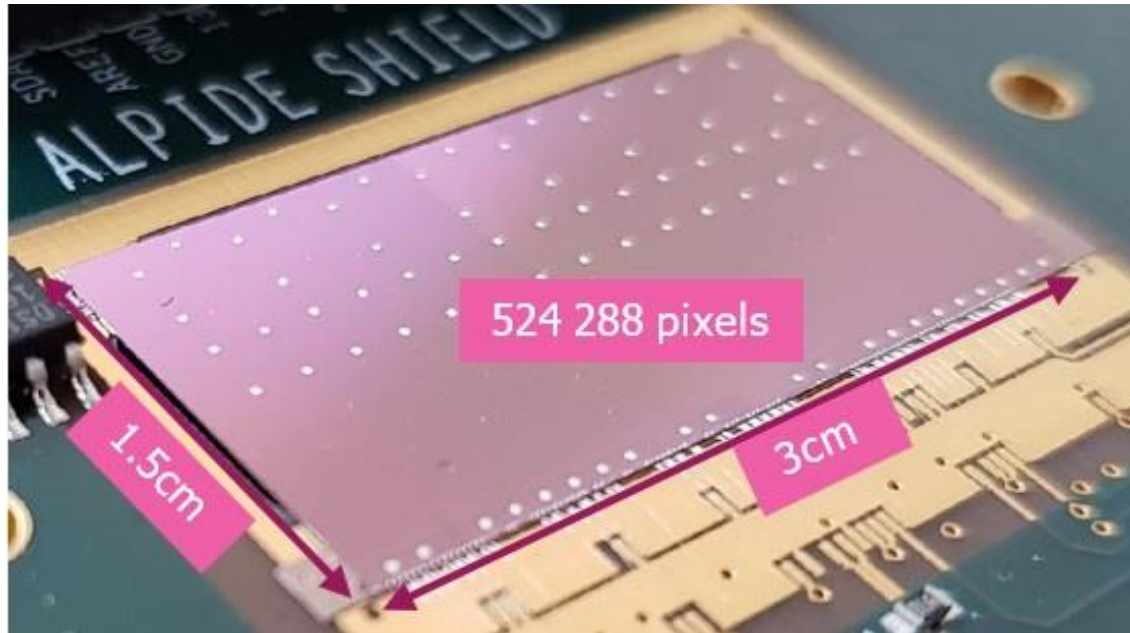

M. Mager, NIM-A: 824 434-438, 2016

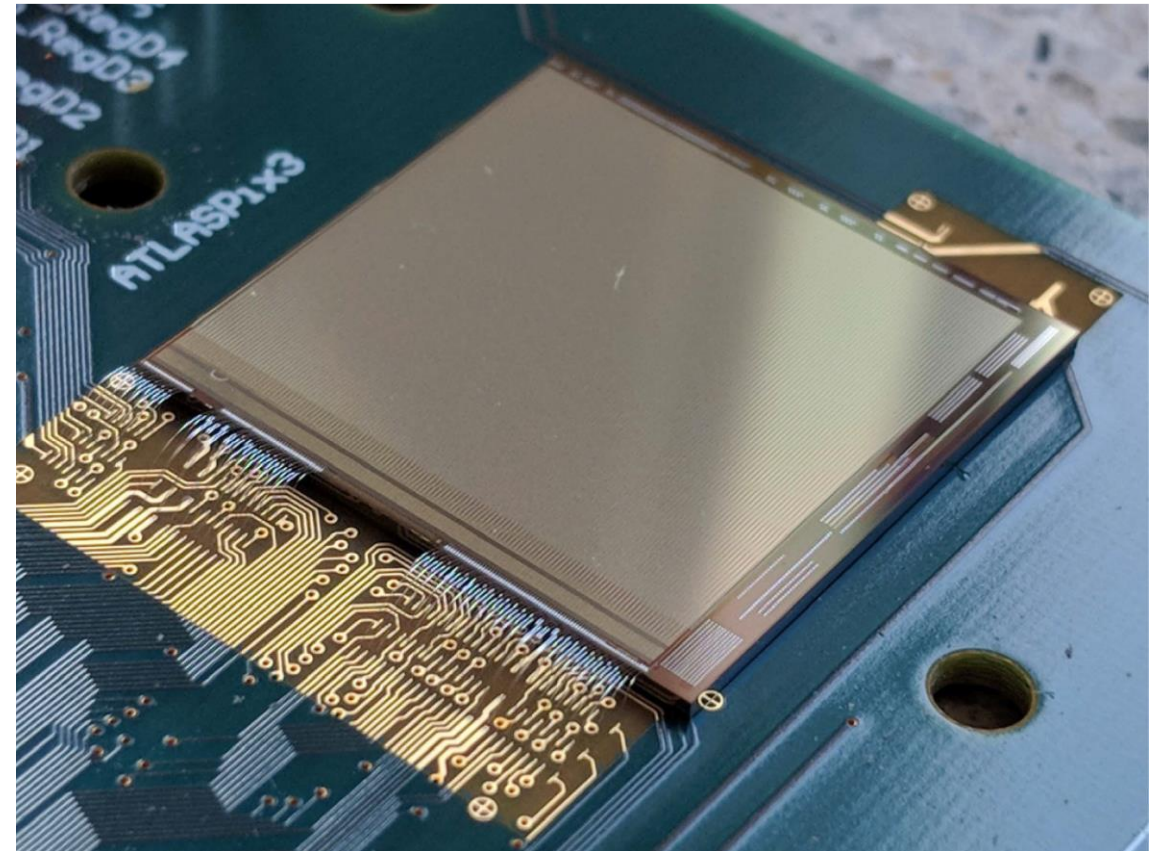

I. Peric, [10.1109/JSSC.2021.3061760](https://doi.org/10.1109/JSSC.2021.3061760), 2021

Particle tracking

Follow the tracks of an animal and identify it from its footprint

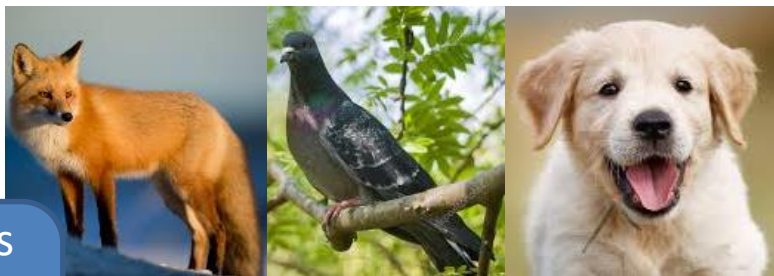

Monolithic devices have applications also in calorimetry and timing

Measure particle trajectories from hits they leave in silicon detectors

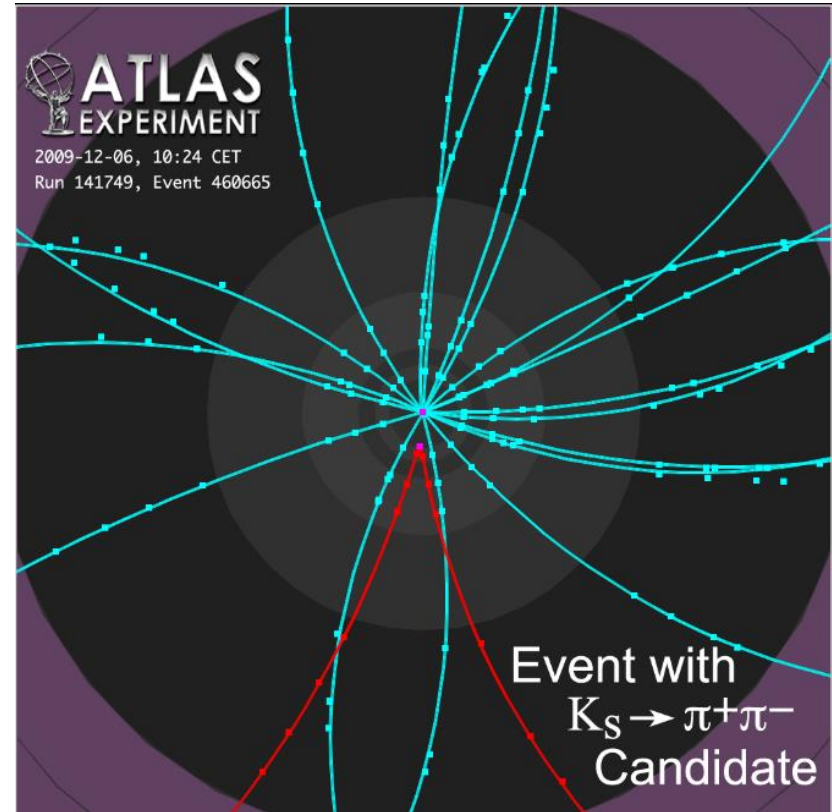

Connecting the dots: The **tracks** provide crucial information on a particle's direction, charge and energy.

The technological challenge

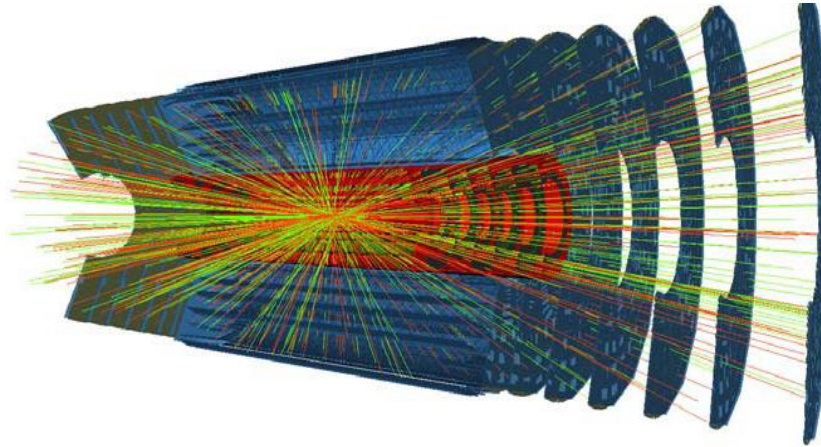

Billions of collisions per second produce 100's of billions of particles. Above picture shows one 25 ns frame with 1000s of particles.

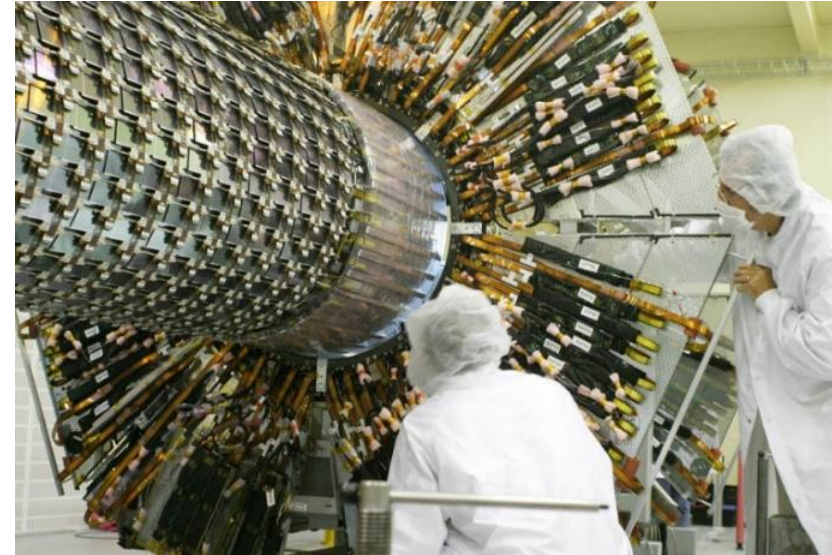

Detectors: Layers of thin silicon sensors measure accurate **hit points** along the particles' trajectories.

- Physics experiments require ever more precise and fast detectors to make high precision measurements in high intensity environments.
- Radiation tolerance is critical as detectors have to survive many years of operation.

Silicon tracking detectors – Specifications

Pixel size	Small	$\sim \mu\text{m} \times \mu\text{m}$
Time resolution	Excellent	$< 100 \text{ ps}$
Radiation tolerance	High	$> 10^{17} \text{ 1 MeV n}_{\text{eq}}/\text{cm}^2$
Material budget	Minimal	$< 50 \mu\text{m}$
Power consumption	Minimal	$\sim 10\text{-}100 \text{ mW}/\text{cm}^2$
Reticle size	Large	$> 2 \text{ cm} \times 2 \text{ cm}$
Noise	Minimal	
Assembly process	As easy as possible	
Yield	High	
Price	Cheap	

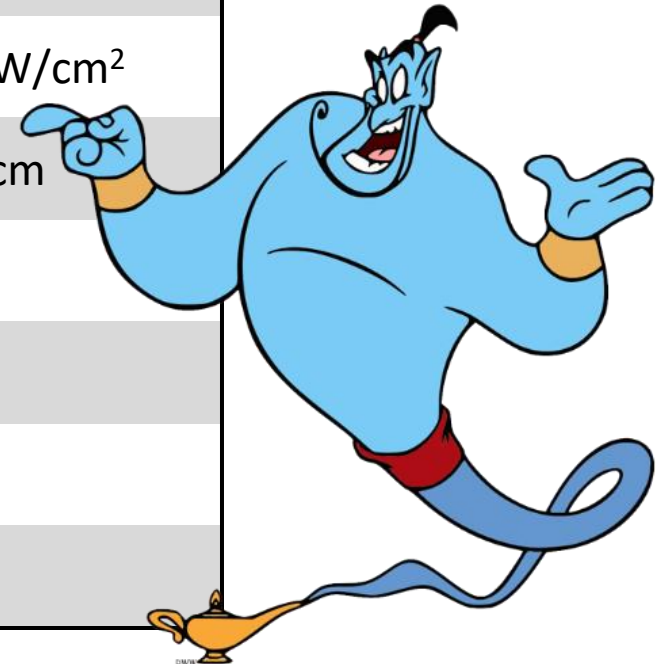

Sensor – Detection principle

- Silicon p-n diode in reverse bias
- A traversing particle creates e^-/h^+ pairs by ionization
- The electric field separates the e^-/h^+ pairs, which move to the detector electrodes where they generate signal
- Basic requirements:

- **Large bias voltage (V_{bias})**

- Larger $W \rightarrow$ larger signal
- Faster charge collection
- Better radiation tolerance

- **High resistivity silicon bulk (ρ)**

- **Backside biasing**

- More uniform electric field lines
- Improved charge collection efficiency

$$\rightarrow W = \sqrt{\rho \cdot V_{bias}}$$

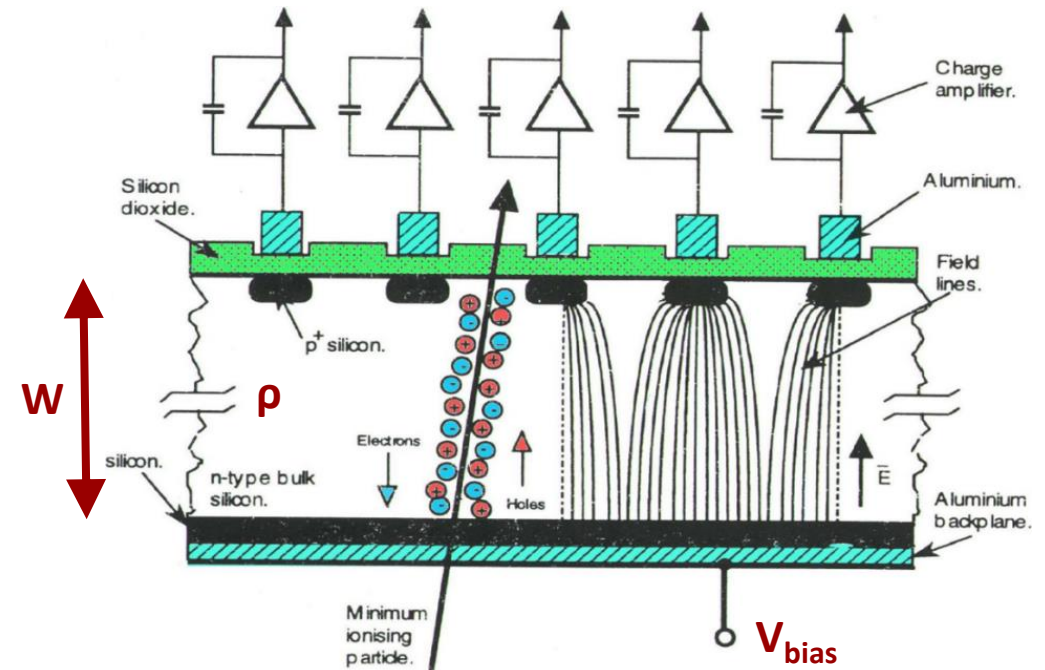

On average 80 electron-hole-pairs/ μm of depleted region for a MIP

- The signal is amplified, discriminated and digitized by the readout electronics

Readout electronics – The integrated circuit

FE-I3 – ATLAS pixel readout chip

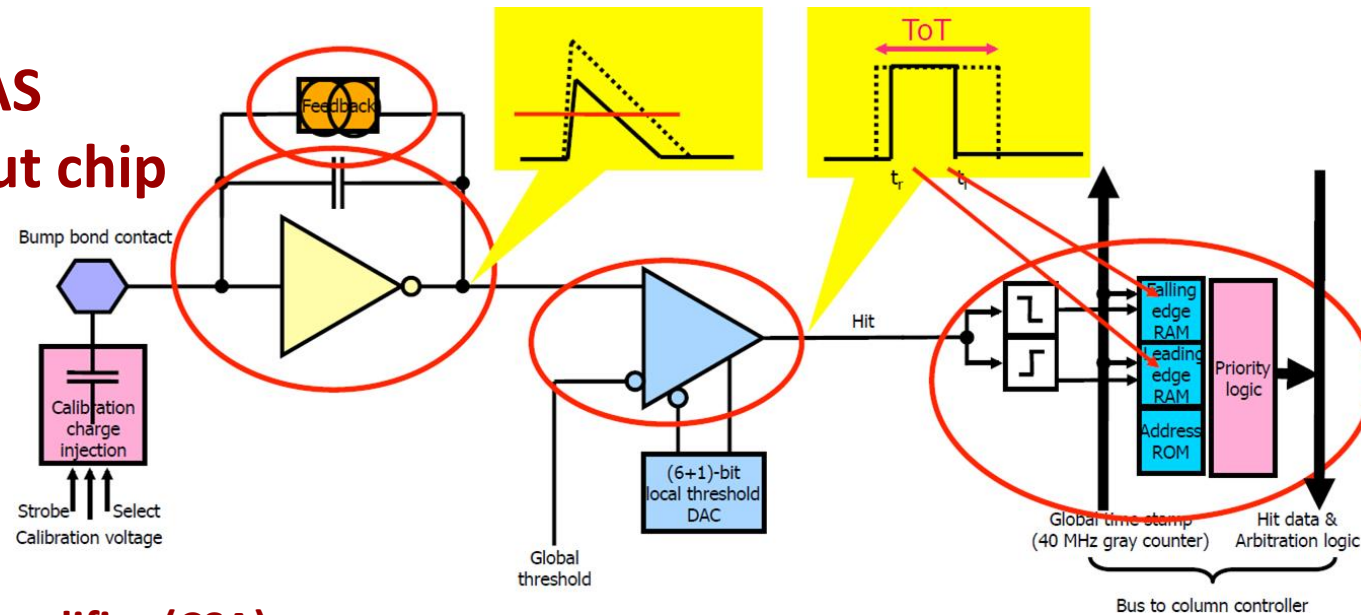

- **Charge Sensitive Amplifier (CSA)**
 - Signal charge integration
 - Pulse shaping (feedback capacitor with constant current)
- **Comparator with DAC for local threshold voltage compensation**
 - Pulse digitization
 - Length of digital pulse determined by time at which the rising and falling edges cross the comparator threshold voltage (Time over Threshold or ToT)
- **RAM and ROM memories** to store time-stamps and pixel address
- In deep sub-micron technologies for high density of integration

Hybrid pixel detectors

- Sensor and readout electronics on separate wafers
- **Best technology for the sensor and the readout electronics**
 - Very fast charge collection by drift (1 ns)
 - Fully depleted bulk (large signal)
 - Radiation tolerant (10^{16} 1MeV n_{eq}/cm^2)
 - Capability to cope with high data rates
- **1-to-1 connection between sensor and readout chip via tiny conductive bumps using bumping and flip-chip technology**
 - Limited pixel size ($55\ \mu\text{m} \times 55\ \mu\text{m}$)
 - Substantial material thickness ($300\ \mu\text{m}$)
 - Limited fabrication rate (bump-bonding and flip chipping is complex)
 - Expensive ($> \text{£}1\text{M}/\text{m}^2$) – custom wafers and processing
- **State-of-the-art for high rate experiments**

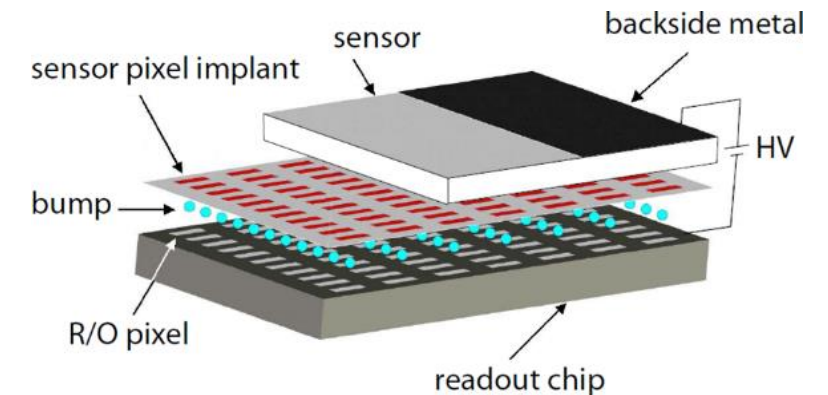
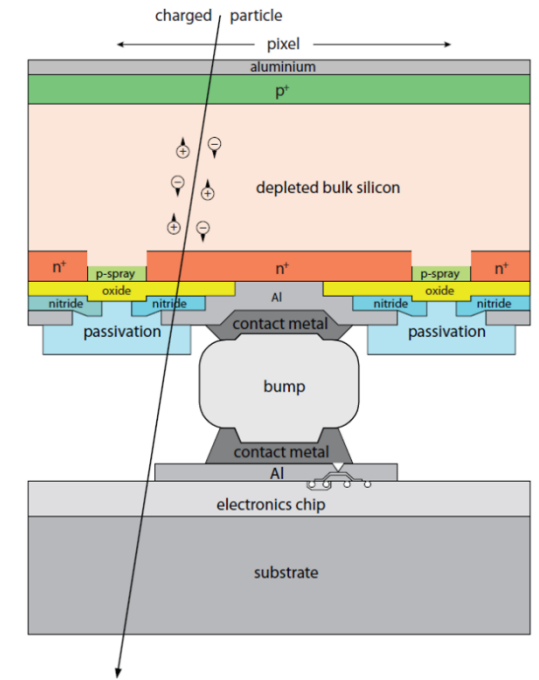

M. Garcia-Sciveres, arXiv:1705.10150v3, 2018

Hybrid pixel detectors in particle physics

- **ATLAS, CMS and ALICE** use hybrid pixel detectors near the interaction point
- Complemented by hybrid strip detectors at larger radii
- Largest detector systems ever built in HEP (several m²)

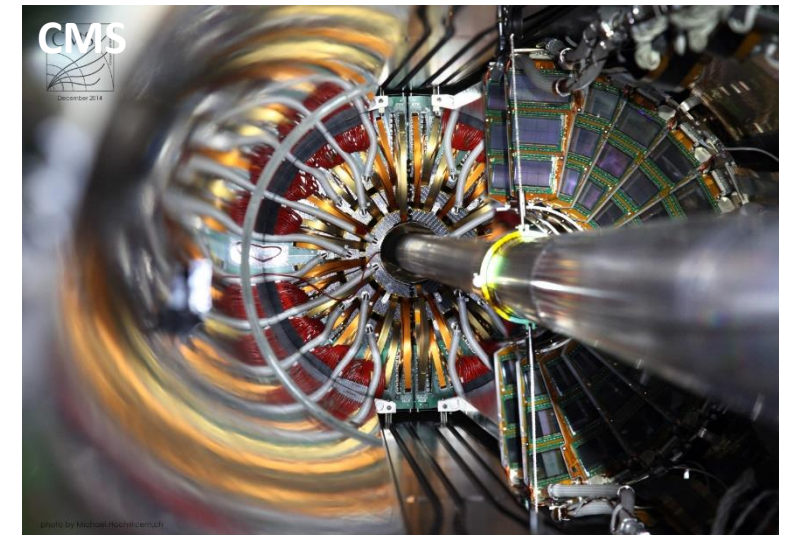
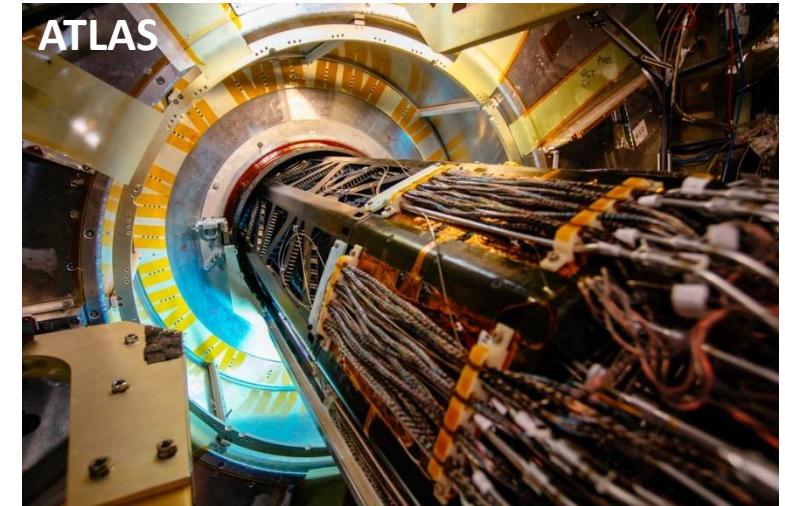

CMOS/HV-CMOS technology applications



CMOS/HV-CMOS technology

- Why is it so popular?
 - Reliable (industry-standard)
 - Low-power consumption
 - Low-cost
 - Scalable (millions of transistors are integrated into a single chip)
 - Starting material is silicon (sand)

Moore's law (1965) → The number of transistors in a dense integrated circuit (IC) doubles about every two years

Moore's Law – The number of transistors on integrated circuit chips (1971-2018)
 Moore's law describes the empirical regularity that the number of transistors on integrated circuits doubles approximately every two years. This advancement is important as other aspects of technological progress – such as processing speed or the price of electronic products – are linked to Moore's law.

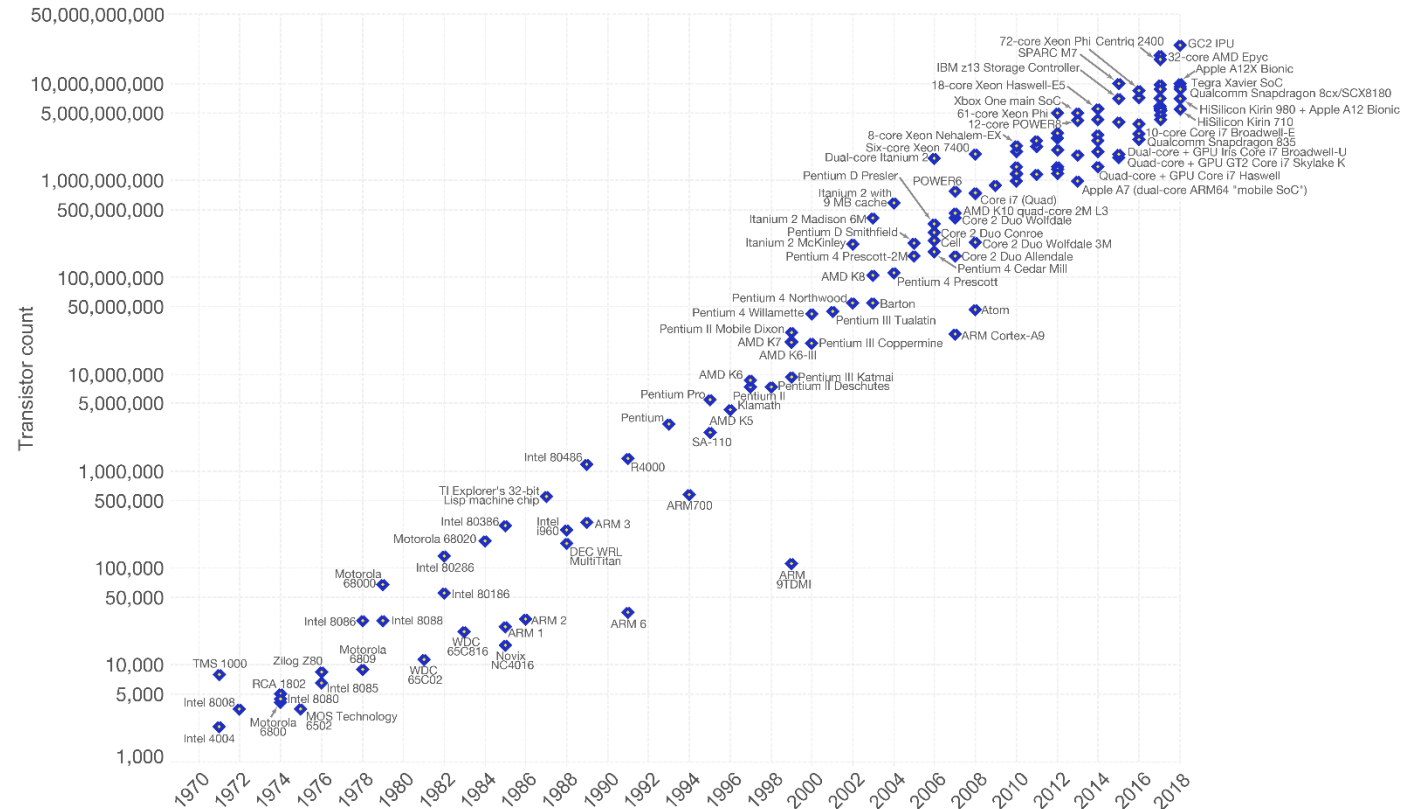

Data source: Wikipedia (https://en.wikipedia.org/wiki/Transistor_count)
 The data visualization is available at OurWorldinData.org. There you find more visualizations and research on this topic.

Licensed under CC-BY-SA by the author Max Roser.

CMOS/HV-CMOS commercial vendors



ON Semiconductor®

CMOS/HV-CMOS commercial vendors

Foundry → Parameter ↓			
Feature node	150 nm	180 nm	180 nm
HV	Yes	No	Yes
HR	Yes	Yes	Yes
Quadruple well	Yes	Yes	Yes
Metal layers	6	6	6
Backside processing	Yes	Yes	No
Stitching	Yes	Yes	Yes

And since very recently also TPSCo 65 nm

Monolithic pixel detectors

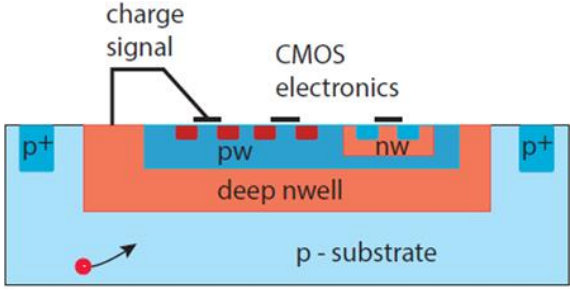
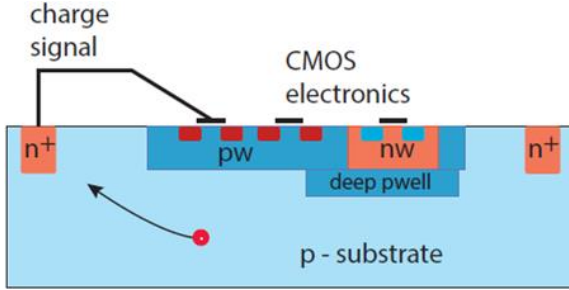
<p>Sensor cross-section →</p> <p>Parameter ↓</p>		
<p>Name</p>	<p>Large fill-factor (HV/HR-CMOS)</p>	<p>Small fill-factor (HR-CMOS)</p>
<p>1) p/n junction</p>	<p>p-substrate/large deep n-well (RO in charge collection well)</p>	<p>p-substrate/small shallow n-well (RO outside charge collection well)</p>
<p>2) Substrate biasing</p>	<p>High voltage</p>	<p>Low voltage</p>
<p>3) Substrate resistivity</p>	<p>< 2-3 kΩ·cm</p>	<p>< 8 kΩ·cm</p>
<p>1) + 2) + 3)</p>	<ul style="list-style-type: none"> ▪ Large pixel capacity ▪ Higher noise ▪ Higher power consumption ▪ Short drift distances ▪ High radiation tolerance ▪ Good timing resolution 	<ul style="list-style-type: none"> ▪ Small pixel capacity ▪ Lower noise ▪ Low power consumption ▪ Long drift distances ▪ Less radiation tolerance ▪ Worse timing resolution
<p>Process</p>	<p>AMS/TSI 180 nm + LFoundry 150 nm</p>	<p>TowerJazz 180 nm</p>

Monolithic pixel detectors: first CMOS sensors

- Sensor and readout electronics on single wafer in standard CMOS (low-voltage CMOS)
 - Reduced material thickness (50 μm)
 - Small pixel size (18 μm x 18 μm)
 - In-pixel signal amplification
 - More cost effective ($\sim\text{£}100\text{k}/\text{m}^2$)
 - Small bias voltage (V_{bias})
 - Slow charge collection by diffusion (2 μs)
 - Limited radiation tolerance (10^{13} 1MeV $n_{\text{eq}}/\text{cm}^2$)

- **State-of-the-art for high precision experiments**

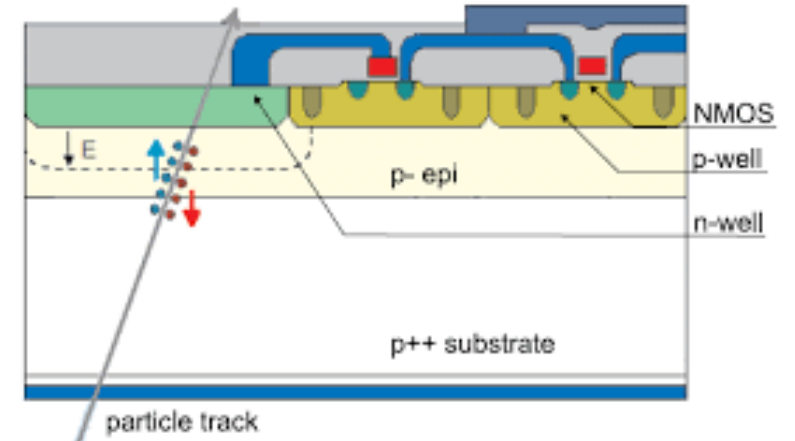

Improved values recently

CMOS detectors in particle physics – STAR experiment

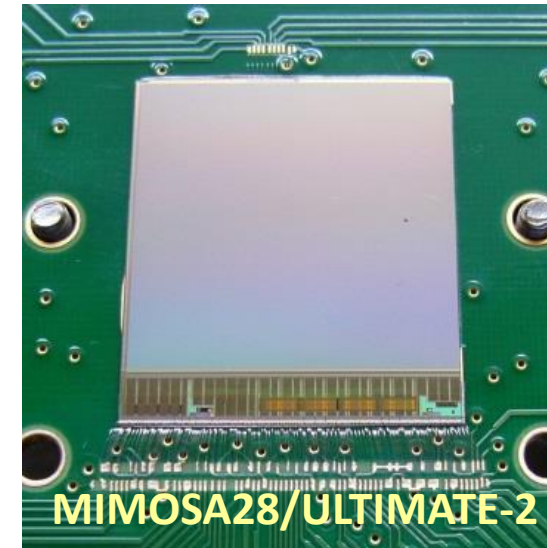
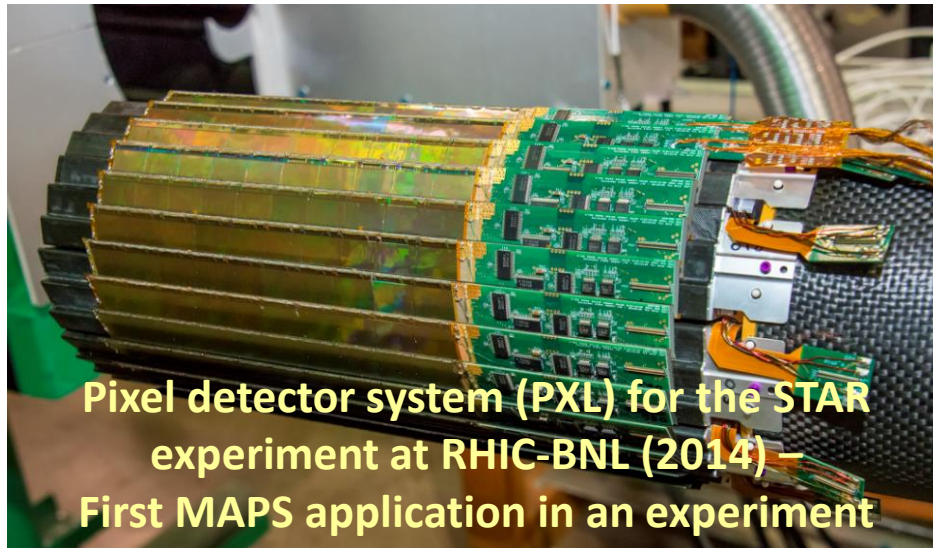

G. Contin, arXiv:1710.02176v2, 2018

■ MIMOSA-28 / ULTIMATE chip:

- Chip size 20 mm x 22 mm
- Total detector area 0.15 m²
- Sensor matrix 928 x 960 pixels (~0.9 Mpixels per chip); 400 pixel chips in total ~360 Mpixels
- Pixel size 20.7 μm x 20.7 μm (MAPS chosen to improve hit resolution to enable the reconstruction of hadronic decays of heavy flavour mesons and baryons)
- Radiation tolerance 150 krad (TID) + 10¹² 1 MeV n_{eq}/cm² (NIEL)
- Process AMS 0.35 μm OPTO

CMOS detectors in particle physics – ALICE ITS upgrade

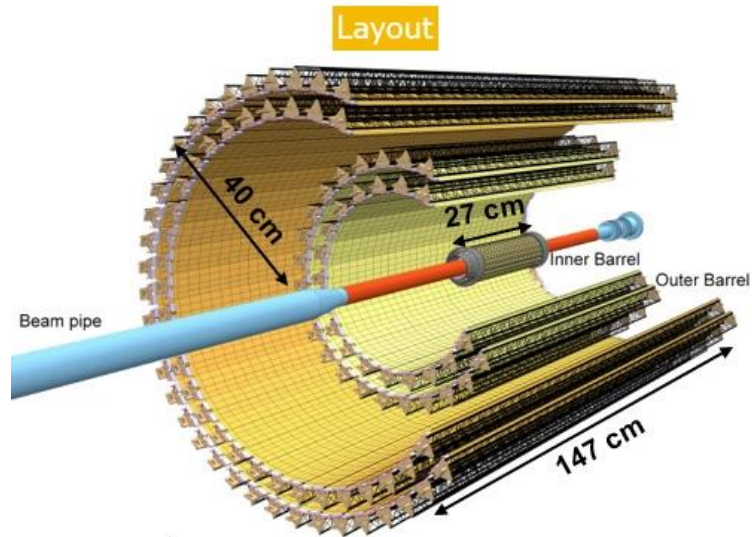

ALICE ITS upgrade ITS2 (2020)

Sensor requirements

Parameter	IB	OB
Sensor thickness (μm)	50	50
Spatial resolution (μm)	5	10
Dimensions (mm^2)	15×30	15×30
Power density (mW cm^{-2})	300	100
Time resolution (μs)	30	30
Detection efficiency (%)	99	99
Fake hit rate ^a	10^{-5}	10^{-5}
TID radiation hardness ^b (krad)	2700	100
NIEL radiation hardness ^b ($1 \text{ MeV } n_{\text{eq}}/\text{cm}^2$)	1.7×10^{13}	10^{12}

M. Mager, doi.org/10.1016/j.nima.2015.09.057, 2016

CMOS detectors in particle physics – ALICE ITS upgrade

Layout

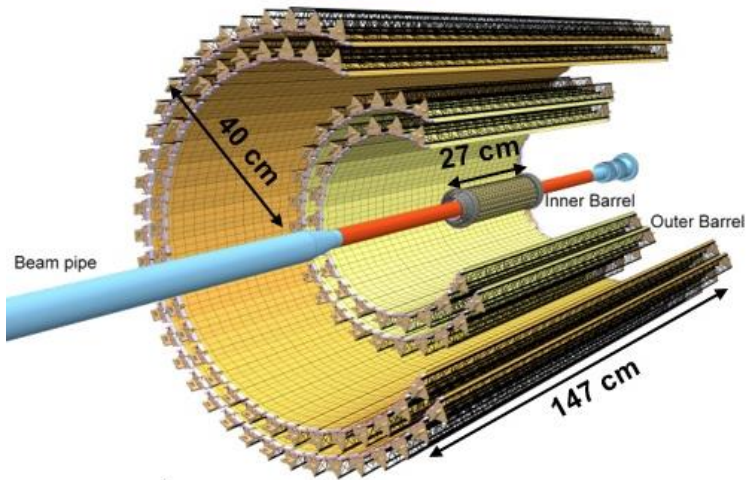

M. Mager, NIM-A: 824 434-438, 2016

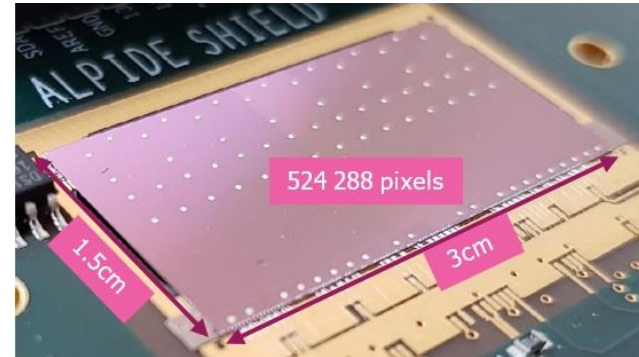

ALPIDE

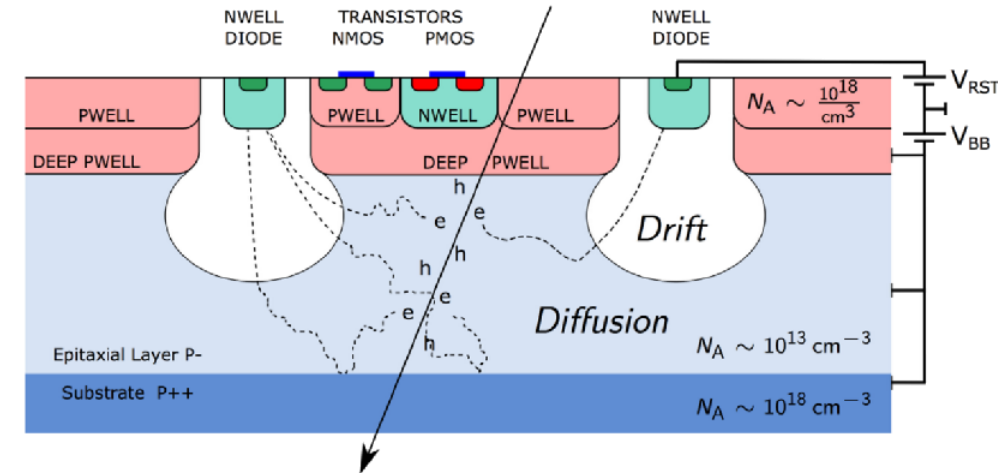

ALICE ITS upgrade ITS2 (2020)

ALPIDE chip:

- Chip size 15 mm x 30 mm
- Total detector area 10 m²
- Sensor matrix 1024 x 512 pixels (> 0.5 Mpixels); 24k pixel chips in total ~12.5 Gpixels
- Pixel size 26 μm x 29 μm
- Radiation tolerance 700 krad (TID)
- 10¹³ 1 MeV n_{eq}/cm² (NIEL)
- Process TowerJazz 180 nm

CMOS detectors – Modified and improved TowerJazz

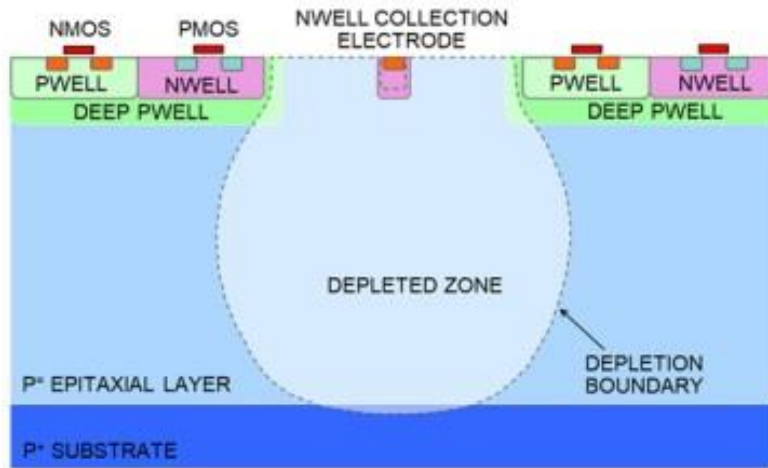

(a)

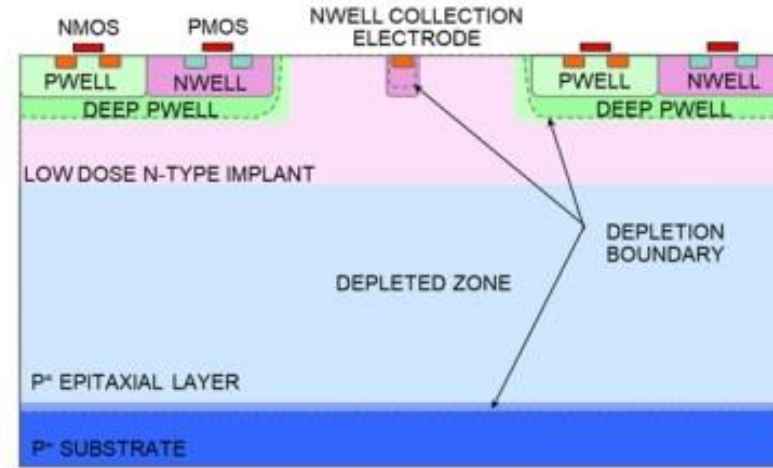

(b)

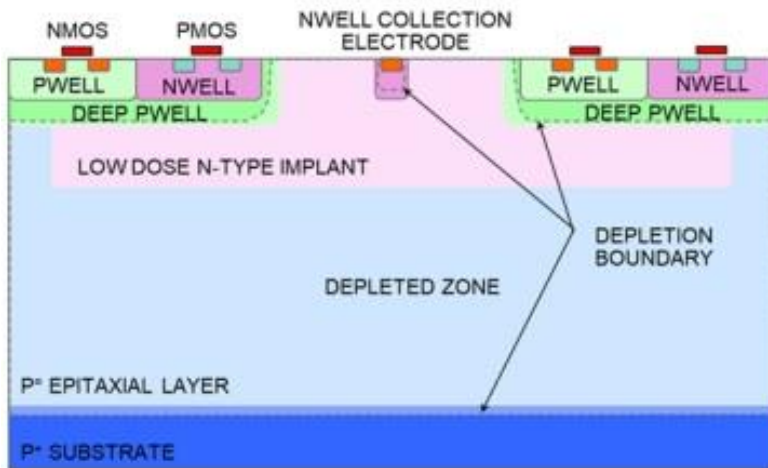

(c)

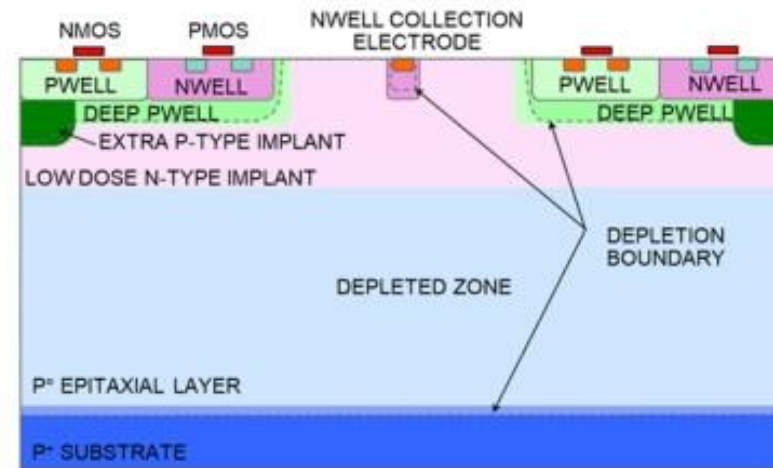

(d)

Process modifications to fully deplete the sensor and enhance the lateral electric field in the pixel corners for good tolerance to NIEL (Non-Ionising Energy Loss)

CMOS detectors – Modified and improved TowerJazz

Modified process

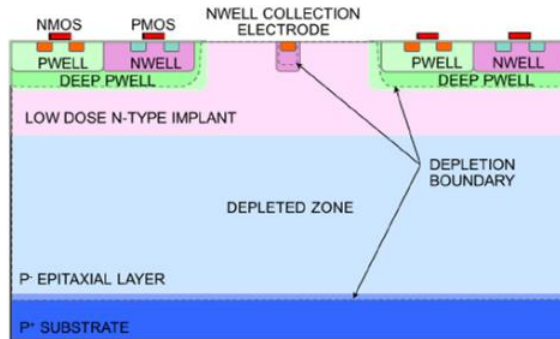

Extra deep p-well implant

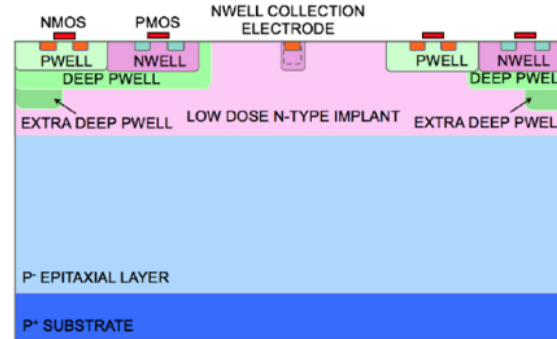

Gap in the n-layer

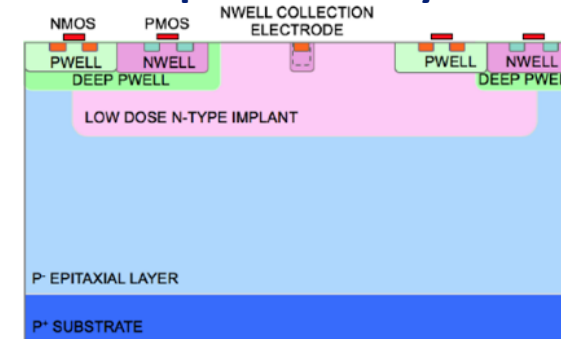

B. Hiti, 2018

Implemented in MALTA chips

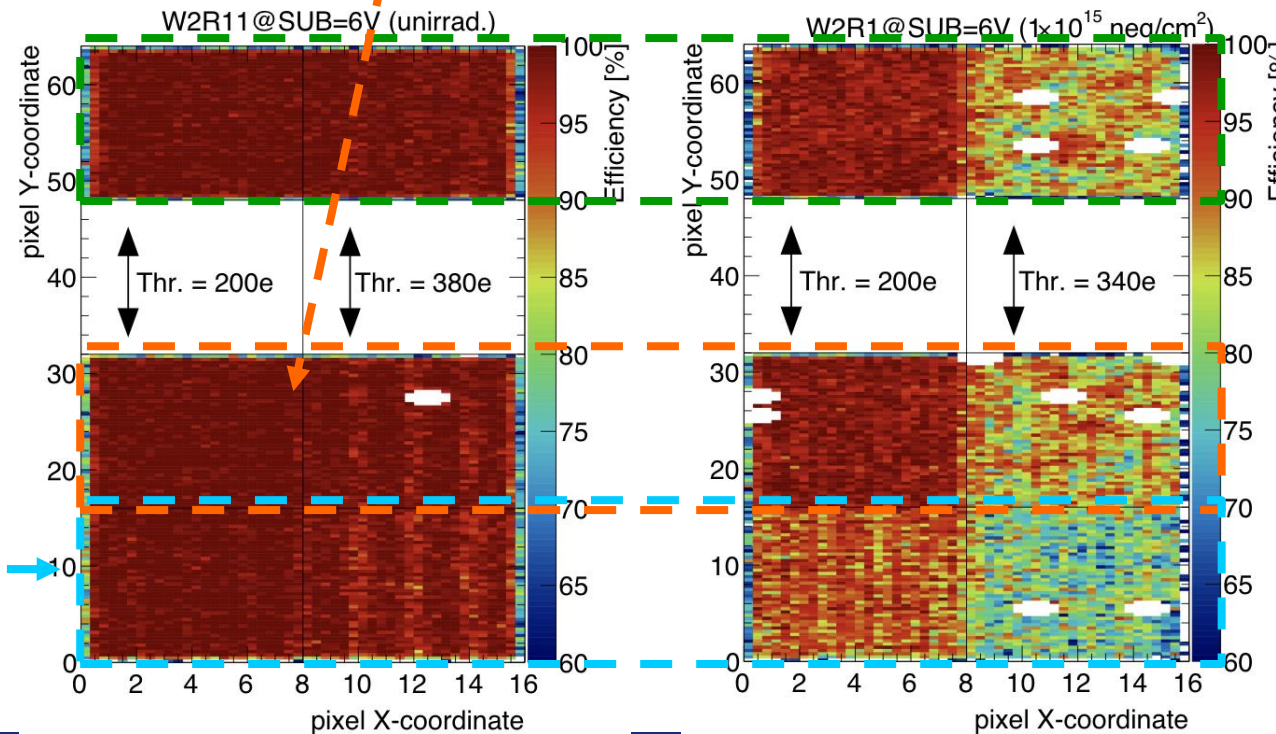

98-99% efficiency after $1 \times 10^{15} n_{eq}/cm^2$

Test beam at DESY and ELSA



MALTA2 (results from Pixel 2022)

<https://indico.cern.ch/event/829863/contributions/4479493/>

- Design team CERN, Bonn University, CPPM

chip	first available	size	front end	sensor type	sensor modification	note
MALTA2	Early 2021	2 x 1 cm	enlarged transistor / cascoded	epitaxial and Cz	standard, n-layer gap, deep p-well insert	fully functioning slow control

- Improved front end in MALTA2:
 - enlarged transistors for lower noise and higher gain

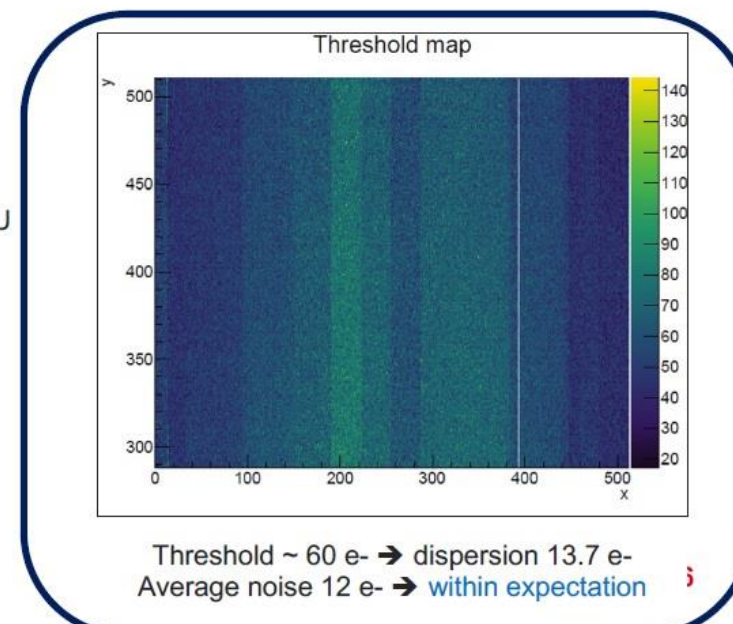
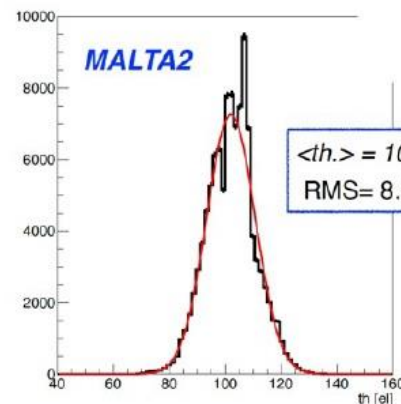
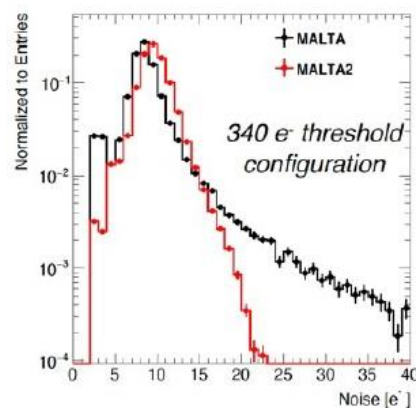

F. Guilloux, 2023



MALTA2 (results from Pixel 2022)

<https://indico.cern.ch/event/829863/contributions/4479493/>

Radiation tests (done by MALTA group)

- TID up to 100 Mrad
 - Room temperature
- NIEL up to $3 \cdot 10^{15} N_{eq} 1 \text{ MeV} / \text{cm}^2$
 - Cooled down to -20°C
 - SUB voltage : -50 V

Timing (done by MALTA group)

- $> 98\%$ of clusters collected within 25 ns

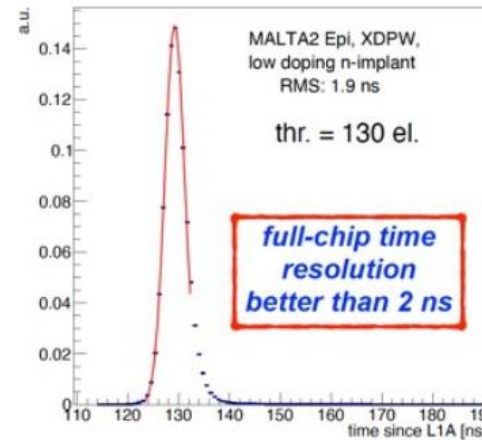
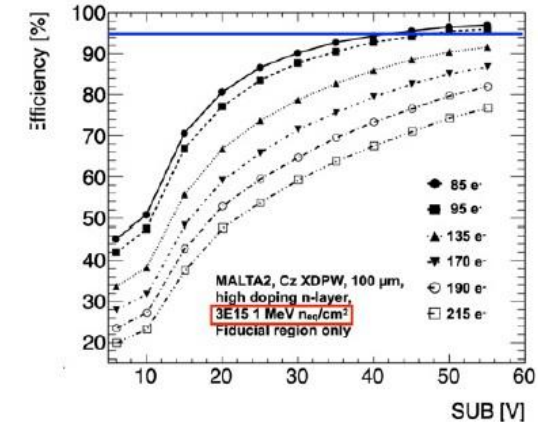
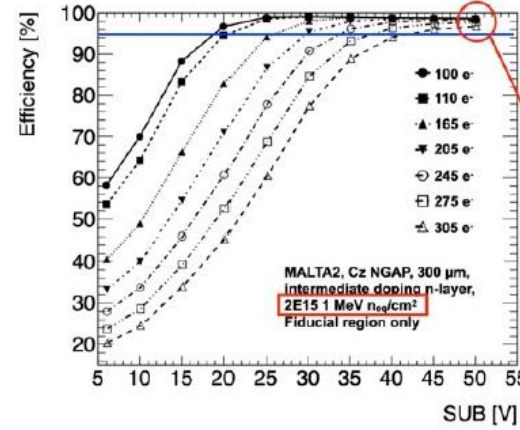

signals from the pixel center arrives ~2 ns earlier than signal in the corner

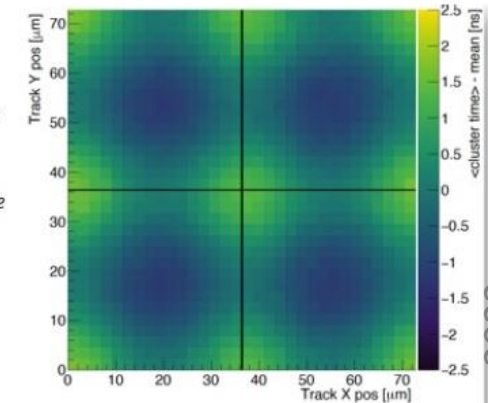



TPSCo 65nm

DPTS

- From CERN group (Walter S.)
- Test vehicle for digital asynchronous readout
- Working point ~ 99% efficiency at acceptable fake-hit rate

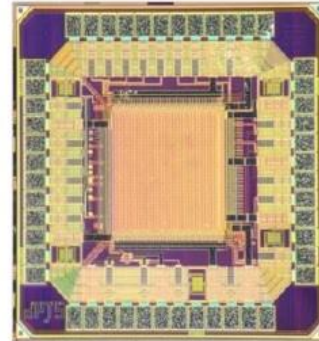

DPTS

32 X 32 pixels
15 μm pitch
Asynchronous digital readout
ToT information

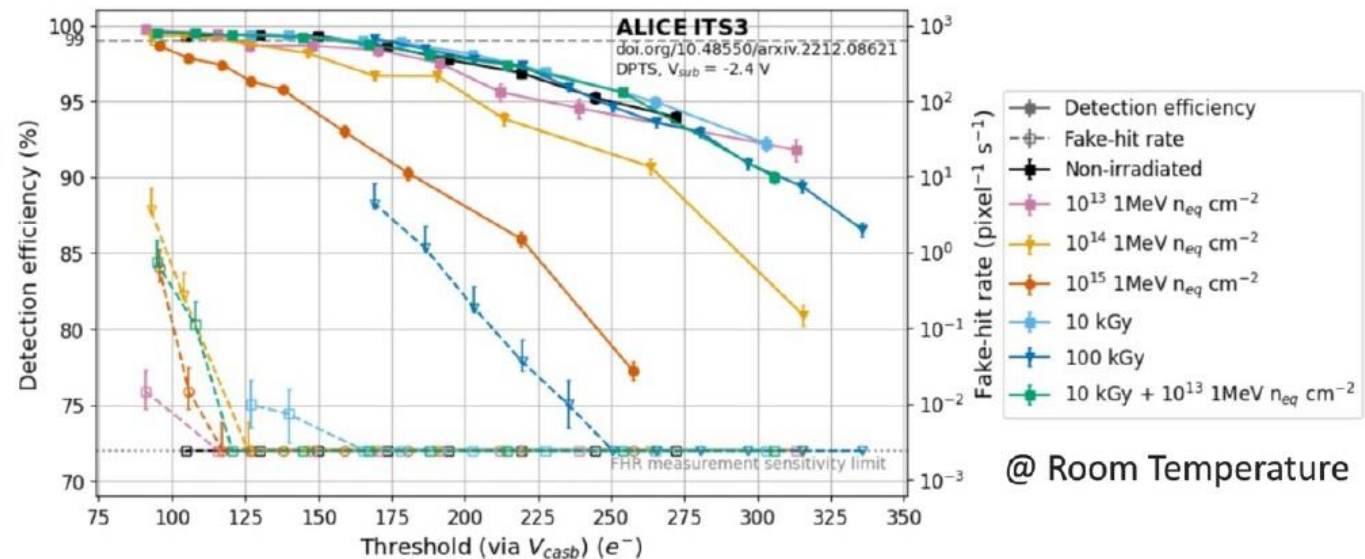

Monolithic pixel detectors: HV-CMOS

- Sensor and readout electronics on single wafer in standard High Resistivity/High Voltage-CMOS (HR/HV-CMOS)
 - Reduced material thickness (50 μm)
 - Small pixel size (50 μm x 50 μm)
 - In-pixel amplification
 - More cost effective ($\sim\text{£}100\text{k}/\text{m}^2$)
 - Larger bias voltage (V_{bias})
 - Fast charge collection by drift (~ 3 ns time resolution)
 - Good radiation tolerance (10^{15} 1MeV $n_{\text{eq}}/\text{cm}^2$)
 - One limitation: The chip size is in principle limited to 2 cm x 2 cm, although stitching options are being investigated
- **Next generation**

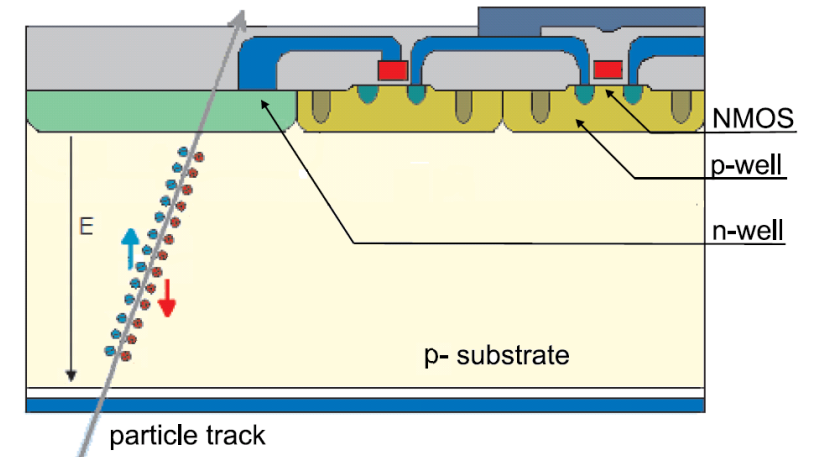

HV-CMOS applications in particle physics

■ Mu3e experiment at PSI in Switzerland

- To search for lepton flavour violating decays
- MuPix (HV-CMOS sensor chip, selected)
 - $\leq 50 \mu\text{m}$ thickness, minimum material
 - $80 \mu\text{m} \times 80 \mu\text{m}$ pixel size
 - $\leq 20 \text{ ns}$ time resolution
- Detector construction planned for 2023

■ Mighty Tracker upgrade at the LHCb experiment at CERN

- Major tracking detector system upgrade to cope with increased luminosity in coming runs
- MightyPix (HV-CMOS sensor chip, proposed)
 - $6E10^{14} \text{ 1 MeV } n_{\text{eq}}/\text{cm}^2$ radiation tolerance
 - $\leq 3 \text{ ns}$ time resolution
- To be installed during LS3 and LS4

■ Others: ATLAS ITk, CEPC, CERN-RD50...

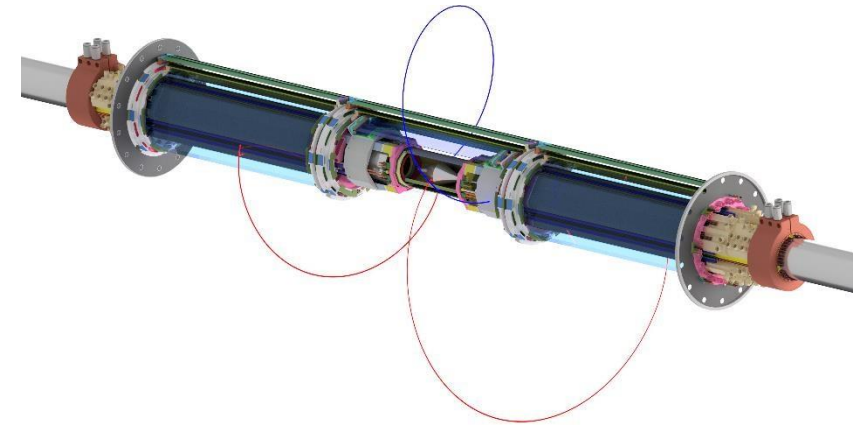

Mu3e

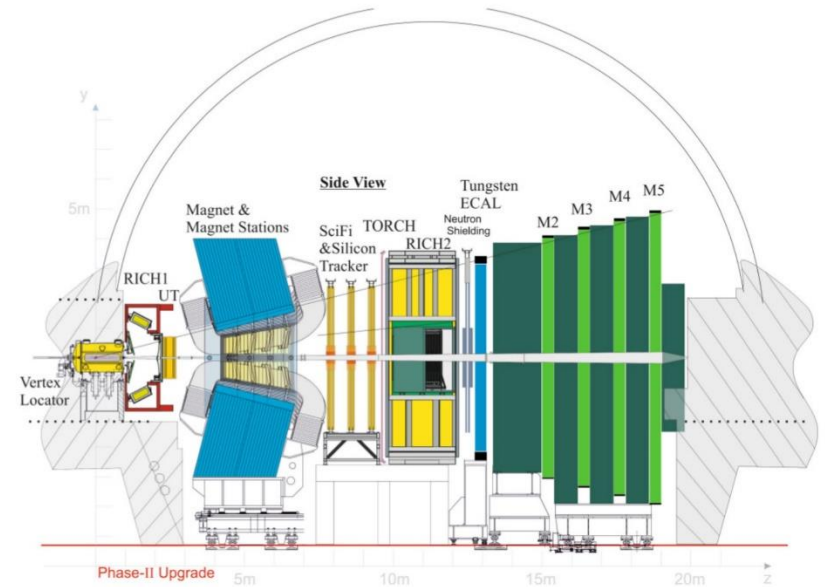

LHCb Upgrade II FTDR, 2022

HV-CMOS detectors in particle physics – Mu3e

Prototype	Year	Active area (mm ²)	Functionality	Main features
MuPix1	2011	1.77	Sensor + analog RO	First MuPix prototype
MuPix2	2011	1.77	Sensor + analog RO	
MuPix3	2012	9.42	Sensor + analog/digital RO	First digital RO
MuPix4	2013	9.42	Sensor + analog/digital RO	Working digital RO and time-stamping
MuPix6	2013	10.55	Sensor + analog/digital RO	
MuPix7	2014	10.55	SoC (all relevant features for a fully monolithic chip)	First MuPix with SM, clock generation and fast serial RO (1.25 Gbit/s)
MuPix8	2017	160	Large SoC	First large MuPix prototype, with TW correction
MuPix9	2018		SoC	Voltage regulators
MuPix10	2019	400	Full size (reticle) SoC	First full size SoC
MuPix11	2022		Full size (reticle) SoC	Fixes bugs of MuPix10

MuPix10 – Main details

- Fully monolithic sensor in the 180 nm HV-CMOS TSI process
- Active pixel matrix size of 20 mm x 20 mm (256 x 250 pixels)
 - Chip split into 3 sub-matrices with 84, 86 and 86 columns
- Pixel size is 80 μm x 80 μm
- Hits are read out using the column-drain architecture
 - Two time-stamps are stored for each hit (rising and falling edges)
- 8b10b encoding
- Hits are sent over up to four serial links with nominal 1.25 Gbit/s
 - One link per sub-matrix + an additional fourth to send combined data
 - Max. hit rate of 90 Mhit/s can be achieved, theoretically
- On-chip biasing to minimise electrical connections
- Measured $V_{BD} = 100\text{ V}$, 200 $\Omega\cdot\text{cm}$ substrate resistivity $\rightarrow W_D = 40\ \mu\text{m}$
 - No inactive bulk for 50 μm thin sensors
- Measured power consumption = 190 mW/cm²

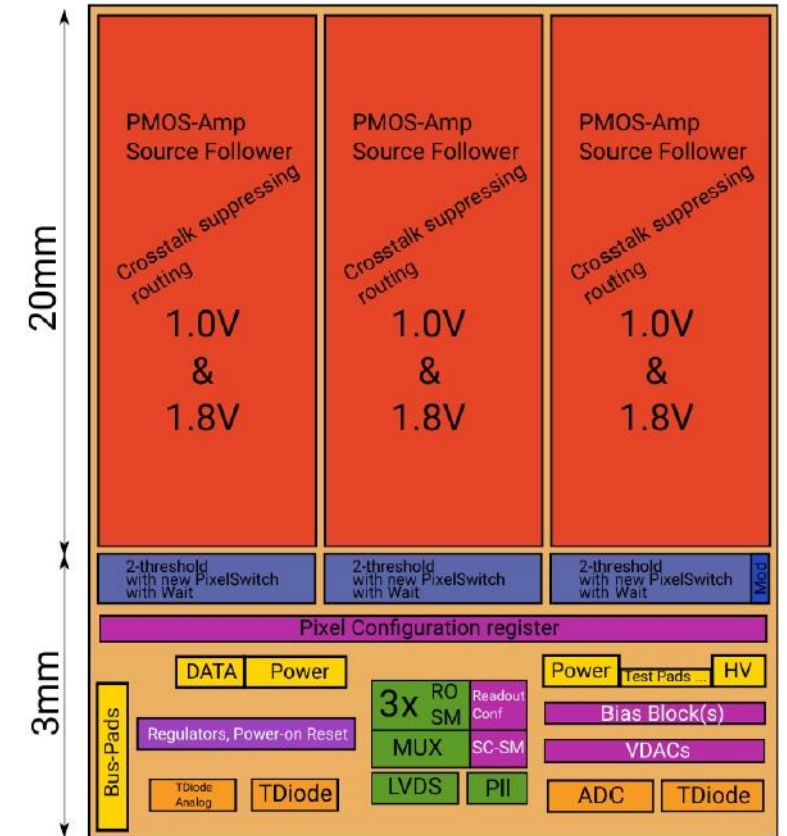

H. Augustin, Tracking Verbund Meeting, 2021

MuPix – Functional diagram

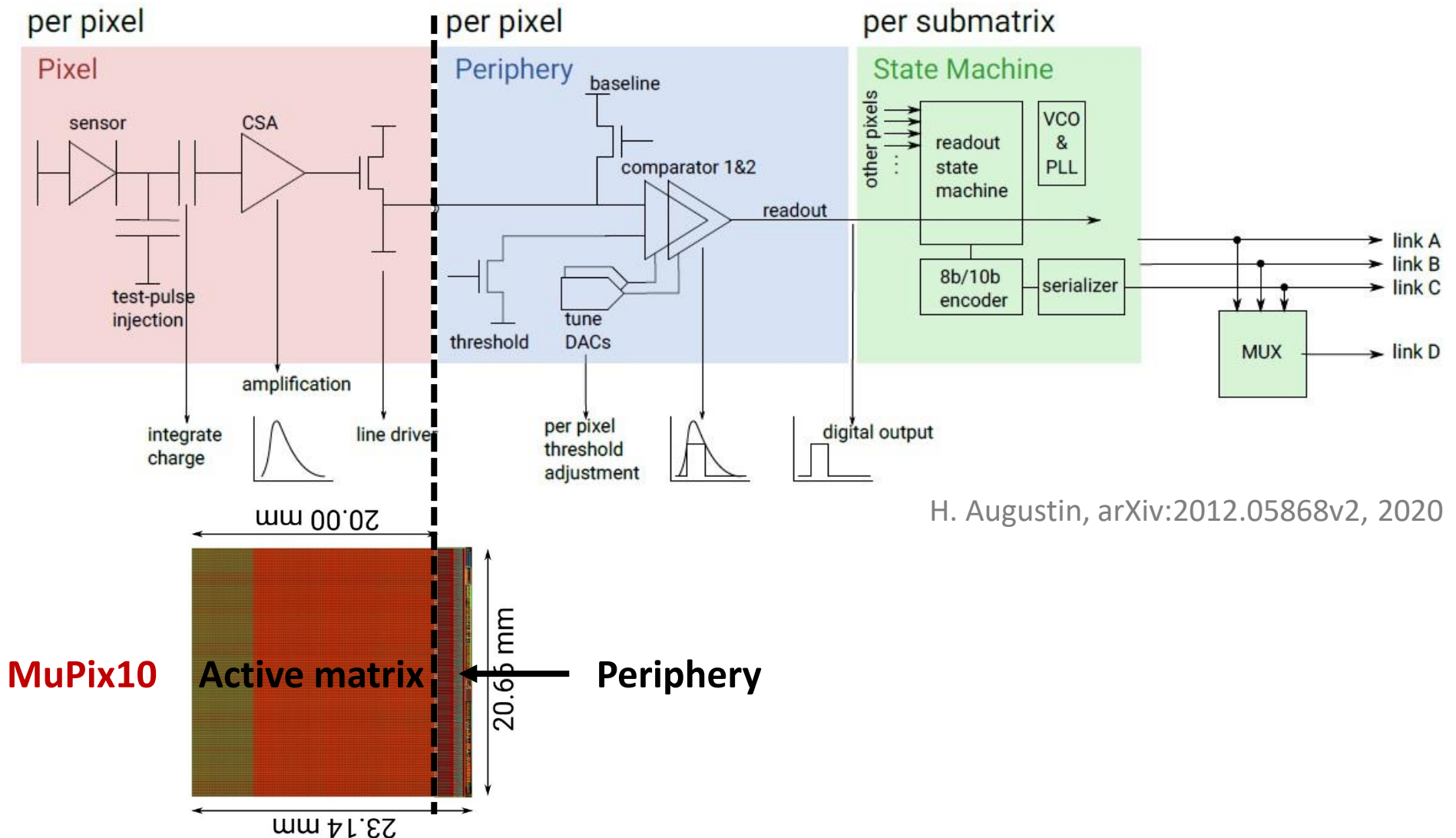

H. Augustin, arXiv:2012.05868v2, 2020

Time-Walk (TW) – What is it & ways to improve it

Time-Walk (TW)

- What is it? Variation of the response time of the readout electronics depending on the number of e^-/h^+ pairs collected by the sensor

TW correction – Two-threshold method

- Two comparators with two threshold voltages:
 - V_{TH1} is very low (close to the noise level) → it delivers a time-stamp with small TW
 - $V_{TH2} > V_{TH1}$ → it confirms that the flagged time-stamp corresponds to a real signal and not to noise
- Measured results show the TW can be reduced to ~ 3 ns

TW correction – Other methods

- Increasing the response rate of the amplifier (CACTUS, RD50-MPW2)
- Time-walk compensated comparator (HVStripV1, H35DEMO)
- Sampling method (LF-ATLASPix, CERN-RD50)

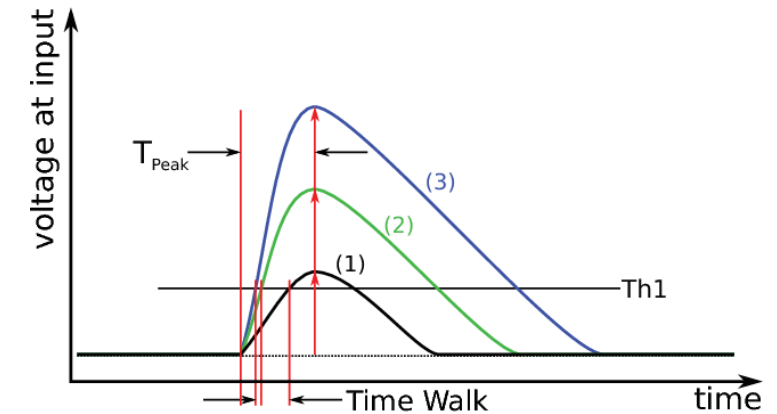

R. Schimassek, IEEE NSS/MIC/RTSD, 2016

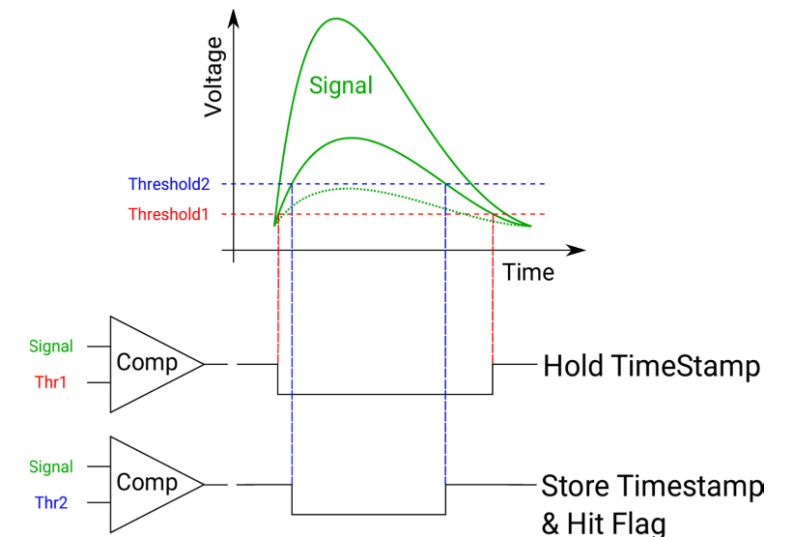

H. Augustin, PoS (VERTEX2017) 057

Other functional diagrams are possible

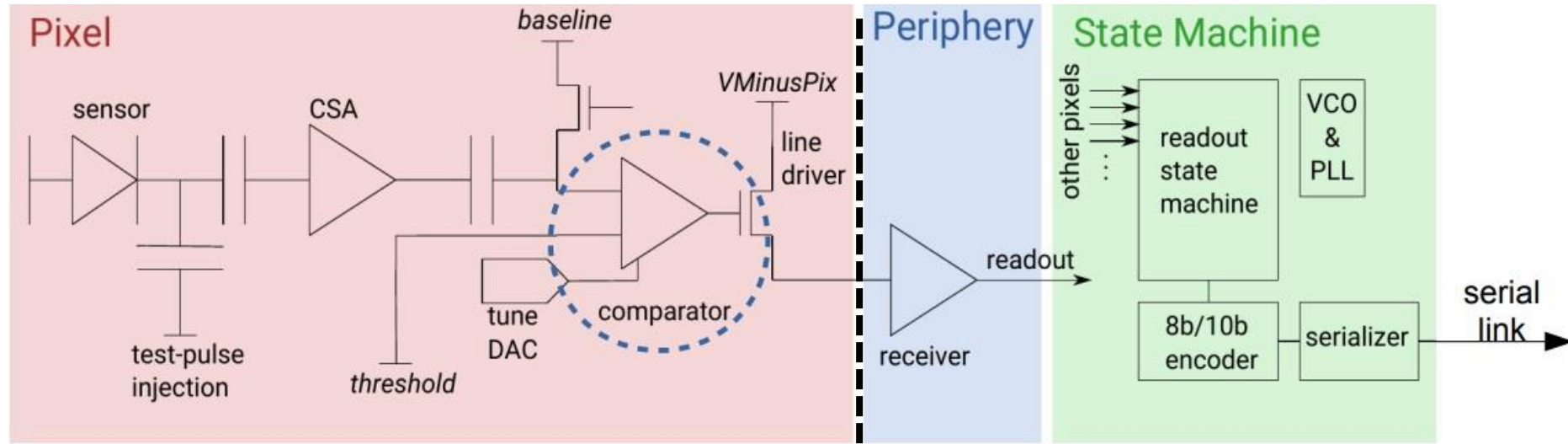

A. Schoening, VERTEX2019

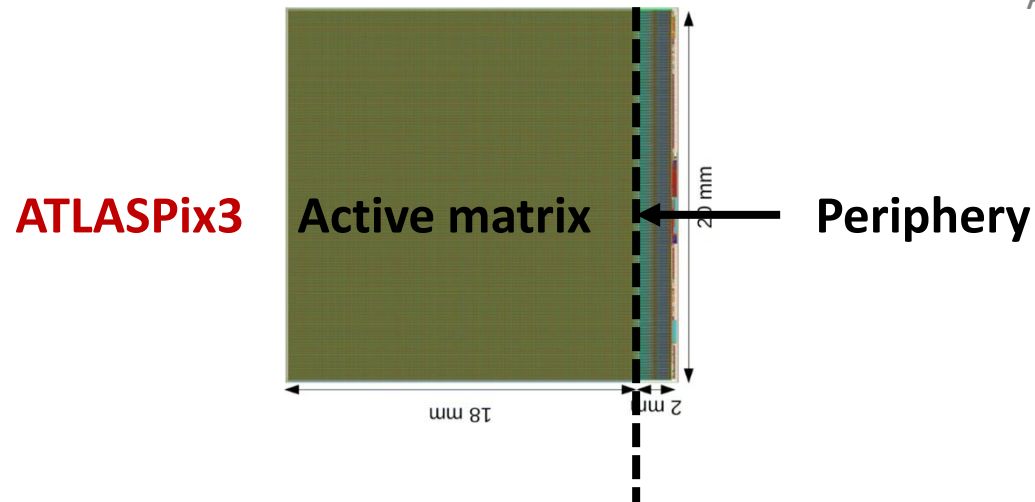

HV-CMOS detectors – ATLASPix3

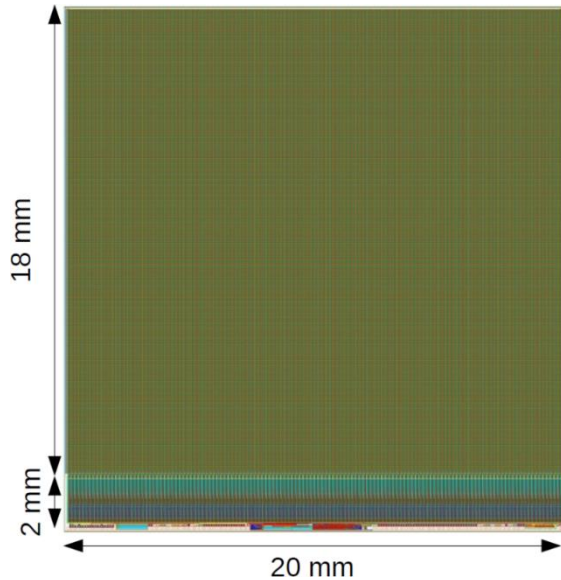

R. Schimassek, 2019

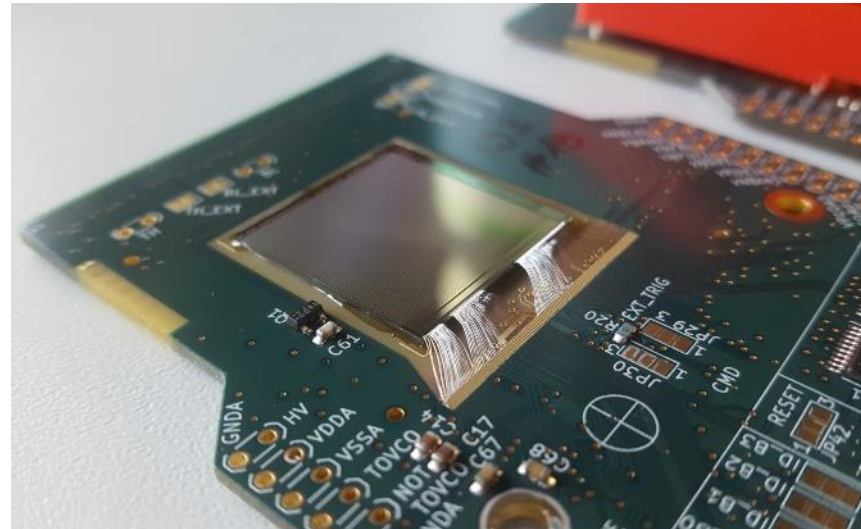

J. Hammerich, 2019

ATLASPix3 – Some chip details

- Matrix with 132 columns x 372 rows
- 150 μm x 50 μm pixel size
- Trigger latency $\leq 25 \mu\text{s}$
- Radiation hard design
- Serial powering (only one power supply needed)
- Data interface is very similar to ATLAS RD53 readout chip
- Power consumption is $\sim 200 \text{ mW/cm}^2$ (with 25 ns time resolution)

ATLASPix3 is the first full reticle pixel detector (2 cm x 2 cm) compatible with ATLAS ITk L4 requirements

RD50-MPW3 – Pixel schematic

Amplifier + feedback loop for reset

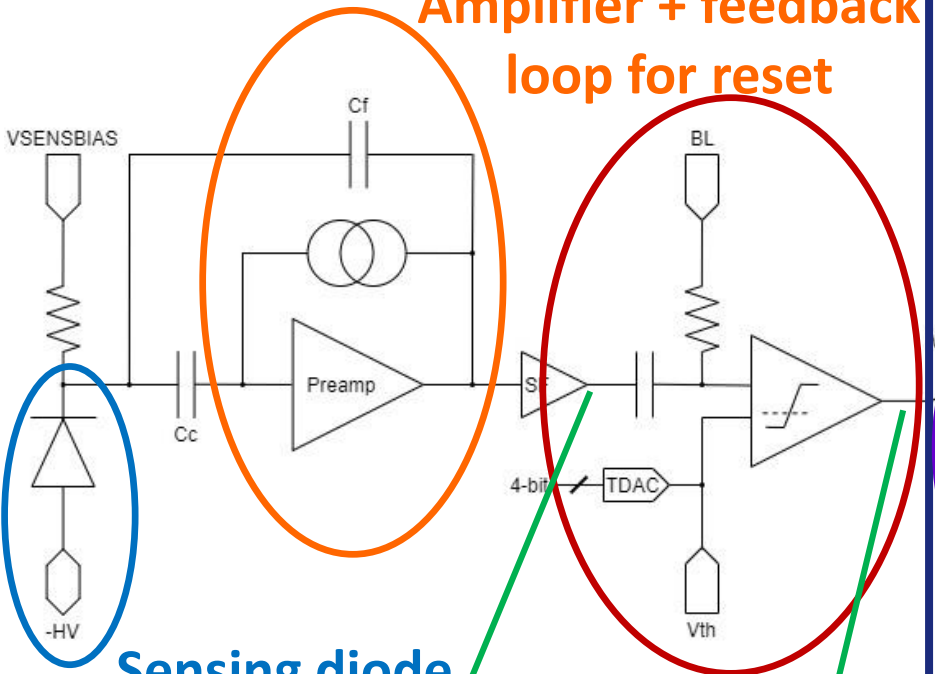

Sensing diode

Source follower output

Trimmable comparator

Comparator output

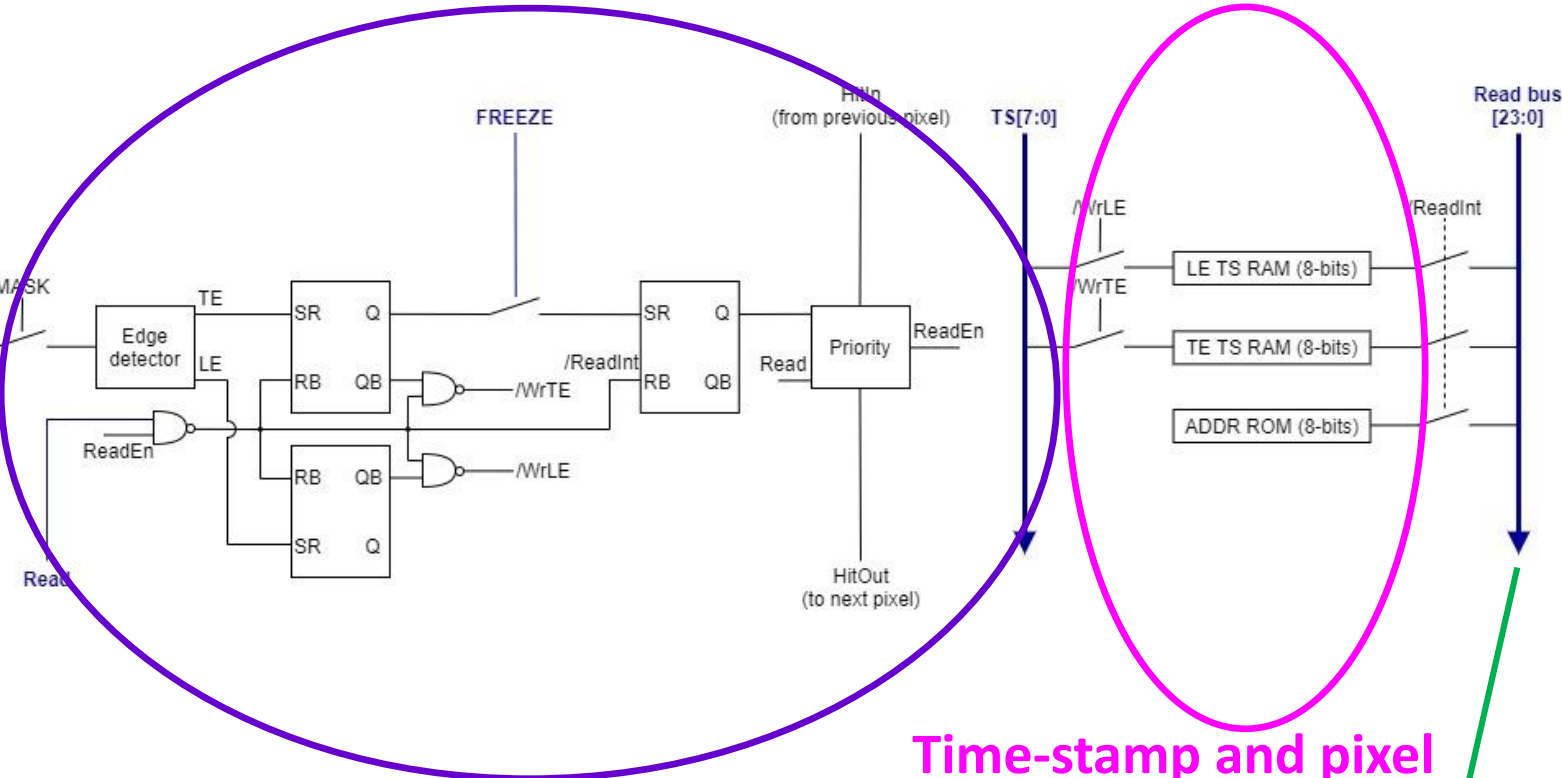

Processing digital readout electronics

Time-stamp and pixel address memories

Time-stamp and pixel address outputs

RD50-MPW3 – Layout

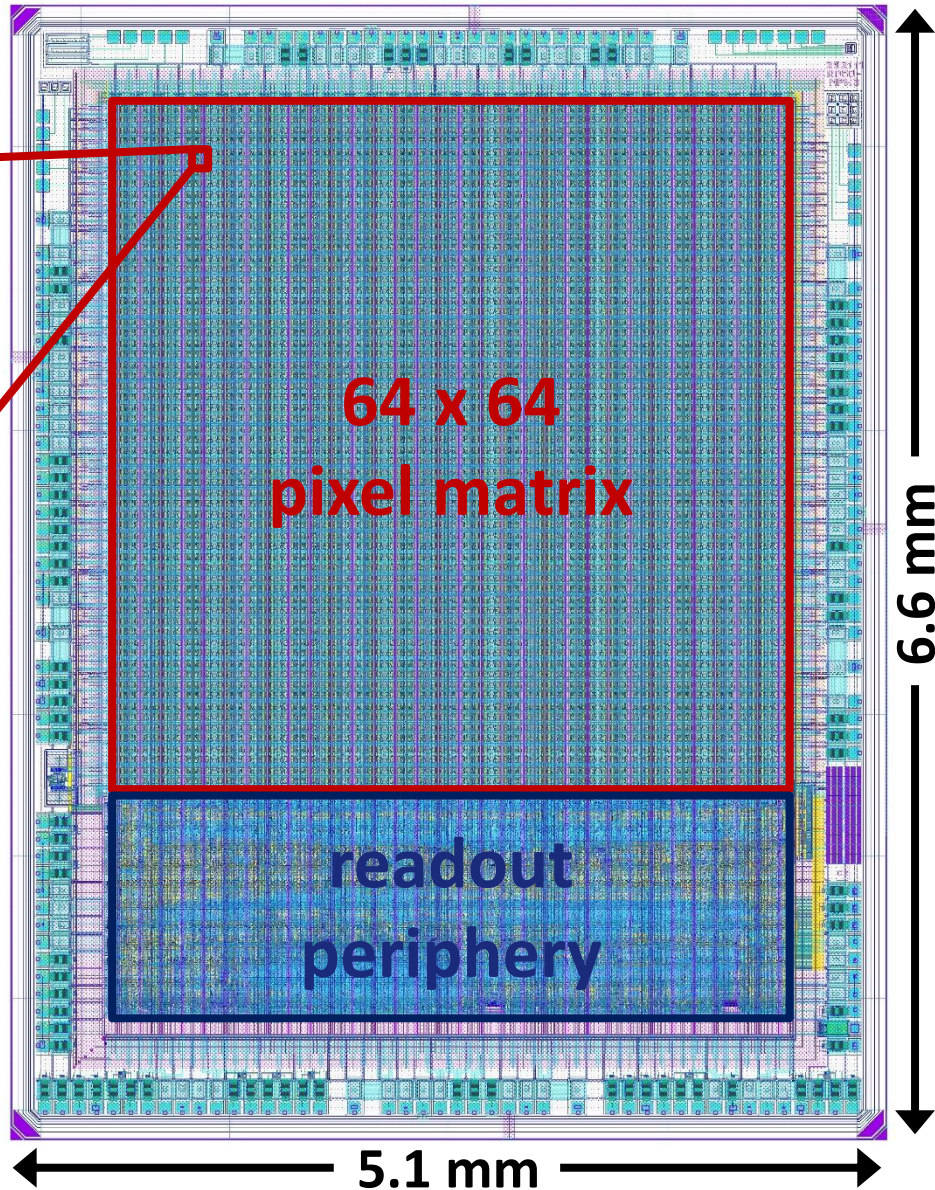
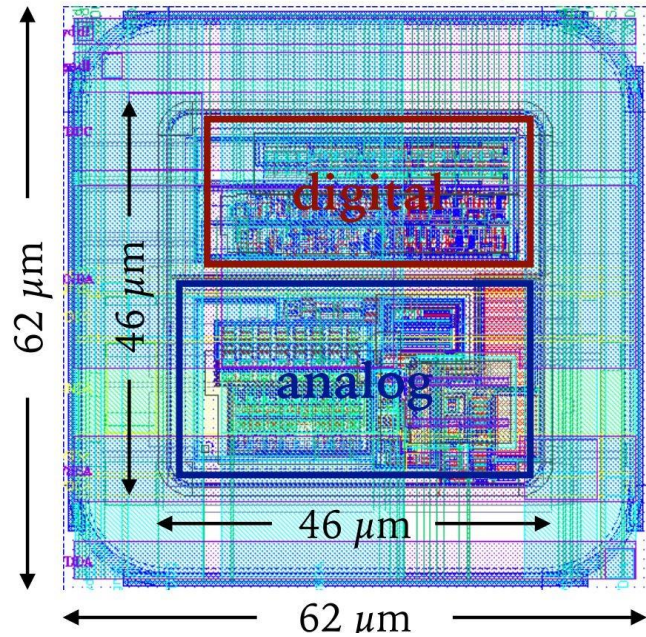

- Separation of analogue and digital circuits with different signal lines to minimise noise
- FE-I3 style readout
- Advanced digital readout periphery with 640 MB/s serialiser

RD50-MPW3 – Double column layout

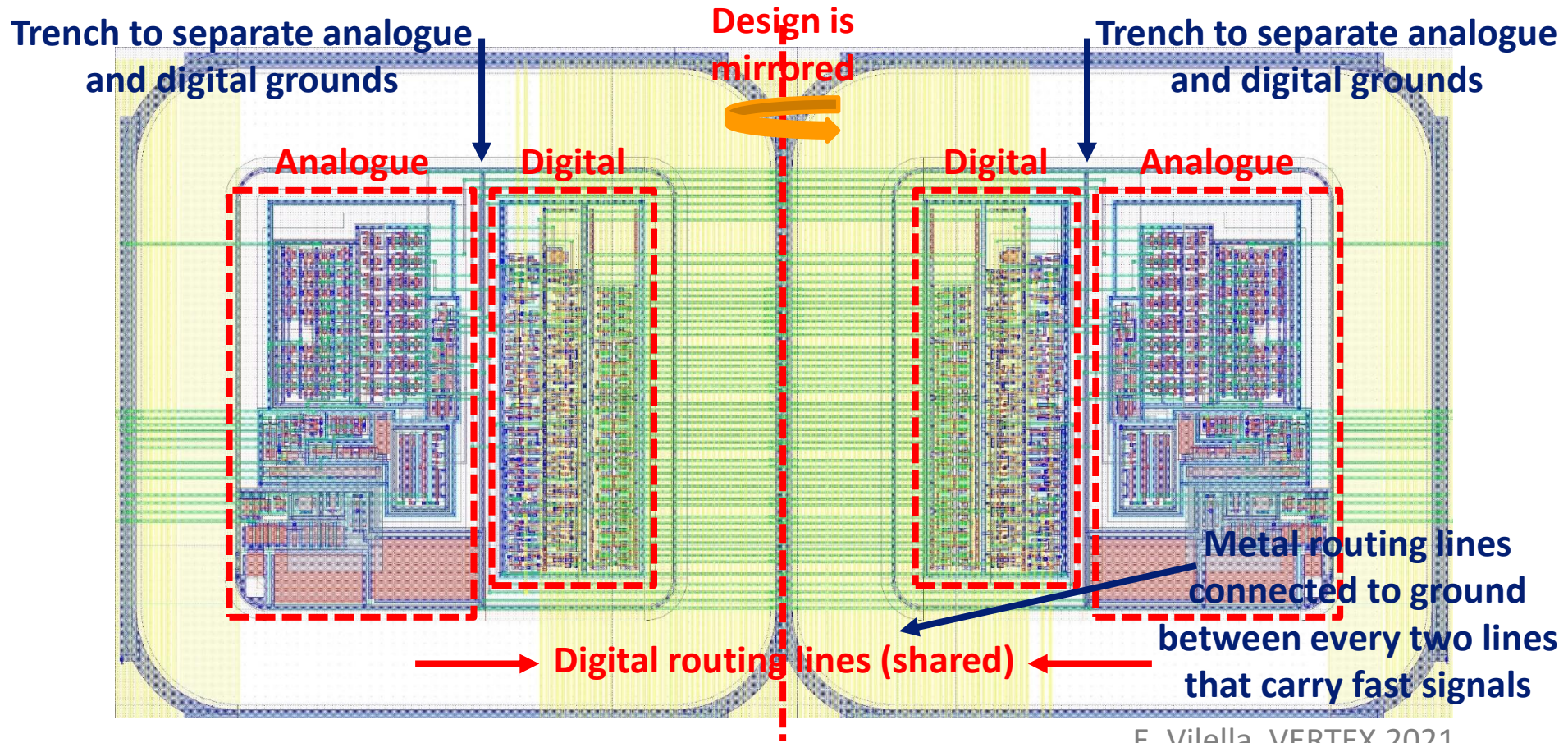

E. Vilella, VERTEX 2021

- **Double column scheme to alleviate routing congestion and minimise crosstalk**
 - Pixels within double column share many signals → ~ x0.5 less routing lines
 - Shared signals are digital input/outputs (TS IN, TS OUT, ADDR), control signals (Read, Freeze, etc.)

Sensor cross-section

- **150 nm HV-CMOS LFoundry**

- P-substrate/DNWELL sensing junction
- Topside p-type contacts to bias the p-substrate to HV
- Pixel readout electronics embedded inside DNWELL

e.g. RD50-MPWx pixel chips, hyperlinks:

[Vilella PoS\(Vertex2019\)019](#)

[Marco JPS Conf. Proc. 010008 \(2021\)](#)

[Vilella NIMA 2022 166826](#)

Breakdown
start

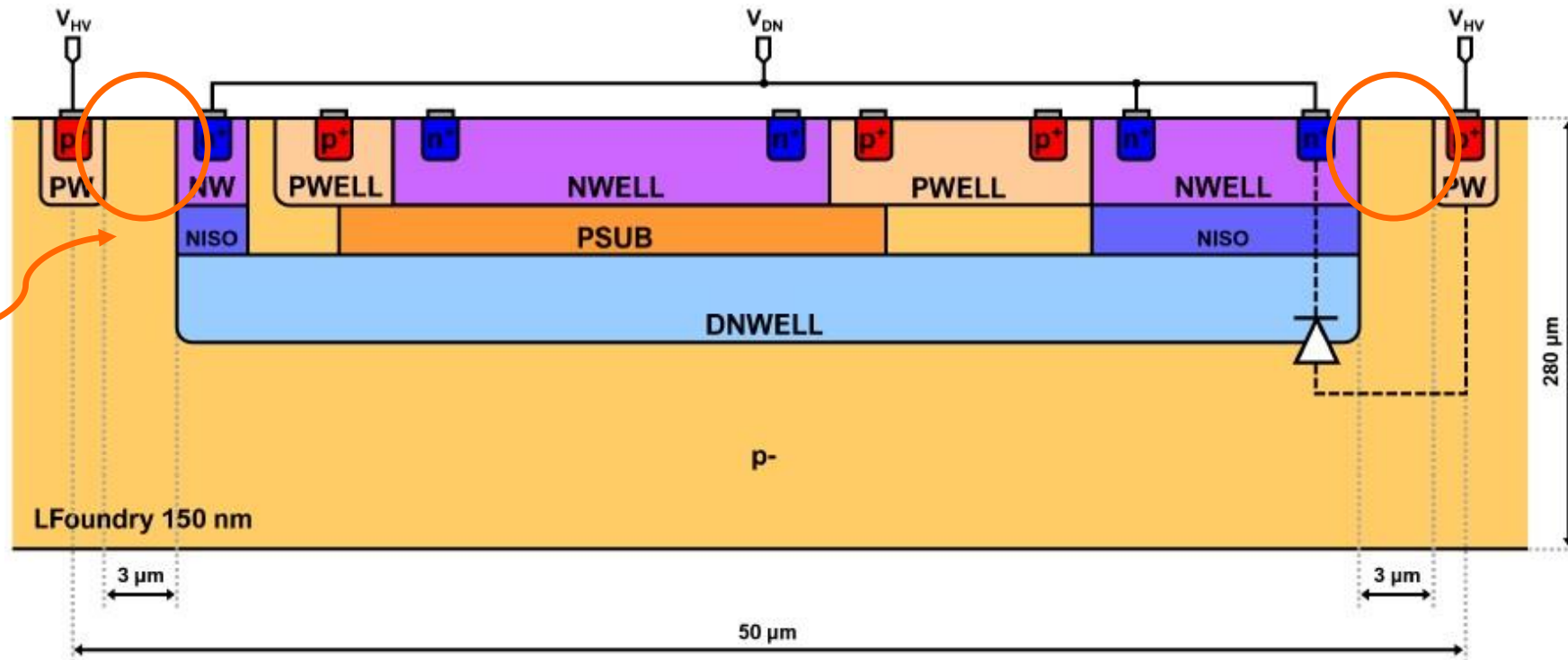

RD50-MPW3 – Pixel parameters and verification

Parameter	Value
Pixel size [$\mu\text{m} \times \mu\text{m}$]	62 x 62
Pixel capacitance [fF]	250
Gain [mV]	230 @ 5 ke ⁻
ENC [e ⁻]	120
ToT [ns]	55 @ 5 ke ⁻
Time-walk [ns]	9
Power consumption [μW]	22 @ VDD = 1.8 V

Pixel mixed-mode simulations

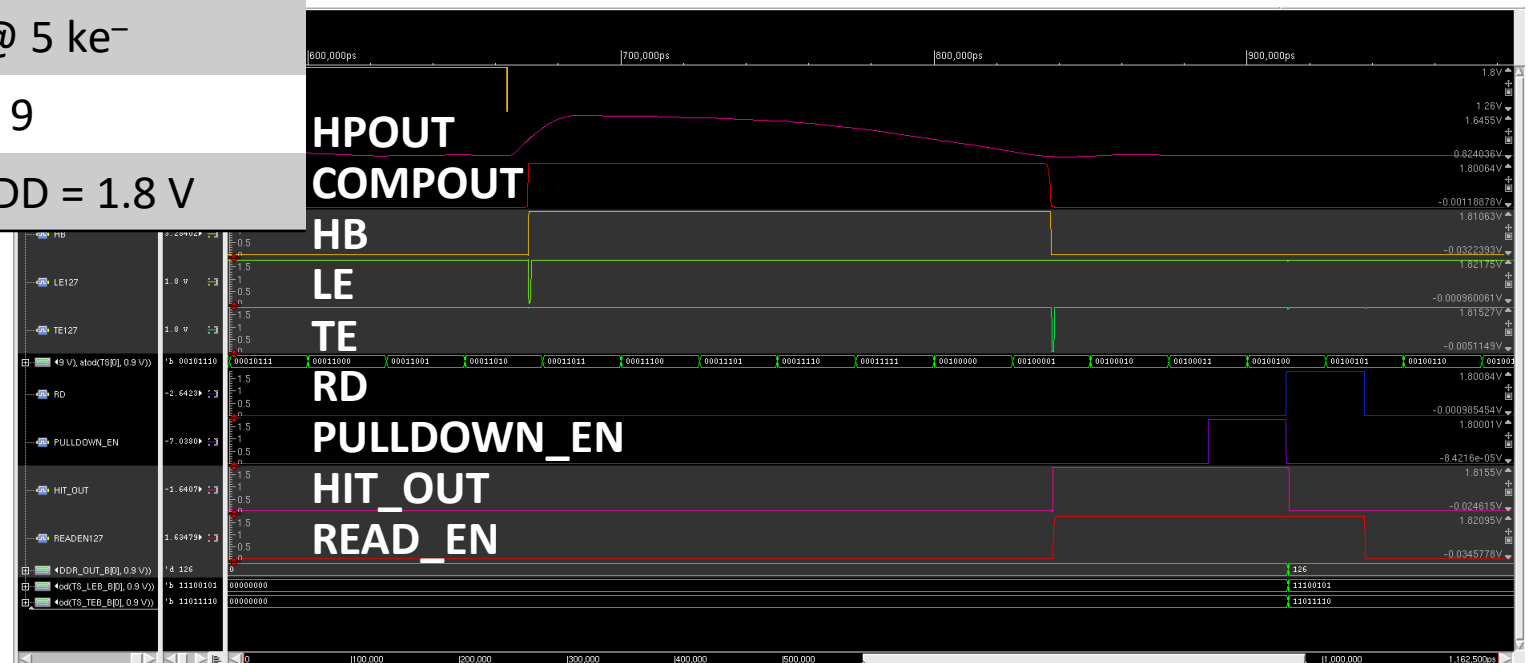

HV-CMOS applications in particle physics

■ Mu3e experiment at PSI in Switzerland

- To search for lepton flavour violating decays
- MuPix (HV-CMOS sensor chip, selected)
 - $\leq 50 \mu\text{m}$ thickness, minimum material
 - $80 \mu\text{m} \times 80 \mu\text{m}$ pixel size
 - $\leq 20 \text{ ns}$ time resolution
- Detector construction planned for 2023

■ Mighty Tracker upgrade at the LHCb experiment at CERN

- Major tracking detector system upgrade to cope with increased luminosity in coming runs
- MightyPix (HV-CMOS sensor chip, proposed)
 - $6E10^{14} \text{ 1 MeV } n_{\text{eq}}/\text{cm}^2$ radiation tolerance
 - $\leq 3 \text{ ns}$ time resolution
- To be installed during LS3 and LS4

■ Others: ATLAS ITk, CEPC, CERN-RD50...

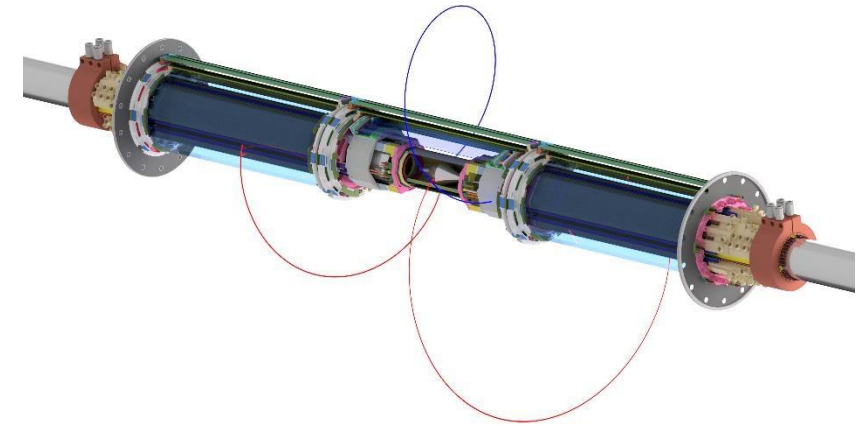

Mu3e

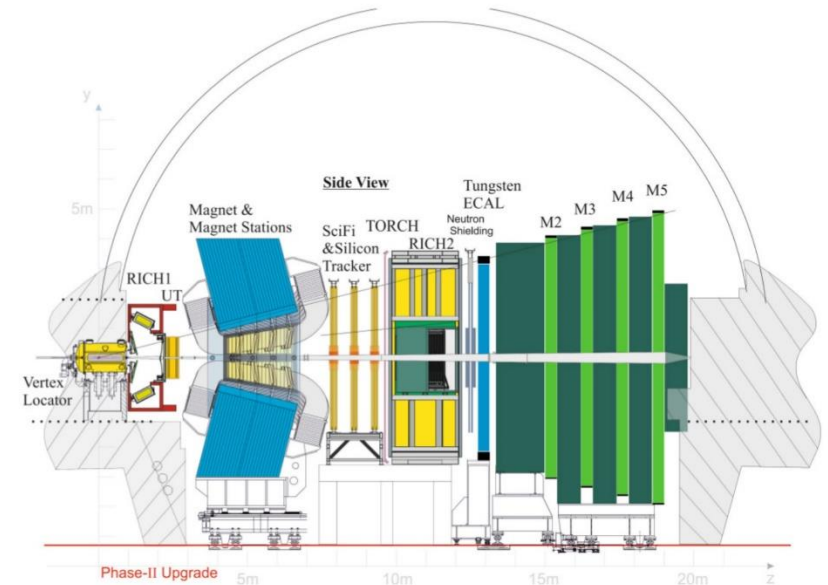

LHCb Upgrade II FTDR, 2022

Mighty Tracker upgrade at LHCb

- Proposed hybrid tracking detector to balance cost and physics/detector performance needs
- Three downstream tracking stations (T1, T2 and T3)
- Composed of
 - **Scintillating Fibre Tracker (SciFi)**
 - Outer region
 - Scintillating fibres with SiPM readout
 - Installed in LS2, replacements in LS3
 - **Monolithic High Voltage CMOS sensors**
 - Inner Tracker (IT) and Middle Tracker (MT)
 - To meet the anticipated requirements on granularity, radiation tolerance and cost
 - Installation in two stages: LS3 (Inner Tracker) and LS4 (Middle Tracker)
 - Total silicon area (IT + MT) $\sim 18 \text{ m}^2$

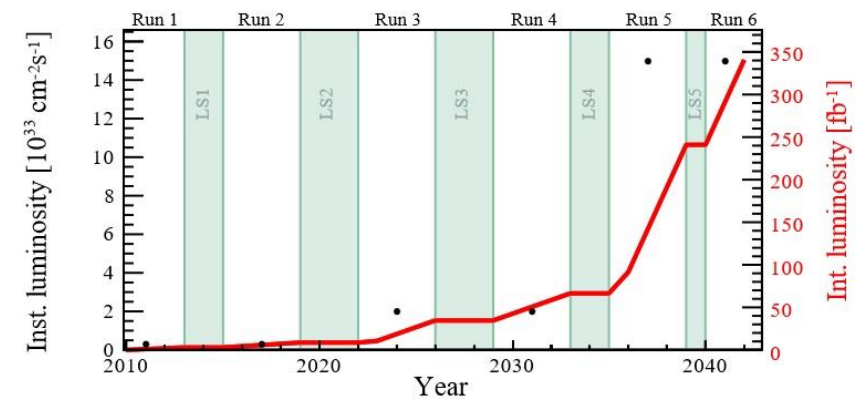
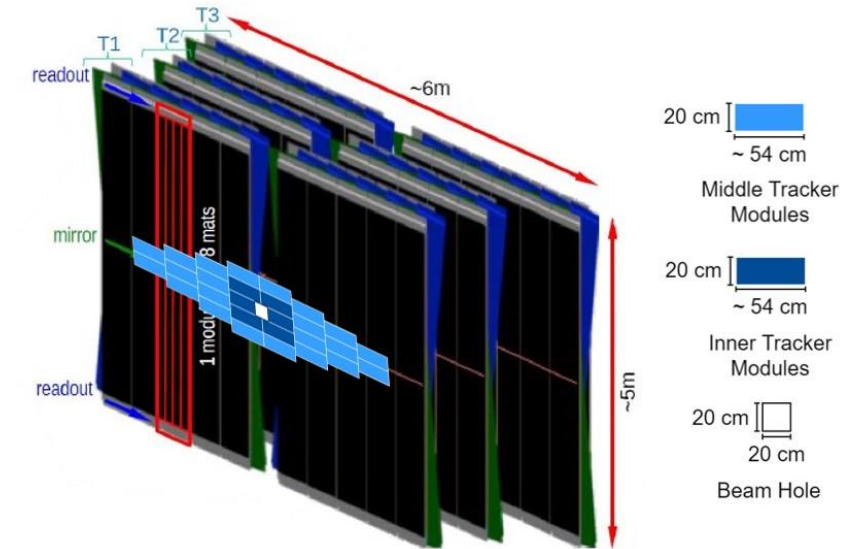

LHCb Upgrade II FTDR, 2022

Mighty Tracker upgrade – High Voltage CMOS sensor

- Dedicated R&D programme to develop a High Voltage CMOS sensor chip (MightyPix) that meets the Mighty Tracker requirements:

Pixel size	< 100 μm x 300 μm
Timing resolution	\sim 3 ns within 25 ns window
In-time efficiency	> 99% within 25 ns window
Radiation tolerance	$6\text{E}10^{14}$ 1 MeV $n_{\text{eq}}/\text{cm}^2$ (includes safety factor)
Power consumption	< 150 mW/cm ²
Data transmission	4 links of 1.28 Gb/s each
Compatibility with the LHCb readout system	

LHCb-INT-2019-007, 2019

- The programme foresees several High Voltage CMOS sensor chip submissions

Mighty Tracker upgrade – MightyPix

First High Voltage CMOS sensor chip dedicated to the Mighty Tracker

Chip	MightyPix1 (builds on MuPix and ATLASPix chips)
Technology	TSI 180 nm
Pixel size	55 μm x 165 μm
Pixel matrix	320 rows x 29 columns
Chip size	0.5 cm x ~2 cm (prototype size) $\frac{1}{4}$ of final MightyPix size \rightarrow $\frac{1}{4}$ width, full column length

First prototype compatible with LHCb readout system

- Runs with LHC clock at 40 MHz
- Uses IpGBT protocol
- Meets TFC and ECS requirements

Designed by KIT with some inputs from Uni. Liverpool

Submitted in May 2022 for fabrication; delivery expected in December 2022

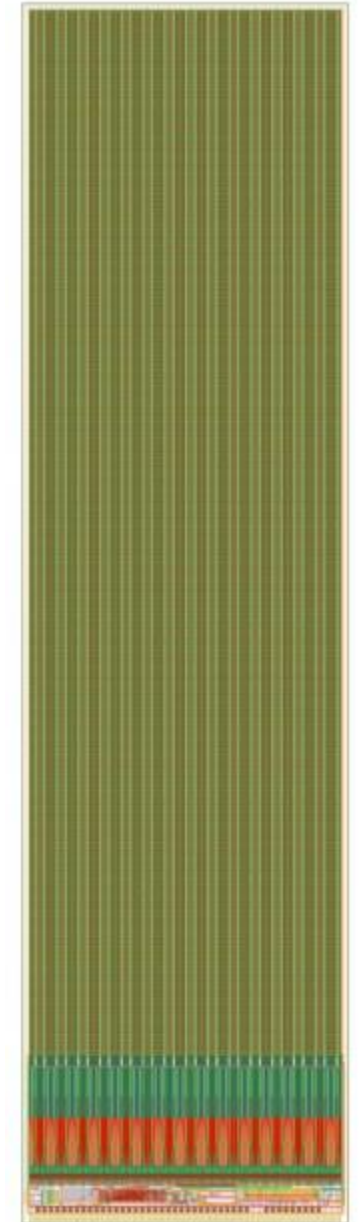

KIT

Thank you for your attention

