



Queen Mary

University of London

Science and Engineering

# Photonics

Peter R Hobson

Professor of Physics

School of Physical & Chemical Sciences

UK Advanced Instrumentation Training: May 30 2023

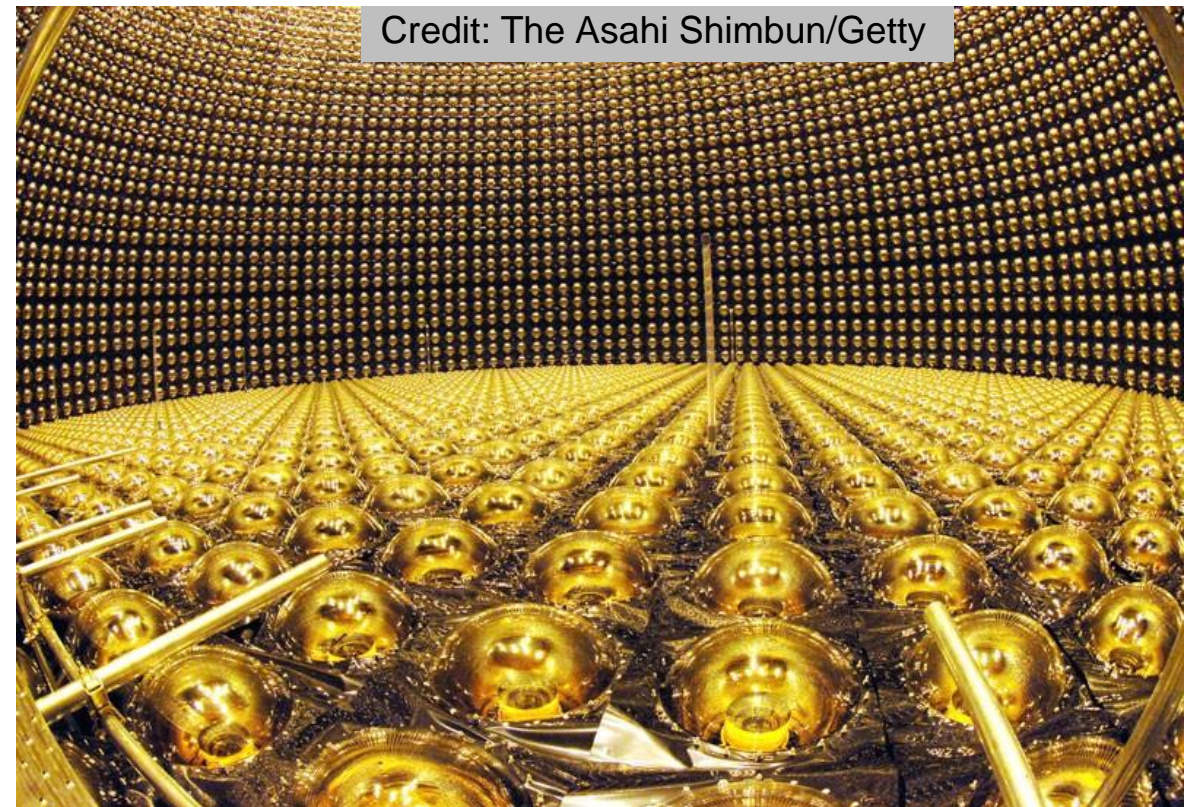

# Photonics in Particle Physics

- “The technology of generating and harnessing light and other forms of radiant energy whose quantum unit is the photon” (from *Photonics Spectra* magazine)
- In our context it is
  - The detection of light generated by some process related to the measurement of some property of particles (e.g. Energy or velocity).
  - The transmission and reception of analogue & digital information connected with the electrical signals from particle detectors.

# What systems are used in Particle Physics?

- Calorimeters (which measure energy and position)
  - Scintillation light
  - Cherenkov light
- Time-of-flight
  - Fast scintillators used to determine the speed of a particle
- Fibre Trackers
- Readout of electronics particularly in large hermetic detectors. (I will not cover this aspect)
- Fibre backbone for Local and Wide Area Networks (I will not cover this aspect)

# What devices are discussed in this lecture?

- Solid-state (silicon)
  - Photodiodes (including avalanche)
  - SiPM (“Geiger-mode” devices)
  - Imaging SiPM arrays
- Photomultipliers (external photoelectric effect)
  - Devices for low magnetic fields (high gain)
  - Devices for high magnetic fields (low gain)
- Hybrid devices

# What devices are discussed in this lecture?

## Photodetectors

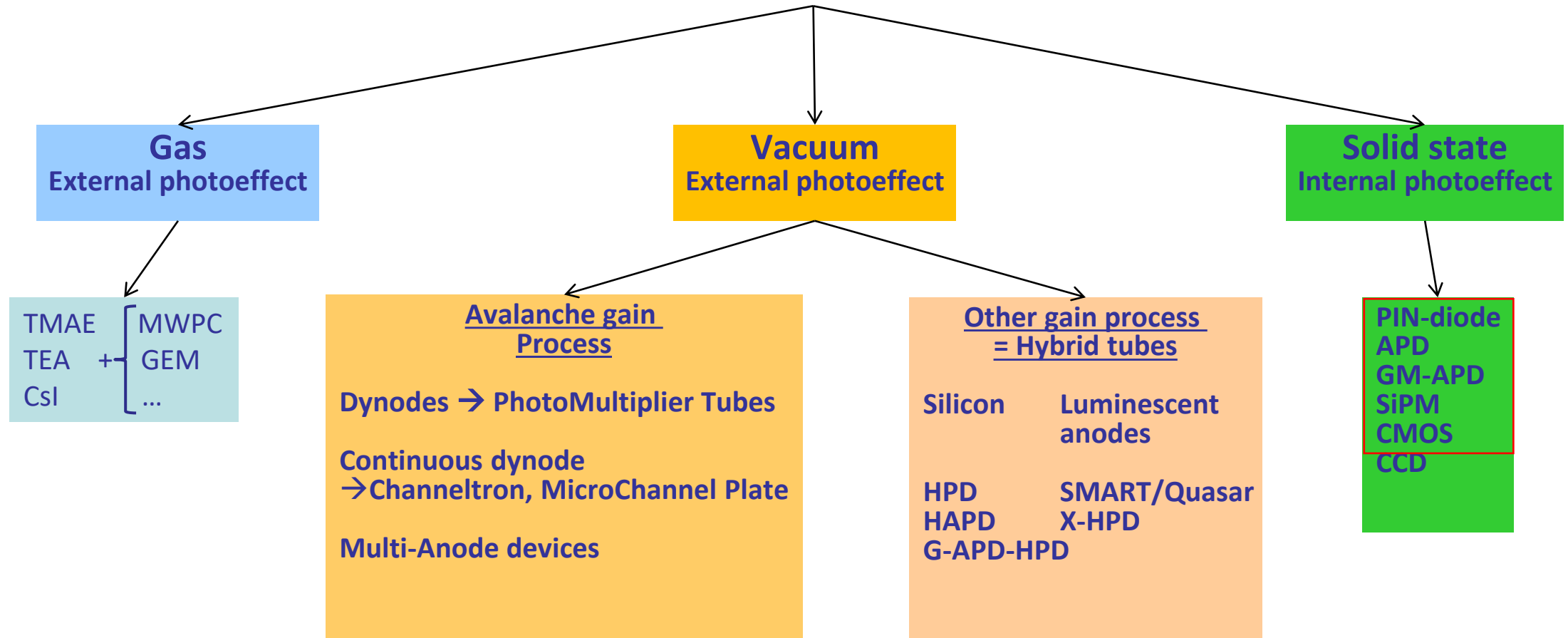

# The human eye (historic!)

- Detection of  $\alpha$  particles by Geiger & Marsden (1909) using ZnS(Ag) scintillator screens
  - Visual detection of scintillation light
  - Rate limited to about  $60 \text{ s}^{-1}$
  - Each detected flash contained around 300 photons entering the observer's eye
- Last important visual experiment was the disintegration of Li nuclei by protons (Cockcroft & Walton (1932))
  - Used a human coincidence counter technique

# Noise in photodetection

- Fundamental noise (note dependence on the detection bandwidth  $df$ )
  - Shot noise from **signal current** and from “dark current”
    - $d\langle I^2 \rangle_{shot} = 2eI_0 df$
  - Thermal noise in a resistor (Johnson noise)
    - $d\langle I^2 \rangle_{therm} = \frac{1}{R} 4kT df$
    - $d\langle v^2 \rangle_{therm} = R 4kT df$
- Additional noise from statistical fluctuations in avalanche or electron multiplier gain need to be considered for photodetectors such as the avalanche photodiode (APD) and photomultiplier.

# Junction photodetectors

- These use the *internal photoelectric effect*
- A photon with energy larger than the bandgap of the material generates an electron-hole pair (eh-pair) with some probability  $< 100\%$
- The eh-pair is separated by an internal field (e.g. a junction inside a diode)

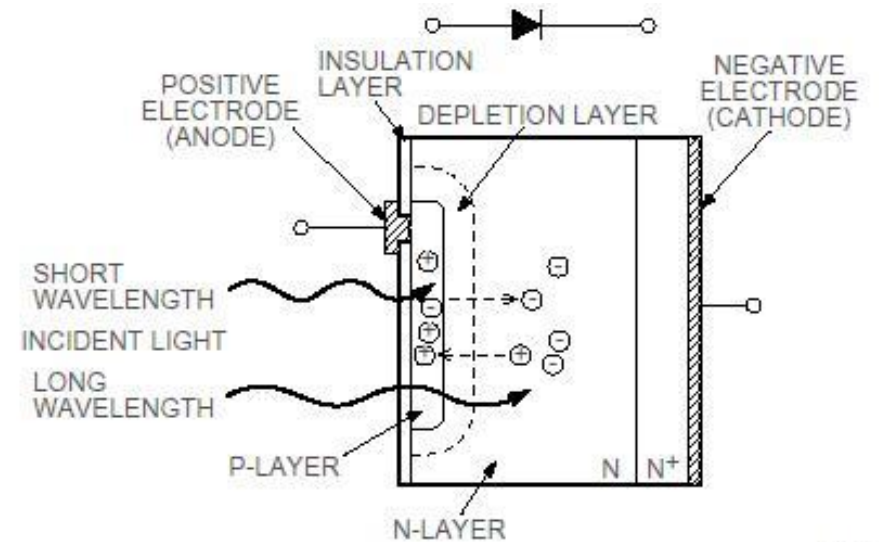
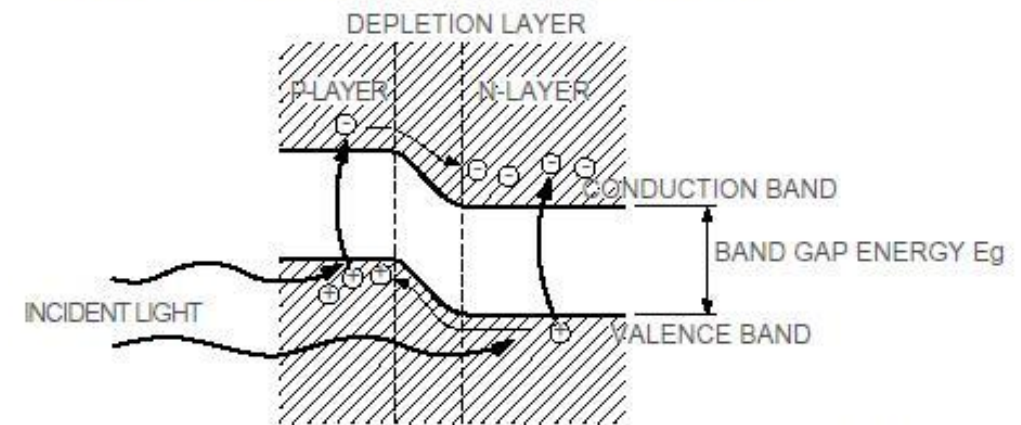

Figure 1-2 Photodiode P-N junction state





# Junction photodetectors

- Equivalent electrical circuit:
- Capacitance is a function of reverse bias (until full-depletion)
- Thermal noise  $I'$  arises from the shunt resistance  $R_{sh}$   $= \sqrt{\frac{4k T B}{R_{sh}}}$  [A]

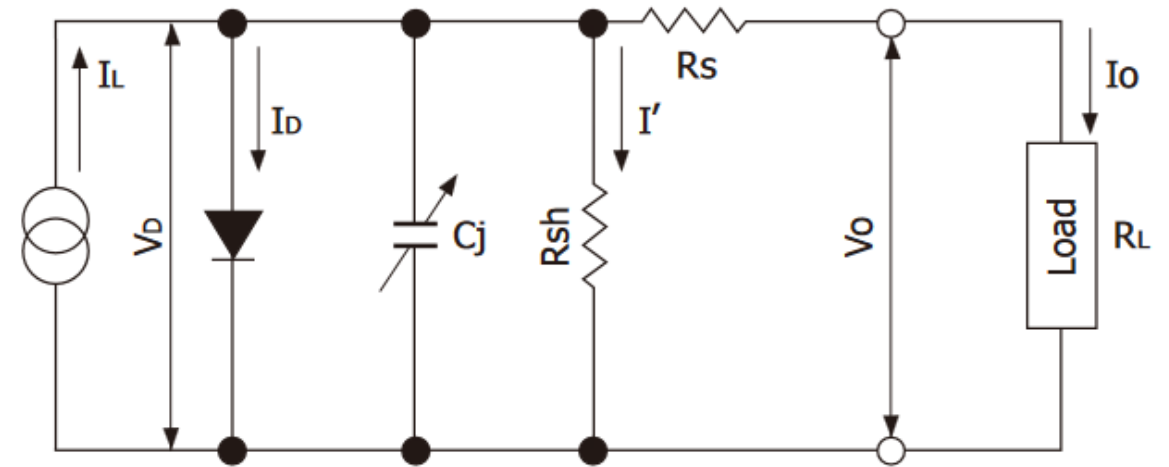

- $I_L$  : current generated by incident light (proportional to light level)
- $V_D$  : voltage across diode
- $I_D$  : diode current
- $C_j$  : junction capacitance
- $R_{sh}$ : shunt resistance
- $I'$  : shunt resistance current
- $R_s$  : series resistance
- $V_o$  : output voltage
- $I_o$  : output current

# Absorption of Light

- In ideal (non scattering) materials the absorption of light is governed by the **Beer-Lambert law**. This relates transmittance,  $T$ , to absorbance,  $A$ , and *optical depth*  $\tau$ , by the fundamental relationship

$$T = e^{-\tau} = 10^{-A}$$

If the *attenuation coefficient*  $\mu$  is given and the physical depth  $l$ , then

$$T = e^{-\mu l}$$

For some actual values for real semiconductors see this site:

<http://www.ioffe.ru/SVA/NSM/Semicond/>

# Silicon photodiodes

- Silicon is the primary material since in general we are detecting fast scintillation or Cherenkov light (UV and visible). SiC useful for a UV only response and for high temperature operation.
- Silicon diode technology is well advanced and the peak quantum efficiency (QE) is high (around 80%)
- Silicon devices are tolerant to quite high radiation levels, although there are problems with hadrons.
- Silicon photodiodes are linear over many orders of magnitude.
- Small devices can have cut-off frequencies  $\sim 1$  GHz
- Remember that they make good ionising radiation sensors too! This can be a problem when you have a mixed light/ionising radiation environment.

# Ideal behaviour

Photocurrent is proportional to the optical (signal) power

How large is the responsivity  $R$  (in A/W) and how does it vary with wavelength for an ideal photodetector?

In an ideal photodiode with unity gain (i.e. a pn or pin structure or a Schottky device) one gets one e/h pair per absorbed photon with energy  $>$  band-gap. This has the *largest* value when the photon energy is the *smallest* allowed, i.e. just above the band gap. Numerically, for wavelengths in nm and band-gaps in eV:

$$R = \frac{q}{E_{ph}} \qquad R = \frac{1}{E_g[eV]} \approx \frac{\lambda[nm]}{1240}$$

# Intrinsic silicon

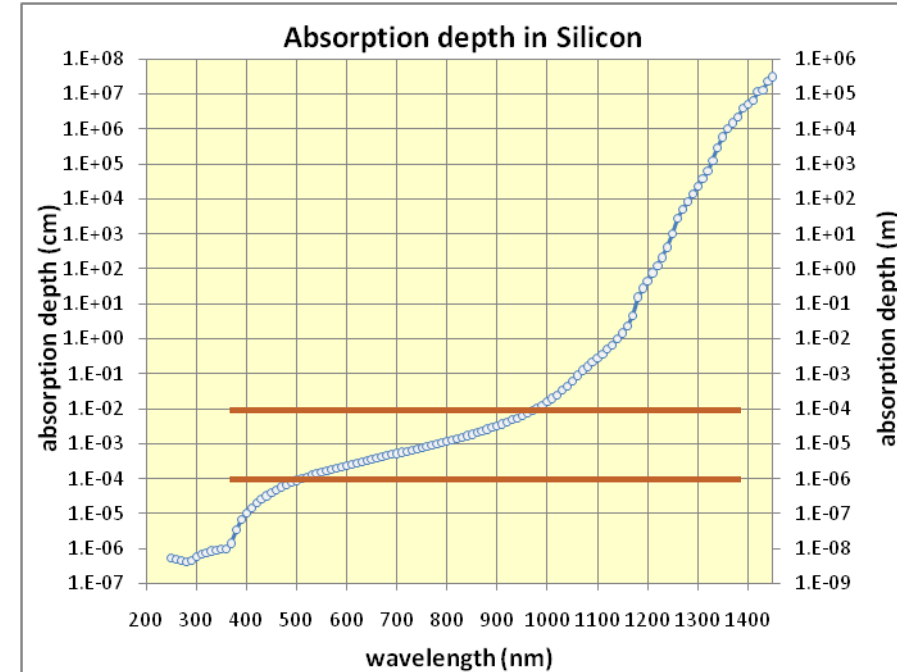
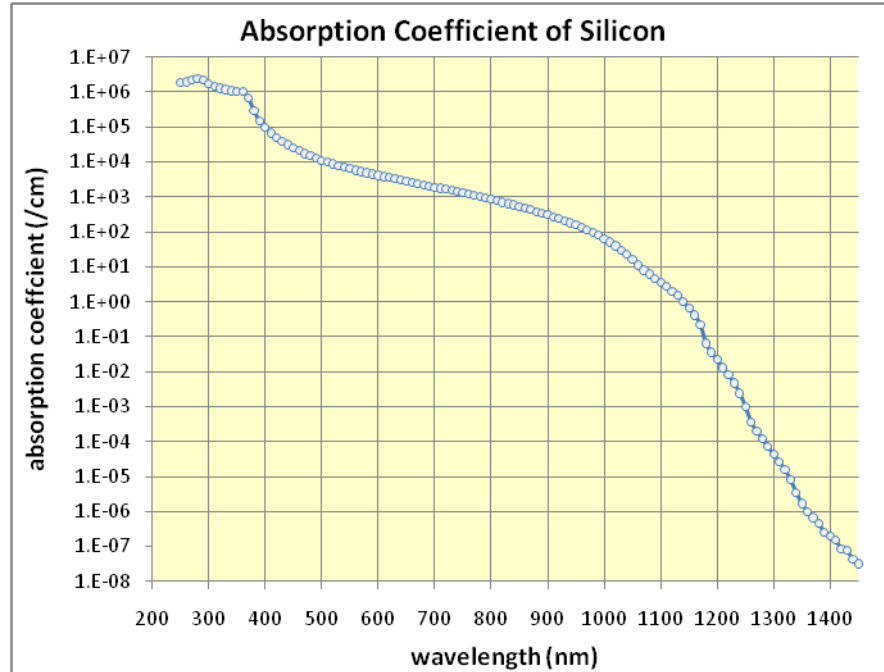

Note that silicon is an indirect bandgap semiconductor so it has quite a complicated absorption spectrum. Red lines are for 1 μm and 100 μm thickness.

M. A. Green and Keevers, M. J., "Optical properties of intrinsic silicon at 300 K", Progress in Photovoltaics: Research and Applications, vol. 3, pp. 189 - 192, 1995.

2. M. A. Green, "Self-consistent optical parameters of intrinsic silicon at 300 K including temperature coefficients", Solar Energy Materials and Solar Cells, vol. 92, pp. 1305–1310, 2008.

# A commercial large area (10×10 mm<sup>2</sup>) PIN diode

■ Photo sensitivity linearity (S1227-1010BQ/-1010BR)

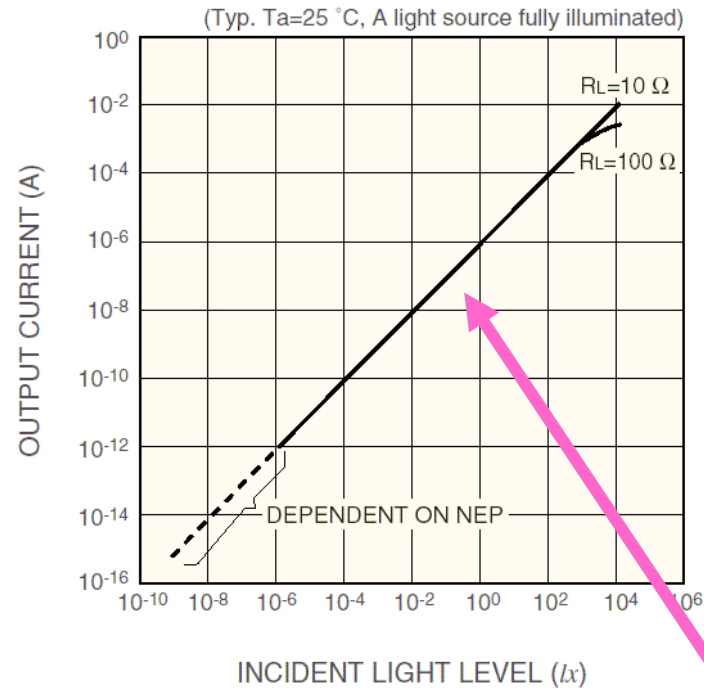
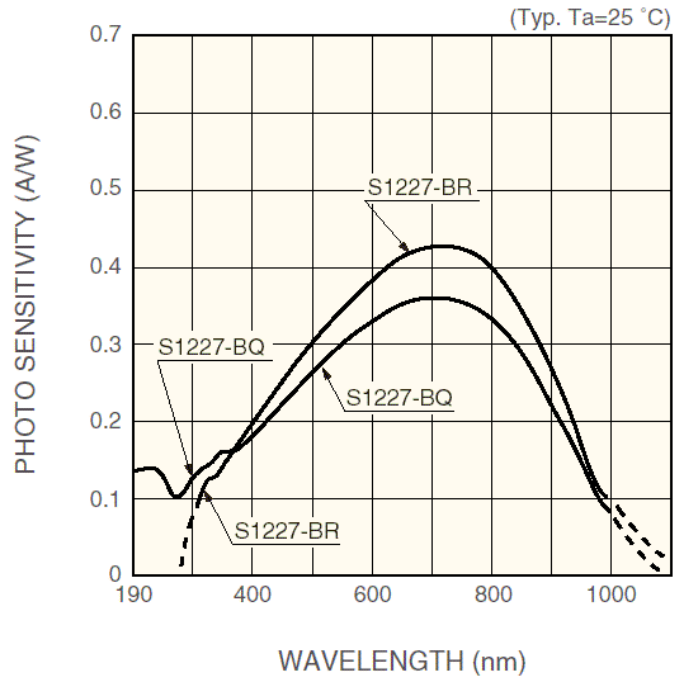

Data from Hamamatsu Photonics

Note 8 to 10 decades of linear response

# Avalanche Photodiode (APD) – a diode with gain

- A junction photodetector *with internal gain*
- Uses *impact ionisation* that occurs at very high internal electric fields.
- The avalanche process is an *additional* source of noise (excess noise factor  $F$ )
- Use the **majority carrier** to minimise *the excess noise*
  - Use an  $n^+ - p - \pi - p^+$  structure for silicon

Avalanche mechanism:

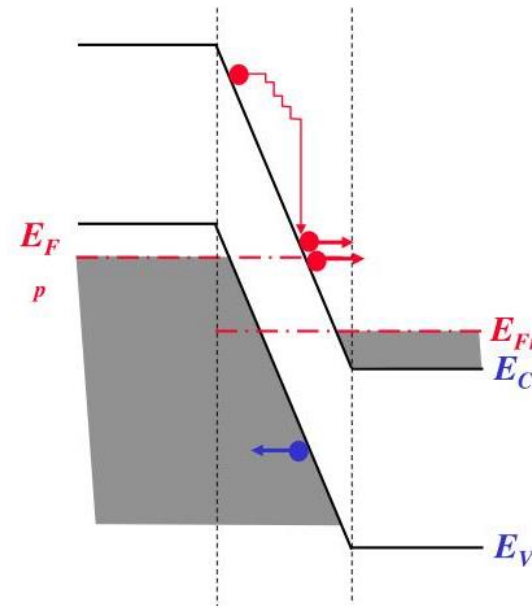

Generation of the excess electron-hole pairs is due to impact ionization.

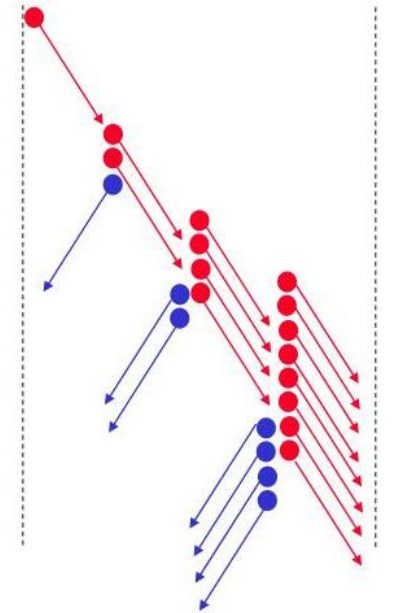

Expanded view of the depletion region

# Silicon “Reach-through” APD

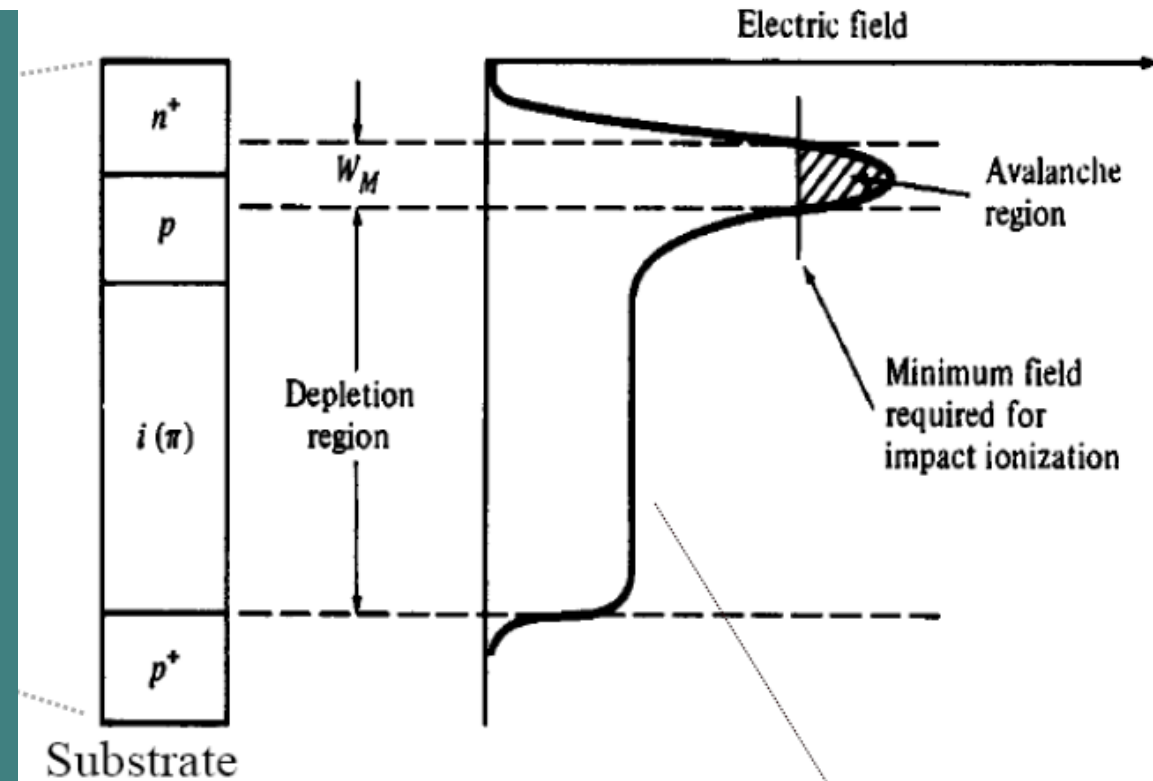
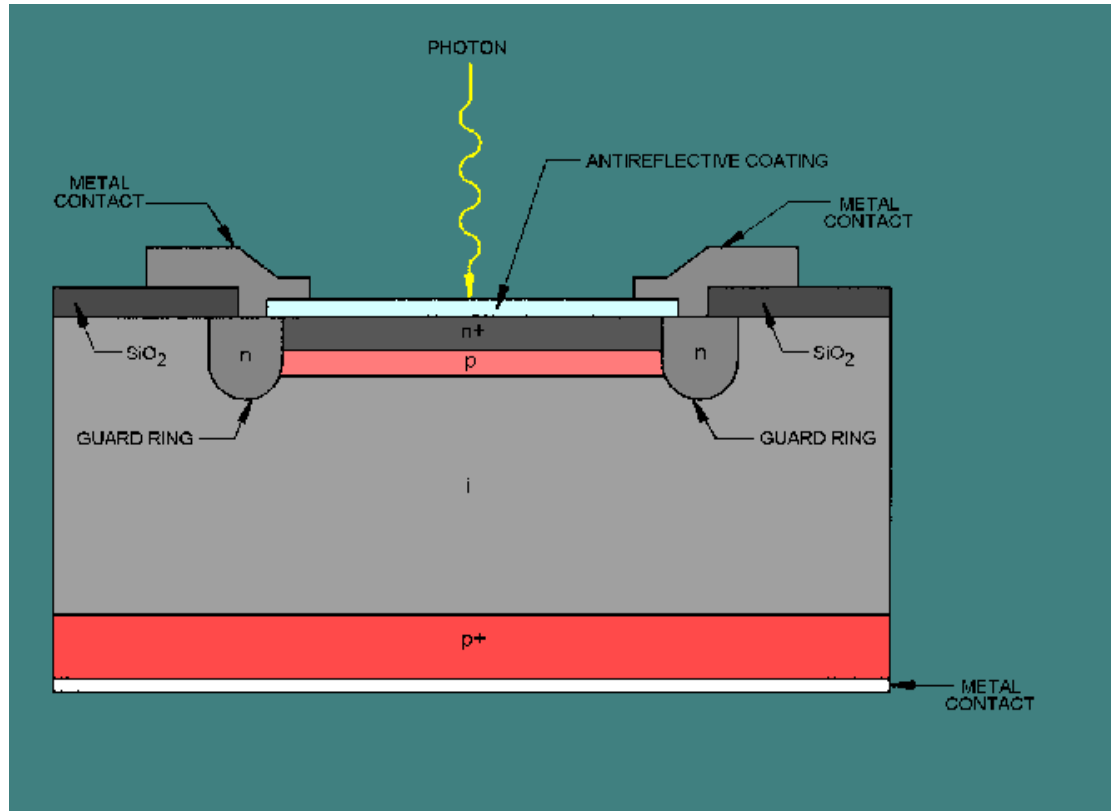

Silicon RAPD structure, electrons are the carriers multiplied here.

Figure from <http://www.tpub.com/neets/tm/111-4.htm>

$$\frac{dE}{dx} = \frac{\rho(x)}{\epsilon}$$



# A commercial large area (5×5 mm<sup>2</sup>) APD

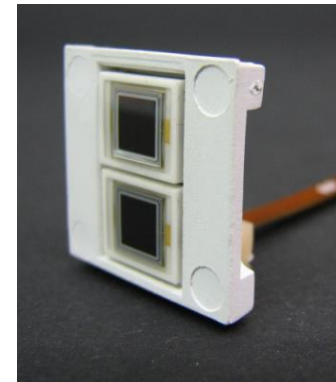
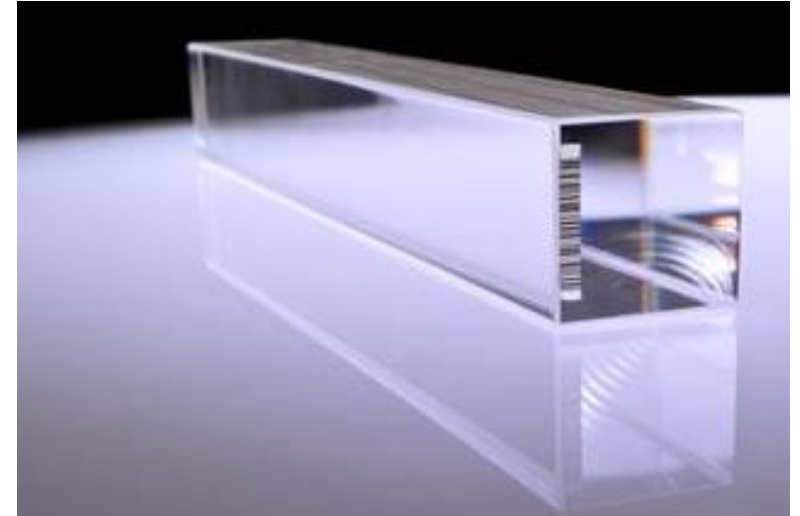
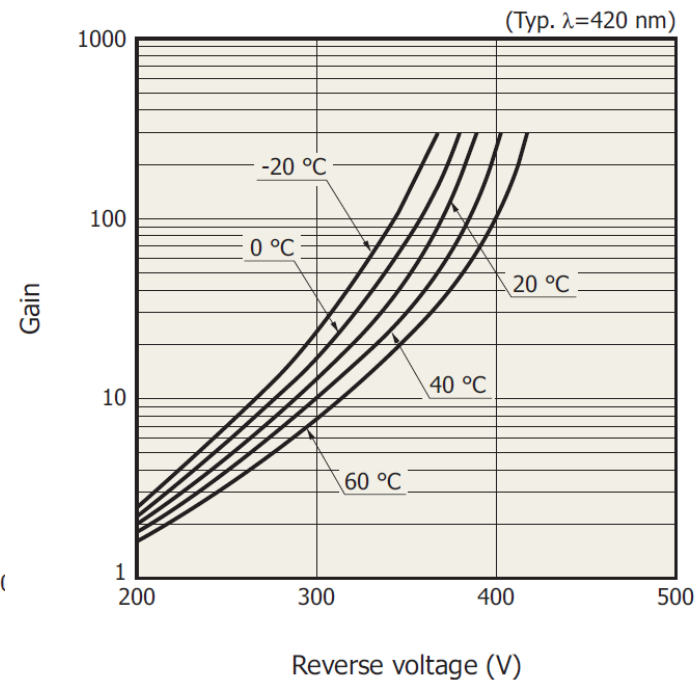
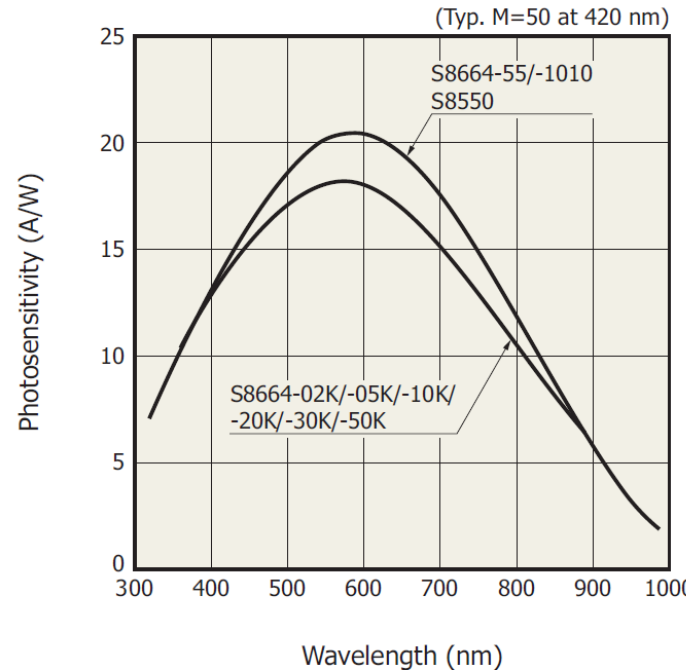

CMS barrel ECAL  
crystal (PbWO<sub>4</sub>) and  
associated APD  
readout.

# Silicon photomultiplier (SiPM)

Take an APD, increase the reverse bias to get a very high gain (Geiger mode) .

PROBLEM! The **first photon detected** will generate a huge avalanche in the high field region which could be destructive.

SOLUTION: limit current with external quench resistor.

Clever idea: couple together lots of tiny APD (cells) in parallel to make a moderate area device (several square millimetres), then can get an quantised output (up to  $\sim$  the number of cells) which allows photon counting.

Geiger mode also produces a fast rise-time signal so get good timing information (Time-of-Flight applications for example).

# SiPM

[400 pixel SiPM device; Hamamatsu]

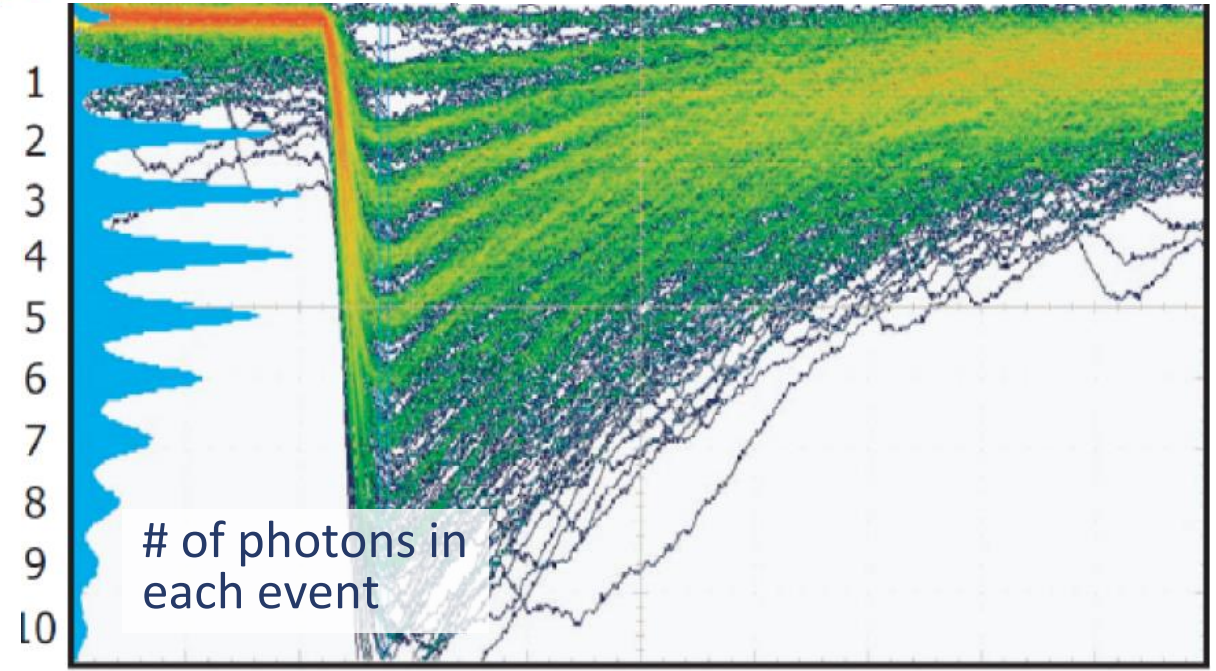
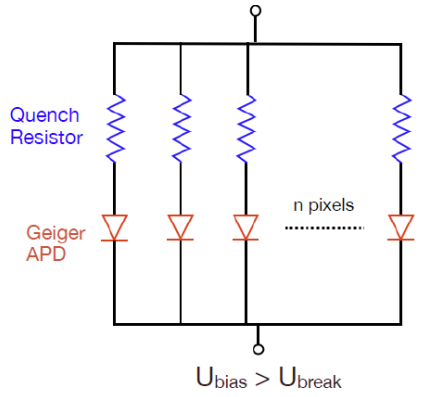
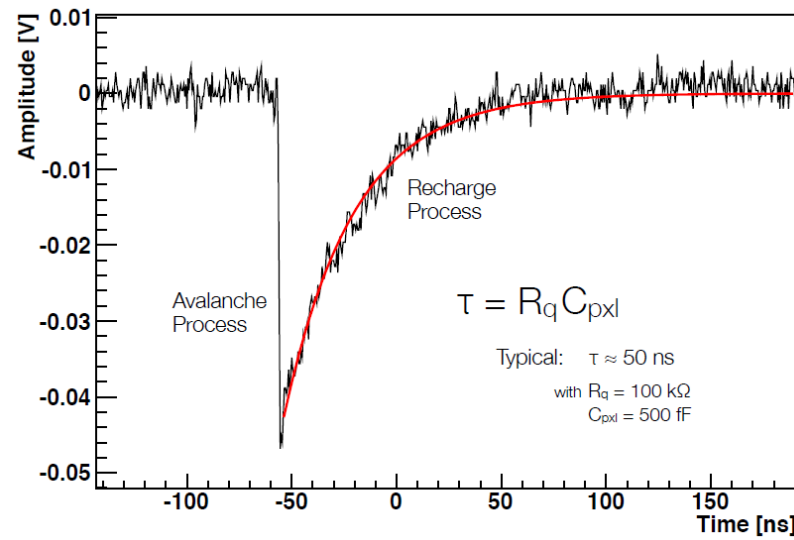
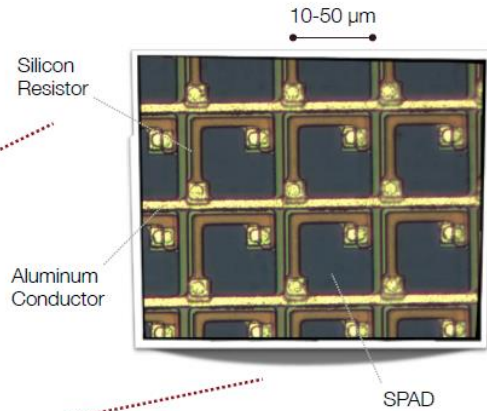
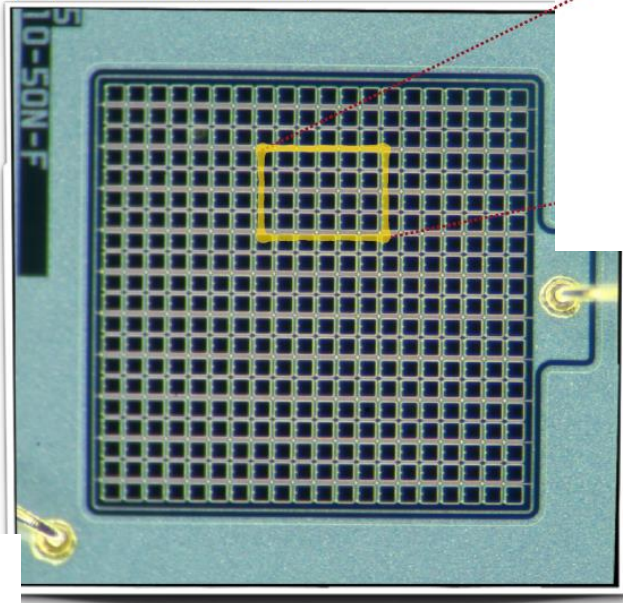

# SiPM – photon detection efficiency (PDE)

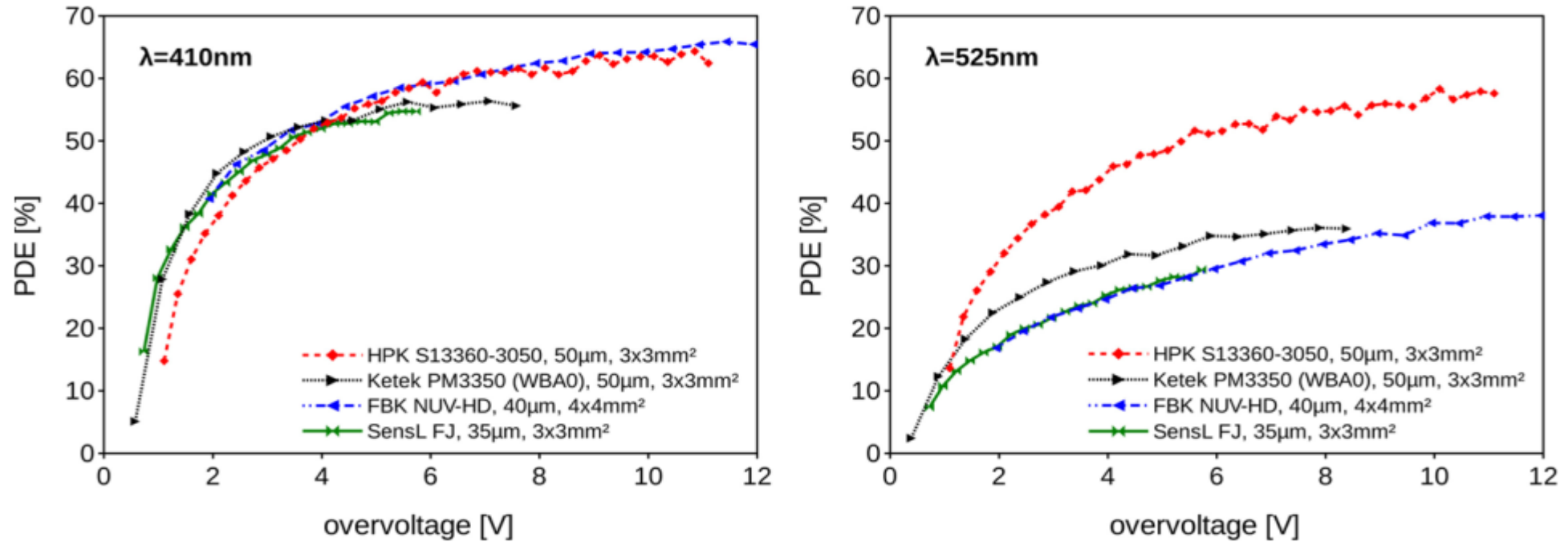
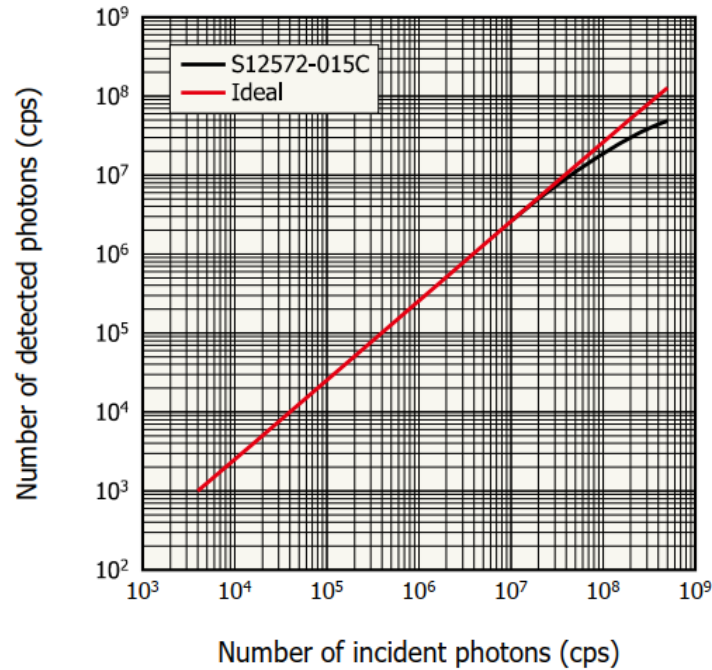

**Fig. 1** PDE as a function of SiPM bias overvoltage (difference of operating voltage to the SiPM breakdown voltage) at 410 nm (left) and 525 nm (right) for SiPMs developed by different producers (HPK, Ketek, FBK and SensL). The microcell size and SiPM active area are reported in the Legend. The measurement uncertainty of  $\sim 5\%$  is not shown in the plot. Figure adapted from

Eur. Phys. J. Plus (2022) 137:170

<https://doi.org/10.1140/epjp/s13360-021-02159-4>

# SiPM – linearity, timing



Linearity for Hamamatsu S12572-015C

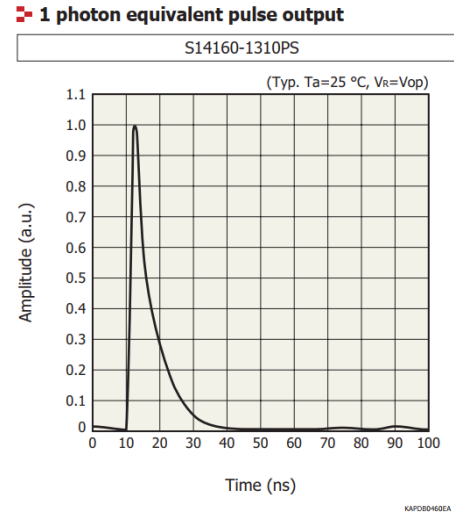

Pulse output for Hamamatsu S14160-1310PS

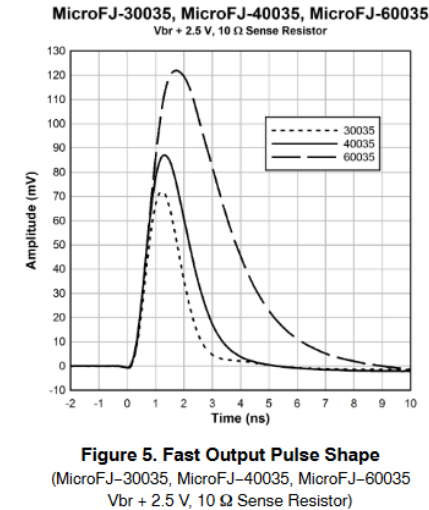

Fast pulse output for onsemi J-series SiPM

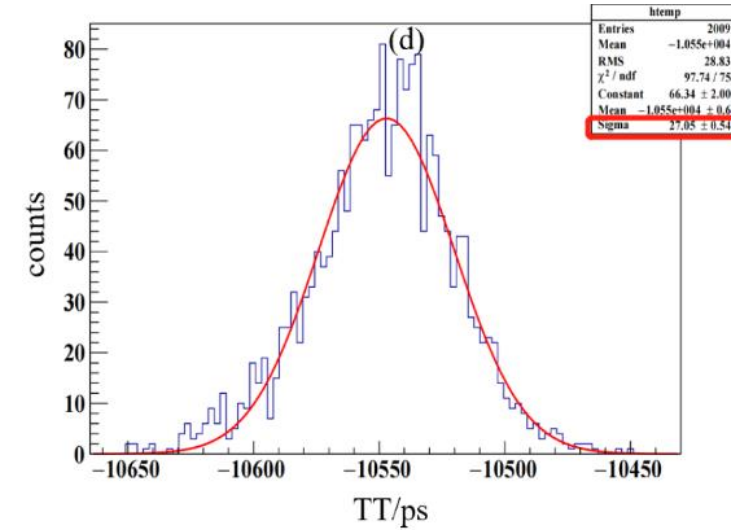

Transit-time spread (TTS) of 28 ps for the onsemi J-30035 SiPM.

*IEEE TRANSACTIONS ON NUCLEAR SCIENCE*, **68** (2021) 2096

# SiPM – radiation tolerance

## Characterisation of SiPM radiation hardness for application in hadron calorimeters at FAIR, CERN and NICA

Degradation becomes evident at neutron fluences above  $10^{11}$  n/cm<sup>2</sup> even for the best devices studied here.

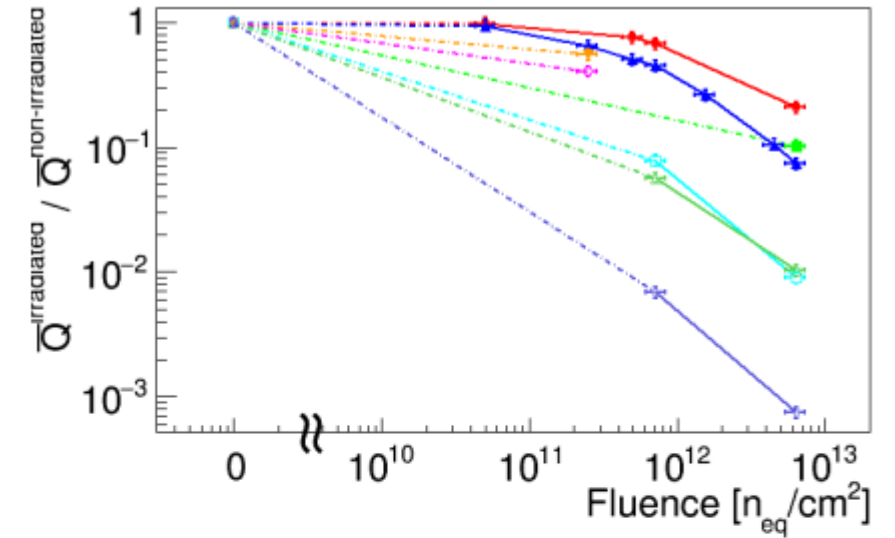

(a)

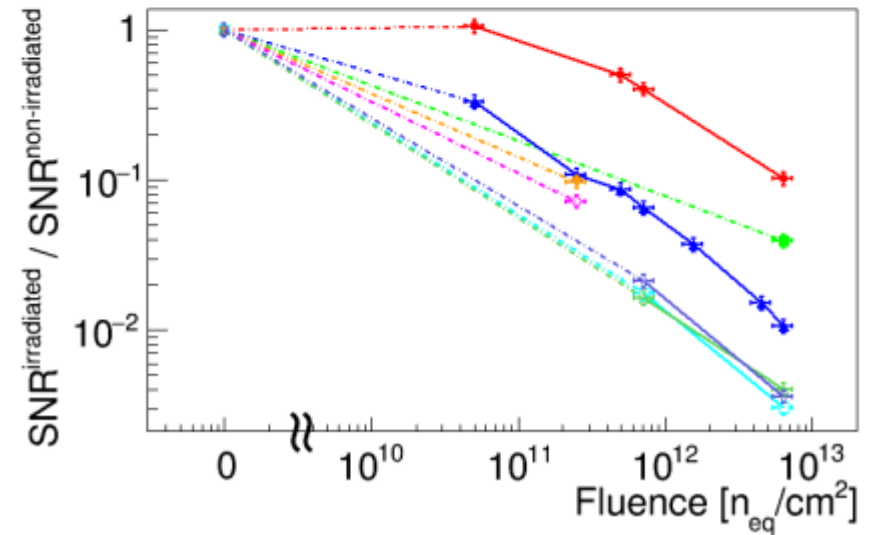

arXiv:2001.10322v1 [physics.ins-det] 28 Jan 2020

# SiPM – imaging devices

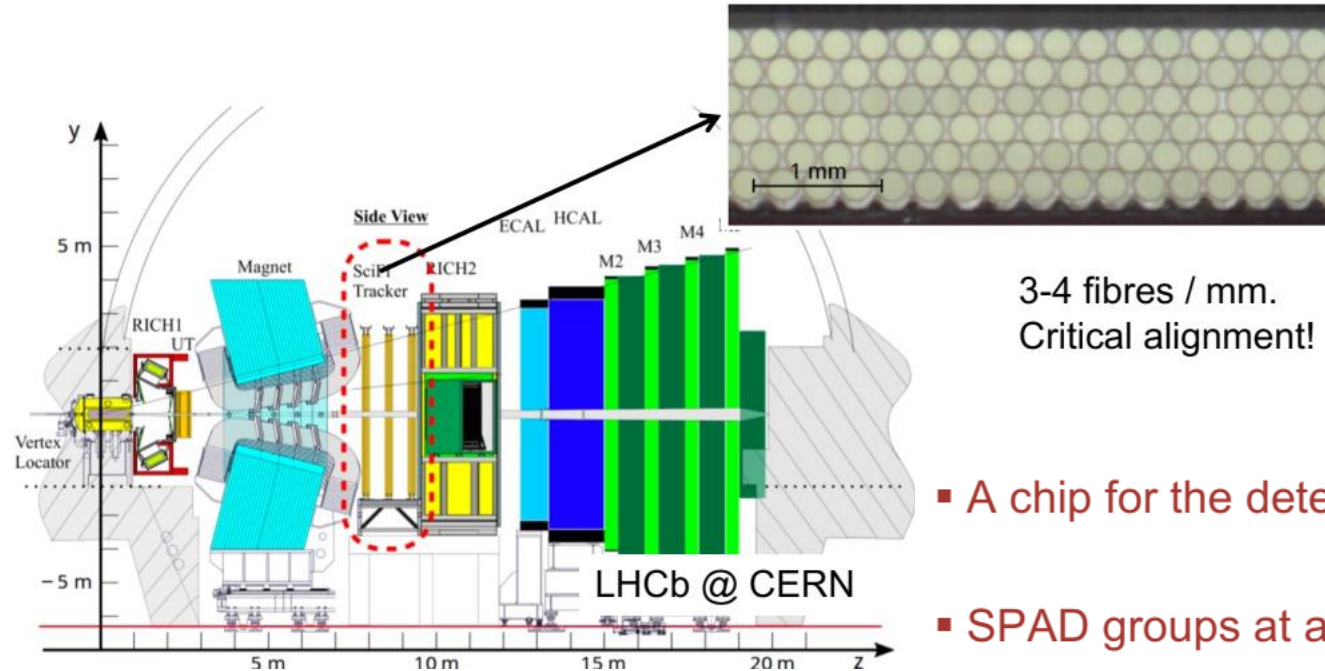

3-4 fibres / mm.  
Critical alignment!

Tracking detector using scintillating fibres in LHCb

SPAD = “Single Photon Avalanche Diode”

- A chip for the detection of photons in optical fibers has been designed
- SPAD groups at arbitrary positions can be defined in software
- Chip has purely digital outputs (pulse – width coded):
  - Event Time has a jitter of < 500 ps for small groups
  - Few photons can be clearly distinguished
  - Photon number of up to 30 are possible

# SiPM – imaging devices

## CMOS SPAD Sensor Chip for the Readout of Scintillating Fibers

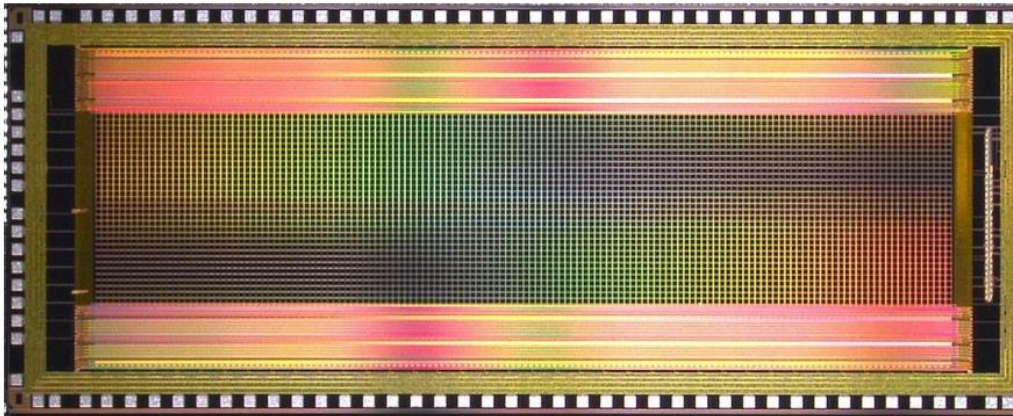

Prof. Dr. Peter Fischer, Benedict Maisano, Robert Zimmermann

Institute for Computer Engineering (ZITI) and Physics Institute (PI),  
Heidelberg University

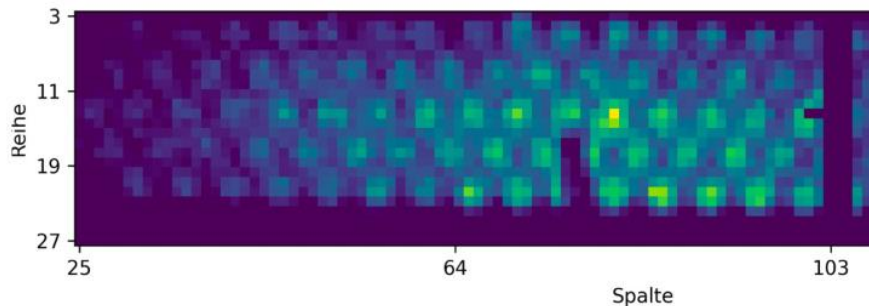

Dark Count Rate  
(measured on different chip)

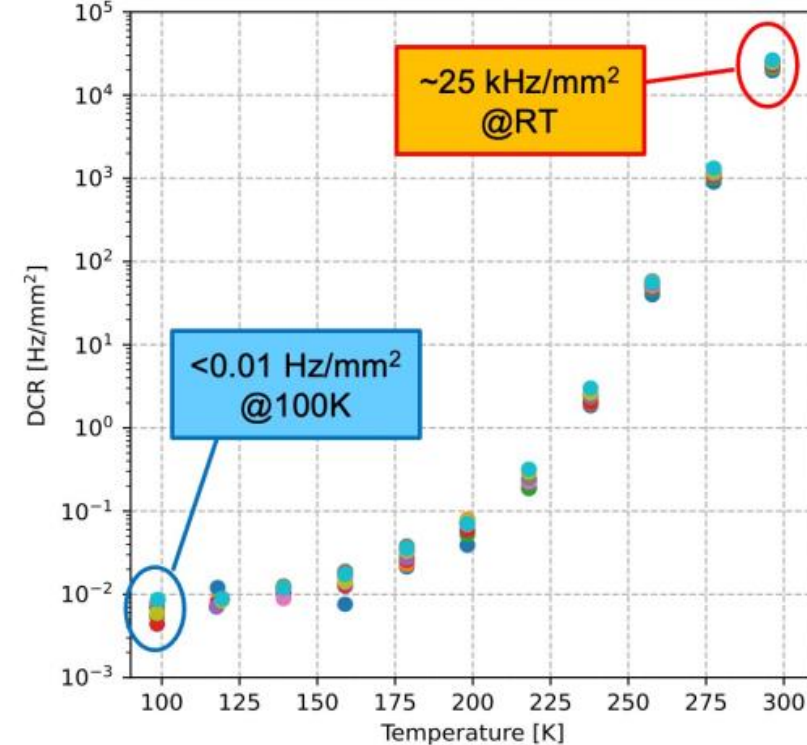

- Chip has purely digital outputs (pulse – width coded):
  - Event Time has a jitter of < 500 ps for small groups
  - Few photons can be clearly distinguished
  - Photon number of up to 30 are possible



# SiPM summary

## Pros:

|                                |                          |
|--------------------------------|--------------------------|
| High gain                      | [ $10^5$ to $10^7$       |
| Compactness                    | [ 1 to 3 mm <sup>2</sup> |
| Insensitive to magnetic fields | [ up to few T            |
| Low operation voltage          | [ 30 - 70 V              |

## Cons:

|                           |                              |   |
|---------------------------|------------------------------|---|
| Limited dynamical range   | [ $N_{\text{pxl}} = O(1000)$ | These parameters are being improved with the latest devices |
| Cross-talk, after-pulsing | [ 1-10%                      |   |
| High dark-rate            | [ 0.1 to few MHz             |   |
| Temperature sensitivity   | [ 20-50 mV/K                 |   |

# Photodetectors – the photomultiplier tube (PMT)

- A *free* electron is liberated from a *photocathode* (photoelectric effect) into a vacuum under an electric field
  - The free electron is accelerated to a few hundred volts and hits a *dynode*
  - Low energy ( $\sim 1\text{eV}$  each ) *secondary electrons* are liberated from the dynode (4 to 10 depending on electron energy and material of dynode)
  - Each secondary electron is accelerated and hits the next dynode
  - And so on ...
- A typical tube used in HEP has 10 to 14 dynodes
- Thus a **high gain** is achieved ( $10^5$  to  $\sim 10^7$ )
- A very special amplifier, with a **simultaneous high gain** ( $\sim 10^6$ ) and **high bandwidth** ( $\sim 1\text{GHz}$ ).
- **Large photosensitive areas** (up to hundreds of  $\text{cm}^2$ ) are possible, **but low QE** compared to silicon devices
- Most PMT are *very sensitive to magnetic fields*

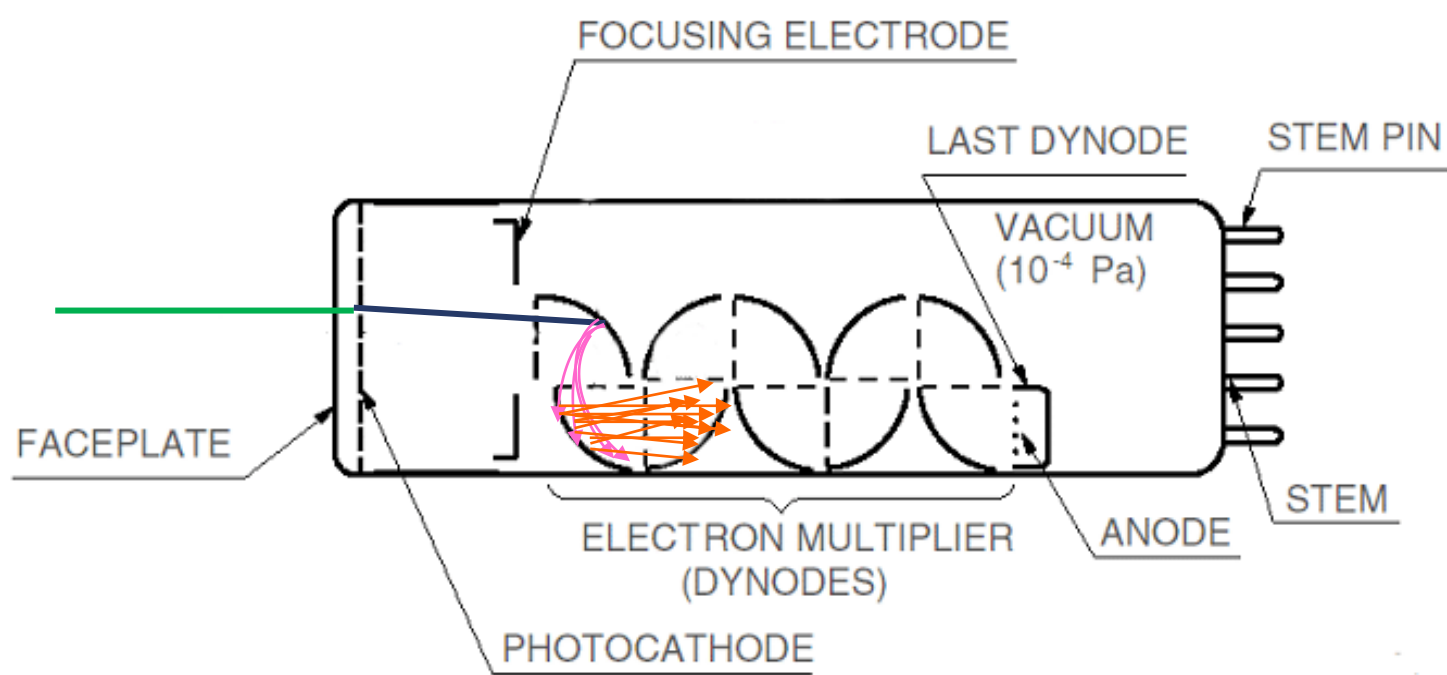

Typical dynode gain is about 4 (for BeCu dynodes) and a typical PMT has 10-12 dynodes. Current gain is therefore of order  $4^{10} \sim 1000000$ .



Michael Schmid / CC BY-SA (<http://creativecommons.org/licenses/by-sa/3.0/>)

# Fast large area PMT

Use electrostatic focussing to minimise the time differences from a large photocathode focussing onto a small area electron multiplier. Note use of a variety of electrodes. This type of PMT is very sensitive to external magnetic fields.

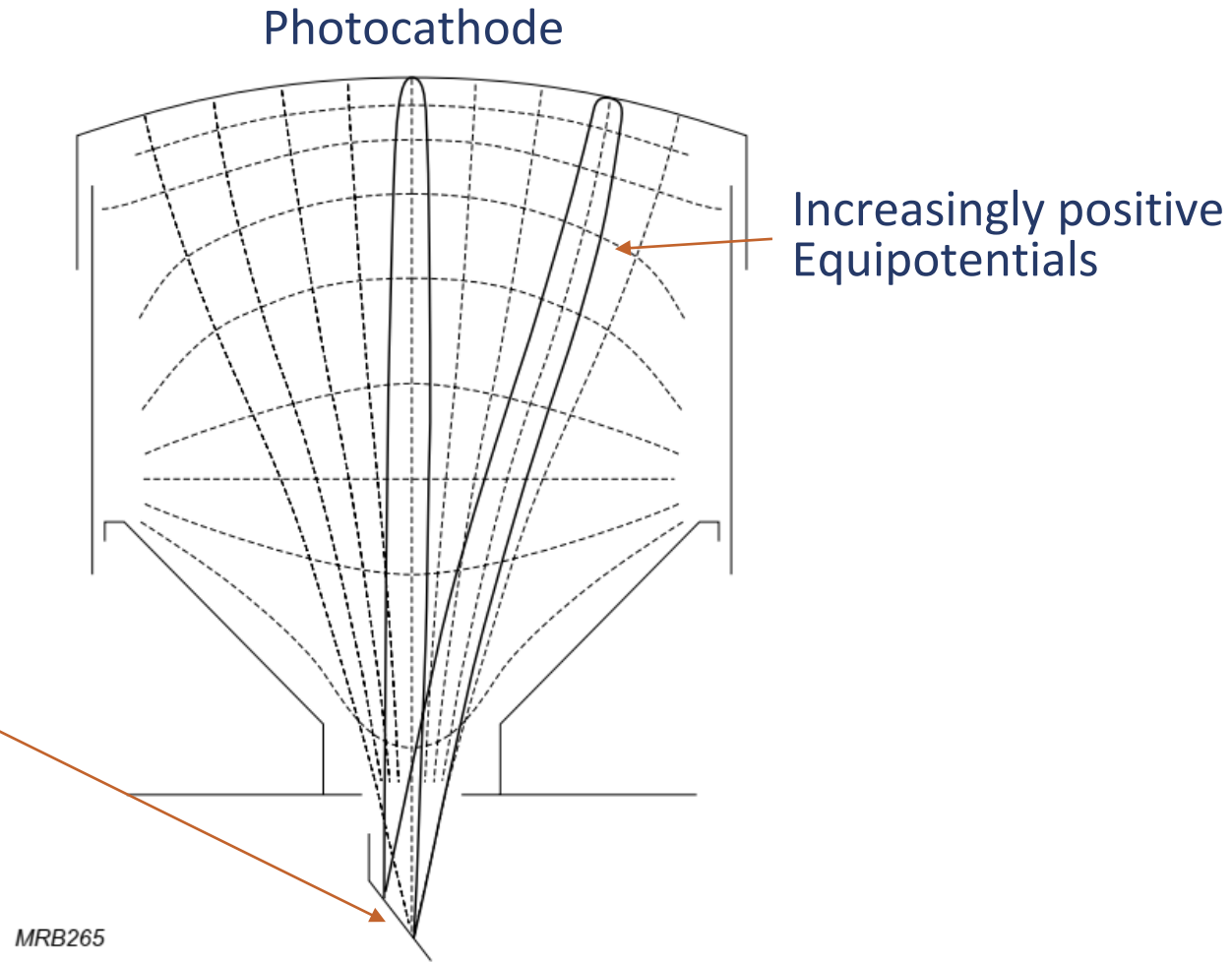

# Gain and noise

$G$  = gain

$I_{a0}$  = anode dark current (= noise!)

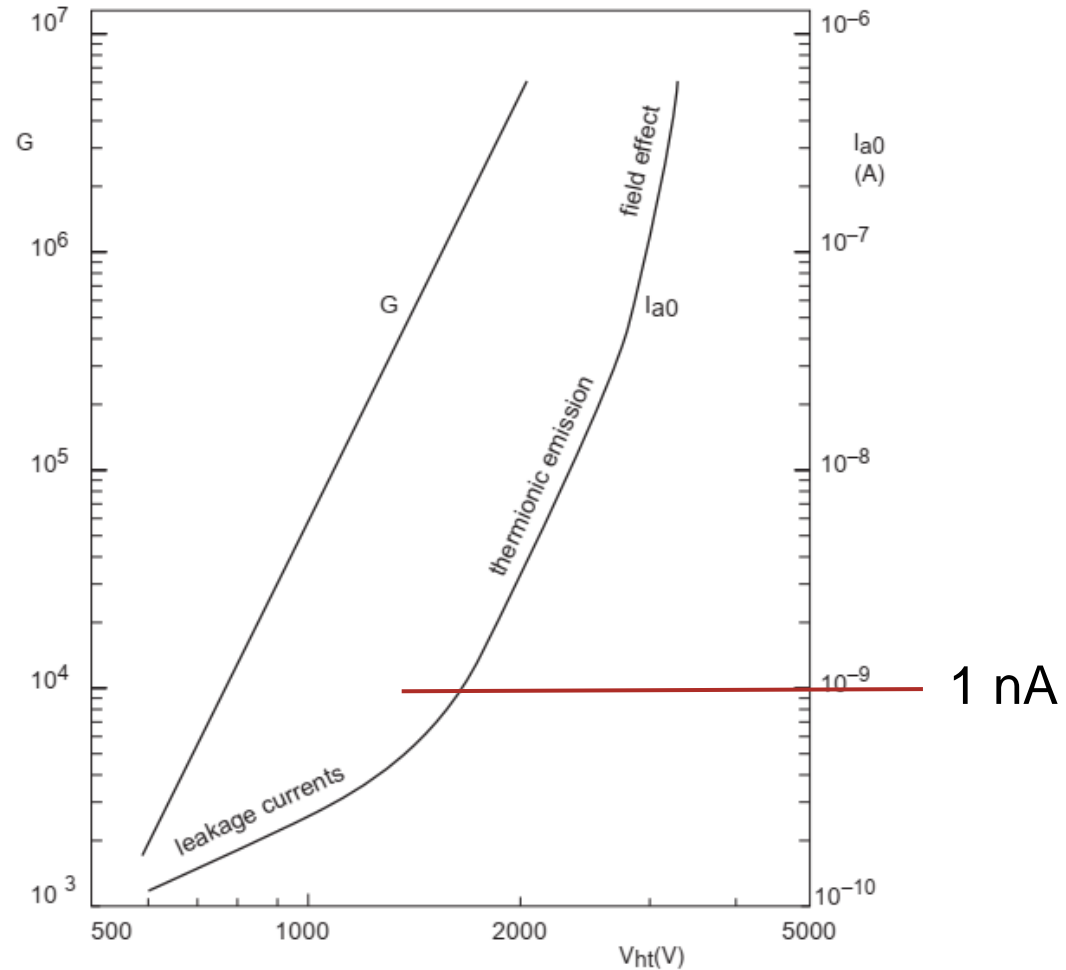

# Spectral response, dynode gain, noise

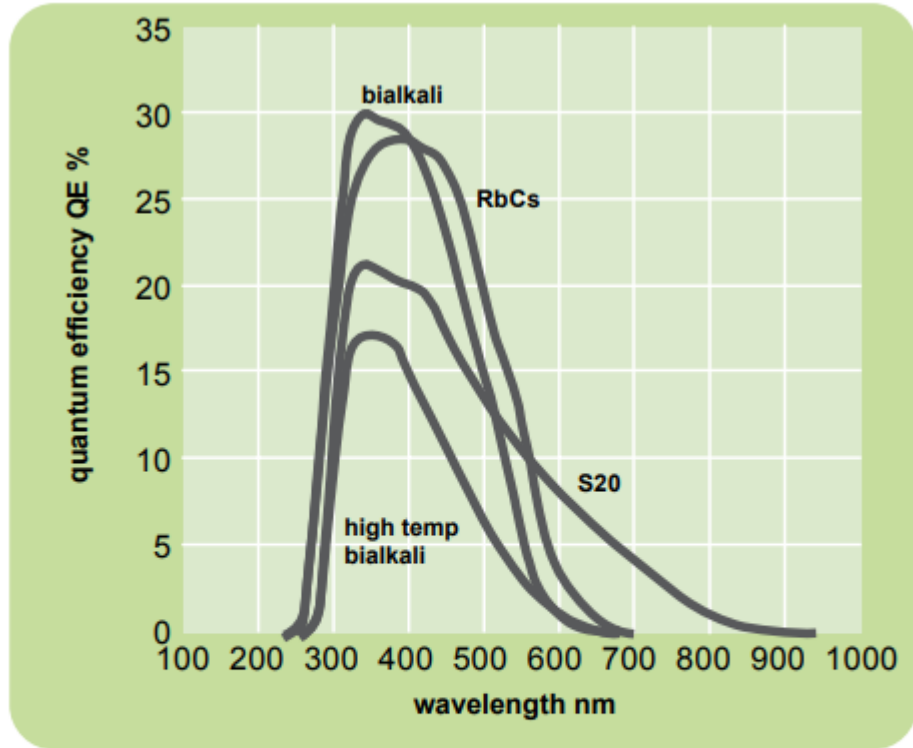

figure 4a Spectral response curves for various photocathodes deposited on borosilicate glass. The naming of photocathode types is historical. Measured values of QE against wavelength can be provided, at extra cost.

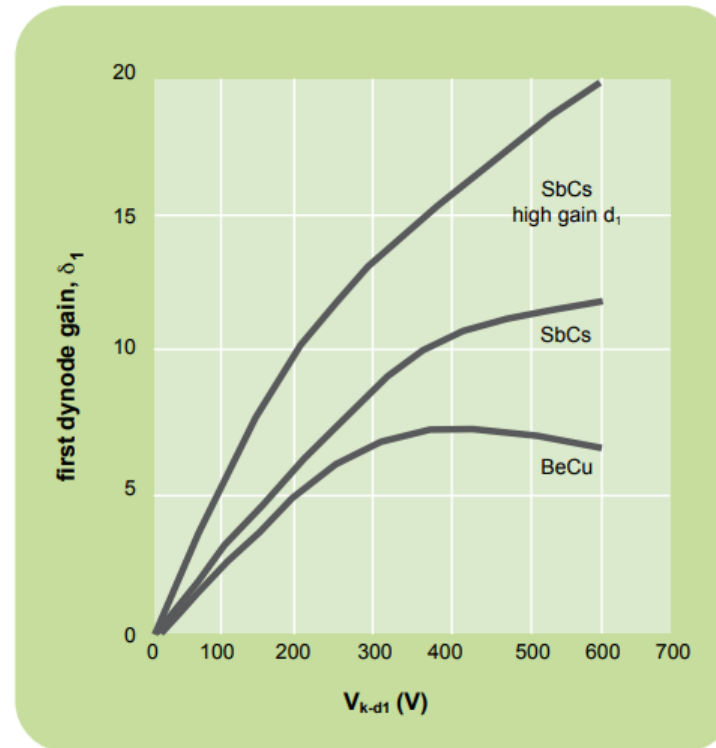
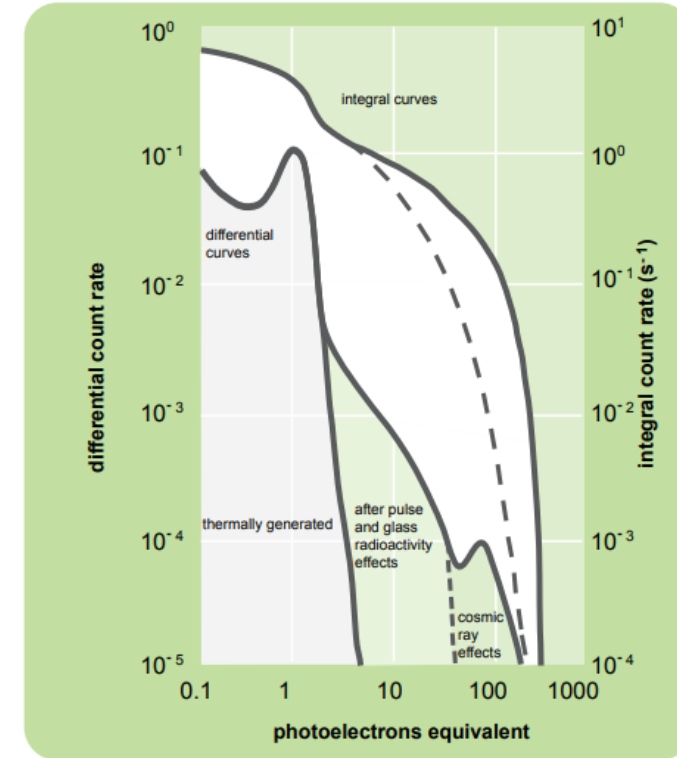

figure 9 Variation of first dynode gain,  $\delta_1$ , with  $k-d_1$  voltage.



Plots from ET Enterprises Limited, Uxbridge, UK

# Photomultipliers for high magnetic fields

Fine mesh dynode approach – gains in thousands, fields up to  $\sim 1\text{T}$

Fine mesh anode – gain  $\sim 10$  but operating at fields up to at least  $4\text{T}$

## Vacuum Phototriodes (VPT)

B-field orientation in end caps favourable for VPTs

(Tube axes  $0^\circ < |\theta| < 40^\circ$  with respect to field)

Vacuum devices offer greater radiation hardness than Si diodes

- Gain 8 - 10 at  $B = 4\text{T}$
- Q.E.  $\sim 20\%$  at  $420\text{ nm}$
- Insensitive to ionising particles
- UV glass window - much less expensive than quartz and much more radiation resistant than borosilicate glass
- Used in the current CMS endcap calorimeter at the LHC.

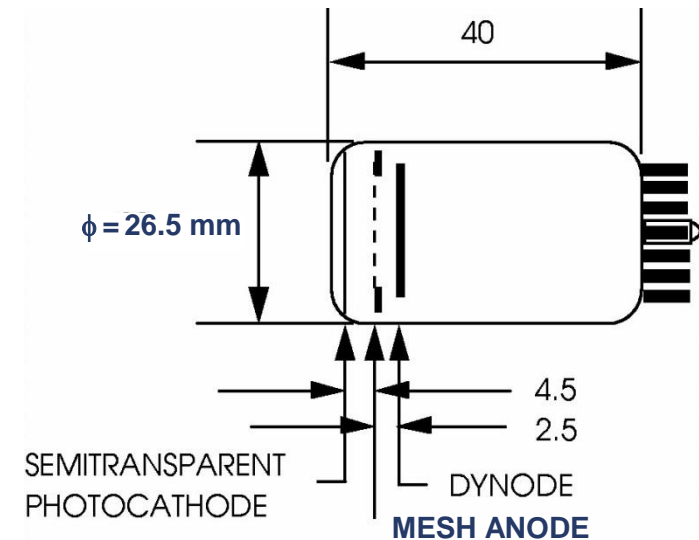

# Photomultipliers – VPT used in CMS

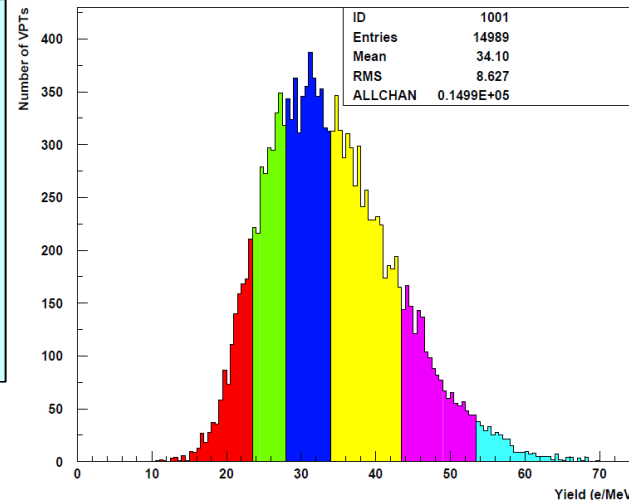
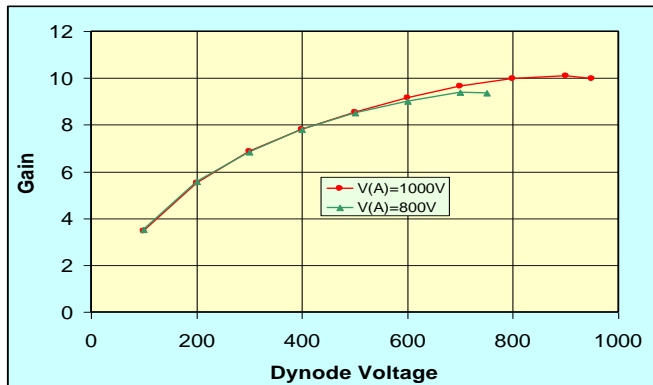
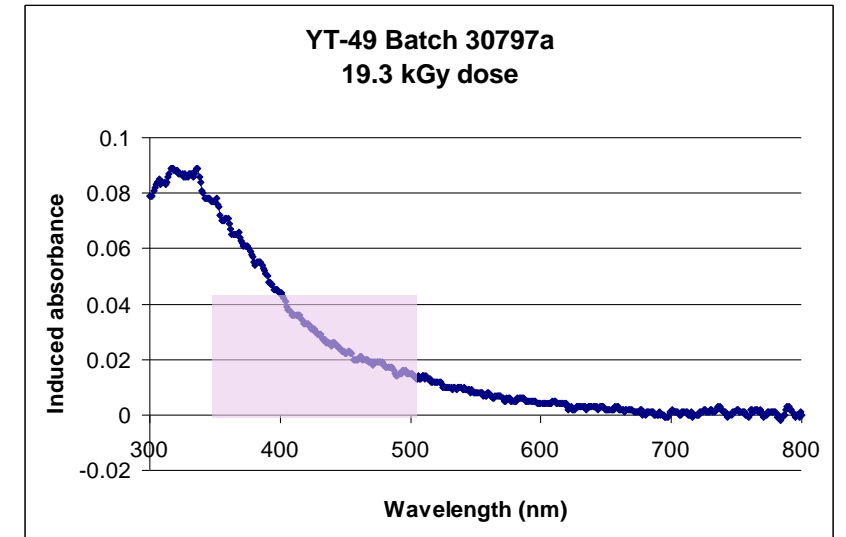
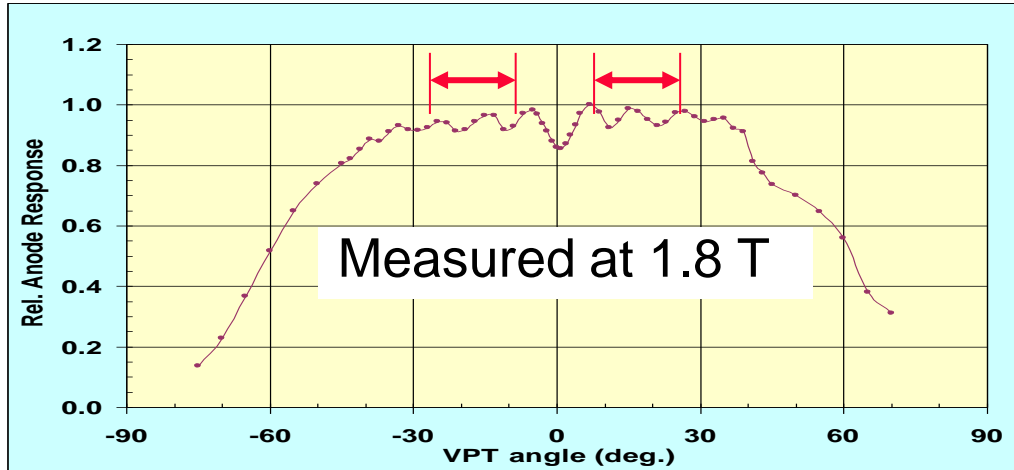

Variation in gain\*QE

Only 8% loss of transparency in the glass faceplate after 19 kGy radiation dose (equivalent to 10 years operation at LHC)

Violet box shows the extent of the  $\text{PbWO}_4$  scintillation spectrum which peaks at 430 nm.



# Photomultipliers are still being improved

Ultra-compact PMT from Hamamatsu

High QE photocathodes

## Micro PMT internal structure

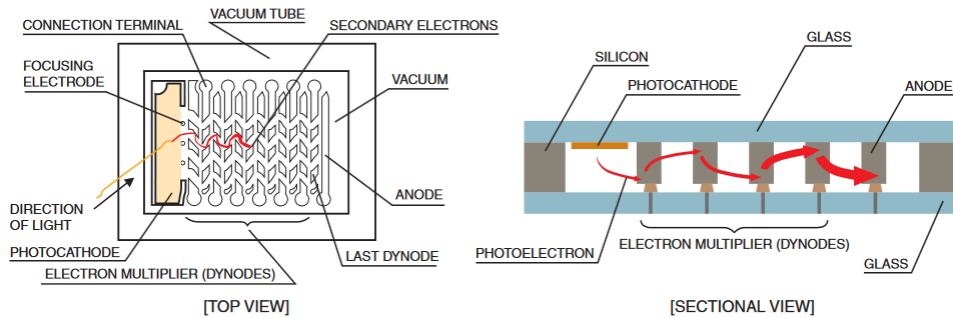

Gain  $\sim 10^6$ , rise time of anode pulse  $\sim 1$  ns, active area  $3 \text{ mm}^2$

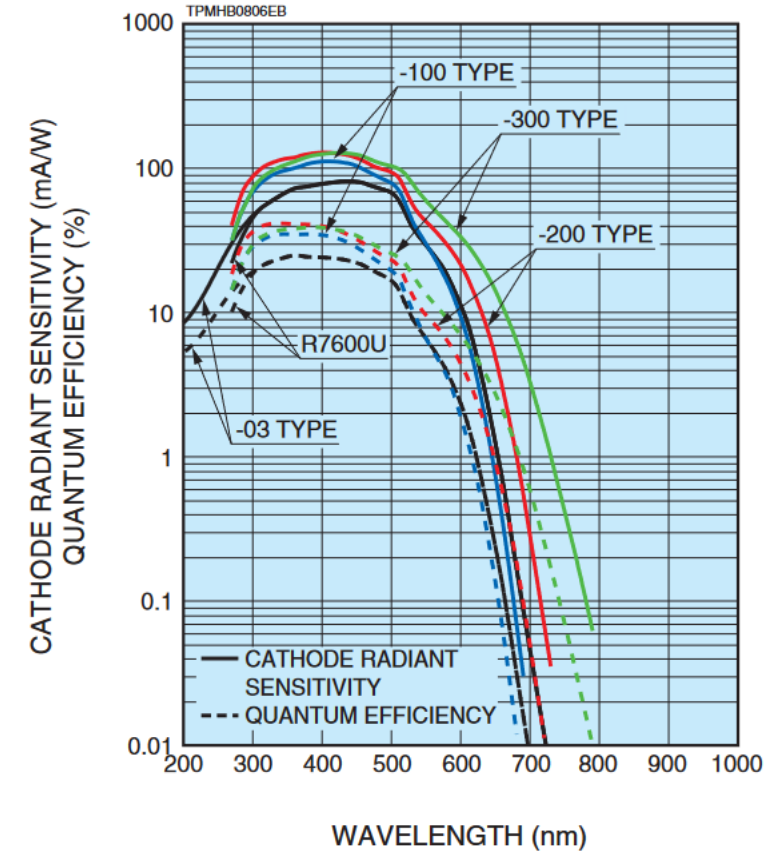
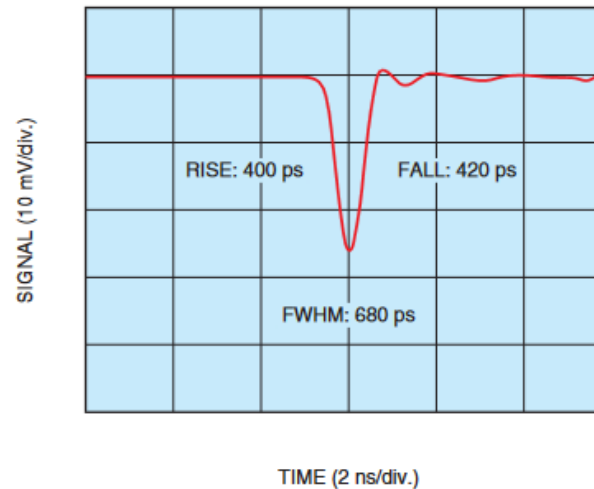

# Photomultipliers for many channels

Using proximity focus, and semi-transparent dynodes you can transfer, with gain, the localised photon signal on the photocathode to an array of anodes.

Hamamatsu have also developed a very compact “metal channel dynode” design that enables multi-anode capability. **This is very useful for reading out small area scintillating crystals used in PET scanners for medicine.**

Figure 5: Positioning Histogram Example

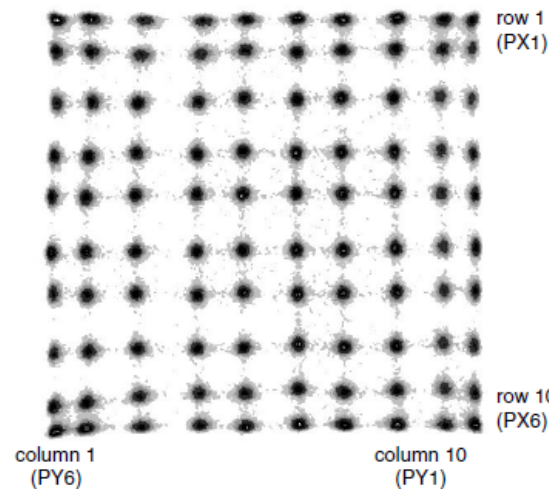
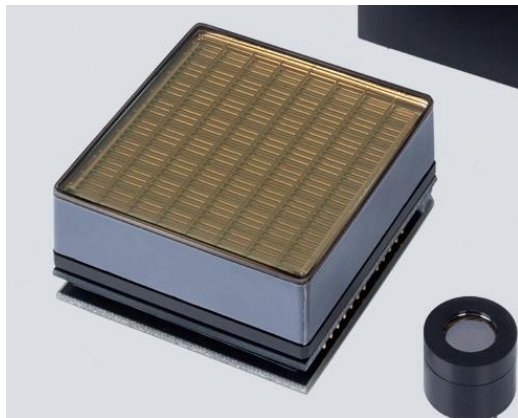

Positioning histogram of a  $10 \times 10$  array of  $2 \text{ mm} \times 2 \text{ mm} \times 20 \text{ mm}$  BGO elements for 511 keV  $\gamma$ -rays.

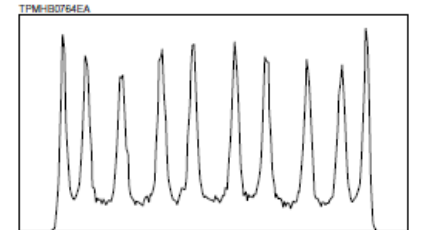

Positioning histogram profile for row 5 (left: column 1)

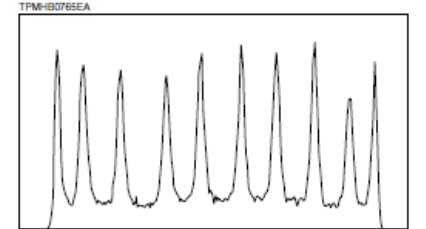

Positioning histogram profile for column 5 (left: row 10)

Hamamatsu R8900 6x6 anode PMT. Gain  $\sim 700000$  @ 1kV

# Micro Channel Plate (MCP)

## ➤ The Microchannel Plate MCP

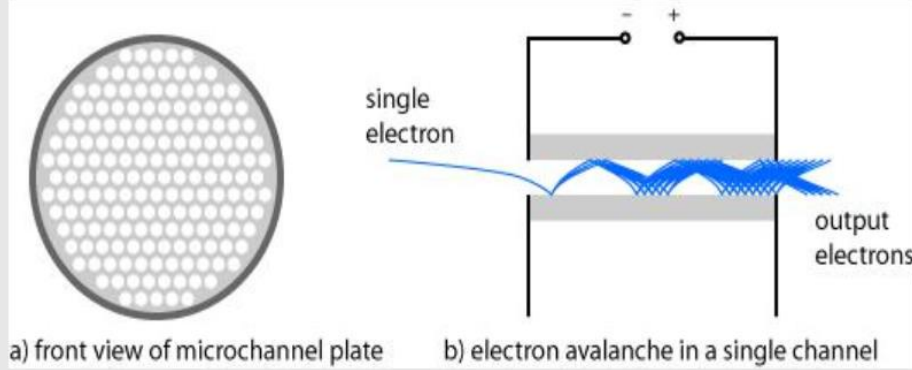

performance of the MCP:

- High Gain:  $1 \times 10^4 / 1 \text{ pic}$
- Small Size: Diameter=50mm
- Fast Signal: Rise time < 1ns
- TTS@SPE:  $\sim 30\text{ps}$

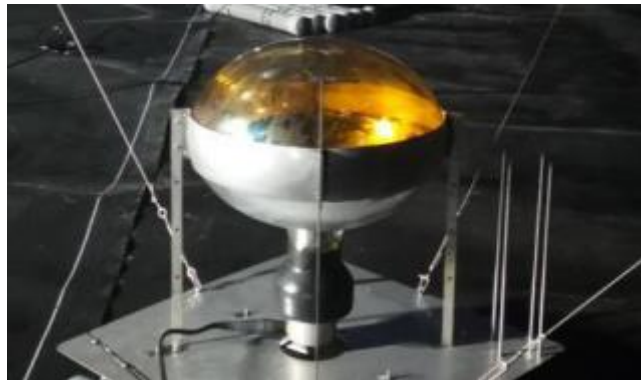
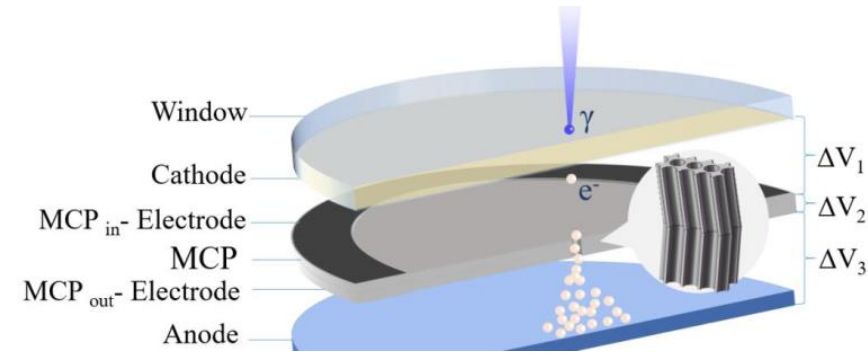

Built for LHAASO expt.  
Concept for  $4\pi$  detection!



- 1) Using two sets of Microchannel plates (MCPs) to replace the dynode chain
- 2) Using transmission photocathode (front hemisphere) and reflection photocathode (back hemisphere)

$\sim 4\pi$  viewing angle!

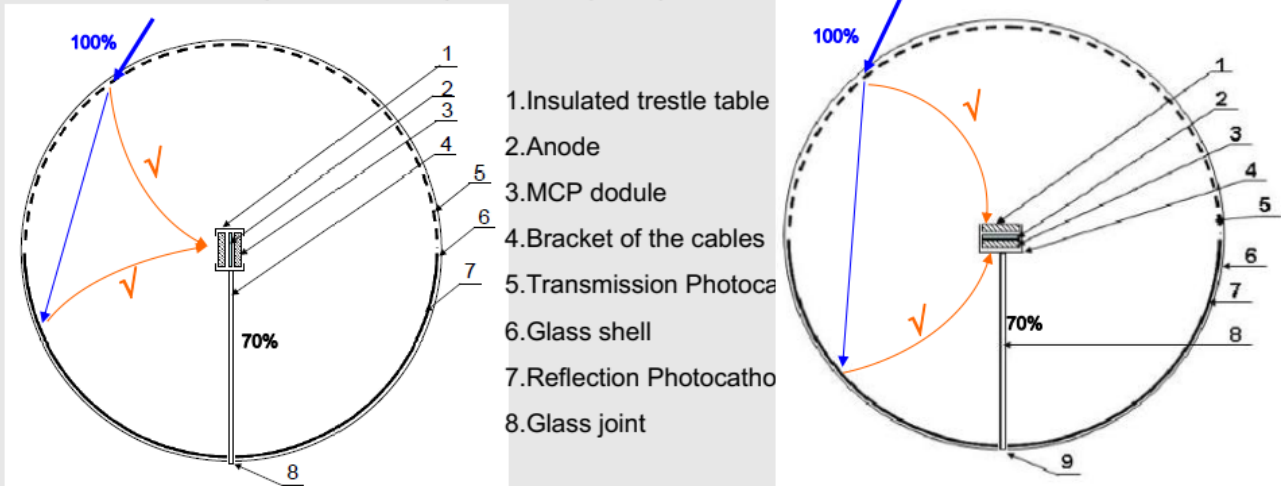

# Hybrid photodetector

- Generate free photoelectrons in a vacuum (like a photomultiplier tube)
- Accelerate photoelectrons to a high (10 to 20 kV) energy
- Use a silicon sensor as a *particle (electron) detector*. Get approximately 2500 eh-pairs for each photoelectron accelerated to 10 kV
- *Large* photocathode plus *small* area diode (low capacitance, thus fast)
- Use a pixel detector (CMOS) to provide a position sensitive photon counter.

# Hybrid photodetector

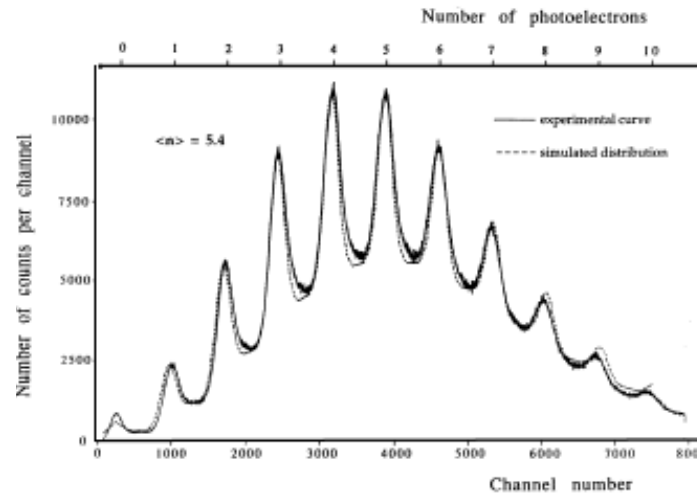
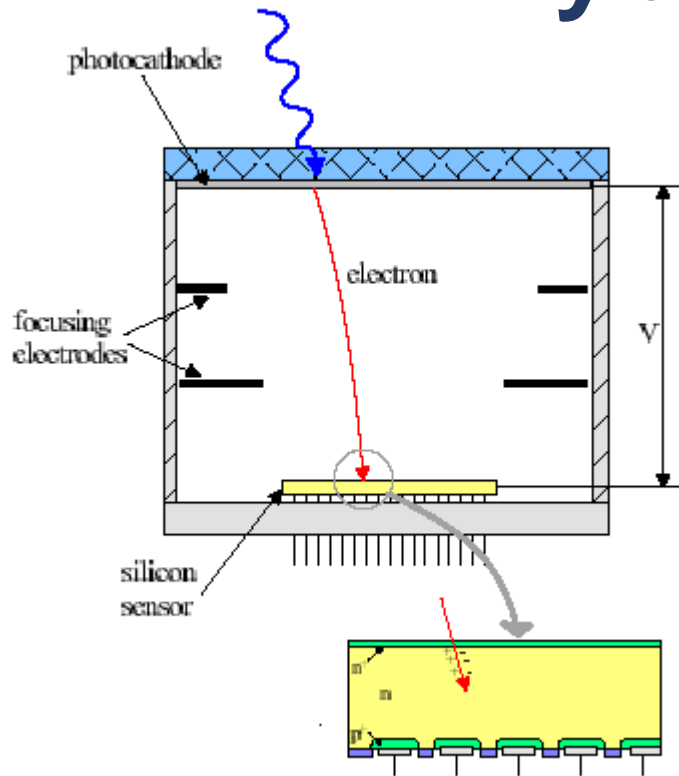

Note the resolution of 1,2,3,... photons.  $\langle n \rangle = 5.4$

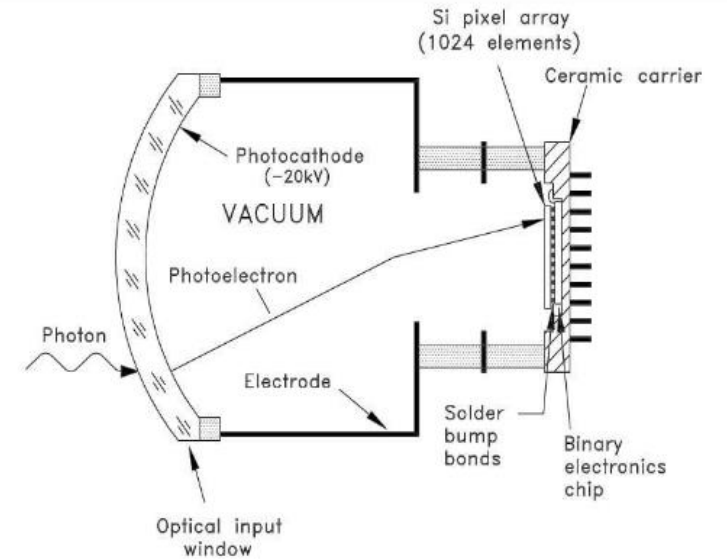

Used in the RICH of LHCb

C. Joram, CERN, *Large Area Hybrid Photodiodes*

6th International conference on advanced technology and particle physics, Como, Italy, October 5-9, 1998

See [lhcb-doc.web.cern.ch/lhcb-doc/presentations/conferencetalks/postscript/1998presentations/como.pdf](http://lhcb-doc.web.cern.ch/lhcb-doc/presentations/conferencetalks/postscript/1998presentations/como.pdf)

# Hybrid photodetector

Proximity  
focussed

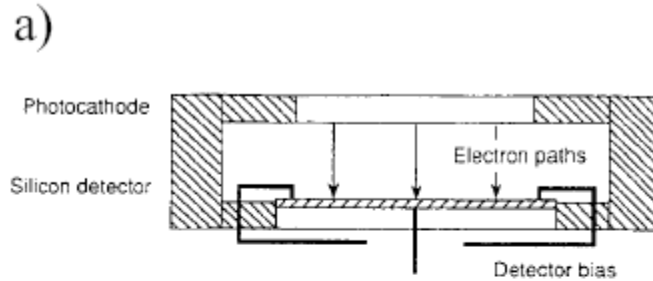

Cross  
focussed

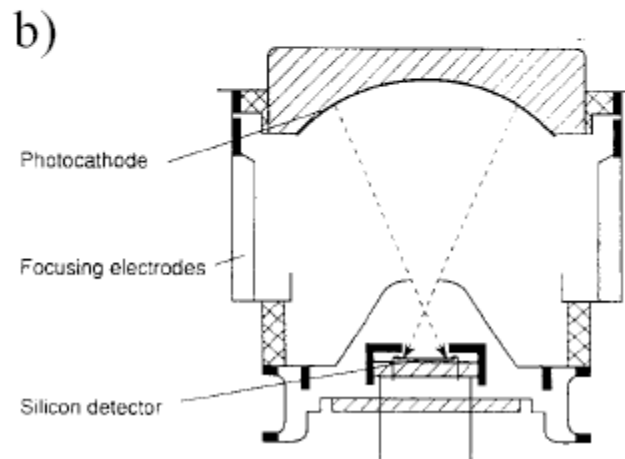

Used today with APD for ultrafast single-photon timing applications

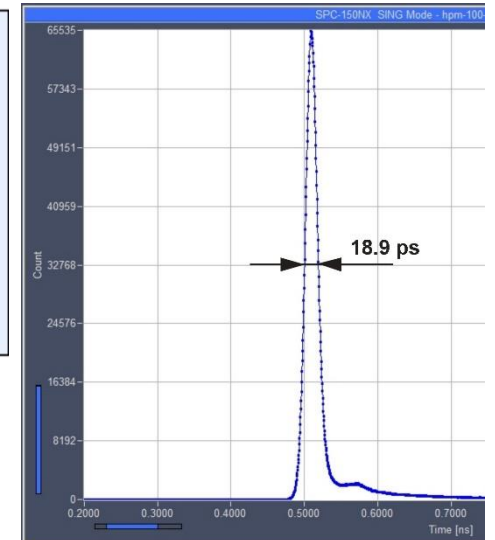
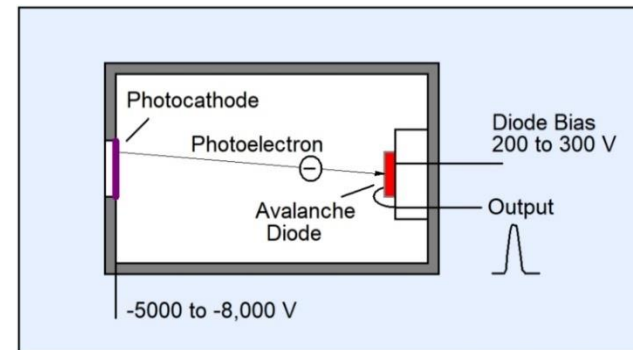

C. Joram, CERN, *Large Area Hybrid Photodiodes*  
6th International conference on advanced technology and particle physics, Como, Italy, October 5-9, 1998

Beckler & Hickl device with 6 mm diameter photocathode

# Advantages and disadvantages of PMT

High gain and large electrical bandwidth, fast **and** high rate possible.

Large photocathode areas are available. —————→

Insensitive to ionising radiation generating a signal (**but Cherenkov in faceplate**).

Very low dark count obtainable even at 293 K.

Very well understood technology.

Low noise at high(ish) temperatures (up to 200 °C for oil-well applications)

**Few manufacturers available (effectively two).**

**Low peak QE (~ 25%) compared to silicon devices (but improving).**

**Poor photocathode response in the red/near-IR**

**Does not compete with Geiger mode diodes for multi-photon counting.**

**Susceptible to gamma radiation induced darkening of faceplate (except quartz)**

**Sensitive to helium ingress – after-pulsing issues.**

**Handcrafted aspect for some tubes = £££**

**Uses high voltage (1 to 2 kV).**



Hamamatsu R12860,  
508 mm diameter  
PMT