



Medical applications and dosimetry





What I will cover

- Radiotherapy (the area most often contributed to by physicists)
 - Background and timeline of key innovations
 - External vs internal radiotherapy
 - Radiation interactions with matter: photons or protons?
 - Beam delivery technology
 - Imaging and range uncertainties*
 - Monitoring and dosimetry instrumentation*

*including some examples of measurements made with HEP detectors

What I won't cover

- Topics unrelated to radiotherapy: lasers, ultrasound imaging, prosthetics, drugs
- Radioisotope production and PET (maybe next year)
- Monte Carlo modelling and machine learning techniques (maybe next year)
- Radiobiology (maybe next year)





Who cares?



You should!

- Medical applications might seem peripheral to HEP instrumentation but it actually contains interesting physics too (cf lecture on radiation interactions with matter in this series: <https://indico.cern.ch/event/1277888/timetable/#13-interaction-of-particles-wi>)
- Normal people (read: non-physicists) may ask what the point of your research is. At least one answer to this question is to point out applications of your research to things widely regarded as problems. So application of detectors to e.g. radiotherapy helps with science communication
- Many physics students (some after PhD) will complete the NHS medical physics STP course to become medical physicists -> seems to be a popular career path for physics graduates - at least in the UK





X-ray Has Come a Long Way in 100 Years

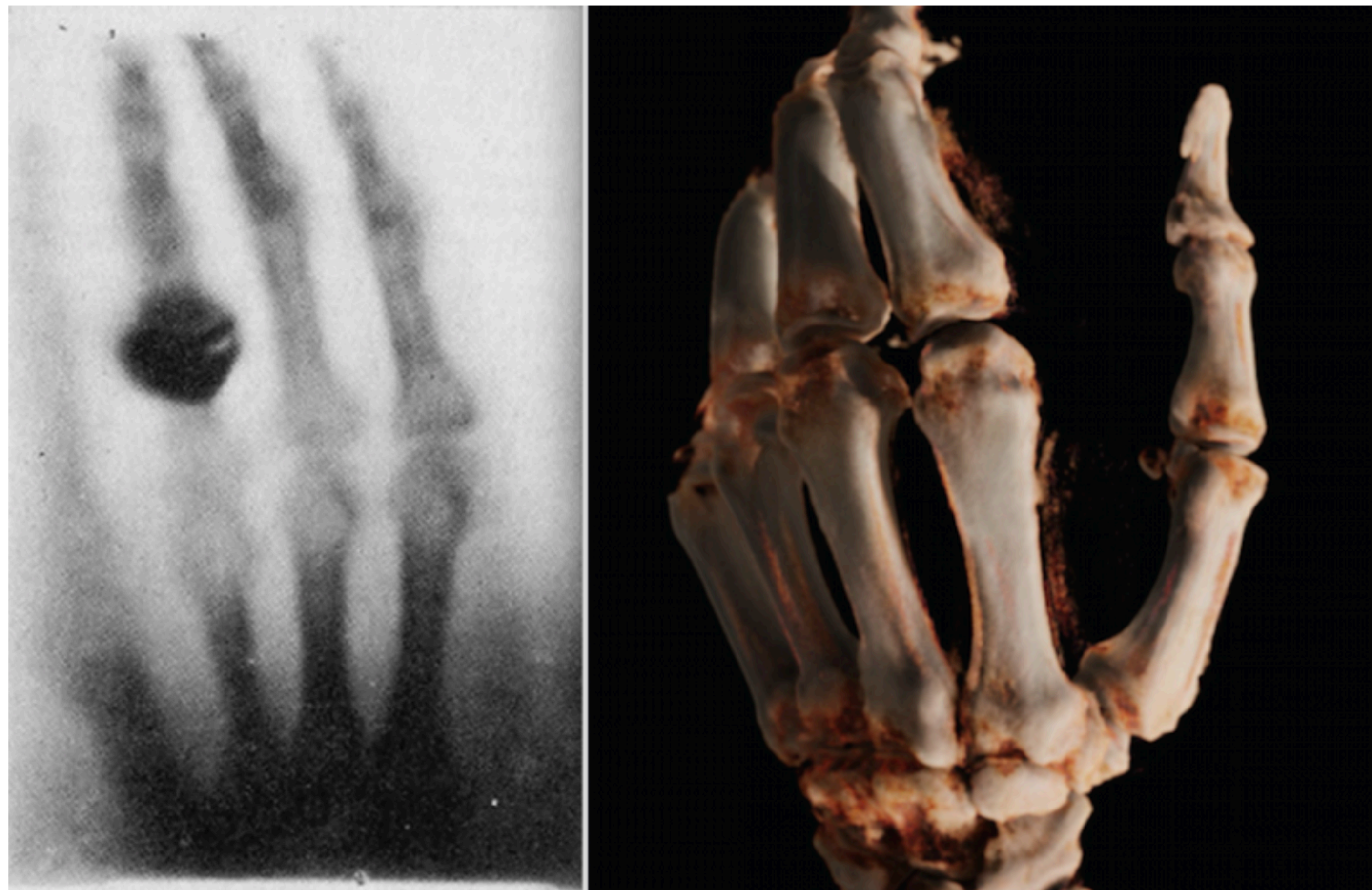

Left, the first X-ray ever made of Roentgen's wife's hand in 1895.

Right, a cone-beam CT 3-D reconstruction of a hand in 2015 using a new robotic digital radiography (DR) X-ray system.

<https://www.itnonline.com/content/blogs/dave-fornell-itn-editor/x-ray-has-come-long-way-100-years>





Timeline of radiotherapy with x-rays

Timeline 1 | Early landmark discoveries in radiotherapy

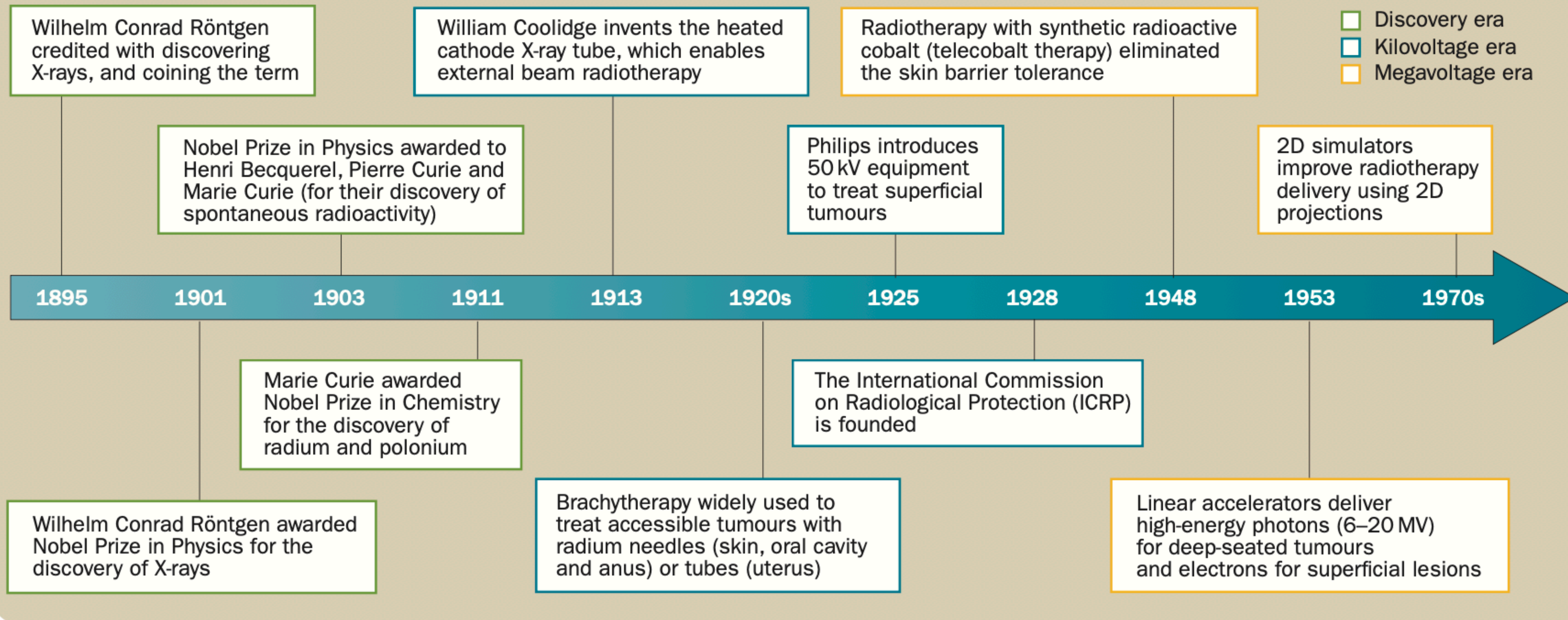

Timeline of innovations in x-ray radiotherapy: <https://doi.org/10.1038/nrclinonc.2012.203>





Comparison of radiotherapy modalities with time

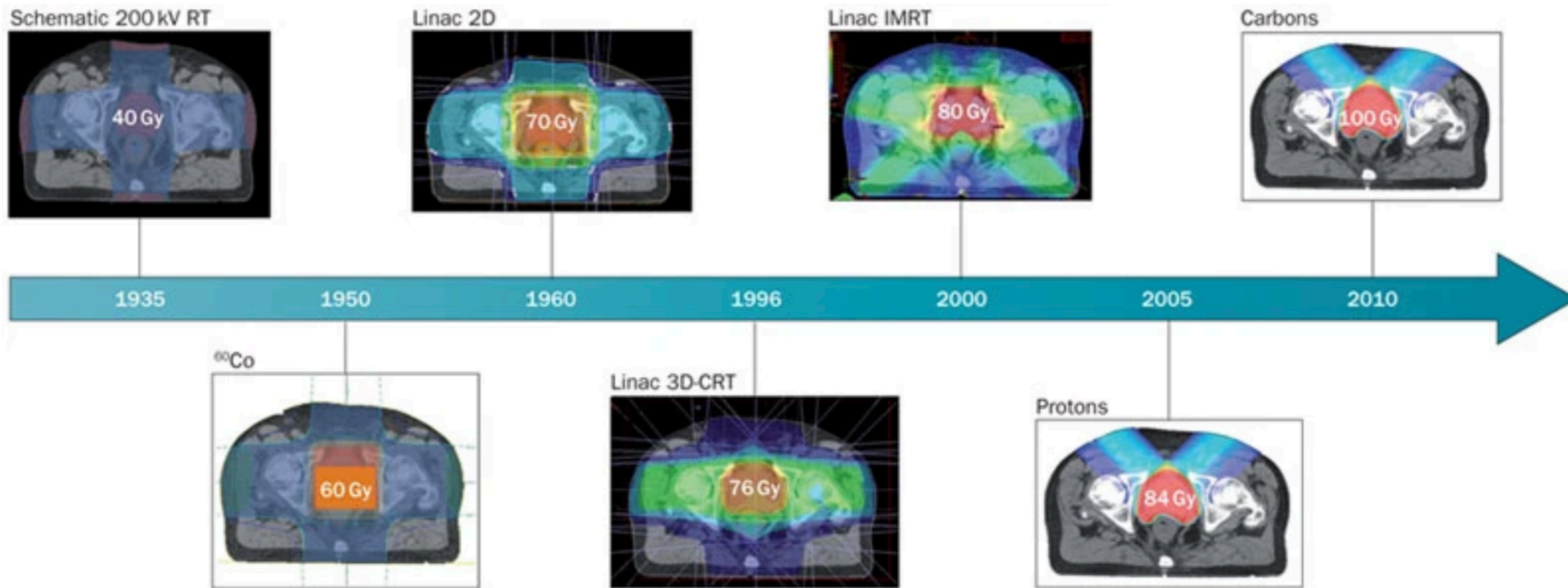

“Prostate cancer irradiation is a good example of the improvement of radiotherapy technology over the past decades. By increasing the beam energy and the precision of the targeting, it was possible to escalate the dose to the prostate without exceeding the tolerance dose of healthy tissues; allowing the move from palliative irradiation to curative treatment.” <https://doi.org/10.1038/nrclinonc.2012.203>





External vs internal radiotherapy

Radiotherapy with an external beam of x-rays from a rotating linac. Typical patient throughput can be ~100 / week



Rutherford Cancer Centre Liverpool

Brachtherapy with ^{125}I wires, low energy gamma / x-rays that only damage nearby (cancerous) cells

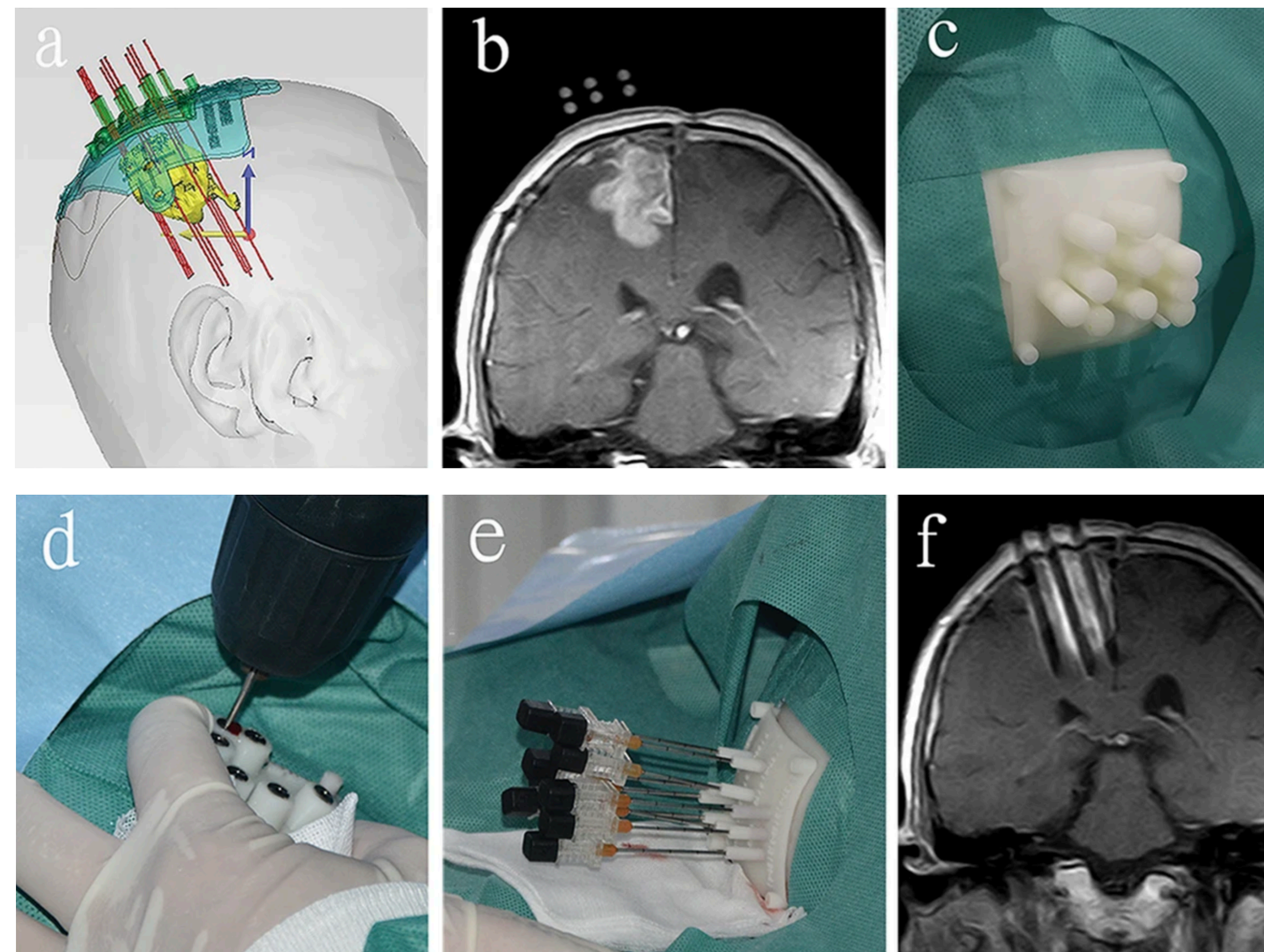

The procedure of 3DNPT combined with MR-guided ^{125}I brachytherapy for recurrent glioblastoma. <https://ro-journal.biomedcentral.com/articles/10.1186/s13014-020-01586-4>





Charged particle radiotherapy

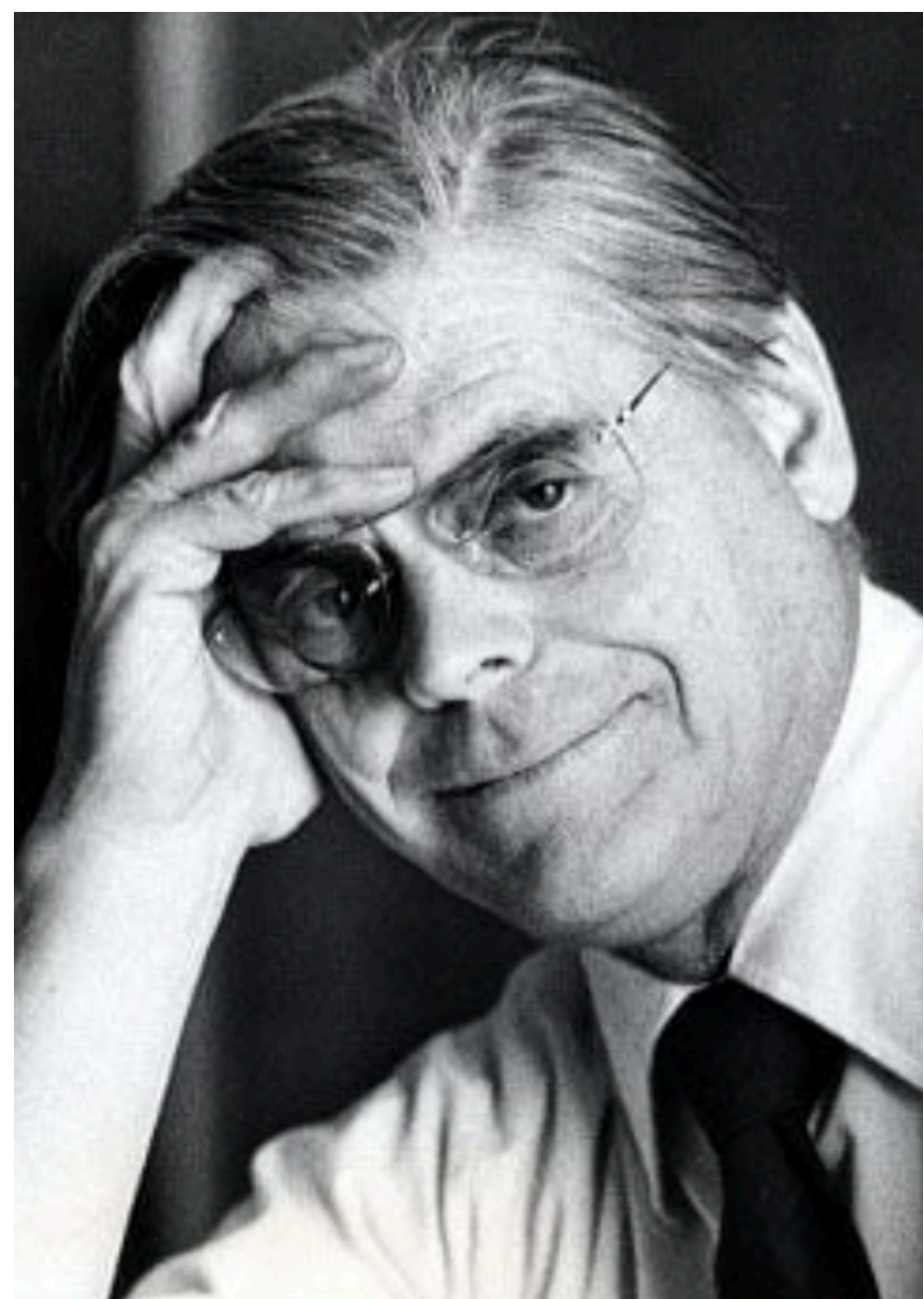

Robert R Wilson, the father of proton therapy c. 1950



Construction of the 184-inch synchrocyclotron at the Radiation Laboratory at the University of California, Berkeley, USA 1942. This cyclotron was developed by the laboratory's director Ernest Orlando Lawrence.

Ernest O. Lawrence and his associates were the first to invent the cyclotron in 1929 & developed it as a particle accelerator during the 1930s, winning the 1939 Nobel Prize for physics for this work. In 1931, he founded the Radiation Laboratory, later named the Lawrence Berkeley Laboratory (*Figure 1*). A decade later, his advanced version of the synchrocyclotron, which is 184 inches in diameter, is capable of producing 340 MeV protons

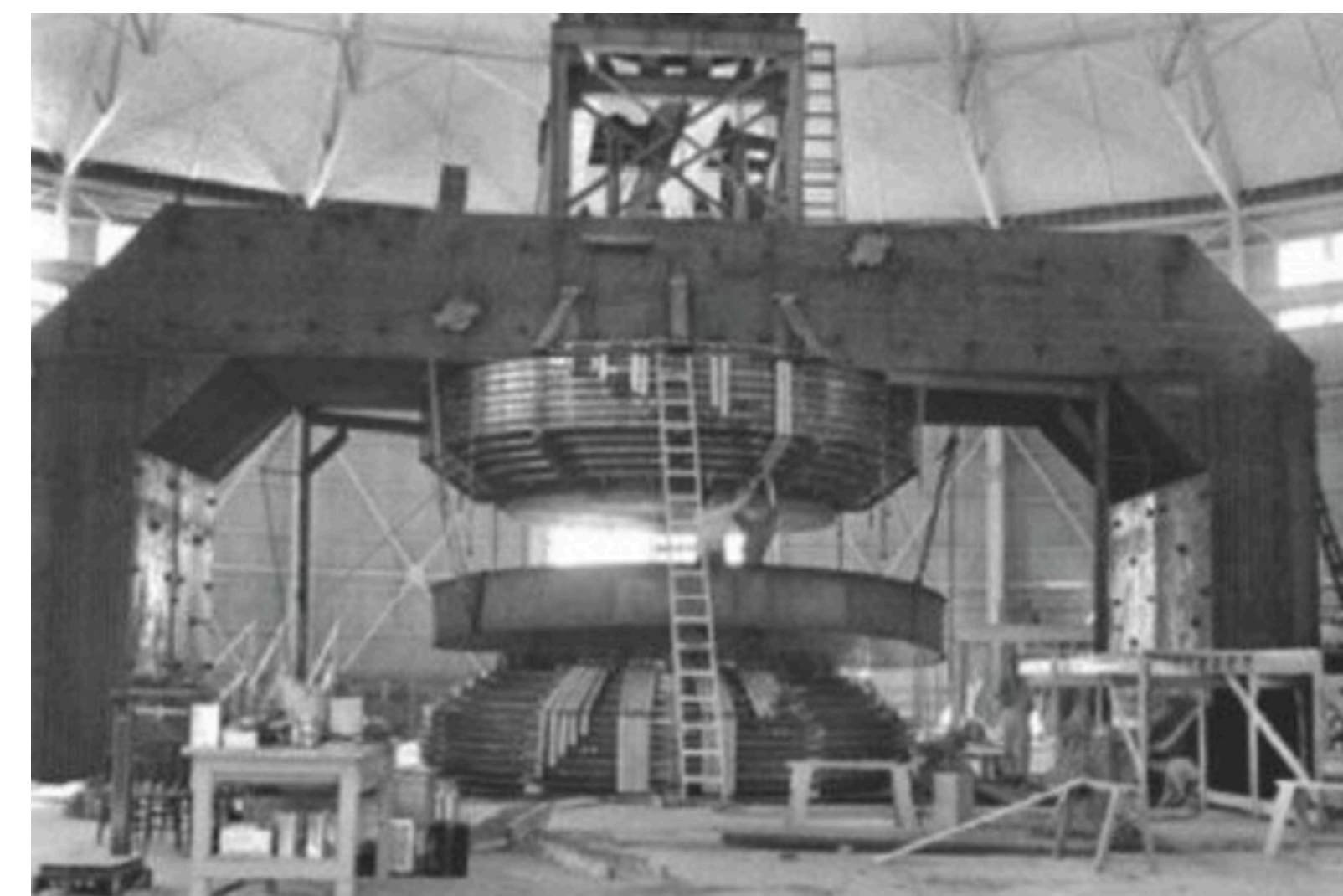

Photons vs protons

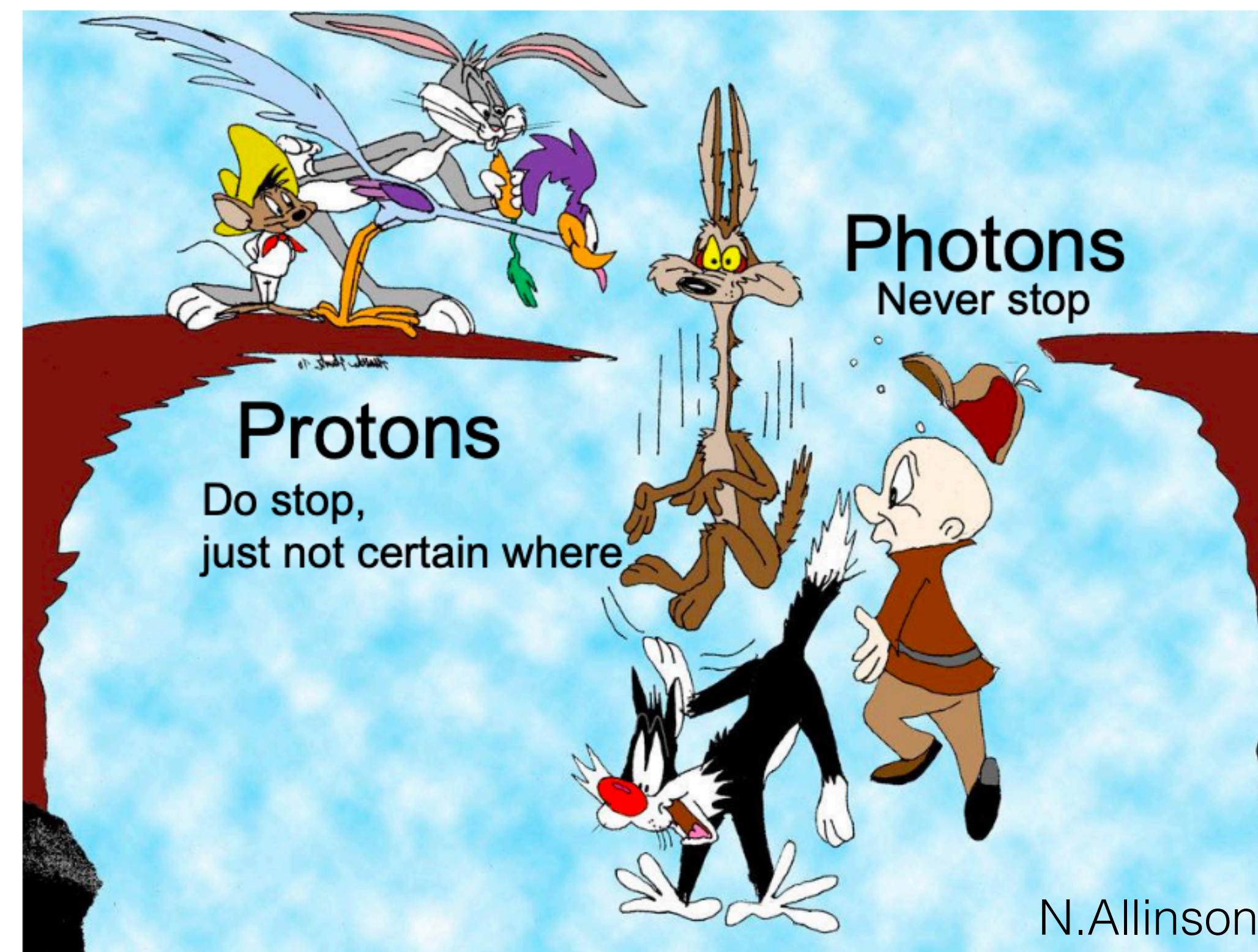
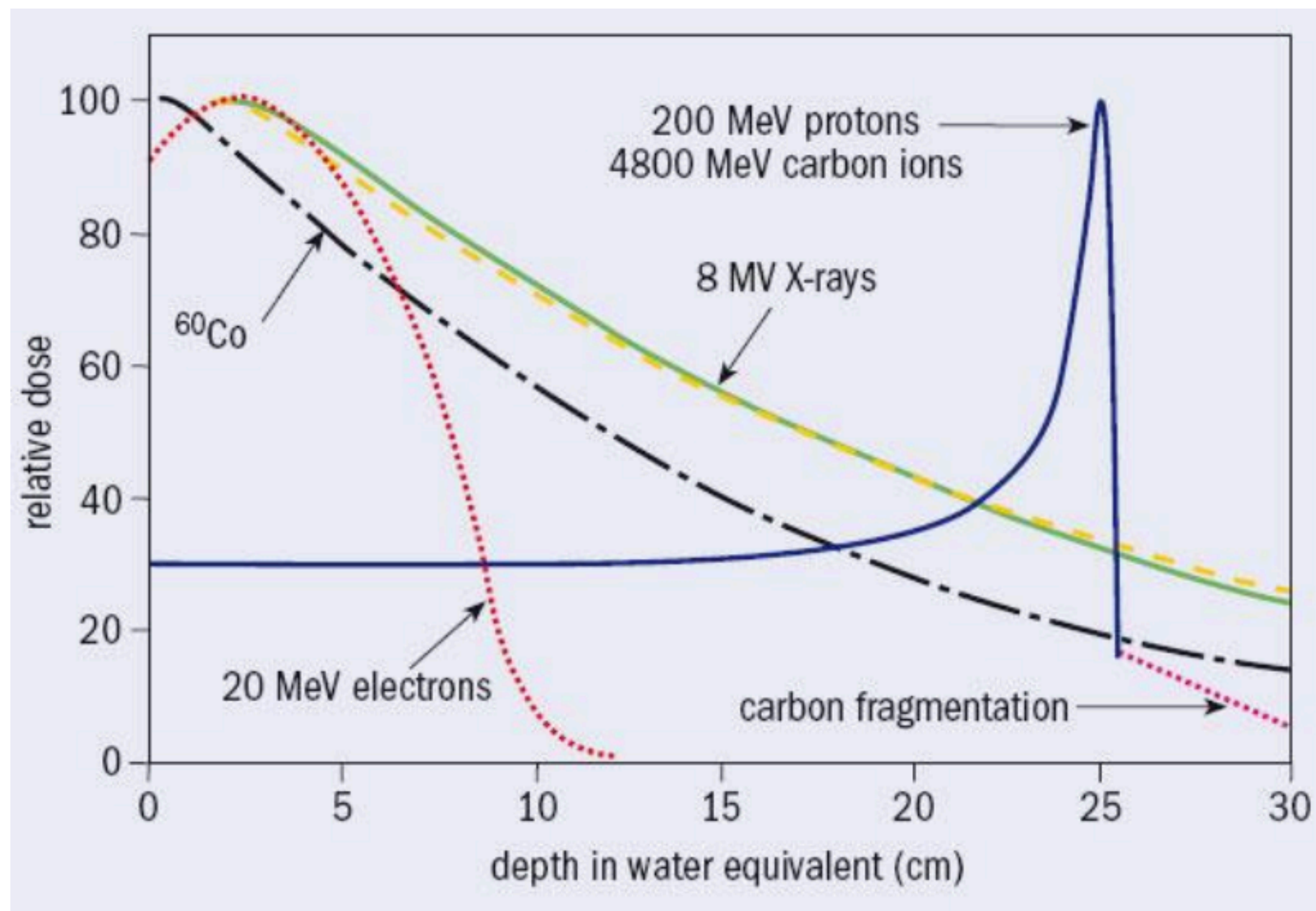

$$-\frac{dE}{dx} = \frac{4\pi}{m_e c^2} \cdot \frac{nz^2}{\beta^2} \cdot \left(\frac{e^2}{4\pi\epsilon_0}\right)^2 \cdot \left[\ln \left(\frac{2m_e c^2 \beta^2}{I \cdot (1 - \beta^2)} \right) - \beta^2 \right]$$

The advantage is the disadvantage

Photons vs protons

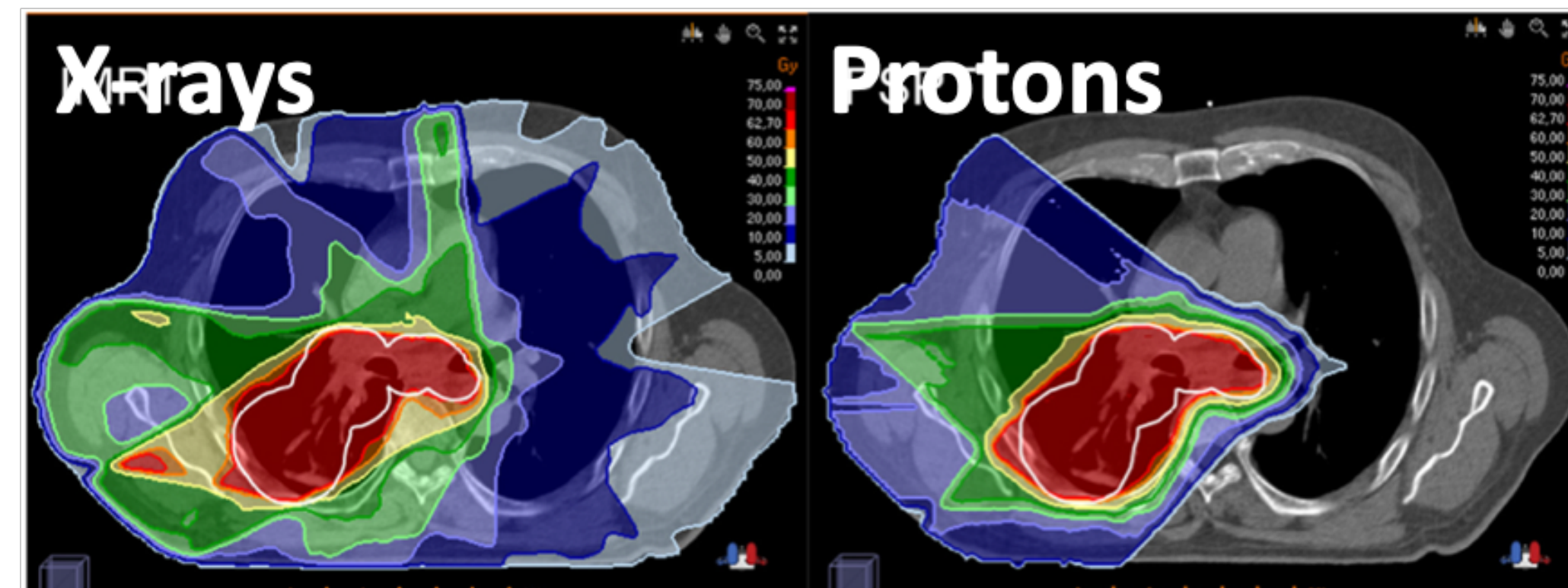
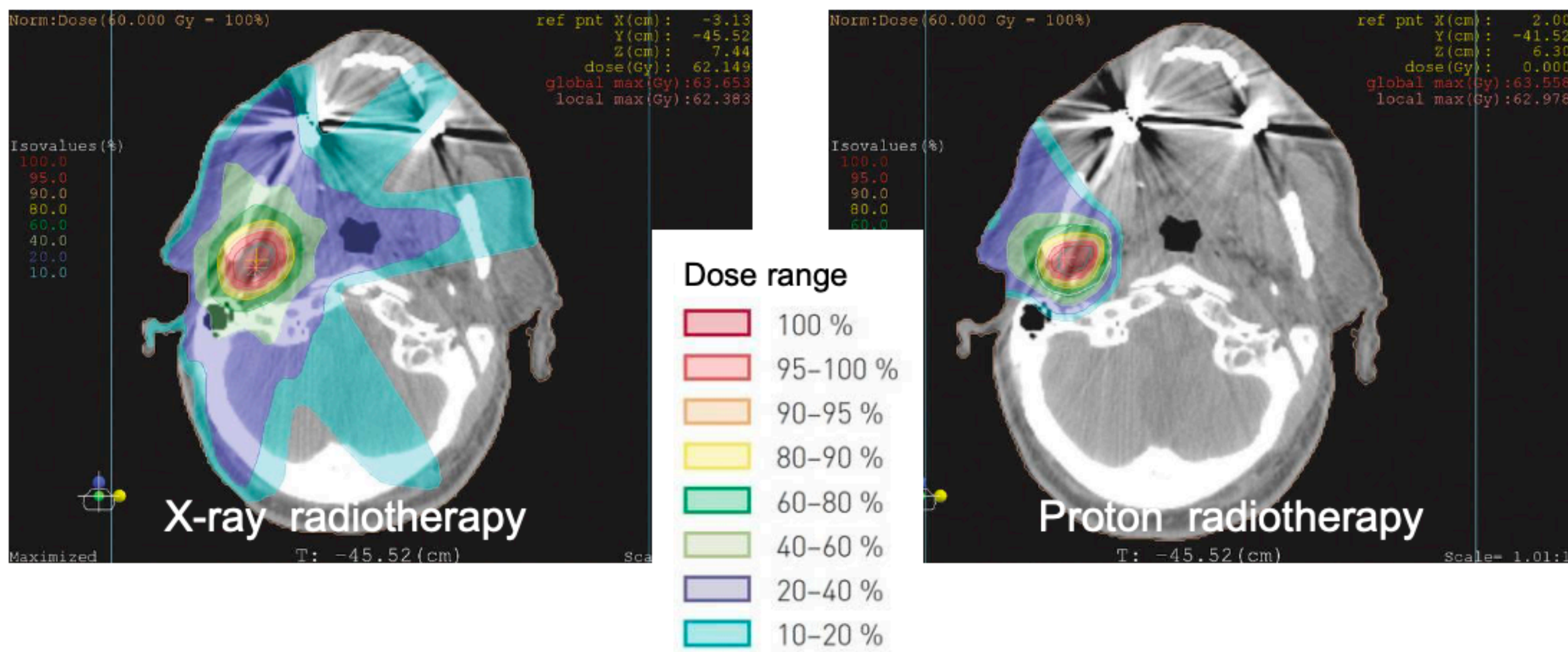

Wink et al. 2014

Treatment sites:

- **Paediatrics – reduced occurrence of secondary cancers**
- **Tumours near critical organs**

Particle therapy advantages:

- **Potential for much improved dose targeting**
- **Much reduced entrance and exit dose**

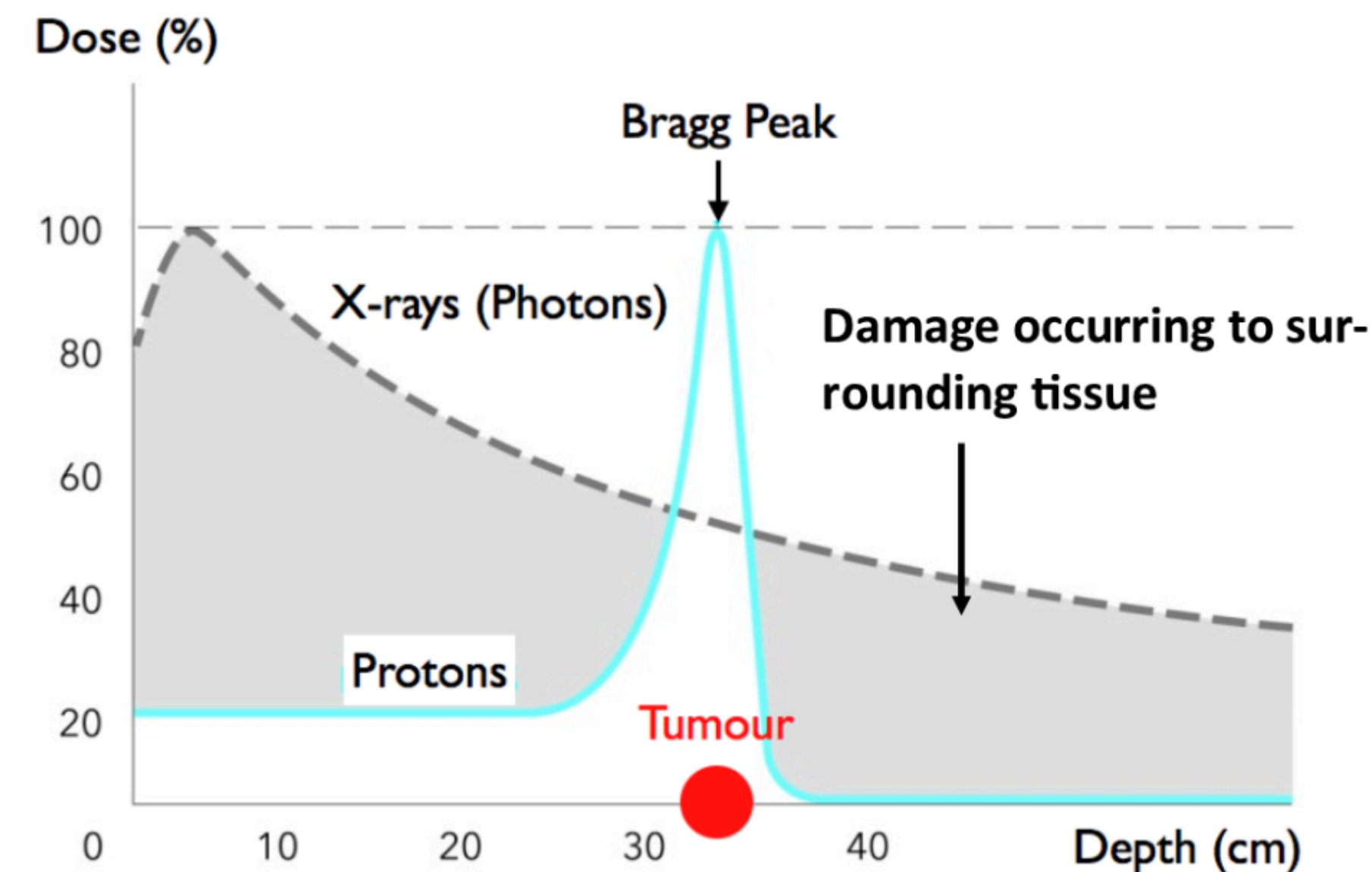

Spread out bragg peak (SOBP)

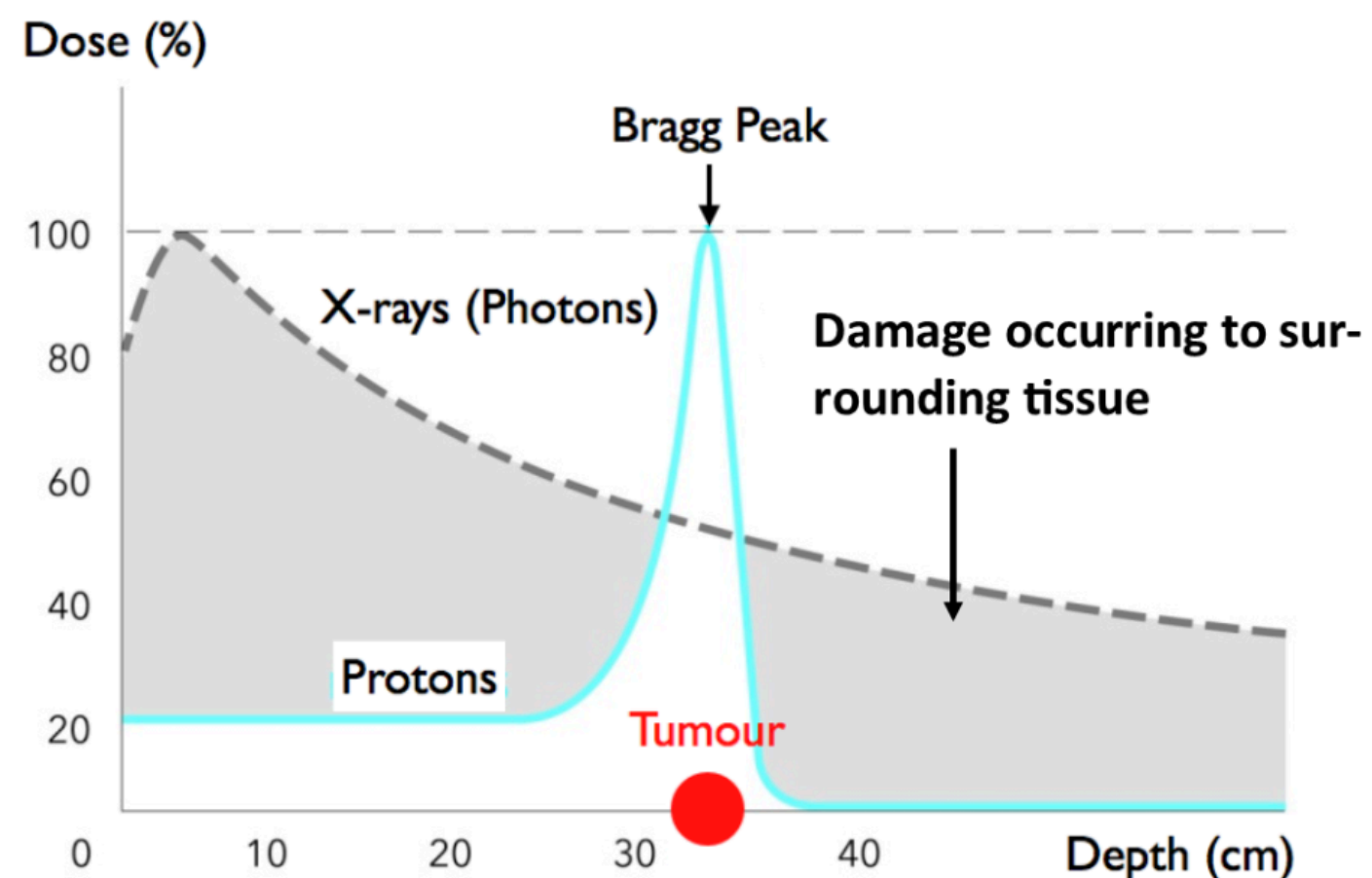

An unhelpful caricature...

<https://www.mdpi.com/2072-6694/11/7/946>

Figure 1. Depth–dose distribution of protons and relationship to energy and linear energy transfer (LET). **(A)** An unmodulated (pristine) Bragg peak produced by a proton beam. **(B)** Spread-out Bragg peak (SOBP) from several modulated proton beams.

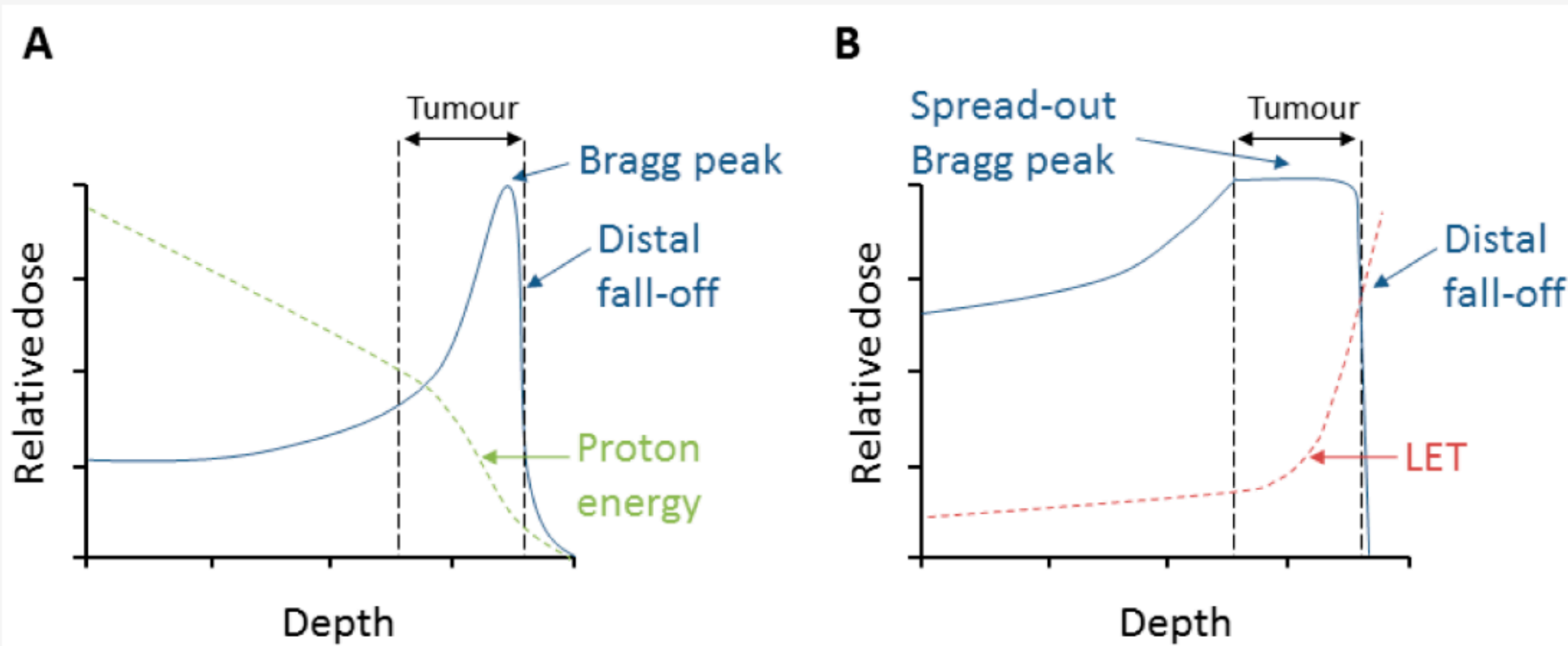

$$-\frac{dE}{dx} = \frac{4\pi}{m_e c^2} \cdot \frac{nz^2}{\beta^2} \cdot \left(\frac{e^2}{4\pi\epsilon_0}\right)^2 \cdot \left[\ln \left(\frac{2m_e c^2 \beta^2}{I \cdot (1 - \beta^2)} \right) - \beta^2 \right]$$



Passive scattering

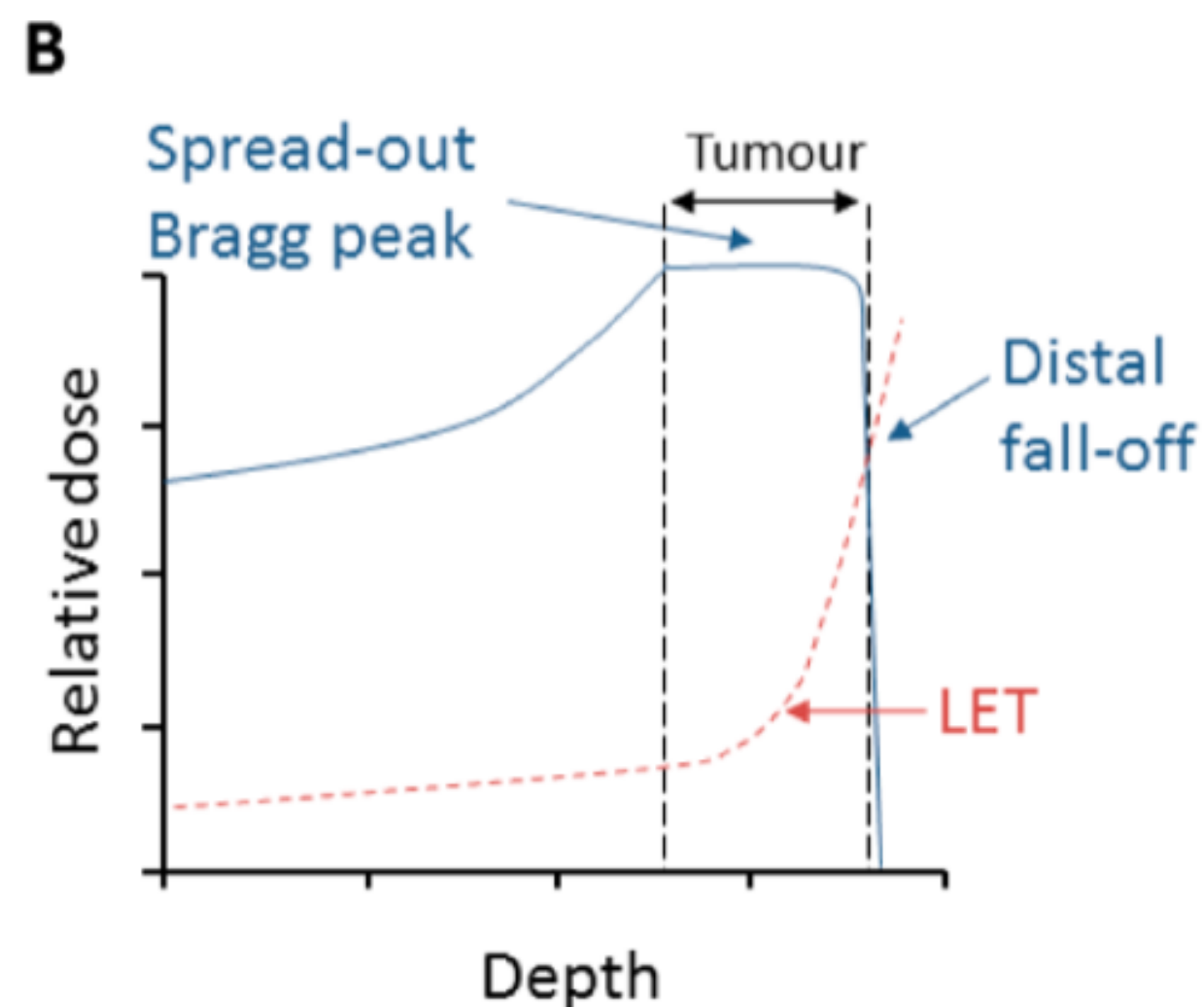

Clatterbridge – 62 MeV Scanditronix cyclotron
Basis for much UK technology and clinical-related research

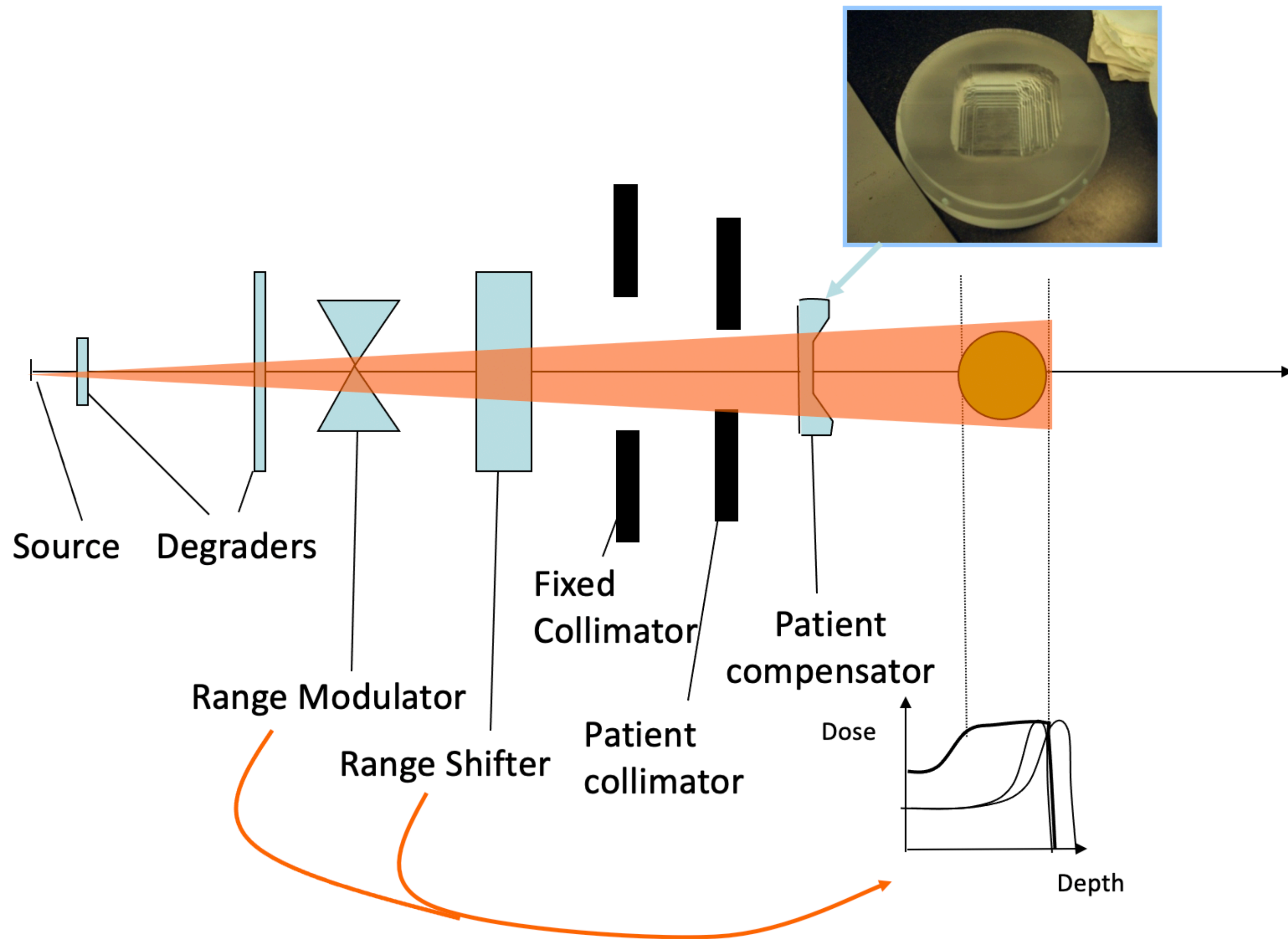



Spot scanning

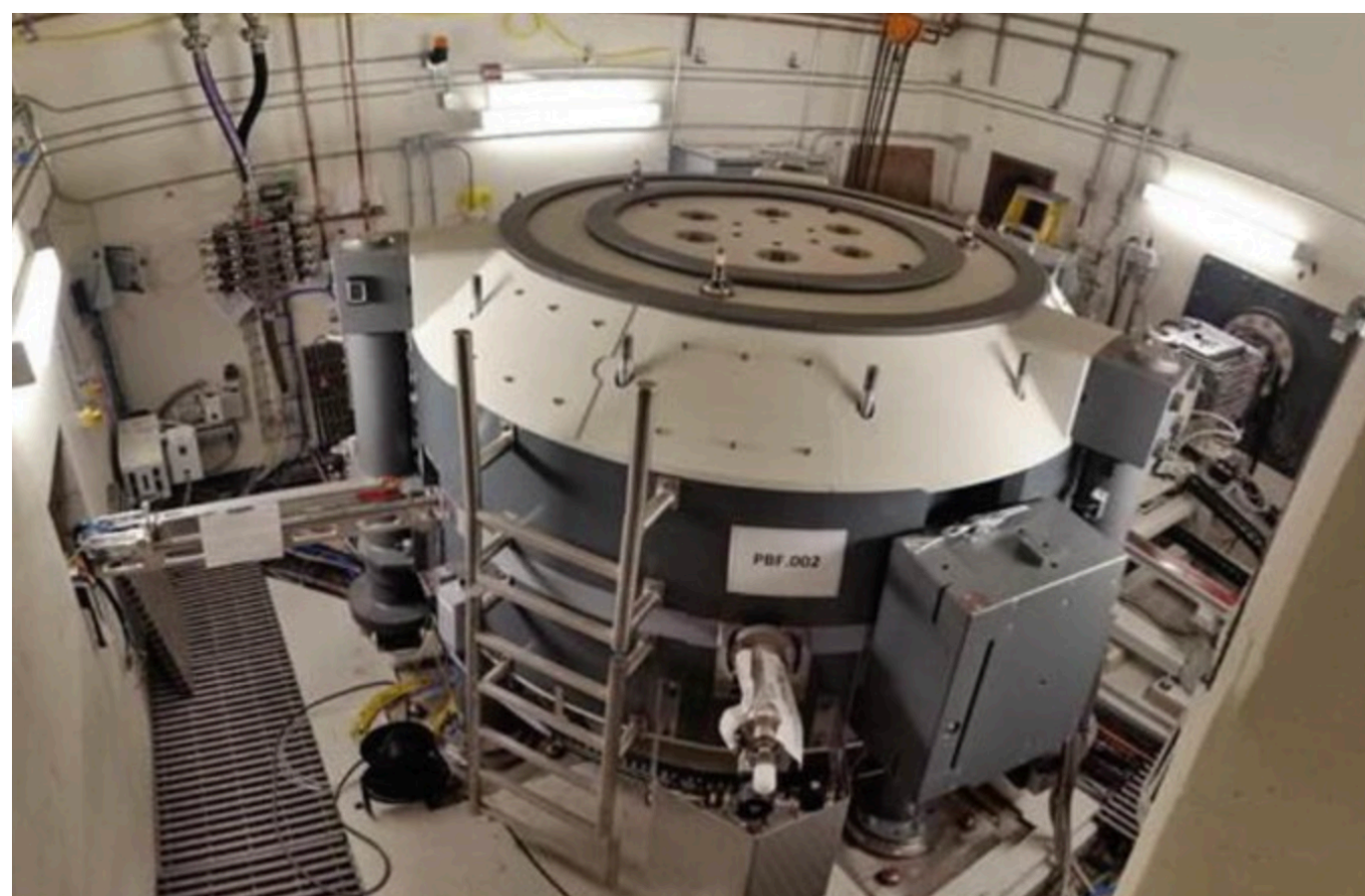
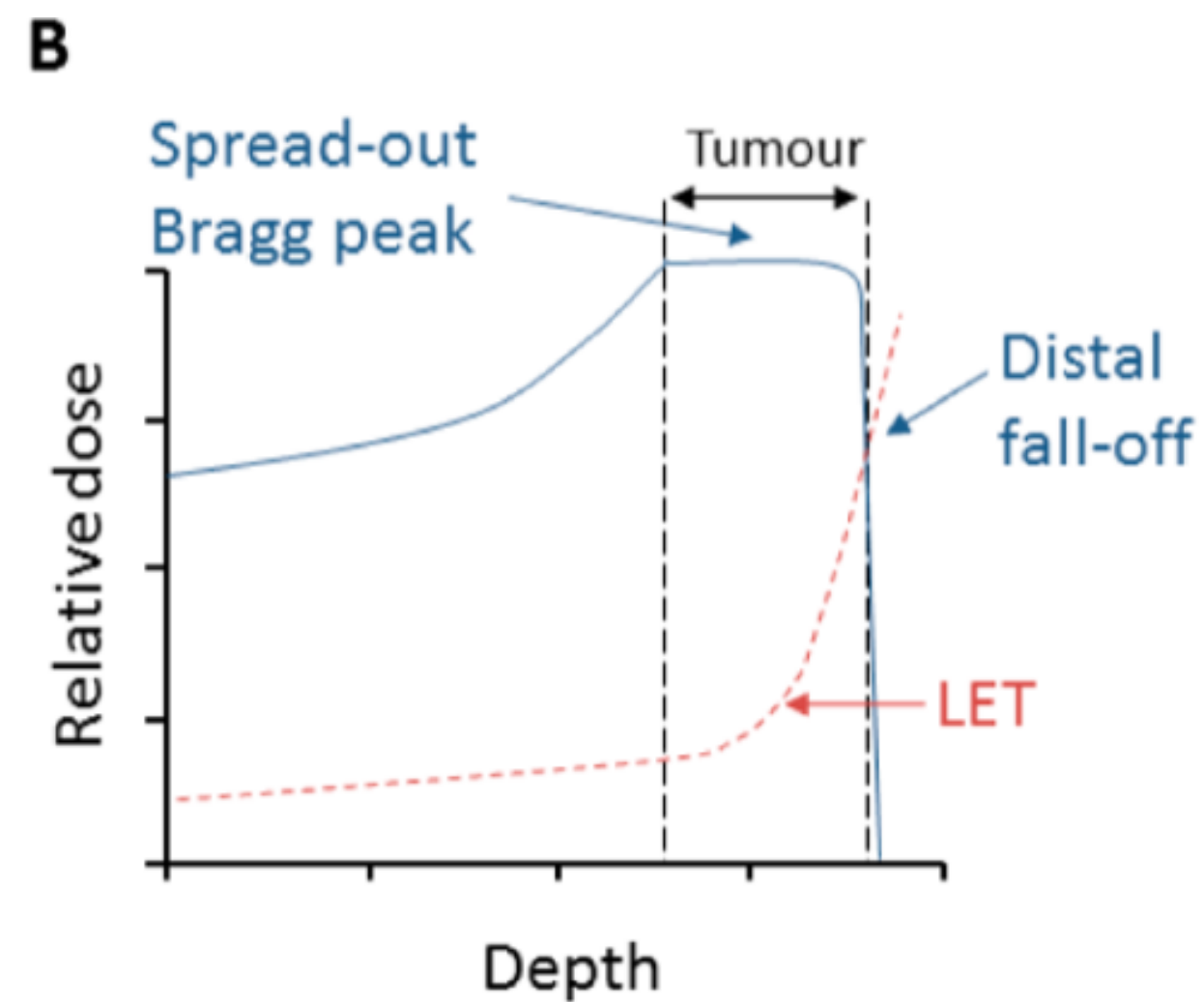

IBA Proteus one superconducting cyclotron (230 MeV protons)

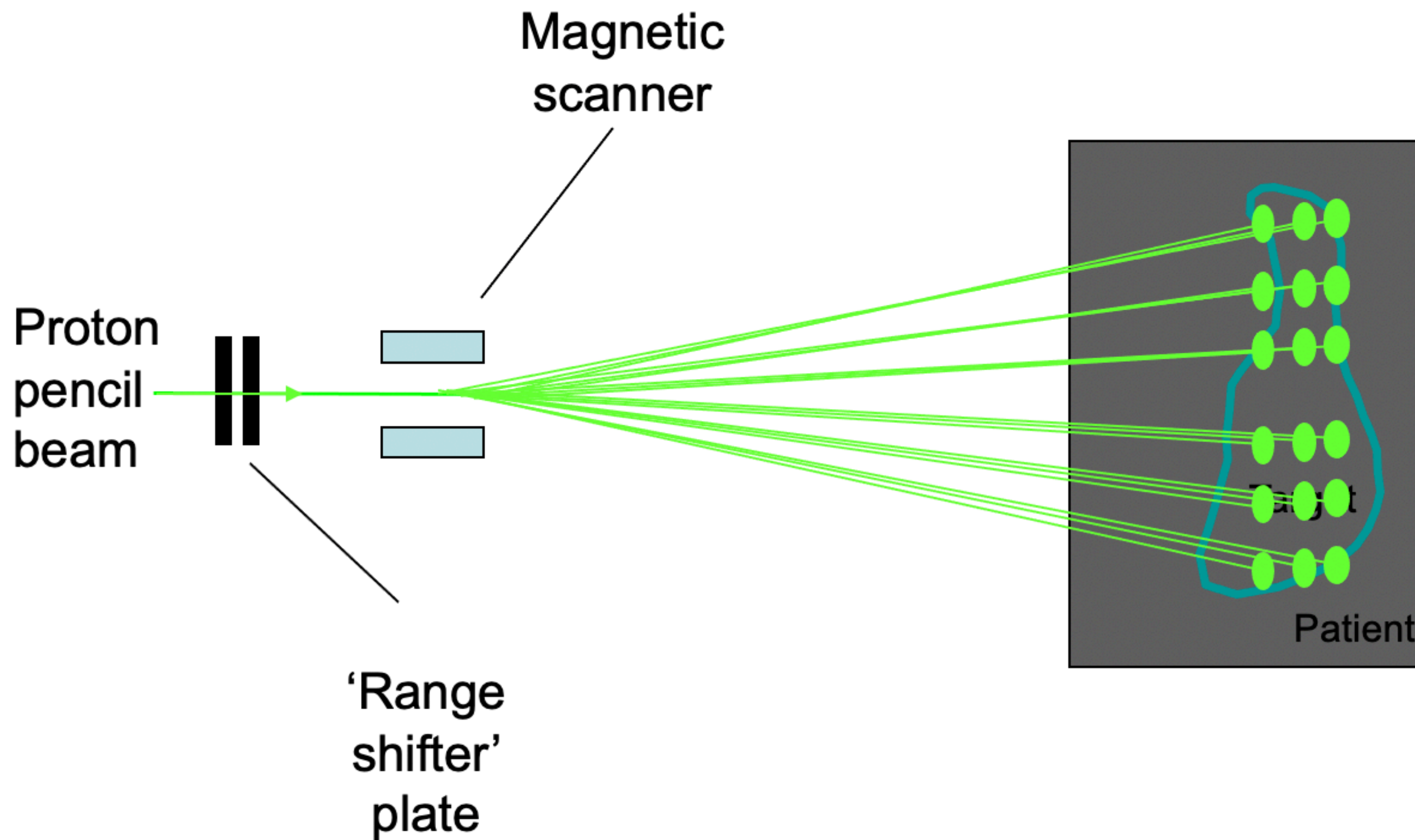



Passive scattering vs pencil beam scanning

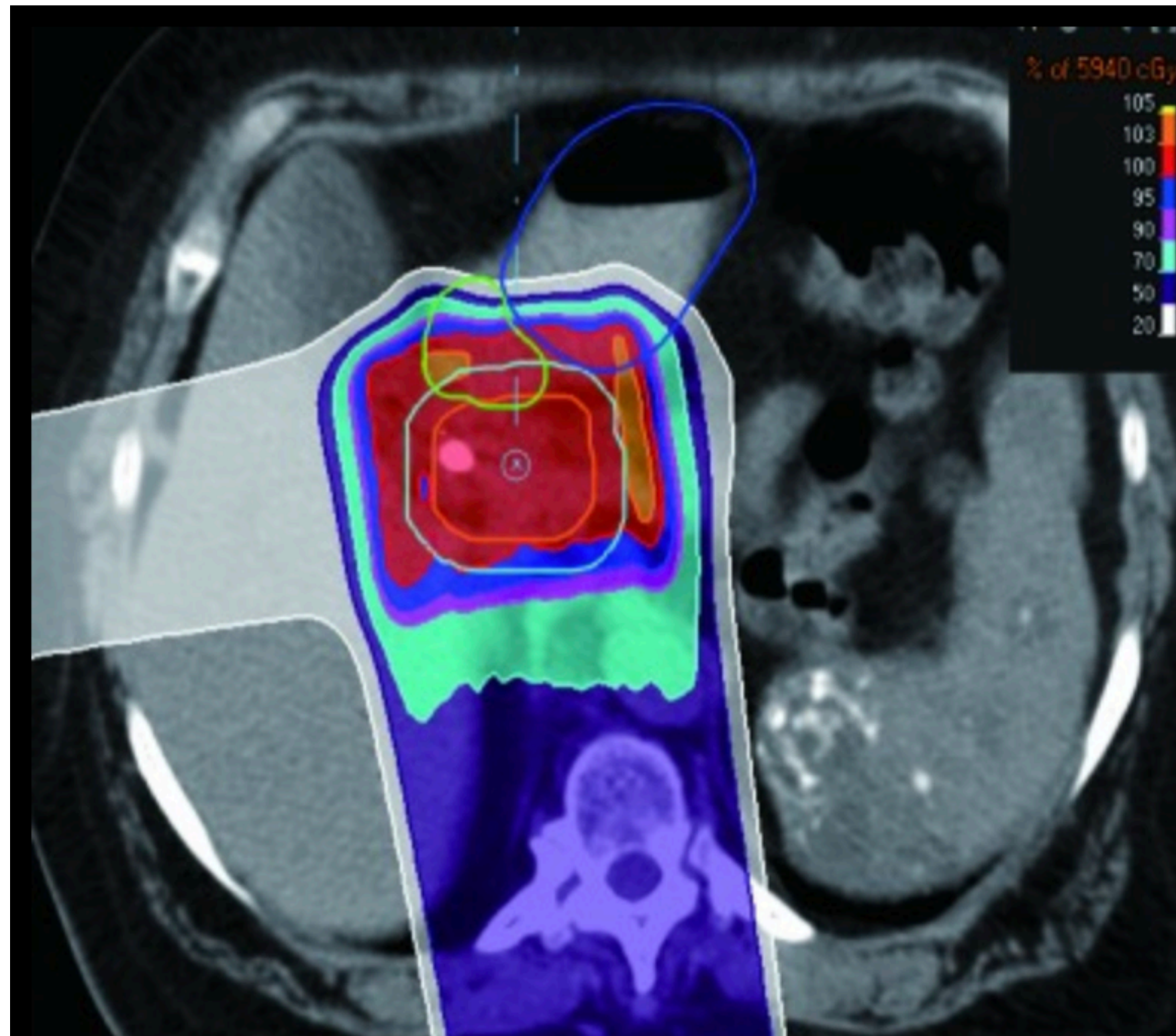
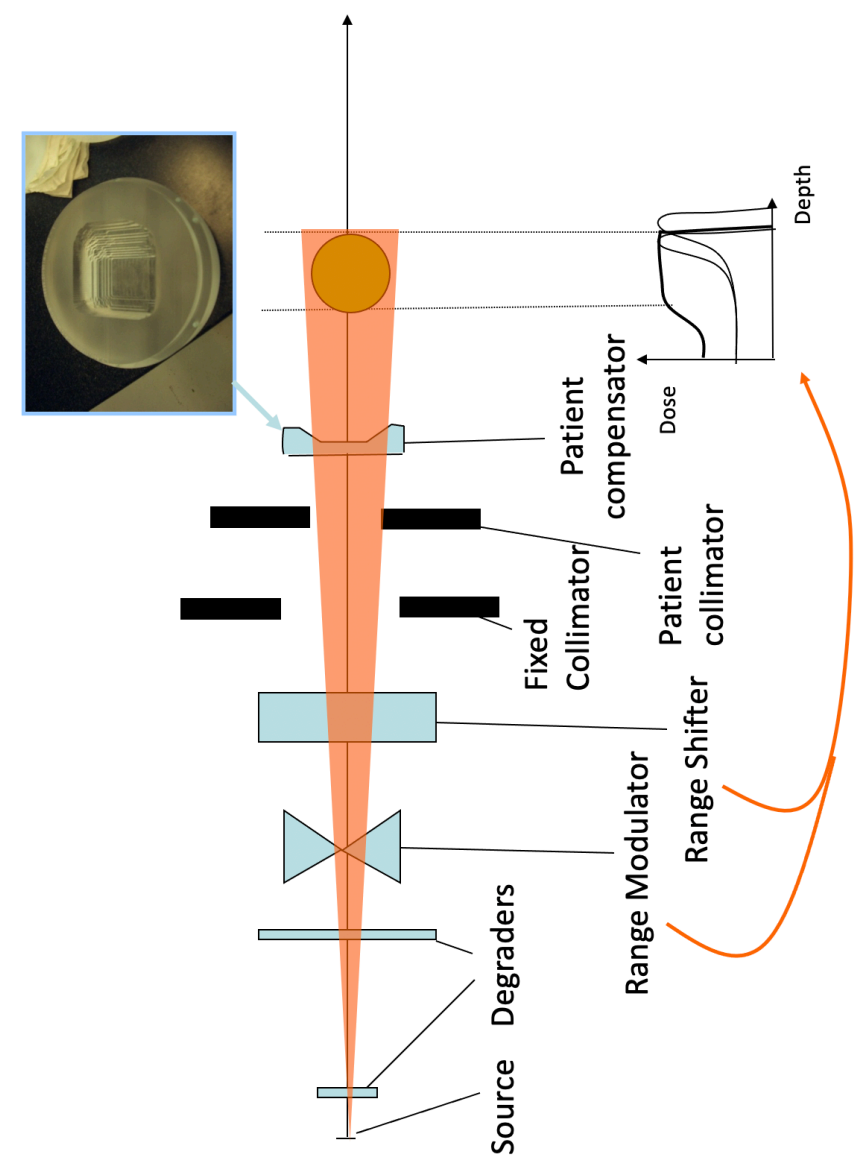

Passive scattering

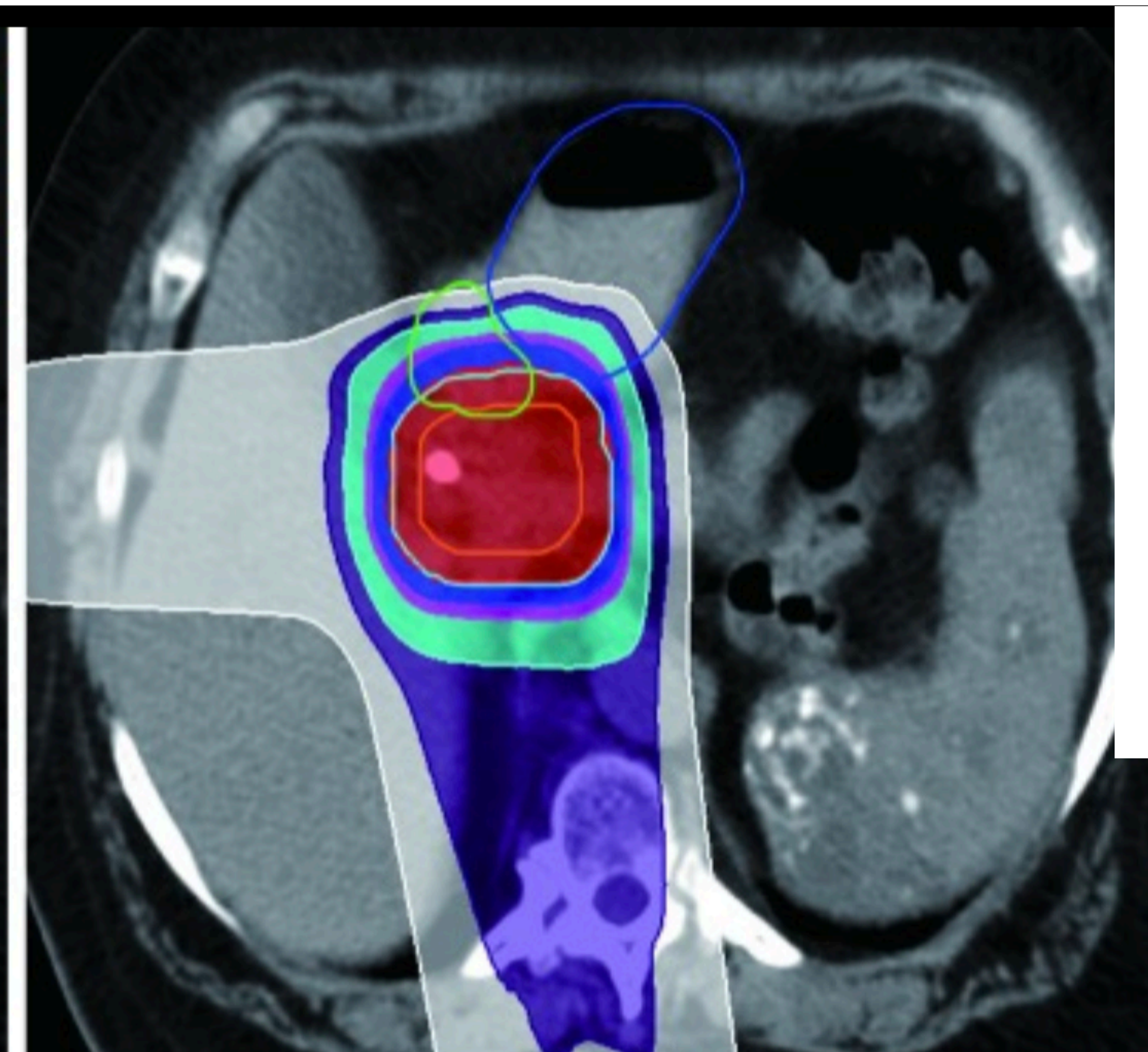

Pencil beam scanning

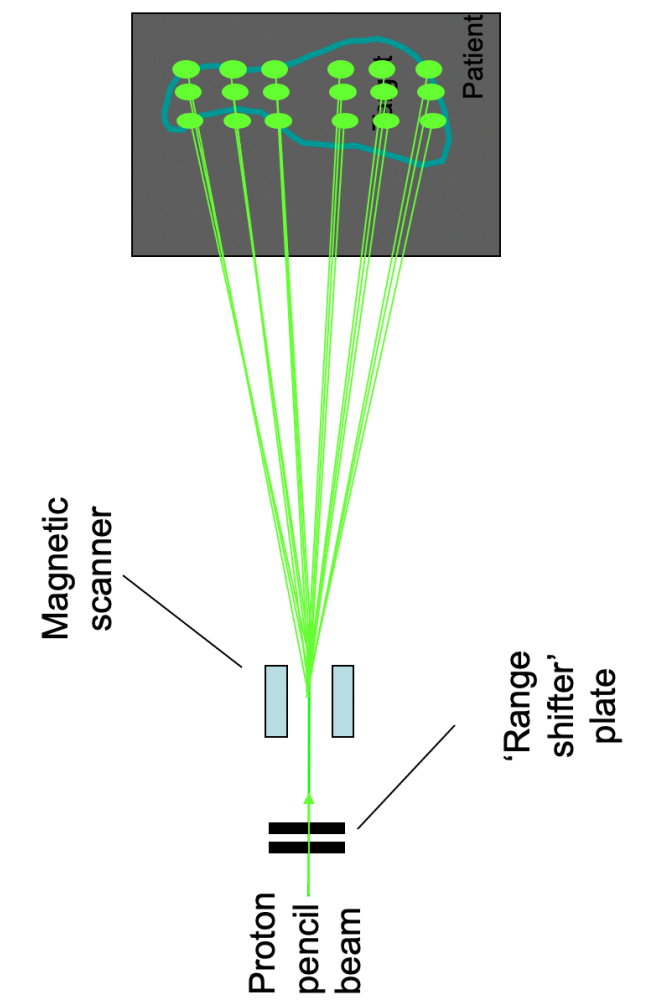



Gantry vs fixed target

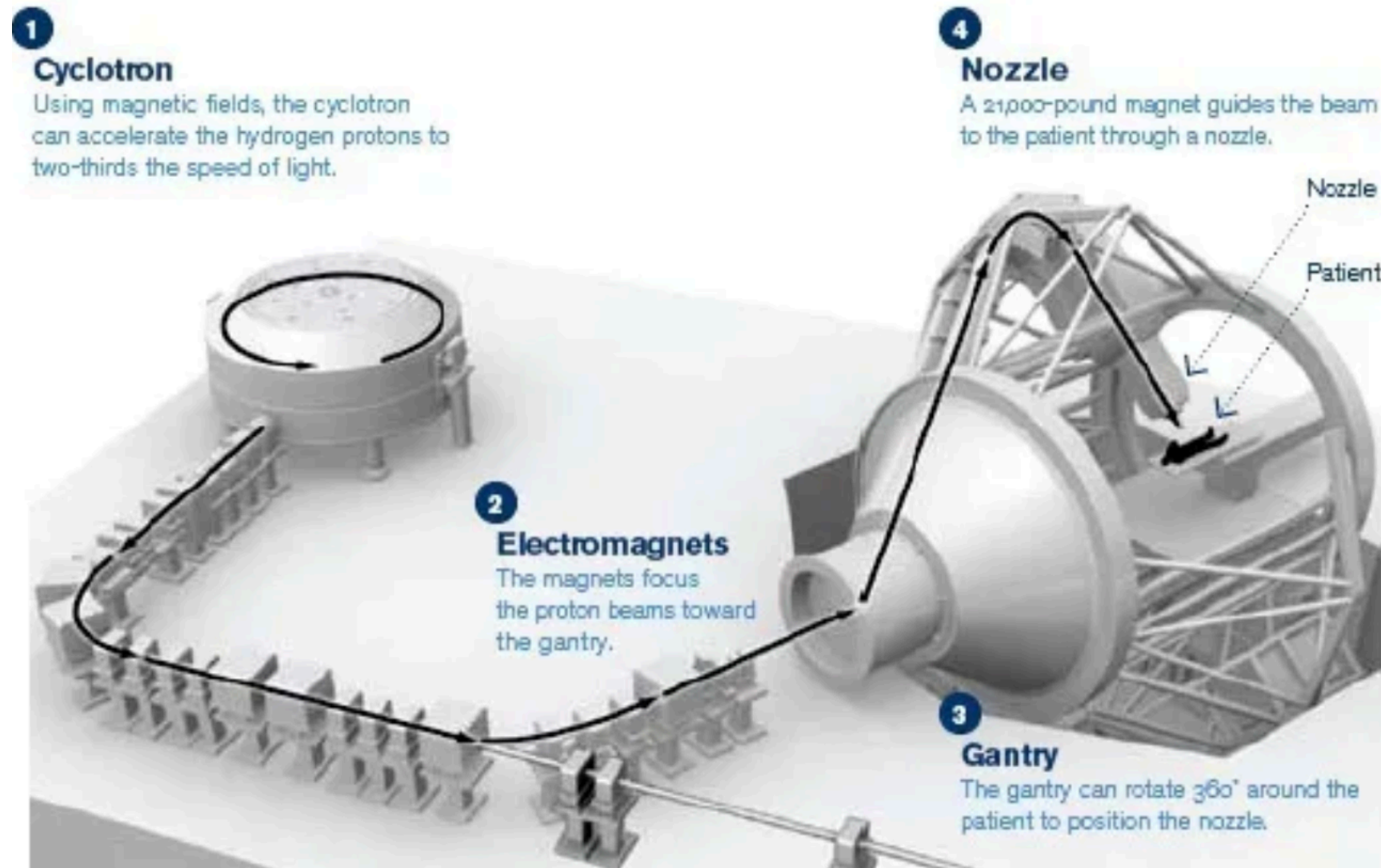

Fixed target proton therapy (Clatterbridge, UK)

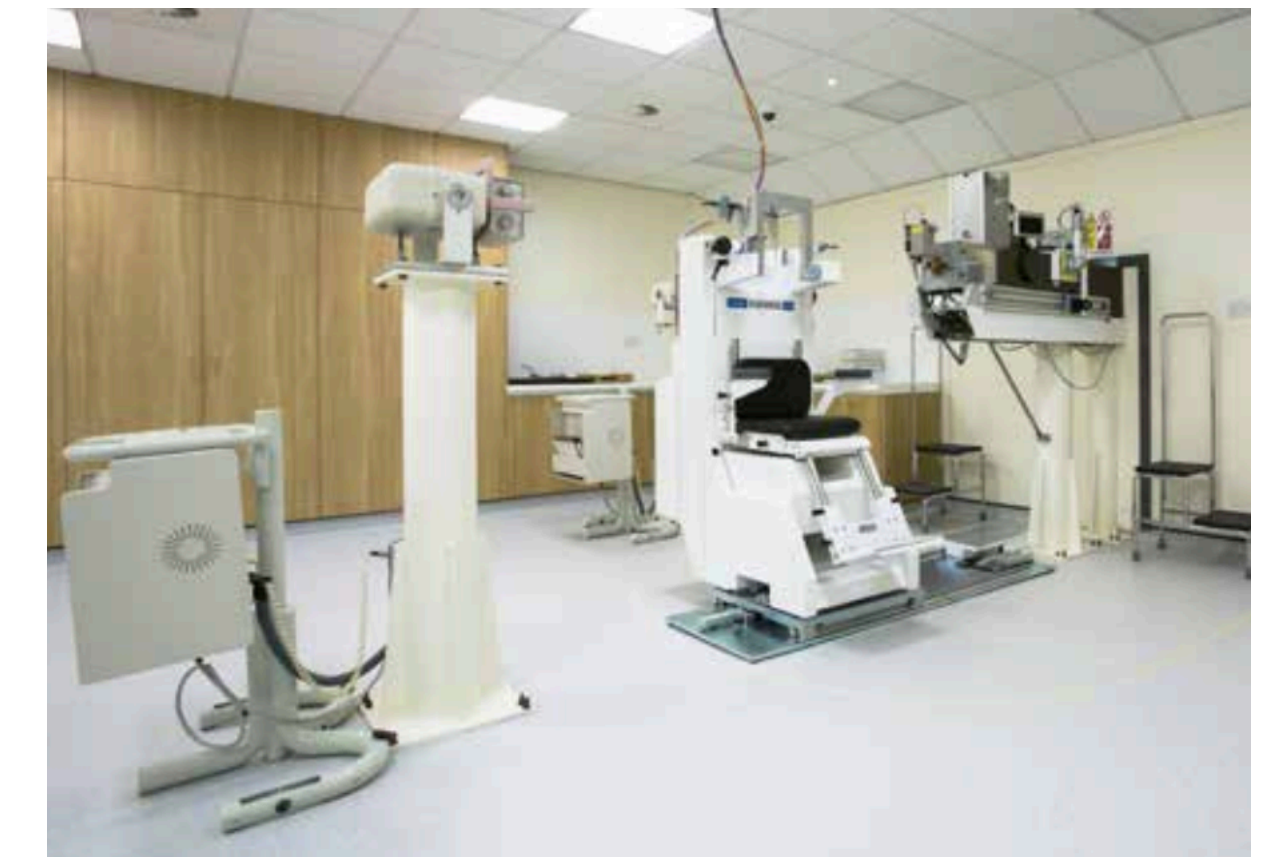

- For x-ray machine whole linac is inside the gantry
- For protons or ions the whole beam line including magnets has to rotate around the patient
- Huge additional cost for particle therapy centres

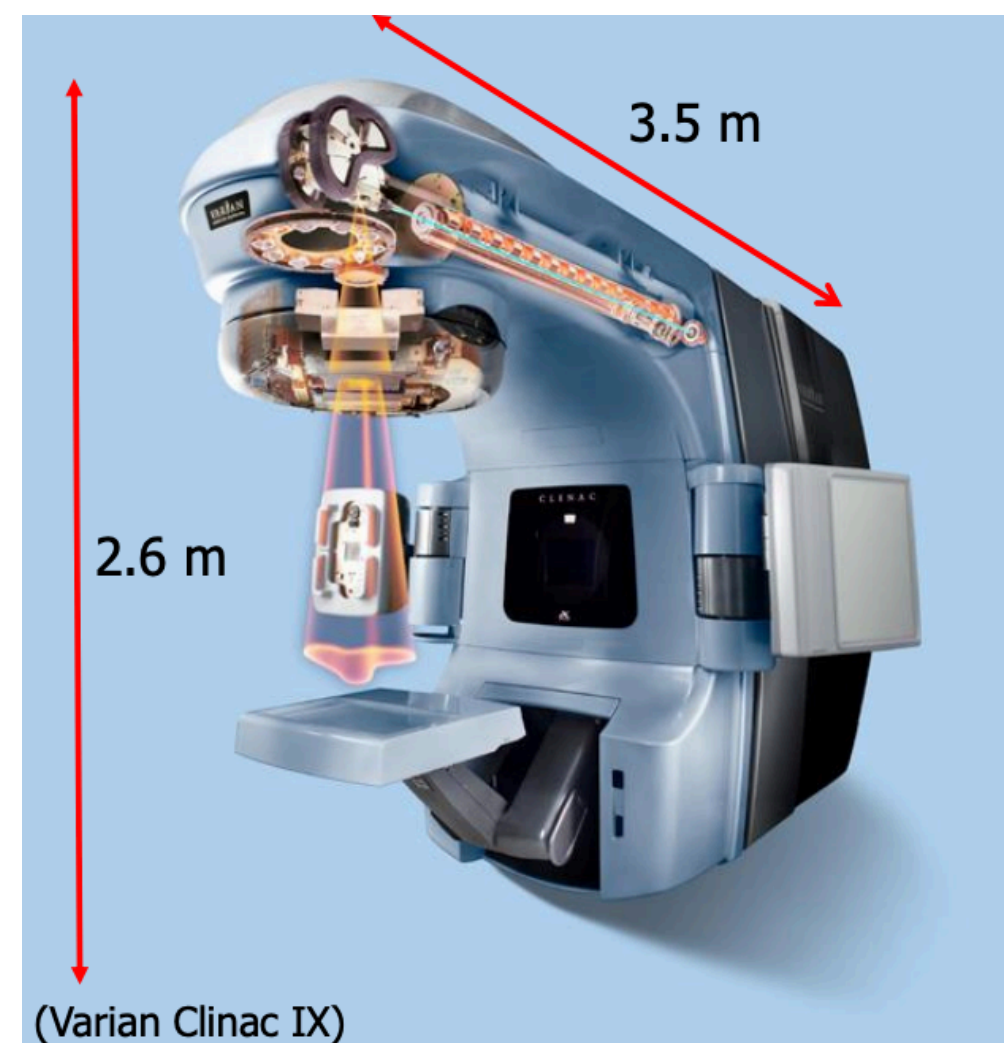

Gantry vs fixed target

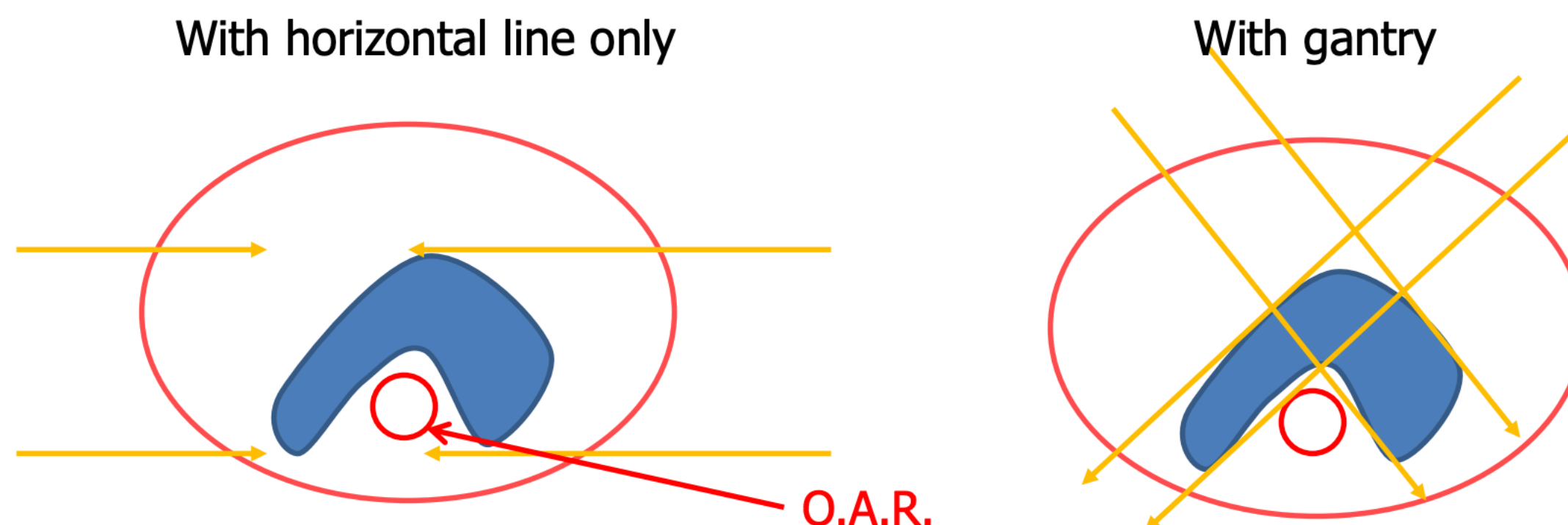

- To treat patients in the same position in which CT, PET and MRI were acquired.
- Patient rotation only around gravity to preserve internal organs and soft tissue geometry
- To provide the maximum flexibility in selecting the irradiation direction when optimising the dose delivery
- To allow a “robust” treatment planning. Exploiting the sharp distal fall off can be risky in some cases and a gantry helps in avoiding fields directed towards an Organ At Risk (OAR)
- Avoid density heterogeneities
- Minimize SOBP extension (less energies required and better peak to plateau ratio)
- For x-ray machine whole linac is inside the gantry
- For protons or ions the beam line including magnets (!) has to rotate around the patient



Carbon gantry vs proton gantry!

Carbon Gantry

- The HIT Gantry: the only clinical C Gantry
- $L = 25\text{ m} \times f = 13\text{ m}$, 600 t rotating mass





Beam monitoring and dosimetry

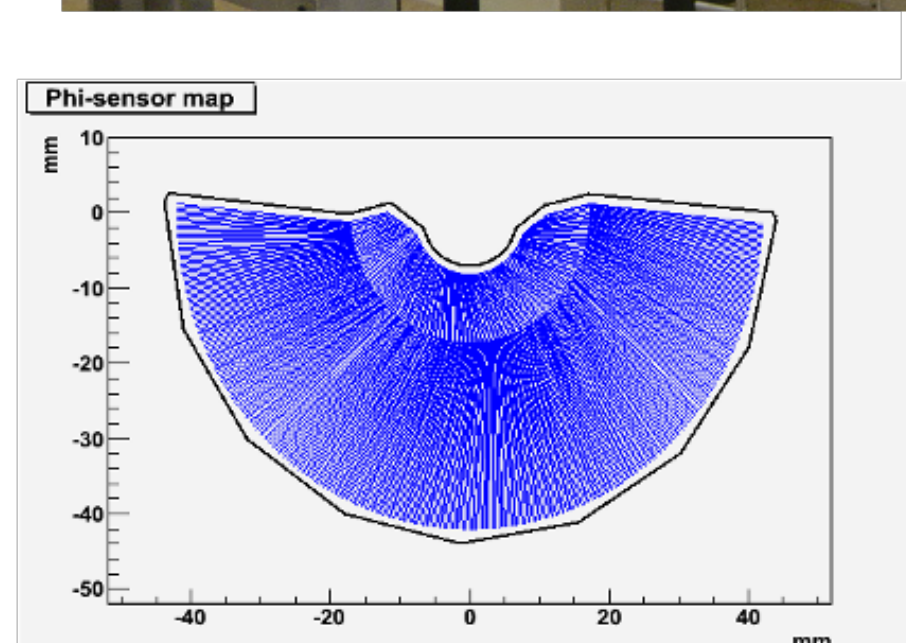
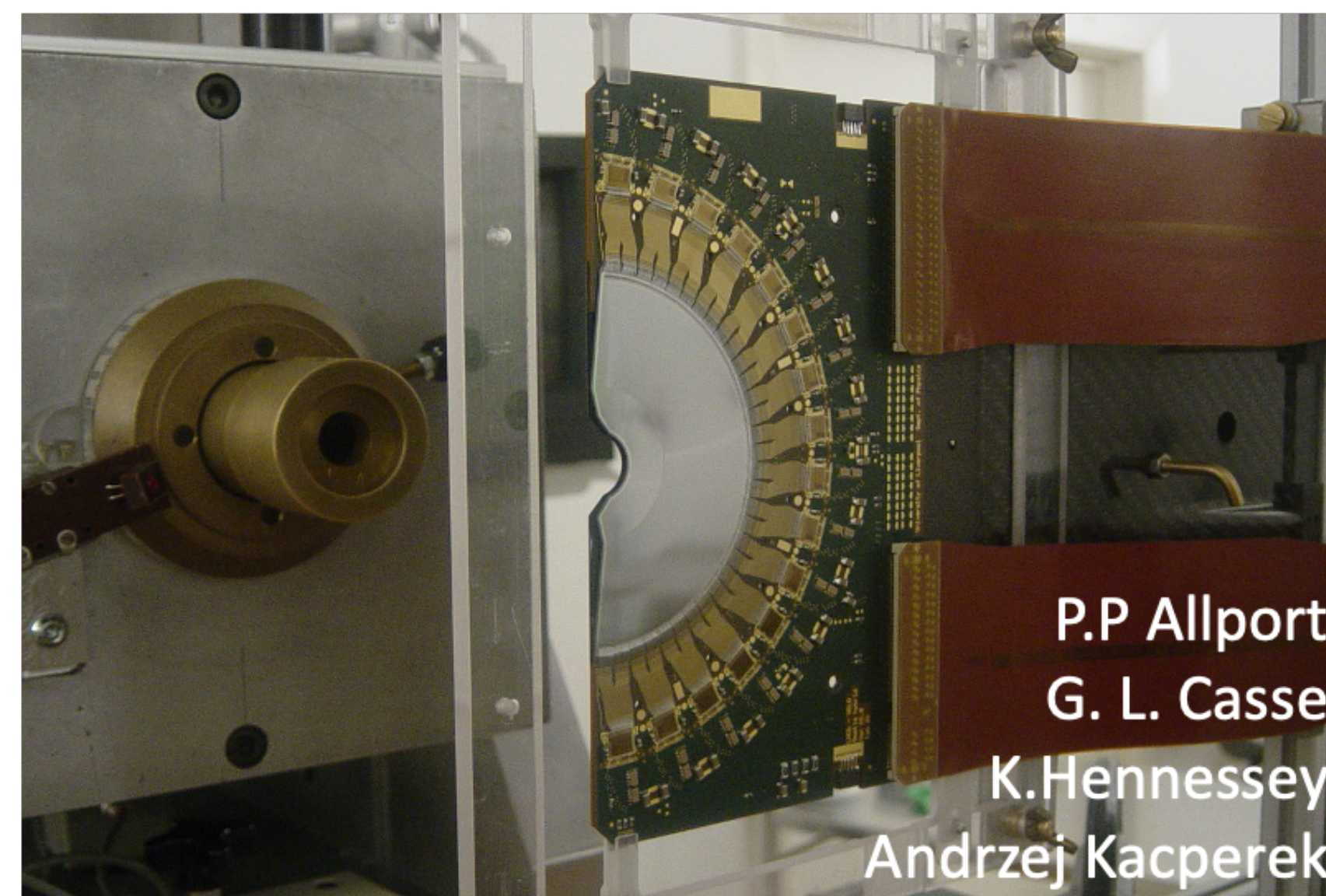

LHCb Back-to-Back Sensor Module

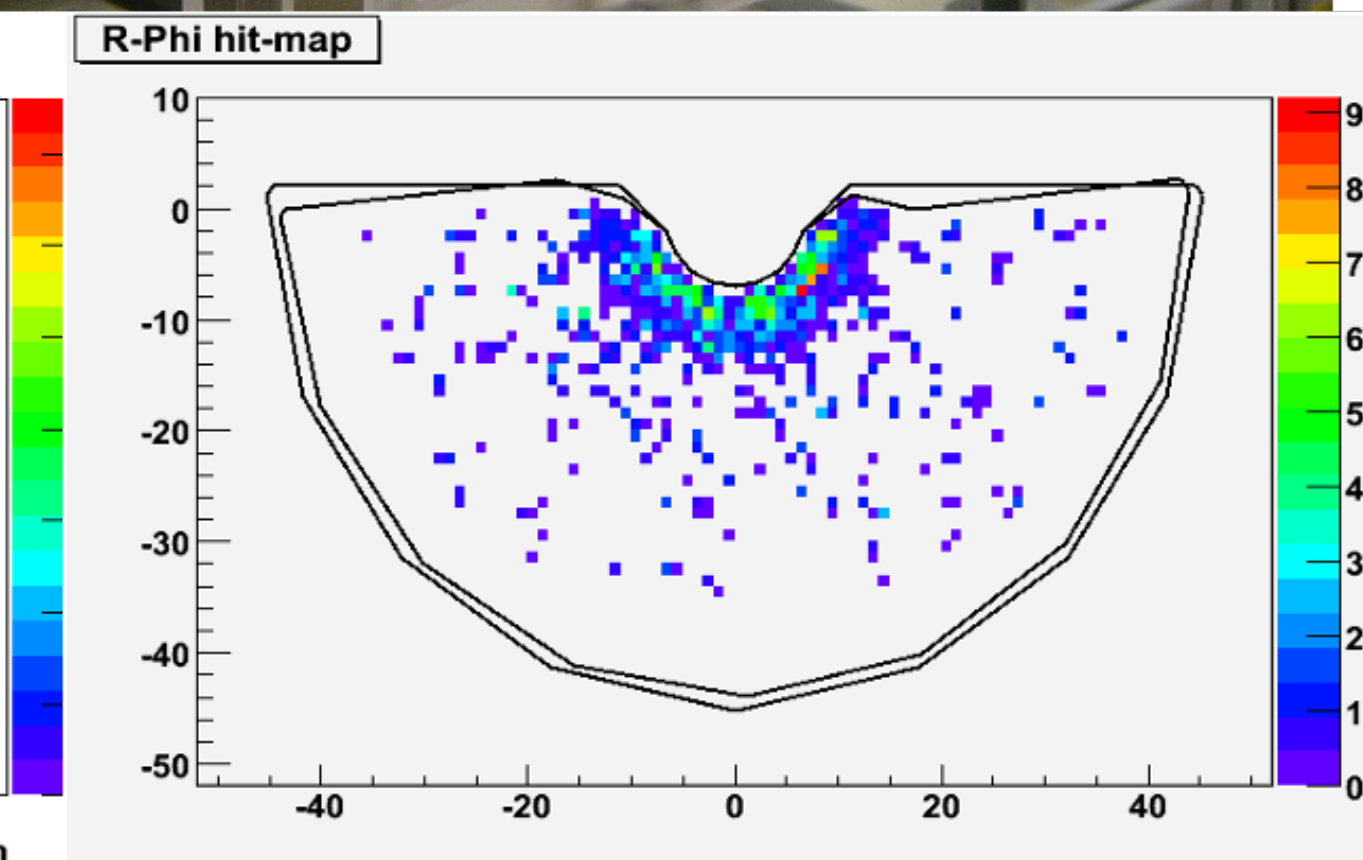
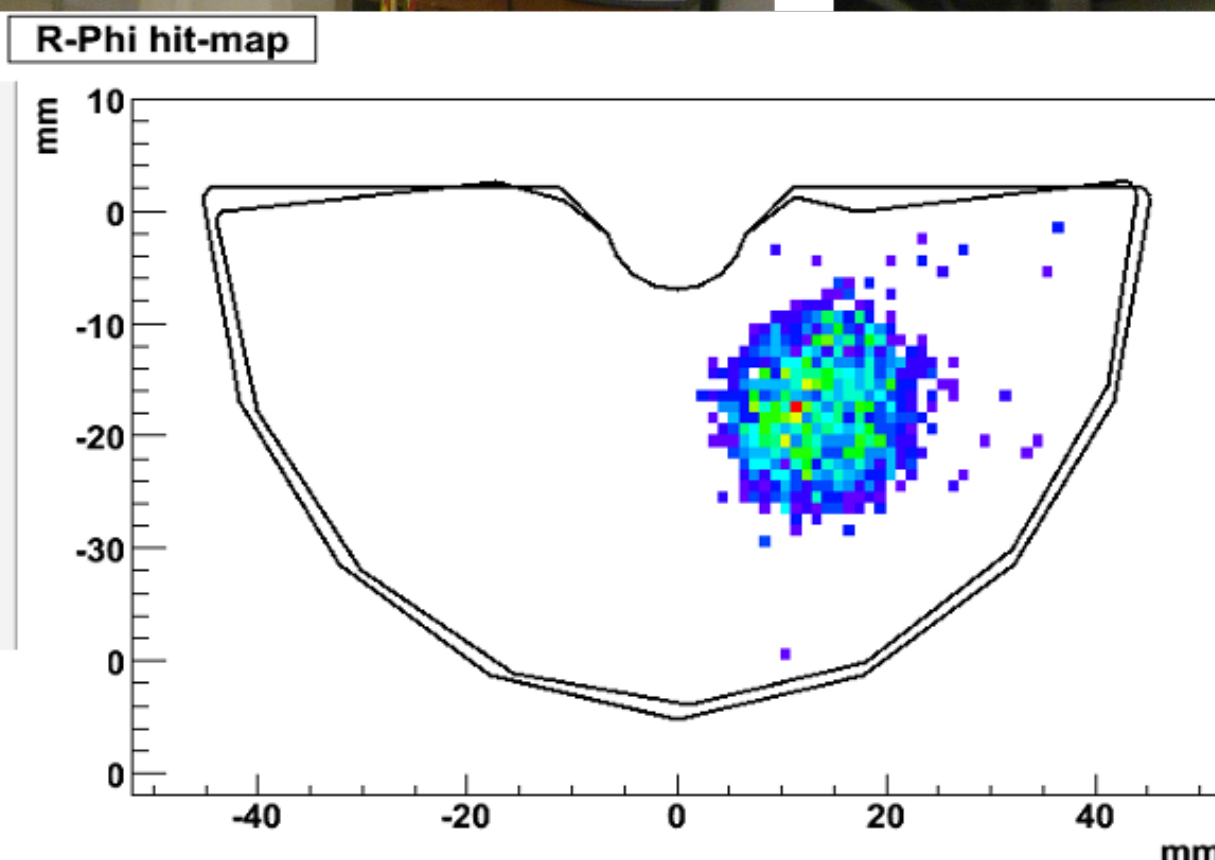



Beam monitoring and dosimetry

ProteusOne beam profile and Energy measurements with Timepix3 chip

- 25mm water depth
- 120 MeV Protons
- 107mm water depth

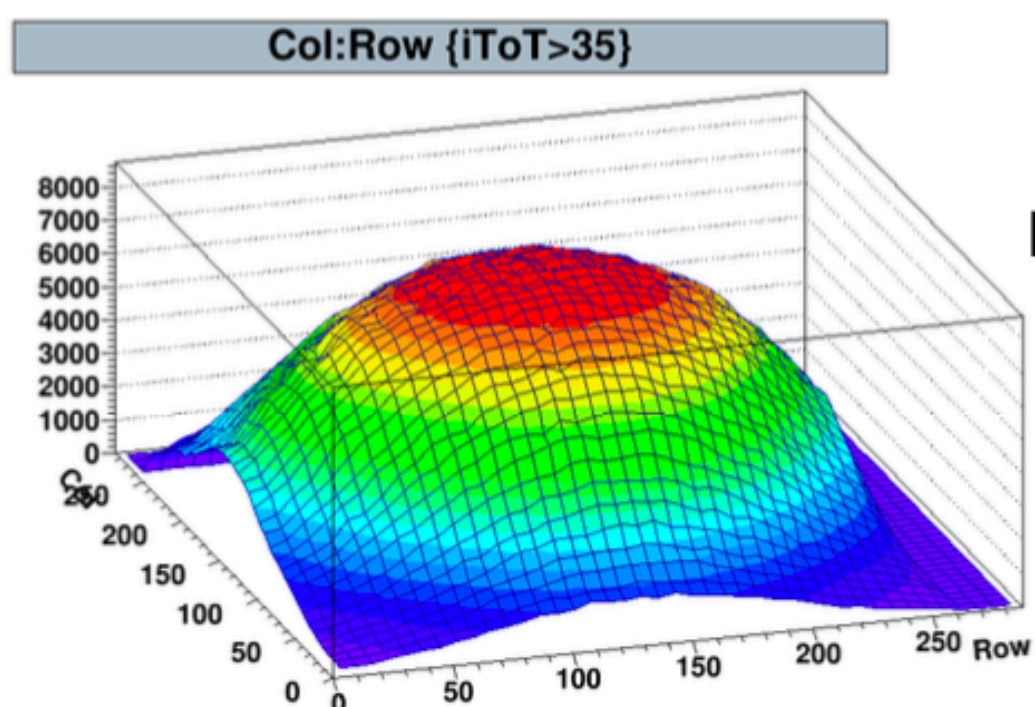

- Most energetic protons in the beam

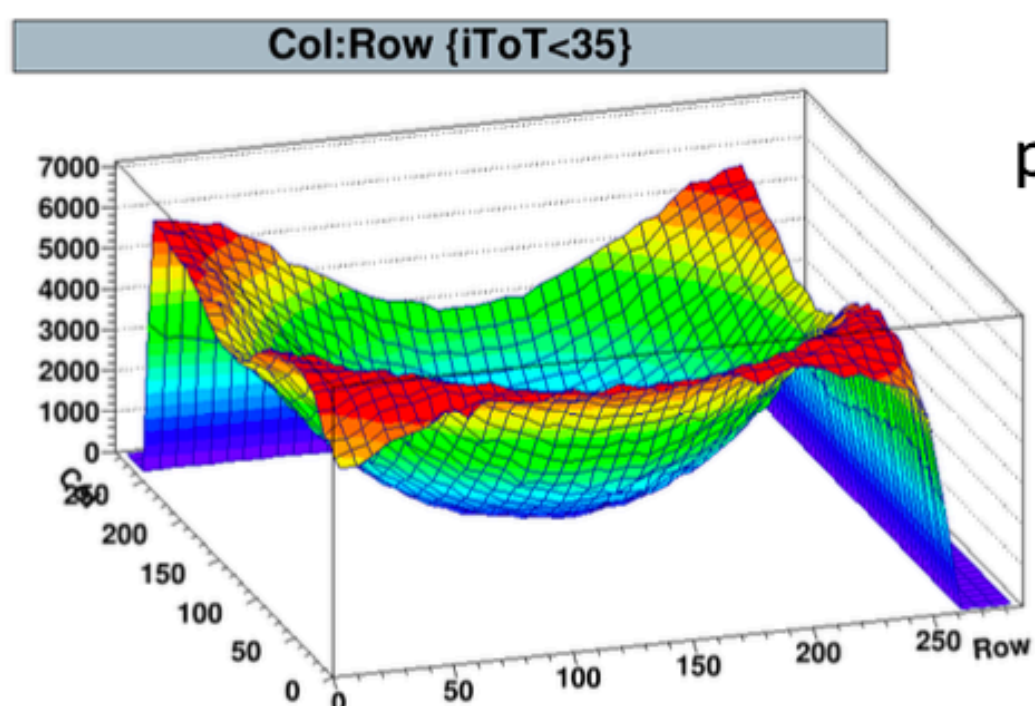
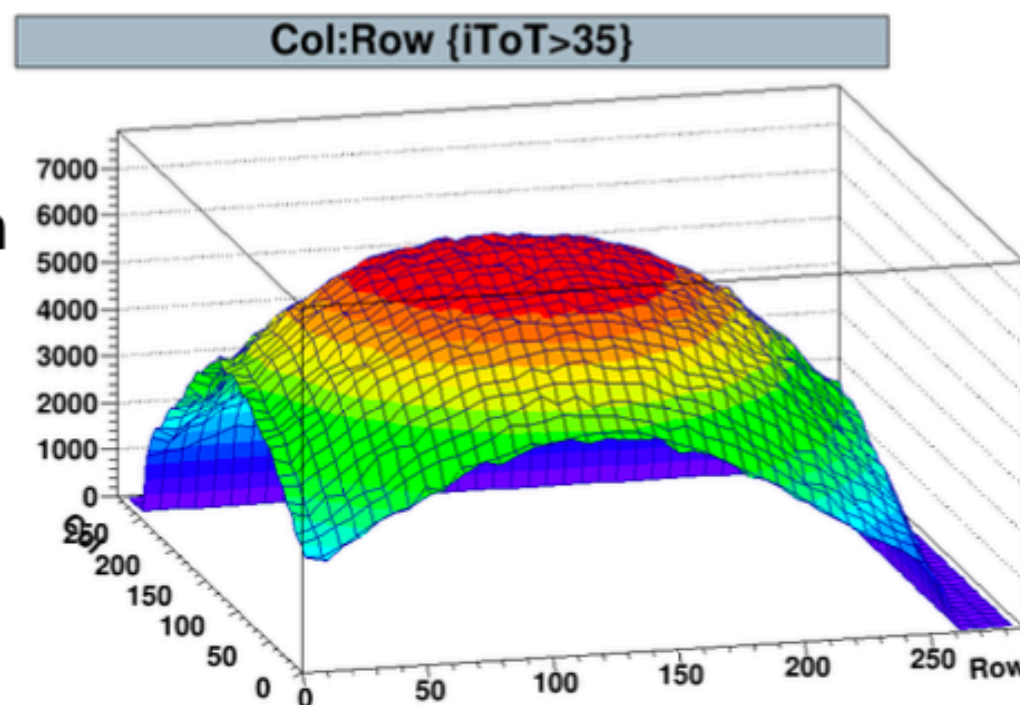

- Least energetic protons in the beam

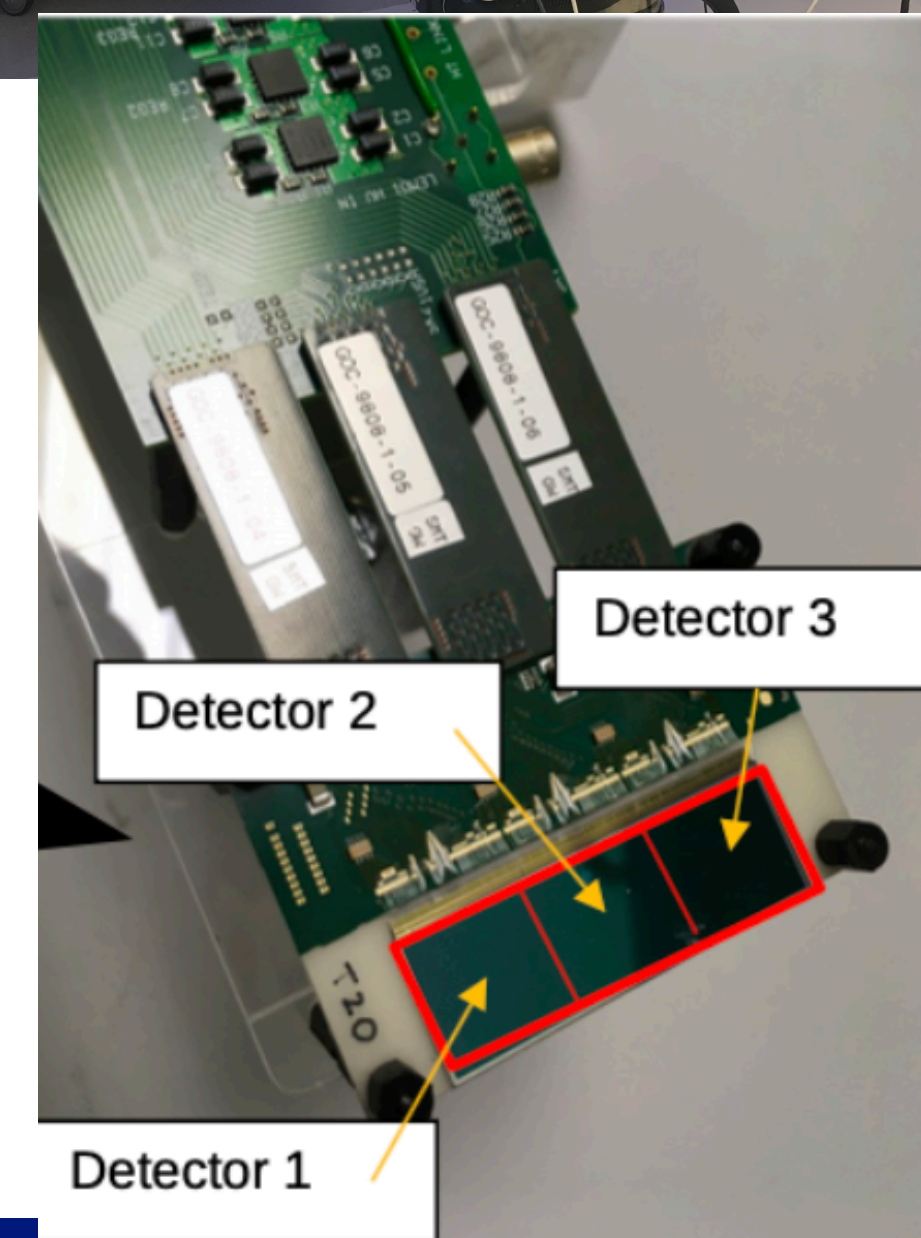
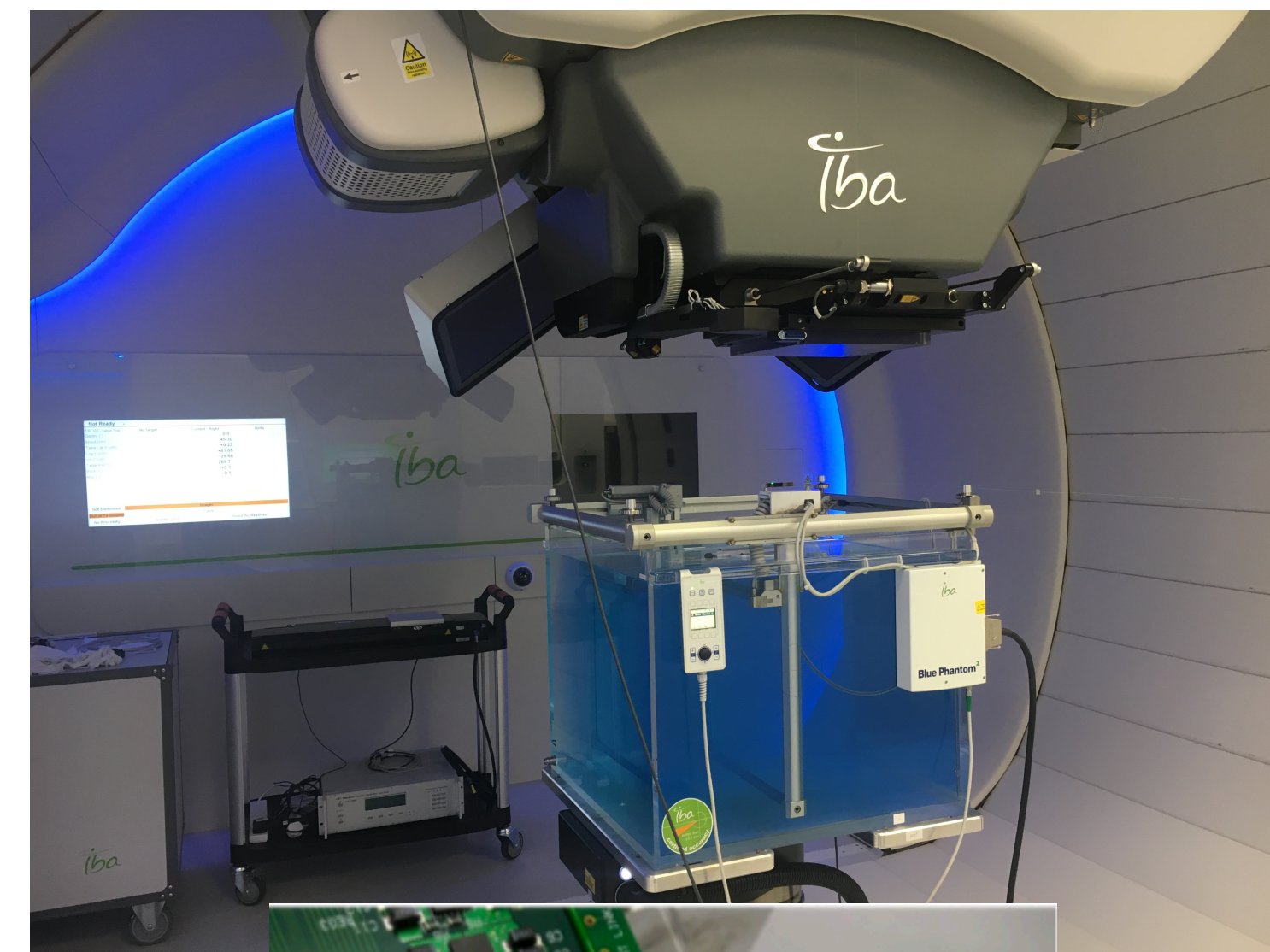
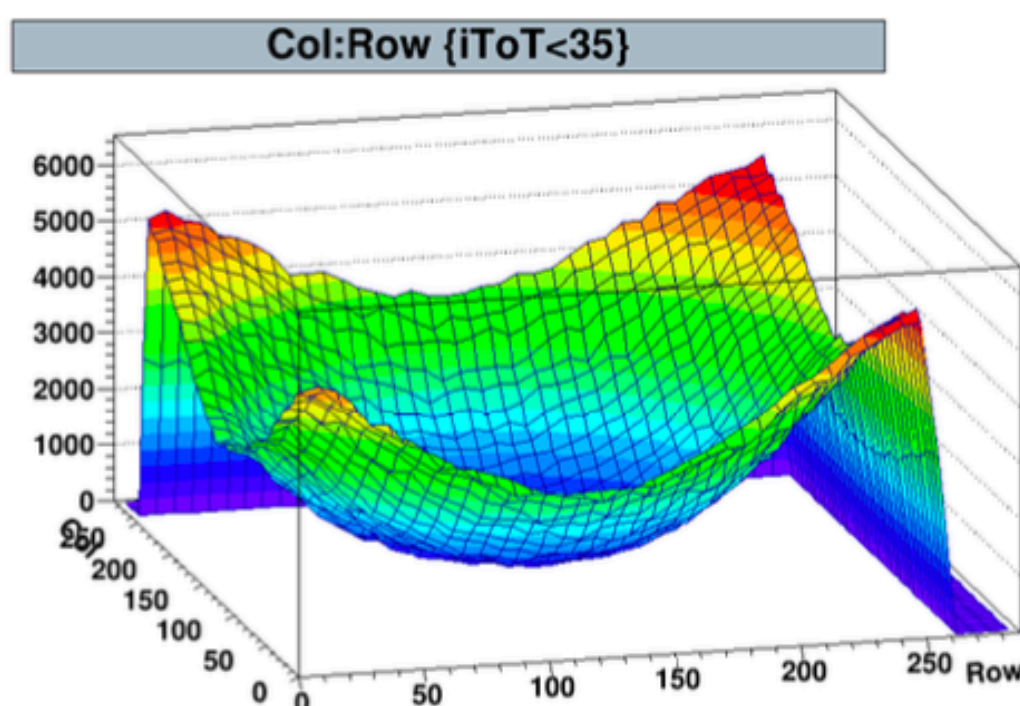

Imaging and planning

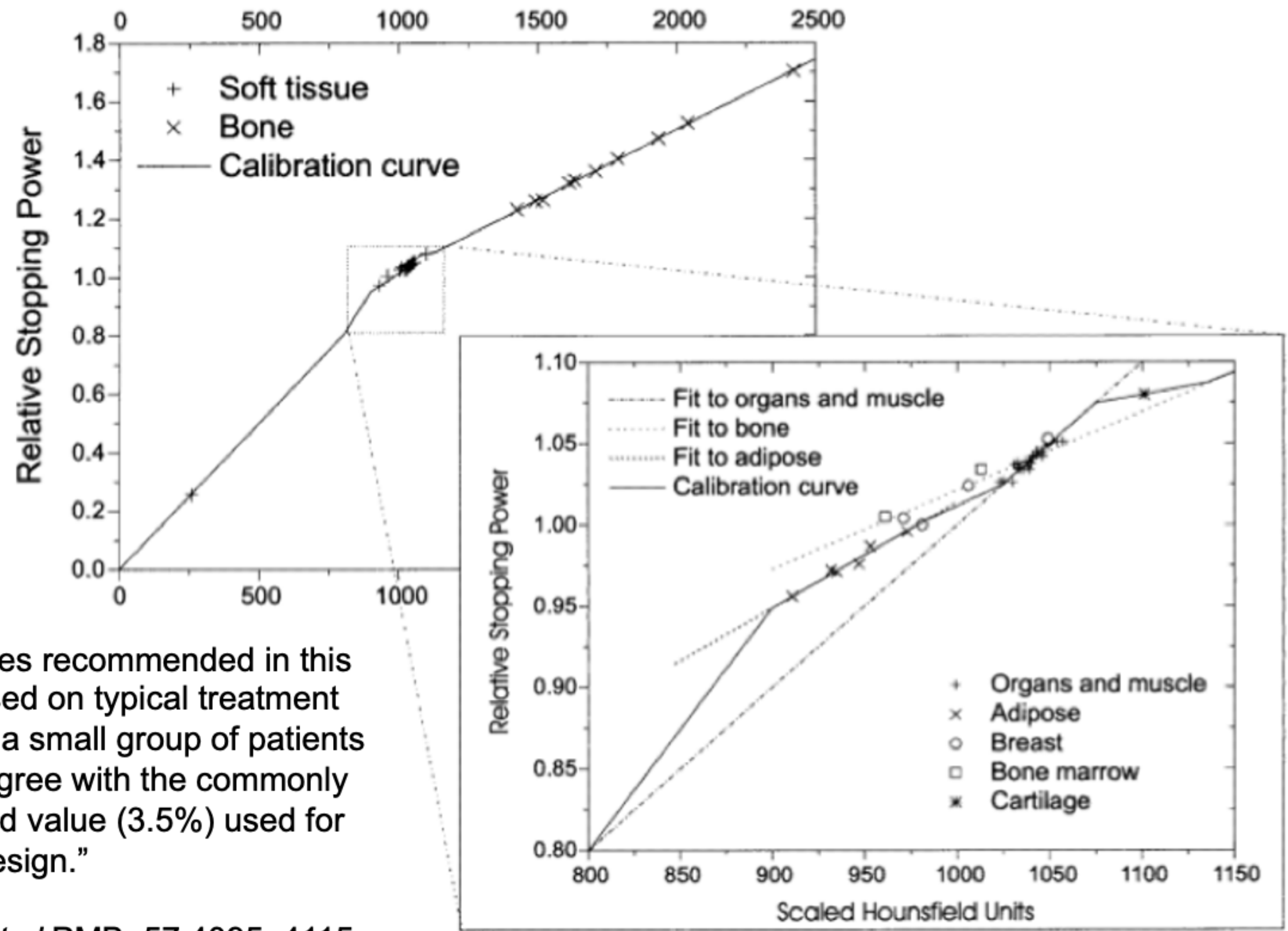

“The values recommended in this study based on typical treatment sites and a small group of patients roughly agree with the commonly referenced value (3.5%) used for margin design.”

M Yang *et al* PMB. 57 4095–4115 (2012)

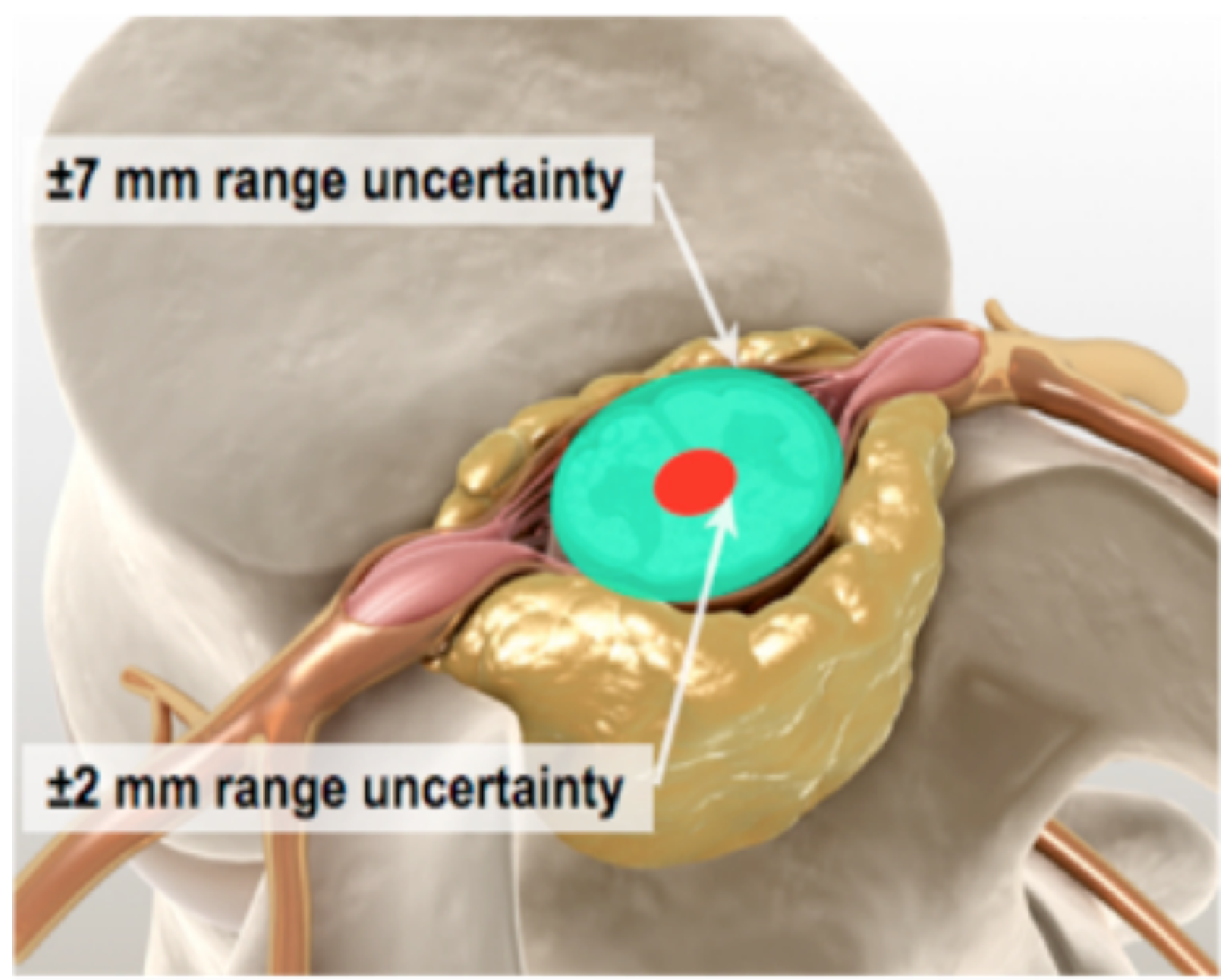

Imaging and treating with ions rather than imaging with x-rays and treating with ions offers benefits to patients



Imaging and planning: CT / radiography with ions

- Proton CT offers the potential of removing inaccuracies generated by proton treatment plans based upon X-ray CT data
- Silicon based proton CT (PRaVDA project) scanner developed within the UK and tested at iThemba LABS, Cape Town
- Proton CT demonstrators also been demonstrated by groups in US, Italy & Japan
- Requires low flux, highest available energy, measurements of 10^5 individual proton histories for each of the 180 projections
- Even if full proton CT is problematic for centres to implement proton radiography could still be used for patient monitoring
- Would require Spot scanning accelerators to work in a low current mode -> R&D needed here
- Potential to utilise machine learning techniques developed at FBK for analysis of non-linear proton paths

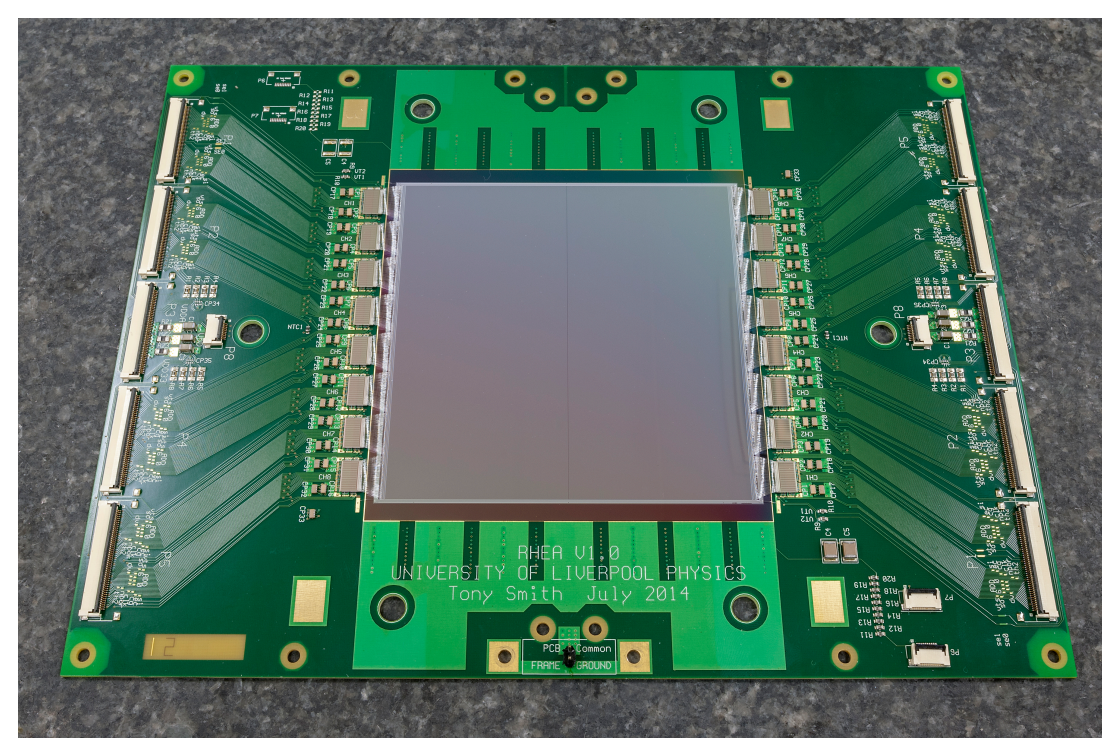
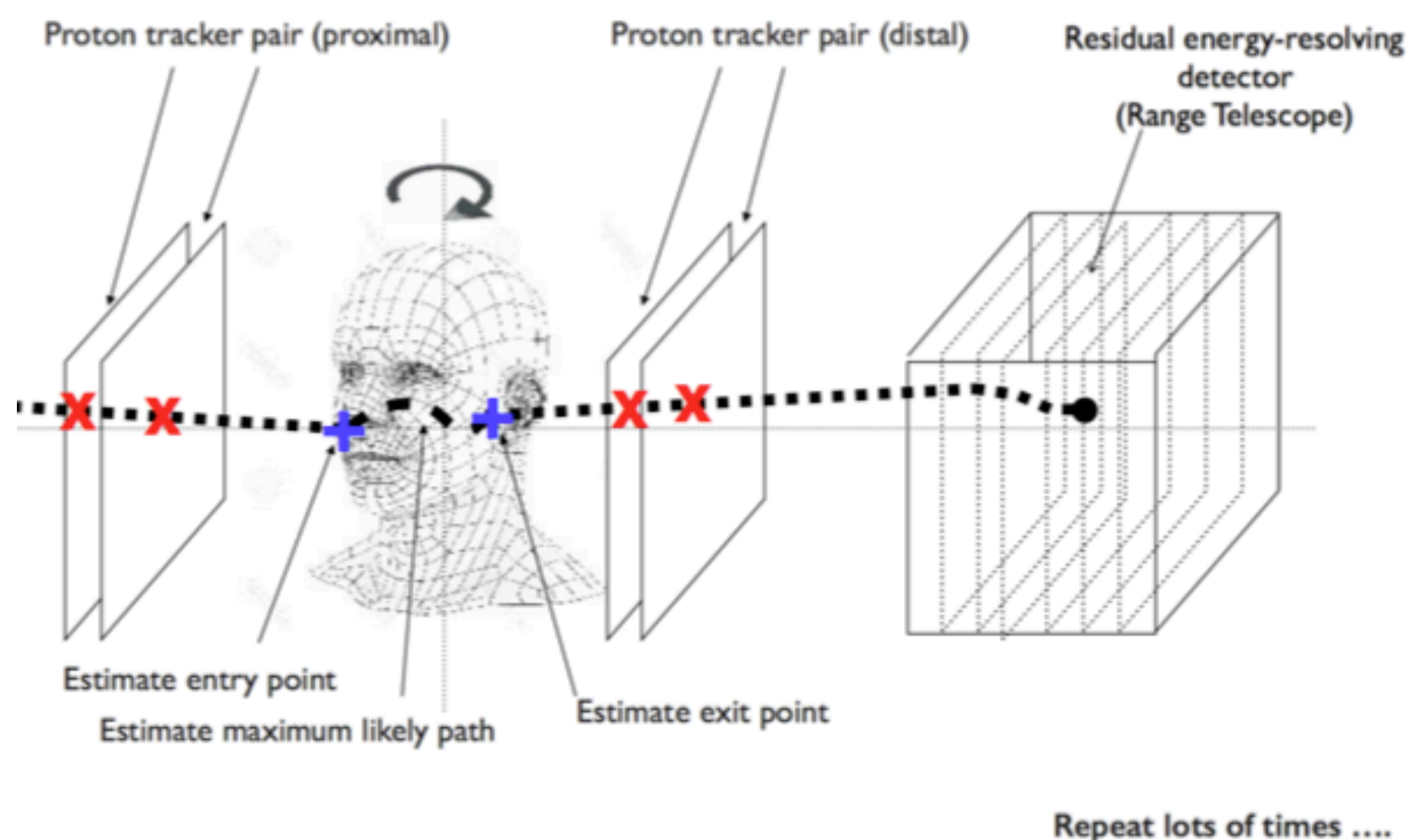

Silicon strip module developed for proton CT

Scattering and energy

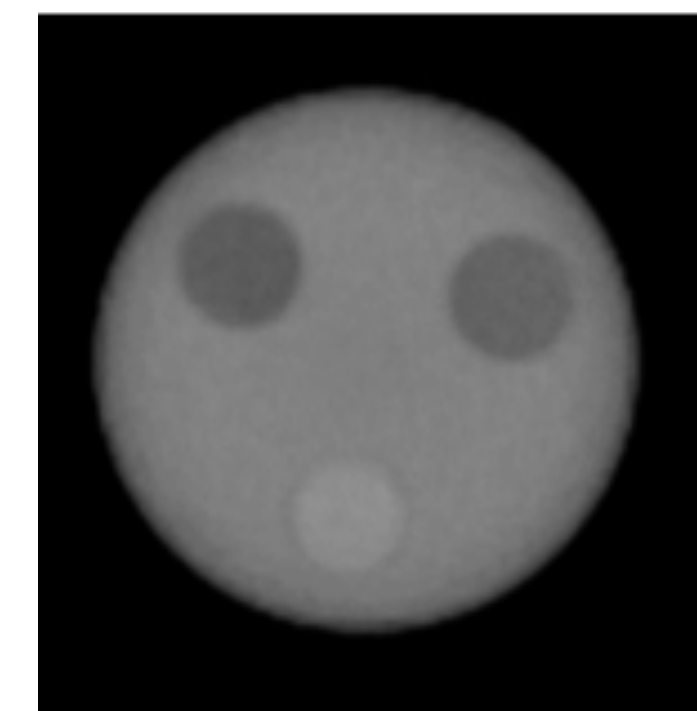

Scattering only

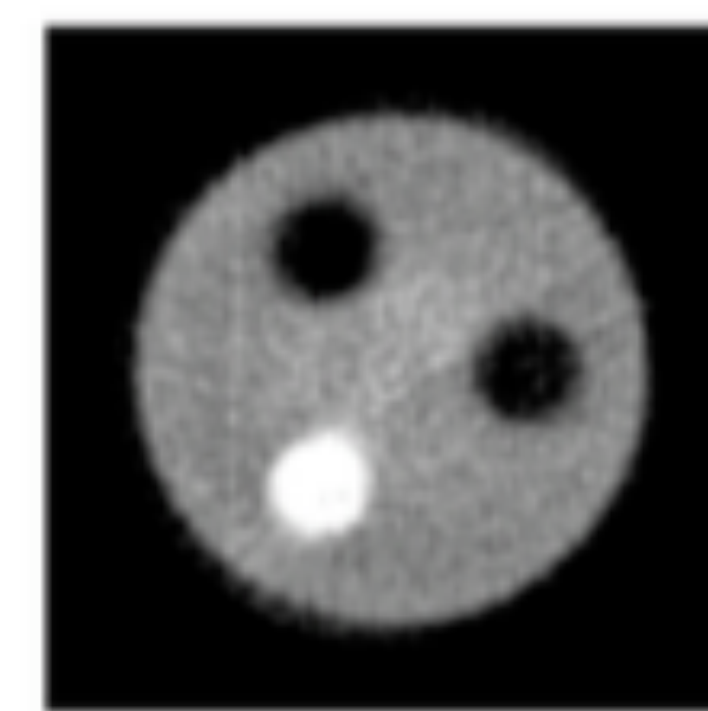

Resulting proton CT images with tissue equivalent inserts visible

Secondary vertex imaging

- Reconstruction of the trajectory of secondary particles allows a non-invasive way of imaging the beam path, range and dose in a patient
- This is typically proposed using so called ‘prompt’ gamma rays emitted by nuclei excited by the primary beam decaying back to their ground state
- Difficult to track gamma rays, most systems utilise heavily collimation or a Compton camera which result in loss of position/energy resolution and require large statistics
- Secondary protons have also been discussed as a way of range finding for proton therapy (<https://doi.org/10.1038/s41598-019-38611-w>)
- Ion therapy e.g. with ^{12}C presents an opportunity here -> projectiles have much greater momentum and mass therefore secondary particles will be both more numerous and energetic, so called ‘Interaction Vertex Imaging’ (IVI)
- **Silicon tracking detectors have the potential to be used for this application**

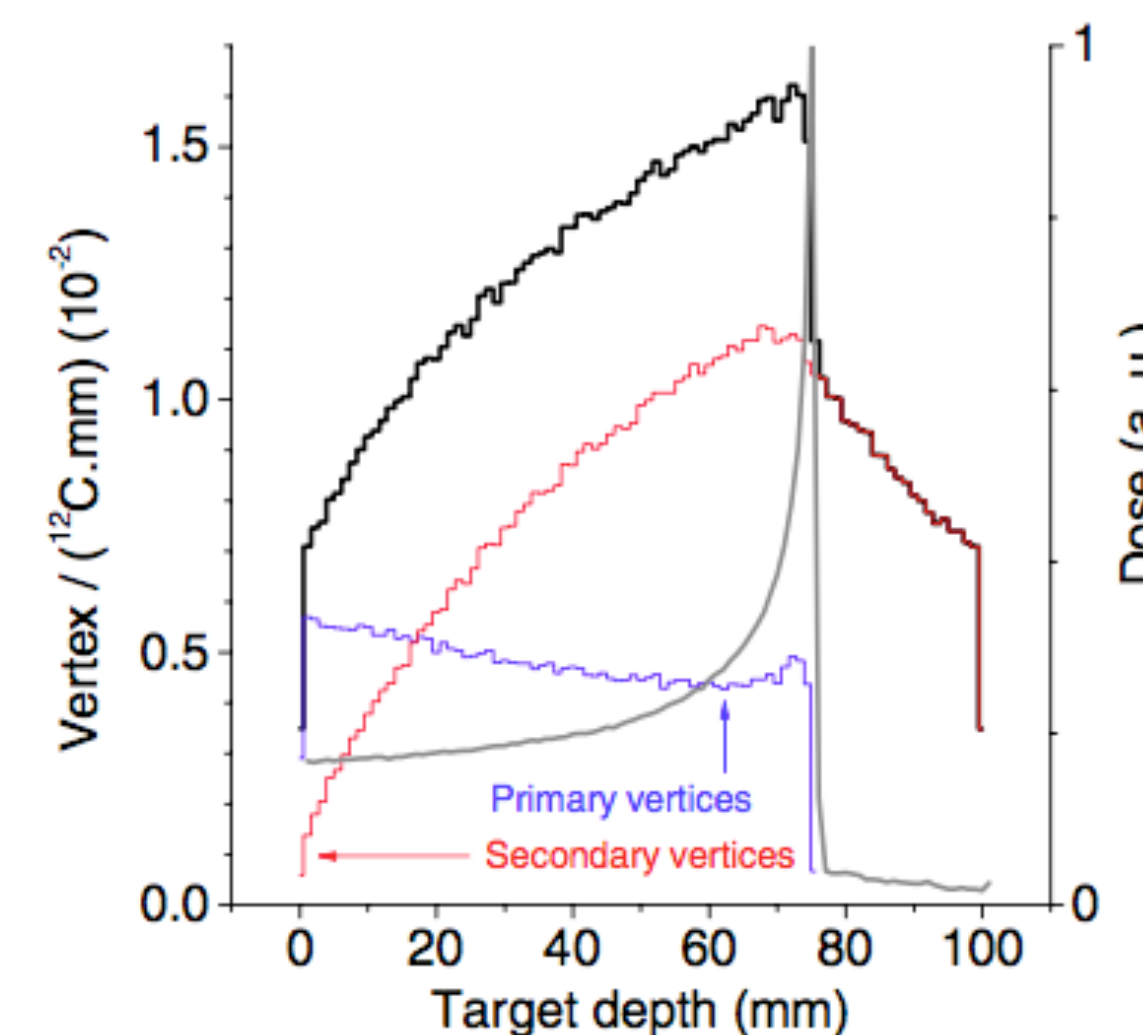
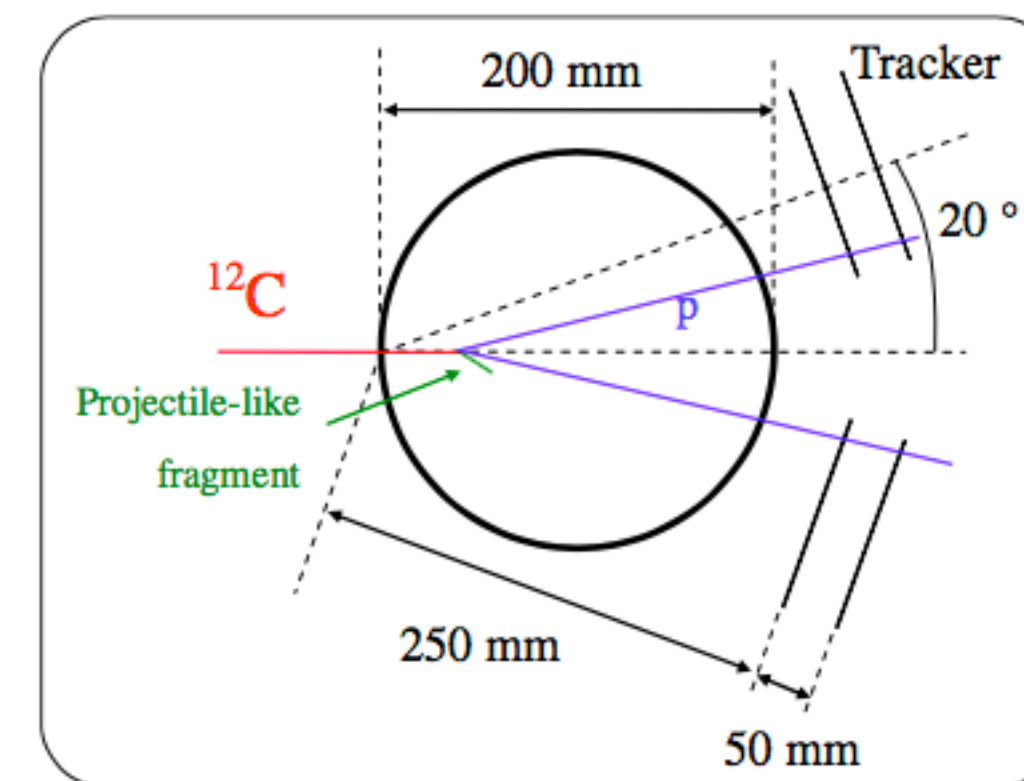

P Henriquet et al 2012 Phys. Med. Biol.
57 4655



- Flash therapy uses doses rates in excess of 30 Gy/s generating a more effective treatment in a way nobody seems to fully understand yet (<https://www.ncbi.nlm.nih.gov/pmc/articles/PMC6979639/>)
- Challenges for existing accelerators installed
- Challenges for instrumentation that is used to operating at lower fluences
 - Radiation damage (detector and electronics)
 - Saturation of electronics
 - Single event effects / upsets
 - Larger backgrounds in which to measure
- Presents a greater need for in-situ range monitoring (more can go wrong)
- Potential developments....
 - Charge integrator -> doesn't measure single particles and is low cost and rad hard
 - CMOS pixel detectors -> 2x positioned in beam halo, reconstruction of central beam spot

Beam halo measurement at CCC

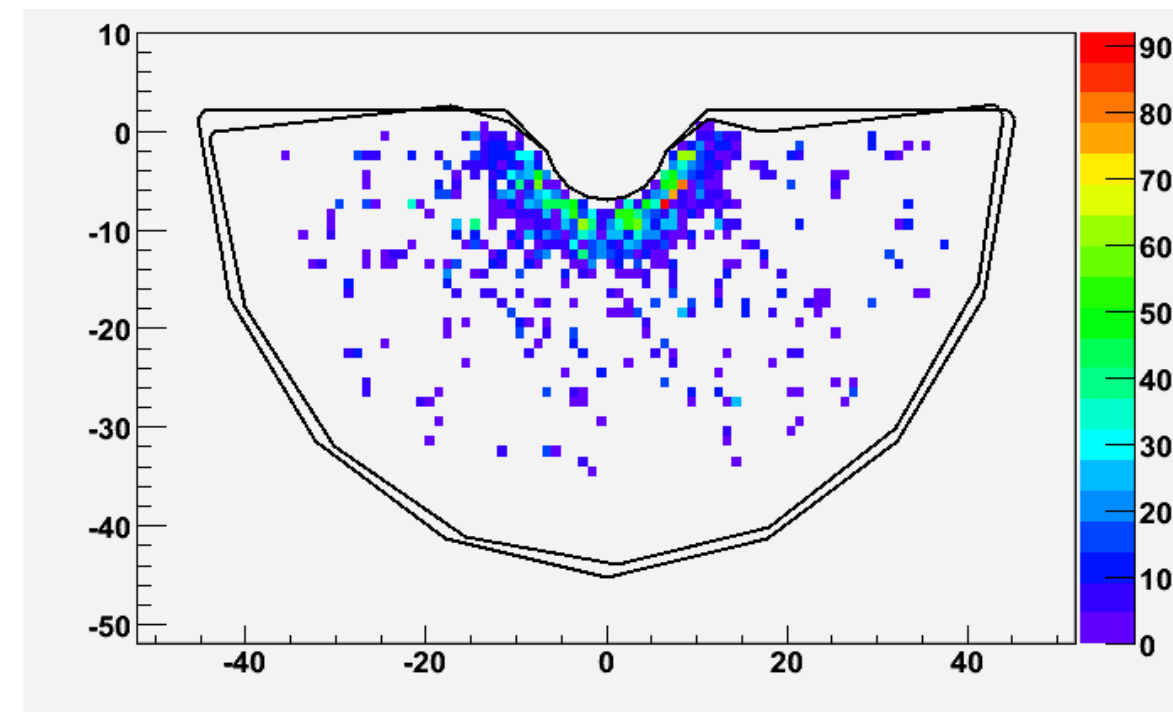



Radiobiology with elephants?



science & innovation
Department:
Science and Innovation
REPUBLIC OF SOUTH AFRICA

Research on tumor-suppressor gene:
“What can we learn from African elephants?”



Why do elephants develop less cancer than humans?

Evolution has fine-tuned elephants to make them cancer resistant



Elephants: 20 copies of tumor-suppressor gene

Humans: Only 1 copy of tumor-suppressor gene

Blood samples of African elephants are exposed to radiation at iThemba LABS and the effects are compared to samples from humans

In collaboration with: **GSI**
GSI Helmholtzzentrum für Schwerionenforschung GmbH

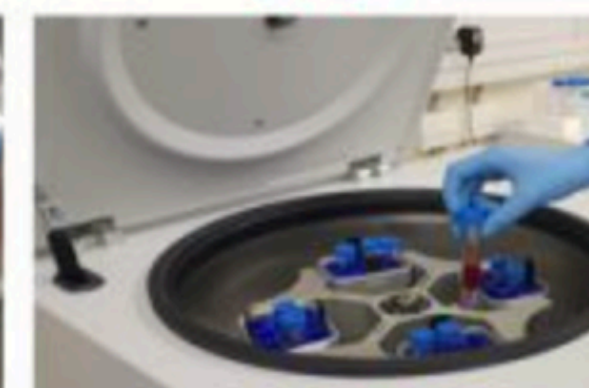

Ultimate goal: Design a drug that duplicates the effect of the tumor-suppressor gene to prevent and treat human cancer

Elephant blood samples in the biology laboratory @iThemba LABS





Particle therapy facilities in clinical operation

Proton Carbon Cumulative sum

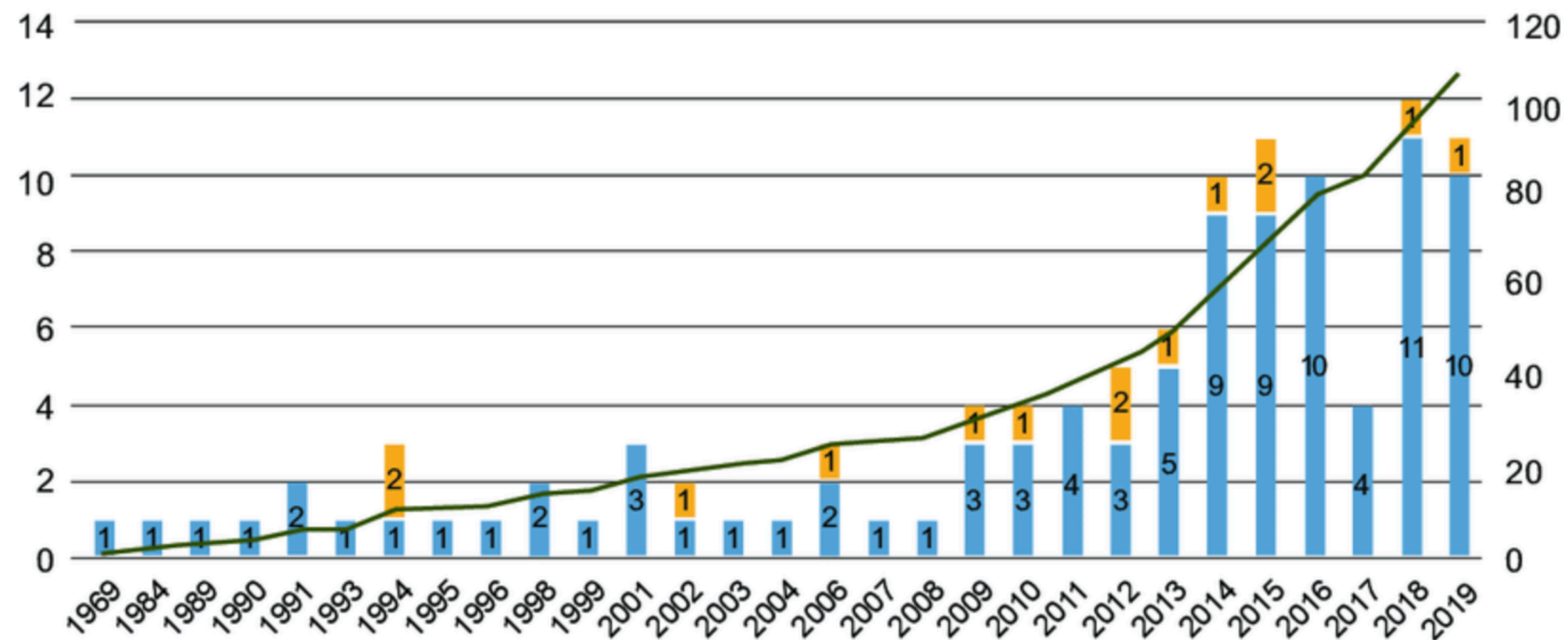

- Many centres under construction worldwide but still dominated by Northern hemisphere
- Increase in carbon ion facilities and also facilities that have multiple ion species available

Particle Therapy Centers Worldwide: 86

(in operation by March 2019)

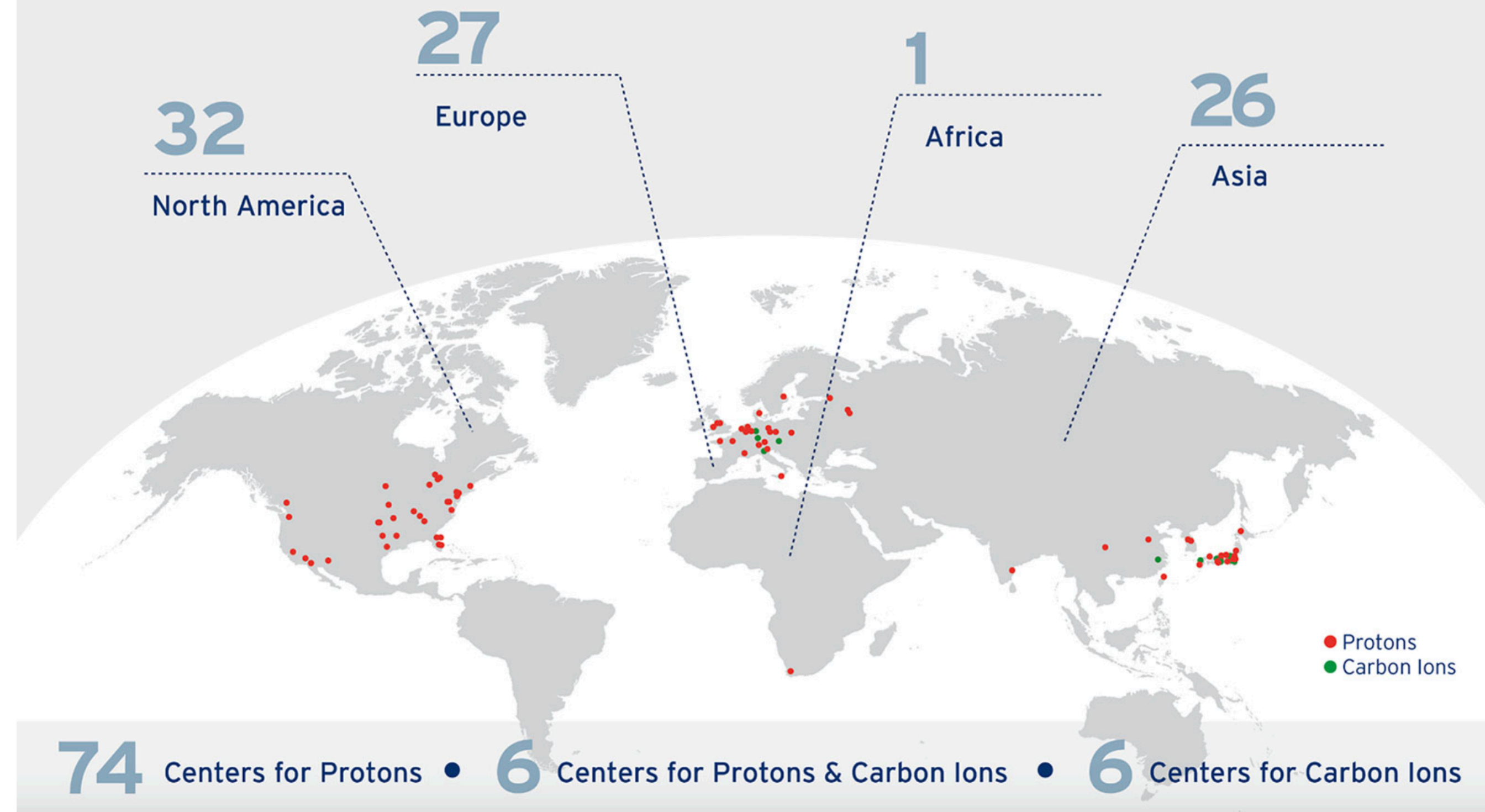



Ion Therapy Research Facility – the ambition

HOW

- A compact, single-site national research infrastructure delivering very high dose rates
- Protons and beyond, at energies sufficient for both in-vitro and in-vivo studies
- Consider technical options, with different risk profiles

PROPOSED PLAN

- Conceptual design of layout, cost and operation of a research facility
- Develop innovative laser-plasma technology, building upon world-leading expertise within the LhARA collaboration
- Develop innovative end-station designs, building on existing UK expertise in proton radiobiology research
- Collaborative agreement with CERN allows us to benefit from enormous experience and expertise in accelerator technology and successful projects

Closer to home in the UK....

<https://indico.stfc.ac.uk/event/668/contributions/4320/attachments/1494/2626/1272-pa1-pm-prs-0016-v0.1%20EndStationMtg1%20ITRF%20Owen.pdf>

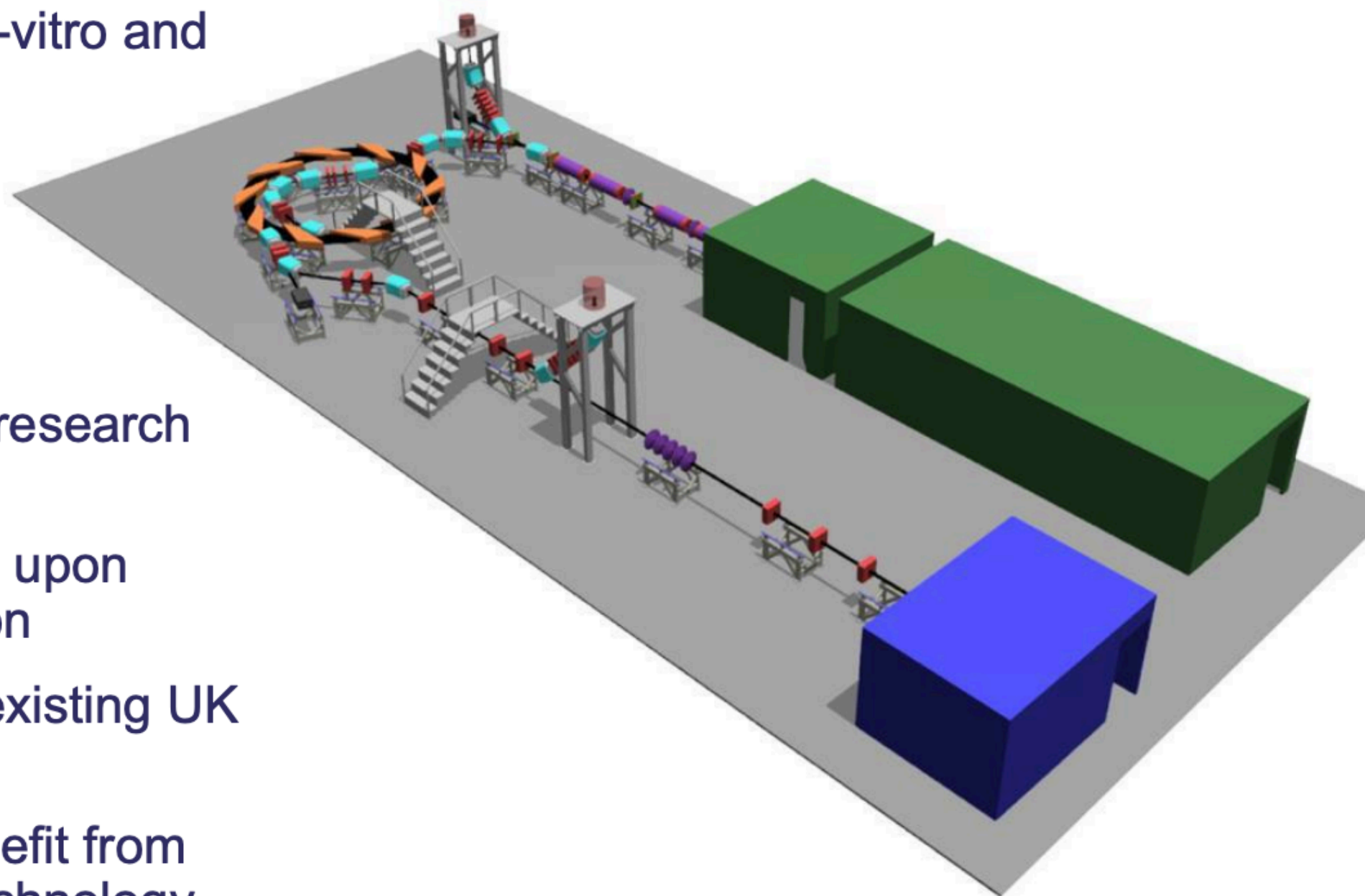



- Physics has always had a close relationship to medical applications
- X-ray radiotherapy has come along way since it's conception and has enjoyed considerable improvements thanks to the collaboration of physicists and engineers with clinicians
- Despite a larger cost, particle therapy is on the rise around the world due to the superior dose distribution and additional treatment modalities
- Developments of the sort made for x-ray radiotherapy ie IMRT need to be developed for particle therapy to ensure the maximum benefit from the physics is transferred to patients
- Many new centres for proton and ion therapy are under construction worldwide and with them lots of interesting instrumentation challenges ahead!

