

# What I will be talking about

---

- Week 1: mechanical structures
  - Session 1: Purpose of structures, track-based alignment, requirements for positioning and stability, loads (vibration, thermo-mechanical, etc.)
  - Session 2: 1D oscillator, Miles' equation, vibration studies (base vibration and air flow), structure design examples
- Week 2: Thermal management
  - Session 1: Silicon systems cooling requirements, sensor temperature and runaway, prediction methods
  - Session 2: Heat transfer, thermal path design, thermal conductivities of structural and interface materials, cooling technologies (air, monophasic, evaporative), evaporative cooling systems (emphasis on CO<sub>2</sub>), evaporator design (incl. microchannels), prediction methods and performance verification, engineering aspects
- A lot of stuff is from a review article I wrote some time ago:
  - G. Viehhauser 2015 JINST 10 P09001, doi:10.1088/1748-0221/10/09/P09001
  - Also has lots of references

# Thermal Management I

Georg Viehhauser

# Why do we need cooling?

---

## 1. Remove heat

- Front-end electronics
  - Can depend on configuration/trigger rates/etc.
  - At hadron machines: order W/cm<sup>2</sup> (pixel), 100 mW/cm<sup>2</sup> (strips)
- Sensor leakage power
  - Does depend on radiation damage and temperature
  - Order several 10 mW/cm<sup>2</sup>

## 2. Keep module cold (<< 0°C)

- Thermal stability
  - If too hot, leakage power can exceed removal capacity and temperature rises more → system runs away
- Limit detrimental annealing effects of radiation damage
  - Sensor technology dependent
- Limit HV current
  - Limit size and cost of supplies
- Limit shot noise
  - Shot noise depends on leakage current  $ENC_{shot}/[e] \approx \sqrt{12 \left[ \frac{1}{\text{nA} \cdot \text{ns}} \right] I \tau}$

Two different parameters, but linked through temperature-dependent leakage current

# What happens if you get it wrong?

---

- Failure to remove the heat generated can lead to thermal damage to the system
  - In practice usually well protected against overheating by temperature-dependent interlocks
  - Interlocks should be placed close to biggest heat sources and at locations where failure of heat removal manifests early
  - Note that response times can be short (see later)
- But even if you protect your system against instantaneous damage, the performance of your system can be compromised
  - In practice, for regular operation the power which can be generated in the system is limited by power supplies
  - Response to intolerably high currents will be reduction of bias voltage
  - Ultimately, in the long run failed thermal management results in reduced SNR, up to the point where system does not provide useful data any more

# Radiation damage

---

- Radiation damage manifests itself in three ways:
  - Change of the doping concentration → change of depletion voltage
  - Creation of recombination/generation centres → increased leakage current
  - Charge trapping → deterioration of charge collection efficiency.
- Non-Ionizing Energy Loss (NIEL) hypothesis:
  - Any radiation-induced effect can be expressed in terms of an equivalent particle flux and radiation damage scales with this flux
  - Usually flux given in equivalent flux of 1 MeV neutrons
- Radiation damage can also be caused by ionizing energy loss (IEL), but the results of this damage mode have limited relevance for thermal management
- All radiation damage effects are subject to temperature dependent annealing processes
- Models describing radiation damage effects and their annealing behaviour have been developed (for example Sheffield or Hamburg models)
  - Excellent agreement with the behaviour of silicon systems in high radiation environments

# Leakage current and doping concentration vs dose and T

- Leakage current typically increases linearly with NIEL dose, and decreases with annealing
- Doping concentration initially decreases (beneficial annealing), but increases over longer time scales (reverse annealing)
  - In practice this requires increasing the bias voltage for depletion
  - To limit this usually sensors need to be kept cold (about 0°C or colder) at all times
  - Sensor type dependent: In n-in-p sensors high field stays next to electrodes → provide useful signals even if not fully depleted → requirement to keep cold at all times relaxed

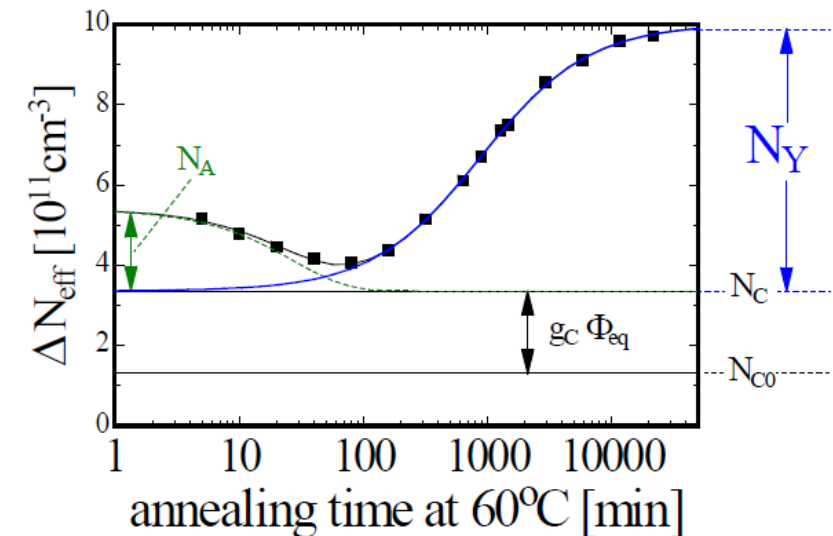
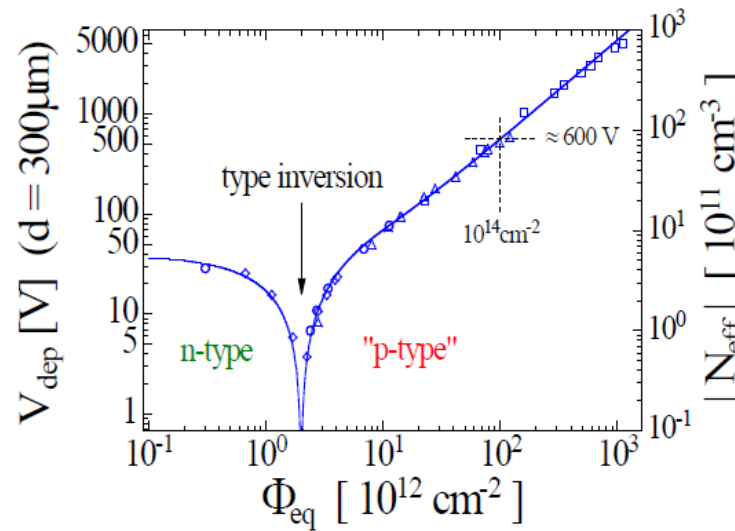
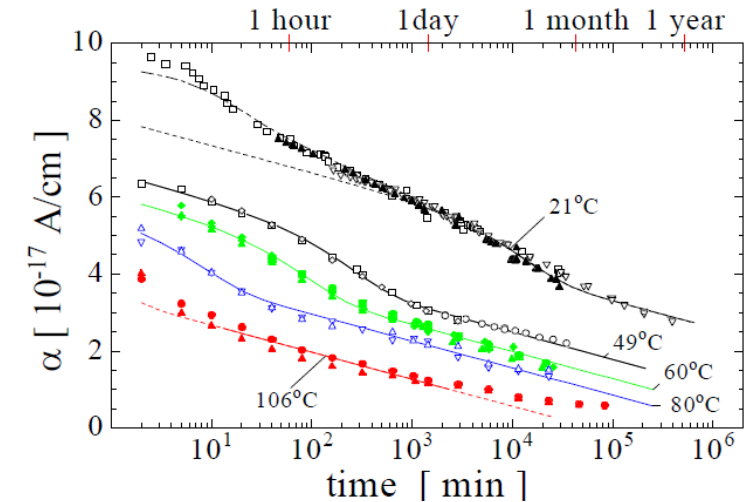
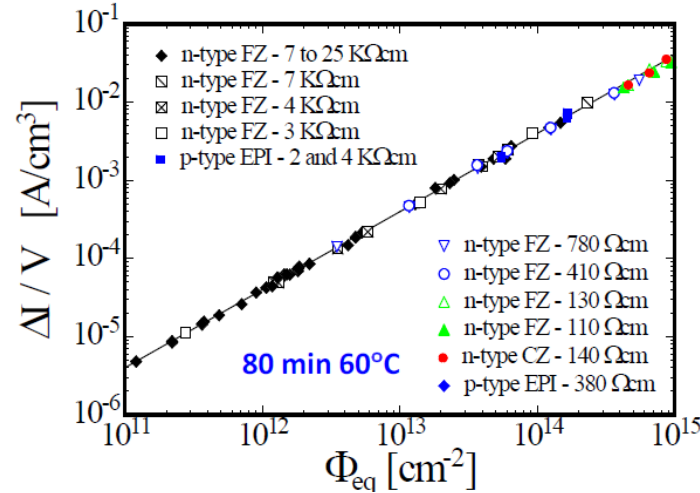

# Leakage current – temperature dependence

---

$$Q(T_S) = Q_{ref} \left( \frac{T_S}{T_{ref}} \right)^2 \exp \left( T_A \left( \frac{1}{T_{ref}} - \frac{1}{T_S} \right) \right)$$

Q here is heat generated  
 $Q = V \times I(T_S)$ , assuming V constant

- For scaling of leakage current (power) from reference current (power)  $Q_{ref}$  at a reference temperature  $T_{ref}$
- Activation temperature  $T_A = \frac{E_g}{k_B} \approx 7000$  K
  - Effective energy gap for carrier generation  $E_g \approx 1.2$  eV
  - More than actual band gap (1.12 eV), see A. Chilingarov, 2013 JINST 8 P10003
- Rule of thumb: leakage current (power) doubles for every  $\sim 7^\circ\text{C}$
- $Q_{ref}$  depends on the sensor material and design, usually known from measurements

# Sensor temperature and thermal stability

G. Beck, G. Viehhauser, NIM A 618 (2010) 131–138

- Minimal model: we model the thermal behavior of a module as a linear network

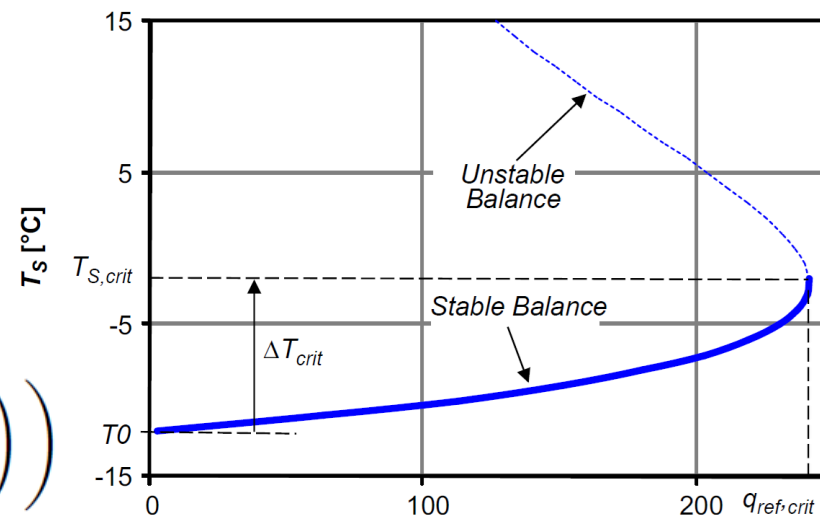
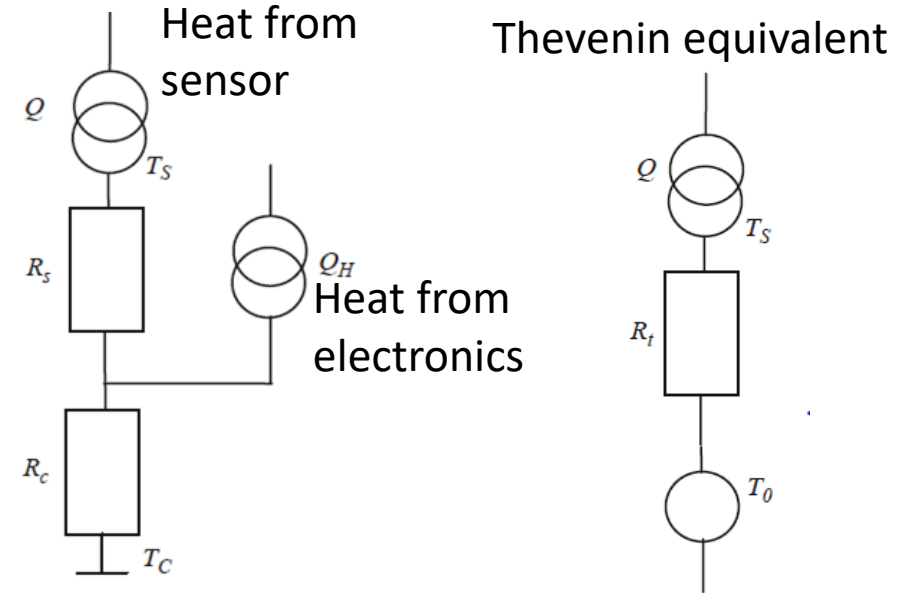
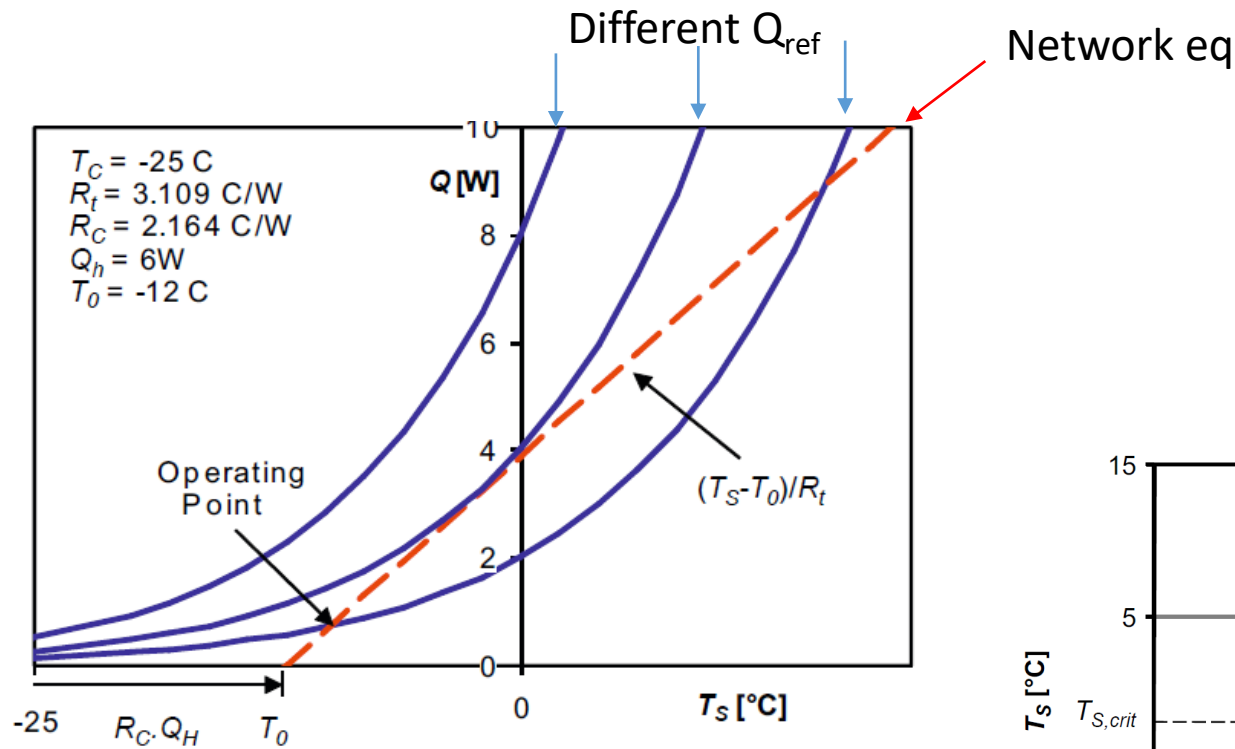

Sensor temperature Curve (aka “thermal runaway curve”)

Typically plot max  $T_S$  from FEA vs  $Q_{ref}$

$$Q_{ref} = \frac{(T_S - T_0)}{R_t} \left( \frac{T_{ref}}{T_S} \right)^2 \exp \left( T_A \left( \frac{1}{T_S} - \frac{1}{T_{ref}} \right) \right)$$

# Analytic model of sensor temperature

FEA is time consuming, so use minimal model

1. Find values of thermal impedances from a limited number of FEA runs (need as many runs as thermal impedances in model)
2. Then calculate behavior over whole parameter range, and in particular the critical parameters from analytical expressions

$$T_{S,crit} = T_0 + \left( \sqrt{T_A^2 + 4T_0^2} - T_A \right) / 2 \quad \Delta T_{S,crit} \equiv T_{S,crit} - T_0 \approx T_0^2 / T_A$$

$$Q_{ref,crit} = \frac{T_A T_{ref}^2}{(T_A + T_0)^2} \exp \left( T_A \left( \frac{1}{T_{S,crit}} - \frac{1}{T_{ref}} \right) \right) / R_t$$

3. Critical parameters for given sensor power  $Q_{ref}$

$$T_{S,crit} \approx \frac{T_{ref}}{1 - \frac{T_{ref}}{T_A} \ln \left( \frac{T_{ref}^2}{R_t Q_{ref} T'_A} \right)} \quad T_{0,crit} = T_{S,crit} \left( 1 - \frac{T_{S,crit}}{T'_A} \right) \quad T_{C,crit} = T_{0,crit} - R_c Q_H$$

Critical cooling temperature

with  $T'_A = T_A + 2T_S \approx T_A + 500 \text{ K}$

# The whole picture

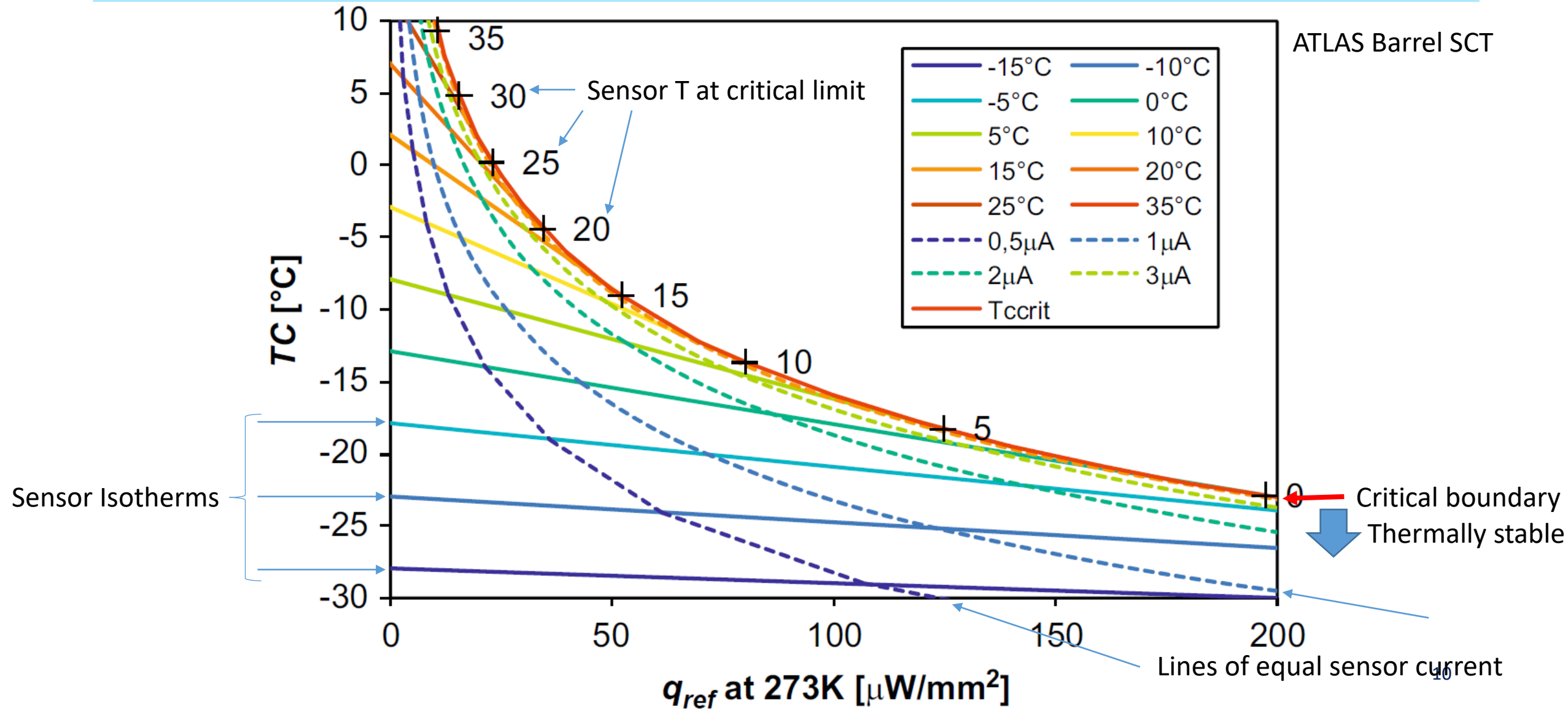

# How do we get the impedances for the minimal model?

- For the simple network model so far there are two resistances required ( $R_c$  and  $R_s$ ), which can be extracted from two FEA runs
  - Usually take  $Q_{ref} = 0$  to get  $T_0$  and one other small  $Q_{ref}$
- But there is one question: which sensor temperature should we take? In a 3D FEA the sensor temperature is not uniform
  - Traditionally, people always plot the max sensor temperature
  - However, it turns out, the best estimate of critical parameters is obtained if average sensor temperature is taken

ATLAS ITk barrel strip sensor

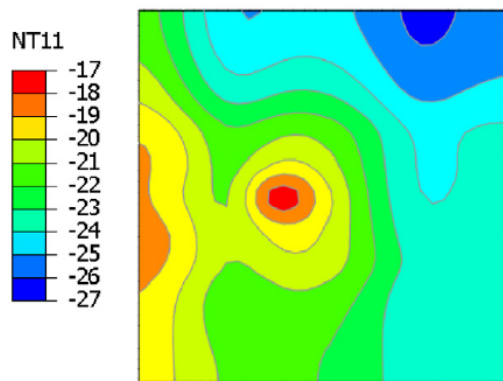

Dashed line is  $T_{C,crit}$  from minimal model

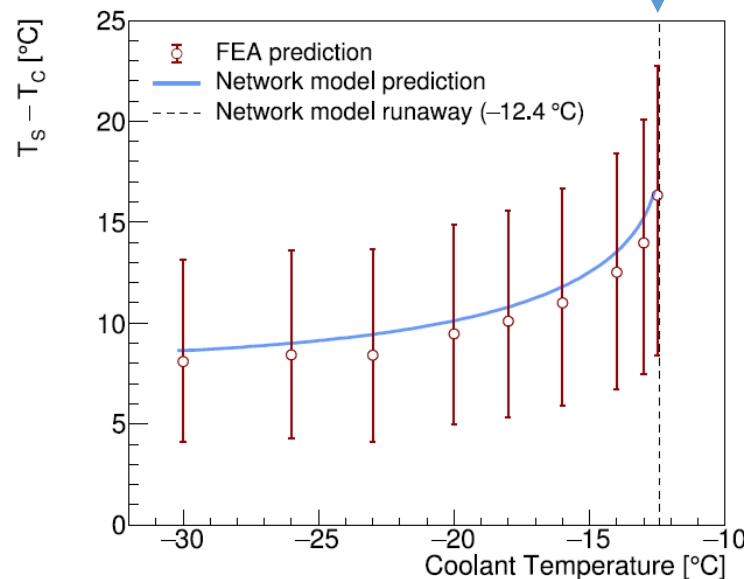

Error bars give range of sensor temperatures from FEA

Last datapoint is largest  $T_c$  for which a stable solution was found with FEA

# A more complex example

Beck, Brendlinger, Chen and Viehhauser, NIM A 969 (2020)164023

- In the ATLAS ITk strip system we have additional non-linear temperature dependent electronics elements
  - Power converters (FEAST) with varying efficiency
  - Front-end chips with TID-dependent leakage currents
- Temperature and generated power linked in complex way
- Impossible to calculate using FEA

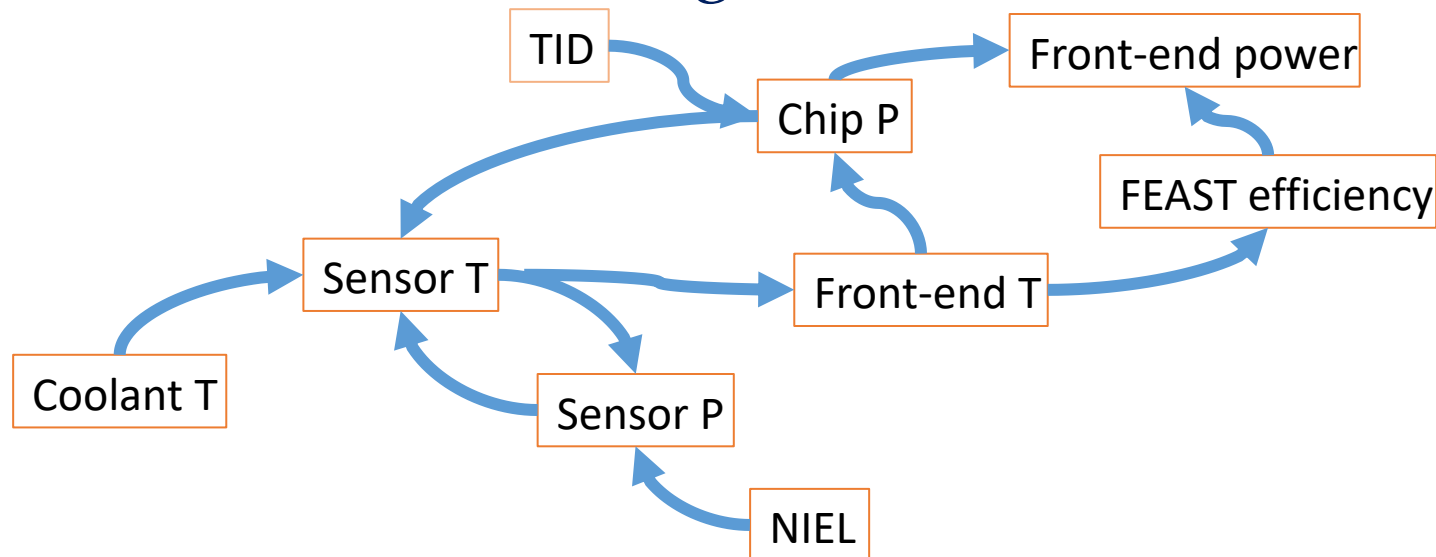

# Thermo-electrical model for the ITk strips

- Two connected networks, one electrical (to determine power), one thermal (to determine temperatures)
- Non-linear elements have been parametrized from measurements
- Thermal impedances from thermal FEA (more impedances so a more runs)
- Done this for every month in the expected 14 years of operation (with realistic luminosity profile)
- System of equations is not solvable analytically, but numerically using Mathematica or Python

Electrical network

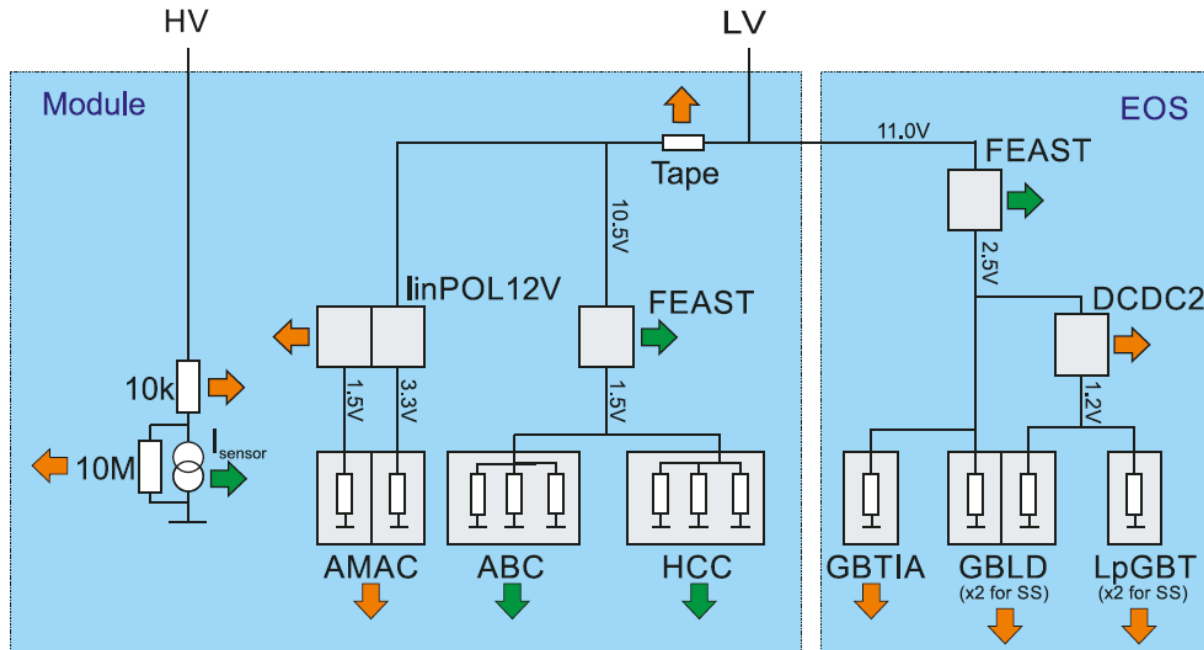

Thermal network

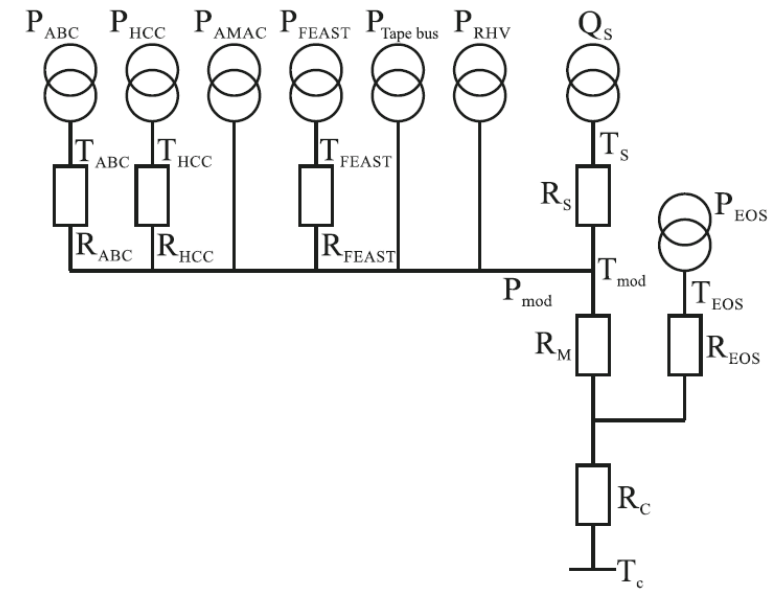

# Output examples

Safety factors [%]	Fluence	50	50	50	50	50	50
	$R_{\text{HBBR}}$	0	20%	20%	0	20%	20%
	$I_D$	0	10%	10%	0	10%	10%
	$I_A$	0	5%	5%	0	5%	5%
	$R_{\text{HAPL}}$	0	10%	10%	0	10%	10%
$V_{\text{max}}$ [V]		500	500	500	500	500	500
TID parametrization		Nominal	Pessimistic	Pessimistic	Nominal	Pessimistic	Pessimistic
Cooling [°C]		Ramp <sup>1</sup>	Ramp	Flat -35°C	Ramp	Ramp	Flat -35°C
Pre-radiation		8 Mrad	8 Mrad	8 Mrad	0	0	0
$P_{\text{total}}$ min/max [kW]	Excl. services	44.7/46.1 (103%)	48.6/50.3 (103%)	47.7/49.8 (104%)	45.0/48.0 (107%)	48.9/53.3 (110%)	47.7/56.3 (118%)
	With type I (cooling system power)	47.1/48.5	51.4/53.1	50.4/52.5	47.4/50.8	51.7/56.9	50.4/60.4
	With all services +PS (wall power)	76.8/79.1	84.4/87.1	83.2/85.9	77.5/83.6	85.3/94.8	83.2/101.9
Max $P_{\text{HV}}$ [kW]		2.0	2.4	2.4	2.0	2.4	2.4
Max service power [kW]		17.3	19.6	18.9	18.9	22.3	25.2
Max power per module (total/LV only/HV only) [W]	B0	6.5/5.7/0.43	7.3/6.4/0.62	7.2/6.1/0.62	7.0/6.4/0.43	8.4/7.5/0.62	10.3/9.2/0.62
	B1	6.4/5.7/0.31	7.1/6.3/0.43	7.0/6.1/0.43	6.9/6.3/0.31	8.0/7.2/0.43	9.1/8.2/0.43
	B2	3.6/3.2/0.17	3.9/3.4/0.20	3.9/3.4/0.20	3.8/3.4/0.17	4.4/3.8/0.20	4.6/4.1/0.20
	B3	3.5/3.2/0.13	3.9/3.4/0.16	3.8/3.4/0.16	3.7/3.4/0.13	4.2/3.7/0.16	4.3/3.9/0.16
Power per module before irradiation (total/ LV only/HV only) [W]	SS	6.2/5.6/0.02	6.9/6.1/0.02	6.6/5.9/0.02	6.2/5.6/0.02	6.9/6.1/0.02	6.6/5.9/0.02
	LS	3.4/3.1/0.02	3.8/3.3/0.02	3.7/3.2/0.02	3.4/3.1/0.02	3.8/3.3/0.02	3.7/3.2/0.02
Hybrid current (10 ABC + 1 HCC) (max/min) [A]		1.16/1.16	1.24/1.24	1.24/1.24	1.30/1.16	1.46/1.24	1.75/1.24
Tape LV B0/B2 (no EOS)	Max P [W]	78.2/43.2	85.8/46.5	83.0/45.8	87.4/46.5	101.4/51.6	123.4/55.7
	Max $\Delta V$ [V]	0.60/0.67	0.72/0.78	0.70/0.77	0.67/0.71	0.85/0.87	1.03/0.93
	Max I [A]	7.2/3.9	7.8/4.2	7.6/4.2	8.0/4.2	9.2/4.7	11.0/5.0
Max $I_{\text{HV}}$ per module [mA]		0.80	1.16	1.16	0.80	1.16	1.16
Max HV voltage drop [V]		8.4	12.1	12.1	8.4	12.1	12.1
Max sensor Temperature B0 (EOS/normal) [°C]	Y1	8.5/6.7	11.3/8.9	-24.0/-26.4	8.5/6.7	11.3/8.9	-24.0/-26.4
	Y14	-26.3/-28.1	-23.2/-25.8	-23.2/-25.8	-26.3/-28.1	-23.2/-25.8	-23.2/-25.8
	Max	8.7/6.9	11.7/9.2	-23.2/-25.8	9.2/7.3	12.7/10.1	-19.2/-21.8
Max $T_{\text{sensor}}$ [°C]		36.5	49.5	10.3	39.2	55.9	38.9
Max stave power [W]	B0	168	185	183	182	212	253
	B1	165	182	179	178	203	227
	B2	92	100	99	98	108	115
	B3	91	99	98	96	106	109
Max LV round trip V drop from PP2 [V] (B1/B3)		2.2/2.2	2.5/2.5	2.4/2.4	2.5/2.4	2.9/2.7	3.5/2.9
Max PP2 output voltage [V] (B0/B2)		12.4/12.4	12.6/12.6	12.6/12.6	12.6/12.5	13.0/12.8	13.5/13.0
Max I per stave side (I in type I/II/III services) [A] (B0/B2)		7.4/4.1	8.0/4.4	7.8/4.3	8.2/4.4	9.4/4.8	11.3/5.2

- Numerical results
- Development plots

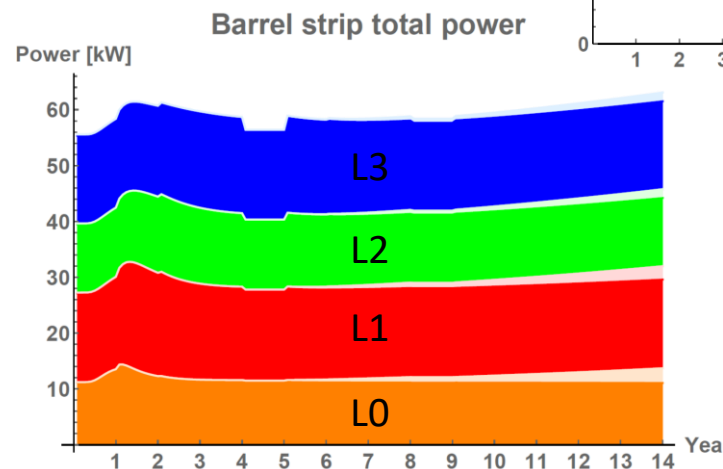
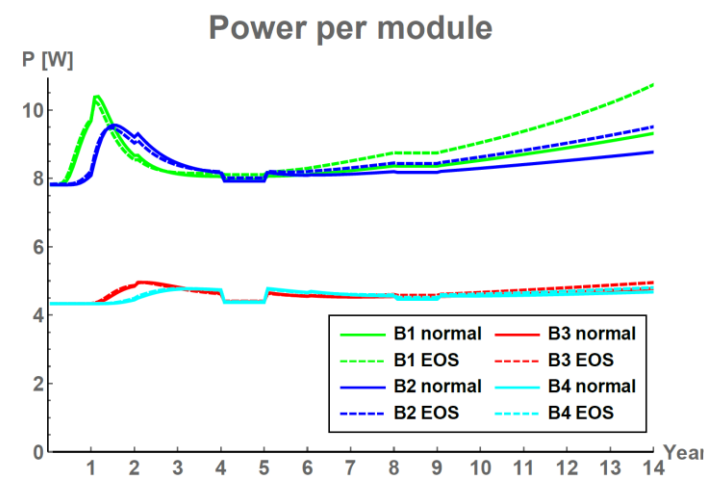

# Thermal response time

- Now let's push the analogy further:
- In electronics the time constant of a single RC circuit is given by  $\tau = RC$
- For our thermal network we can do the same by introducing a heat capacitance into the network (like a capacitor in an electrical network)
- The response time of the system is then given by  $\tau = RC$ , where R is our thermal impedance (in  $^{\circ}\text{C}/\text{W}$ ) and C the heat capacity (in  $\text{J}/^{\circ}\text{C}$ )
  - This time constant can of course also be found from dynamic FEA
  - It is typically in the order of a minute

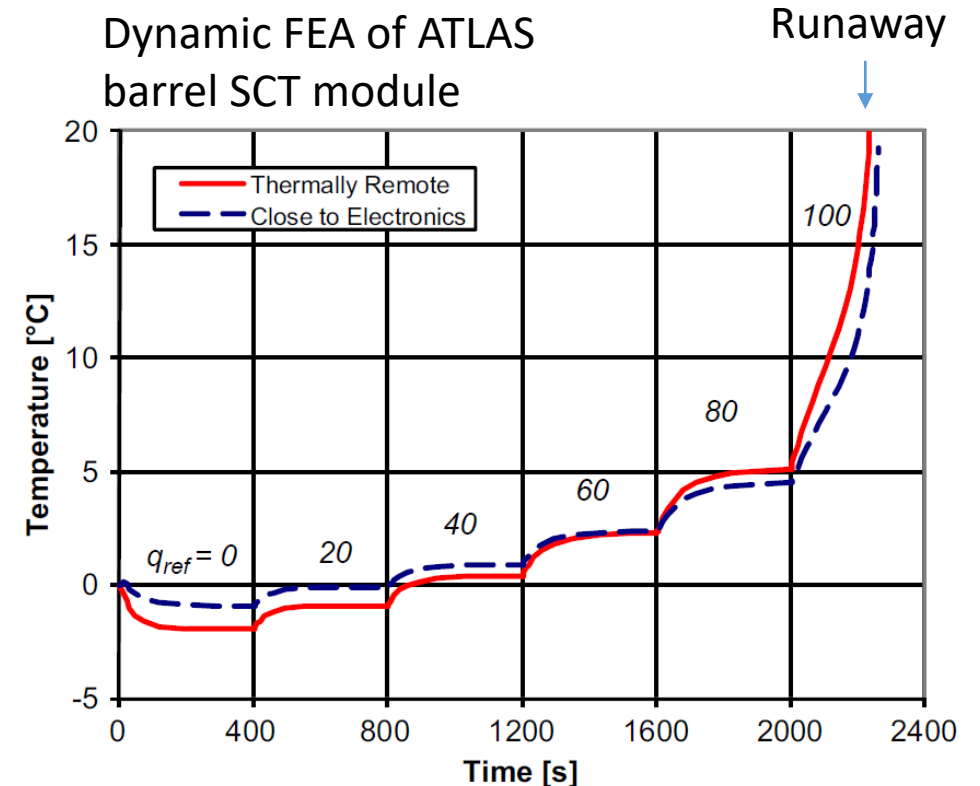

# Summary

---

- The purpose of thermal management is to
  1. Remove heat
  2. Keep temperatures low
- If you get it wrong there is the possibility of instant damage
  - But even if you protect against that, system performance is compromised
- A key feature is sensor leakage current
  - Small fraction of power to be removed, but temperature-dependent
  - Increases with radiation damage
- Accurate prediction of performance is time-consuming (3D FEA)
  - Simple network models can facilitate understanding
- Because thermal management is critical and non-trivial you need to understand your design (requirements, specifications, and safety margins)
  - Wildly slapping on safety factors is not the answer
  - Network models can be very useful for quick turn-around optimization

# Thermal Management II

Heat transfer & cooling systems

# Heat transfer

- How can we move heat?
    - Radiation
      - Limited capacity at terrestrial temperatures and typical area of silicon systems
      - Usually not relevant for silicon system thermal management (exception: space-based)
    - Natural convection
      - $j_Q = \alpha \Delta T$  with heat conductivity  $\alpha \approx 5 - 20 \text{ W/m}^2\text{K}$  (typical)
      - Again, not enough for silicon cooling, but often non-negligible parasitic heat transfer
    - Forced convection
      - Can be contained (fluid in pipes), or free (gas flow cooling)
    - Heat conduction
      - $\vec{j}_Q = -\kappa \vec{\nabla} T$
- These are the technically relevant types of heat transfer for silicon systems

Prime message: Heat does not move easily

# Heat conduction

- Critical performance parameter is thermal impedance, defined as ratio of the temperature gradient to heat transferred:  $R = \Delta T / j_Q$ 
  - Often people use the term figure-of-merit, which is the inverse
    - Nothing wrong with this, I just find thermal impedance more intuitive and directly useful (see later)
  - Some people then try to normalize this with the area
    - That's garbage, because the thermal impedance/figure of merit depends on the actual geometry, and does not generally scale with the area
- Structural elements often fulfil secondary role as heat conduction paths
  - Thermal impedance decreases with cross-section of the heat path
  - Need to reconcile low thermal impedance with minimizing the detector material causing multiple scattering
  - Use of high thermal conductivity materials is mandatory
- Usually some conductive path cannot be avoided: from the electronics/silicon to the local heat sink (typically cooling pipe)

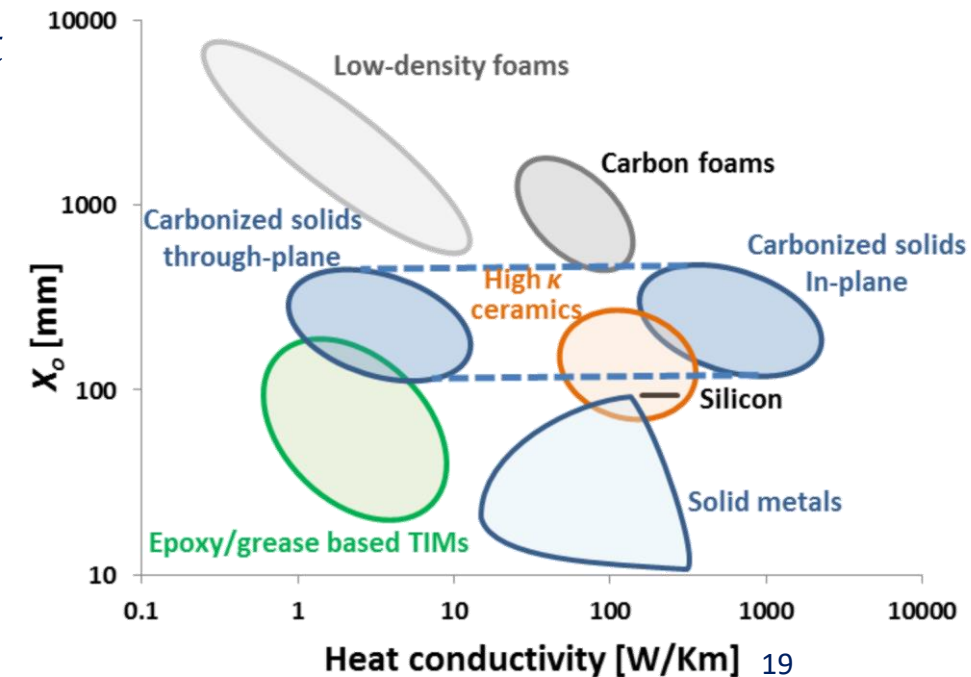

# Interface to mechanics

---

- We mentioned already:
  - Structural elements often are part of the heat path → optimize geometry and materials
  - Integration of cooling pipes (in particular microchannels) into structures
    - Examples: microchannels into silicon ladders (DEPFET), or Kapton tubes in composite structures (ALICE)
- Another important aspect: Cooling introduces thermal loads to structures
  - Because of different thermal expansion coefficients of the different materials in the system: structures will suffer temperature dependent deformations
  - To minimize these
    - Design symmetric structures
    - Mechanically decouple items with vastly different CTE (sliding connections, glue with low shear strength, etc.)
    - Minimize variations of
      - Coolant temperatures: This is mostly a control issue of the cooling system
      - Load variations: Keep power requirements constant (i.e. independent of trigger rate, run configuration etc.)

# Cooling pipes and thermal path topologies

- Because heat transfer by forced convection is much more capable than conduction heat path geometries tend to bring the heat sources (in particular sensors) closer and closer to the local heat sink (cooling pipe)

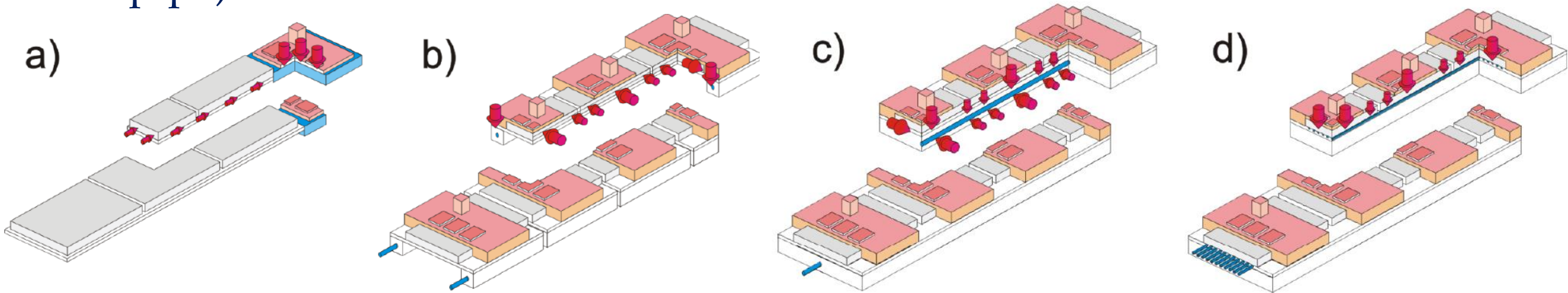

- The natural endpoint is to incorporate the cooling channels into the silicon (sensor and/or electronics): ‘micro-channels’
  - The difficulty here is how to connect the pipe segments from wafer to wafer

# Examples:

## ATLAS ITk strips

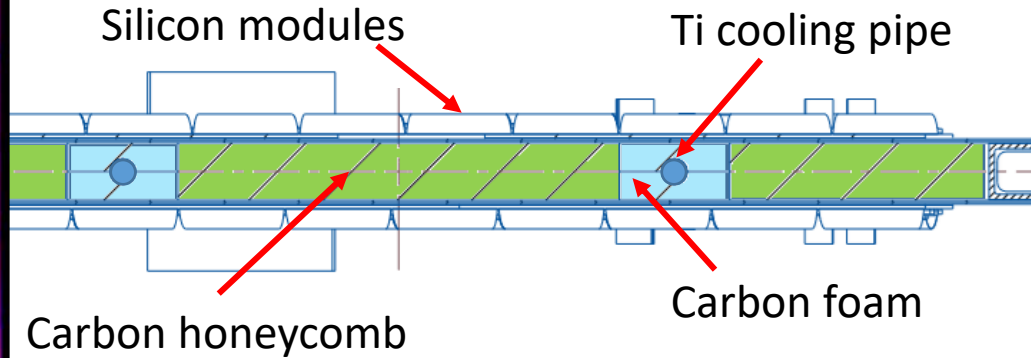

Approximate Thermal Resistance Contributions

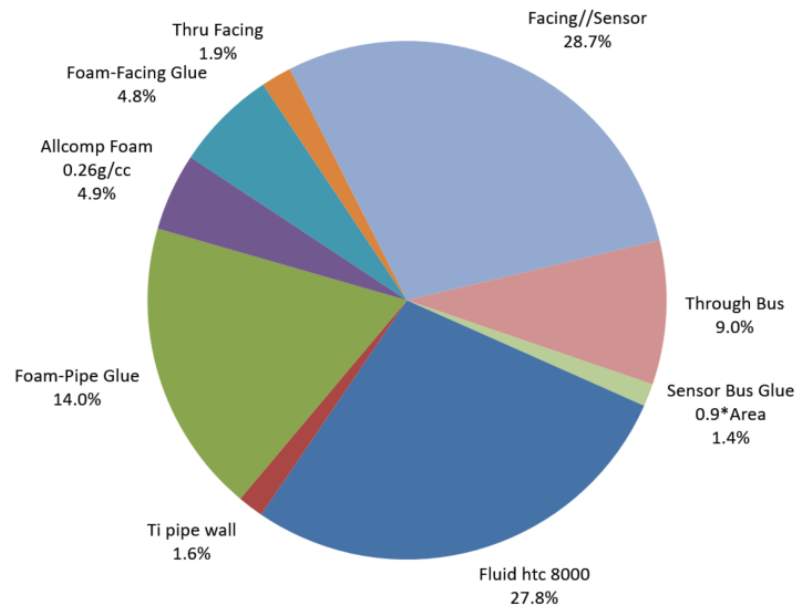

## LHCb VELO upgrade

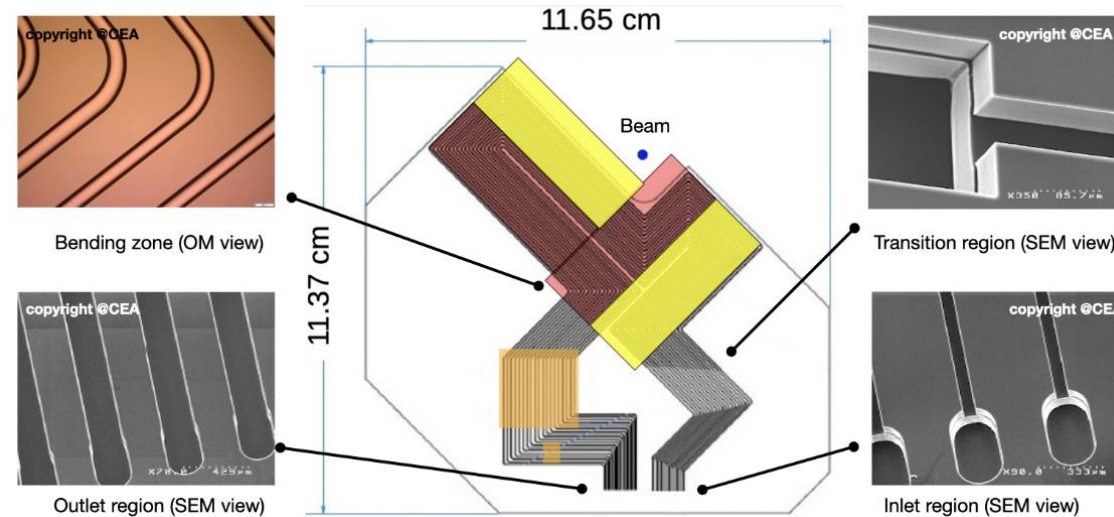
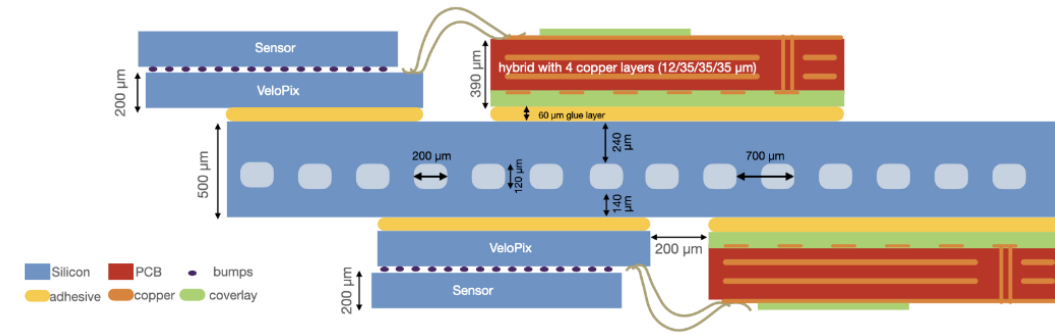

# Forced convection

---

- Best method to transport heat over large distances ( $> 0.1$  m)
  - Every large scale silicon system uses forced convection to transport heat from local heat sink at the detector to external heat sink
  - Usually this means that the forced convection system is closed, but that's not necessary, if the coolant is cheap and environmentally unproblematic
    - Examples: Air cooling, evaporative CO<sub>2</sub> cooling with a blow-off system
- Two main types:
  - Monophase
    - Can be liquid or gas
    - Required mass flow is given by amount of heat to be removed, the acceptable temperature increase through the system and heat capacity of the coolant
  - Evaporative
    - Coolant to the heat source is liquid, heat is absorbed as latent heat of evaporation, and return is (partly) vapour
  - (Something more exotic, but considered originally for the ATLAS SCT: binary ice)

# Monophase cooling: Liquids

---

- Requires pipes
- Pressure head defined by frictional pressure drop
- Coolant temperature on detector given by temperature of external heat sink +  $\Delta T$  due to detector load & parasitic heat flows into transfer pipes
  - Transfer pipes need to be insulated to limit parasitic heat load & outside condensation
- Coolant temperature along pipe is increasing due to finite heat capacity
- Heat transfer coefficient into monophase coolant is proportional to
  - Heat capacity of coolant and
  - Inverse of length scale of heat transfer (e.g. diameter of the cooling tube) and
  - Increases for turbulent flow
- H<sub>2</sub>O (water/glycol below 0°C) is a good coolant because of large heat capacity. But it's conductive, so leaks are not good. Use
  - 'Leakless' systems, with coolant at sub-atmospheric pressure, or
  - Inert fluids (e.g. C<sub>6</sub>F<sub>14</sub>)

# Monophase cooling: Gas

---

- Only applicable for low heat loads
  - Heat capacity and thermal conductivity small
- Nevertheless, has advantage of minimal material & no on-detector cooling components (pipes)
- Air (STAR PXL), argon/ethane (CDF SVX), nitrogen (BELLE II PXD) have been used
  - STAR: tested in detector mock-up dissipating 340W, resulting in  $\Delta T = 12^\circ\text{C}$  with air flow of 10 m/s (0.42 kg/s)
- Helium is attractive because of low mass, which also means high heat conductivity and specific heat capacity
- The biggest difficulty with air flow systems is designing and verifying the air flow, so that enough flow arrives at heat sources
  - Design simple air channels
  - And/or you need to 1:1 prototype the whole system as accurately as possible
    - This can be prohibitive in cost and time

# Example: STAR PXL

- First vertex detector at a collider experiment based on Monolithic Active Pixel Sensor technology
- 350 W total Si + drivers.  $\Delta T = 11\text{ }^{\circ}\text{C}$  with 10.4 m/s air velocity, confirming CFD estimate

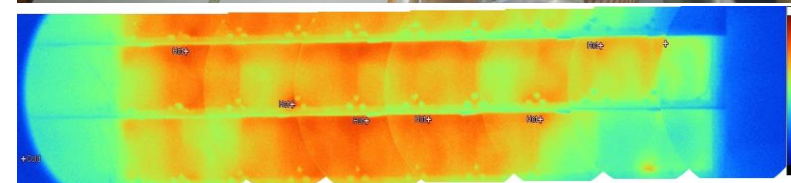
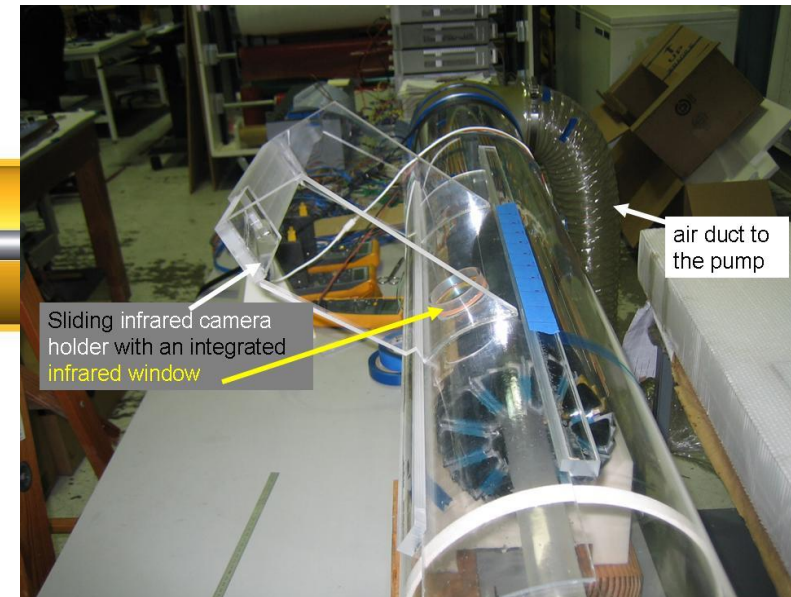
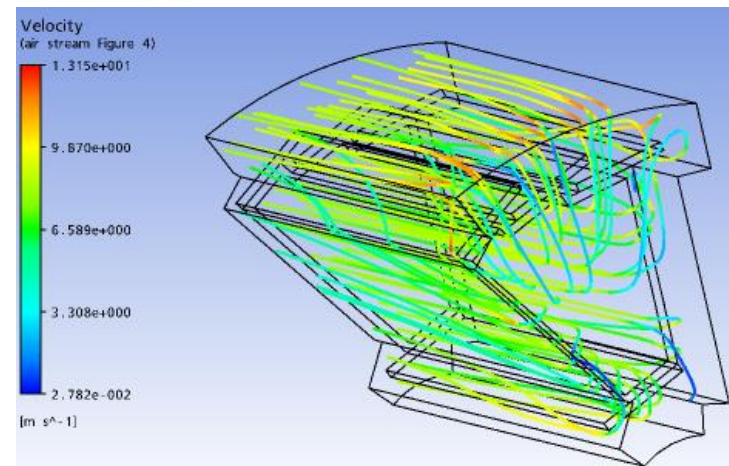
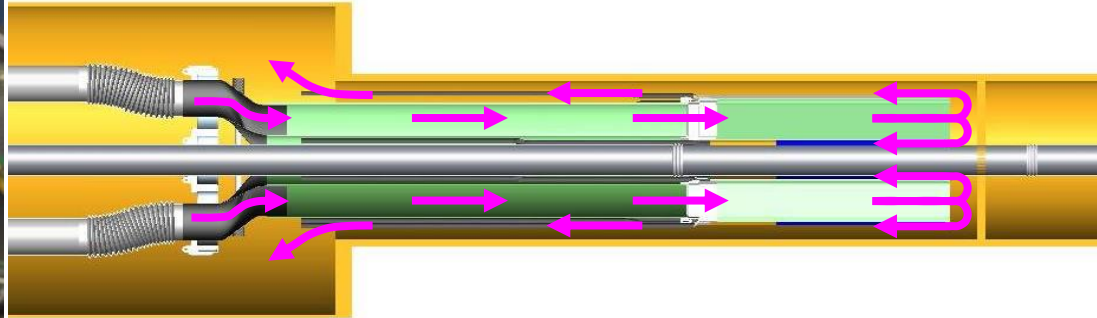

# Evaporative cooling

- Attractive because of large latent heat of evaporation & high heat transfer coefficient to cooling tube wall

Fluid	$T_{\text{sat}}$ [°C]	$p_{\text{sat}}$ [bar <sub>a</sub> ]	Latent heat [kJ/kg]	Liquid properties			GWP
				Density [kg/m <sup>3</sup> ]	Dynamic viscosity [10 <sup>-6</sup> Pas]	Heat conductivity [10 <sup>-3</sup> W/Km]	
C <sub>2</sub> F <sub>6</sub>	-25	8.97	87.4	1329.0	169.8	54.8	12000
C <sub>3</sub> F <sub>8</sub>	-25	1.68	100.7	1564.3	360.0	58.6	9000
C <sub>4</sub> F <sub>10</sub>	15	1.92	91.0	1533.6	244.8	44.4	6000
CO <sub>2</sub>	-25	16.83	293.3	1054.2	151.3	140.7	1
N <sub>2</sub> O	-25	15.44	285.8	1018.3	121.9	132.2	265
N <sub>2</sub>	-180	4.68	174.9	728.4	93.1	113.6	1

- T does not directly depend on the absorbed heat, but is given by saturation temperature corresponding to the local pressure in the pipe
  - As p drops along circuit, T decreases
- Usually evaporation temperature controlled by a base pressure at an external location in the fluid return (dome-loaded pressure regulator, accumulator, etc.) with offset due to on-detector and return line pressure drops
- It is mandatory for such systems that on-detector and return lines are carefully designed and prototyped
- Evaporative cooling fails, when too much of the liquid has evaporated ('dry-out')
  - Typically, this happens before the liquid has evaporated completely, but when the liquid film dissociates from the tube wall, and the remaining liquid becomes, as droplets, part of the vapour flow. At that point the HTC to from the coolant to the wall drops significantly. For CO<sub>2</sub> this can happen at 50% liquid

# p-h Diagrams

- To understand evaporative cooling circuits we often use p-h diagrams
  - Flow in thermally insulated pipe is isenthalpic (Joule-Kelvin expansion) and has only pressure drop
  - Heat in/out-flow changes enthalpy

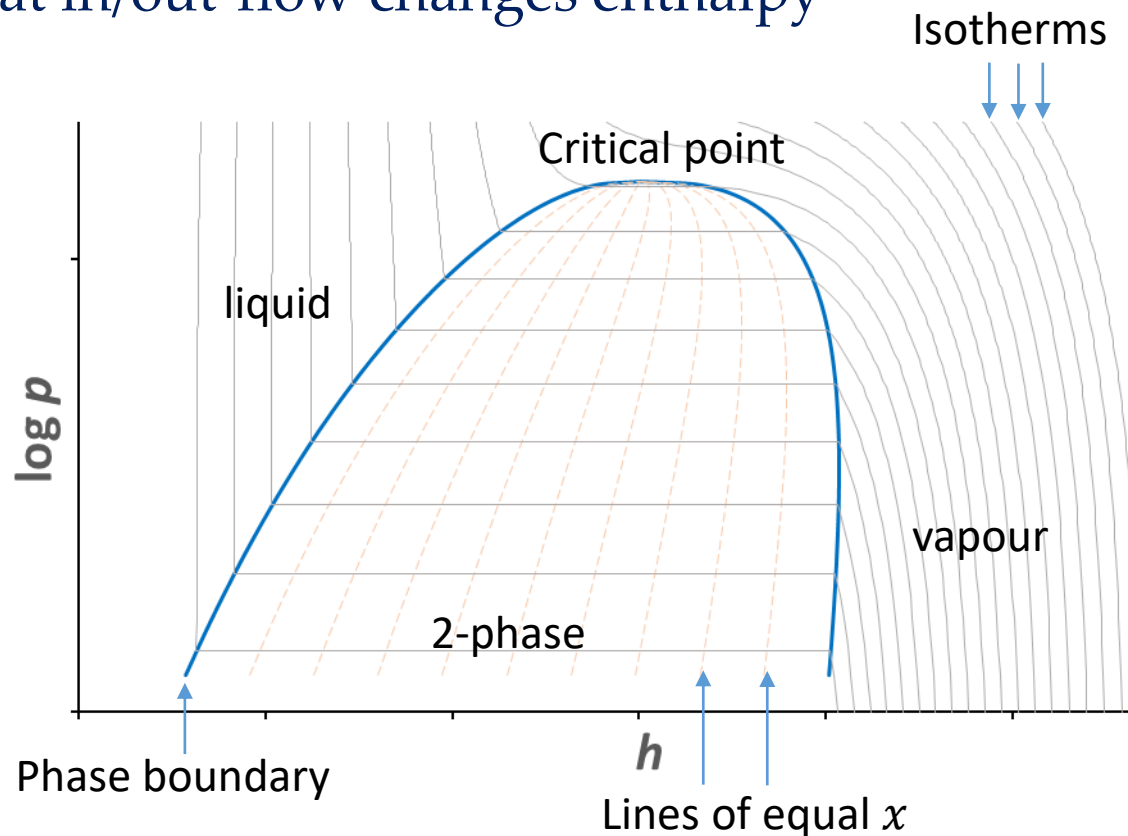

- An important parameter: Vapour quality:  $x = \frac{m_{vap}}{m}$
- The difference in enthalpy between the liquid and vapour phase boundaries is the latent heat
  - Note that the latent heat decreases for higher pressure (temperature)
- The region above the critical point is called 'transcritical'
  - No separate phases
  - CO<sub>2</sub> has a low critical point (31°C, 78 bar<sub>a</sub>)

# Fluid transport in evaporative systems

- How can we generate pressure head to move the fluid in evaporative system?
  - not shown: wicking (heat pipe)

Pump - driven

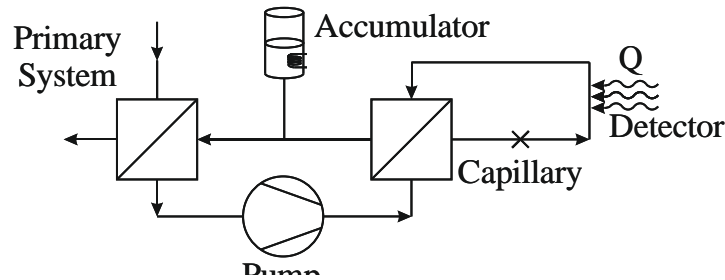

Compressor - driven

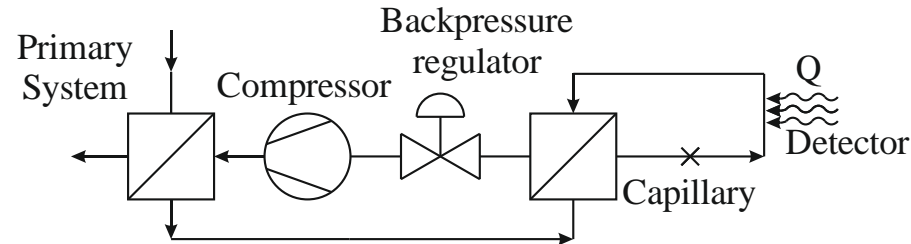

Gravity – driven  
(Thermosiphon)

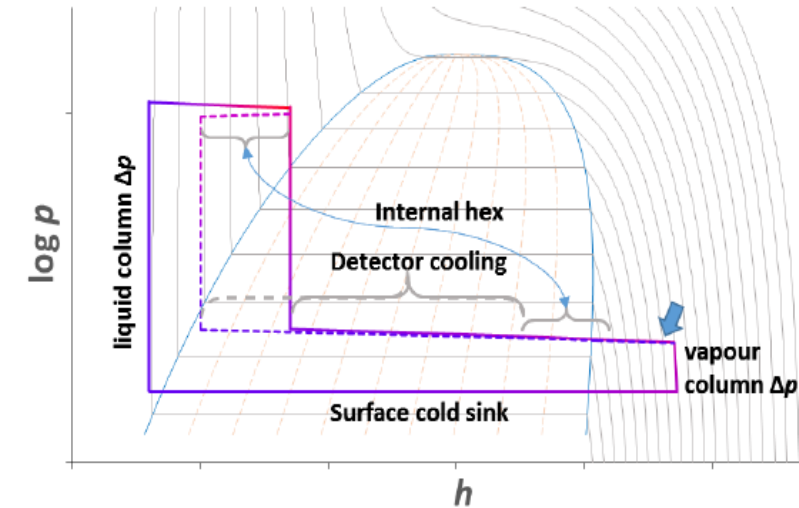
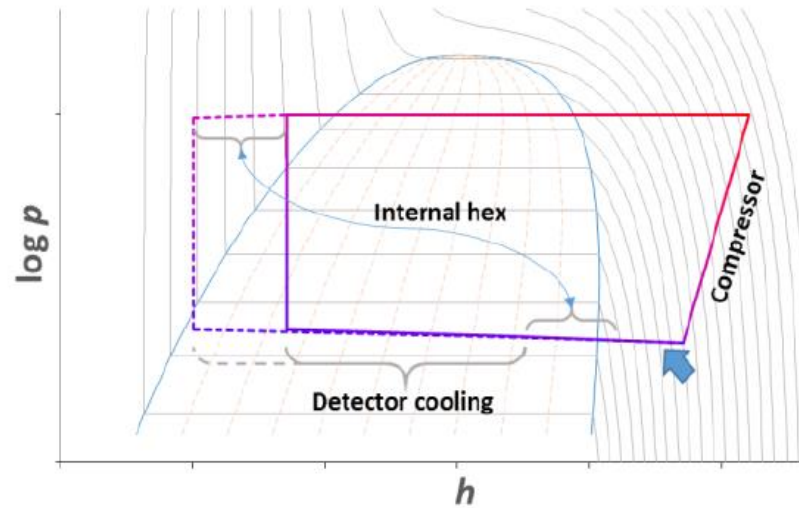
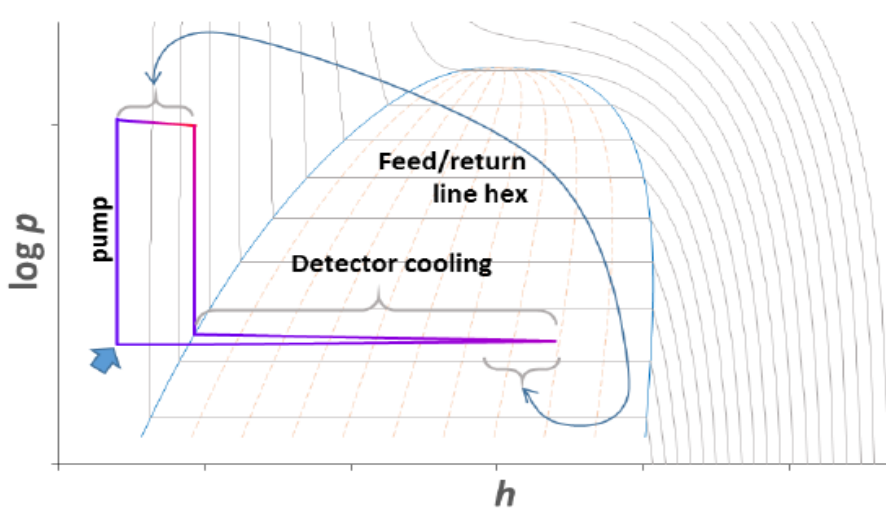
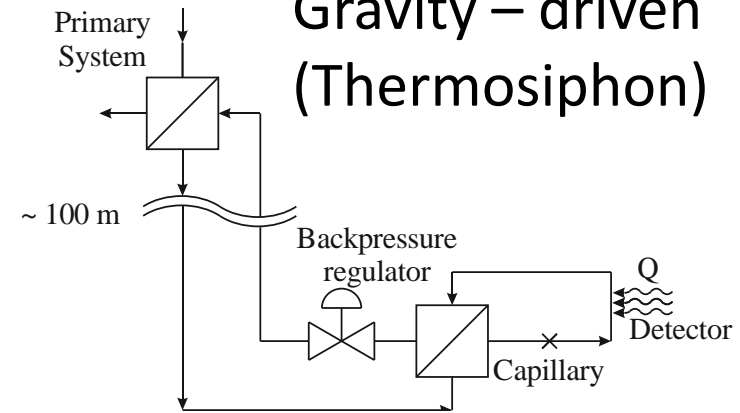

# 2-PACL

- 2-Phase Accumulator Controlled Loop has become the standard approach for CO<sub>2</sub> cooling systems (Bart Verlaet)
  - AMS (150 W @ 0°C) → LHCb VELO (1.5 kW @ -30°C) → ATLAS IBL (1.5 kW @ -40°C) → CMS pixel (15 kW @ -20°C) → CMS and ATLAS upgrades (few 100 kW @ -40°C)
- Evaporation pressure is controlled by pressure in an accumulator (fluid reservoir) in the plant
  - The pressure in the accumulator is controlled by changing its T
- Heat is rejected in a HEX to a primary cooling system
  - This has to be colder than any part of the detector cooling system
- The challenge is to guarantee liquid in the pump (no cavitation)
  - Low-shear pumps (membrane pumps)
  - Primary HEX must sub-cool the liquid before the pump
- This limits the evaporation temperature in the system, as CO<sub>2</sub> freezes at about -55°C
  - $p_{evap} = p(T_{HEX}) + \Delta p_{subcool} + \Delta p_{return}$
- Thermal contact between feed and return lines (typically in a concentric transfer pipe) guarantees saturation at the start of the evaporation channel

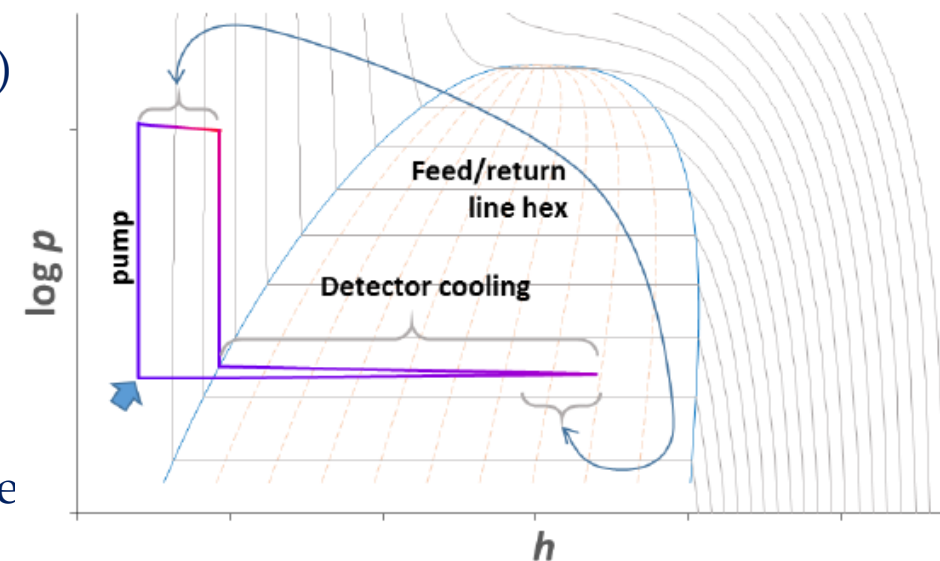
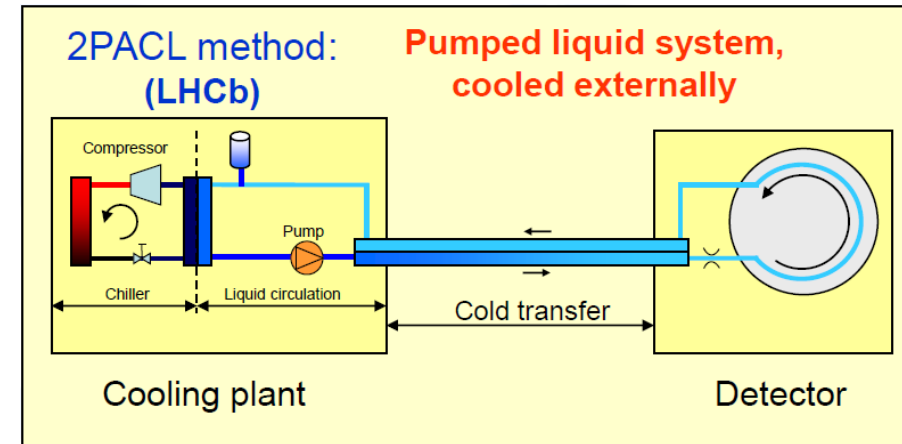

# Blow-off systems

- If you have a supply of high-p fluid (aka gas bottle) then one can use this to feed an open cooling system
- This makes sense for CO<sub>2</sub> as it is cheap and its loss is of no environmental concern
- Cannot vent directly to atmosphere (would freeze), but fluid first needs to be boiled off and warmed up, before release to atmosphere
  - Typically this is done in a water bath
- The challenge is that the bottle pressure is usually fixed, and the only means of control is the back pressure
  - This correlates flow and evaporation temperature
  - To control separately need a parallel by-pass (with heat load)

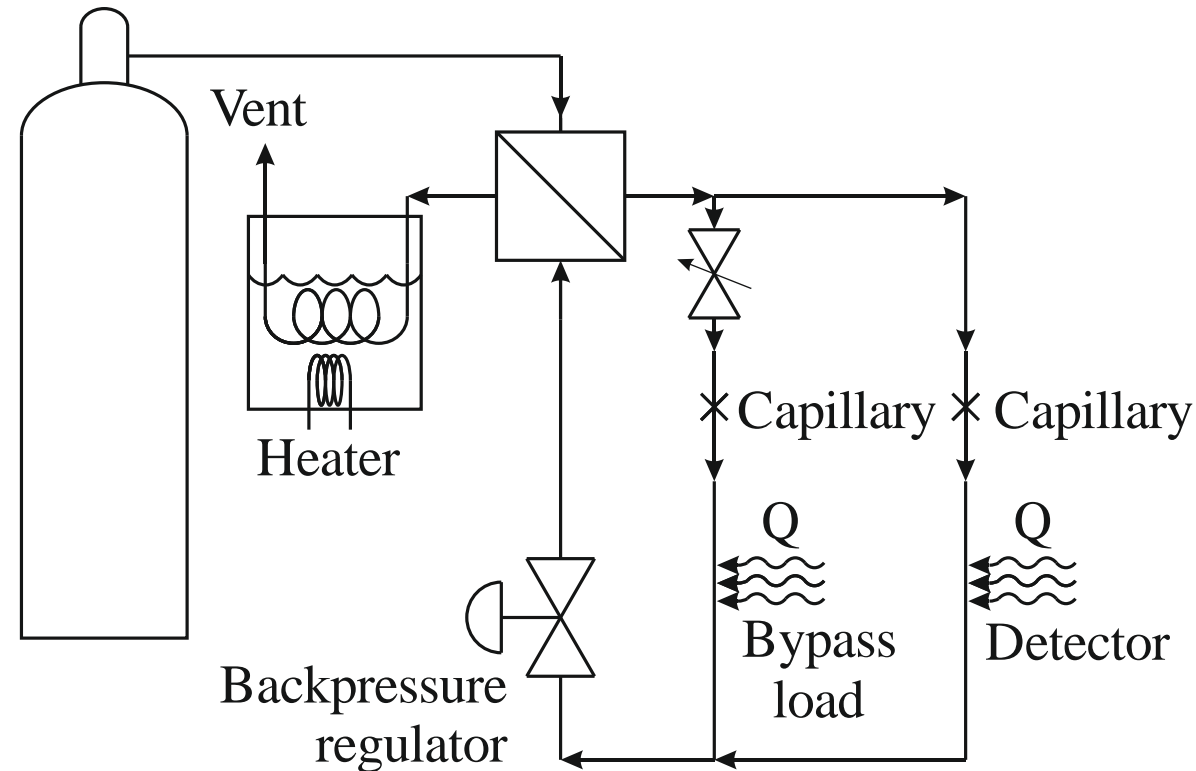

# What do we need capillaries for?

- Capillaries are flow restrictions
  - Typically a pipe with small diameter (order mm and smaller), but can be orifice, porous plug, etc.
- The biggest pressure drop in the circuit is in the capillary – why do we need it?
  1. The capillary defines the point where boiling starts – ideally right behind the capillary
  2. In systems with several parallel evaporators we need to balance the flow in the parallel branches for all cases of load variations
    - Load variations result in changes of the flow resistance in the pipes associated with the detector load and the return (detector load reduction will reduce impedance)
    - To always guarantee enough mass flow in all branches need to supply excess mass flow
    - The excess mass flow can be reduced by adding series impedance in each branch – this is the capillary
    - Typical impedance ratio  $R_c/R_d$  between 5 and 10

Illustration:

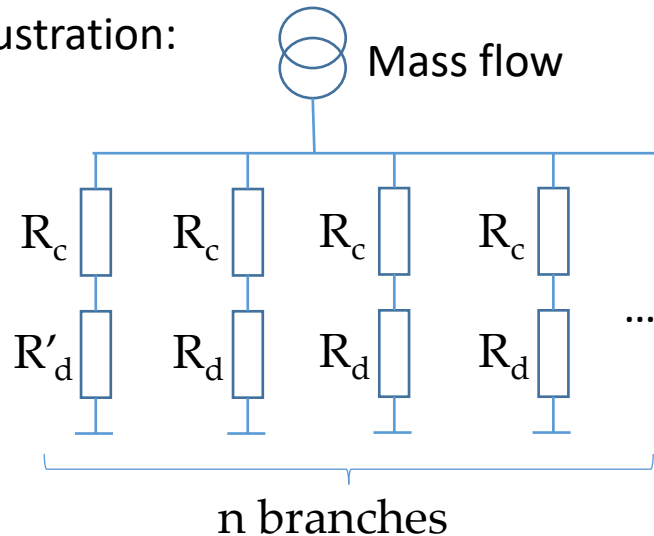

$$\frac{mf'}{mf} = \frac{1}{n} \left( (n-1) + \frac{R_c/R_d + 1}{R_c/R_d + R'_d/R_d} \right)$$

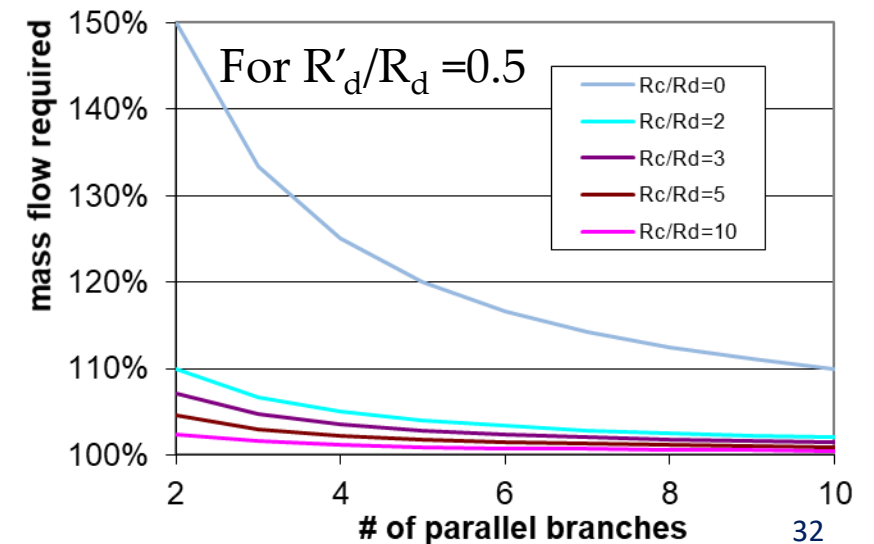

# Flow regimes

- Flow patterns do change along the pipe
  - Affect pressure drop and HTC
- Important is that liquid adheres to the wall
  - best HTC for annular flow
    - Good heat conductivity from wall to liquid & liquid evaporates at inner boundary to vapour core
- Once the liquid separates from wall (mist flow), the HTC drops significantly, and the system goes into dry-out

FLUDY 2.2, 02.05.2022, 12:31:37

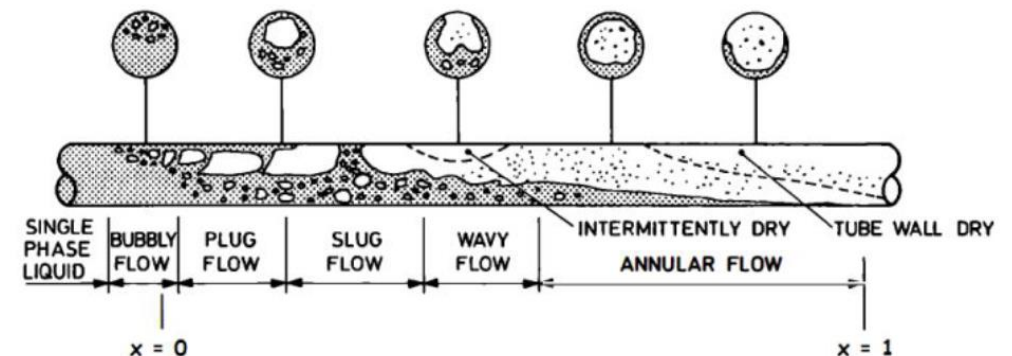
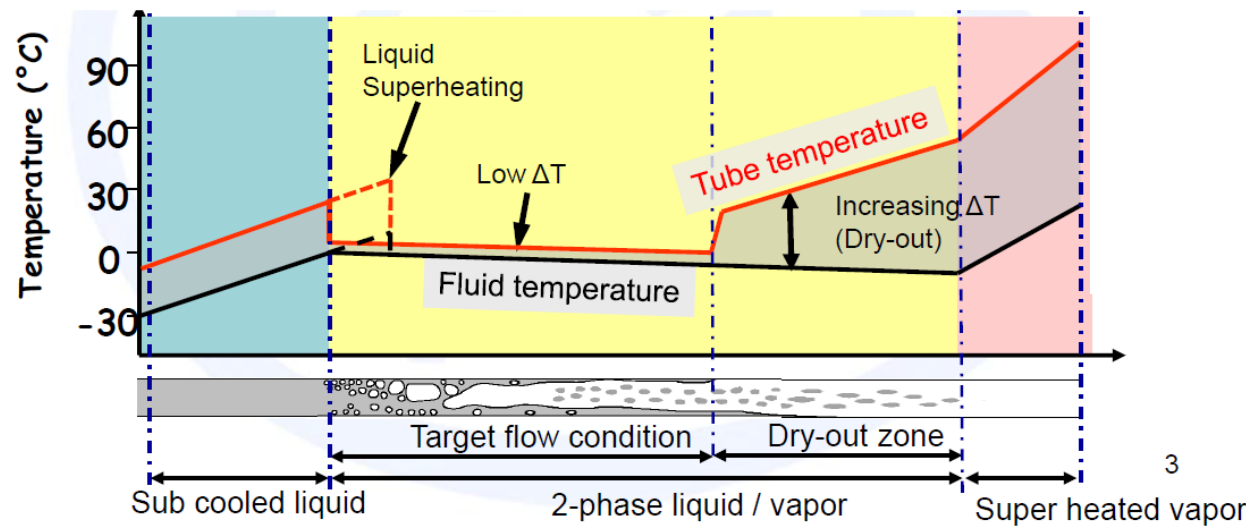
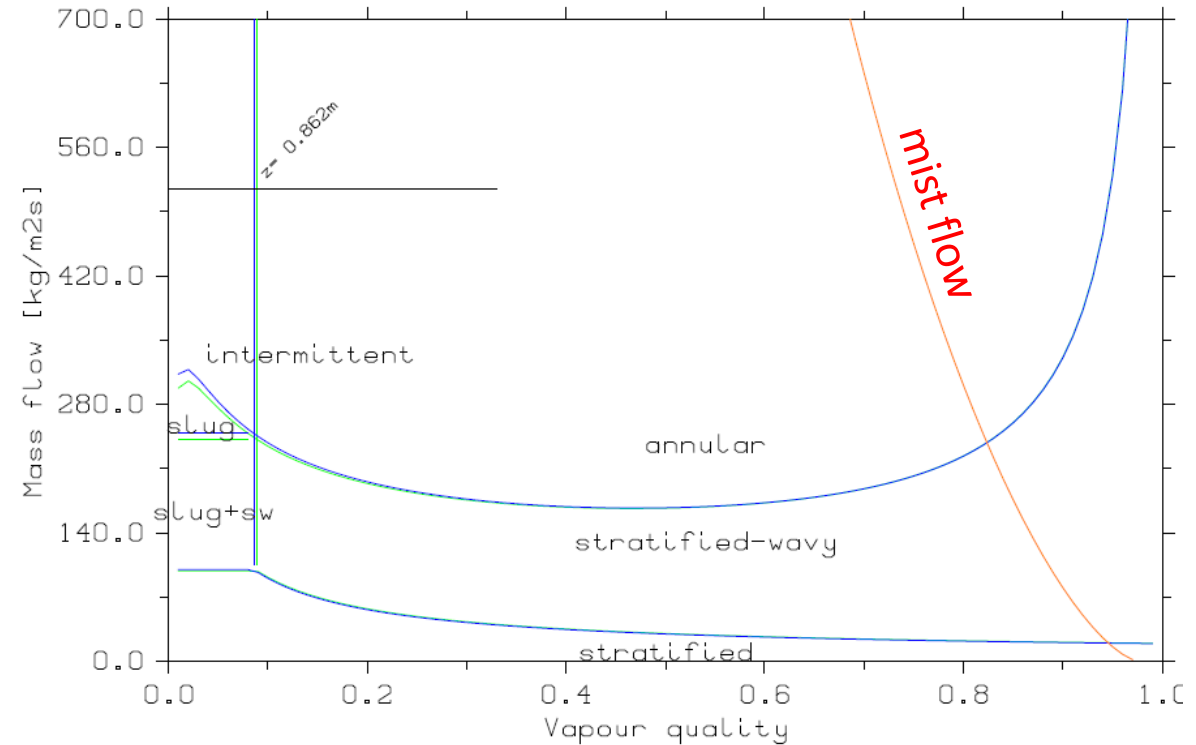

# Predicting evaporative cooling performance

---

- We have seen the importance of pressure drop and heat transfer coefficient for the performance of an evaporative cooling system
- In the design phase we would like to calculate these properties to optimize designs
- A large number of semi-empirical correlations exist to calculate these parameters for a given state, none of them works 100% (see for example D. Hellenschmidt CERN-THESIS-2020-245)
  - This is also because we occupy, as usual, an odd corner of phase space for fluid dynamics specialists
  - These correlations are usually 1D, but interestingly 3D CFD is not better (because boundary conditions at interfaces are complicated)
- Two programmes have been written, which take these correlations and calculate the performance of a complete loop
  - CoBra (by Bart Verlaat and the CERN cooling group)
  - FluDy (by me)
- Important: All these predictive methods are only good as guidance for the design, but results can be significantly (factor of 2) off
  - Always need to verify designs with actual prototype measurements (including all transfer pipes)

# Evaporative cooling – what can go wrong?

---

- When the system does not provide enough cooling power it will lead to dryout, the HTC at this location will drop and the outside temperature will increase
  - Interlocks need to be at the place where things start to go wrong, i.e. at the end of the evaporator
- On a more long-term timescale, we need to increase mass flow, this will increase evaporator & return line pressure drops
- If we get evaporator & return line pressure drops wrong then we will not achieve the target evaporation on the detector
  - This happened for the ATLAS ID, in the SCT we can't reach the design evaporation temperature of  $-25^{\circ}\text{C}$  (ok, because of lots of safety factors)
  - The only thing which protects you from that is accurate prototyping of complete system (incl. transfer lines), there is no way to retroactively fix this by changing the plant, you need to change the pipes, which is usually impossible
    - (there is one way out (if you are lucky): change your coolant...)
- Capillaries are notoriously difficult to dimension, small ID variation can have large effects – capillaries need to be tuned
  - If we get these wrong, then mass flows are off, and we can have issues with boiling starting at the wrong position
- Finally, a high-power cooling system is a very serious piece of engineering
  - You must do things properly, there are no short-cuts, or magic pieces of equipment
  - Make sure you are using established, proven technologies

# Educational excursion: Transport and linear networks

- You will have noticed that I have been using linear networks for three different situations
  - You will hopefully also agree with me that these are very useful
- Why do the same models and equations show up all over the place?
- Because the underlying physics concepts are the same
  - These are all transport phenomena:  $\vec{j} = -\kappa \vec{\nabla} \phi$

Current $j$	Conductivity $\kappa$	Potential $\phi$
Heat flux	Heat conductivity	Temperature
Electric current density	Conductivity	Potential/Voltage
Coolant flow	Pipe conductivity	Pressure
... and many more combinations		

- We can use similar continuity equations  $\vec{\nabla} \cdot \vec{j} = -\frac{d\rho}{dt}$
- And if we restrict the 3D equations to a limited number of fixed paths we can describe the behavior with linear networks with all the goodies (Ohm's law, Kirchhoff's laws, Thevenin equivalents, etc.)
- That's the beauty of physics

# Summary

---

- Heat is hard to move
  - Heat transfer by conduction cannot be avoided
    - Reduce length of thermal path
  - The most powerful heat transfer is forced convection, and here the most efficient is evaporative cooling
  - Evaporative cooling is not simple – challenges are how to get the coolant around, into all parallel branches, and predict the performance, which must always be checked with prototypes
- Know your thermal physics!