

Process fabrication III

E. Giulio Villani

Overview

- **Semiconductor fabrication process IIII**
 - Resist development
 - Etching
 - Implantation
 - Metallization

Semiconductor fabrication process

- The fabrication of semiconductor devices is a rather complex process
- Many intermediate steps and manufacturing precision at atomic level
- It starts with the growth of high purity Si crystals

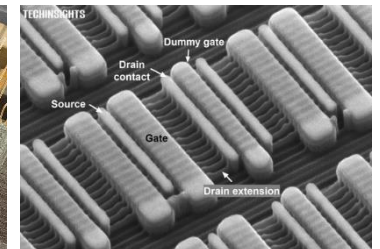
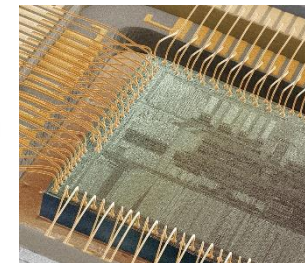
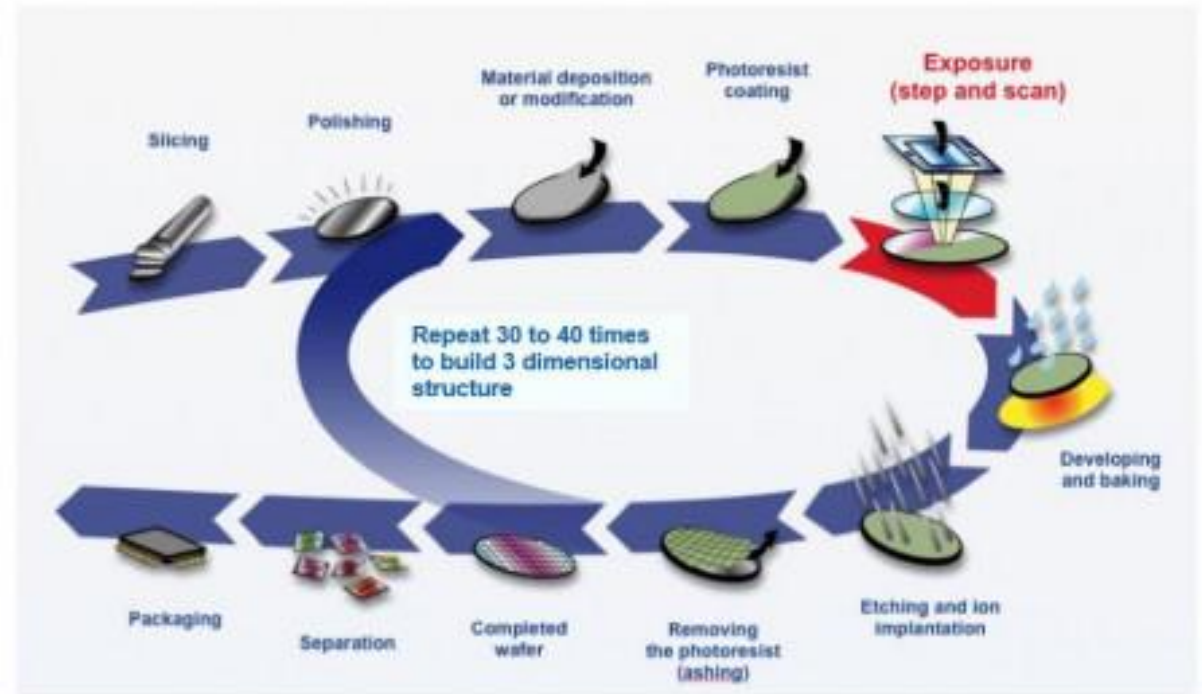

Resist development

- After photoresist deposition the mask is aligned and the process of exposure takes place
- The lithography process is what leads the development. Currently standard photolithography uses Deep Ultraviolet (DUV) light $\lambda = 193 \text{ nm}$ ArF excimer Laser. Shorter wavelengths (13.5 nm) are already used by few manufacturers.
- After the UV exposure, a post-bake to stabilize the film is performed, before the development

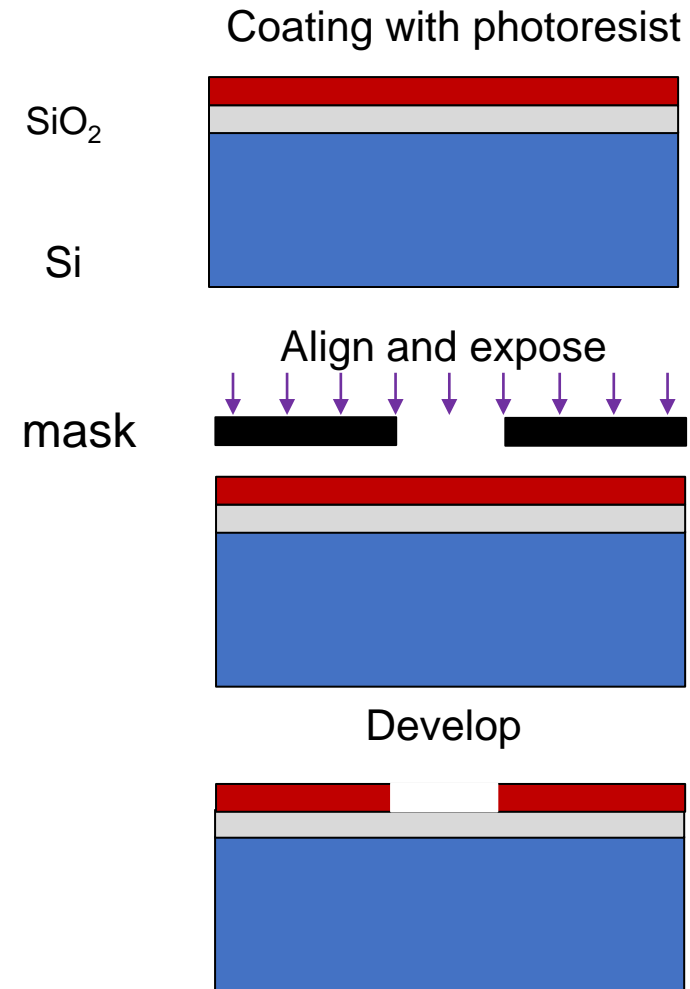

Resist development

- A developer is poured/sprayed onto a slowly spinning wafer
- For **positive** tone resist the developer removes the UV exposed parts
- For **negative** tone resist the developer removes the unexposed parts
- For more info: <https://www.microchemicals.com/>

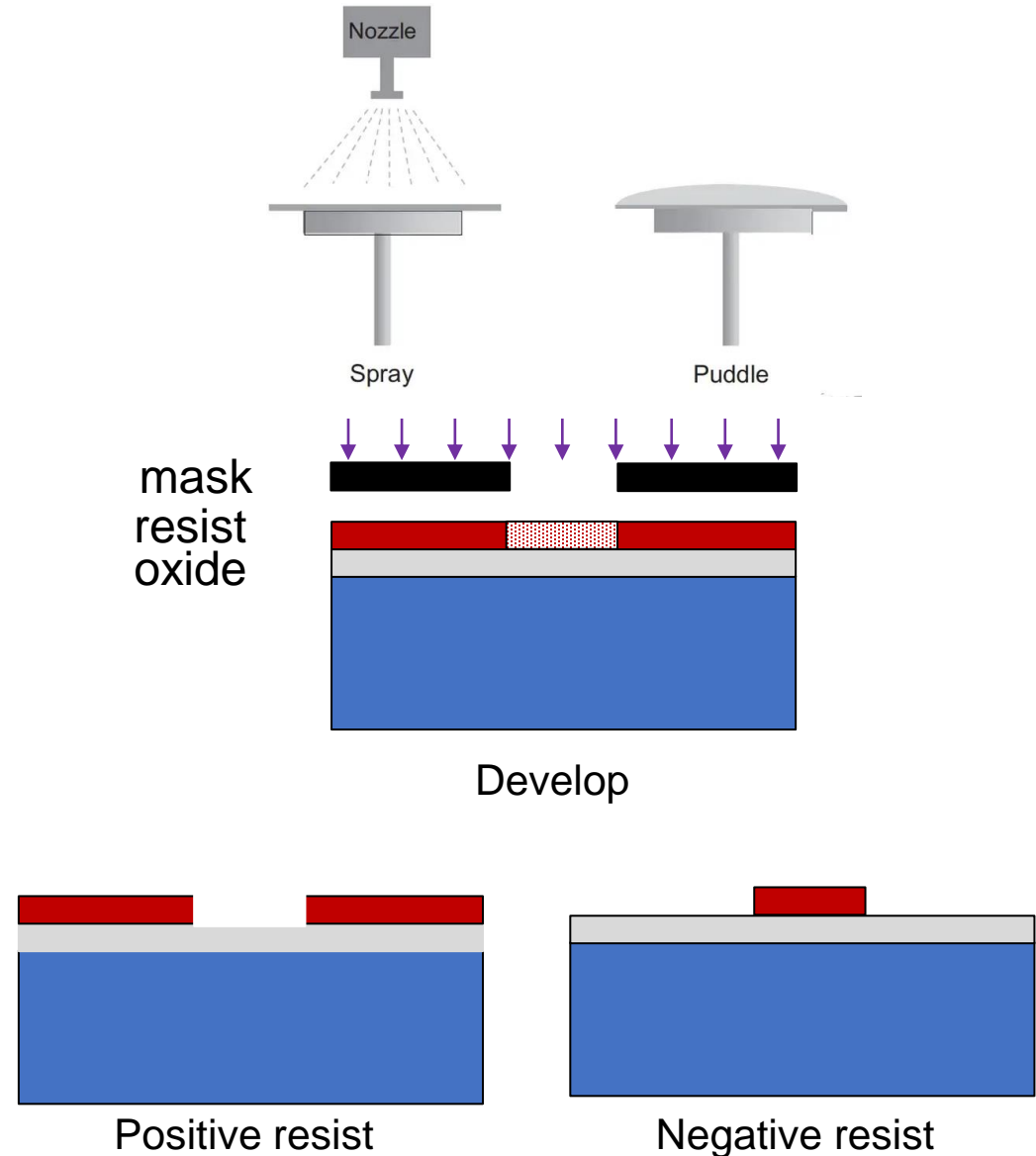

Etching

- After lithography, the process of etching usually follows
- Its purpose is to transfer a pattern onto the wafer, by removing material from some areas
- Either 'wet' or 'dry' etching is used
- **Selectivity:** etch rate ratio, e.g. $s = \text{etch}_{\text{SiO}_2} / \text{etch}_{\text{res}}$ ($\geq 4-5$)
- **Anisotropy:** $A = 1 - e_h / e_v$
- Also high etch rates is required, 1 – 10 nm/s

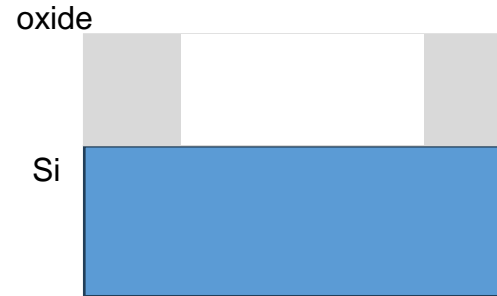

Good selectivity: only the material to be etched is removed

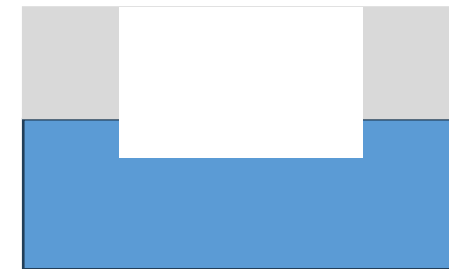

Poor selectivity: the material to be etched and the material below are etched

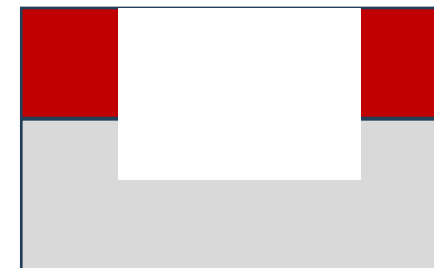

Good anisotropy: vertical sidewalls

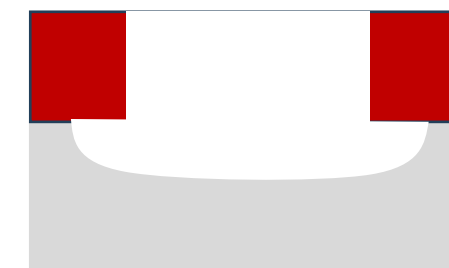

Poor anisotropy: round sidewalls

Etching

- Wet etching uses chemistry and might provide very high selectivity
- Plasma etching also uses reactive free radicals that chemically reacts with the material
- Usually poor anisotropy $A = 1 - e_h/e_v$
- Cheap and good selectivity but not suitable for precision etching, i.e. nanostructures

Wet etching example: Buffered HF etching of SiO_2

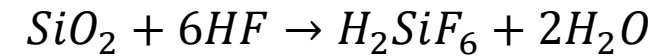

F displaces O atoms and dissolves oxide, no effect on Si: very high selectivity

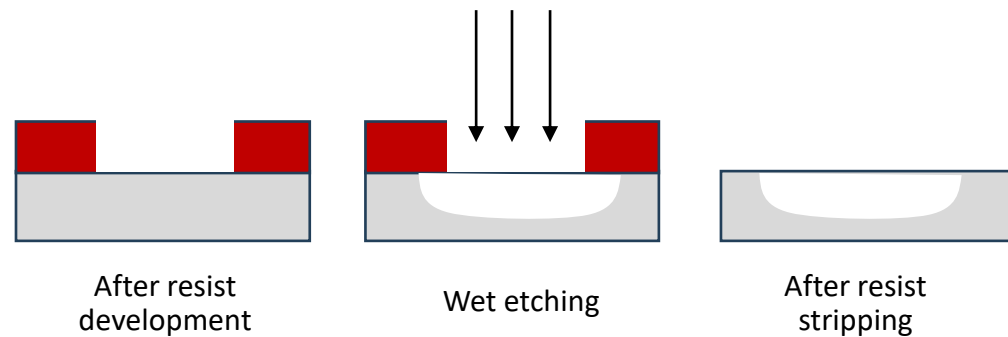

Etching

- Sputter etching is a purely 'physical' process, i.e. no chemical reaction involved
- Anisotropy very high but poor selectivity
- The wafer is bombarded with chemically inert ions e.g. Ar^+
- Possible damage to the crystal (similar to ion implantation)

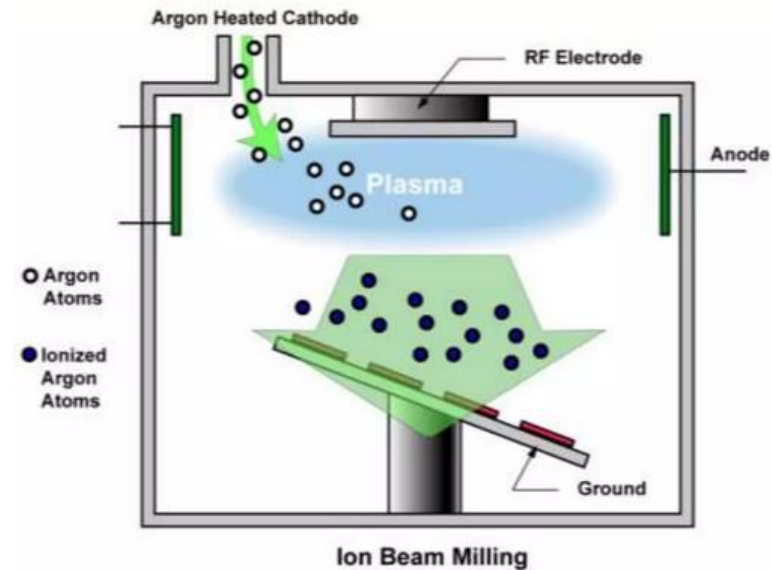

Plasma generates ion beam (Ar^+) which are extracted and accelerated towards the sample
The ions sputter off atoms of the target
Low pressure ($1\text{e-}4$ Torr) to increase mean free path and provide line of sight travel to increase anisotropy

Etching

- Ideally one wants to combine **selectivity** using chemical reactions (like in wet etching) and **anisotropy** (like in sputter etching)
- Using Reactive Ion Etching (RIE) it is possible to achieve both high selectivity and anisotropy
- RIE uses ions bombardment to enhance the chemical process
- Chemical etching happens where the ions strike, leading to high selectivity and anisotropy

	High selectivity	Low selectivity
High anisotropy	Reactive Ion etch (RIE)	Sputter etch
Low anisotropy	Wet/plasma etch	

Etching

- Reactive-ion etching (RIE) uses chemistry and ions to simultaneously provide high selectivity and anisotropy
- The wafer is negatively biased
- Positive ions are accelerated towards its surface
- A plasma creates reactive species which diffuse towards the wafer
- The exposed parts of the wafer react and are etched
- Etch byproducts may deposit onto the surface and provide sidewall passivation as they do not react with the reactive species
- Unique RIE recipe for a specific etching process

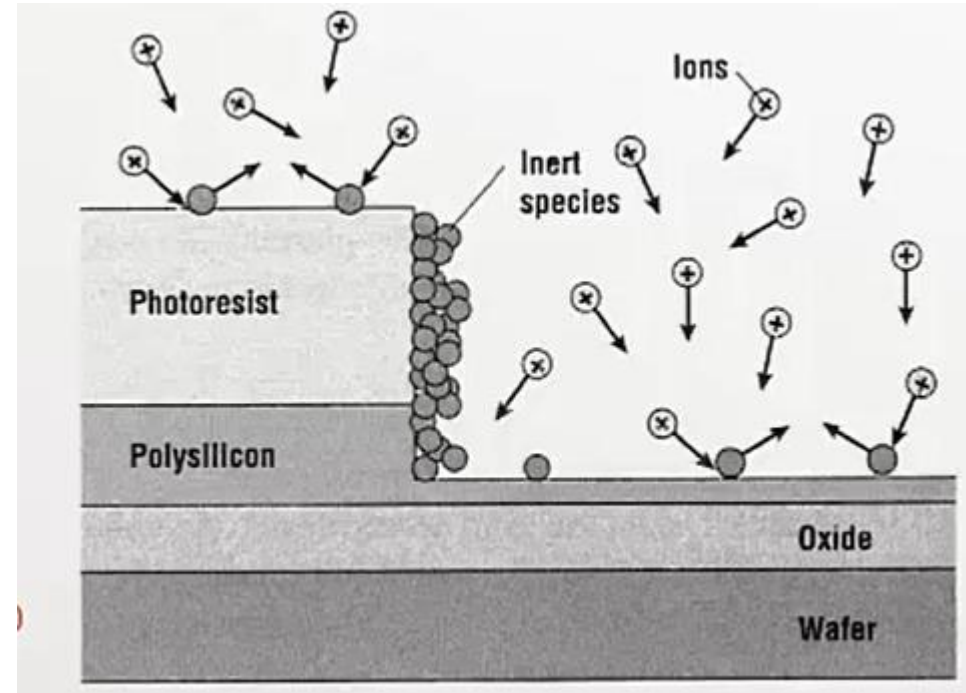

Polysilicon
 CF_4/O_2

SiO₂
 CF_4/H_2

Resist
 O_2

Etching

- Issues with RIE etching:
 - Ion damage to wafer
 - Etch loading (the etch rate changes depending on the mask pattern, i.e. Si with narrow trenches etch more slowly than wider ones)

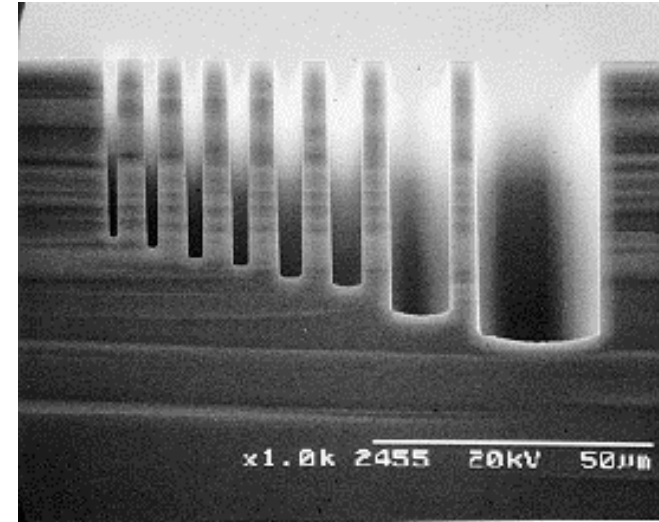

A wide trench allows fluorine radicals to reach the bottom more easily, hence fast etch rate compared to the narrow trench

Source: <https://www.samcointl.com/opto/>

Ion Implantation

- Technique to introduce atoms of dopants into a semiconductor material and create regions of different electrical characteristics
- Historically proposed by Shockley in 1949, became common in the 70's
- Ionized gas ions are accelerated by strong electric field and injected into a target wafer (a few nm to a few μm depth). Ion implanters spin-off from particle accelerator technology

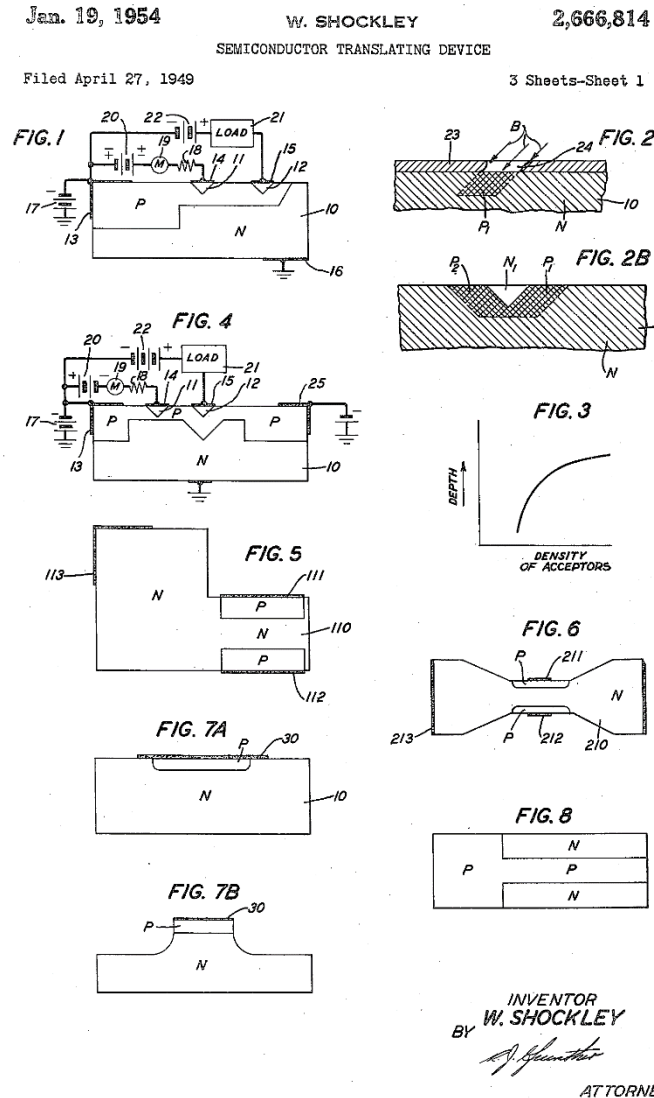

...the layer is formed by bombardment of one face of the N-type body with nuclear particles and the N-type zones in the layer are produced by masking the surface areas of the layer from the bombarding particles.

Ion Implantation

Pros

- Precise control of dose and depth profile, complex profiles
- RT process (can use photoresist as mask)
- Wide selection of masking materials e.g. photoresist, oxide, poly-Si, metal
- Excellent dose uniformity across wafers
- Little lateral dopant diffusion, important for small devices

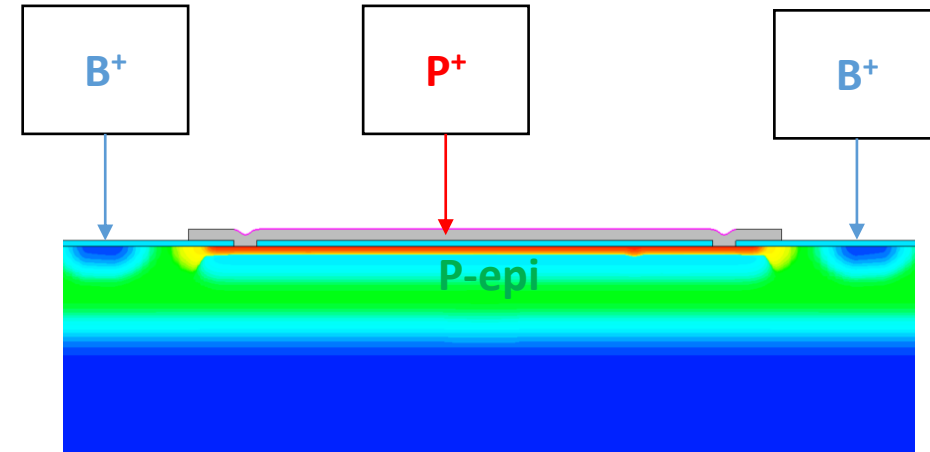

4 implantations process, 1 metal layer

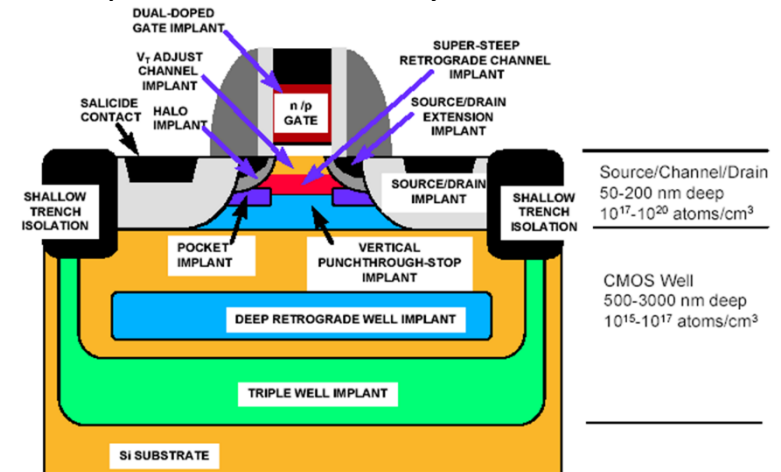

>10 implantations process

Ion Implantation

Cons

- Equipment big and expensive (> 1M\$)
- Radiation damage: reticle damage due to implantation not always possible to correct
- Difficult to obtain very shallow and very deep doping
- Masks material can be scattered into the wafer, creating impurities and defects

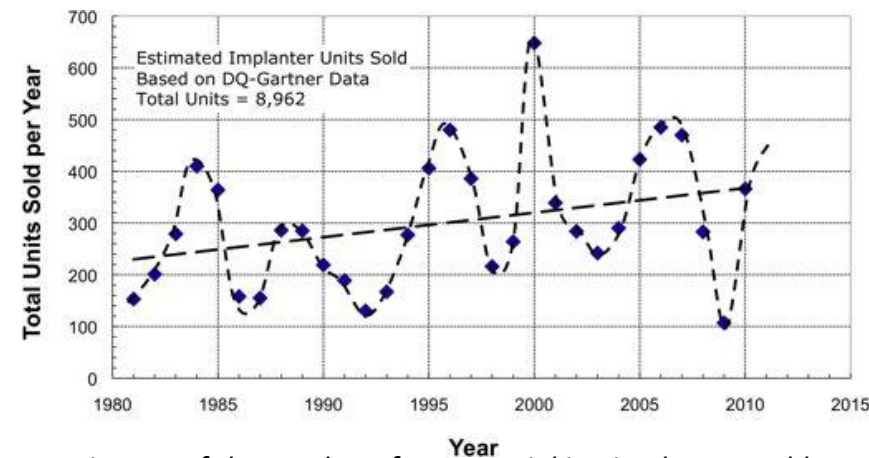

Estimates of the number of commercial ion implanters sold per year, mainly for IC fabrication, showing the '5 year cycle'

Ion Implantation

- Ions used: As, B, P, In, O, Ar
- Energy: 1 - ~1000's keV
- Flux: $10^{12} - 10^{14} \text{ cm}^{-2} \text{ s}^{-1}$
- Dose: $10^{11} - 10^{18} \text{ cm}^{-2}$
- Uniformity: $\pm 1\%$ across 12'' wafers
- Absolute dose accuracy: $\pm 10 - 15\%$
- Temperature: RT

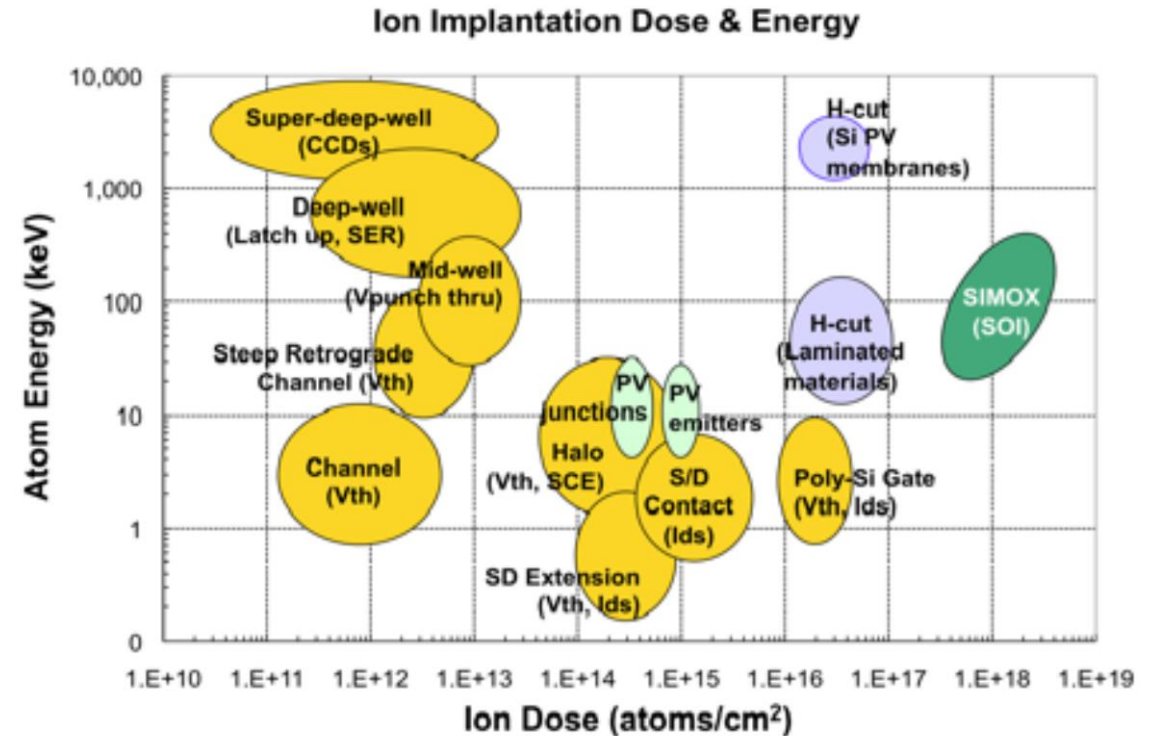

Dose and atom energy regions for CMOS transistor doping (gold), high dose hydrogen implants for Si layer splitting (lavender), and direct implantation of oxygen to form Silicon-on-Insulator (SOI) wafers (green).

Ion Implantation tools

Typical ion implanter for semiconductor process consists of several elements

1: Ion source

2: Analyzing Magnetic

3: Ion Accelerator

4: Beam manipulating system

5: End station

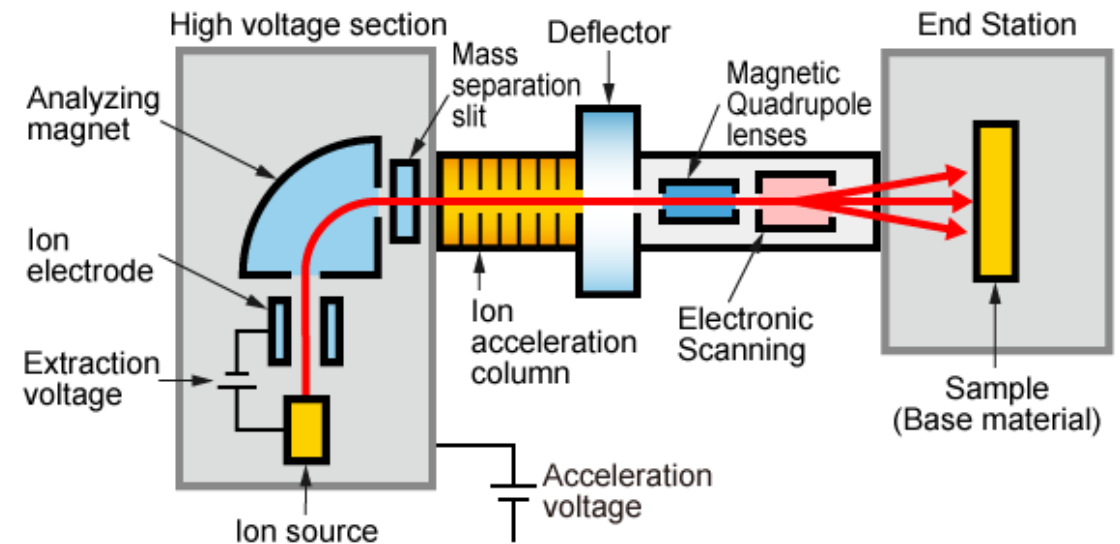

Ion Implantation tools

- **Ion source:**

- Filament emits thermionic electrons, accelerated to gain enough energy (20 – 30 kV)
- The electrons collide with the molecules or atoms (AsH_3 , PH_3 , BCl_3) and ionize them
- A negative bias to the end side of the chamber extracts the positive ions towards the magnetic analyzer

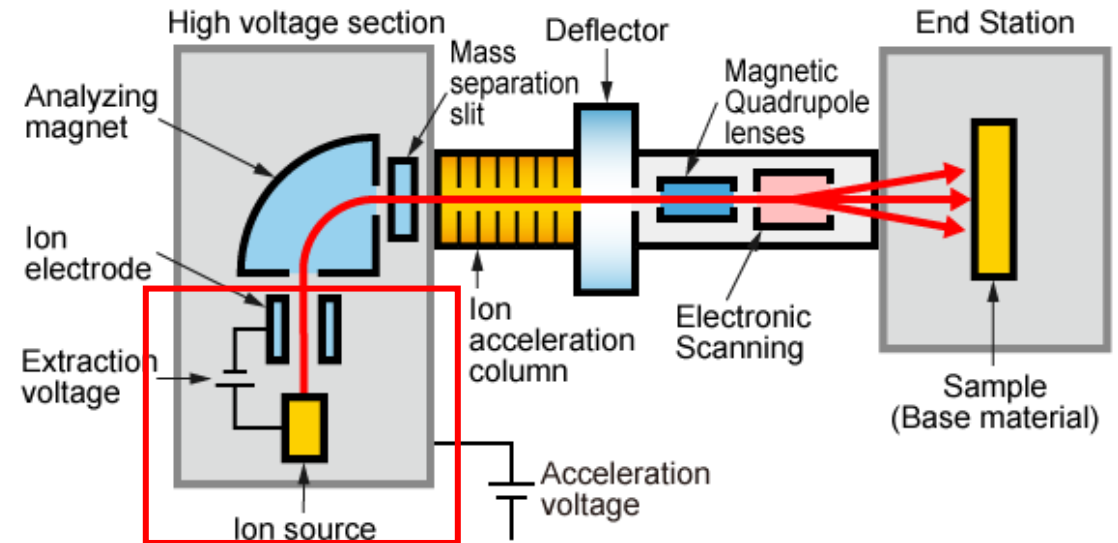

Ion Implantation tools

- **Magnetic analyzer**

- Plasma provides positive ions, $(B^{11})^+$, BF_2^+ , $(P^{31})^+$, $(P^{31})^{++}$
- The correct ions need to be separated to choose what to implant (e.g. acceptors B^{11} , or donors P^{31})
- A **magnetic mass analyzer** selects the desired species via a magnet ($< 1\text{ T}$) which bends the ion beam: only one mass with the correct radius of curvature goes through the slit ($\sim\text{mm's}$) and hits the wafer

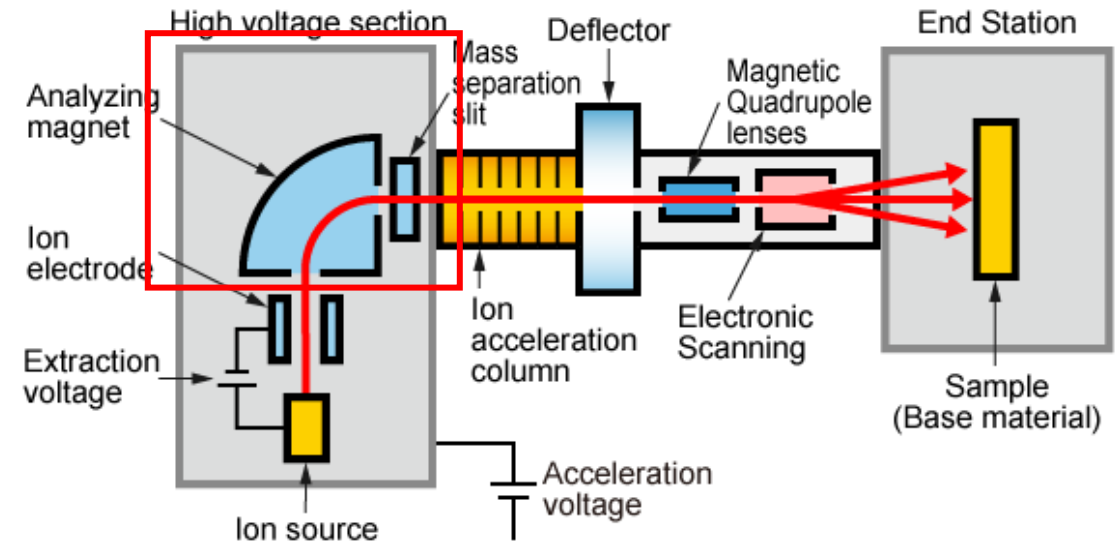

Ion Implantation tools

- **Accelerator**

- n-sections LINAC, giving a total $\times n$ acceleration at relatively low voltage: $E \sim 1000\text{'s keV}$, $I \sim \text{mA}$
- Single charge ion $\Rightarrow E = e * HV$
- n^+ charge ion $\Rightarrow E = n * e * HV$

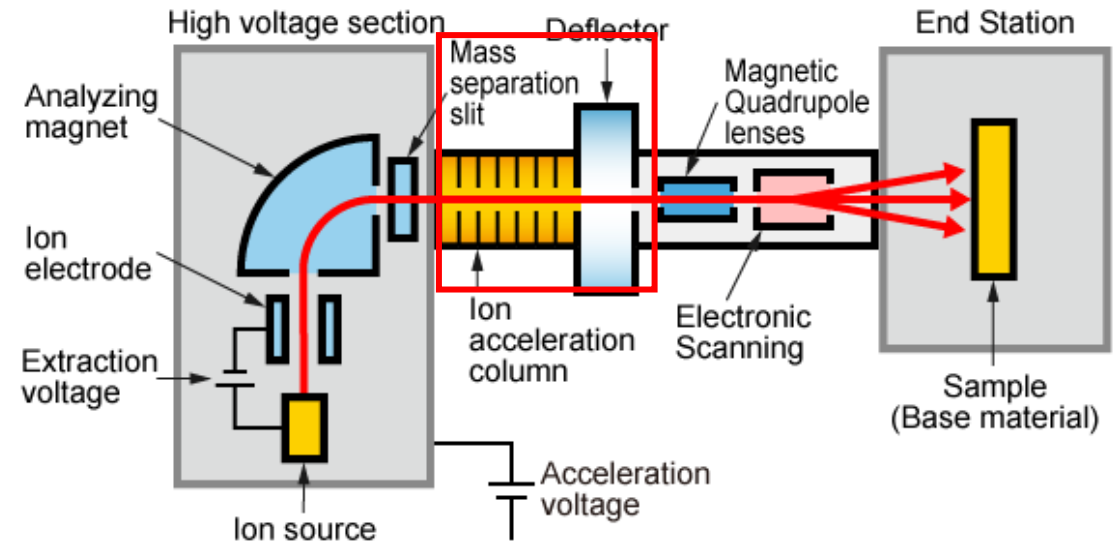

Ion Implantation tools

- **Beam manipulating system**
 - After acceleration the ion beam is focused (\sim few cm^2)
 - A small deflection via electrostatic means is applied to discard neutral components to a beam stop
 - The ion beam passes through an electrostatic deflection system and scanned over the wafer ($\sim \varnothing$ 30 cm)

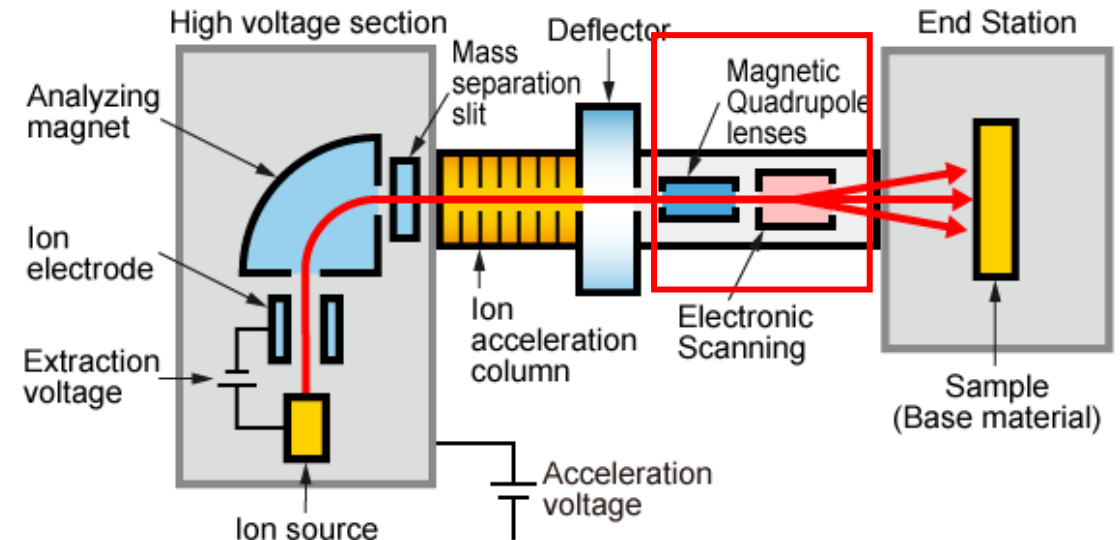

Ion Implantation tools

- **End station**

- Wafers mounted on rotating disc (15-25 wafers/disc) > 100 wafers/hr
- Dose measurement performed by integrating the ion current via a Faraday cup
- Complex design of the Faraday cup is needed for high current implanters

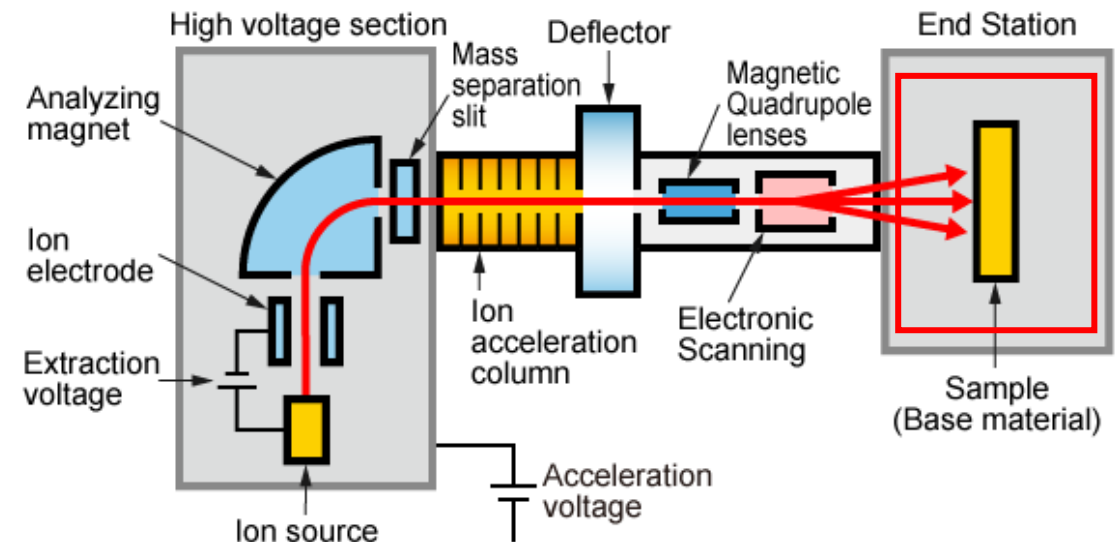

Ion Implantation doping profile

- **Adiabatic approximation** : Scattering of ions with target is described using two separate collision processes:
- S_n collisions with nuclei (energy loss and geometry of trajectory)
- S_e collisions with electrons (energy loss only).

$$S = \left(-\frac{dE}{dx} \right)_{nuclear} + \left(-\frac{dE}{dx} \right)_{electronic} = S_n + S_e$$

S_n screened potential classical two-body scattering
(Binary Collision Approximation BCA)

S_e interactions of ion with target electrons
(Lindhard's Bethe-Bloch)

Ion Implantation doping profile

- At **low energy**, nuclear collisions dominate: at the end of its range the ion has low energy, S_n dominates leading to more crystalline damage
- At **high energy**, electronic collisions dominate, from scattering of electrons \sim Ohm's law

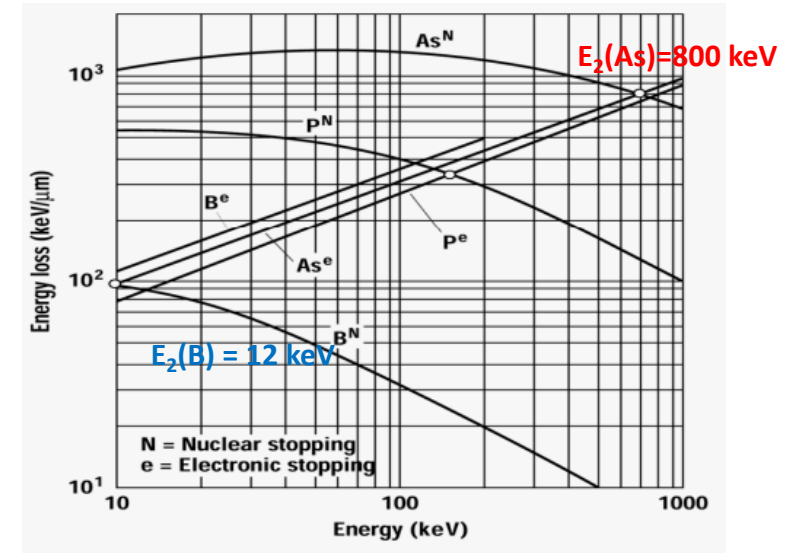
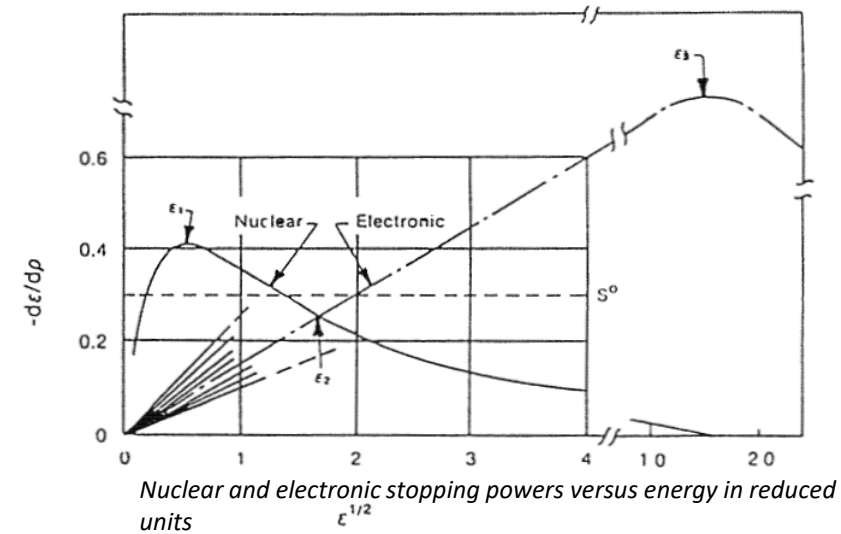

Ion Implantation doping profile

- From $\frac{dE}{dx}$, the total stopping power, one can estimate the average ion range

R: range

R_p : projected range along axes of incident ion, with straggle (σ) ΔR_p

R_s : perpendicular distance

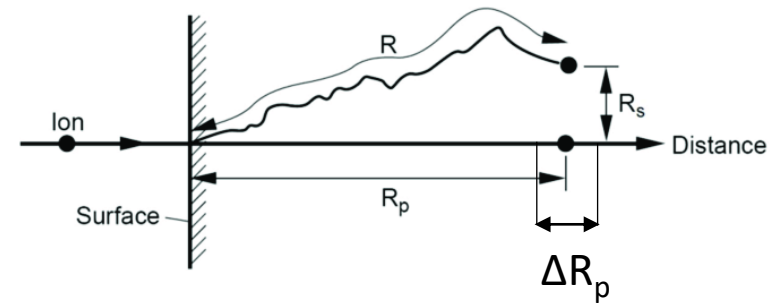

$$\frac{dE}{dx} = \left(\frac{dE}{dx}\right)_n + \left(\frac{dE}{dx}\right)_e$$

$$R = \int_0^E \frac{dE}{-\frac{dE}{dx}}$$

Ion Implantation doping profile

- Projected range R_p and Straggle ΔR_p for common dopants
- Transverse spread increases with R_p ($R_s \approx (1 + M_2/3M_1)R_p$)
- limiting factor on lower limit of mask opening, which affects maximum device density

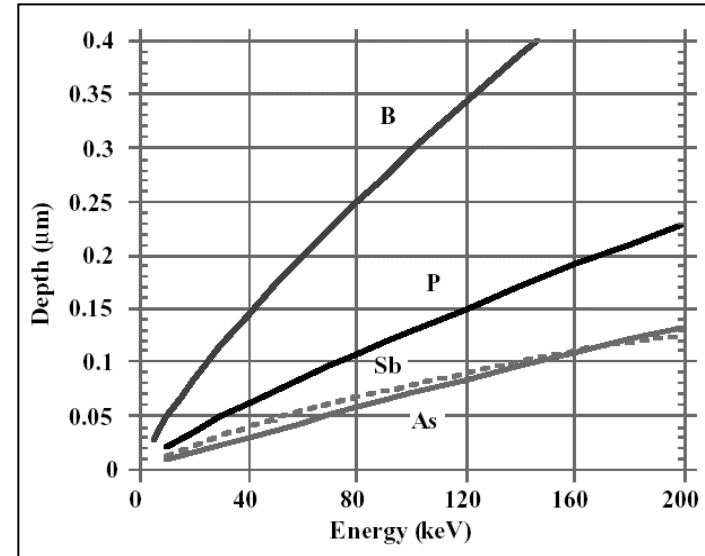

Projected range R_p

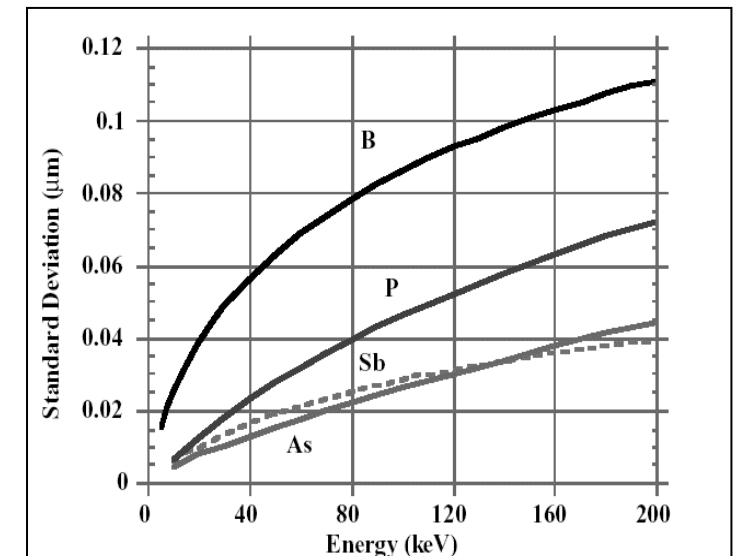

Straggle ΔR_p

Ion Implantation doping profile

- Example of MC (>5000 runs) ion range simulations (SRIM*) of B¹¹ and P³¹ implanted in amorphous Si
- No annealing, i.e. no dopants activation, no thermal diffusion

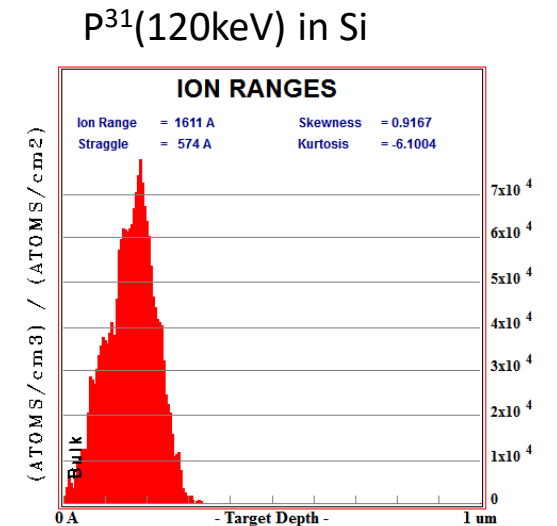
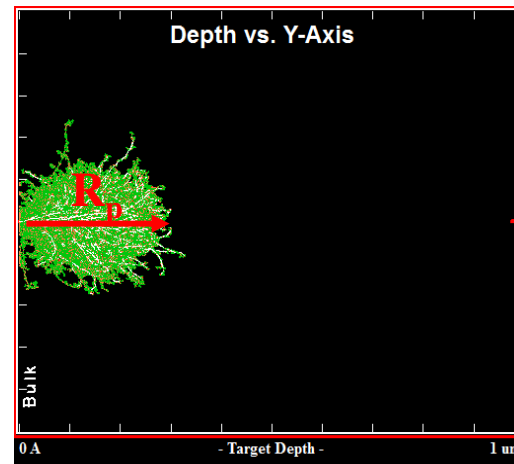
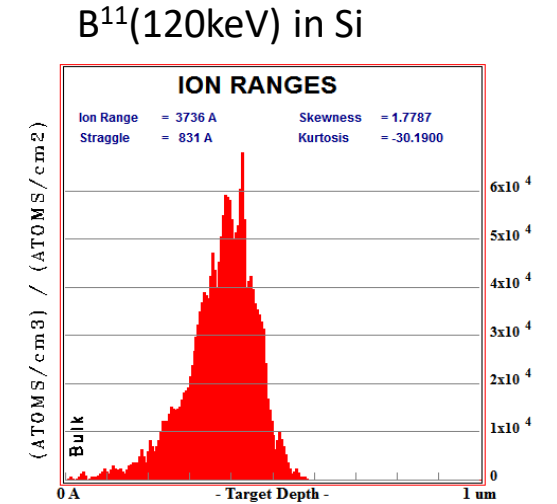
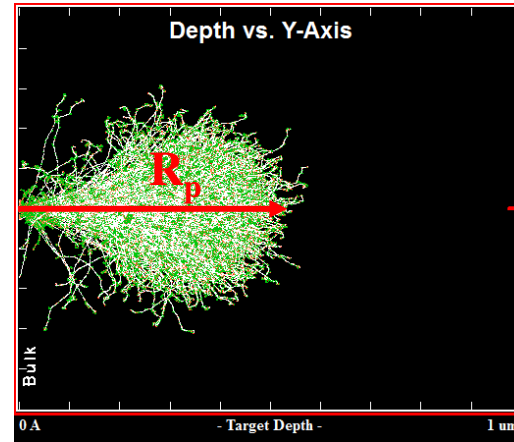

* <http://srim.org/>

Ion Implantation doping profile

- The range distribution of implanted impurities is described, as a first approximation, by a **symmetrical Gaussian distribution** (2 moments: R_p = projected range, ΔR_p = straggle)

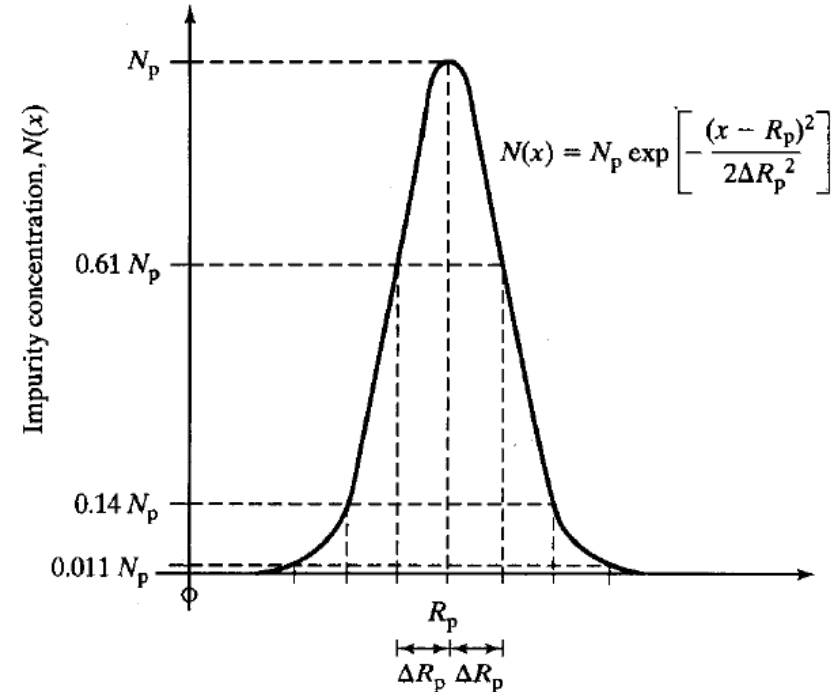

$$N(x) = N_{pk} e^{-\frac{(x-R_p)^2}{2(\Delta R_p)^2}} = \frac{Q}{\sqrt{2\pi}\Delta R_p} e^{-\frac{(x-R_p)^2}{2(\Delta R_p)^2}}$$

$$Dose = \int_0^L N(x) = Q = \sqrt{2\pi}\Delta R_p N_{pk} [atoms \cdot cm^{-2}]$$

Ion Implantation doping profile

- Higher moments are needed to describe realistic profiles:
 - skewness** (γ), describing asymmetry of distribution
 - kurtosis** (β), describing peak sharpness of the profile

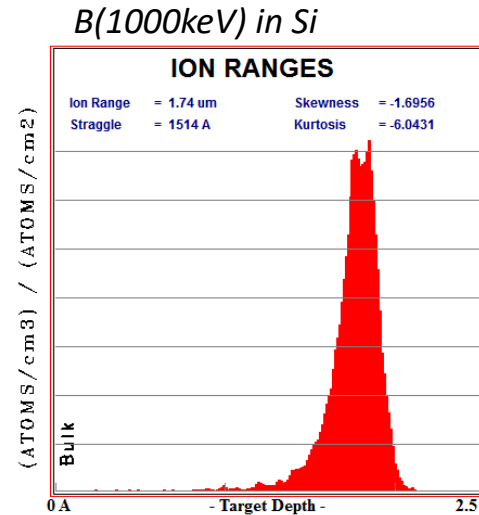

$$Q = m_0 = \int_{-\infty}^{+\infty} N(x) dx$$

$$R_p = m_1 = \int_{-\infty}^{+\infty} xN(x) dx$$

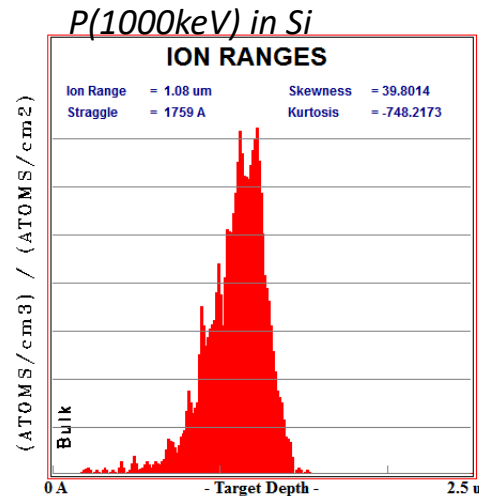

$$\Delta R_p = m_2 = \int_{-\infty}^{+\infty} (x - R_p)^2 N(x) dx$$

$$\gamma = m_3 = \frac{1}{\Delta R_p^3} \int_{-\infty}^{+\infty} (x - R_p)^3 N(x) dx$$

$$\beta = m_4 = \frac{1}{\Delta R_p^4} \int_{-\infty}^{+\infty} (x - R_p)^4 N(x) dx$$

Ion Implantation doping profile

- Analytical description of doping profiles can be obtained from Pearson distribution
- Coefficients of Pearson's equation are related to the four moments
- Explicit formula for the implanted profile can be obtained

$$\frac{df}{dx} = \frac{(x - a)f}{b_0 + b_1x + b_2x^2}$$

Pearson distribution function defined as DE solution

$$a = b_1 = -\frac{\gamma\Delta R_p^2(\beta + 3)}{10\beta - 12\gamma^2 - 18}$$

$$b_0 = -\frac{\Delta R_p^4(3\gamma^2 - 4\beta)}{10\beta - 12\gamma^2 - 18}$$

$$b_2 = -\frac{6 + 3\gamma^2 - 2\beta}{10\beta - 12\gamma^2 - 18}$$

$$C(x) = C_o \exp \left\{ \frac{1}{2b_2} \ln(b_2x^2 + b_1x + b_0) - \frac{2b_2a + b_1}{b_2\sqrt{4b_2b_0 - b_1^2}} \arctan \left(\frac{2b_2x + b_1}{\sqrt{4b_2b_0 - b_1^2}} \right) \right\}$$

Generic profile formula from Pearson distribution

A. F. Tasch et al., "An Improved Approach to Accurately Model Shallow B and BF₂ Implants in Silicon," Journal of the Electrochemical Society, vol. 136, no. 3, pp. 810–814, 1989,

Ion Implantation doping profile

- Analytical doping profiles description reasonably accurate for heavy ions
- Lighter ions more accurately described using MC (crystal orientation depending)

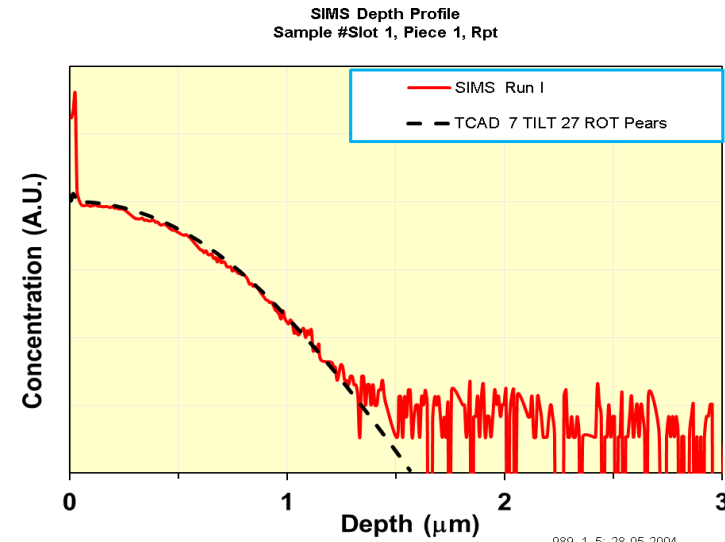

SIMS and Pearson IV distribution – 31P on $\langle 100 \rangle$ Si

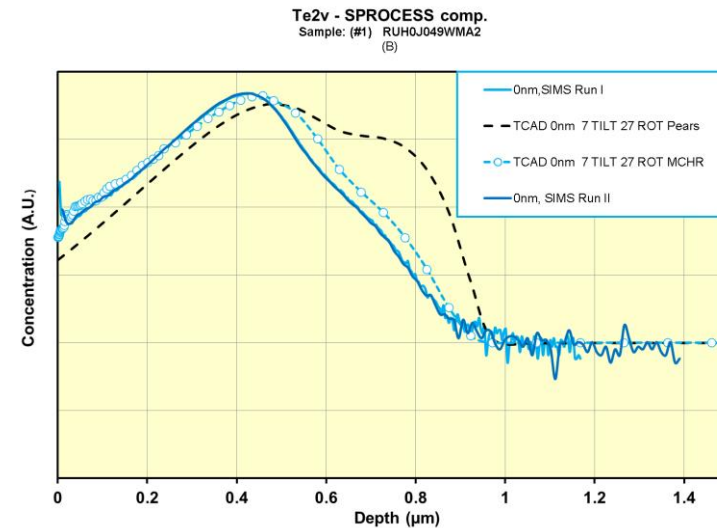

SIMS, Pearson IV distribution and MC run – 11B on $\langle 100 \rangle$ Si

Ion Implantation masking

- Purpose of the mask is to implant only in certain parts of the wafer, using a suitably thick mask (i.e. that its R_p lies within the mask material)
- The thickness of the mask should be large enough that the tail of the implant profile in the silicon should not significantly alter the doping concentration (C_B)
- The resist thickness cannot exceed a maximum value to avoid the UV light giving non uniform exposure

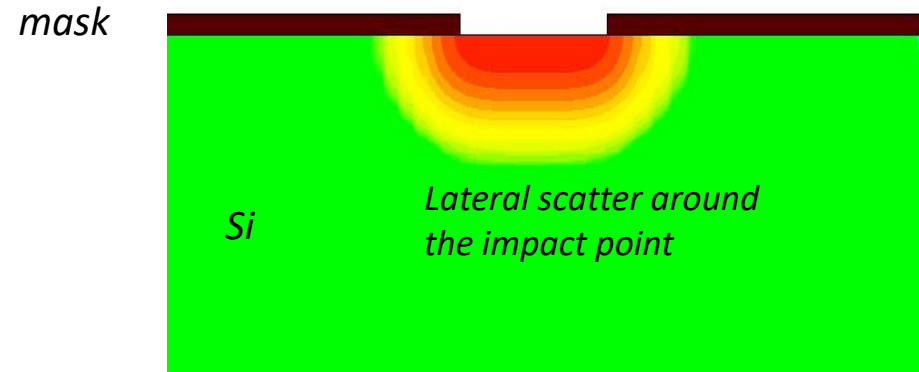

MATERIAL THICKNESS NEEDED TO MASK

At 200 KeV

	Poly	SiO ₂	Si ₃ N ₄	Al	Resist
Boron	0.9μm	1.0μm	0.61μm	0.9μm	1.0μm
Phosphorous	0.7μm	0.6μm	0.42μm	0.55μm	0.8μm
Arsenic	0.3μm	0.3μm	0.18μm	0.28μm	0.35μm
Antimony	0.2μm	0.2μm	0.16μm	0.18μm	0.25μm

At 100 KeV

	Poly	SiO ₂	Si ₃ N ₄	Al	Resist
Boron	0.65μm	0.7μm	0.42μm	0.7μm	0.7μm
Phosphorous	0.4μm	0.36μm	0.25μm	0.3μm	0.45μm
Arsenic	0.18μm	0.16μm	0.1μm	0.16μm	0.20μm
Antimony	0.12μm	0.11μm	0.07μm	0.10μm	0.14μm

FOR 0.0001% TRANSMISSION

Ion Implantation channeling

- During ions implantation in a periodic structure, directional effects due to nuclear scattering might confine the ions into regions minimizing interactions along the path.
- Channelling: Average penetration depth is larger, affecting the final doping profile

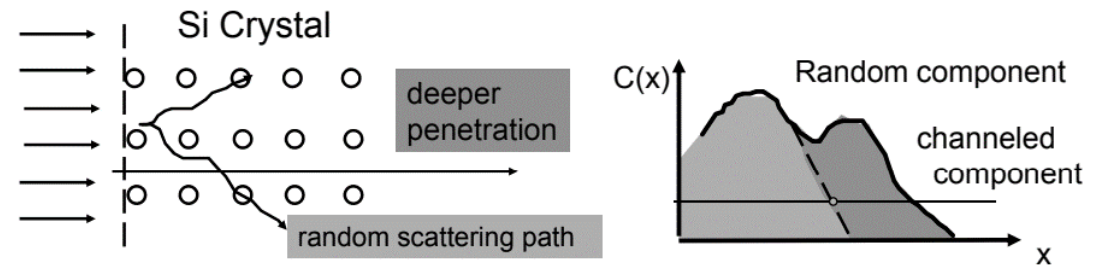
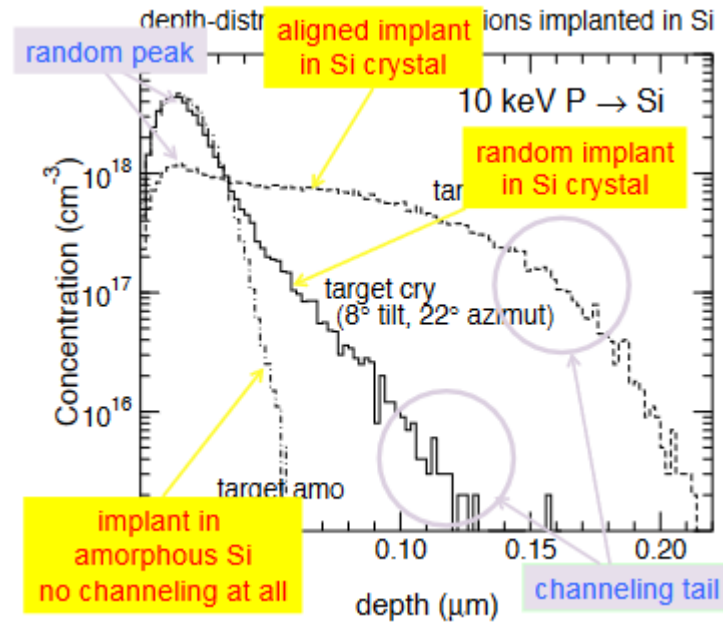

Ion Implantation channeling

To minimize channelling:

- **pre-amorphization** of the wafer via implantation
- the wafer is **tilted** by some degrees with respect to ion beam: the value of the critical angle below which there is channelling depends on crystal orientation and energy of the ion. In practice a tilting angle of **7** degrees is used

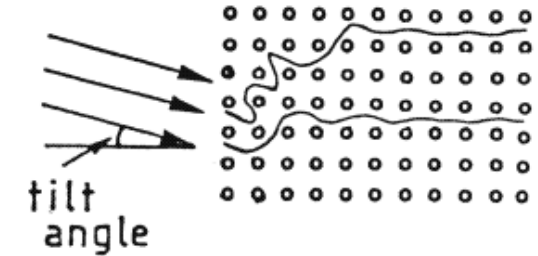
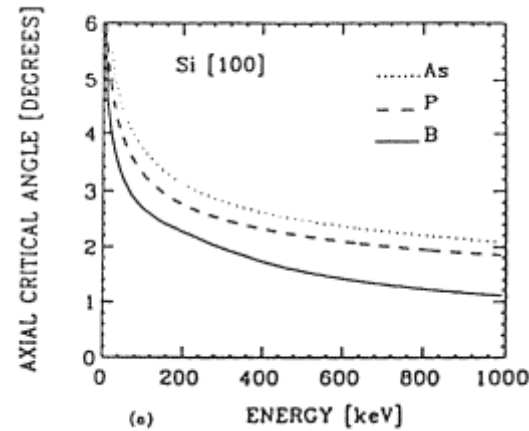

Step 1
High dose Si+
implantation to convert
surface layer into
amorphous Si
1 E15/cm²

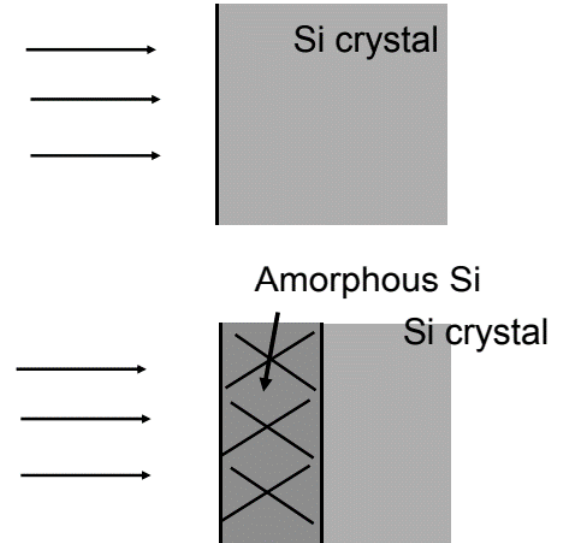

Step 2
Implantation of
desired dopant
into amorphous
surface layer
B+

Ion Implantation damage and annealing

- Ion implantation creates defects in the target crystal, by displacing atoms from their regular lattice sites (see **radiation damage lectures**)
- The elementary radiation defect consists of Frenkel defect, i.e. displaced atom (interstitial) plus the related vacancy
- More complex defects form as a result of accumulation and clustering of interstitials and vacancies (divacancies V-V, vacancy impurities, like V-O, As-I...)

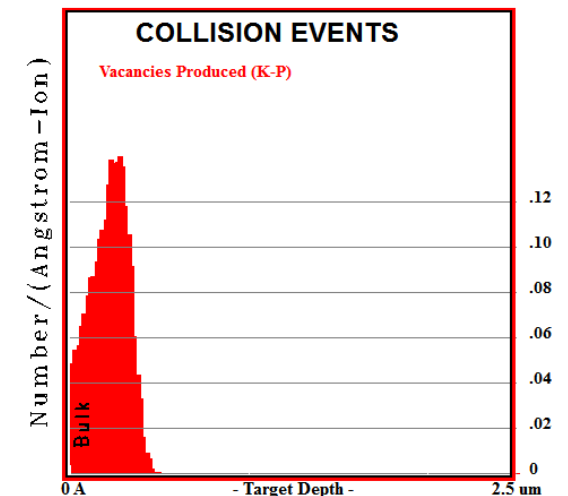
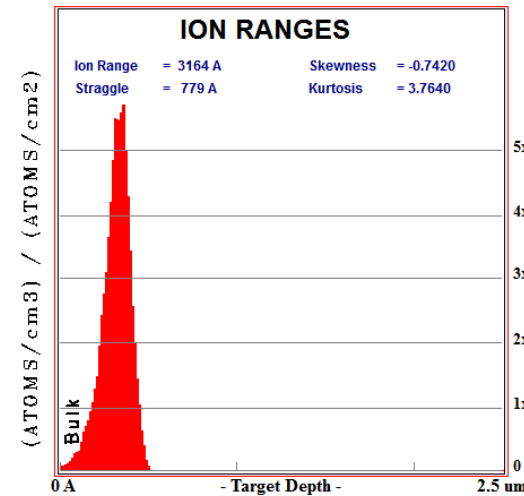
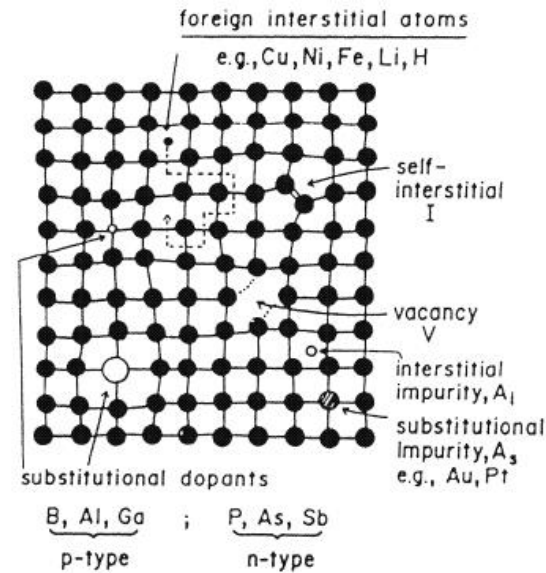

Ion Implantation damage and annealing

- After the implantation process, a thermal treatment is required to electrically activate the dopant (i.e. to have them moved to substitutional positions) and to restore the crystalline order of the semiconductor
- Annealing at high temperature ($\sim 1000^\circ\text{C}$) could result in perfect crystal, but leads to dopant diffusion. Particularly serious issue in modern technologies, where very shallow junctions are used

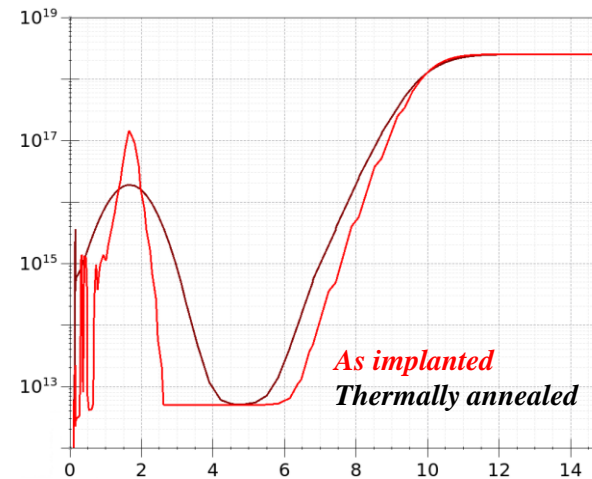

An example of doping profile from ^{11}B implantation in $\langle 100 \rangle$ Si, as implanted and after thermal annealing

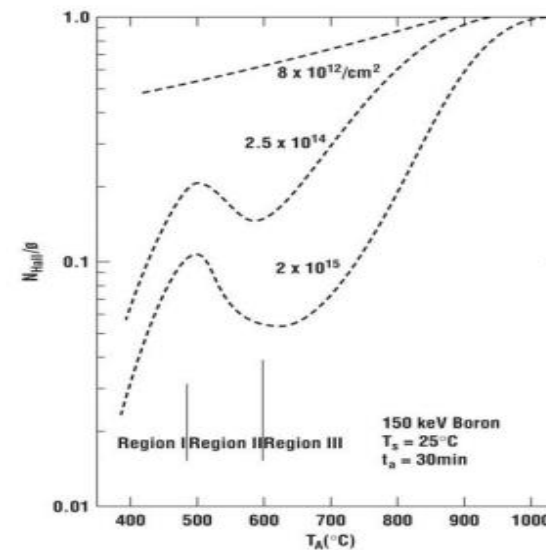

Isochronal annealing of boron. The ratio of the free-carrier to dose (fraction of boron atoms located in substitutional lattice points) is plotted versus the anneal temperature for three doses of boron.

Ion Implantation damage and annealing

- Activation energy for removal of point defects (V and I) usually higher than that of impurity diffusion.
- Different slopes in Arrhenius plots allow to use high temperature to enhance annealing and depress diffusivity: Rapid Thermal Annealing (**RTA**)

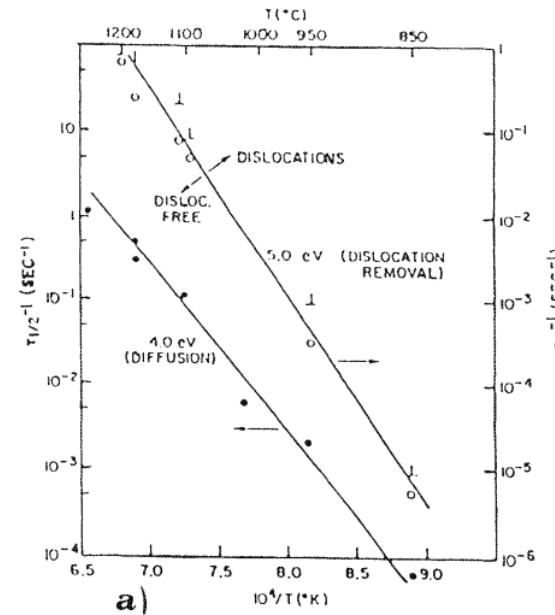

a) Dislocation removal rate in As implanted Si and As diffusivity vs. $1/T$

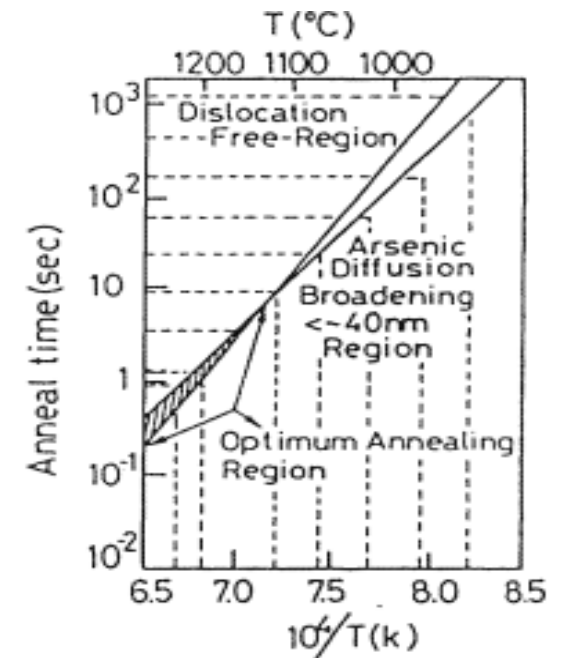

Ion Implantation damage and annealing

- Rapid thermal annealing of wafers (**RTA**) optimizes the defects suppression, whilst minimizing dopants diffusion
- Wafers are rapidly heated by lamps (10's kW) to 1000 C for 1 – 20 secs max
- Various methods to measure the wafer temperature (optical, acoustic)

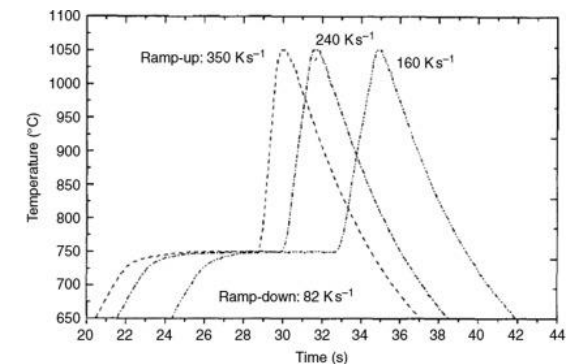
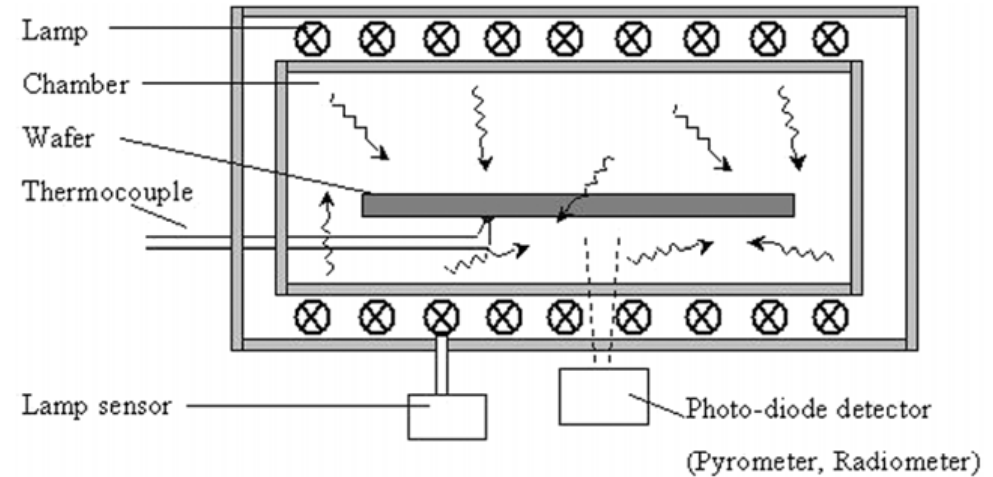

<https://photonexport.com/rapid-thermal-processing/>

Metallization

- Once devices have been fabricated in the wafer (Front End of Line), metal layers are deposited to form the conductive connections
- Modern technologies moved from Al to Cu to reduce resistivity in interconnect in Back End of Line (BEOL). This is a more complex process (Dual Damascene process) than sputtering

Schottky diode on P-type Si wafer

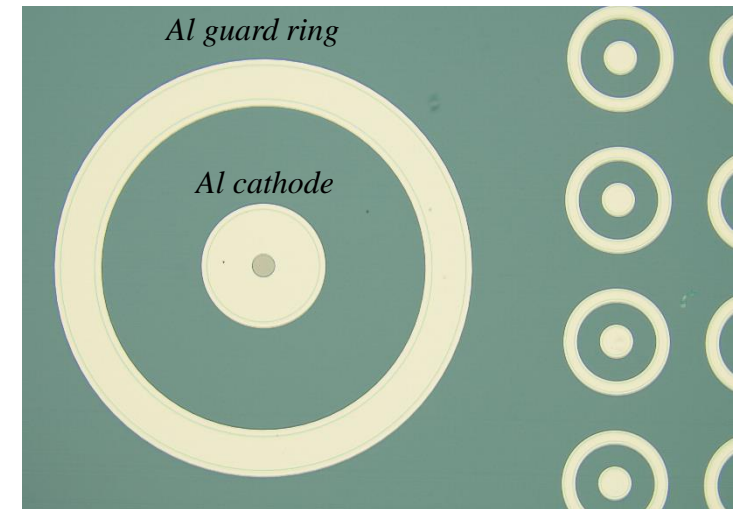
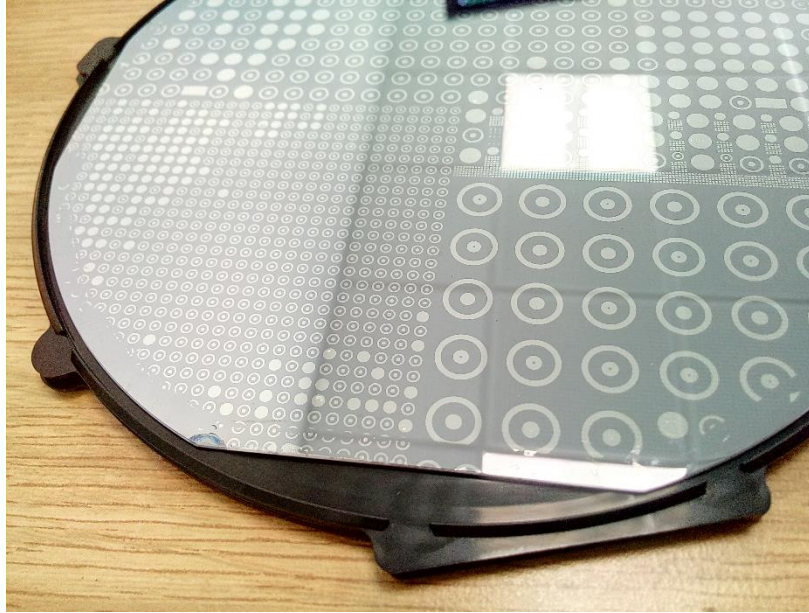

Metallization

- Sputtering (**PVD**, Physical Vapor Deposition) is one of the most common method to deposit thin film of metal
- Good step coverage obtained by reducing the mean free path of sputtered atoms (increasing Ar ions, magnetron sputtering)
Sputtering also used to clean wafer before deposition, by Ar⁺ etching

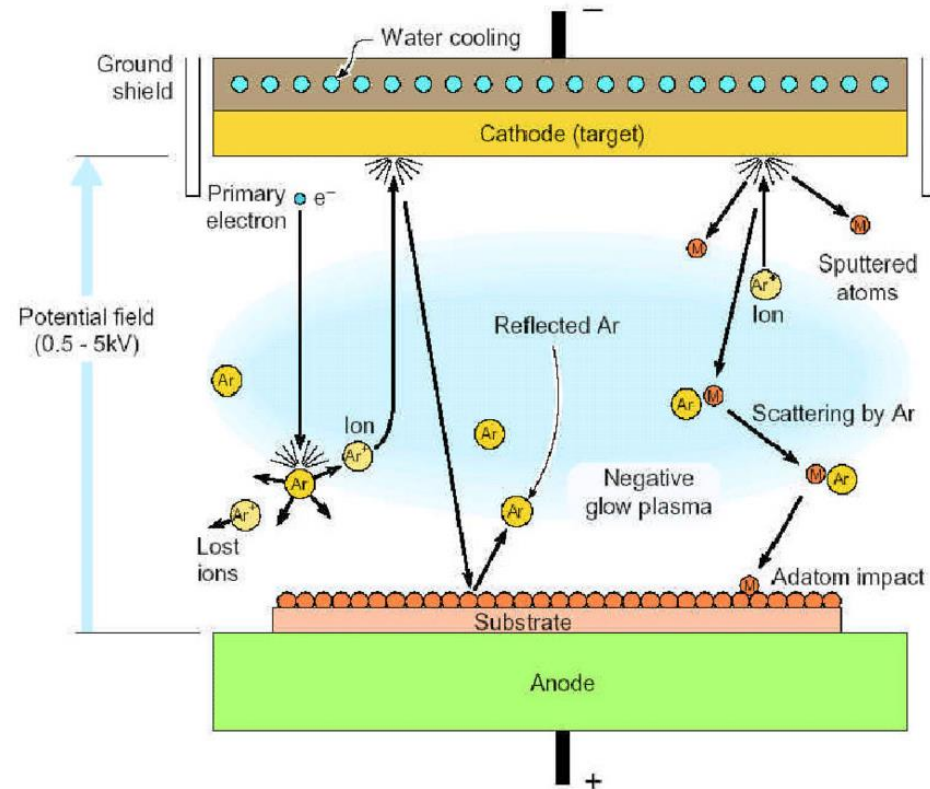

Cathode (target -) is the material to deposit, generally cooled

An inert gas (Ar) is ionized, accelerated and collides with the target. Ejected atoms have energies ~ 10's eV

Some atoms sputters off and, after scattered paths, land and deposit onto the wafer (+)

Thank you

giulio.villani@stfc.ac.uk

- Resist development
- Etching
 - Wet and dry
- Ion Implantation
 - Characteristics, tools and equipment
 - Ion interactions, masking and channeling, doping profiles
 - Implantation damage and annealing required
- Metallization
 - Tools and equipment

Example

- Estimate the dose ϕ , energy E required for B11 to get an implanted depth $x_{pk} = 0.3 \mu\text{m}$ with $N_{Apk} = 5e12 \text{ cm}^{-3}$ in a Silicon substrate of doping $N_{abulk} = 1e14 \text{ cm}^{-3}$
- Assume both R_p and $\Delta R_p \propto \sqrt{E}$
- $R = 4 \cdot 10^{-3} E - 7.8 \cdot 10^{-6} E^2$
- $\Delta R = 1.4 \cdot 10^{-3} E - 4.4 \cdot 10^{-6} E^2$

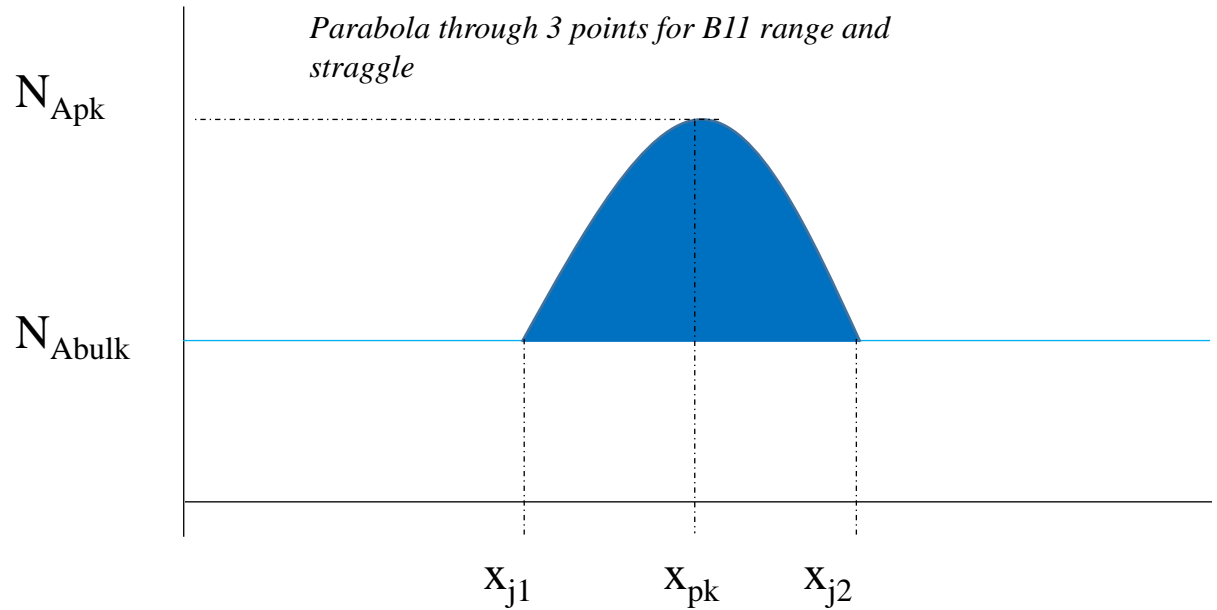
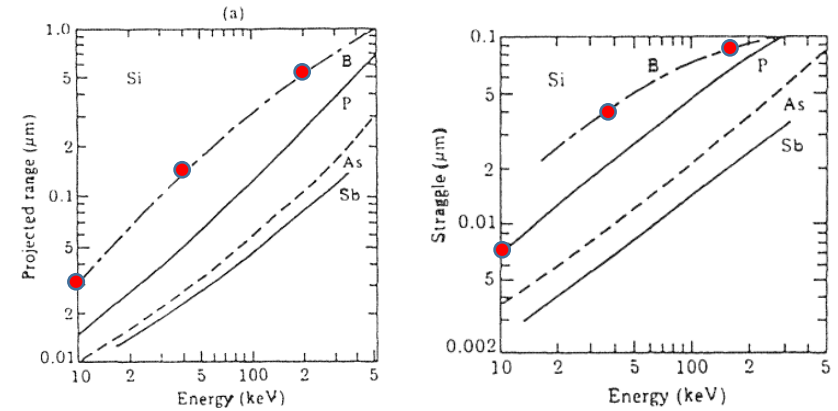

Example

- From expression of $R_p = 0.3 \mu\text{m}$ determine E required for 0.3 depth :

$E = 92 \text{ keV}$, from which $\Delta R_p = 0.0915 \mu\text{m}$

- Assuming Gaussian profile, the dose required is then: $\int_0^L N(x) = Q = \sqrt{2\pi} \Delta R_p N_{pk} \approx 2.5 * 0.0915 * 1e-4 * 5e16 = \mathbf{1.14e12 \text{ cm}^{-2}}$

- $R = 4 \cdot 10^{-3} E - 7.8 \cdot 10^{-6} E^2$
- $\Delta R = 1.4 \cdot 10^{-3} E - 4.4 \cdot 10^{-6} E^2$

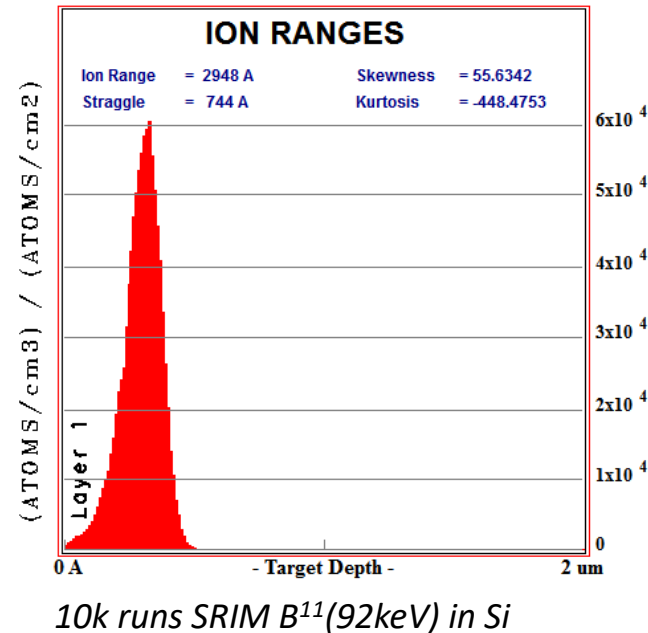

$$\langle R \rangle = 294.8 \text{ nm}$$

$$\Delta R = 74.4 \text{ nm}$$

$$\Phi = \frac{5 \cdot 10^{16}}{6 \cdot 10^4} = 0.83 \cdot 10^{12}$$

Appendix: Ion Implantation

- The many-body problem of **ion-solid interaction** where one ion ($M_1, n_1 \neq Z_1$) interacts with all target atoms M_2 nuclei and electrons in a solid is practically intractable: some simplifying assumptions are introduced:
- **Classical mechanics** used to describe the motion of ion and nuclei
- **Binary collision approximation (BCA)** to calculate the ion trajectories
- **Adiabatic approximation** : nuclear and electronic systems are treated separately

$$H\Psi(\mathbf{R}_1, \mathbf{R}_{2,k}, \mathbf{r}_{1,i}, \mathbf{r}_{2,k,j}, t) = i\hbar \frac{\partial}{\partial t} \Psi(\mathbf{R}_1, \mathbf{R}_{2,k}, \mathbf{r}_{1,i}, \mathbf{r}_{2,k,j}, t)$$

$$M_1, Z_1, \mathbf{R}_1, \mathbf{r}_{1,i} \quad (i = 1, n_1 \quad n_1 \neq Z_1)$$

$$M_2, Z_2, \mathbf{R}_{2,k}, \mathbf{r}_{2,k,j} \quad (j = 1, Z_2 \quad k = 1, N)$$

Appendix: Ion Implantation

- **Classical mechanics** : ions move as *classical point-like* particles: e.g. for lightest ion B¹¹ @ E =10 keV
- Usually in implantation processes ion energy is not large enough to penetrate the coulomb barrier of the target nuclei, i.e. no nuclear reactions.

$$\lambda_{ion}[nm] = \frac{h}{M_1 v} = \frac{2.87 \times 10^{-2}}{\sqrt{M[amu]E[eV]}}$$

$\lambda = 8.6 \cdot 10^{-5} [nm] \ll 0.54 [nm]$, Si lattice parameter

B¹¹ @ 1MeV $\beta = 0.01$

Appendix: Ion Implantation

- **Binary collision approximation** : ion movement is described as a series of successive elastic two-body Coulombic interactions, using a screened potential (i.e. negative charge of ion and target reduces the Coulomb potential strength)

