

Device Structures: Gain layers

Francisca Muñoz Sánchez

University of Manchester

26th May 2026

Content

- Motivation
- Time of arrival measurement
 - Time resolution
- Amplification layers in silicon devices
- Devices examples:
 - APD
 - SPAD
 - SiPM
 - LGADS
 - Gain without doping

Main references:

- M. Carulla Areste PhD Thesis : [“Thin LGAD timing detectors for the ATLAS experiment”](#), 2019
- G. Kramberger. [“LGADs for timing detectors at HL-LHC”](#). CERN Detector seminar, 2021

Full bibliography on last slide

Motivation

- HL-LHC [1]:
 - Instantaneous luminosity: $7.5 \cdot 10^{34} \text{ cm}^2 \text{ s}^{-1}$.
 - Pile-up : $\mu \sim 200 \rightarrow 2600$ tracks (collision of interest + all the other collisions):
 - 1.6 collisions/mm
 - Over 50 mm
 - Primary vertices identification more difficult (especially for events of interest with tracks on the forward region)
- Longitudinal track impact parameter (z_0) resolution becomes crucial (For $|\eta| = 2$ in ITk is a few mm) [2].

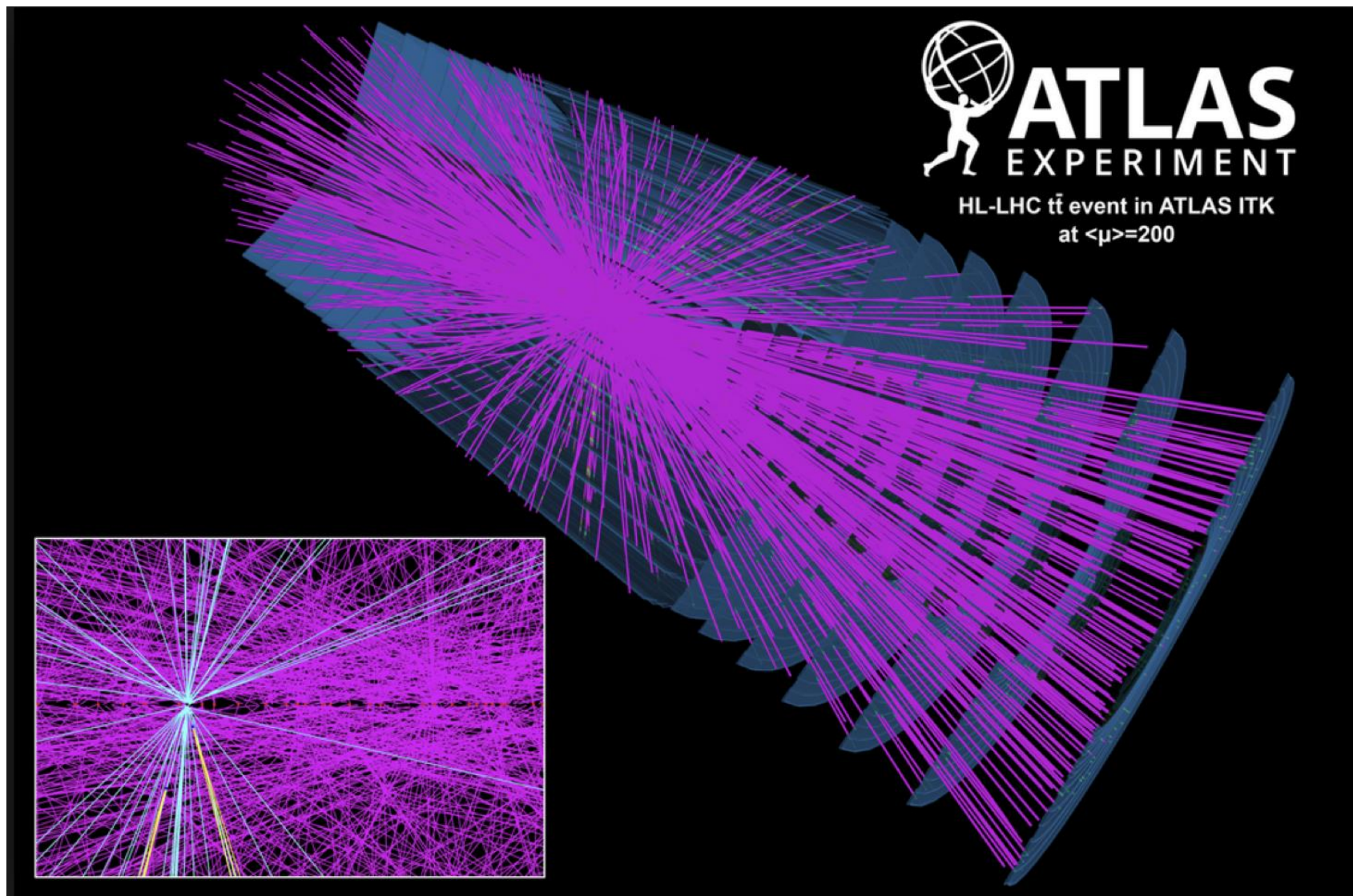

Motivation

- Longitudinal (z_0) and transverse (R_0) track impact parameter resolution
- Collisions (interactions) spread in time (180 ps) can help to reduce the pile-up
- Achieving time resolution ~ 30 ps allows going from $\mu \sim 200$ to 40
- Impact on the physics analysis
- Factor 5 to 10x improvement on vertex merging rate (9 achieved)
- Factor 3 to 5x reduction of false positive on track to vertex association (3 achieved)
- Significant reduction of combinatoric in the algorithms (among other advantages) [3]
- Timing information:
 - Per Hit \rightarrow more challenging
 - Per Track \rightarrow 1 timing layer (HL-LHC)

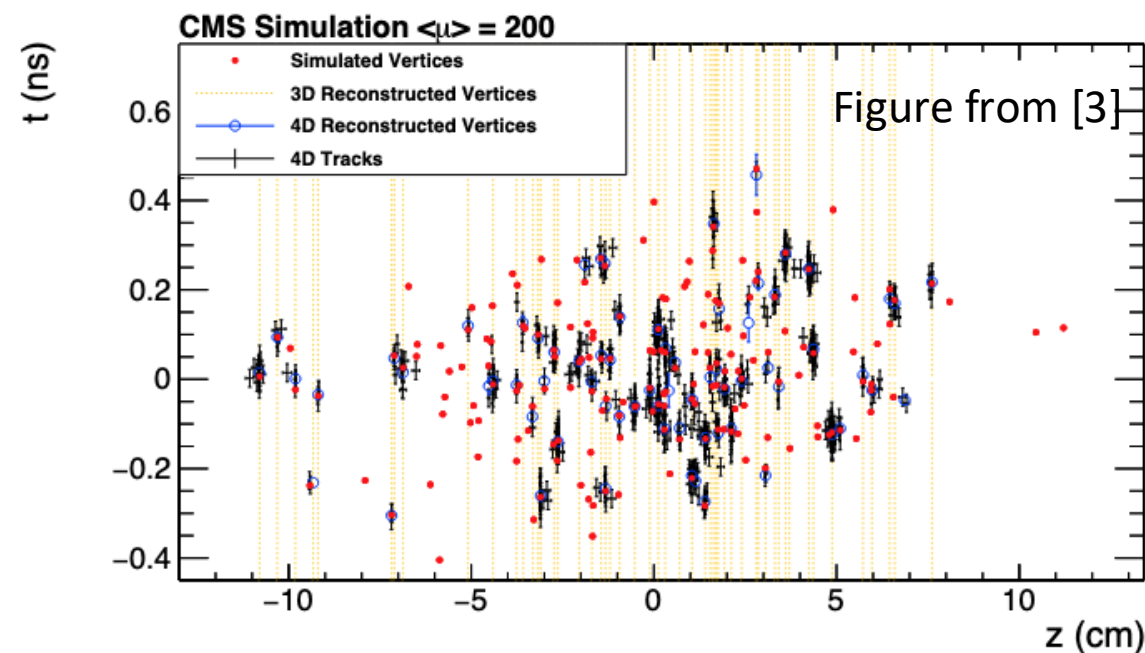
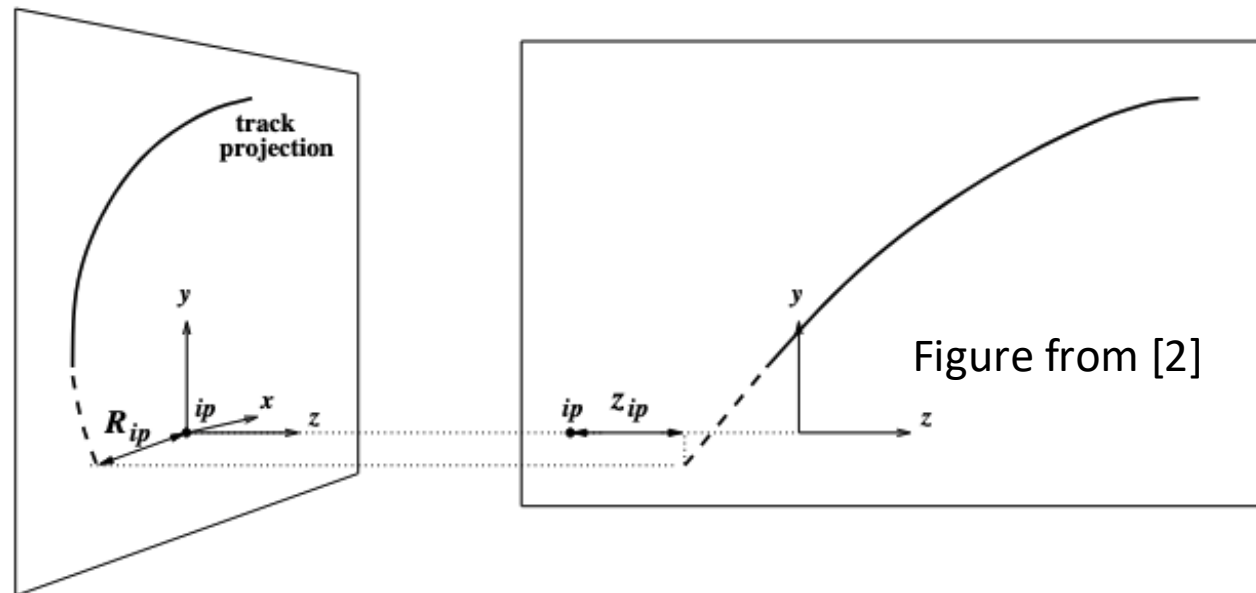

Motivation outside Particle Physics

- Medical applications could also benefit of a better time resolution:
 - Therapeutic beams monitoring and dosimetry [4,5]
 - Diagnosis (PET, pCT scans) can also benefit of having higher time resolution (100ps as today) [6,7]
 - In vivo monitoring of the dose with high spatial resolution

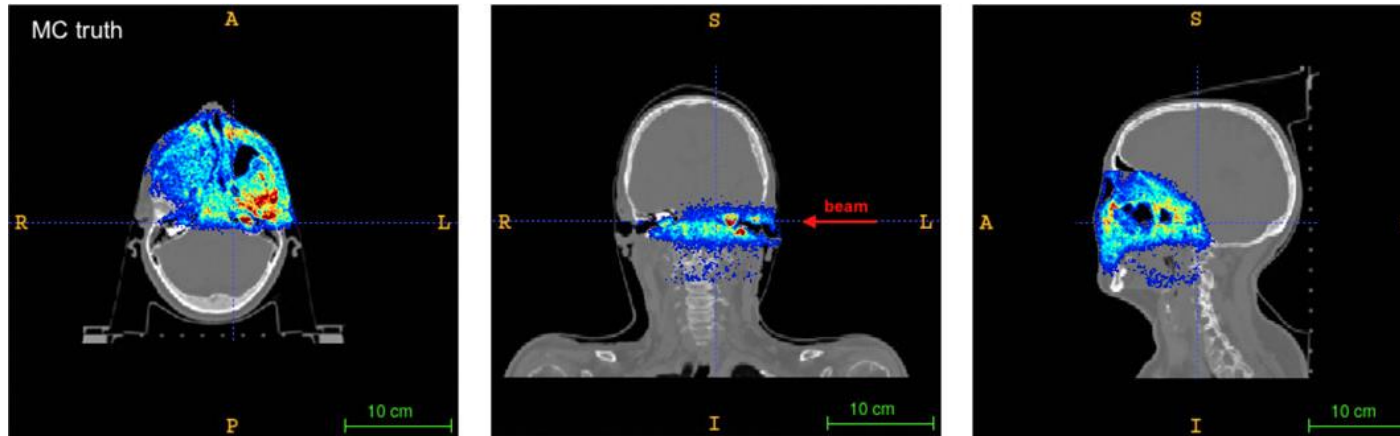
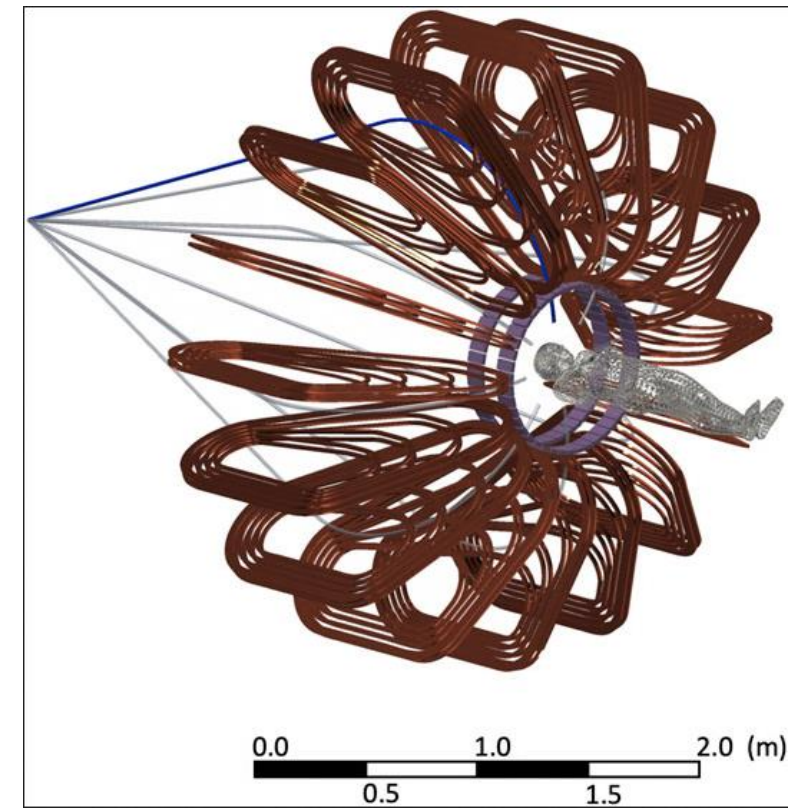

fmunoz@cern.ch

Figures from [6]

Time measurement

- Fast detectors. Rapid charge collection. Big charge
- Time measurement techniques:
 - Leading Edge (LE), time at what the pulse pass a threshold. When input pulses belong to a small dynamic range (very similar pulses expected)
 - Constant fraction discrimination technique (CFD). When input pulses belong to a big dynamic range (very different pulses)

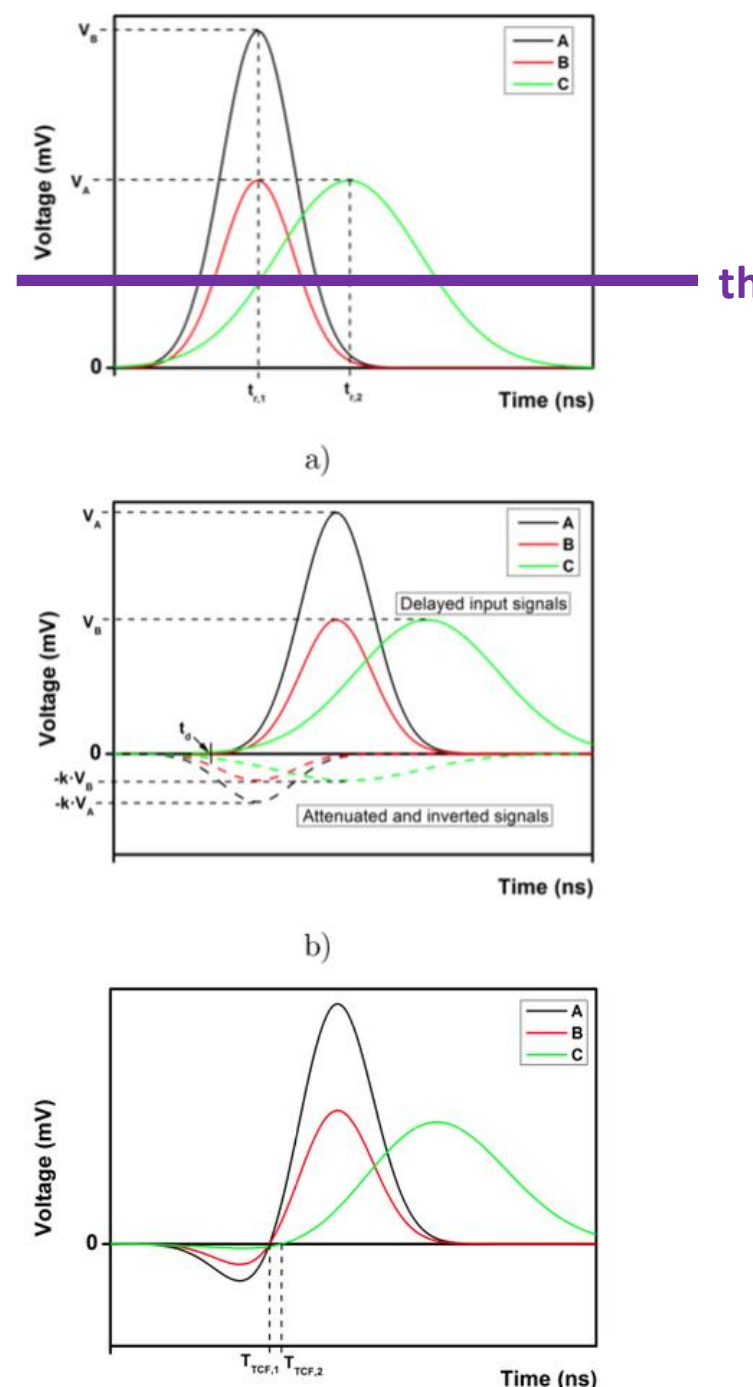

Leading Edge approach can lead to huge measurement differences for different signals

CDF technique mitigates it applying certain logic to signals (delay, attenuation, inversion and addition). It works better for signals with different amplitude.

Figure from [8]

Time resolution [8]

- All the components that change the shape of the signal introduce uncertainties
- Time resolution is:

$$\sigma_t^2 = \sigma_{time\ walk}^2 + \sigma_{Landau\ noise}^2 + \sigma_{jitter}^2 + \sigma_{distortion}^2 + \sigma_{TDC}^2$$

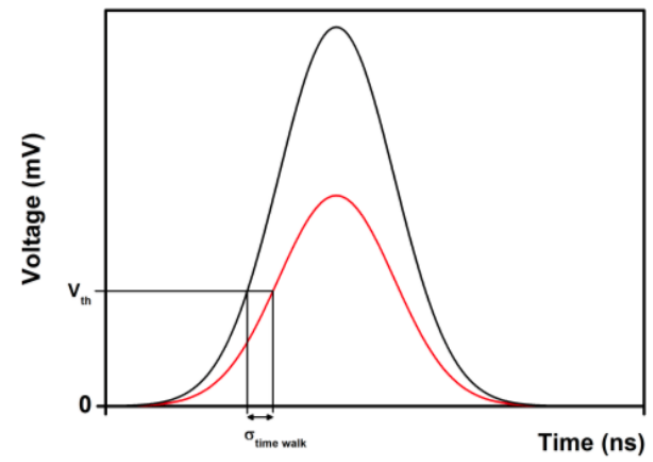
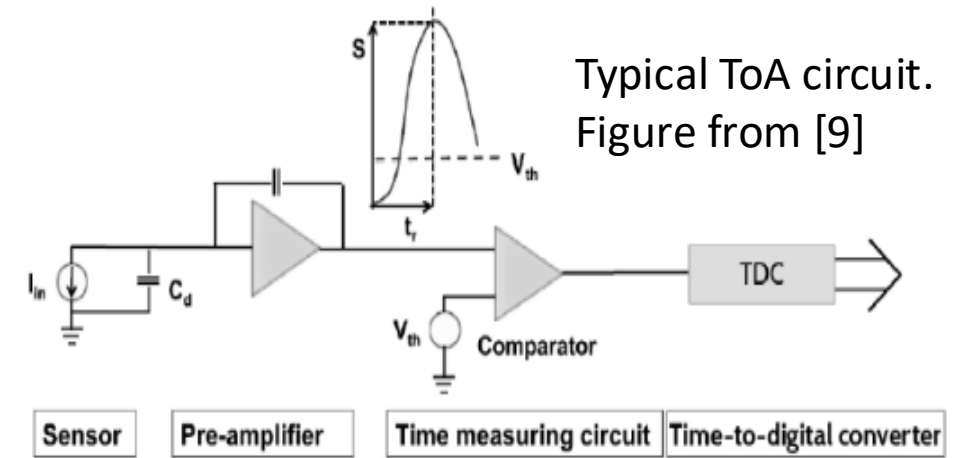

$$\sigma_{time\ walk} = [t_d]_{RMS} = \left[\frac{V_{th}}{S/t_{rise}} \right]_{RMS} \propto \left[\frac{N \cdot \sigma_N}{dV/dt} \right]_{RMS}$$

Time resolution [8]

- All the components that change the shape of the signal introduce uncertainties
- Time resolution is:

$$\sigma_t^2 = \sigma_{time\ walk}^2 + \sigma_{Landau\ noise}^2 + \sigma_{jitter}^2 + \sigma_{distortion}^2 + \sigma_{TDC}^2$$

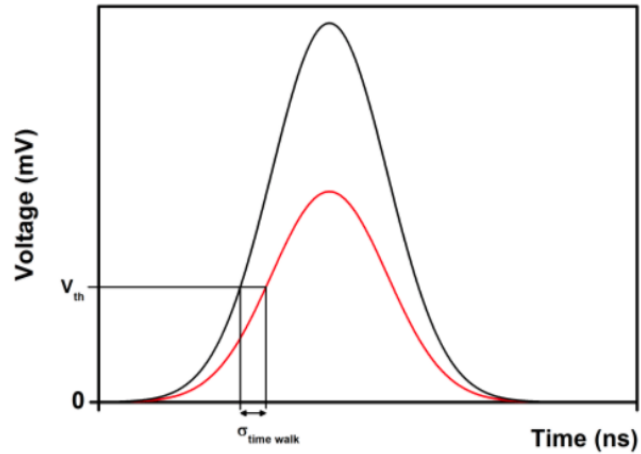
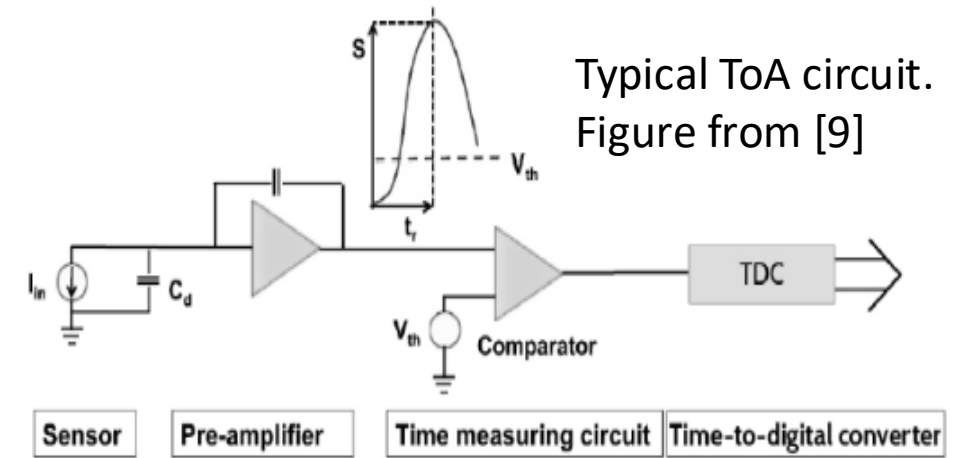

$\sigma_{Landau\ noise}$: Variations on the energy deposited.
Thinned sensors \rightarrow smaller variations

$$\sigma_{time\ walk} = [t_d]_{RMS} = \left[\frac{V_{th}}{S/t_{rise}} \right]_{RMS} \propto \left[\frac{N \cdot \sigma_N}{dV/dt} \right]_{RMS}$$

Time resolution [8]

- All the components that change the shape of the signal introduce uncertainties
- Time resolution is:

$$\sigma_t^2 = \sigma_{time\ walk}^2 + \sigma_{Landau\ noise}^2 + \sigma_{jitter}^2 + \sigma_{distortion}^2 + \sigma_{TDC}^2$$

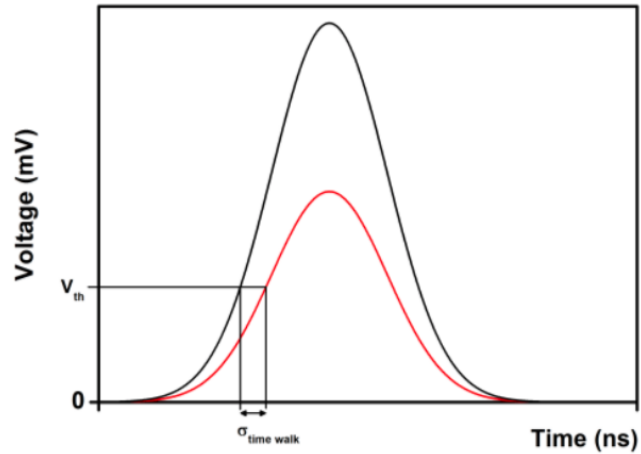
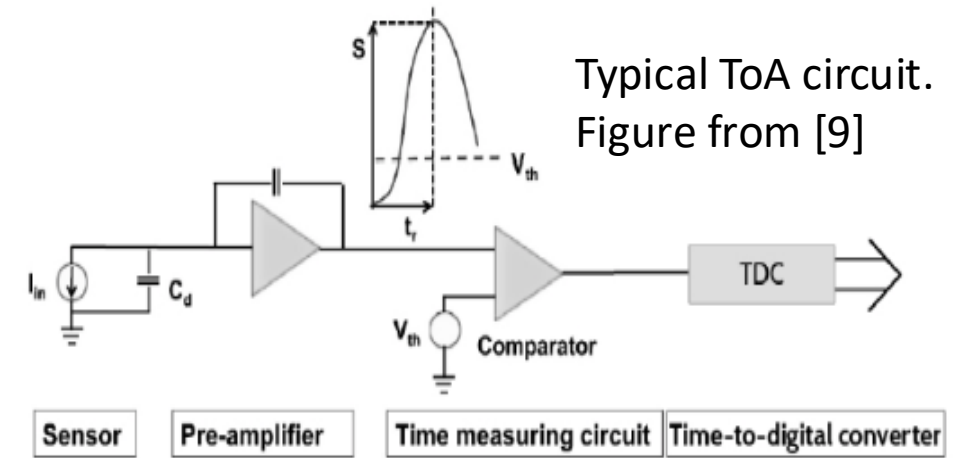

$\sigma_{Landau\ noise}$: Variations on the energy deposited. Thinned sensors \rightarrow smaller variations

σ_{jitter} : Uncertainties on the Time of Arrival (ToA) for constant pulses. Signal level is modulated by noise; the time of threshold varies accordingly.

$$\sigma_t = \frac{\sigma_n}{(dV/dt)_{V_{th}}} \approx \frac{1}{S/N} t_r$$

$$\sigma_{time\ walk} = [t_d]_{RMS} = \left[\frac{V_{th}}{S/t_{rise}} \right]_{RMS} \propto \left[\frac{N \cdot \sigma_N}{dV/dt} \right]_{RMS}$$

Time resolution [8]

- All the components that change the shape of the signal introduce uncertainties
- Time resolution is:

$$\sigma_t^2 = \sigma_{time\ walk}^2 + \sigma_{Landau\ noise}^2 + \sigma_{jitter}^2 + \sigma_{distortion}^2 + \sigma_{TDC}^2$$

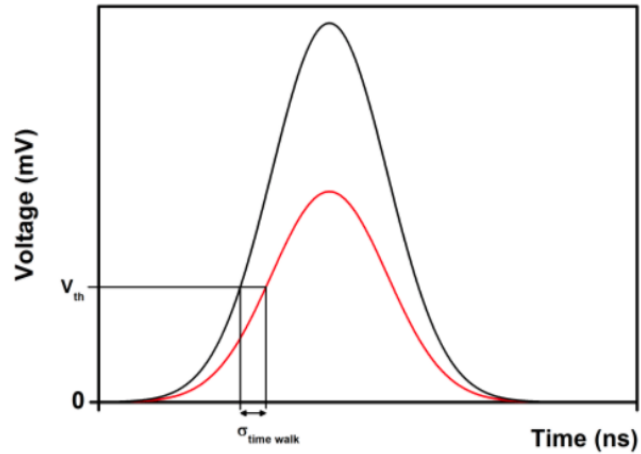
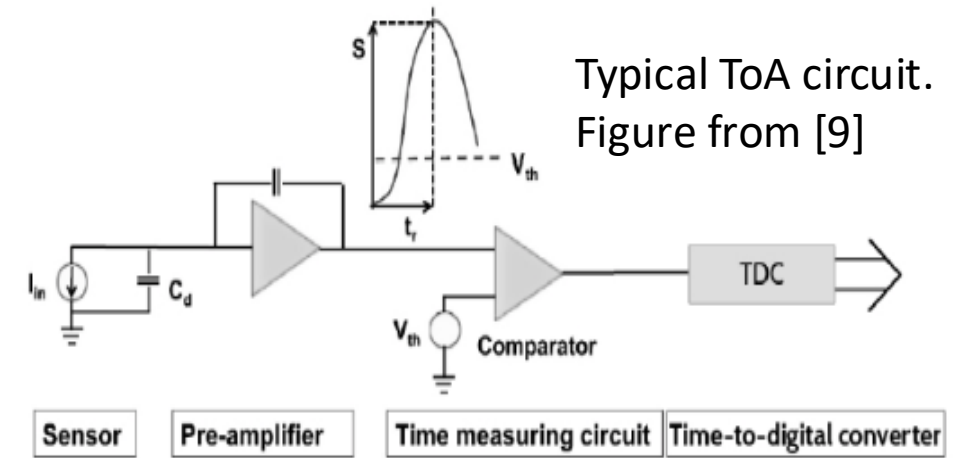

$\sigma_{Landau\ noise}$: Variations on the energy deposited. Thinned sensors \rightarrow smaller variations

σ_{jitter} : Uncertainties on the Time of Arrival (ToA) for constant pulses. Signal level is modulated by noise; the time of threshold varies accordingly.

$\sigma_{distortion}$: due to the sensor geometry, field as homogeneous as possible

$$\sigma_t = \frac{\sigma_n}{(dV/dt)_{V_{th}}} \approx \frac{1}{S/N} t_r$$

$$\sigma_{time\ walk} = [t_d]_{RMS} = \left[\frac{V_{th}}{S/t_{rise}} \right]_{RMS} \propto \left[\frac{N \cdot \sigma_N}{dV/dt} \right]_{RMS}$$

Time resolution [8]

- All the components that change the shape of the signal introduce uncertainties
- Time resolution is:

$$\sigma_t^2 = \sigma_{time\ walk}^2 + \sigma_{Landau\ noise}^2 + \sigma_{jitter}^2 + \sigma_{distortion}^2 + \sigma_{TDC}^2$$

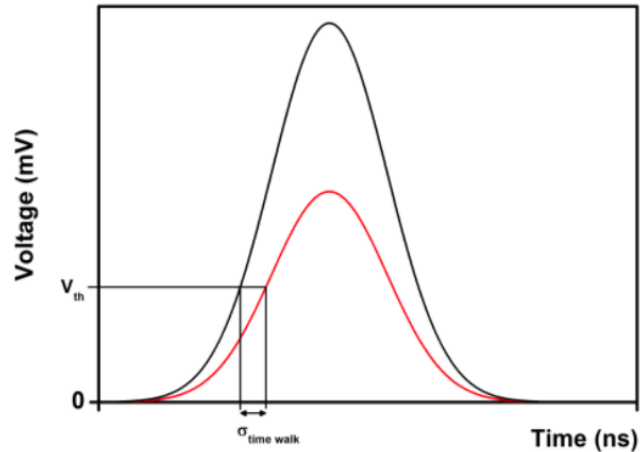
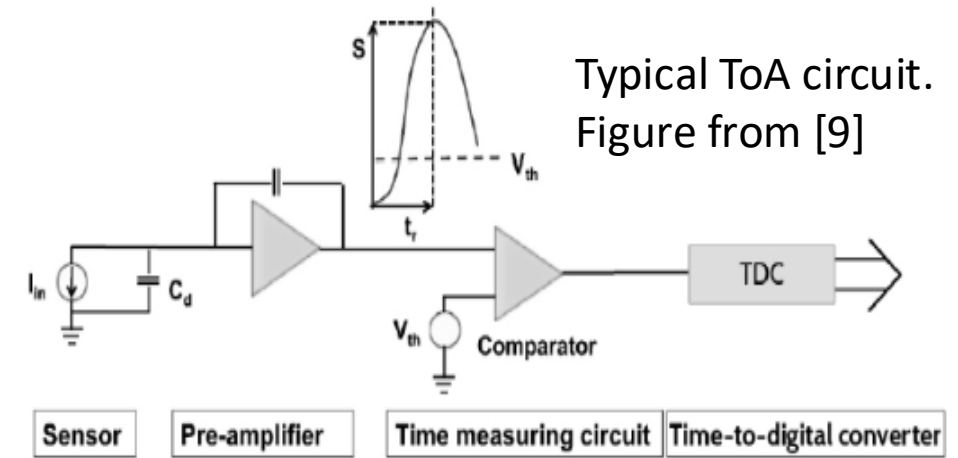

$\sigma_{Landau\ noise}$: Variations on the energy deposited. Thinned sensors \rightarrow smaller variations

σ_{jitter} : Uncertainties on the Time of Arrival (ToA) for constant pulses. Signal level is modulated by noise, the time of threshold varies accordingly.

$\sigma_{distortion}$: due to the sensor geometry, field as homogeneous as possible

σ_{TDC} : time info is digitized into a bin of width Δt . $\sigma_{TDC} = \Delta t / \sqrt{12}$

Q1. What would be the ideal conditions? When can we have the best time resolution?

$$\sigma_t = \frac{\sigma_n}{(dV/dt)_{V_{th}}} \approx \frac{1}{S/N} t_r$$

$$\sigma_{time\ walk} = [t_d]_{RMS} = \left[\frac{V_{th}}{S/t_{rise}} \right]_{RMS} \propto \left[\frac{N \cdot \sigma_N}{dV/dt} \right]_{RMS}$$

Timing detectors

- Cherenkov gas/quartz detector. Cherenkov **light** hits a photocathode in a **Microchannel Plate-Photomultiplier Tube (MCP-PMT)**, converts on electron and it gets multiplied with $\sigma_t = 15$ ps. (not radiation hard and low granularity)
- LYSO crystal + SiPM detectors. Scintillating **light**. $\sigma_t = 15$ ps. VERY USED in PET
- Diamond sensors. Very low signal, require low noise amplifiers, $\sigma_t = 100$ ps
- Silicon sensors with amplification. APD, SPAD, SiPM, LGAD, I-LGAD

Amplification layer in silicon devices [11]

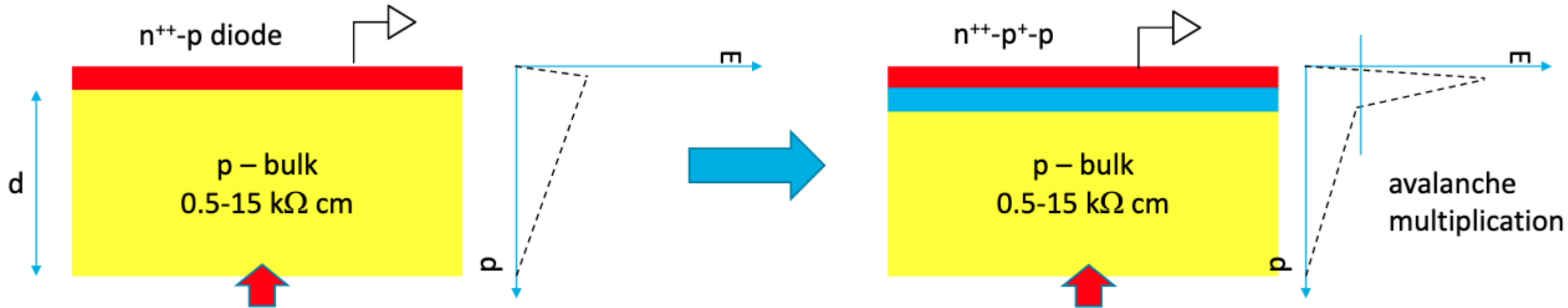

- From a pn-junction structure n-type on a very low doped p-type silicon
- Dopants are diffused just under the n layer to create a p^+ -type layer that will act as amplification layer.
- Electrons injected from the bottom, accelerate on the p^+ layer (high E) and multiply creating e-h pairs
- Important characteristic of the amplification layers are homogeneity, depth, width, doping and doping change with irradiation (depending on the application)
- Gain should stay in a range where S/N is high (time resolution)
- To have a **big signal** will always benefit the time measurement

Examples of silicon devices with Gain

Avalanche photodiode (APD)

- Very similar to a p-on-n diode but with an amplification layer [10]:
 - Next to the depletion area (junction)
 - High E
 - Electrons accelerate and generate more carriers
 - Avalanche effect
 - Very high voltages to operate them
 - Sensitive to very low signals
 - Can operate in magnetic fields (unlike PMT)
 - Optimized for light detection
 - $V \sim 1$ kV, $G \sim 200$

Q2. Can APDs be used in HEP? If yes, on what detectors? Why?

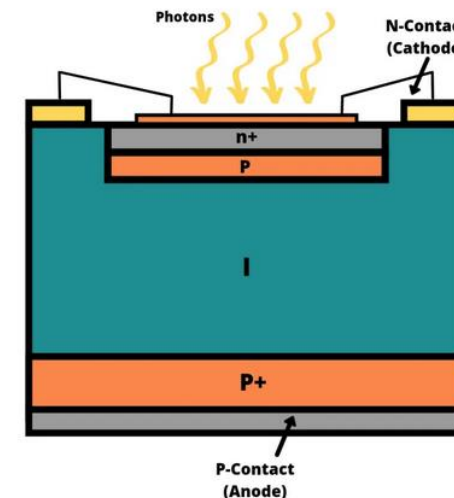
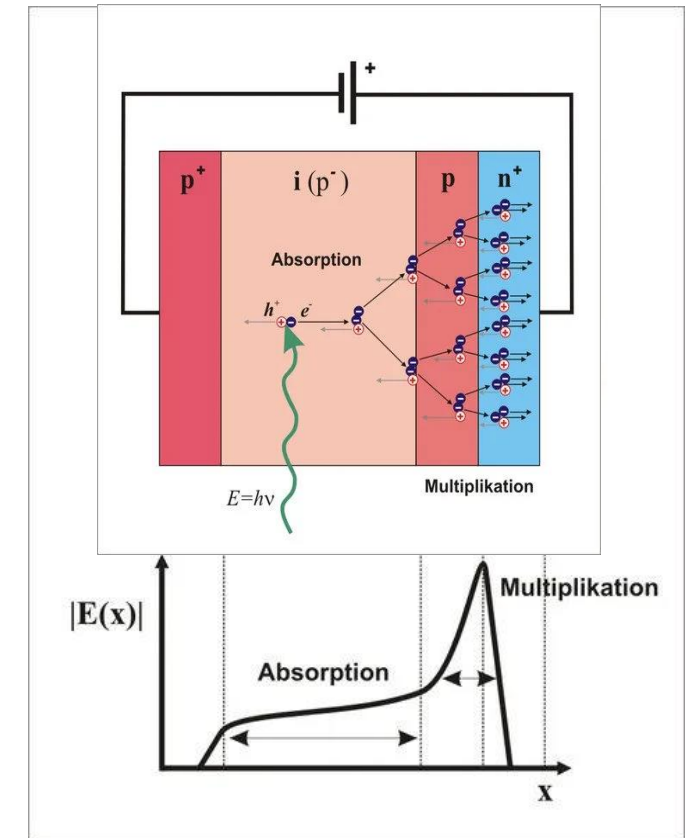

Deep Diffused Avalanche photodiode (DD-APD)

- Ongoing R&D effort on DD-APD [12,13]
- Having the pn-junction and gain layer deep in the bulk avoids surface noise contribution and early breakdowns
- $V \sim 1 - 2$ kV, $G \sim 500$
- Higher S/N than APDs

Q3. What are the advantages and disadvantages of having very big gains?

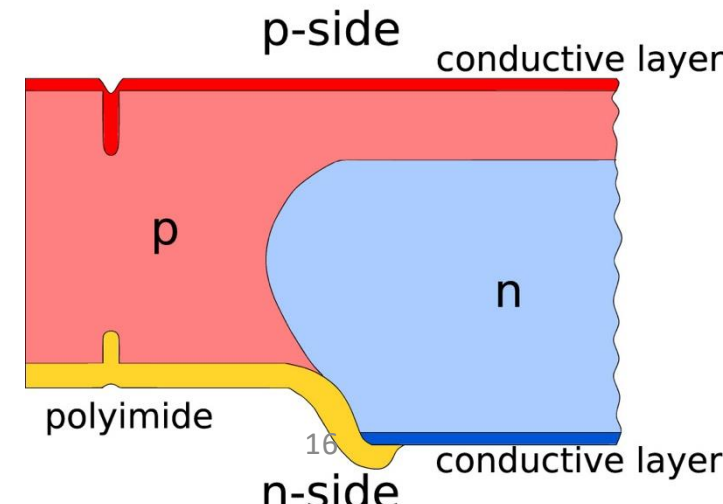
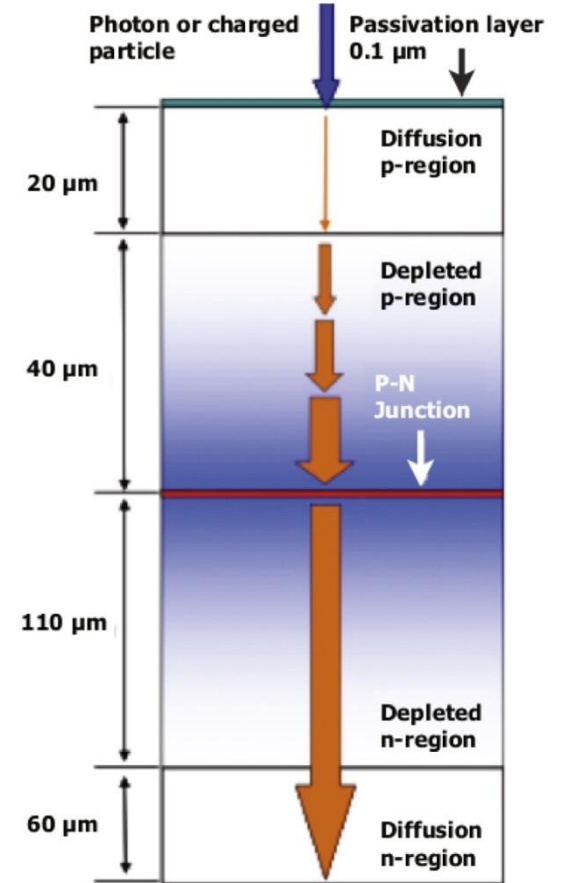

Single photon avalanche diode (SPAD) [14]

- SPADs are APDs operated well over their breakdown voltage. Geiger mode.
- APDs are biased just below V_B in order to have a non-diverging multiplication process but a linear multiplication of the photo-generated carriers (left side).
- Instead SPADs are biased well above V_B so that one photo-generated carrier can trigger a diverging avalanche process, leading to a macroscopic detectable output current (right side).
- In APDs, the avalanche finishes with the interaction (no photon or charged particle).
- In SPADS, they require to reset the device to stop the signal “Quenching”. Electronics required (a resistor in series can quench the SPAD). Dead time (~ 10 ns)
- The V increases gradually, a circuit to determine when is back in Geiger mode is needed (discriminator)

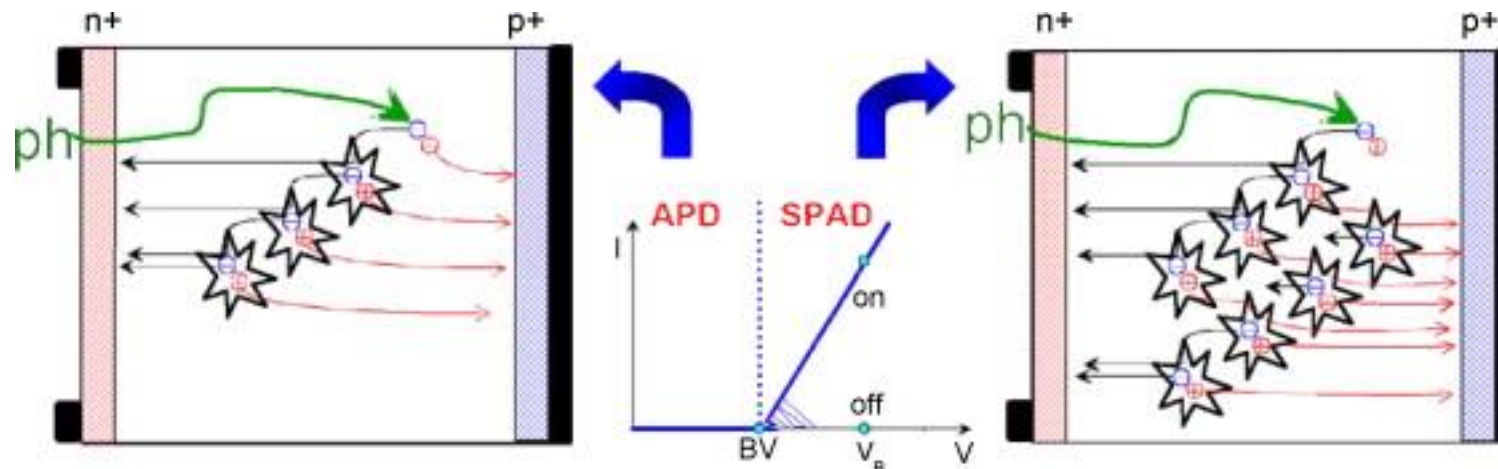

Silicon Photo-Multiplier (SiPM) [15]

- A SiPM is an array of micro-sized SPADs implemented in a common Silicon substrate with integrated quenching resistors ($\sim 1\text{M}\Omega$):
 - Sensitive size 1mm^2 on chip 1.5mm^2
 - Gain $2 \cdot 10^6$
 - $U_{\text{bias}} \sim 50\text{V}$
 - Recovery time $< 100\text{ ns/pixel}$
 - Number of pixels: $\sim 1000/\text{mm}^2$
 - Dynamic range of light intensity $\sim 10^3/\text{mm}^2$ (Each cell is binary; the device is analogue)
- Quantum efficiency (detection efficiency) not high enough depending on the wavelength
- Needs a radiator, particle interacts with matter emitting photons to be detected by the SiPM

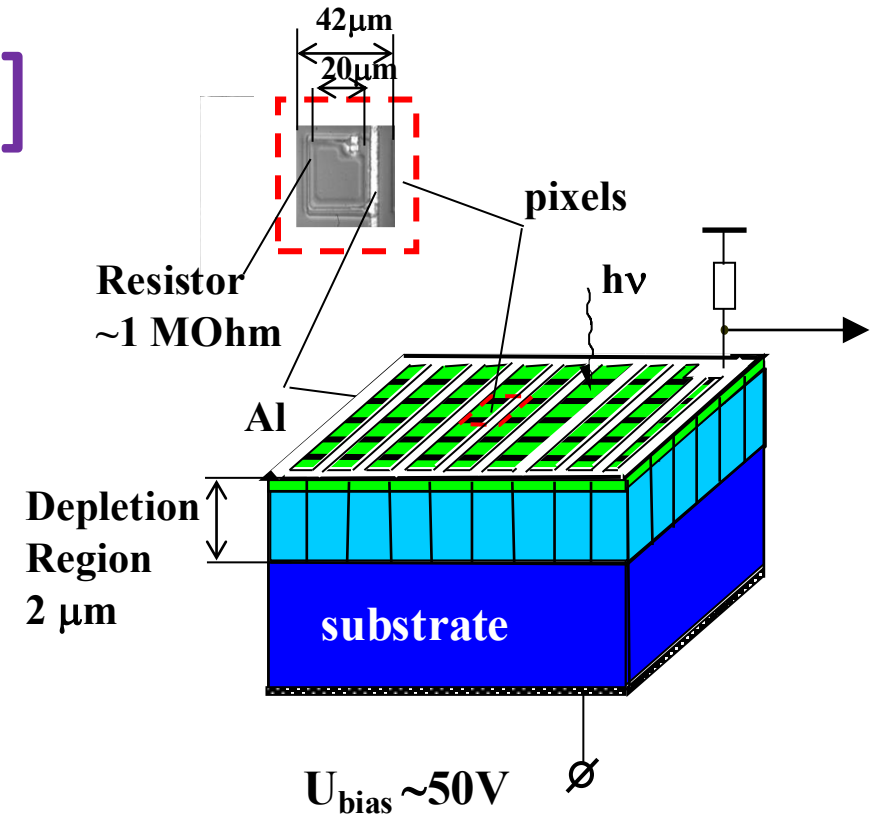

Low-Gain Avalanche Diode (LGAD). [8,11]

- LGAD detectors are customized Reach-through Avalanche Photodiodes (APD) for particle tracking and Time-of-arrival measurement:
 - $G \sim 10$
 - Work on the linear mode \rightarrow no need of quenching
 - No cross-talk
 - Signal no saturates dynamic range of the electronics
- Main parameters of the gain layer:
 - Implantation dose and final depth
 - Homogeneity of the layer is also crucial
- Requires termination structures (very high \mathbf{E} in the gain layer)
 - JTE \rightarrow Junction termination extension
 - FP \rightarrow Field plate

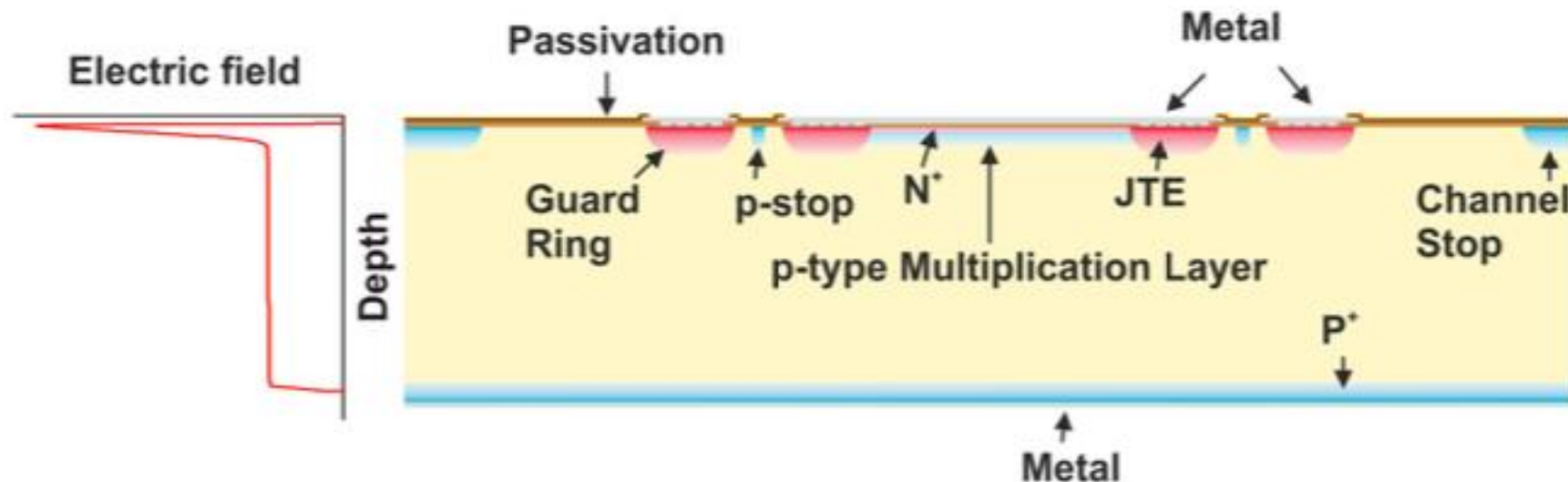
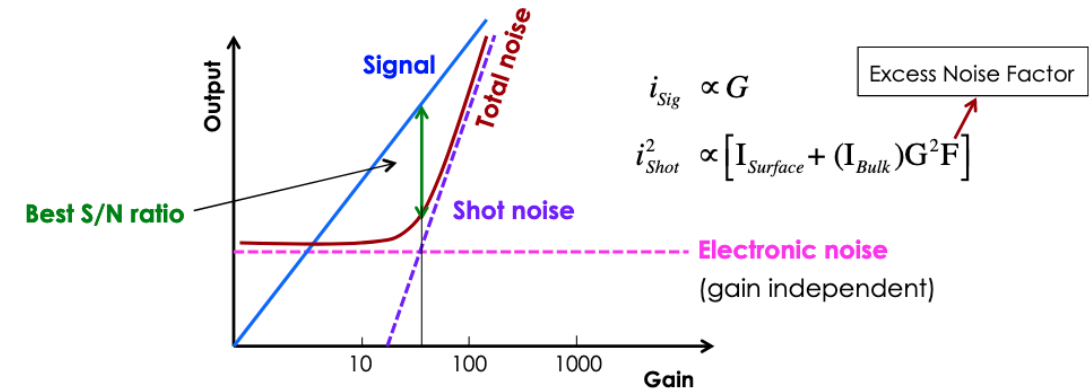

Low-Gain Avalanche Diode (LGAD). [8,11]

- When impurities are implanted, they extend vertically and also laterally during the diffusion process.
- The electric field at the edges of the planar junction can be bigger than in the planar junction and produce an undesired local breakdown on the junction edges, there are two possible solutions:
 - JTE: A deeper n-type diffusion at the edge.
 - FP: extension of the contact metal from the n+ over the field oxide. When the bias is applied, the depleted area extends, and the edge effect is mitigated.

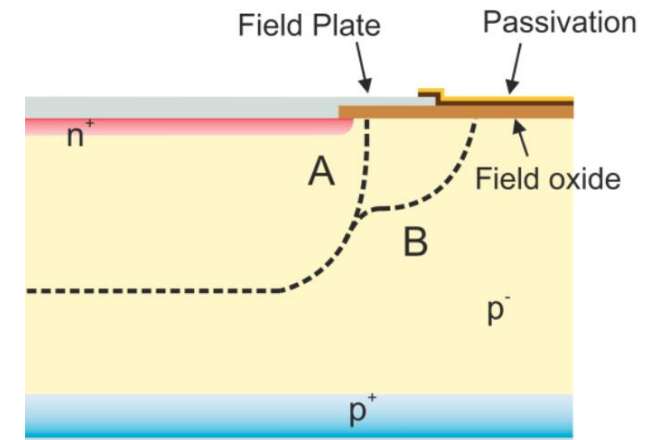
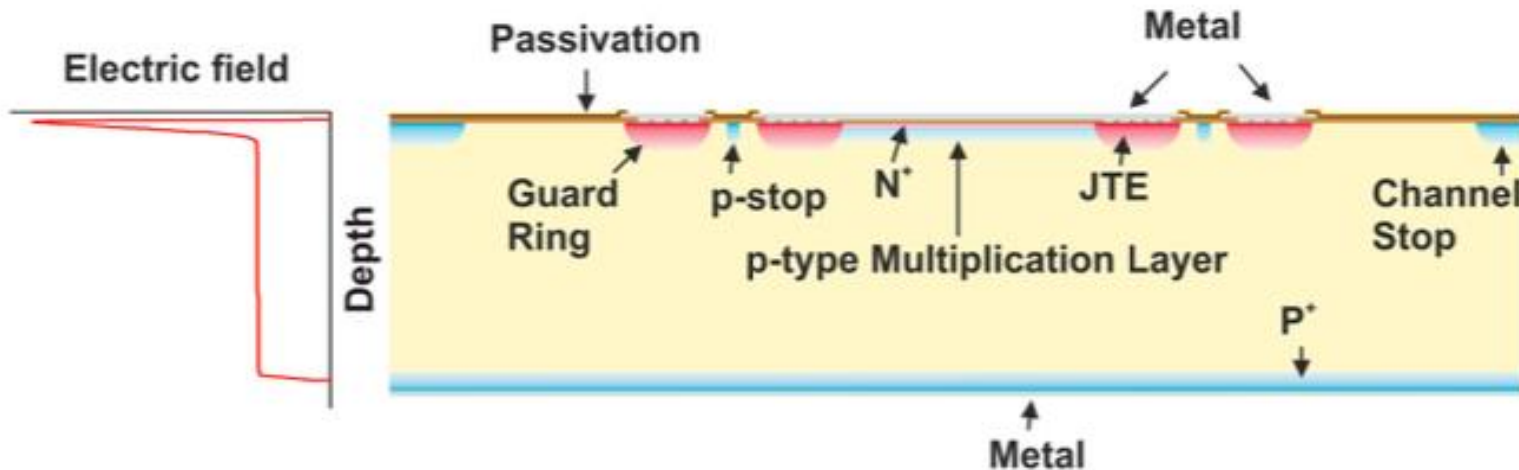

A: depleted area without FP.
B: with FP

Low-Gain Avalanche Diode (LGAD). [8,11]

- The Guard ring (GR) is another structure to protect from an early breakdown:
 - The bias voltage is applied so the GR collects the peripheric current of the device and reduces the thermal noise contribution
 - The distance between the GR and the junction needs to be calculated (TCAD) to have the best performance:
 - Too close: trigger early breakdown of the device
 - Too far: doesn't protect the junction breakdown

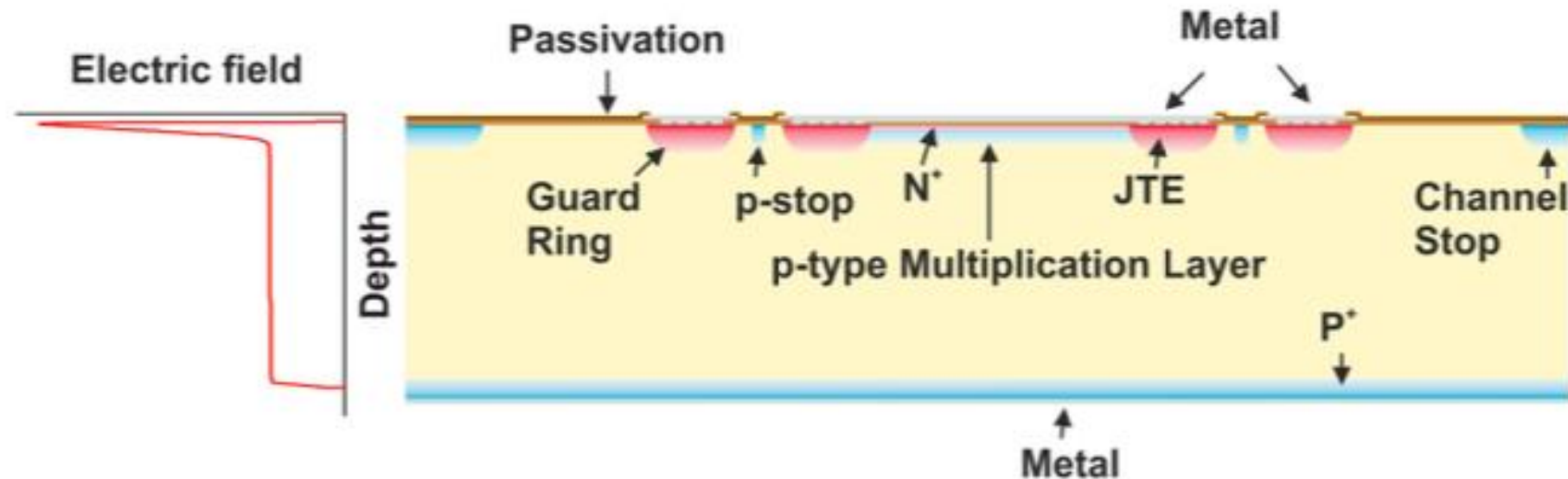

Radiation resistance of LGAD detectors. [8,11]

- Higher voltages are required after radiation damage to collect the same charge
- The gain layer is a highly doped P⁺⁺ -type layer.
- One of the radiation effects in silicon is the change on the doping concentration.
 - In LGADS, the major effect in their performance is the “acceptor removal” in the gain layer (Changes N_{eff}).
 - The higher is the acceptors concentration the lower is this effect
 - Thin gain layers are preferable (1-2 μm)

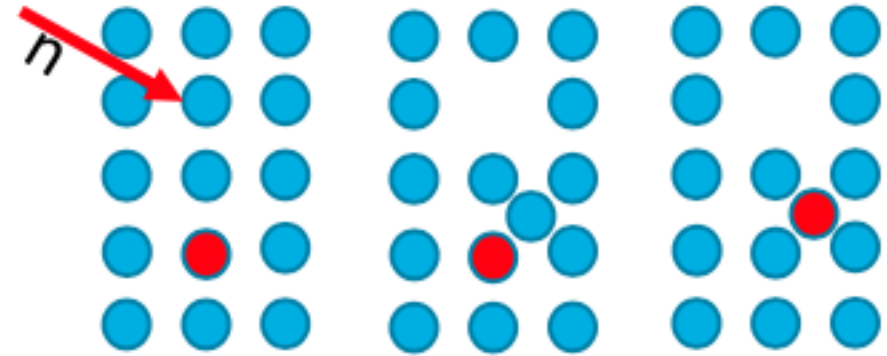

Impinging particle hits a silicon atom and displace the boron (dopant) becoming inactive (boron interstitial)

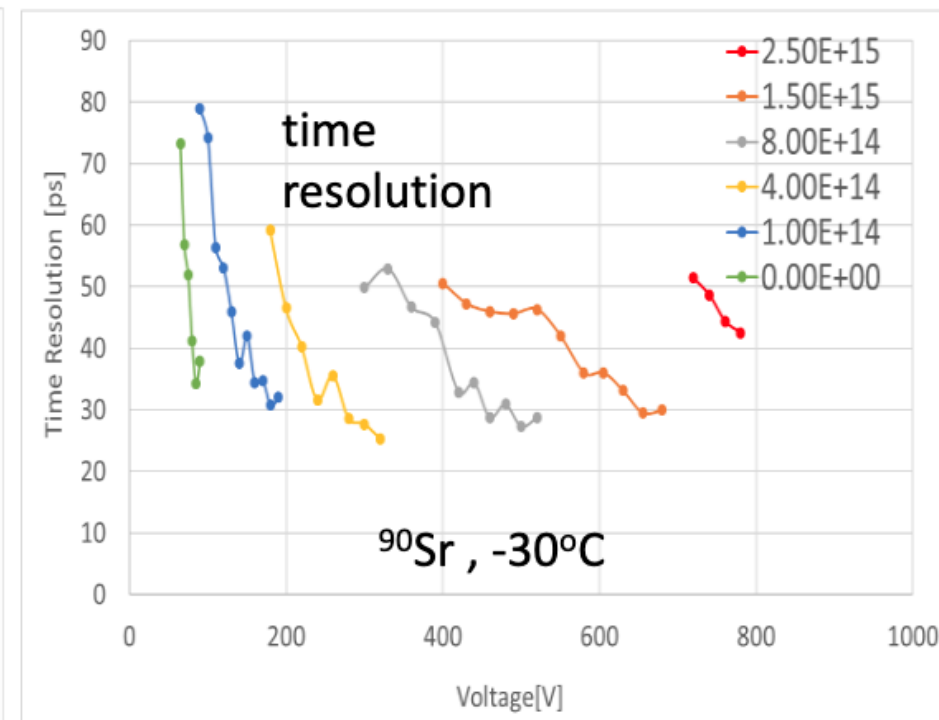
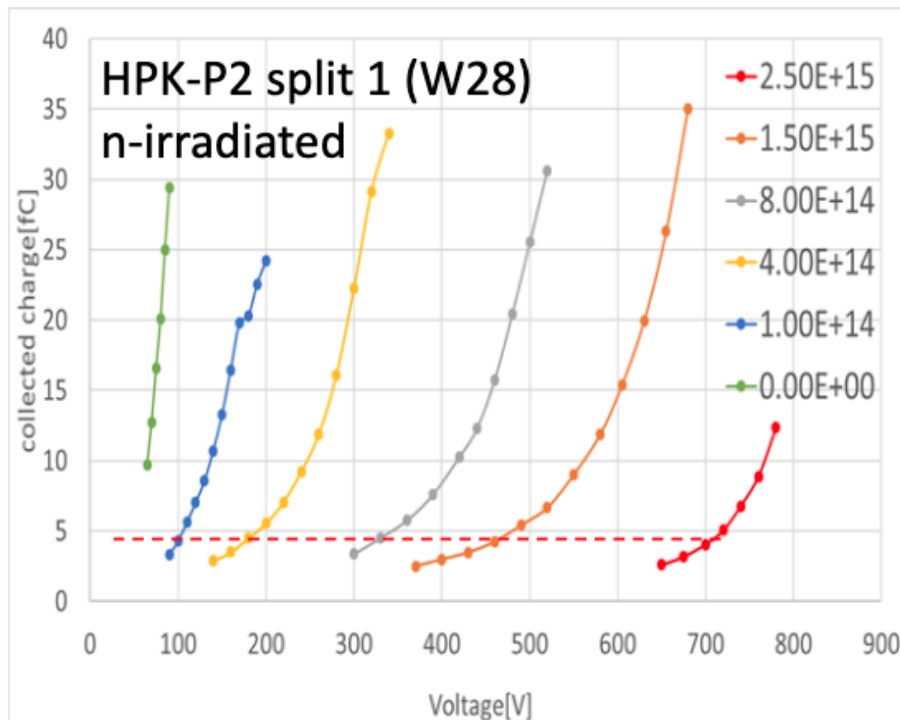

Radiation resistance of LGAD detectors. [8,11]

- The decrease of V_{gl} (gain layer depletion voltage) leads to the loss of gain/collected charge. Can be compensated by increasing the V_{bias} .
- Compensation by increasing the V_{bias} ends when the bulk multiplication is triggered “breakdown” (~800V)
- High voltages and especially high currents imply high power dissipation (energy loss in the form of heat) → thermal run away!!
- High Granularity Timing Detector (see later) can tolerate on average ~2 $\mu\text{A}/\text{pad}$ (1.3 x1.3 mm^2) before running into problems with thermal runaway (100 mW/cm^2)

Q4. Do you know what is the thermal runaway?

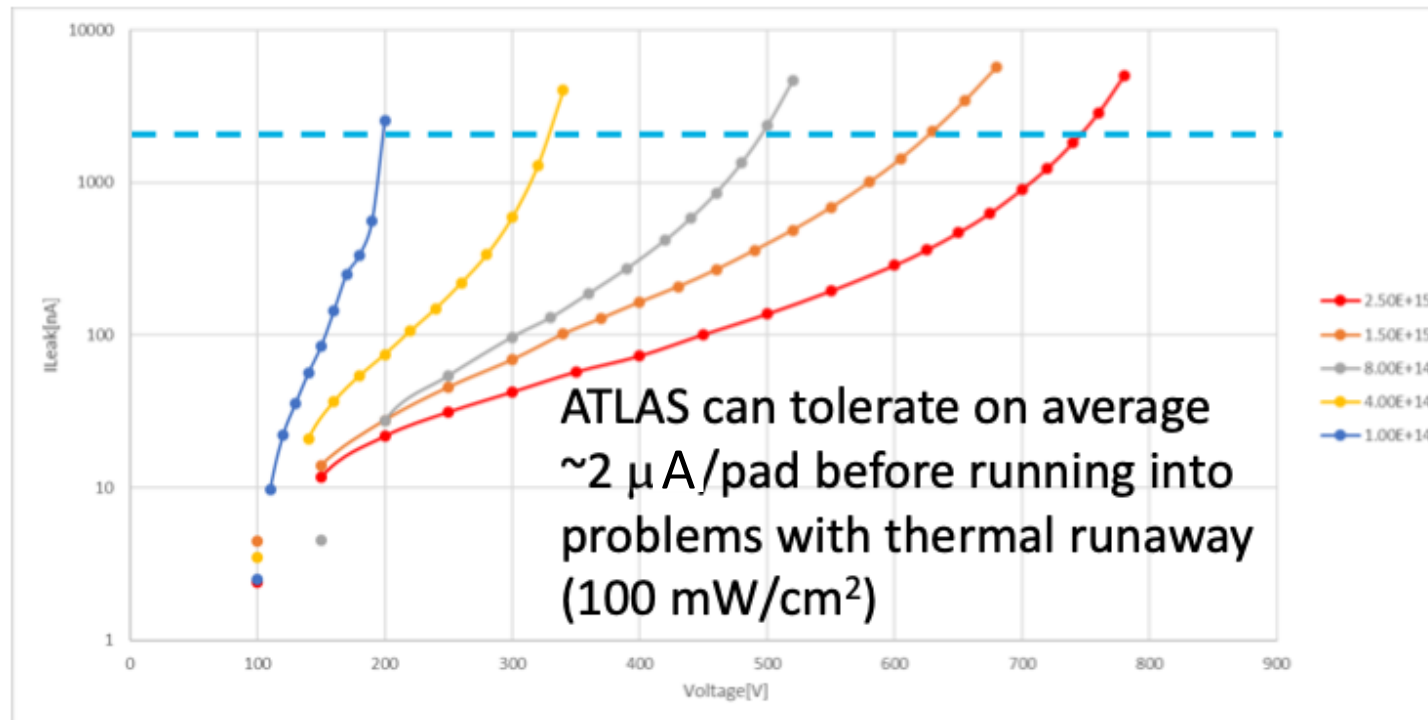

I_{leak} grows linearly with fluence in devices without amplification

Radiation resistance of LGAD detectors. [8,11]

- To increase the radiation resistance of LGADS:
 - Usual dopants used in the gain layer is Boron
 - **Carbon enrichment:**
 - Adding Carbon as an impurity to the gain layer has been proven effective to decrease the acceptor removal constant
 - carbon is trap for interstitial silicon atoms which are then not available for displacement of Boron -> hence smaller removal rate
 - Better performance after irradiation, lower voltages,

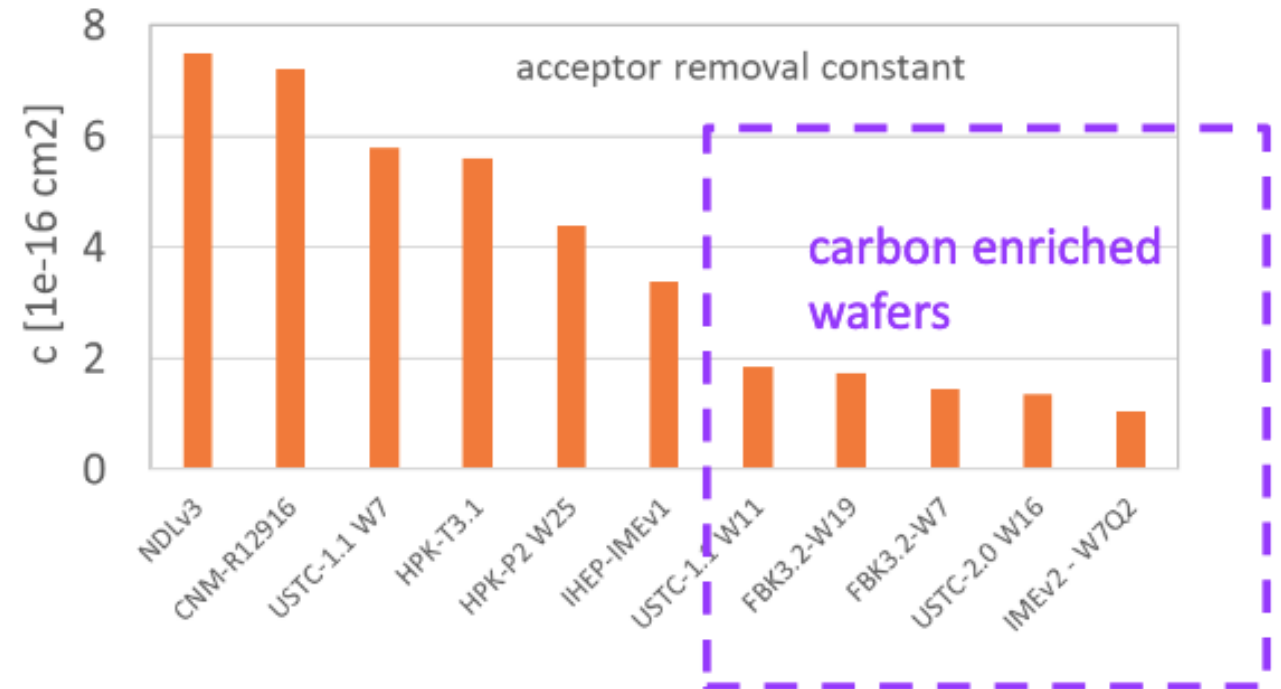

Radiation resistance of LGAD detectors. [8,11]

$$\phi = 2.5 \times 10^{15} \text{ n}_{\text{eq}}/\text{cm}^2$$

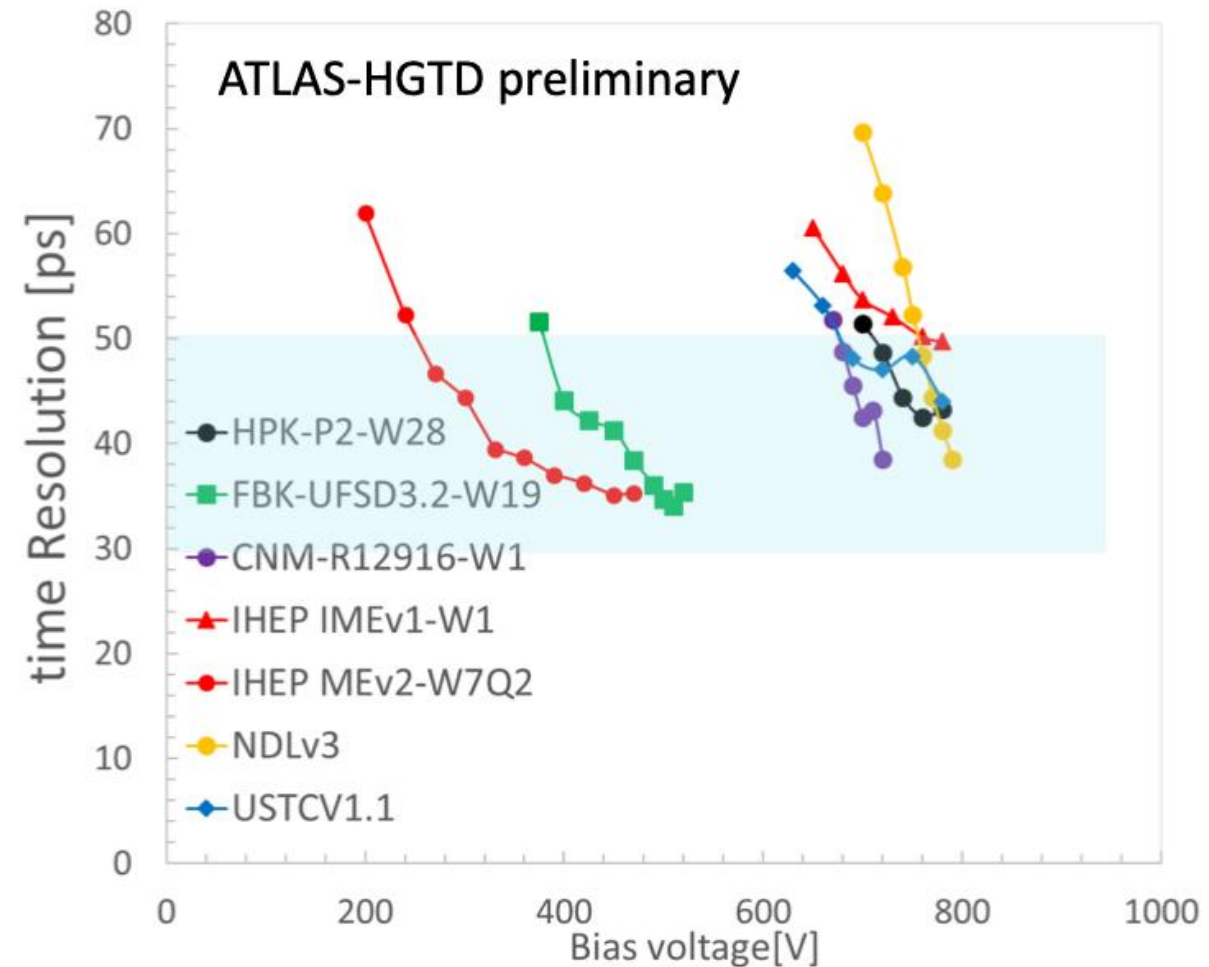
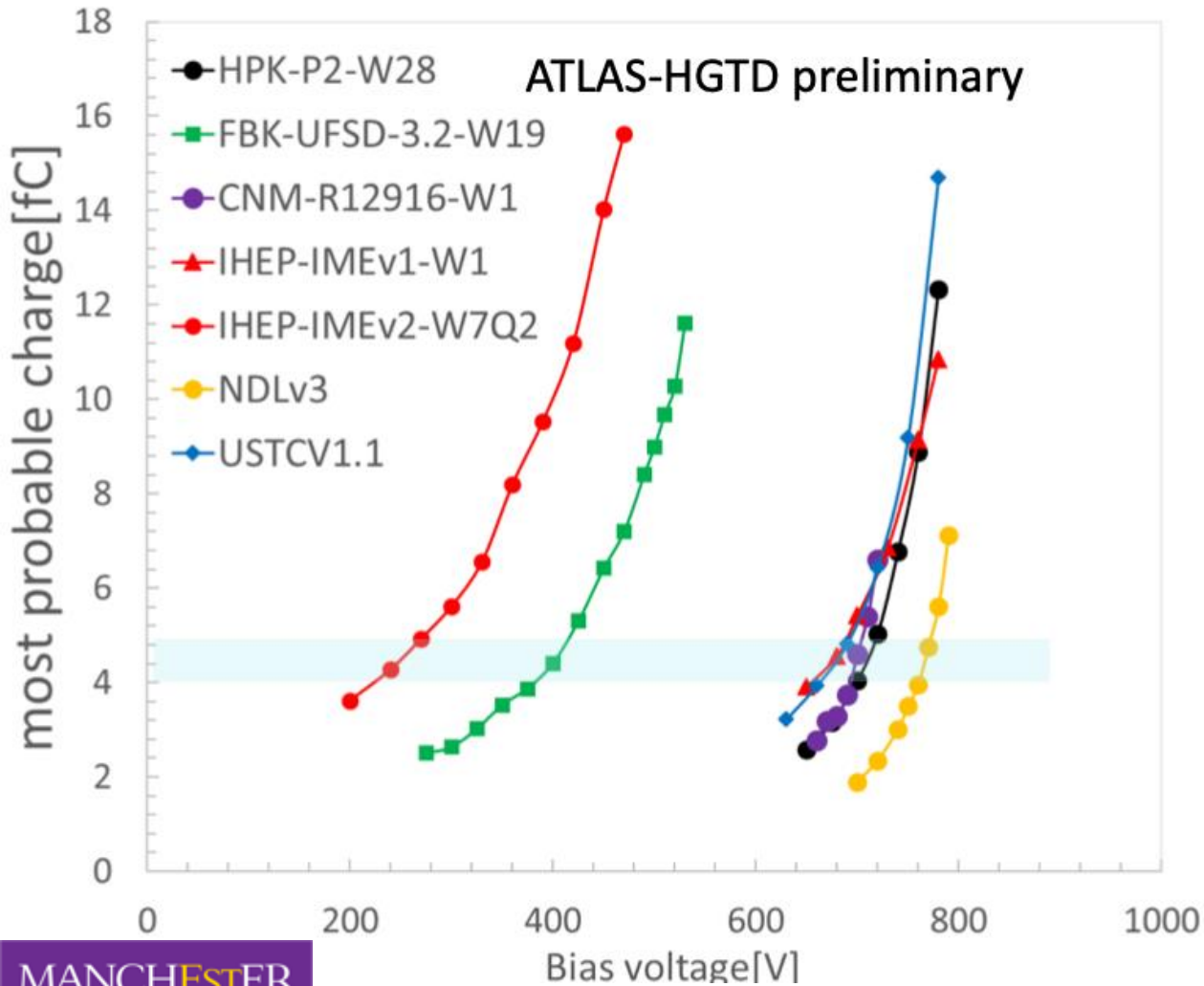

Radiation resistance of LGAD detectors. [8,11]

$$\phi = 2.5 \times 10^{15} \text{ n}_{\text{eq}}/\text{cm}^2$$

Carbon Enriched devices

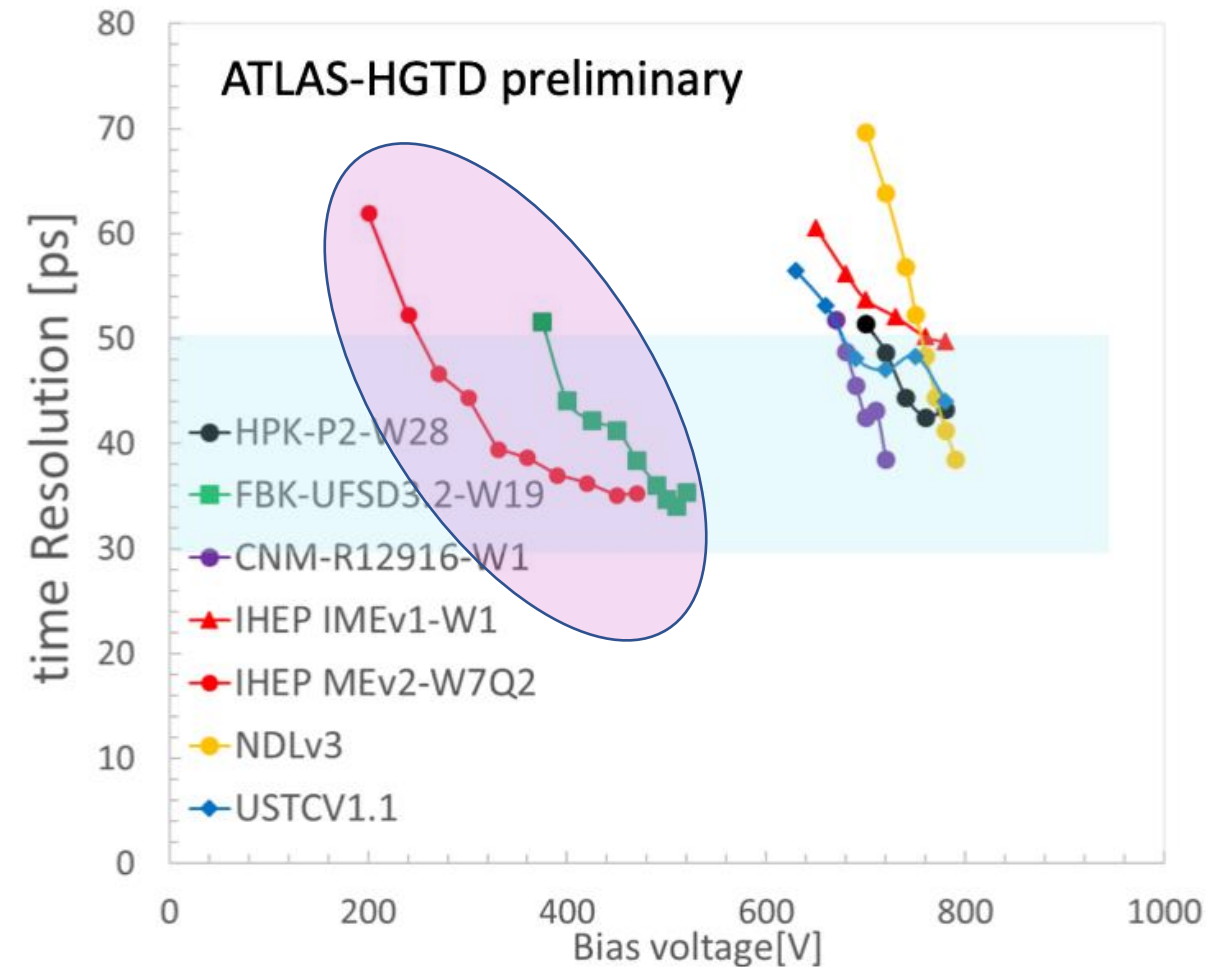
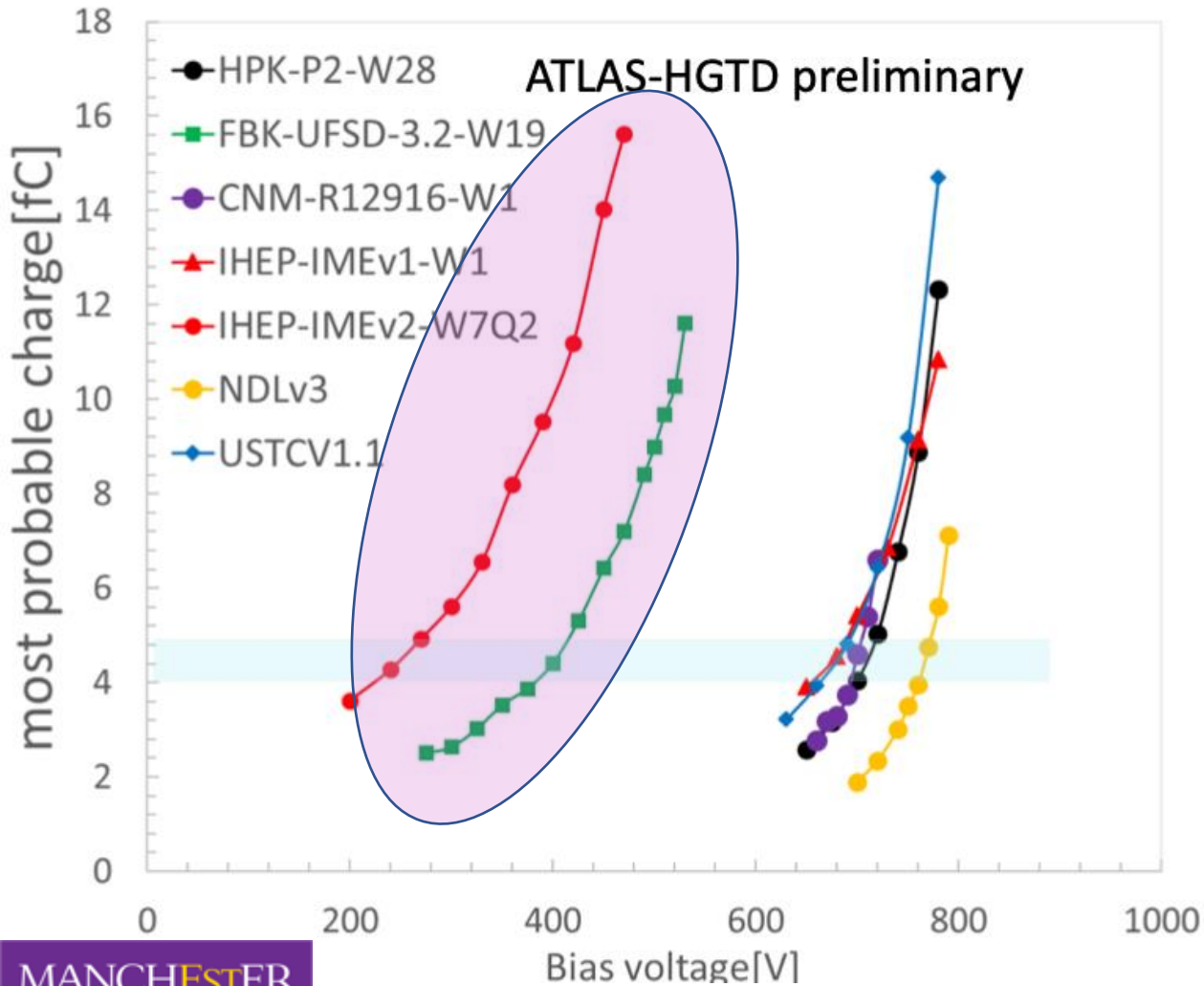

Segmentation in LGAD detectors [11,16]

- JTE allows for an efficient isolation of electrodes and segmentation
- The inter-pad region is effectively a non-active region (dead area)
- Reduced fill factor of LGADS
- The Inter-pad region needs to be sufficiently big to avoid that in case of a floating pad (bad connection) \rightarrow breakdown
- Inter-pad distances between 30-90 μm
- Reduction of GL doping and increase of bulk doping with radiation reduces effective inter-pad gap hence the fill factor increases!

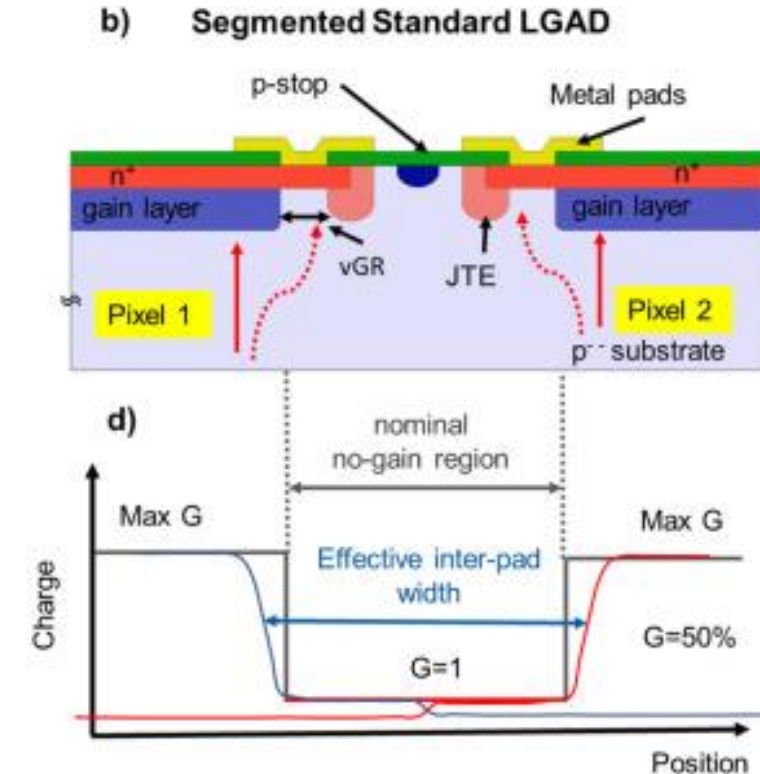
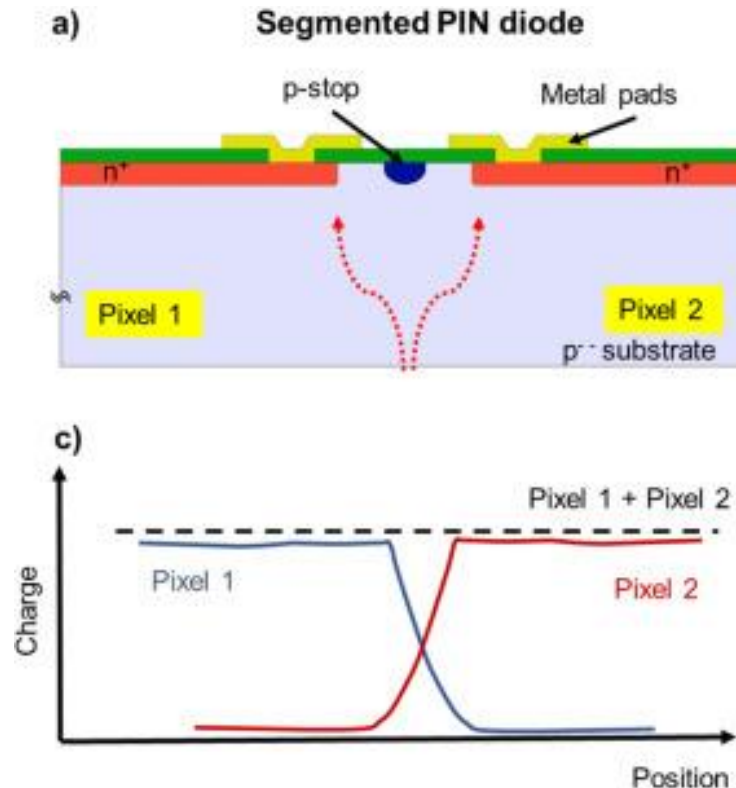

Q5. How would you increase the granularity and keep the performance in LGADSs?

Segmentation in LGAD detectors [11,16]

- Different LGAD segmentation strategies:
 - a) Standard. Inter-pad distance limited.
 - b) Inverted LGAD (double sided). The segmentation is not done on the junction and gain layer; it requires two sides processing and thick wafers (300 μm).
 - c) Silicon oxide trenches, that reduce the Inter-pad distance to few microns.
 - d) Resistive AC-coupling. The n^+ -layer and gain layer are not segmented, and the read-out segmentation is provided by metal pads that are AC-coupled to the resistive n^+ -layer via a thin dielectric layer.
 - The signal at the readout pads is mainly induced. After that, the charge carriers are collected at the front junction and they propagate laterally along the n^+ - layer, discharging to the ground. The signal is shared among multiple pads.

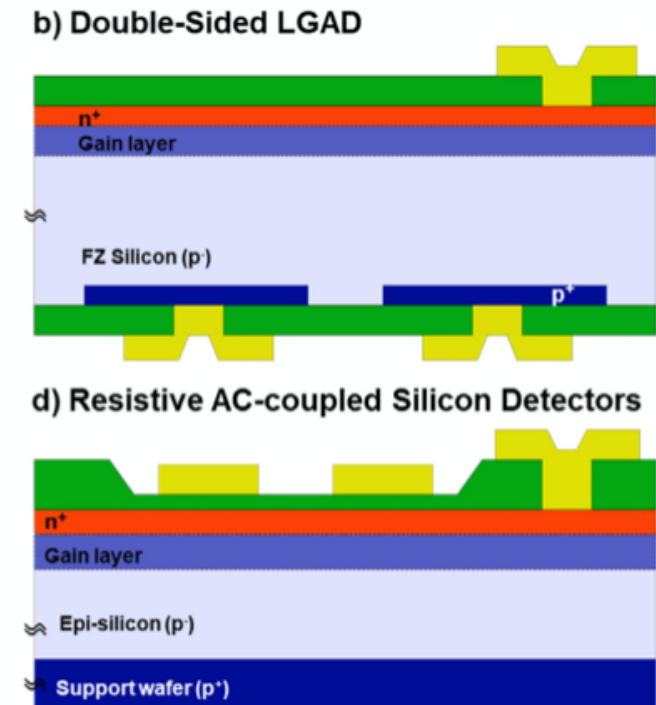
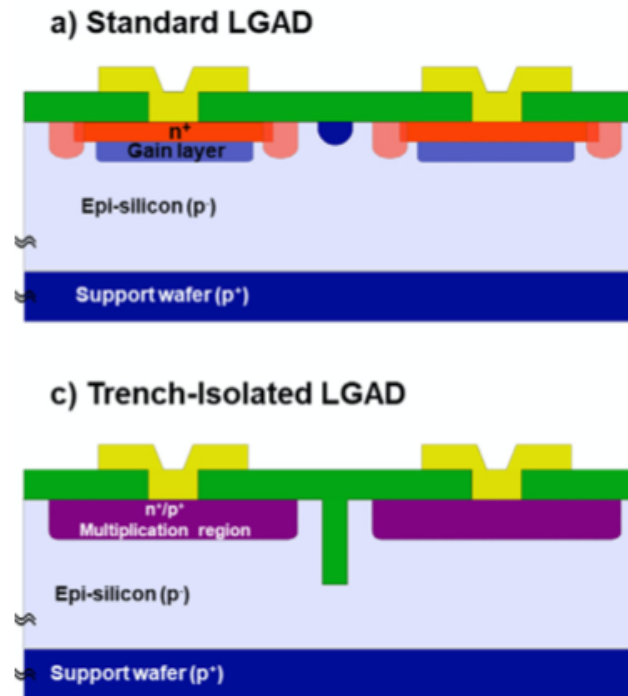

LGAD Single event Burnout [11]

- Most Charge collection measurements performed in the labs with ^{90}Sr sources and prototype sensors work well up to large bias voltages $>700\text{ V}$ (very high average fields $>14\text{ V/mm}$) and good enough performance. The measurements in the test beams were more problematic:
 - Sensors in test beams die with a typical burn mark pattern –“star shaped crater” at lower voltages than in lab ($\sim 100\text{V}$).
 - They were not specific to any producer (observed for HPK/CNM prototypes) or beam line (DESY/SPS test beams).
 - After a dedicated R&D task.
 - A single particle is responsible of the burnout
 - After it; the sensor is “in-short” and not operational
 - The event happens in different places along the sensor (no clear correlation with a “weak spot”)
 - It happens on thin sensors (35-50 μm) due to the average **E**:
 - $E < 11\text{ V}/\mu\text{m} \rightarrow$ safe region
 - $E \sim 11 - 12\text{ V}/\mu\text{m} \rightarrow$ danger region
 - $E > 12\text{ V}/\mu\text{m} \rightarrow$ SEB region
 - Practical solution, keep bias lower in function of the device thickness

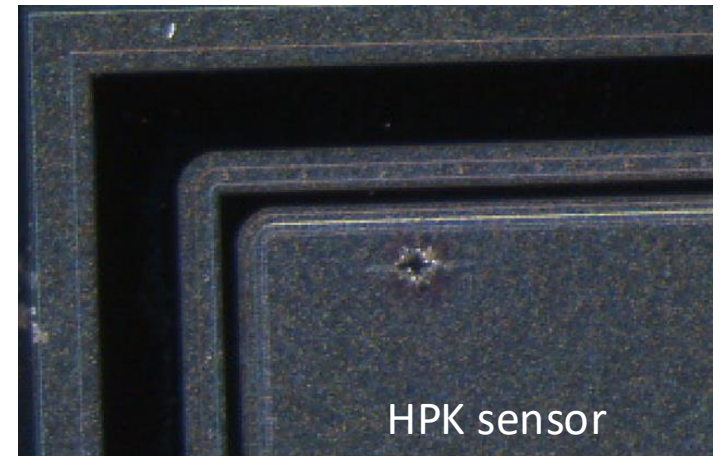
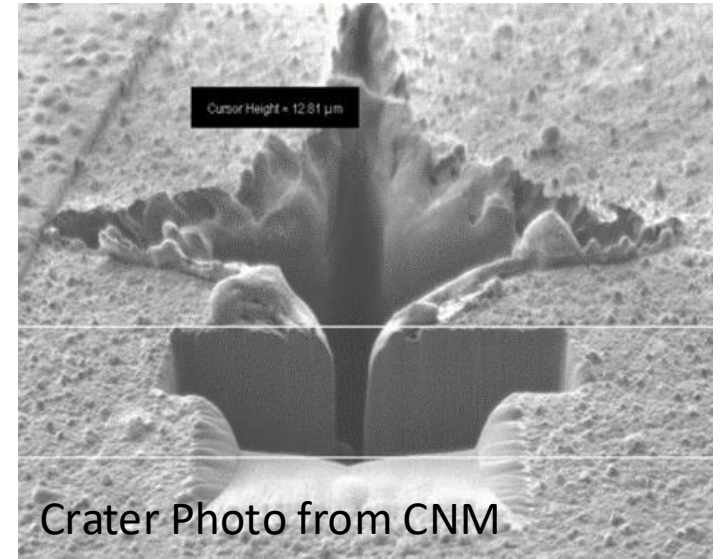

LGADs applications in collider experiments

- ATLAS- High Granularity Timing detector [17]

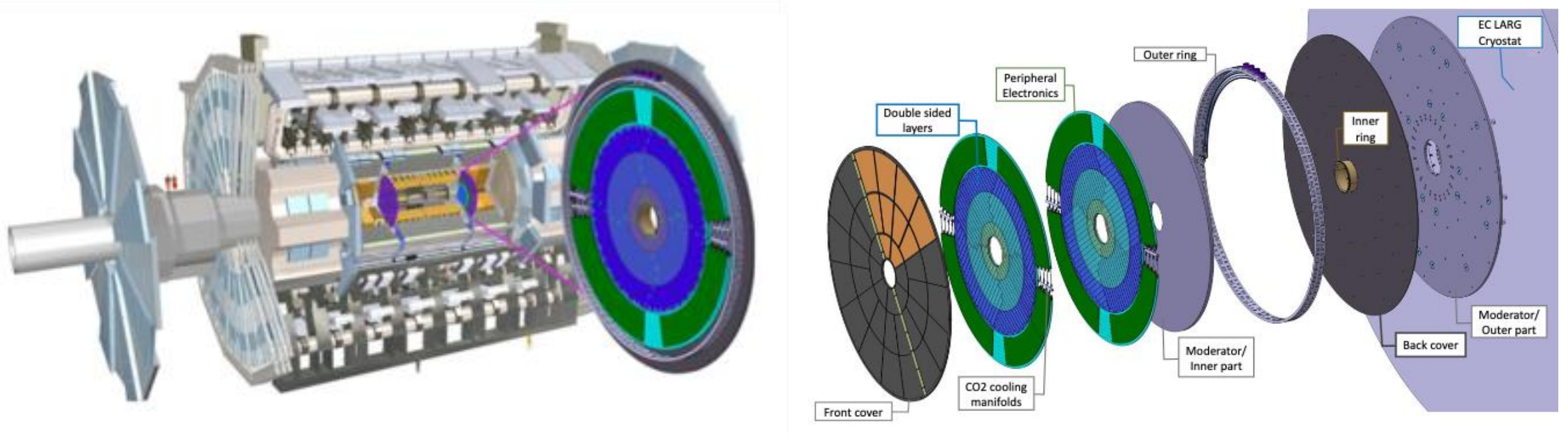

The various components are shown: hermetic vessel (front and rear covers, inner and outer rings), two instrumented double-sided layers (mounted in two cooling disks with sensors on the front and back of each cooling disk), two moderator pieces placed inside and outside the hermetic vessel (protect ITk and HGTD against the back-scattered neutrons that are produced by the end-cap calorimeters).

- $2.4 < |h| < 4$, $120 \text{ mm} < r < 640 \text{ mm}$, $z=350 \text{ cm}$
- 3.6 M channels operating at -30°C (6.4 m^2 of Si)

LGADs applications in collider experiments

- ATLAS- High Granularity Timing detector [17].
- The schematic drawing (right-top) shows the overlap between the modules on the front and back of the cooling disk. There is a sensor overlap of 20% for $r > 470$ mm, 54% for $230 \text{ mm} < r < 470$ mm and 70 % for $r < 230$ mm.
- At the bottom, an HGTD hybrid module with its read-out flex cable tail. The bare module, glued on the flex cable, is made of a $4 \times 2 \text{ cm}^2$ sensor with two bump bonded ASICs. The signal lines of the ASIC are wire bonded on one side of the module flex, while the bias voltage of the sensor is provided to the back-side of the sensor through a hole in the module flex.
- Each bare module contains 450 pads (15×30).
 - Pad: $1.3 \times 1.3 \text{ mm}^2$.
 - 2 ASICs $20 \times 22 \text{ mm}^2$.

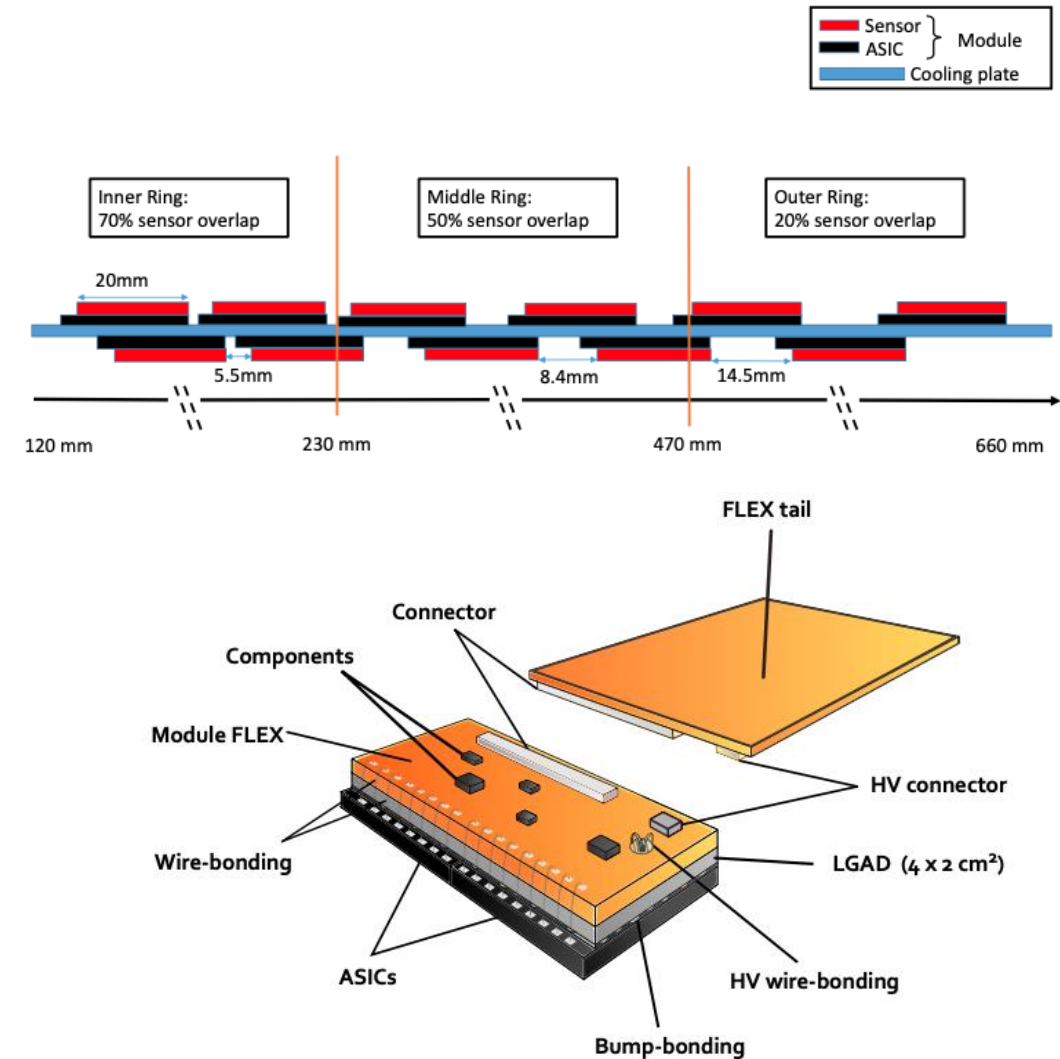

LGADs applications in collider experiments

- MTD: “A MIP Timing Detector for the CMS Phase-2 Upgrade” [18]

- Endcap Timing Layer. ETL → LGAD detectors
 - $1.6 < |\eta| < 3$, $315 \text{ mm} < r < 1200 \text{ mm}$
 - 8.5 M channels (14 m² of Si)
- Barrel Timing Layer. BTL → LYSO bars +SiPM

BTL: LYSO bars + SiPM readout:

- TK / ECAL interface: $|\eta| < 1.45$
- Inner radius: 1148 mm (40 mm thick)
- Length: $\pm 2.6 \text{ m}$ along z
- Surface $\sim 38 \text{ m}^2$; 332k channels
- Fluence at 4 ab^{-1} : $2 \times 10^{14} n_{\text{eq}}/\text{cm}^2$

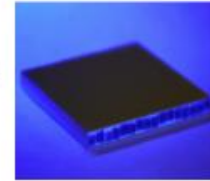

ETL: Si with internal gain (LGAD):

- On the CE nose: $1.6 < |\eta| < 3.0$
- Radius: $315 < R < 1200 \text{ mm}$
- Position in z: $\pm 3.0 \text{ m}$ (45 mm thick)
- Surface $\sim 14 \text{ m}^2$; $\sim 8.5 \text{ M}$ channels
- Fluence at 4 ab^{-1} : up to $2 \times 10^{15} n_{\text{eq}}/\text{cm}^2$

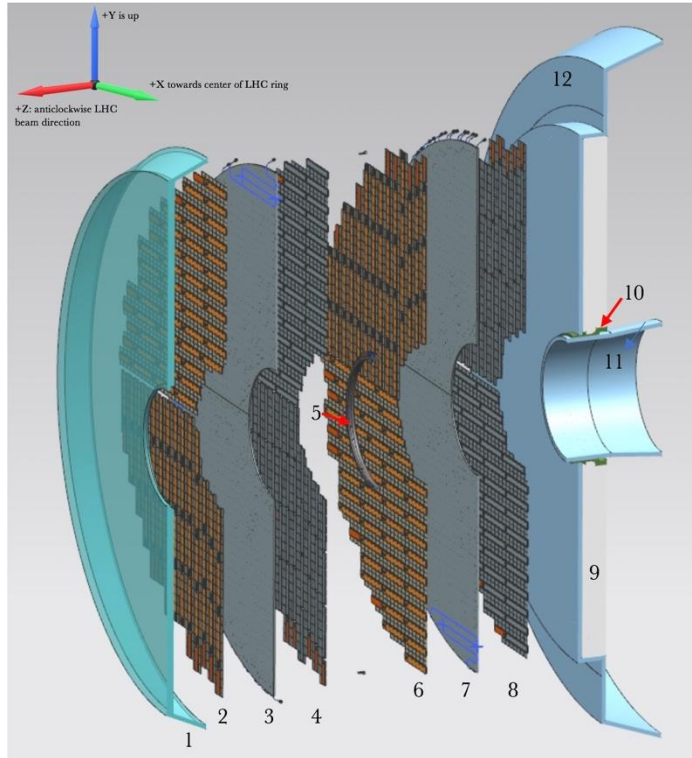
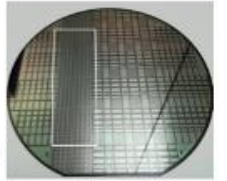

- 1: ETL Thermal Screen
- 2: Disk 1, Face 1
- 3: Disk 1 Support Plate
- 4: Disk 1, Face 2
- 5: ETL Mounting Bracket
- 6: Disk 2, Face 1
- 7: Disk 2 Support Plate
- 8: Disk 2, Face 2
- 9: HGCal Neutron Moderator
- 10: ETL Support Cone
- 11: Support cone insulation
- 12: HGCal Thermal Screen

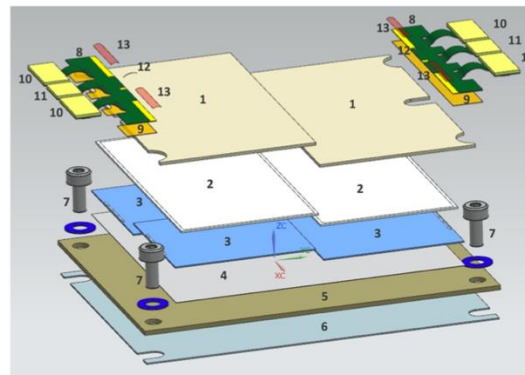
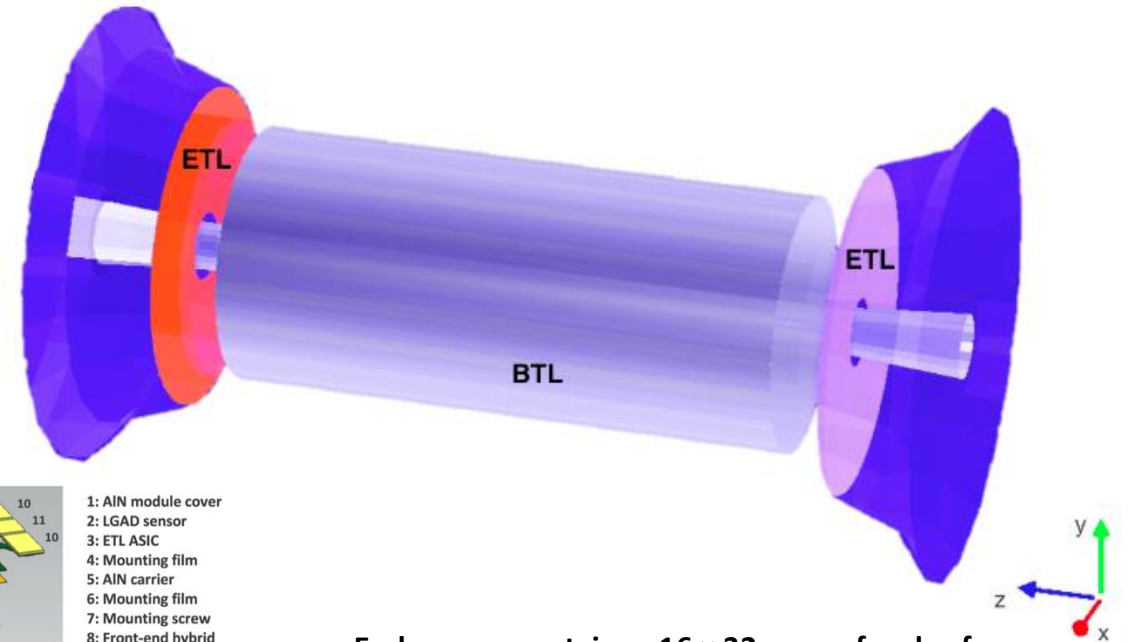

- 1: AlN module cover
- 2: LGAD sensor
- 3: ETL ASIC
- 4: Mounting film
- 5: AlN carrier
- 6: Mounting film
- 7: Mounting screw
- 8: Front-end hybrid
- 9: Adhesive film
- 10: Readout connector
- 11: High voltage connector
- 12: LGAD bias voltage wirebond
- 13: ETROC wirebonds

Each sensor contains a 16×32 array of pads of size $1.3 \times 1.3 \text{ mm}^2$. With the guard ring structures and bias ring, the dimensions of the sensor are $21.2 \times 42.0 \text{ mm}^2$.

Requirements for timing detectors in collider experiments

- $\sigma_t < 50$ ps for CMS and ATLAS to maintain their physics motivation:
 - Both together sensors + electronics
- Keep the optimal performance after significant radiation damage:
 - CMS:TID ~ 1 MGy, $\phi = 1.7 \times 10^{15}$ n_{eq}/cm^2 .
 - ATLAS: TID ~ 2.2 MGy, $\phi = 6 \times 10^{15}$ $n_{eq}/cm^2 \rightarrow$ **REPLACEMENTS foreseen** Q6: Why?
- Low occupancy allowed: $<10\%$ (ATLAS). $<2\%$ (CMS) to ensure a good hit efficiency and position resolution
- Compactness of the module assemblies
- Timing detectors require excellent time resolution on top of tracking efficiency and low noise occupancy

LGADs applications outside of HEP

- Beam monitoring on charged particles therapy [6]:
 - Gas detectors used now are affected by magnetic fields
 - Preliminary results from test of 50 μm thick LGAD silicon sensors segmented in strips show that :
 - the number of particles of a therapeutic beam can be measured with a maximum error of 1% up to a flux of more than 10^8 p/(cm^2s), limited by pile-up effects at higher fluxes.
 - fast online measurement of the beam energy for each spot can be obtained with the required clinical accuracy with time-of-flight techniques exploiting the high time resolution of the LGAD technology
 - LGADs need some development:
 - Segmentation in small pixels to cope with the fluxes of therapeutic beams
 - A high number of channels is required for the electronics, that must be bump-bonded to the sensor pads
 - The total material thickness must be kept low enough to avoid significant beam perturbations.
 - Radiation resistance
- As the field of medical physics is currently moving towards increasing the amount of radiation delivered per unit of time with the development of initiatives like FLASH radiotherapy linear accelerators, the introduction of fast detectors becomes important: LGADs represent a promising option for beam monitoring and dosimetry as they combine excellent spatial and temporal precision

Curiosity: Amplification without doping?

- The Silicon Electron Multiplier Sensor . SiEM. [19]
 - It achieves the amplification without doping
 - High E is achieved by 'geometry':
 - 50 μm depleted area \rightarrow 1
 - Amplification area. Silicon pillars \rightarrow 2
 - two metallic electrodes, separated by a dielectric are buried in between the pillars.
 - Simulation studies are ongoing to optimise the geometry
 - Fabrication process will need to be decided, optimised and tested (Deep Reactive Ion Etching).

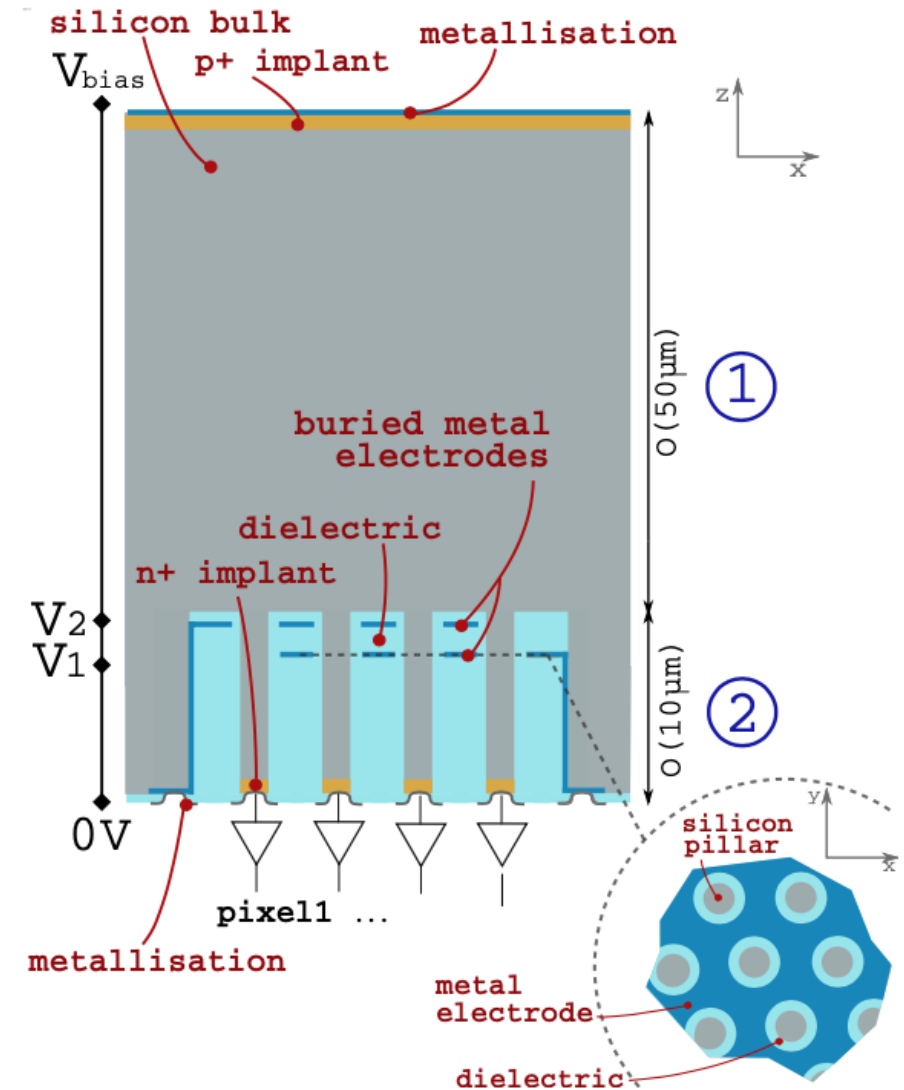

Questions

Discussion

- What do you think are the limitations (today) if any on LGADs?
- Where would you use them in future collider experiments? Why?

Feedback Please!

References

- [1] <https://hilumilhc.web.cern.ch/>
- [2] P. Vanlaer PhD Thesis: [“Contribution to the study of the central tracking system of the CMS detector, at the future proton collider LHC”](#), 1999
- [3] L. Gray [“4 Dimensional trackers”](#) contribution to Connecting the Dots workshop 2017
- [4] A. Vignati et al. [Innovative thin silicon detectors for monitoring of therapeutic proton beams: preliminary beam tests](#), 2022
- [5] T. Isidori et al. [Performance of a low gain avalanche detector in a medical linac and characterisation of the beam profile](#), 2021
- [6] L. Bottura et al. [Delivery, Beam and Range Monitoring in Particle Therapy in a Highly Innovative Integrated Design](#), 2020
- [7] F. Ulrich-Pur et al. [Feasibility study of a proton CT system based on 4D-tracking and residual energy determination via time-of-flight](#), 2022
- [8] M. Carulla Areste PhD Thesis : [“Thin LGAD timing detectors for the ATLAS experiment”](#), 2019
- [9] S. Ugobono PhD Thesis: “Characterisation and optimisation of Radiation-Tolerant silicon sensors with intrinsic gain”, 2018
- [10] K. Banerjee. [“What is Avalanche Photodiode? Its 5+ Important uses and characteristics”](#)
- [11] G. Kramberger. [“LGADs for timing detectors at HL-LHC”](#). CERN Detector seminar, 2021
- [12] Tae Yong Song et al. [“Characterization of two deep-diffusion avalanche photodiode array prototypes with different optical coatings,”](#) in IEEE Transactions on Nuclear Science, vol. 51, no. 5, pp. 2279-2283, Oct. 2004.
- [13] M. Centis Vignali et al. [“Deep diffused APDs for charged particle timing applications: Performance after neutron irradiation,”](#) NIM A 949 (2020) 162930.
- [14] F. Zappa et al. [“Principles and features of single-photon avalanche diode arrays”](#), Sensors and Actuators A: Physical, 140-1,2007,103.
- [15] B. Dolgoshein. [“The silicon photomultipliers in particle physics: possibilities and limitations”](#). Innovative Detectors for Supercolliders workshop. 2003.
- [16] G. Paternoster et al. [“Novel strategies for fine-segmented Low Gain Avalanche Diodes”](#), NIM A 987 (2021) 164840.
- [17] ATLAS. [“Technical Design Report: A High-Granularity Timing Detector for the ATLAS Phase-II Upgrade”](#), 2020.
- [18] CMS. [“Technical Design Report: A MIP Timing Detector for the CMS Phase-2 Upgrade”](#), 2019.
- [19] Marius Maehlum et al. [“ The Silicon Multiplier Sensor”](#) . arXiv:2203.01036 ,2022.