

# Device Structures: planar and 3D

***Advanced UK Instrumentation Training 2026***

*Francisca Muñoz Sánchez*

*University of Manchester*

*19<sup>th</sup> May 2026*

# Contents

- Semiconductor sensors basics
- Radiation damage
- Position Resolution: Strips and pixels
- Device structures: Planar and 3D
- Hybrid detectors:
  - Wire-bonding
  - Bump-bonding
- Applications on collider experiments
- Micro-strips detectors developments
  - ITk example
- Pixel detectors developments
  - ITk example
- Future Challenges for hybrid detectors
- Other semiconductors
- Some 'exotic' ideas

# Semiconductor sensors basics [1]

More details on lectures on  
Band theory 1 and 2

## Doping in Silicon:

- Impurities are introduced to displace Si- Fermi level
  - Donors: dopants adding free e in the conduction band (group V, Phosphorus)
  - Acceptors: dopants adding holes in the valence band (group III, Boron)
- N – type: excess of  $e^-$  in the conductive band
- P – type: excess of  $h^+$  in the valence band

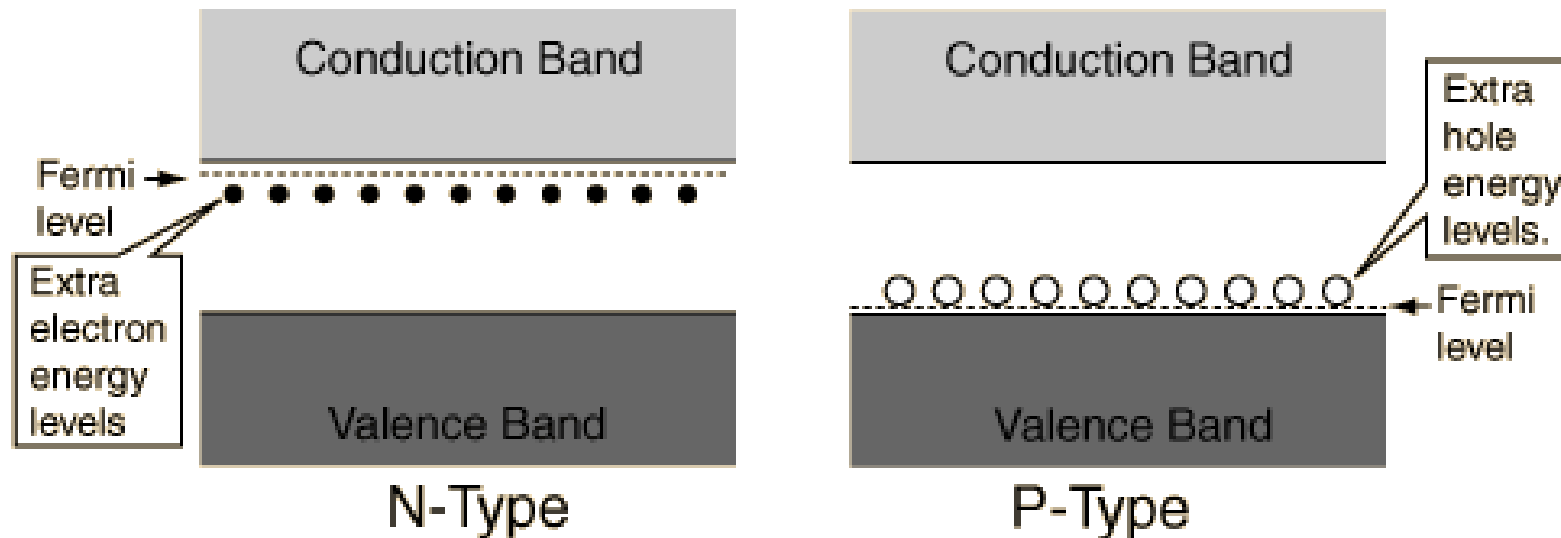

# Semiconductor sensors basics [1]

## PN- junction:

- The gradient of  $e^-$  and  $h^+$  densities causes diffusion, and carriers recombine until the diffusion stops
- An electric field is created because now part of the p-type has a net negative charge, and the opposite occurs to the n- type

$$V_{bi} = \frac{e_0}{2\epsilon_{Si}\epsilon_0} (N_D X_n^2 + N_A X_p^2)$$

*Intrinsic pn- junction built-in potential (~0.5-1V)*

*Applying electrical neutrality*

$$N_A X_p = N_D X_n$$

$$|N_{eff}| = N_D - N_A$$

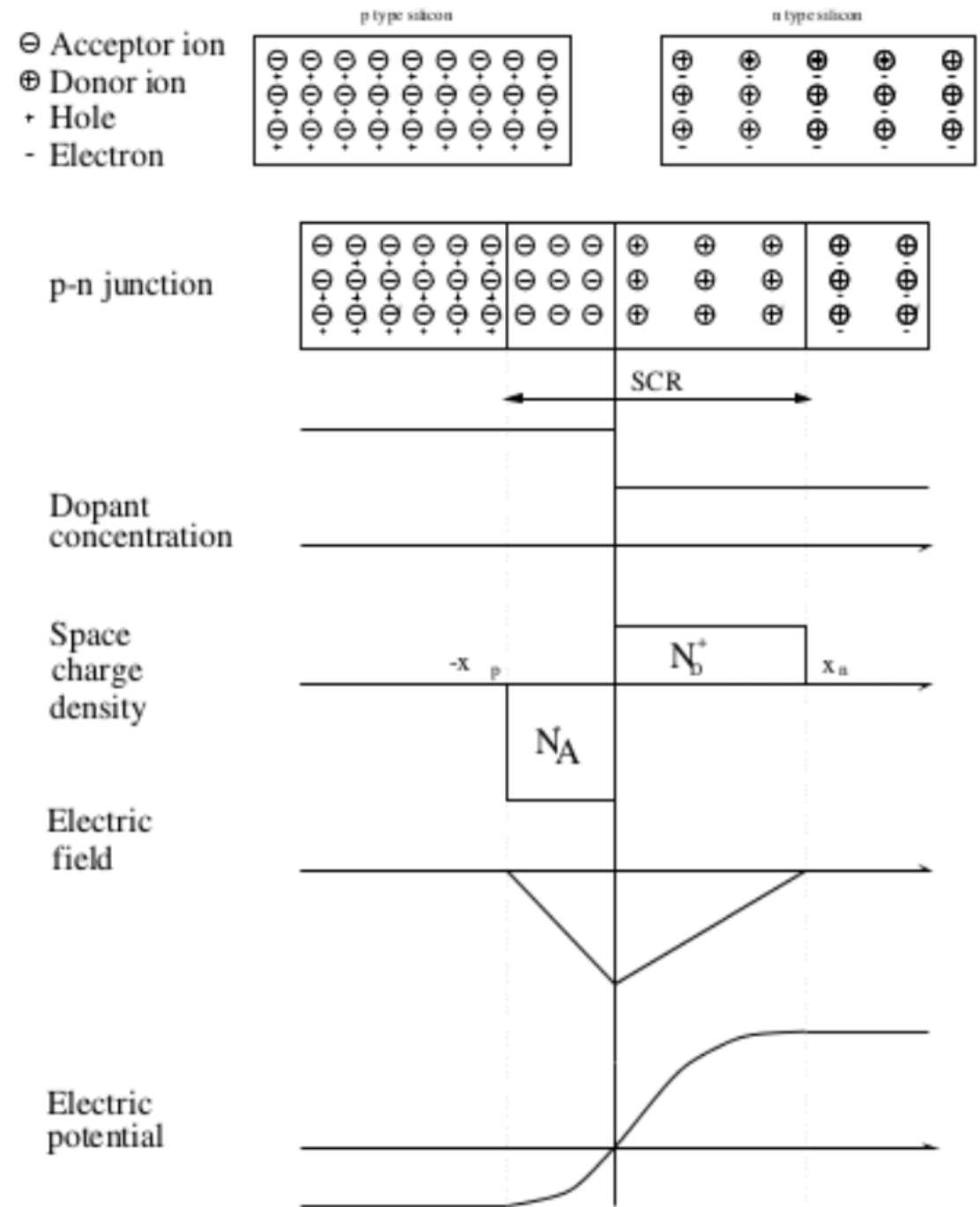

# Semiconductor sensors basics [1]

- The area created is called Depletion area and is an area with low carriers' concentration  $\sim 100$  carriers/cm<sup>3</sup>, while in p or n type  $\sim 10^{10}$  carriers/cm<sup>3</sup>.

Depletion width

$$W = \sqrt{\frac{2\epsilon_{Si}\epsilon_0}{e_0} \frac{V_{bi}}{|N_{eff}|}}$$

- To extend that area an external bias ( $V_{bias}$ ) can be added with the same polarity than the  $V_{bi}$

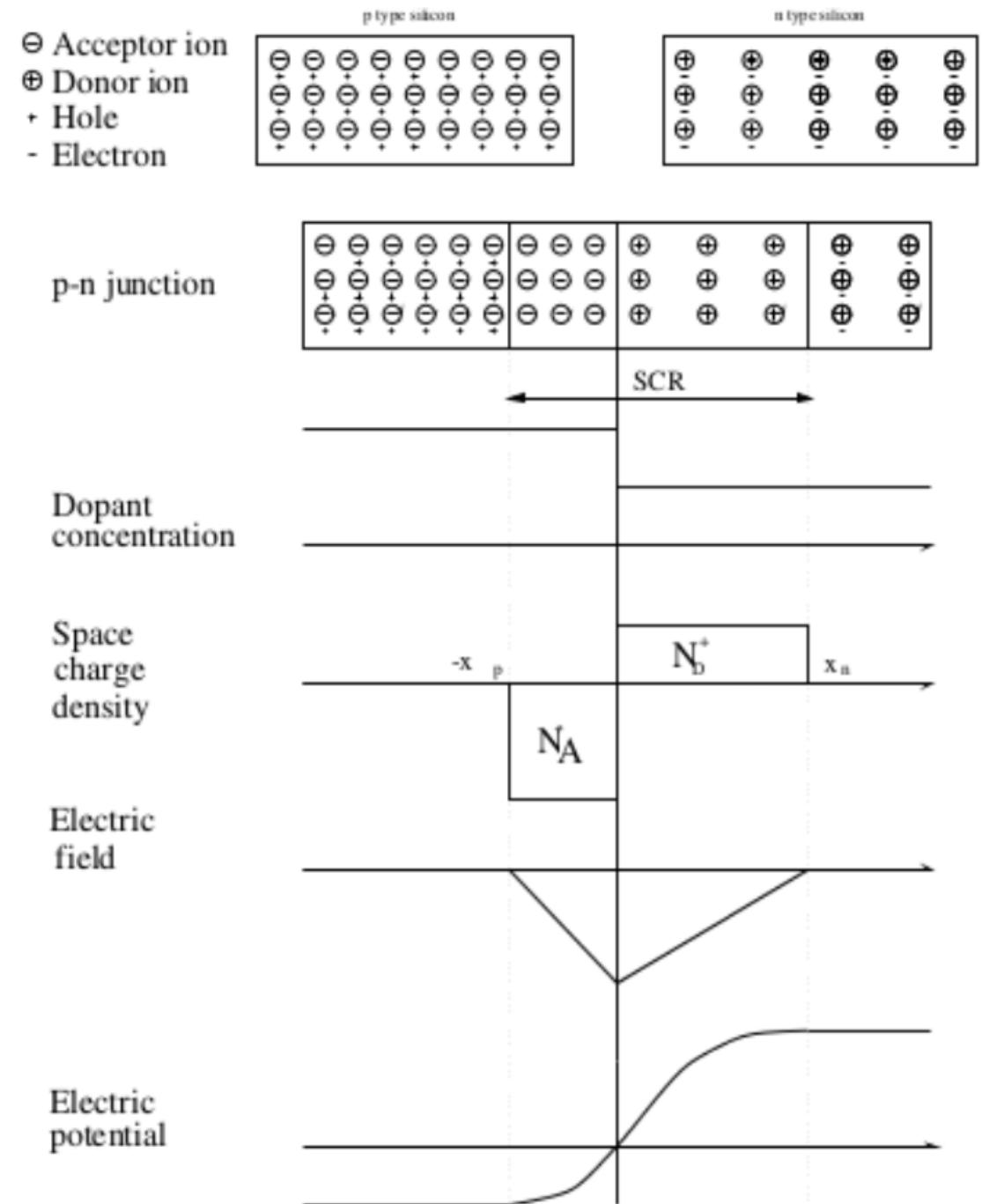

# Semiconductor sensors basics [2]

- Silicon diode:
  - PN-junction
  - Ohmic contact to avoid a 'Schottky contact'
  - External voltage ( $V_{bias}$ ) on top of the built-in voltage to make depleted area bigger ( $V_{bias} \gg V_{bi}$ )

$$W(V_{bias}) = \sqrt{\frac{2\epsilon_{Si}\epsilon_0}{e_0 \cdot |N_{eff}|} V_{bias}}$$

- The Voltage needed to fully deplete the device is called full depletion voltage ( $D$ =distance between electrodes):

$$V_{FD} = \frac{e_0 N_{eff} D^2}{2\epsilon_{Si}\epsilon_0} (\propto D^2)$$

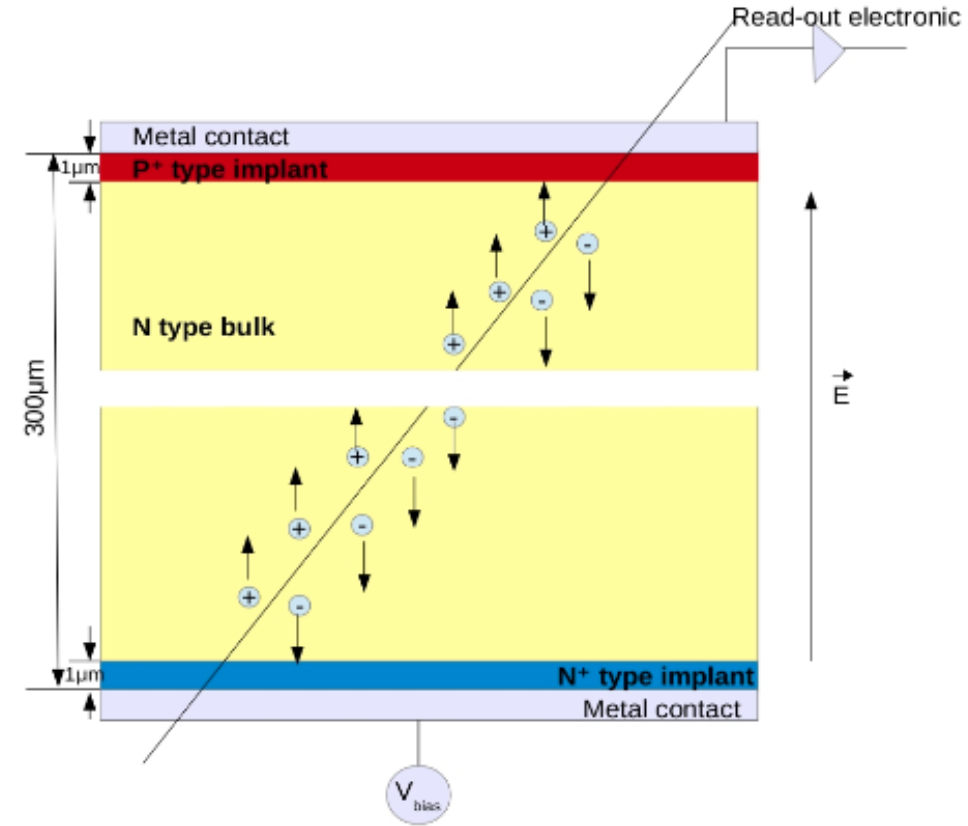

Q1: Why do we choose Si? Can we build the same devices with other semiconductors?  
Which ones for what applications?

# Semiconductor sensors basics [2]

- For practical reasons, the most used magnitude is the capacitance:

$$\frac{1}{C^2} \propto \begin{cases} V_{bias} & \text{if } V_{bias} < V_{FD} \\ D^2 & \text{if } V_{bias} \geq V_{FD} \end{cases}$$

- Signal generation:
  - Free carriers in movement (Ramo's theorem):
    - Thermal generation (energy gap small)
    - Electromagnetic radiation ( $\gamma$ - absorption)
    - Charged particles. Bethe-Bloch Formula  $\rightarrow$  MIP, 89 e/um
  - Amplifier + ADC ( analogue to digital converter)
- We can know that a particle has gone through our device if it produces a signal

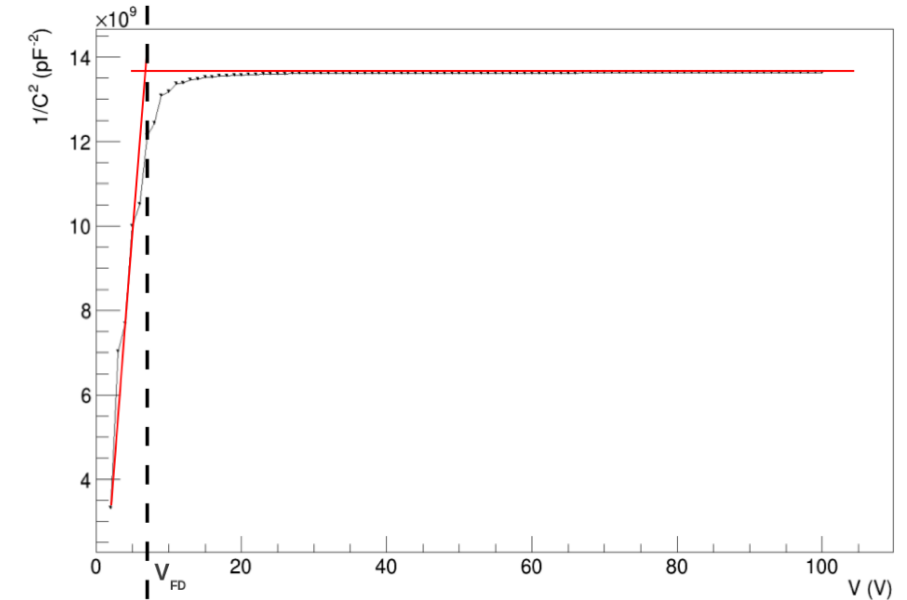

Q1: Why do we choose Si? Can we build the same devices with other semiconductors? Which ones for what applications?

# Semiconductor sensors basics. Noise [2]

- The position resolution is determined by the signal-to-noise ratio. Minimising the noise is always beneficial.

- **Noise due to have carriers in movement (I) :**

- Thermal noise: noise due to the thermal fluctuations of the carriers:  $i_n^2 = \frac{4kT}{R}$

- Low frequency noise: inversely proportional to the frequency. Carriers get trapped in crystal defects and then released with a time constant  $\tau$  :

$$i_n^2 \propto \frac{1}{f}$$

- Shot noise: is a consequence of the carriers charge discreteness, and it generates time dependent fluctuations in the current:

$$i_n^2 = 2eI$$

**In general, the sensor leakage current will contribute with shot noise, resistors with thermal noise and the input transistor contributes with two components, shot and low frequency noise.**

- Any noise before the amplifying chain, will get amplified together with the signal.

# Semiconductor sensors basics. Noise [2]

- The total noise of a detector system measured as ENC (Equivalent Noise Charge) at the input of the amplifier is given by adding noises due to the leakage current  $ENC_i$ , parallel resistors as thermal noise  $ENC_{th}$ , resistors in series in the circuit  $ENC_S$  and the noise due to the preamplifier frequency response  $ENC_{pa}$

$$ENC_{tot}^2 = ENC_i^2 + ENC_{th}^2 + ENC_S^2 + ENC_{pa}^2$$

$$ENC_i^2 \propto I_{leak,a} \cdot \tau \quad ; \quad ENC_{th}^2 \propto \frac{T \cdot \tau}{R_b}$$

$$ENC_S^2 \propto \frac{C^2 \cdot R_s}{\tau} \quad ; \quad ENC_{pa}^2 \propto A(f) \cdot C^2$$

$\tau$  = peaking time,  $C$  = Capacitance at the input of the amplifier,  $A(f)$  = low frequency noise term

- A high peaking time increases the leakage current contribution to the noise but decreases the one due to serial resistors. Regarding the detector and its characteristics, one should reduce their leakage current, the series resistance and the total capacitance and increase the bias resistor resistance.
- $C^2 \propto 1/d^2$ ,  $d$  = distance between electrodes**

# Radiation damage effects in silicon detectors [2].

*\*Radiation damage dedicated lectures for more in-deep understanding*

- Semiconductor detectors can be exposed to radiation that induce defects in their crystalline structure:
  - Introducing new energy levels:
    - Acting as a **dopant** if it is close to one band
    - As an e-h generator if it is very deep on the band
  - *Frenkel pair* is formed when one atom is displaced (P in N-type or Si in P-type) creating an *interstitial defect* plus a *vacancy*. With enough energy absorbed can create clusters of defects.
    - Frenkel pairs have very high mobility at room temperature

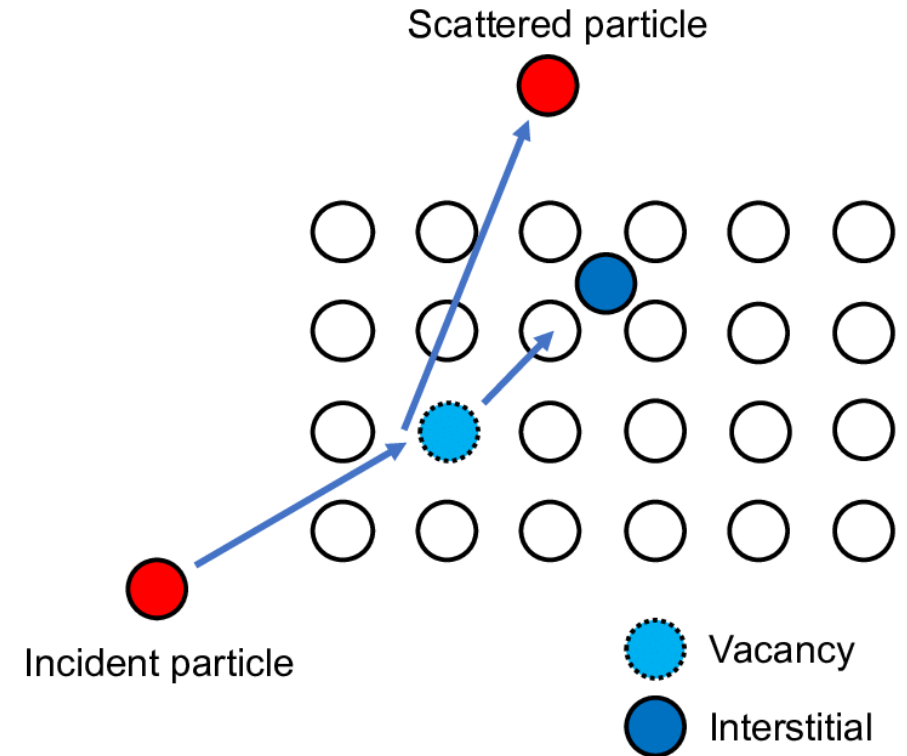

# Radiation damage effects in silicon detectors [2].

*\*Radiation damage dedicated lectures for more in-deep understanding*

- The NIEL (Non-Ionizing Energy Loss) model allows predicting macroscopic effects of radiation damage in silicon:
  - Assumes that bulk damage produced by ionizing radiation is proportional to the Non-ionizing energy lost by the particle through the sensor [6].

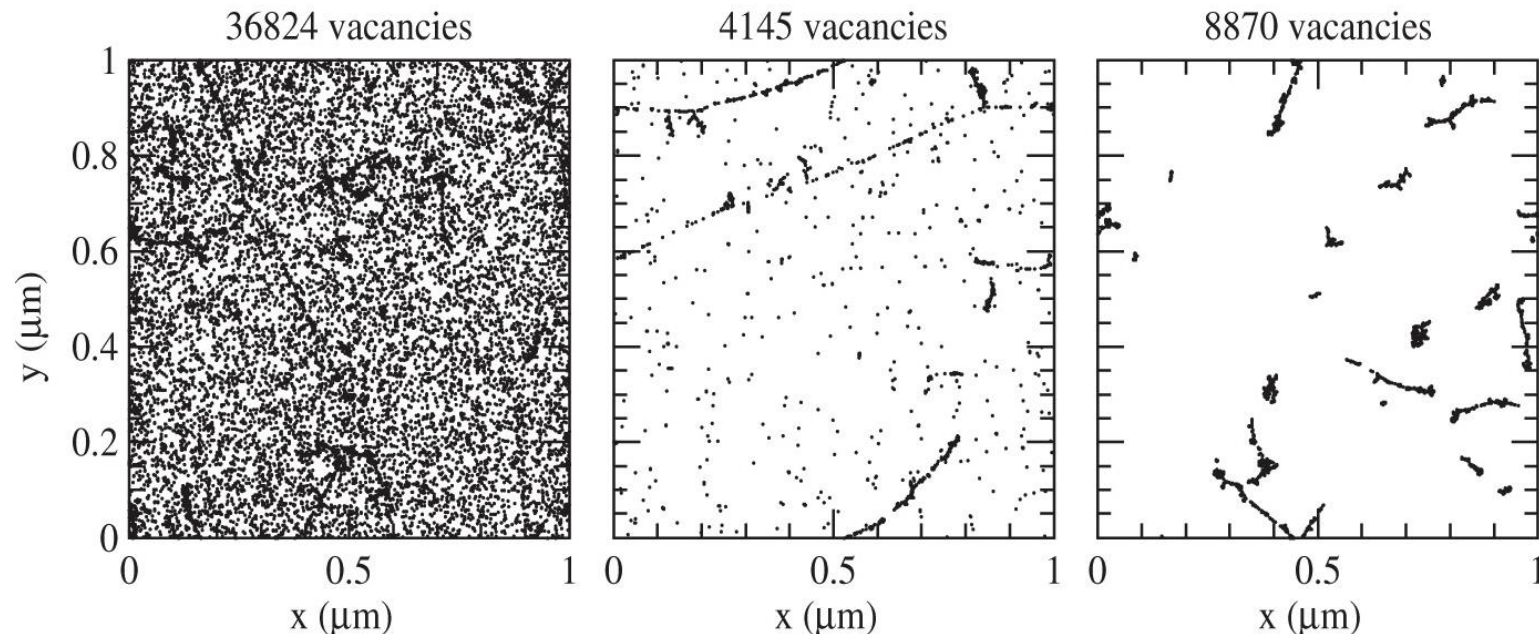

From [6]. Simulation of defects formation in silicon by different particles. Left: 10 MeV protons. Centre: 24 GeV protons. Right: 1 MeV neutrons.

# Radiation damage effects in silicon detectors [2].

*\*Radiation damage dedicated lectures for more in-deep understanding*

- Radiation effects on the detector performance:
  - Leakage current. Defects can create free e-h pairs in the depleted area contributing to the leakage current. This effect is proportional to the radiation fluence and bias voltage:

$$\Delta I_{leak}(\phi) = \alpha \cdot \phi \cdot V_{bias} \quad \alpha = \text{damage constant}$$

- Damage constant parametrisation in function of T and the annealing process can be found in M. Moll's PhD thesis [7]

*Annealing is a heat treatment that alters the material structure. It can be beneficial [7]*

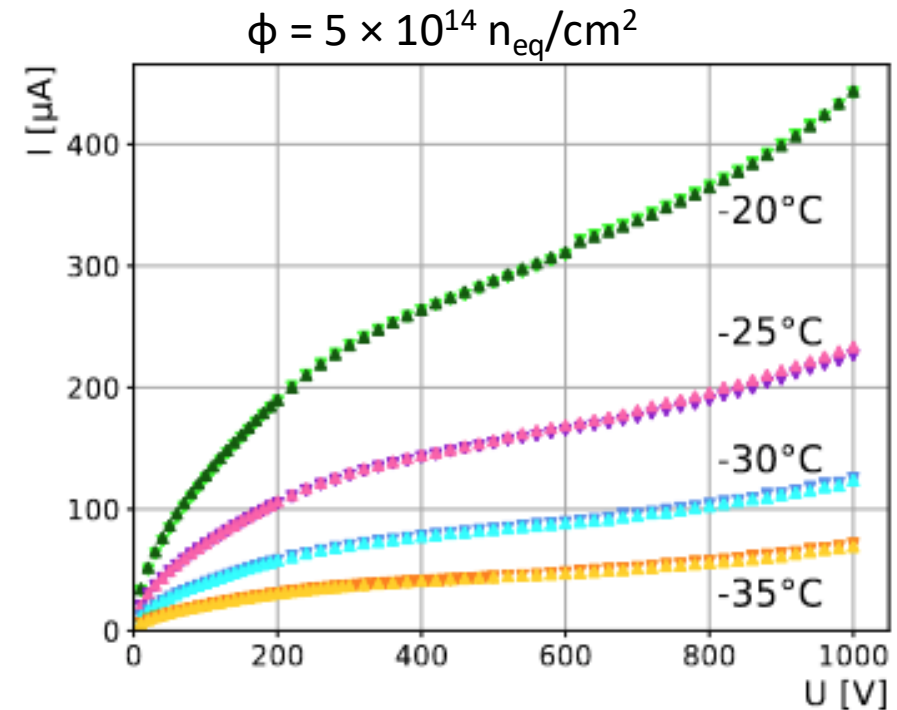

# Radiation damage effects in silicon detectors [2].

*\*Radiation damage dedicated lectures for more in-deep understanding*

- Radiation effects on the detector performance:
  - **Depletion voltage.**  $V_{fd} \propto |N_{eff}|$ .
    - Radiation produces defects that can act as donors or acceptors and change the effective dopant concentration.
    - “donor or acceptor removal effect” [8], dopants are moved and deactivated
    - “type inversion” in n-bulk sensors. When the sensor is biased, deep defects will be activated close to the two implants, forming two separate junctions. The p-like defects will be activated close to the n+ region and viceversa [9].

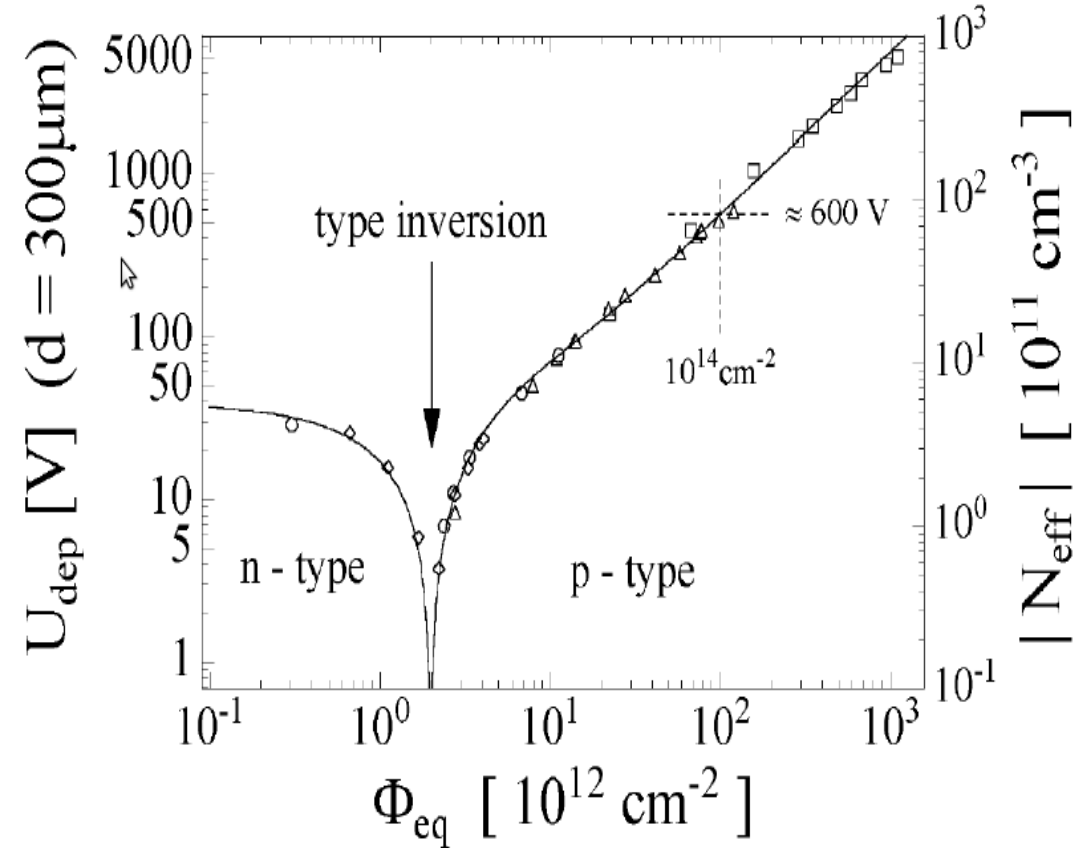

# Radiation damage effects in silicon detectors [2].

*\*Radiation damage dedicated lectures for more in-deep understanding*

- **Trapping.** Crystalline defects introducing energy levels with high capture cross section with re-emission time  $\sim$  ms. Trapped charge is lost. **Charge collection reduced.** Signal degradation.
- **Avalanche charge multiplication.** Sensors showing a **very high charge collection** after high irradiation fluences. High value of  $|N_{\text{eff}}|$  can create localised high  $E$ .
- **Surface damage.** Defects on the passivation  $\text{SiO}_2$  layers produce:
  - Oxide ionization: electrons escape and a positive charge on the layer, compensated by a negative charge in the bulk.
  - Creating **shorts between segmented electrodes.**
  - Two main techniques to compensate for that to adapt depending on the device and application [10]:
    - P-spray: adding a p-type layer between sensor bulk and passivation layers
    - P-stop: p-type silicon “barrier” surrounding the electrodes

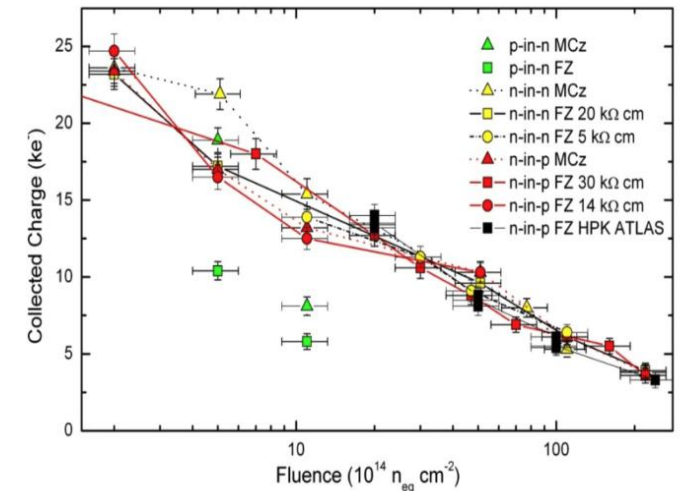
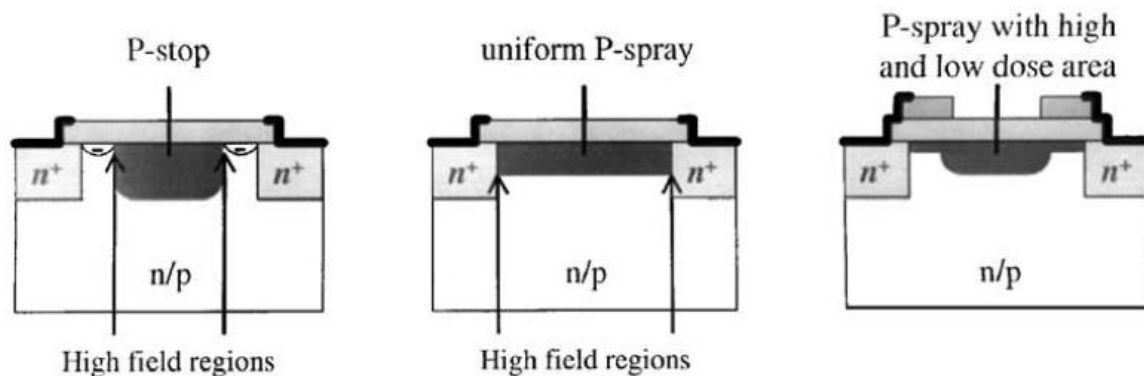

# Position resolution[3]

- Position resolution is given by the size of the electrode (to first order):
  - Electrode size is also limited by:
    - Wafer size
    - Electronics bonding (interconnection technique )
  - Electrodes are segmented into strips or pixels ('strixels' also exist)
    - Sensors remains 100% efficient despite the gaps (field lines remain parallel until near the surface ) provided:
      - $V_{bias} > V_{FD}$
      - Un-irradiated sensors
  - Segmentation in the junction side or the ohmic side
  - We talk about p-on-n, n-on-n, n-on-p sensors:
    - P-on-n: collect holes
    - N-on-n or n-on-p: collect electrons (higher mobility). P-type bulk avoid type inversion

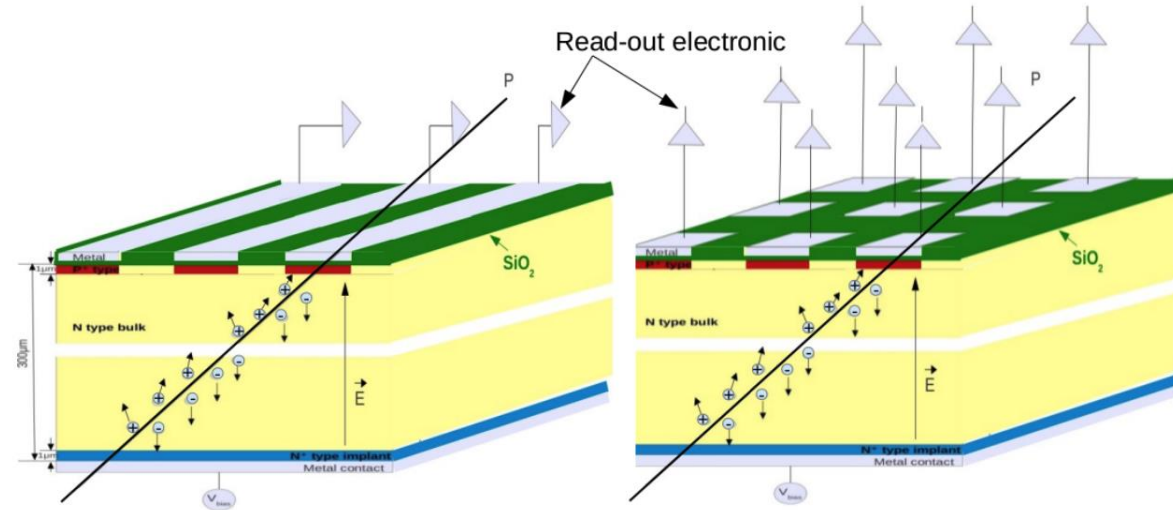
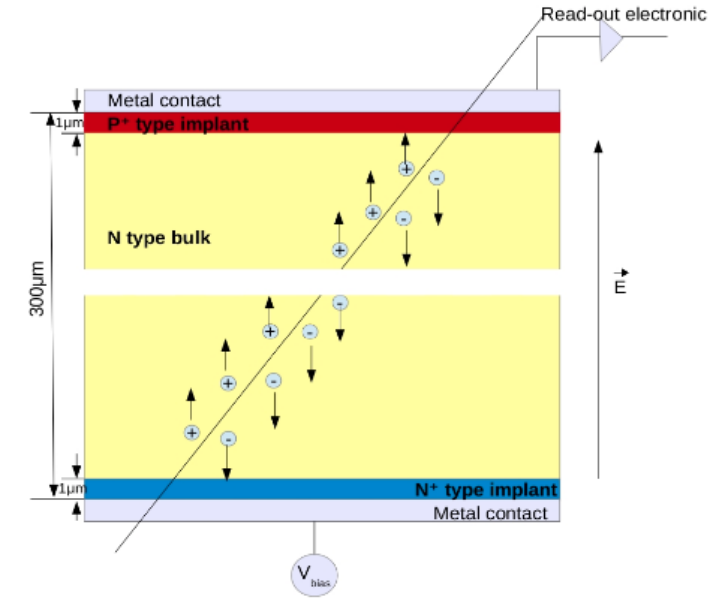

# Position resolution[3]

- Position resolution:

- Diode → Pitch 'p'
- Strip or pixel detector. Tracks randomly aligned with the strip, the difference between the measured and the real position have a gaussian distribution with the standard deviation:

$$\sigma^2 = \int_{-p/2}^{p/2} \frac{x^2}{p} dx = \frac{p^2}{12},$$

- Transverse diffusion (the phenomenon), thermal spread of the charges with an RMS width  $\sigma^2 = 2Dt$ :

- D is the diffusion constant, proportional to the carrier's mobility ( $=kT\mu/e$ )
- Using the average field approximation:  $E = V/d$
- t is the collection time, inversely proportional to the mobility  $t \sim d/v = d/(\mu E) = d^2/(\mu V)$
- The transverse diffusion is independent of the carrier

$$\sigma_y = \sqrt{2Dt} \approx \sqrt{2 \frac{kT}{e} \frac{d^2}{V_b}}$$

- Charge sharing between electrodes (the effect).

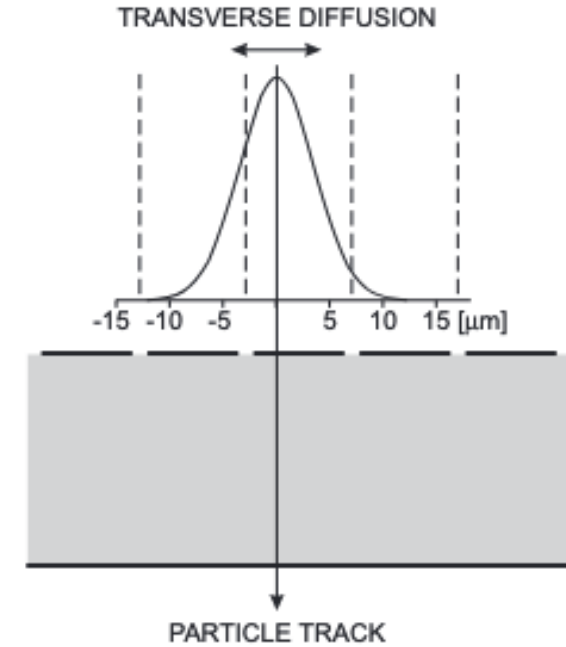

Q2: what do you think is the effect of the transverse diffusion in the position resolution? Beneficial or detrimental?

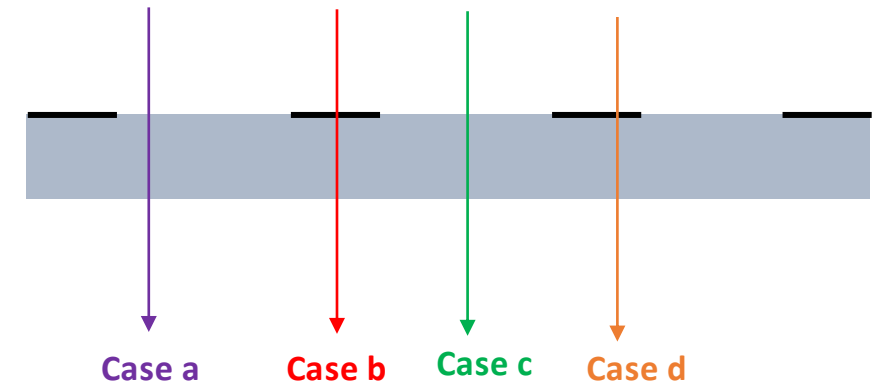

# Position resolution[3]

- Position resolution:
  - Diode → Pitch 'p'
  - Strip or pixel detector. Tracks randomly aligned with the strip, the difference between the measured and the real position have a gaussian distribution with the standard deviation:

$$\sigma^2 = \int_{-p/2}^{p/2} \frac{x^2}{p} dx = \frac{p^2}{12},$$

- Transverse diffusion (the phenomenon), thermal spread of the charges with an RMS width  $\sigma^2 = 2Dt$ :
  - D is the diffusion constant, proportional to the carrier's mobility ( $=kT\mu/e$ )
  - Using the average field approximation:  $E = V/d$
  - t is the collection time, inversely proportional to the mobility  $t \sim d/v = d/(\mu E) = d^2/(\mu V)$
  - The transverse diffusion is independent of the carrier

$$\sigma_y = \sqrt{2Dt} \approx \sqrt{2 \frac{kT}{e} \frac{d^2}{V_b}}$$

- Charge sharing between electrodes (the effect).

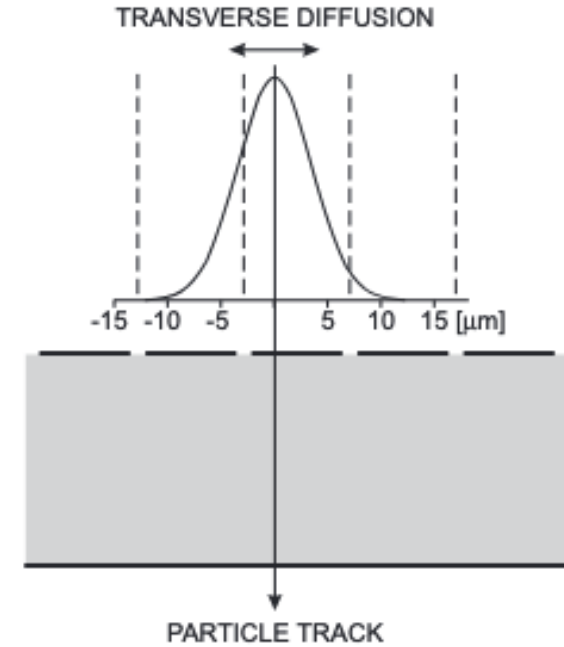

Q2: what do you think is the effect of the transverse diffusion in the position resolution? And on which circumstances is beneficial?

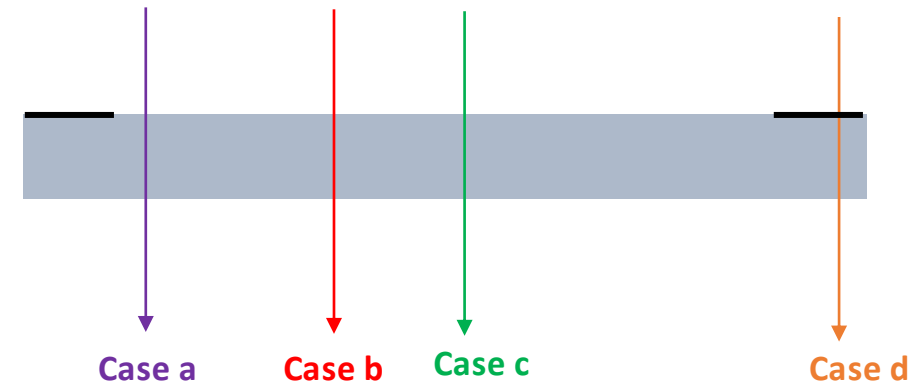

# Devices structures [2]

Q3: Any guesses on advantages and disadvantages from 3D sensors with respect to planar ones?

- Electrode position: Planar vs 3D (surface or embedded)
  - 3D sensors were proposed by S. Parker in 1997 [4]
  - They can be strip or pixel sensors

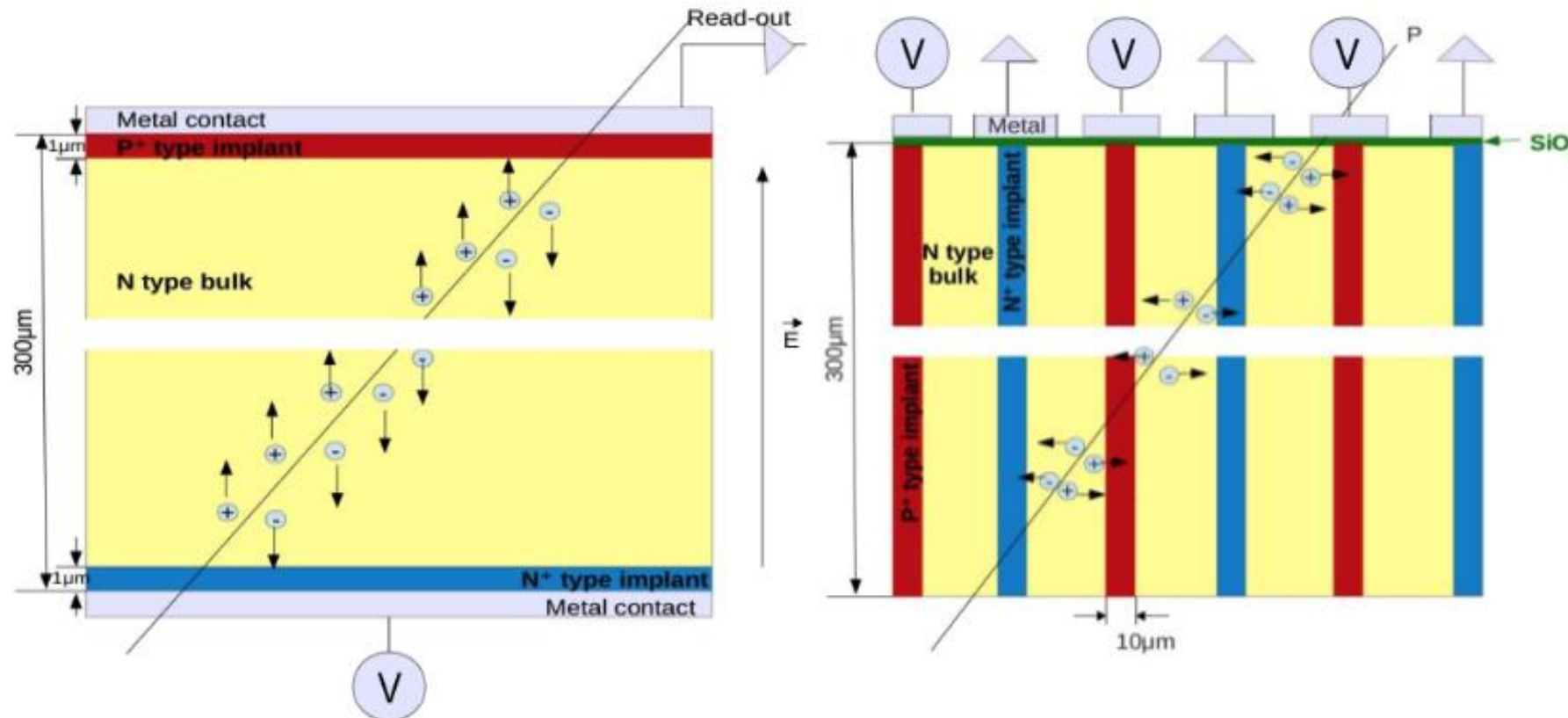

# 3D structures characteristics[2]

- In 3D devices, distance between electrodes no more limited by the sensor thickness.
- Full depletion voltage now is given by the coaxial approximation [11]:

$$V_{FD} = \frac{qN_{eff}}{2\epsilon_0\epsilon_{Si}} \left( D^2 \left[ \ln\left(\frac{D}{r} - 0.5\right) \right] + 0.5r^2 \right)$$

D = Electrode distance  
r = column radii

- Smaller  $V_{FD}$
- Shorter distances to travel for carriers
- Input capacitance is higher than in planar → challenging for ROC

$$C = \frac{2\pi\epsilon_0 d}{\ln\left(\frac{D}{r}\right)}$$

- short collection distances, fast collection times and low depletion voltages

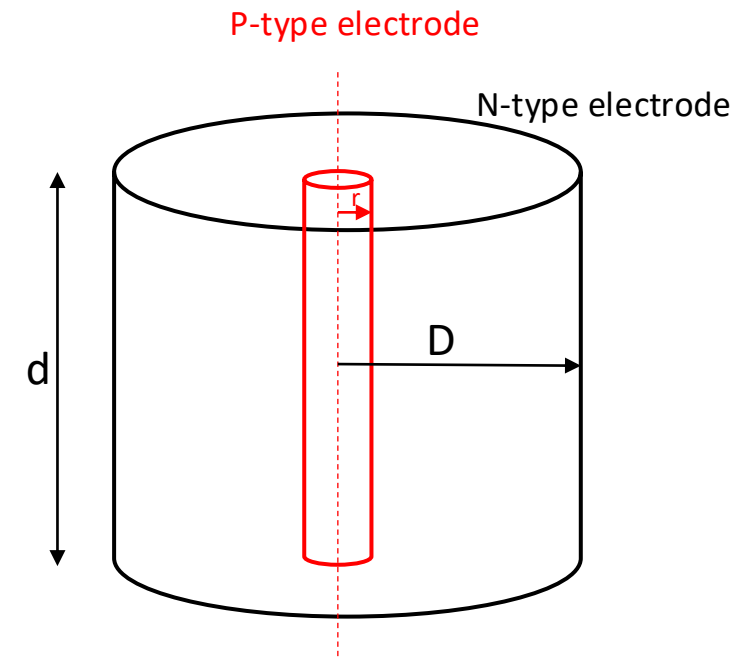
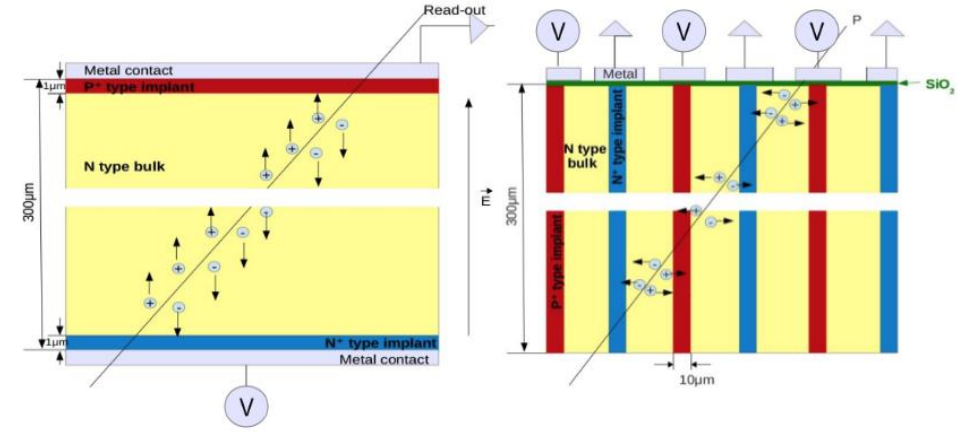

# 3D sensors fabrication [2]

- Single sided [5] or double-sided [2] processing:
  - Double sided require less fabrication steps
  - Single sided allow to fabricate thinner sensors that require a support wafer

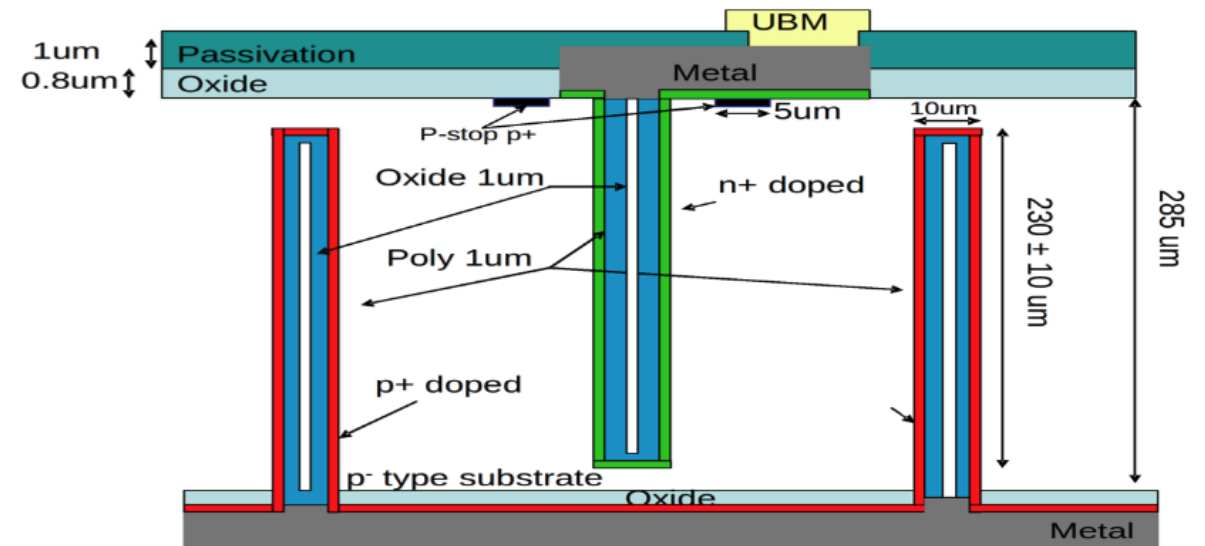
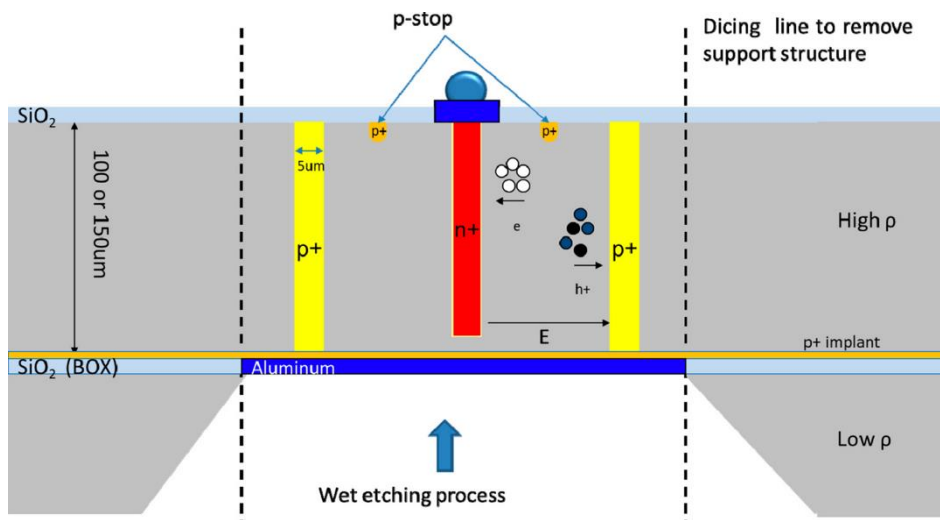

# 3D sensors fabrication [2]

- Schematic of the fabrication process of double-sided 3D silicon detectors. The first step is the p-stop implantation, then the polysilicon deposition plus the Boron diffusion create the ohmic contacts and an oxide barrier is grown. The same process is followed to create the junction columns but diffusing Phosphorus instead of Boron. The last step is to metalize and passivate both sensor sides.
- Deep Reactive Ion Etching (DRIE)
- In single sided 3Ds you have to dope the two different types from the same side, adding some steps in the fabrication

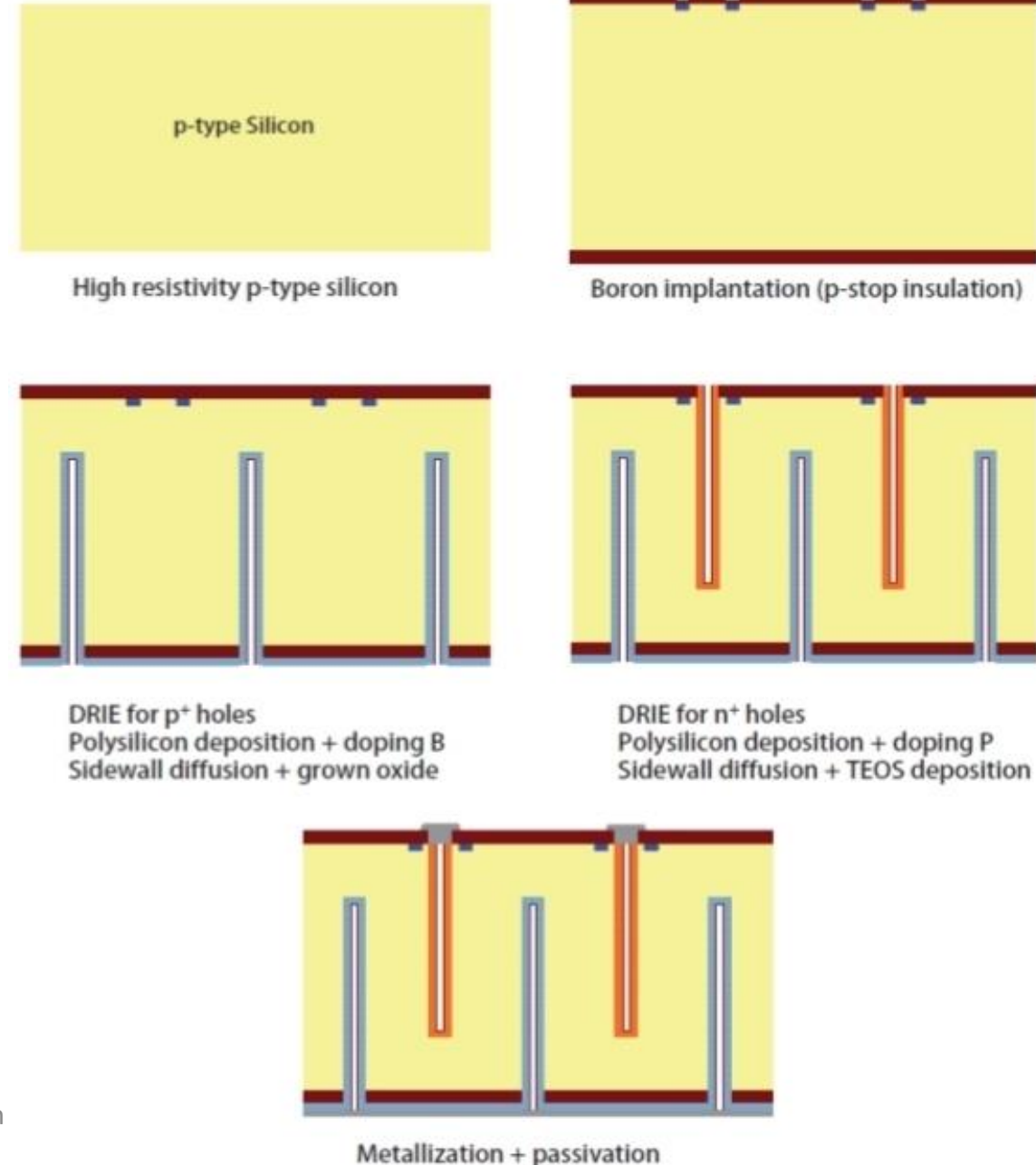

# 3D sensors fabrication [2]

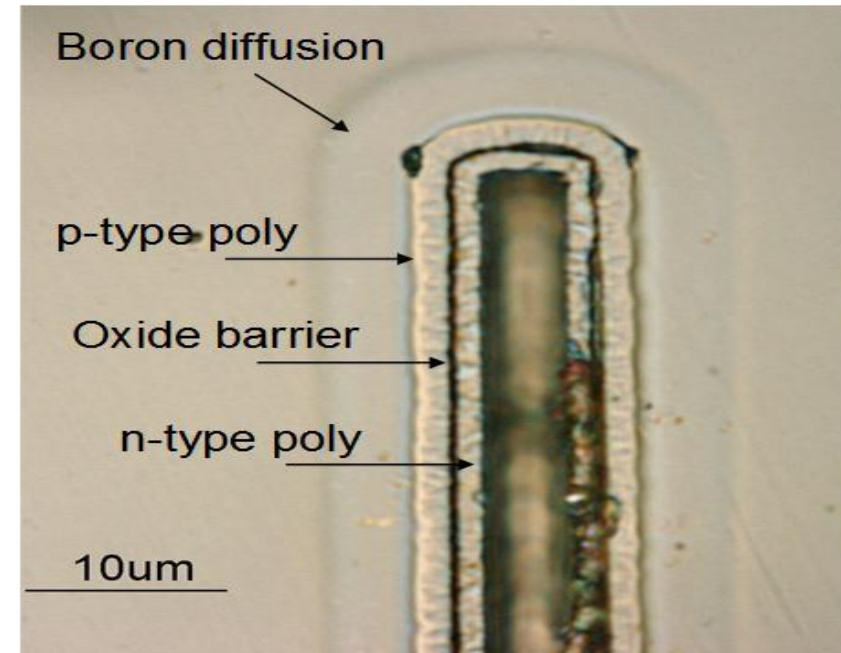
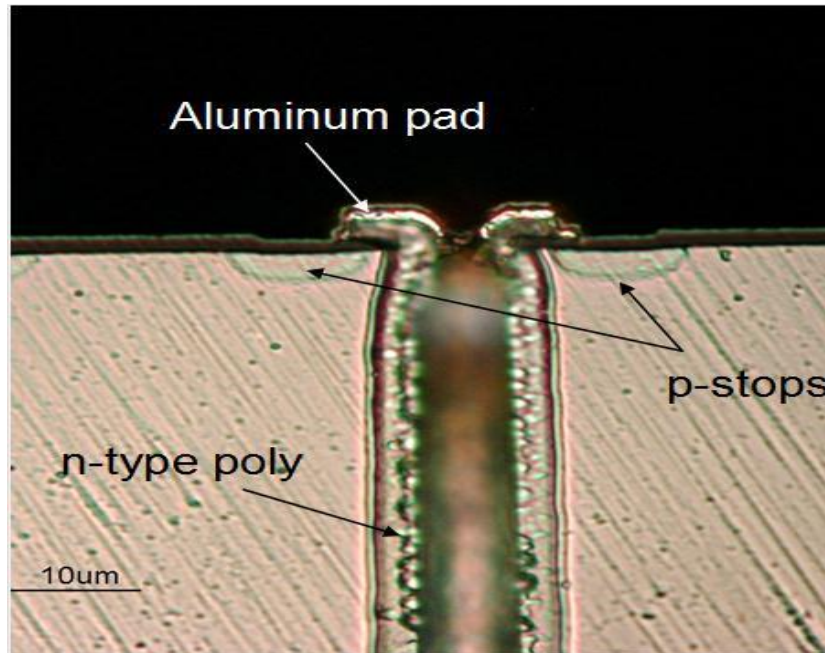

- Microscope pictures of 3D pixel sensors. Left: n-column in p-type silicon bulk, the p-stop implantation and polysilicon layer for diffusion are visible. Right: p- columns (ohmic junction) where the Boron diffusion and the two polysilicon layers separated by an oxide barrier can be appreciated.

# Hybrid detectors[2]

- Hybrid detector: sensor and Read-Out chip (ROC) are developed separately, an interconnection process is required:
  - Microstrips detectors → Ultrasonic wire bonding
    - Microstrip pitch must adapt to the electronics, or a pitch adapter is required



ATLAS-SCT strip module

- Pixel detectors → bump bonding (electrochemical process) + wire bonding

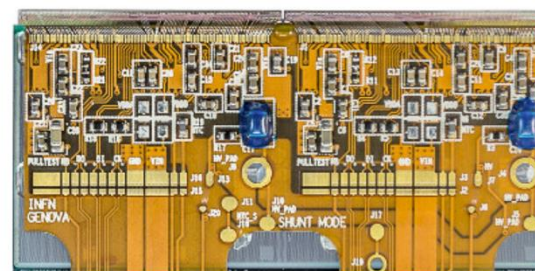
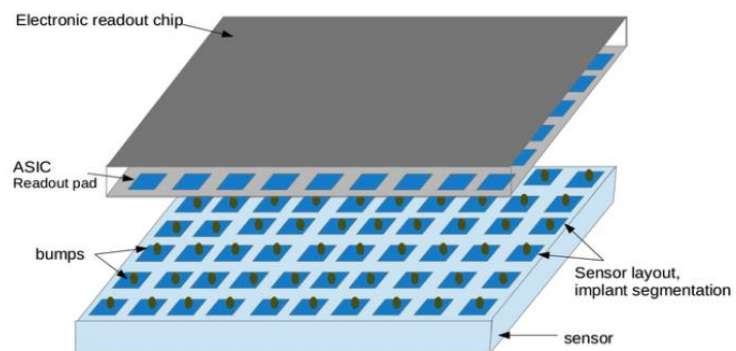

(a)

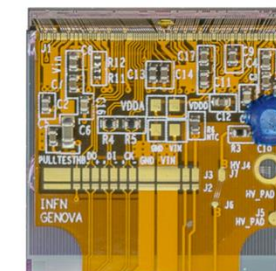

(b)

ATLAS-IBL pixel modules

# Sensor's interconnections [2]

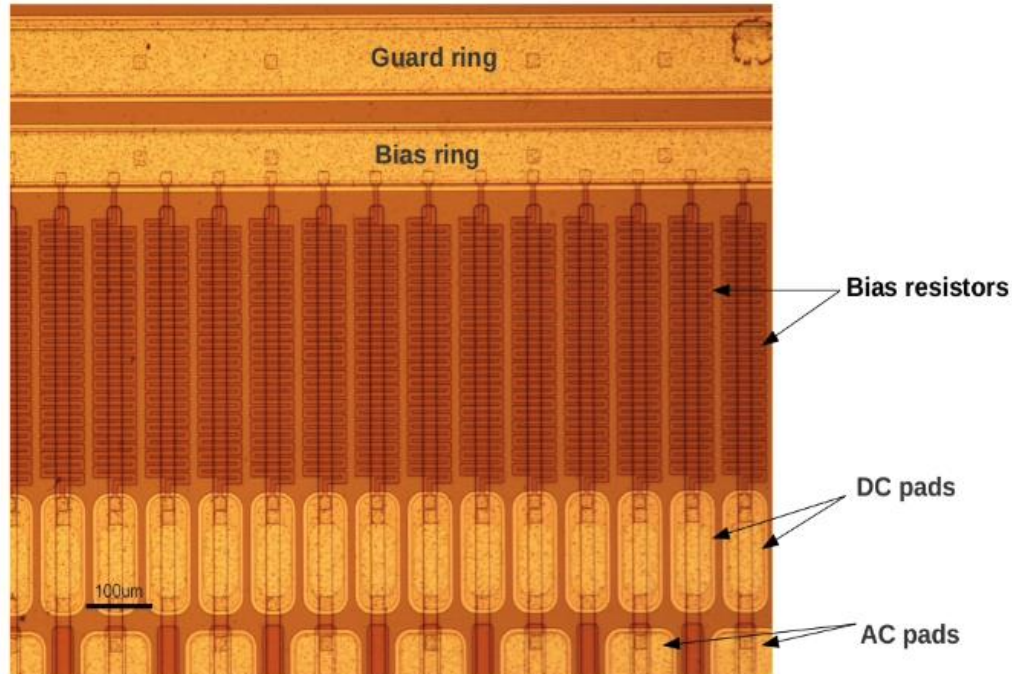

- Sensor to ROC interconnection. Each strip or pixel of a silicon sensor must be connected to its own readout channel. This can be done in two different ways:
  - DC coupling: direct connection from the strip or pixel to the electronics. The amplifier should sink part of the leakage current (common approach in pixels)
  - AC coupling: bypass the DC leakage current over a resistor and pick up only the AC part over a capacitor (common on strips where the leakage current can be significant)
    - In silicon strip detectors, resistors and coupling capacitors are usually integrated into the sensor. The bias resistor is commonly implemented as a polysilicon structure, which is less vulnerable to radiation damage.

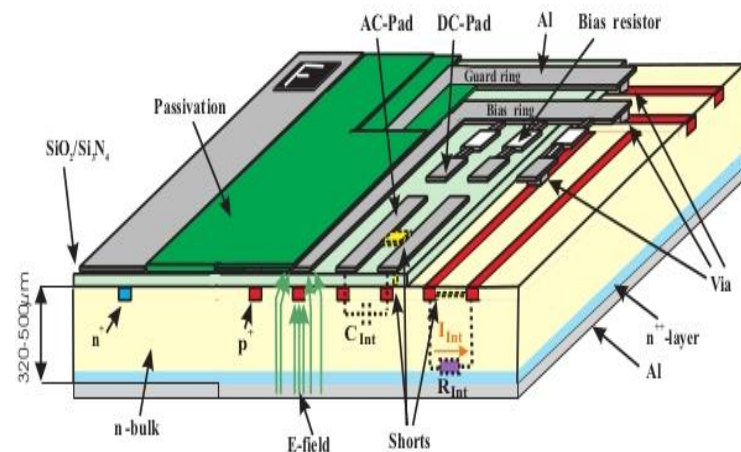

# Bump bonding technique

Right figure from [13]: Diagram of indium bump-bonding technique. From (a)-(g) is the under-bump metallization in case of the sensor and from (i) to (n) in case of the ASIC chip (all these steps are made on wafer). Step (h) is the first “reflow” after dicing. Steps (o) and (p) are the flip-chip process and the final step (q) is the second and final “reflow” after which the contact is finally stable and robust.

•Techniques available:

Electroplating = EP  
Stencil Printing = SP

Solder ball placement = SBB  
ENIG = Electroless Ni/Au.

Evaporation = EV

**Standard FC bump**

- EP
- ENIG + SP
- ENIG + SBB

**FC fine-pitch bump**

- EP
- ENIG + SBB
- C4NP

**FC  $\mu$ -bump**

- EP

**Cu pillar bump**

- EP

**SLID**

- EP

**In bump**

- EV & lift-off

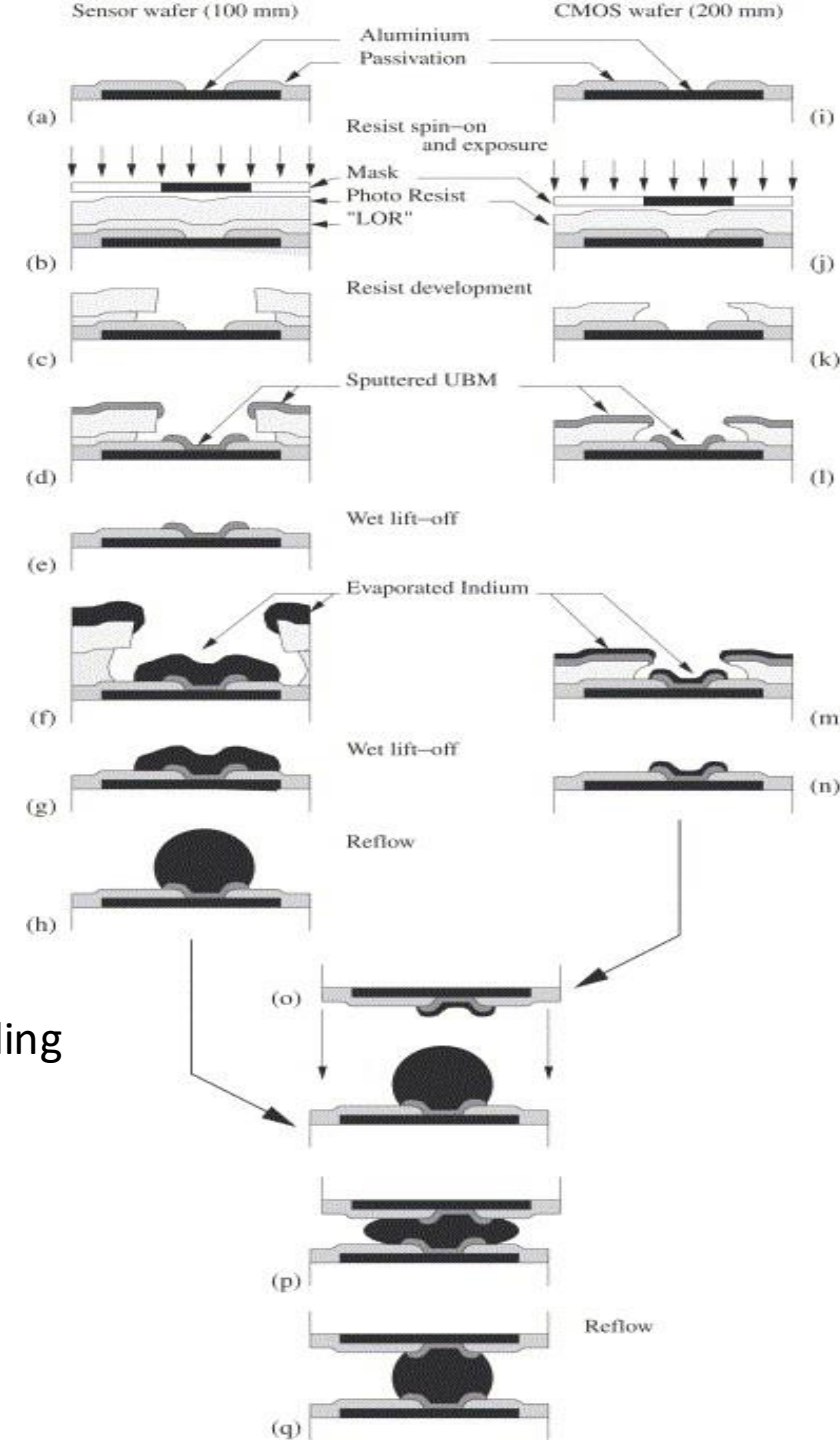
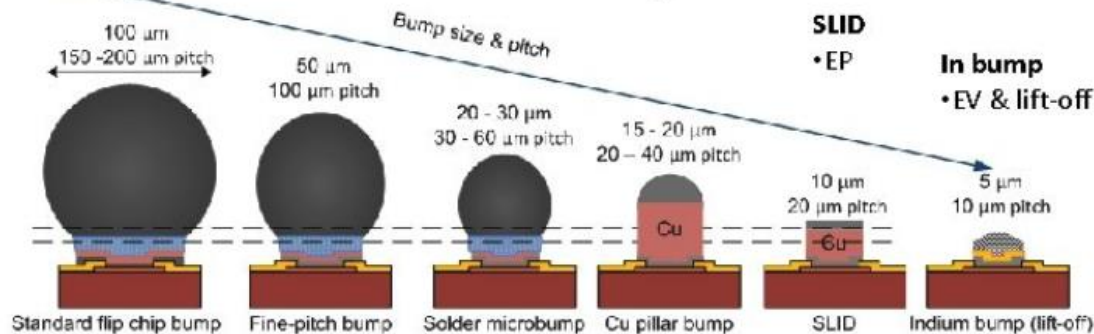

Left figure from [14]. Different bump-bonding Techniques.

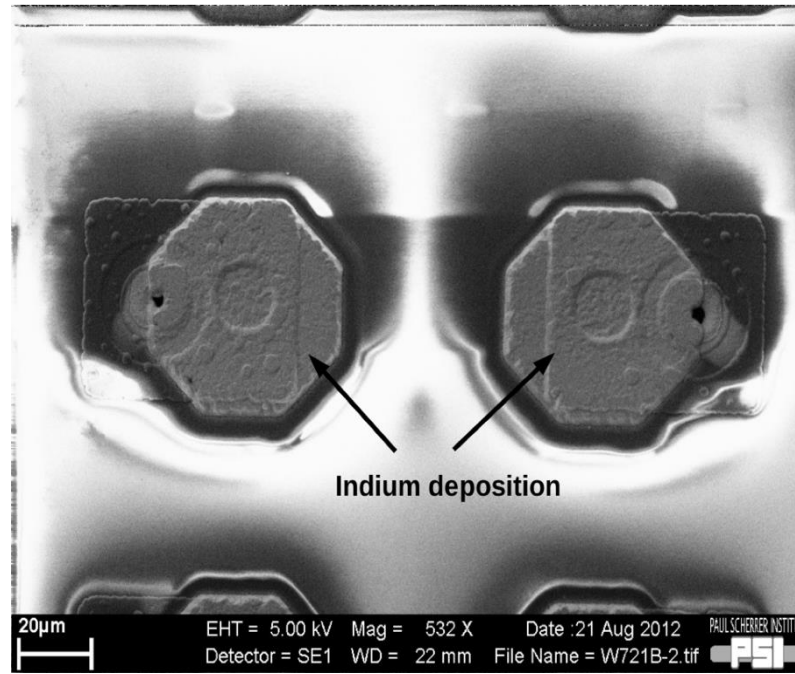
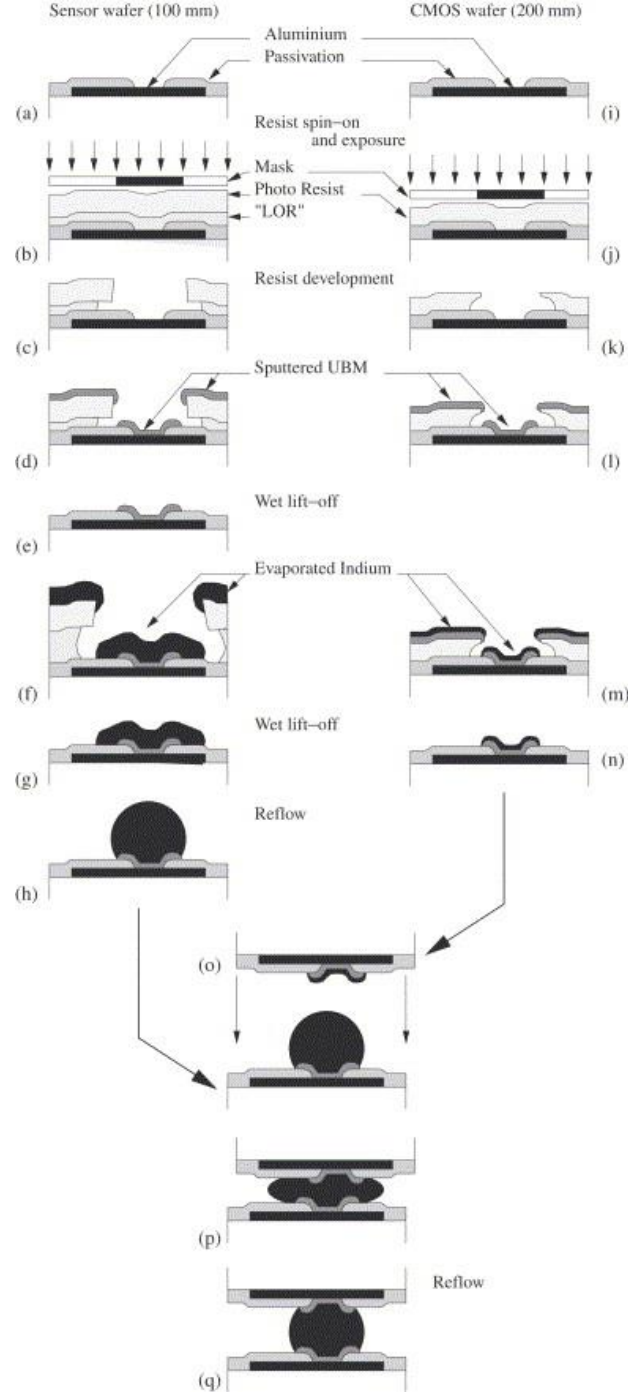

# Bump bonding technique [2]

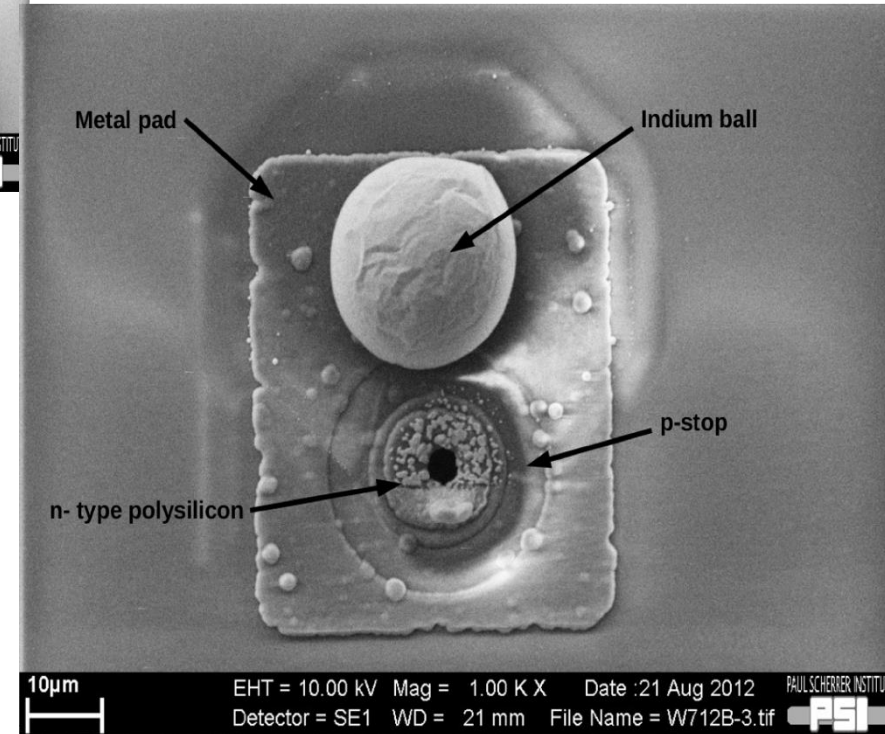

Scanning electron microscope pictures of indium bumps (Top) before and after (Right) reflow in 3D pixel sensors. The bumps pitch is of 100  $\mu\text{m}$  and the reflowed bumps diameter is of 20  $\mu\text{m}$ .

# Collider experiments applications

Q4. Where do we use strips and where do we use pixels, and why? 3Ds?

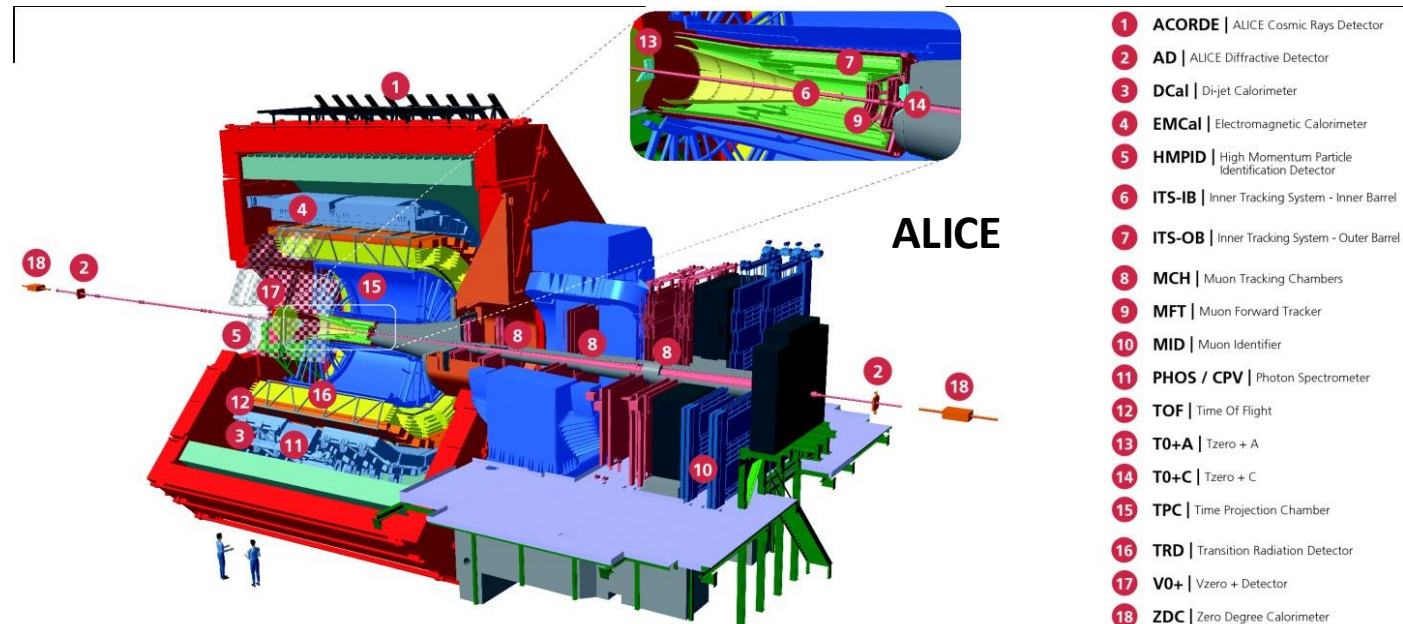
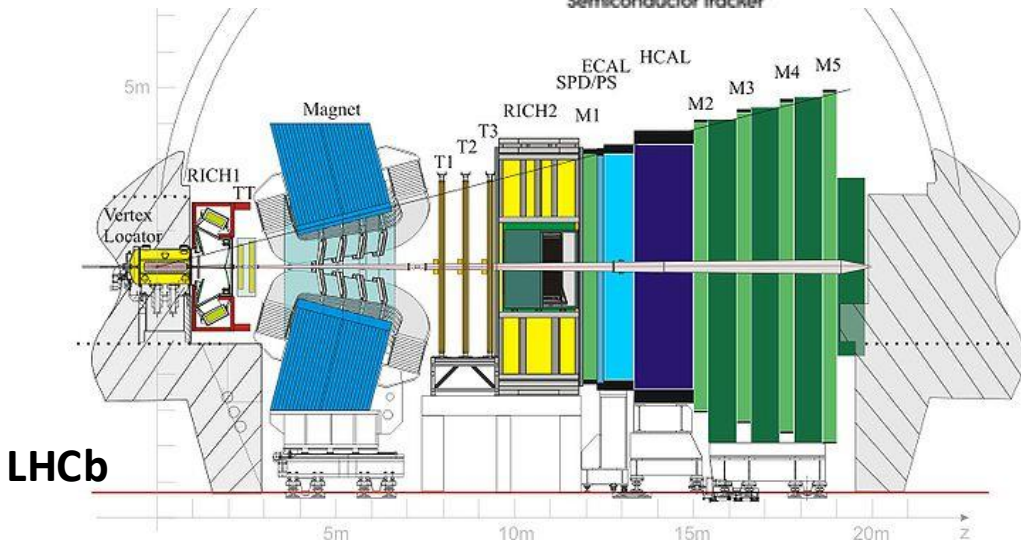
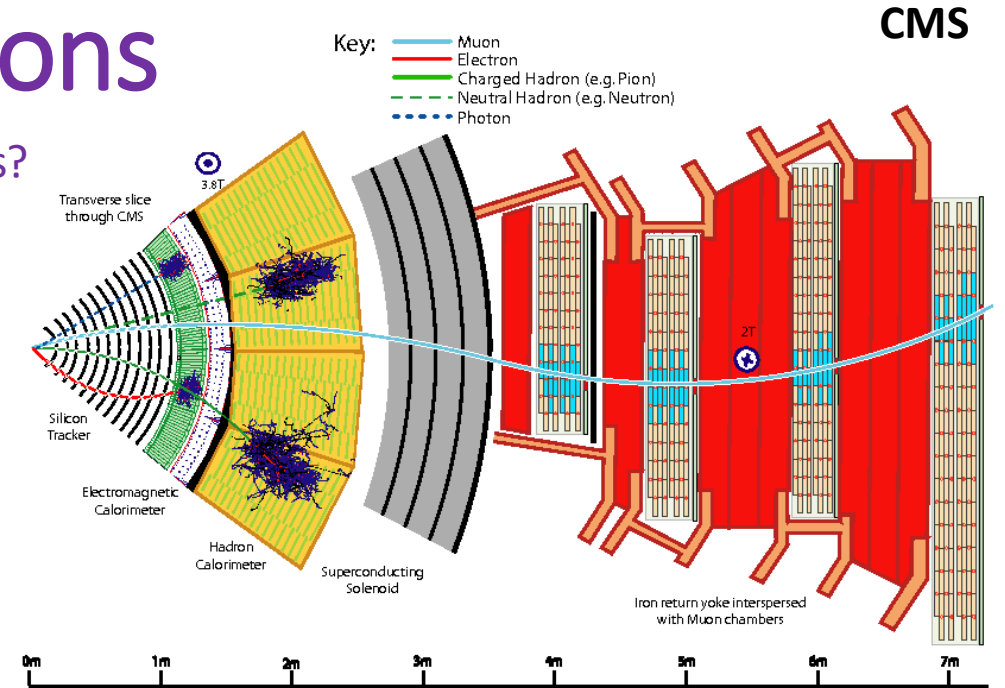
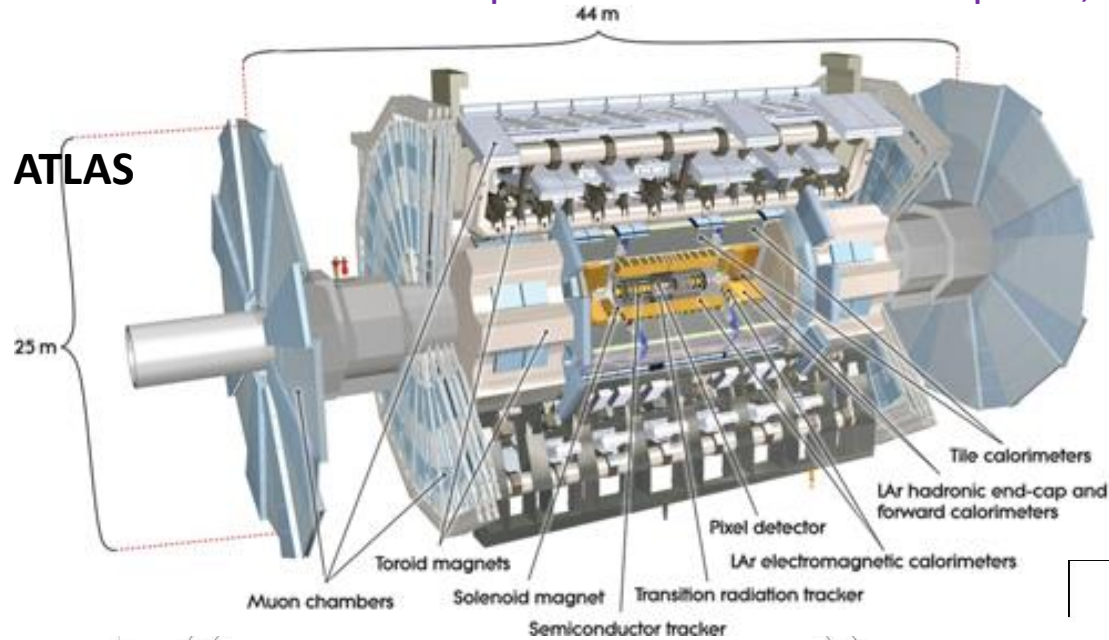

# Micro –Strip detectors developments.

- Strip-detectors are used on the outermost layers of the trackers because they can cover bigger areas, and less position resolution is required.
- There are also mitigation strategies to improve position resolution on strip detectors:
  - Geometry optimisation
  - Stereo angles
  - Integrated pitch adapter
  - Double sided

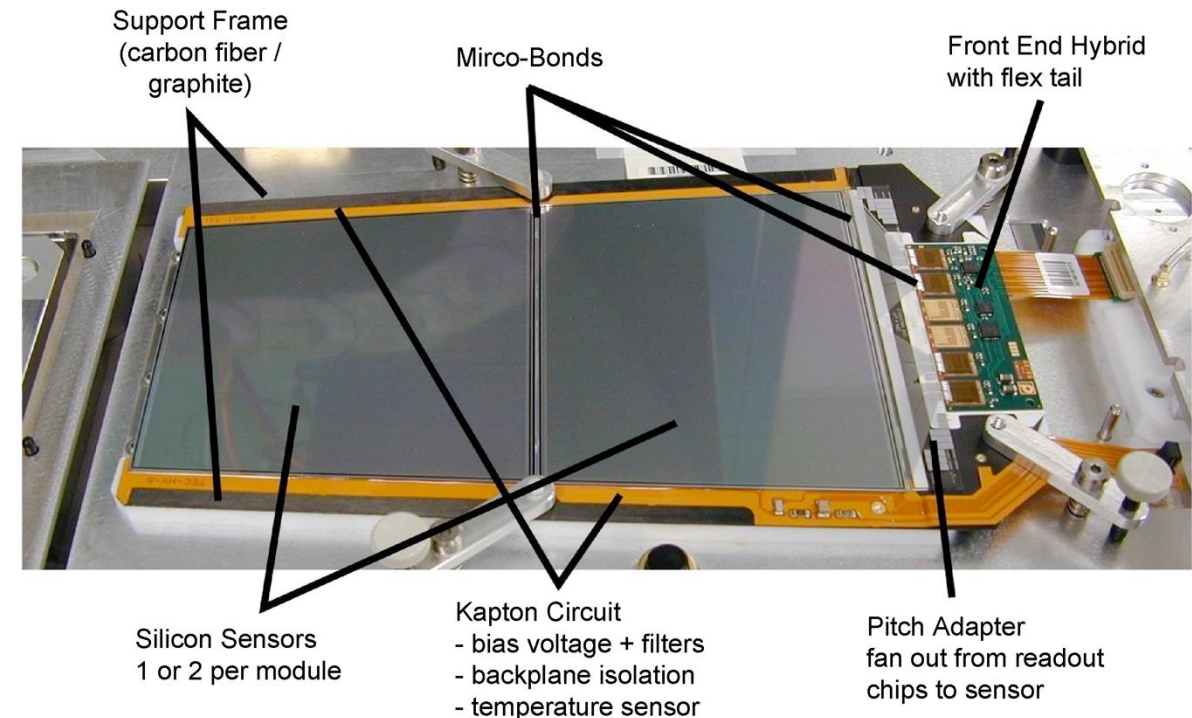
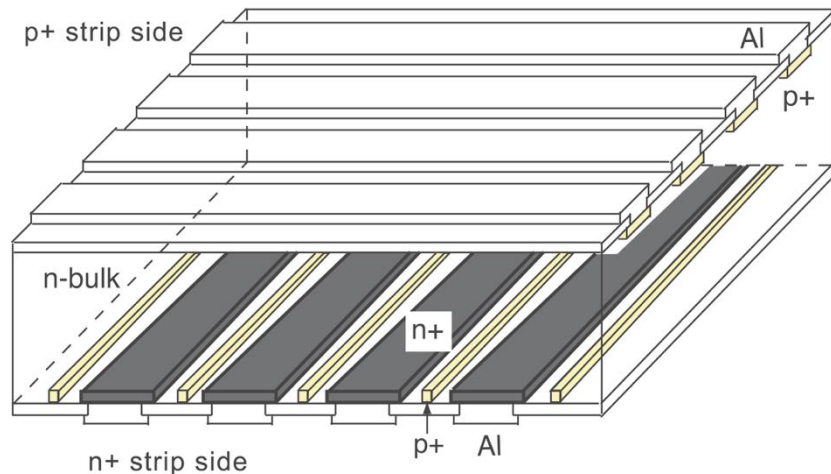
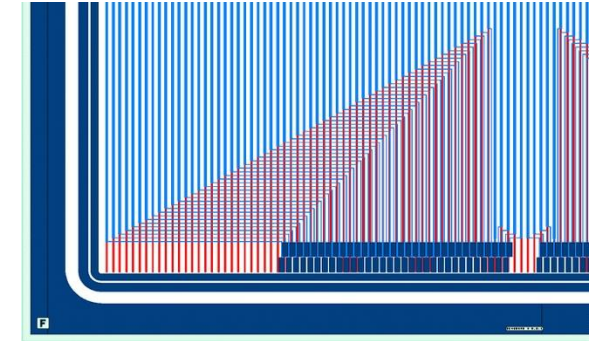

fmunoz@cern.ch

28

# Micro –Strip detectors. One example of today in ITk [15].

- 8 sensors geometries:
  - 2 for the barrel, 6 for endcaps
  - 320 um thick n-in-p silicon
  - 70 -80 pitches
  - 1 sensor/silicon wafer
  - $V_{bias}$  (100-500v)

SS, LS are barrel, R# are end-cap

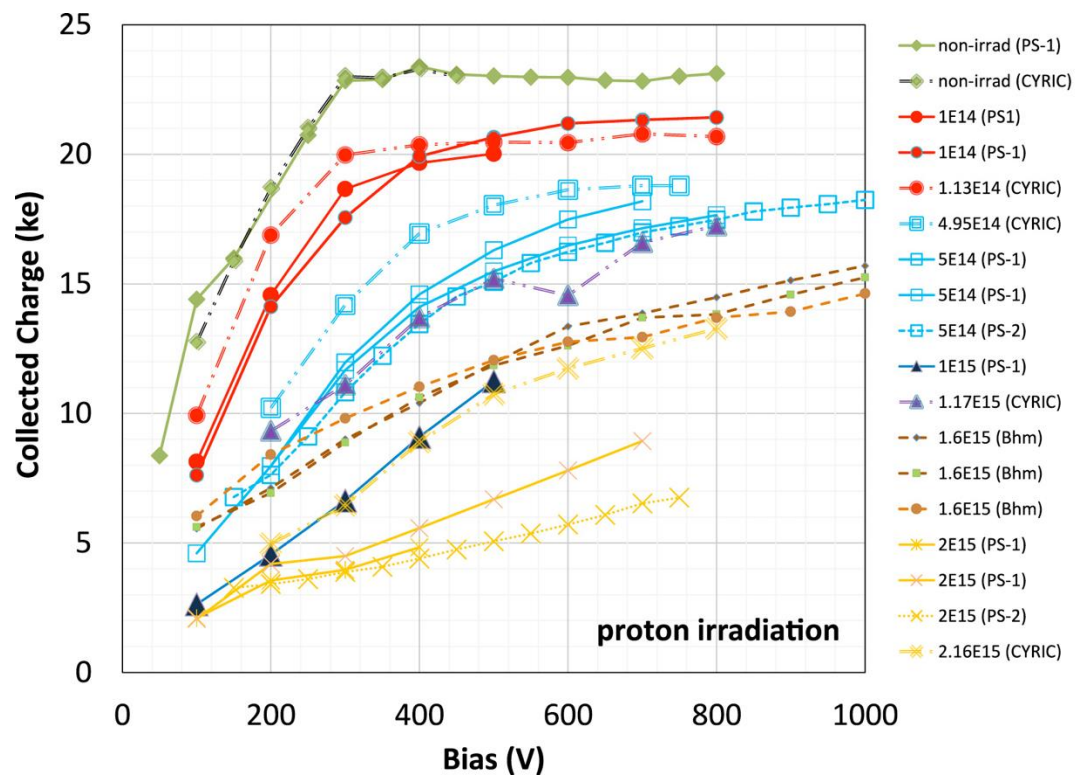
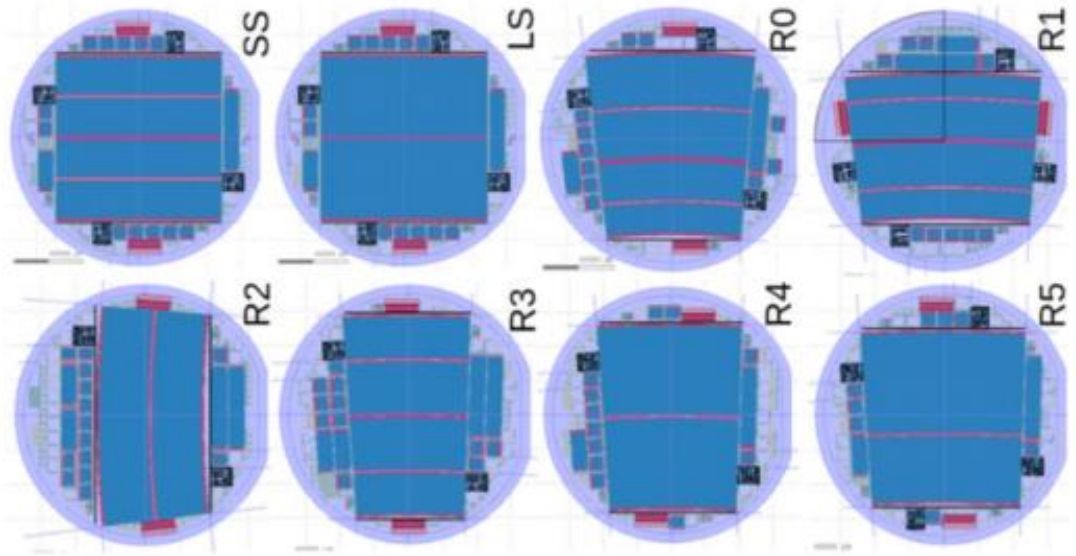

Max. expected +SF =  $1.6 \times 10^{15} n_{eq}/cm^2$

Q5. Why not thinner?

(When we have pixel sensors 150 um thick)

# Pixel detectors developments.

- Pixel detectors are in the innermost layers:
  - Smaller areas to cover up and higher resolution requested
  - Pixel detectors are more expensive
- The developments have been on:
  - Thinning sensors
  - Smaller pixel size
  - Interconnection yield (bump bonding)
  - Getting closer to the beam pipe
  - Bigger area ROC (and thinner)
  - Radiation Hardness

ATLAS ID – pixel module (50 x 400  $\mu\text{m}^2$ )

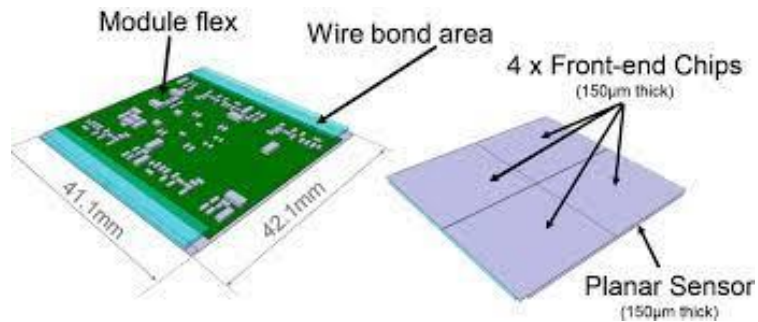
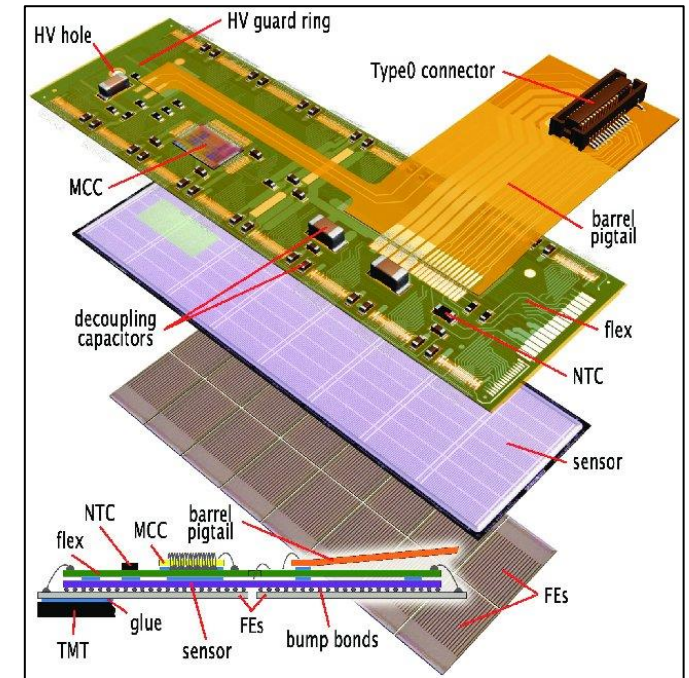

ATLAS ITk – QUAD module (50 x 50  $\mu\text{m}^2$ )  
Triplet (25 x 100  $\mu\text{m}^2$ )

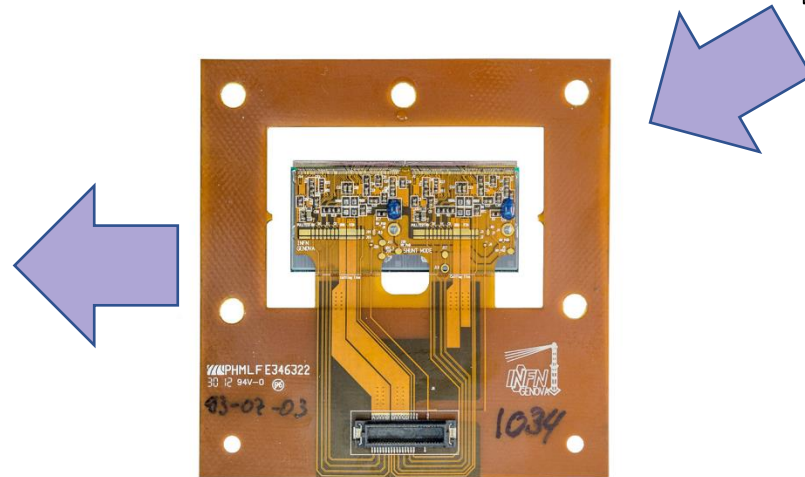

ATLAS IBL – pixel dual- module  
(50 x 250  $\mu\text{m}^2$ )

fmuoz@cern.ch

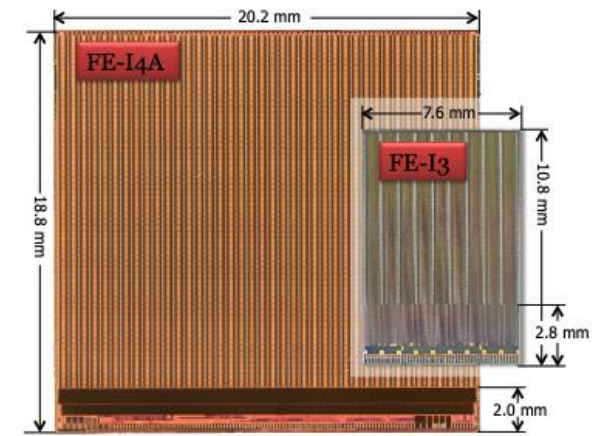

30

# Radiation Hardness in the innermost layers of the pixel detector.

- At HL-LHC innermost layers we need technologies capable to cope with high irradiation doses ( up to  $2 \times 10^{16} n_{eq}/cm^2$  ). Thin devices of both, planar and 3D technologies.
  - The innermost layer of both CMS and ATLAS will be made on 3D pixel technology

Q6. Why 3D? Why only in the innermost layer? and what are the challenges?

- Planar technologies elsewhere. To decrease the  $V_{FD}$  and trapping they must be very thin
- Trackers in collider experiments are operated at very low temperatures!  $\sim -35C$  (sensor  $\sim -20C$ )

Q7. Why? What do we avoid?

# Pixel detectors. One example of today in ITk [15].

- 5 layers of silicon pixel system
  - Quad modules with Thin n-in-p planar silicon sensors (50 x 50  $\mu\text{m}^2$ ) in L1 to 4.
    - 100  $\mu\text{m}$  thick in L1  $\rightarrow$  400V
    - 150  $\mu\text{m}$  thick in the rest  $\rightarrow$  600V
  - Triplet modules with 3D silicon sensors in L0 (34 mm from the beam pipe).
    - 150  $\mu\text{m}$  thick (effective)
    - 50 x 50  $\mu\text{m}^2$  pixel size  $\rightarrow$  70V
    - 25 x 100  $\mu\text{m}^2$  pixel size  $\rightarrow$  100V
    - Single sided processing
    - Production yield

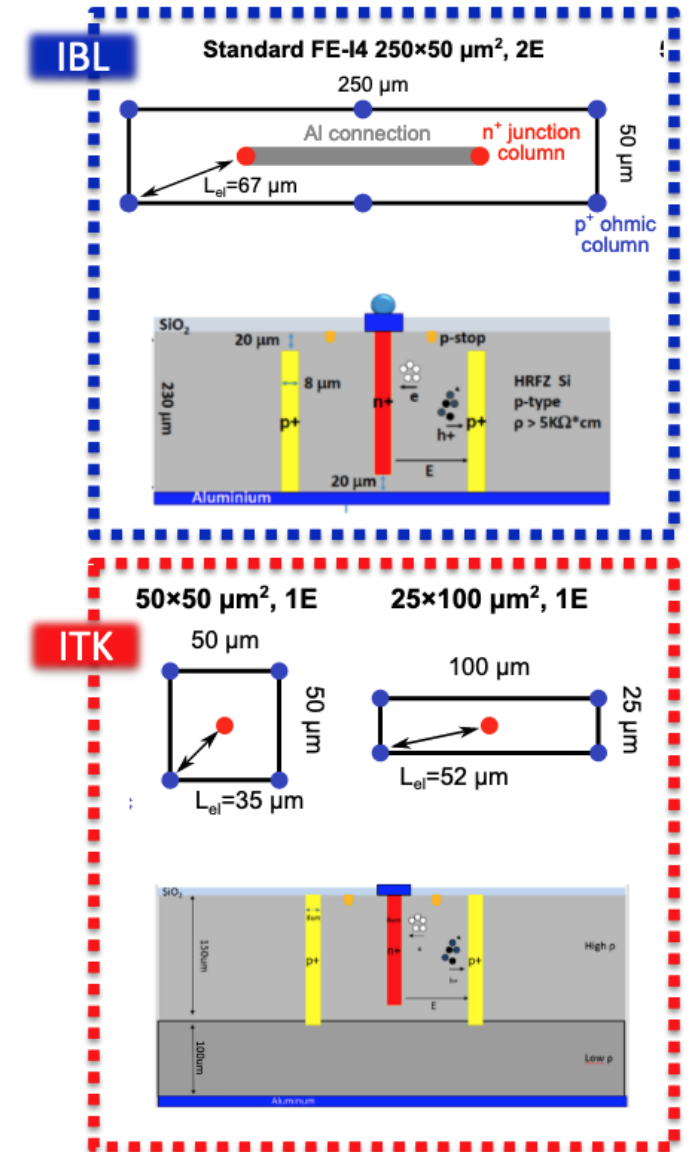
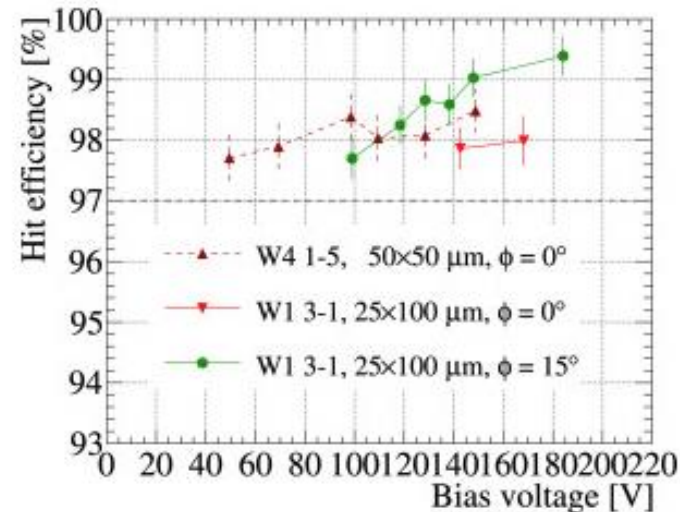

# Future challenges for hybrid detectors

- Higher radiation resistance → better performance
  - Both ROCs and sensors
- Smaller pitch → higher position resolution
  - Interconnection technique pitch, cost and yield with thin ROCs and sensors
  - Data handling (optic data transmission in high radiation environments)
- Timing information to cope with higher track density
  - Faster charge collection :
    - 3D trench sensors
    - LGADs

# 3D trench sensors [16]

- Timing detectors with high time resolution will become the next generation of detectors for future colliders with very high instantaneous luminosity

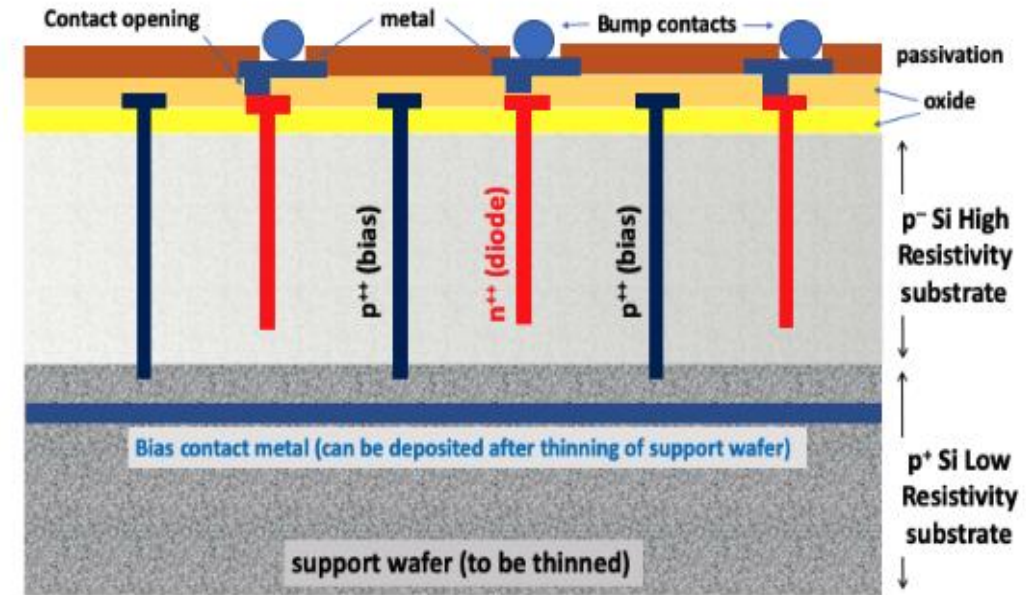
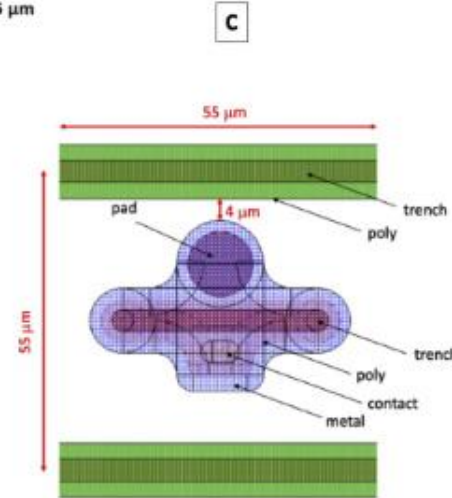
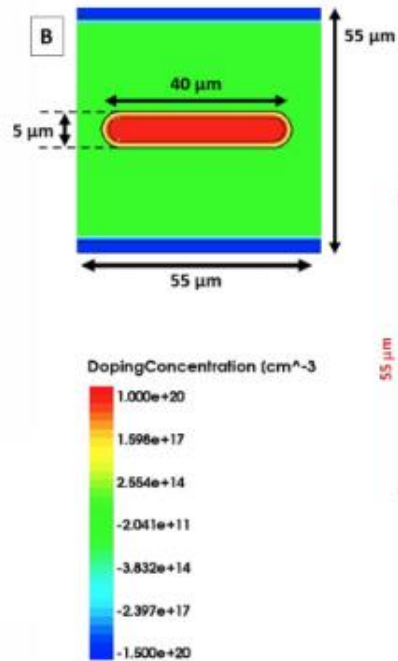
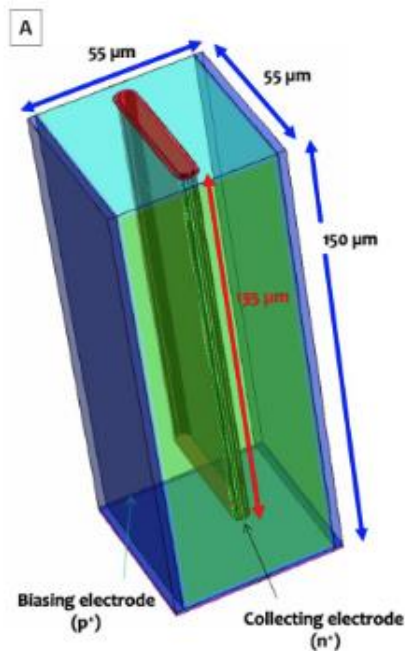

First results show time resolution between 20 and 40 ps

# Other semiconductor detectors

*\* More on Alexander Oh lectures*

- Diamond detectors: it is a very good semiconductor:
  - Large band gap  $\rightarrow$  low noise (also smaller signal)
  - High thermal conductivity  $\rightarrow$  very low power dissipation
  - Large displacement energy  $\rightarrow$  low radiation damage
  - Operates as an ionisation chamber (no pn-junction or doping is required)
  - Only the metal electrodes to collect the charge are required
- 3D diamond detectors use laser to create the columns (electrode) via graphitization of the diamond

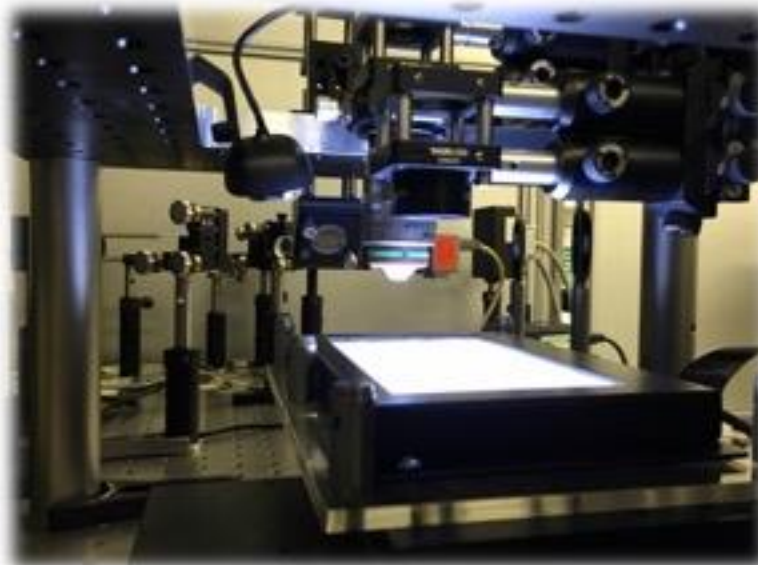
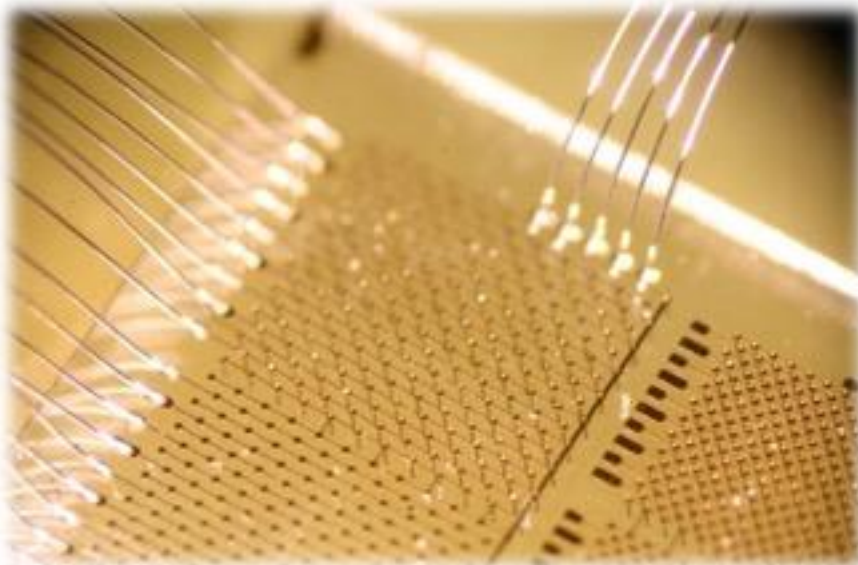

# Other semiconductor detectors

- Germanium-based [17]:
  - Same working principle than silicon
  - High atomic number, favourable to  $\gamma$  detection
  - Low band gap  $\rightarrow$  cooling down (77K)
  - Lower energy needed to generate pairs
  - High Energy resolution
  - Used in X-rays and gamma detection
  - Low-mass dark matter detection at cryogenic temperatures (mK): CDMS. Phonon detection .

Back and front of a Ge-detector

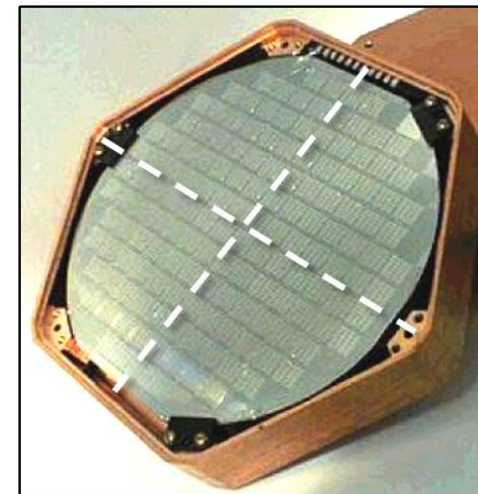

CDMS Ge-detector

# Some “exotic” ideas

- 2D position sensitive microstrip detector [2] ( $p=160\mu\text{m}$ ,  $p_{\text{electronics}}=80\mu\text{m}$ )
- **Polysilicon strips** to produce charge division along it.
- In the measurement the clear charge distribution among strips is shown, together to the event signal, there is some coupling contribution
- Polysilicon strips are very useful for alignment sensors (transparent to IR)

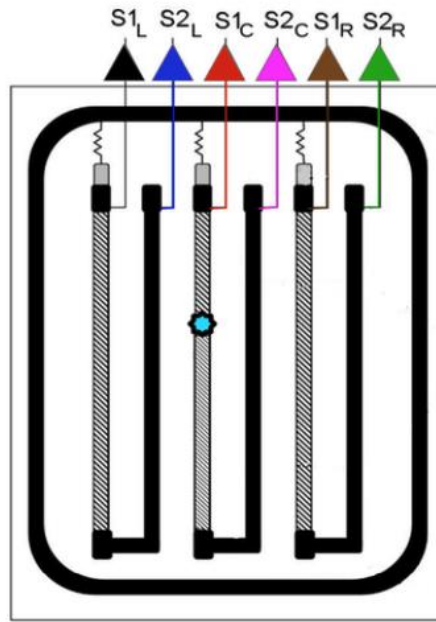
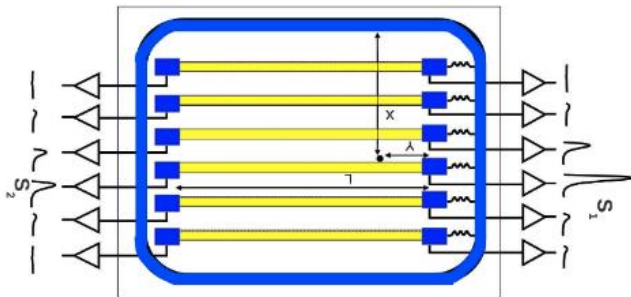

(a)

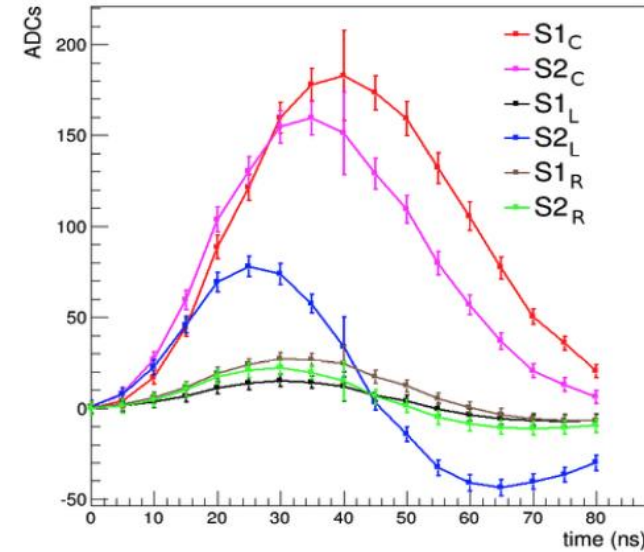

(b)

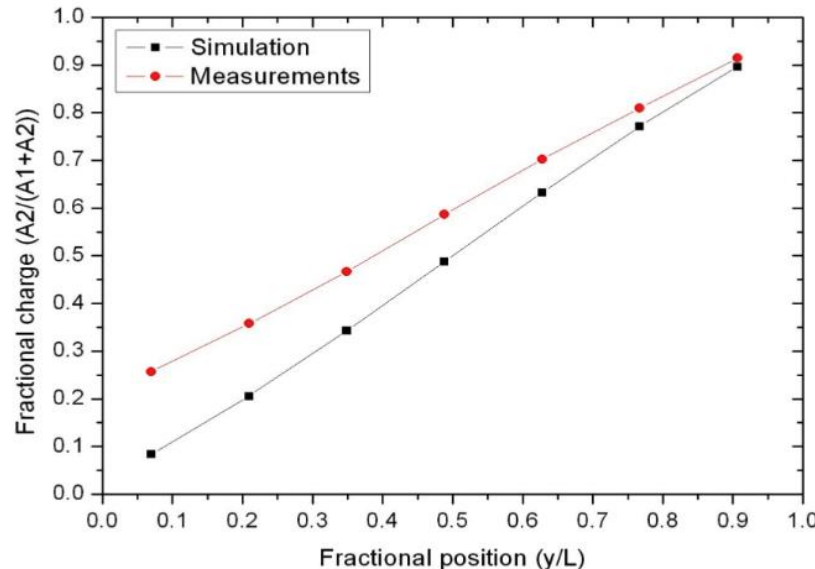
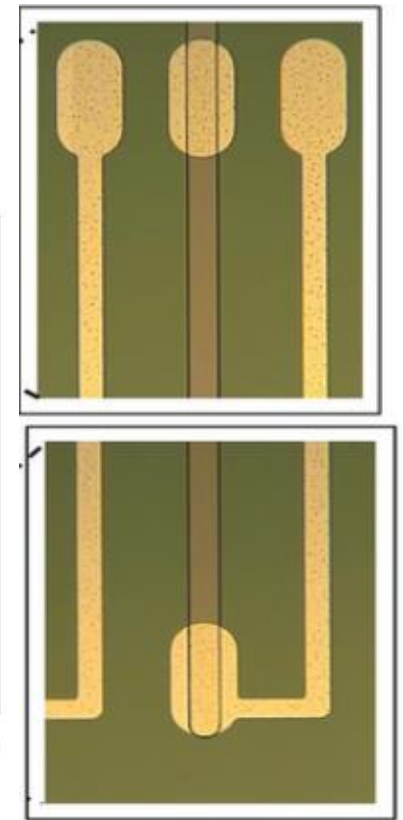

Q8. Look carefully to the results.

Can you understand the blue signal?

# Some “exotic” ideas

- The development that could revolt the hybrid detectors technology will be to find a more efficient and less expensive technique to stack up sensors and read out electronics (you will have dedicated lectures on monolithic sensors)
- The three techniques here shown allow finer pitch (RDL-redistribution layer):
  - solid-liquid inter-diffusion
  - Anisotropic conductive film
  - Face-to-face bonding
- There is a significant effort on R&D for better yields

(a) SLID Bonding



(b) ACF Bonding

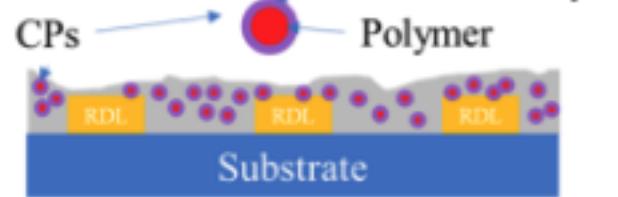

(c) Hybrid Bonding



Ideal Bonding Result

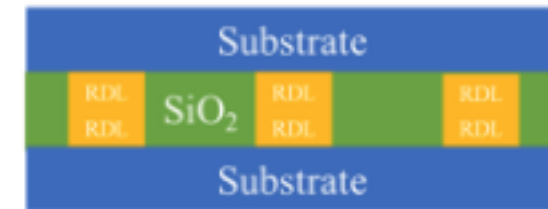
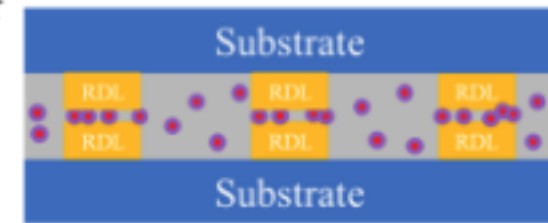
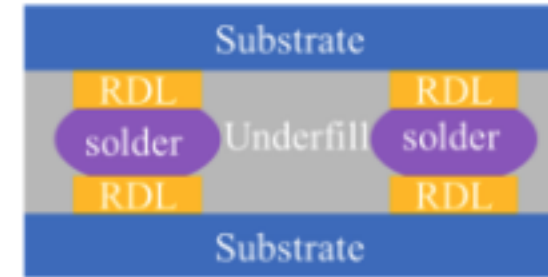

# Some “exotic” ideas

- 3D-integration detectors [18]
  - Inter-Chip Vias (ICV)

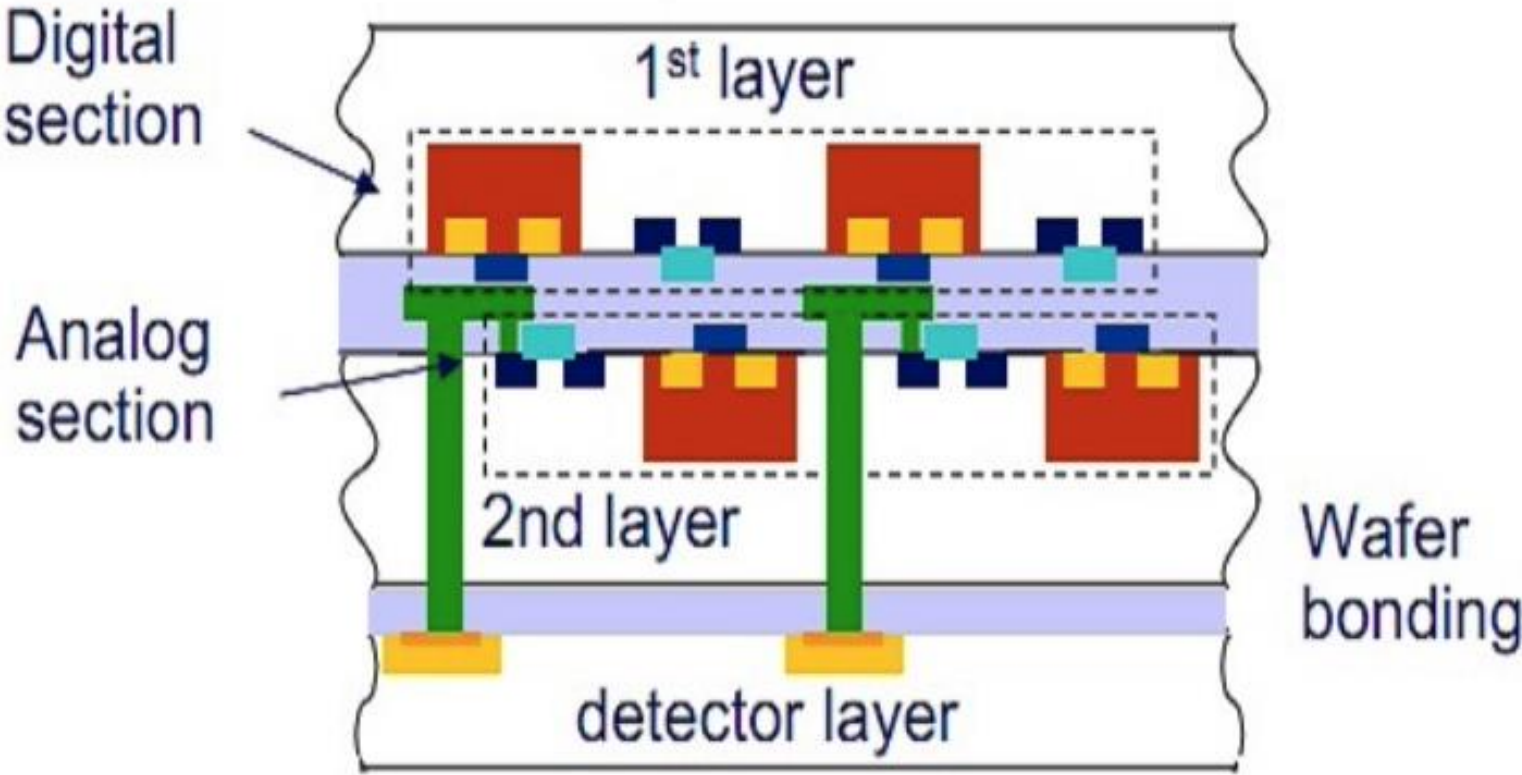

# Questions

## Discussion:

- I haven't talk about services at all! But they are crucial!
- What do you think is the future/limitations of hybrid detectors for collider trackers? Planar and 3D?
- Advantages and dis-advantages?
- How would you build the best detector performance-wise using these technologies?
- Any missing information that you would add to this lecture?

## Feedback Please!

# References

- [1] Gregor Kramberger. "Signal development in irradiated silicon detectors". PhD thesis, University of Ljubljana. Faculty for Mathematics and Physics, 2001.
- [2] F. J. Munoz. "Study of New Silicon Sensors for Experiments at Future Particle Colliders", PhD thesis, IFCA-University of Cantabria, 2014.
- [3] Helmuth Spieler. "Semiconductor Detector Systems", Oxford university press, 2005. PDF available [here](#).
- [4] S. Parker et al. "[3D — A proposed new architecture for solid-state radiation detectors](#)", Nucl. Instrum. Meth. A 395 (1997) 328.
- [5] G. Pellegrini et al. "[3D-Si single sided sensors for the innermost layer of the ATLAS pixel upgrade](#)", Nucl. Instrum. Meth. A 924 (2019) 69
- [6] M. Huhtinen. "[Simulation of non-ionising energy loss and defect formation in silicon](#)". Nucl. Instr. and Meth. in Phys. Res. A, 491(12):194 – 215, 2002.
- [7] M. Moll. "[Radiation Damage in Silicon Particle Detectors. – microscopic defects and macroscopic properties](#)", PhD Thesis, Universität Hamburg, 1999
- [8] R. Wunstorf et al. "[Investigations of donor and acceptor removal and long term annealing in silicon with different boron/phosphorus ratios](#)". Nucl. Instr. and Meth. in Phys. Res. A, 377(23):228 – 233, 1996.
- [9] D. Pitzl. "[Type inversion in silicon detectors](#)". Nucl. Instr. and Meth. in Phys. Res. A, 311(1992):98 – 104, 1992.
- [10] I. Gorelov et al. "[Electrical characteristics of silicon pixel detectors](#)", Nucl. Instrum. Meth. A 489 (2002) 202
- [11] Giulio Pellegrini. "[Technology development of 3D detectors for high energy physics and medical imaging](#)". PhD thesis, University of Glasgow, 2002
- [12] M. Lozano et al. "[Comparison of Radiation Hardness of P-in-N, N-in-N, and N-in-P Silicon Pad Detectors](#)". IEEE TRANSACTIONS ON NUCLEAR SCIENCE, VOL. 52, NO. 5, OCTOBER 2005
- [13] Ch. Broennimann et al. "[Development of an Indium bump bond process for silicon pixel detectors at PSI](#)". Nucl. Instr. and Meth. in Phys. Res. A 565 (2006) 303
- [14] S. Vaehanen. "[Emerging fine-pitch bump bonding techniques](#)". Online slides, 2010
- [15] S. Terzo on behalf of the ITk collaboration. "[Phase 2 upgrade of the ATLAS inner tracker](#)". Slides 2021
- [16] L. Anderlini et al. "[Intrinsic time resolution of 3D-trench silicon pixels for charged particle detection](#)". 2020 JINST 15 P09029
- [17] M. Amman. "[High Purity Germanium Based Radiation Detectors with Segmented Amorphous Semiconductor Electrical Contacts: Fabrication Procedures](#)"
- [18] A. Marras et al. "[Design of a Monolithic Momentum Detector using a 3D IC Vertical Integration Approach](#)". presented to the conference: "Vertically Integrated Pixel Sensors (VIPS), Pavia (Italy). April 22-24, 2010".5

# Silicon sensors basics [2]

- Signal generation:

- Particle deposits energy that produces electron-hole pairs, negative and positive charge carriers. Helped by an electric field created with an external bias voltage, carriers move and induce a current (charge change) on the electrodes. **Ramo's theorem**
- **Minimum Ionising Particle (MIP)** is a particle whose mean energy loss rate through matter is close to the minimum

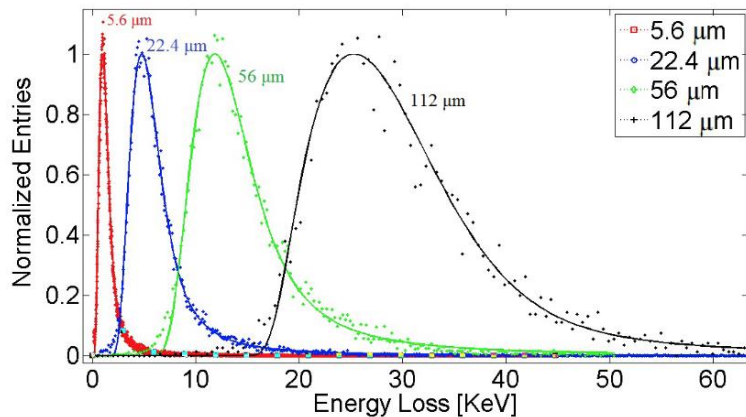

Energy loss in different silicon thicknesses, from: <https://iopscience.iop.org/article/10.1088/1748-0221/6/06/P06013/pdf>

