



Useful things to know about accelerators – part II

C. T. Rogers

ISIS

Rutherford Appleton Laboratory



**Science and
Technology
Facilities Council**



A Window on Nature

- Particle accelerators have provided unique insight into the nature of matter
 - What is matter made of?
 - What generates forces between matter?
- Culminating in the Large Hadron Collider
 - Discovery of the Higgs particle
- Many open questions remain
 - Why do different particles have such radically different masses?
 - Why are different particles sensitive to different forces?
 - Why is there so little antimatter in the universe?
 - Are there any undiscovered fundamental particles?
 - What is dark matter?



The Problem

- Exploring these questions needs bigger and bigger particle accelerators
 - Higher energy
- What limits accelerator energy?
 - Proton colliders → magnetic bending field
 - Electron linear colliders → RF accelerating field
 - Electron circular colliders → synchrotron radiation
 - Secondary particles → space charge



Magnet Technology

- Different technologies are suitable for different uses
- What field magnitude is required?
- What field shape is required? Dipole? Multipole?
- How well do we need to know the field?
- Is the magnet pulsed? What time constant?
- Cost? Maintenance? Radiation environment?
- Running costs?

Normal Conducting Magnets

- Coils provide magnetic field
 - Hollow core, water cooled
- Shaping done using iron
- Pros
 - Cheaper
 - Hands-on maintenance
- Cons
 - Field < ~ 2 T due to heating
 - Higher power consumption
 - Water leaks



Permanent Magnets

- Permanent magnets provide the magnetic field
 - Iron used to shape the field
 - Tune field by moving magnet sections
- Pros
 - No running costs
- Cons
 - Fixed field – can't pulse the magnets
 - Sensitive to radiation damage/heating
 - Limited field quality

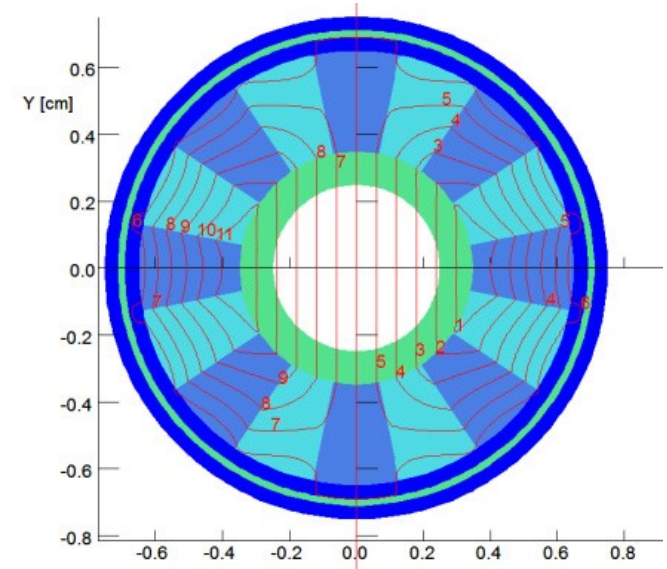

Superconducting Magnets

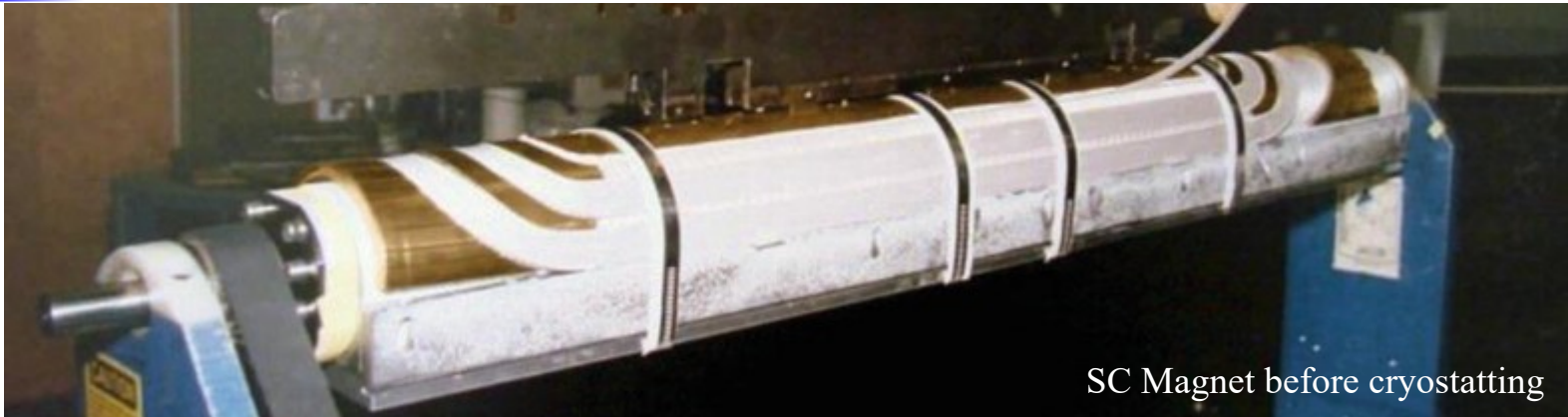

- At lHe temperature, some materials become superconducting
 - Resistivity drops to 0
- Pros
 - Can reach high fields (~ 10 T)
- Cons
 - Quench runaway process
 - heating \rightarrow increased resistivity \rightarrow more heating
 - Cryogenics management
 - Slow ramping
 - Cost



Quenches and QPS

- Quenches
 - Local heating of Helium
 - e.g. from coil movement
 - Resistivity of wire increases
 - Causes more heating of Helium
 - Runaway Process
- Quench Protection System (QPS)
 - Protect superconductor in quench
 - Detect excess resistance/voltage
 - Actively heat the superconductor
 - Extract energy through copper supports into dump resistors

Hadron Collider halted for months



Superconducting magnets are cooled down using liquid helium

The Large Hadron Collider near Geneva will be out of action for at least two months, the European Organization for Nuclear Research (Cern) says.

Part of the giant physics experiment was turned off for the weekend while engineers probed a magnet failure.

But a Cern spokesman said damage to the £3.6bn (\$6.6bn) particle accelerator was worse than anticipated.

The LHC is built to smash protons together at huge speeds, recreating conditions moments after the Big Bang.

Scientists hope it will shed light on fundamental questions in physics.

Section damaged

On Friday, a failure, known as a quench, caused around 100 of the LHC's super-cooled magnets to heat up by as much as 100 degrees.

The fire brigade were called out after a tonne of liquid helium leaked into the tunnel at Cern, near Geneva.

LHC QPS failure (2008)

Magnet quenched during ramping. Discharge current tried to enter copper busbar but weld failed. Arc across the weld caused Helium vessel to rupture leading to total failure of magnet.

As a result the entire magnet (many tonnes) moved a couple of feet. Repair to the magnet system delayed start-up for more than a year.



RF cavities

- RF cavities are resonant structures
 - Radius $\sim 2.4/\text{frequency}$
 - High frequency RF cavities are small!
- Oscillating electric field in direction of beam
 - Magnetic field azimuthally out of phase with electric field

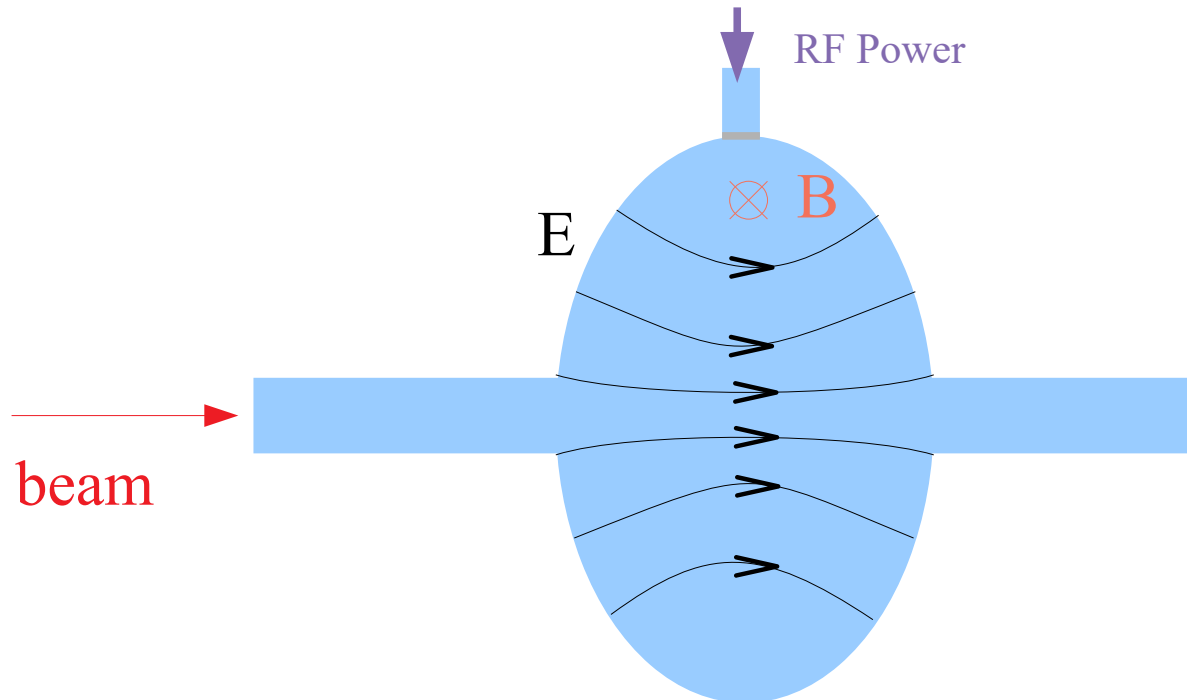



RF Cavity issues

- Damping of the resonance due to wall resistance
 - RF power → heat
 - Superconducting cavities reduce wall resistance
- Loss of power into beam limits max beam current
 - “Beam loading”
- Breakdown (spark formation) limits max voltage
 - Electric field pulls electrons from cavity surface
 - Electrons can strike cavity surface causing more sparks
 - Multipacting
 - Breakdown suppressed at higher frequencies
 - Kilpatrick limit
 - → Higher frequency cavities have higher max voltage
 - Nb: higher voltage → more cavity heating

E.g. Normal conducting 200 MHz RF

Water cooling pipes

Mounting point for frequency tuners

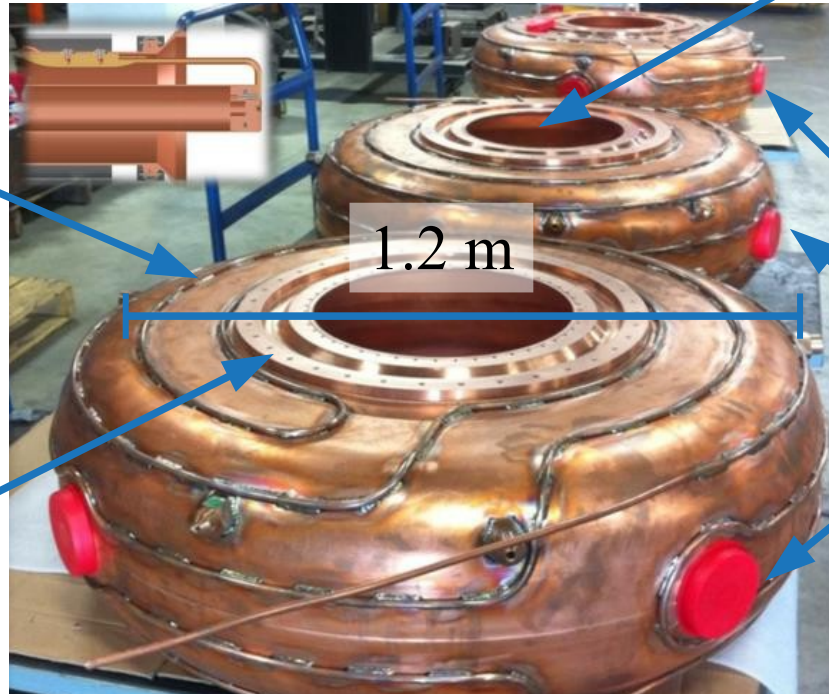

Internal surfaces treated to suppress breakdown

Ports for RF power

Superconducting 1300 MHz RF

- E.g. 1.3 GHz SCRF cavity
 - Niobium superconductor
 - Superconductor → lower losses to walls
- Peak voltage ~ 30 MV/m
 - Breakdown caused by field amplification due to surface imperfections
- Surface cleaning to improve voltage
 - Electro polishing
 - Buffer Chemical Polishing
 - Ultrapure water rinsing

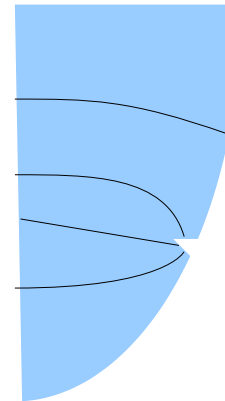

Surface imperfection
causes field amplification

Ferrite Loaded Cavity

- Semi-relativistic proton beams change velocity during acceleration
 - Can induce time-of-flight swings
 - Need to match frequency to time-of-flight
- Use ferrite-loaded cavity
 - Refractive index varies with applied B-field
 - Changes “effective” cavity size
 - Changes resonant frequency

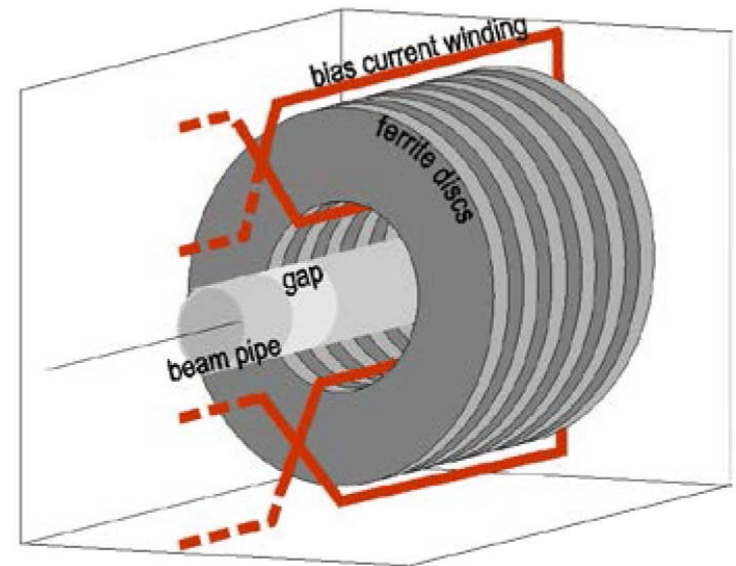



Questions?



Questions?

- You are designing a high energy proton collider ring
 - What sort of magnet would you use for the main magnets? Why?
 - What sort of RF cavity would you use? Why?
- You are designing a high current proton accelerator for neutrinos
 - What sort of magnet would you use? Why?
 - What sort of RF cavity would you use? Why?



Questions?

- You are designing a high energy proton collider ring
 - What sort of magnet would you use for the main magnets? Why?
 - High field → High momentum! Superconducting
 - What sort of RF cavity would you use? Why?
 - Long pulse → Superconducting
 - Large stored energy → 400 MHz (lower frequency)
- You are designing a high current proton ring for neutrino production
 - What sort of magnet would you use? Why?
 - Normal conducting → Robust to radiation; rapid cycling time
 - What sort of RF cavity would you use? Why?
 - Ferrite loaded → More robust to beam loading, can handle frequency swing



Types of Accelerator

- Several different types of accelerator
 - Depending on application
- Linear accelerator (linac)
 - Accelerate in a straight line
 - High current, long beam pulse applications
- Cyclotron (and FFA)
 - Accelerate through a big dipole, increasing radius
 - Rotational frequency constant for non-relativistic bunches
 - Reuse equipment → cheaper than linac
 - High current, non-relativistic
- Synchrotron
 - Ramp magnets as beam accelerated, keep radius constant
 - Rotational frequency varies → sweep RF frequency
 - Can only accelerate one pulse at a time
 - Lower current, fully relativistic



Important Parameters

- Beam energy
- Number of bunches
- Repetition rate (Rep rate)
- Storage time
- Bunch charge
- Average and peak beam power

Linear Accelerator

2017 March

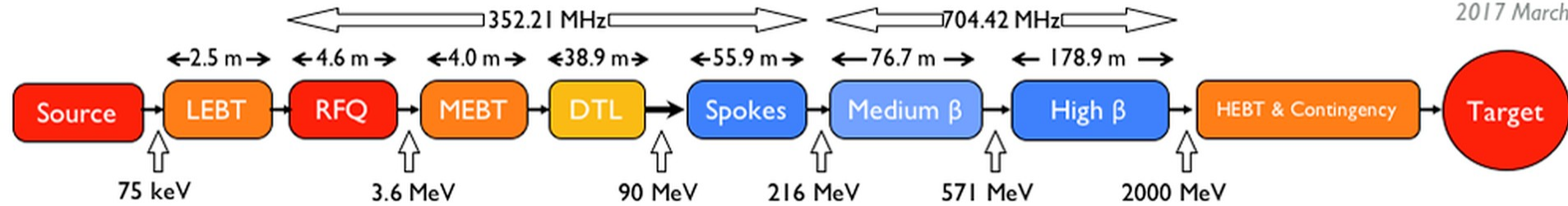

European Spallation Source (protons)

- Source
 - Protons/H⁻ ions: excited hydrogen gas
 - Electrons: heated cathode (long pulse)
 - Electrons: Laser cathode (short pulse)
- Acceleration
 - Protons/ions → non-relativistic acceleration
 - High space charge
 - Cavity phasing issues
 - High energy acceleration
- Critical issues
 - High current, high quality source
 - Control of space charge

Cyclotron

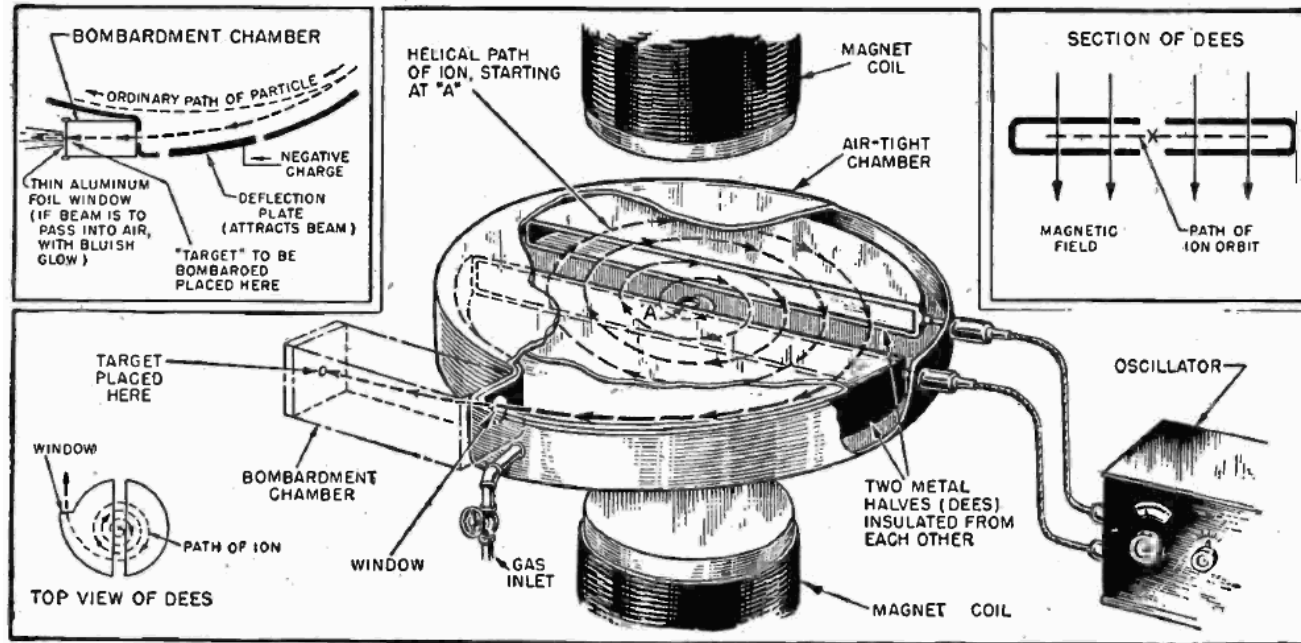

- For non-relativistic particles

- Path Length $L = 2 \pi \rho$

- Magnetic rigidity $B \rho = \frac{p}{q} = \frac{mv}{q}$

- Time of flight $t = \frac{L}{v} = \frac{2 \pi m}{q B}$

Fixed Field Alternating Gradient

- For relativistic particles
 - Vary dipole field with radius
 - Need to control tune
 - Vary RF cavity frequency in time
 - Can only accelerate a single bunch
 - Eventually the dipoles become too large
- Concept of Fixed Field Alternating Gradient accelerator “FFA”
 - Vary focussing strength proportional to momentum
 - In principle, get achromatic lattice
 - No tune variation at all
 - Large field gradient \rightarrow smaller magnets

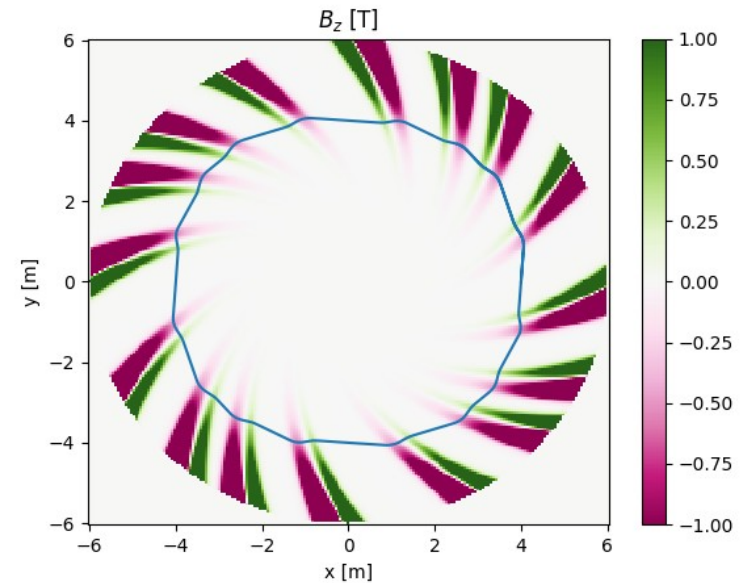



Synchrotron

- Most HEP facilities use linac followed by synchrotron
 - Linac to accelerate past space charge limit
 - Accumulate beam over a number of turns in synchrotron
 - Then ramp fields and accelerate to high energy
- Synchrotron varies magnetic field in time
 - Match bending field with beam momentum
 - Fast ramping can be quite tricky
 - Vary RF frequency and voltage to match revolution time and RF bucket size

ISIS

Neutron and Muon source

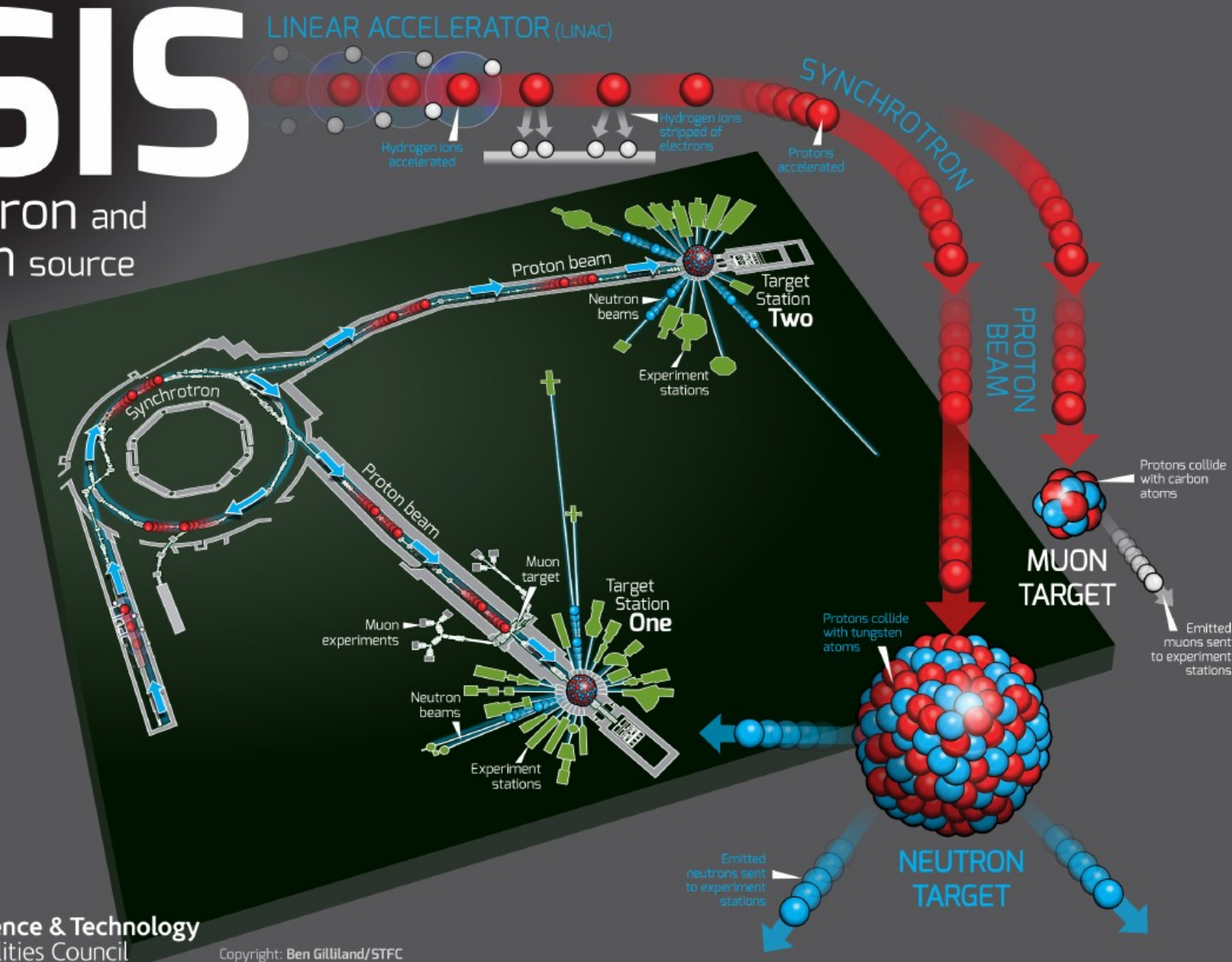

Science & Technology
Facilities Council

Copyright: Ben Gilliland/STFC



HEP Accelerator Facilities

- Proton accelerators
 - CERN complex (including LHC) – Switzerland
 - PSI – Switzerland
 - FAIR - Germany
 - Fermilab complex - US
 - J-PARC complex - Japan
- Electron accelerators
 - Super KEKB - Japan
 - DAFNE - Italy
 - BEPC II - China



Non-HEP Accelerator Facilities

- Most large accelerator facilities are not for HEP
 - Neutron and X-Ray diffraction for material studies
 - Proton and electron radiation for cancer treatment
 - Nuclear physics
- Proton/Ion accelerators – O(£Billion) facilities
 - ISIS (UK), ESS (Sweden), PSI (Switzerland), SNS (US), RHIC (US), FRIB (US), TRIUMF (Canada), JPARC (Japan), FAIR (Germany)
- Electron accelerators – O(£Billion) facilities
 - Diamond (UK), European XFEL (Germany), ESRF (France), PETRA-III (Germany), MAX-IV (Sweden), LCLS (US), SPring-8 (Japan), APS (US), CHESS (US)
- Many more...

CERN complex

CERN's Accelerator Complex

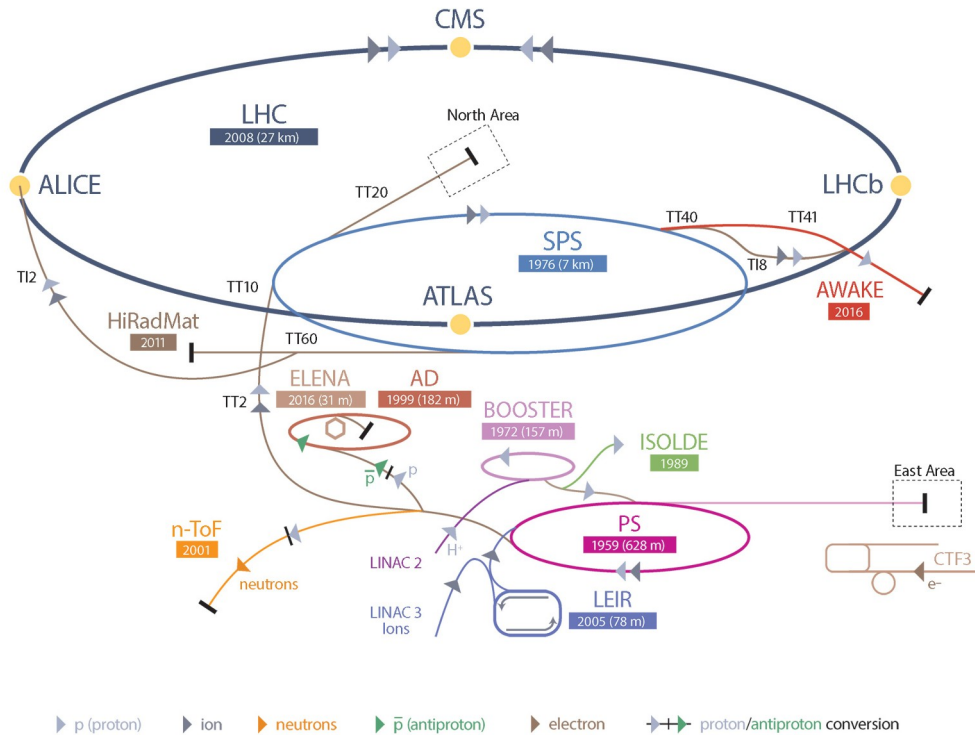

- Linac4
 - H⁻ to 160 MeV
- PSBooster
 - Charge exchange injection
 - Protons → 1.4 GeV
- PS → 25 GeV
- SPS → 450 GeV
- LHC → 6.5 TeV

HL LHC

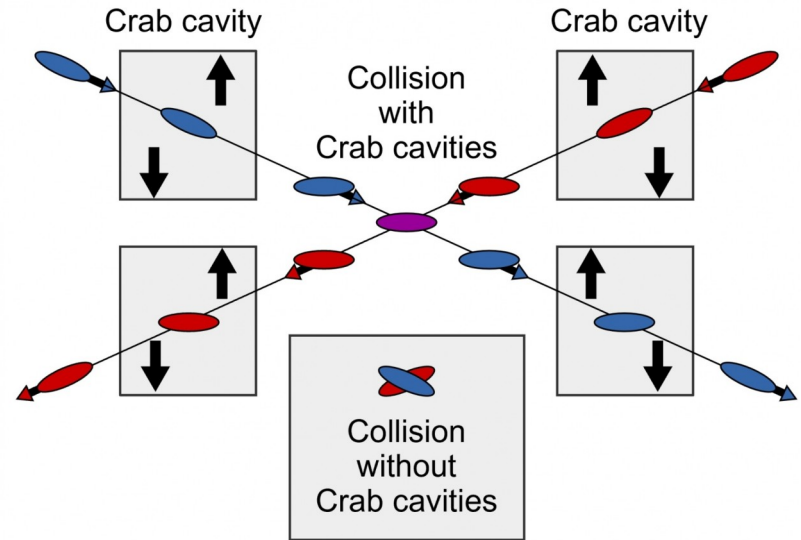
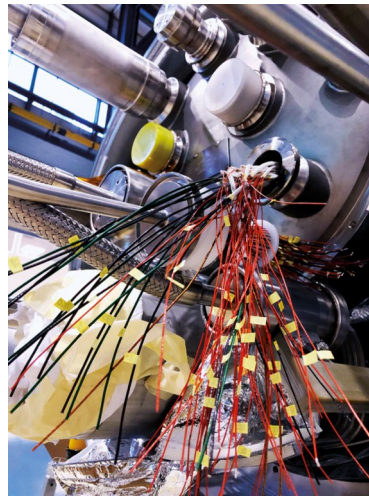
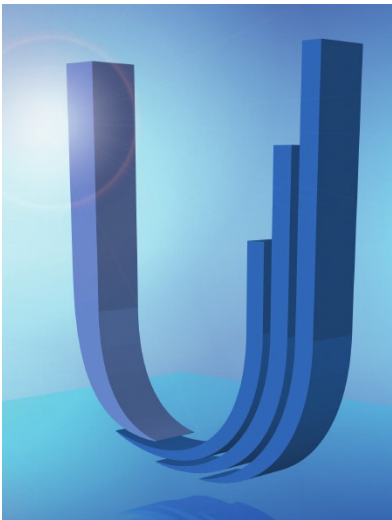
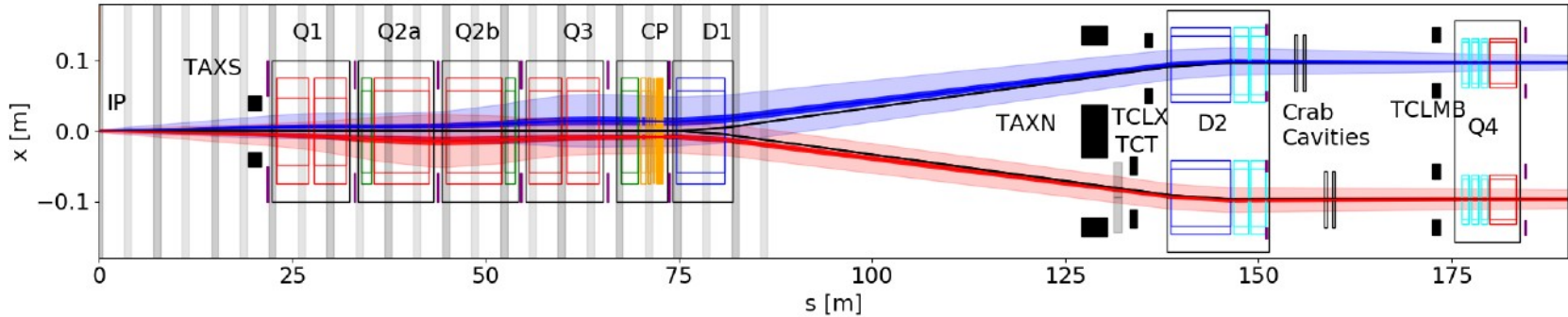

- Accelerator projects are always late and over budget
- Accelerator projects always take 5-10 years to bring to spec

Fermilab Complex

- Linac
 - H⁻ accelerated to 400 MeV
- Booster
 - Charge exchange injection
 - Acceleration to 8 GeV
 - 15 Hz rep rate
- Main Injector → 120 GeV
 - 0.8 Hz
- (Tevatron → 980 GeV)
- Upgrade plan under construction
 - 800 MeV linac

Rep rate = Number of acceleration cycles / second

Fermilab Accelerator Complex

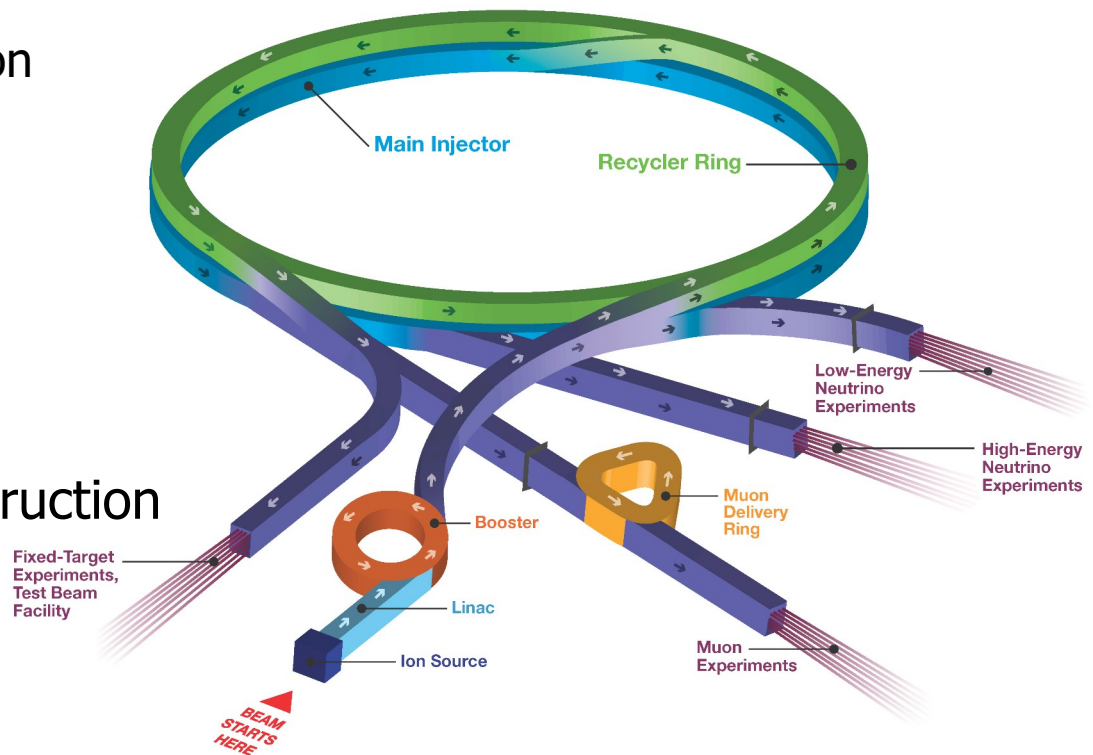

J-PARC Complex

- Linac
 - H-
 - Accelerate to 400 MeV
- Rapid Cycling Synchrotron (RCS)
 - Charge exchange injection
 - Accelerate to 3 GeV
 - 15 Hz Rep Rate
- Main Ring
 - Accelerate to 30 GeV
 - 0.3 Hz Rep Rate
- Upgrade plan
 - Double Rep Rate

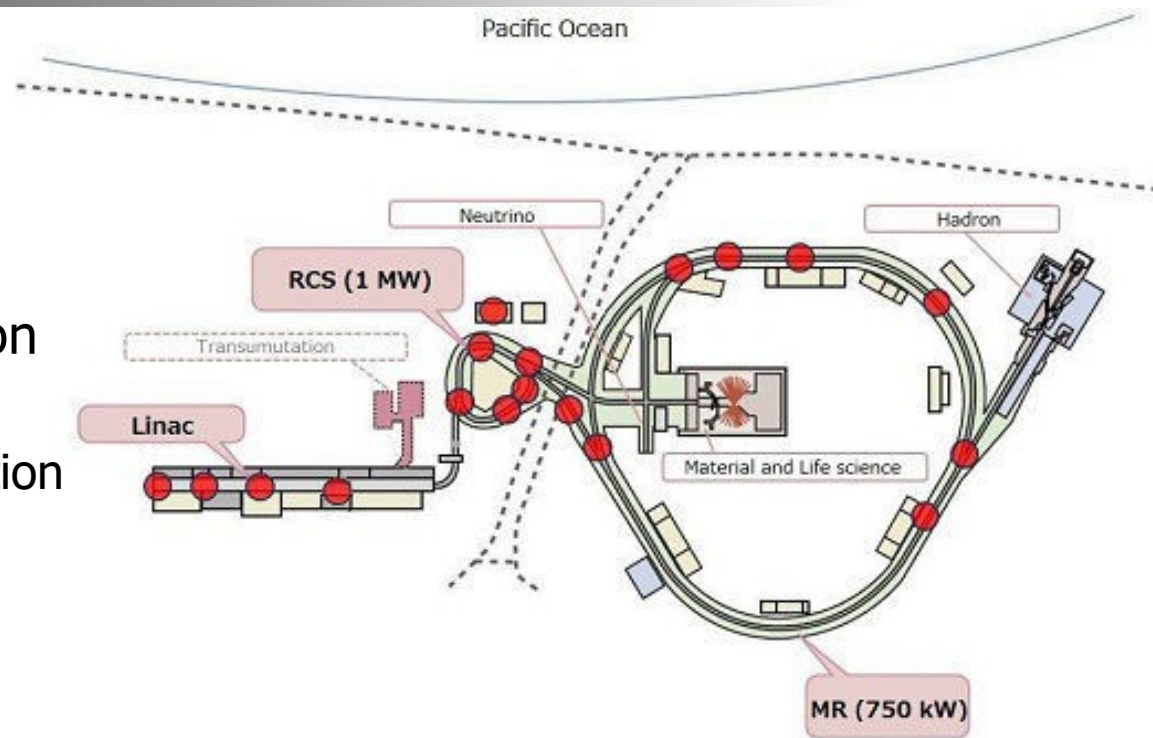

Super KEK B

- Electrons produced on photocathode
- Positrons produced by firing electrons onto target
- Positron damping ring
 - Use synchrotron radiation damping to reduce emittance
 - → Improve luminosity
- Linac
 - e^- to 7 GeV
 - e^+ to 4 GeV
- Collider ring
 - Continuously top-up the beam
 - Synchrotron radiation damping to control emittance

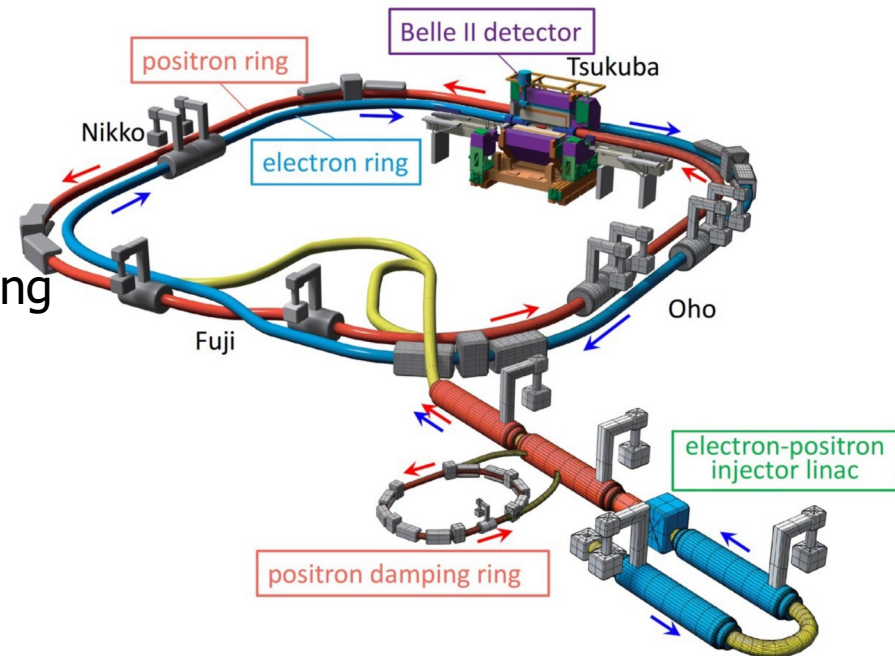



Questions?



Questions

- Why do JPARC and Fermilab have higher energy linacs vs LHC?
- Why do JPARC and Fermilab have higher rep rates vs LHC?
- What limits the rep rate of JPARC and Fermilab?
- Why do the positrons need a special damping ring at SuperKEKB



Questions

- Why do JPARC and Fermilab have higher energy linacs vs LHC?
 - Space charge limits peak current
 - High peak current → More neutrinos
- Why do JPARC and Fermilab have higher rep rates vs LHC?
 - Higher (average) current → More neutrinos
- What limits the rep rate of JPARC and Fermilab?
 - Magnet rise time
- Why do the positrons need a special damping ring at SuperKEKB?
 - Positron target makes large emittance positron beams

Future Accelerator Facilities

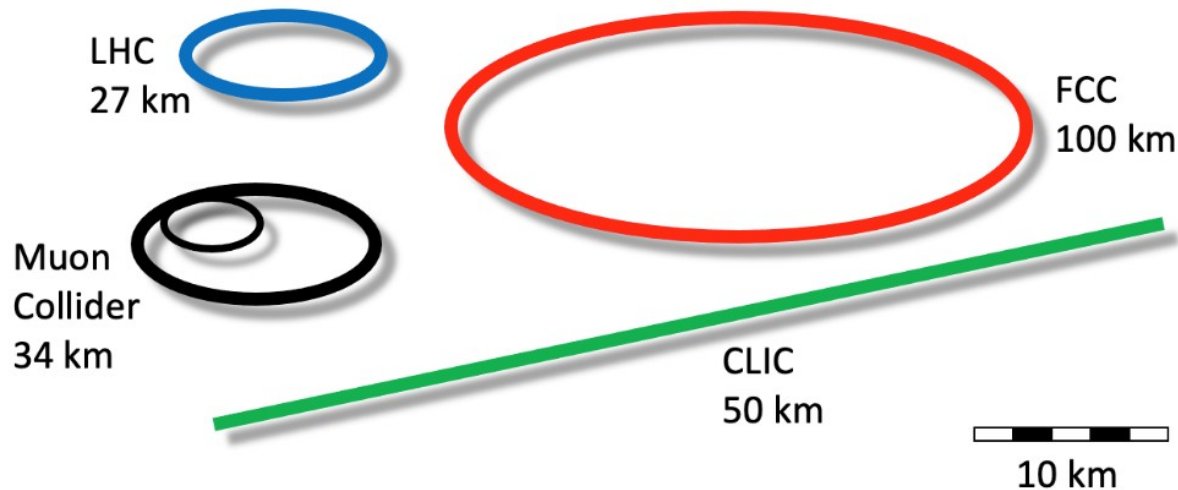

- HL-LHC will become operational ~late 2020s
 - Run for 10-20 years
 - No further upgrades possible
- Lead time for a new facility about 25 years
 - Now need to determine the next collider
 - Decisions in next ~ few years determine future of particle physics for 50-100 years



Future Collider Facilities

- FCC/CEPC
 - Up to 360 GeV electron ring collider
 - 100 TeV proton ring collider
- CLIC/ILC
 - 200 – 3000 GeV electron linac collider
- Muon collider
 - 3-14 TeV muon collider
- HALHF
 - Laser-driven e+e- linear collider
- (LEP3)
 - Important option – but I won't discuss

FCC and CEPC ee

- e^+e^- synchrotron collider
 - 360 GeV CoM energy
 - Upgrade to pp collider
 - ~90 km circumference collider ring
- Challenges
 - Huge civil engineering task
 - Management of synchrotron radiation
 - Power consumption

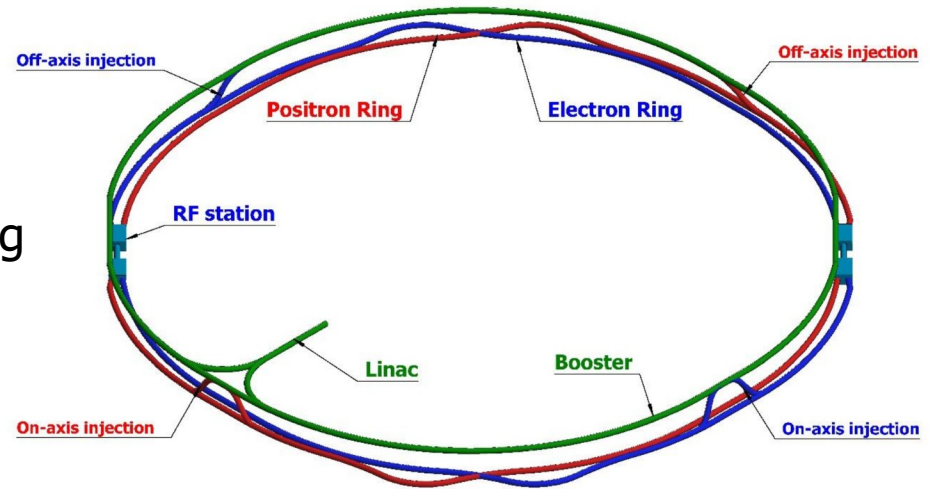

FCC-pp and SppC

- pp synchrotron collider
 - 100 TeV CoM energy
- Challenges
 - Huge number of ~ 15 T magnets
 - Cryogenic systems
 - Power requirements
 - Extraction/injection systems

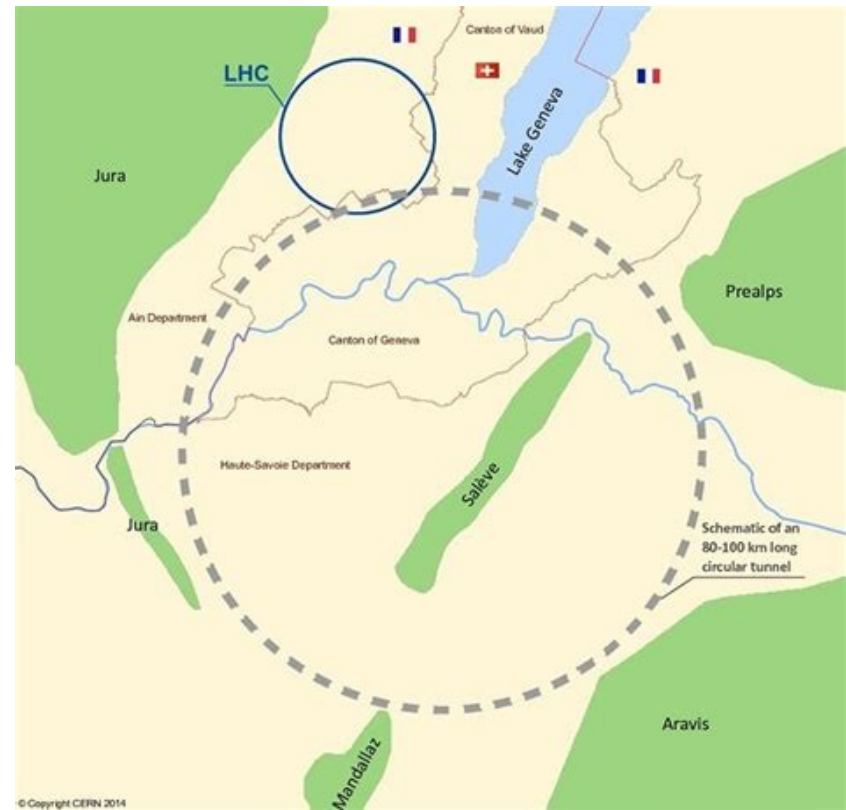

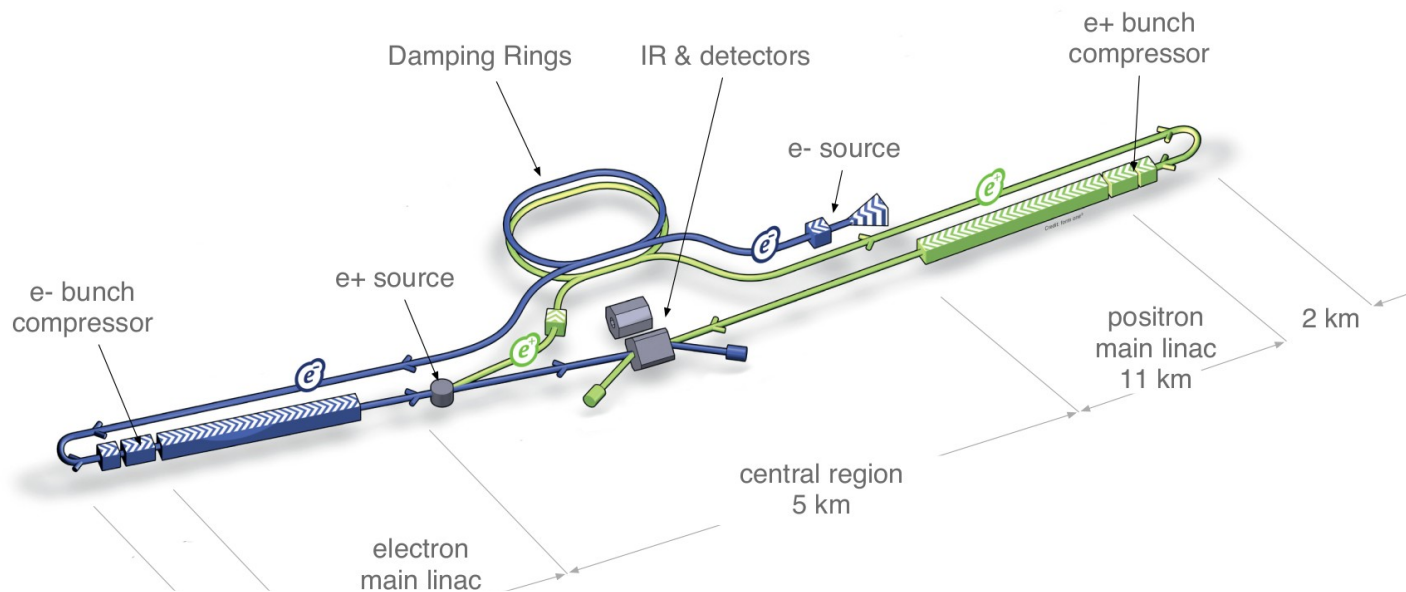

- $e^+ e^-$ linear collider
 - 200-500 GeV CoM energy
 - Potential to go to 1 TeV
- 1.3 GHz super-conducting RF (now used in many projects)
- Challenges
 - High accelerating RF gradients
 - Beam alignment
 - Electron cloud in the positron damping rings

Hybrid Asymmetric Linear Higgs Factory (HALHF)

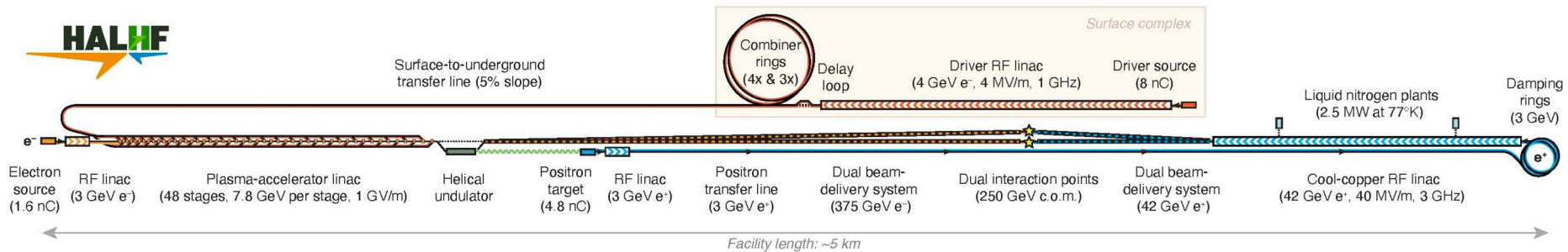

- Plasma Wakefield Acceleration (PWFA) for e⁻
 - Laser creates highly ionised plasma
 - High density regions of electrons make an E-field gradient O(GV/m)
- Conventional linear accelerator for e⁺
 - Cold copper Normal Conducting (NC) RF cavities
 - Cold copper
 - High gradient than warm NC or SC
 - Lower power consumption than warm NC
 - Gradient O(40 MV/m)

Muon collider

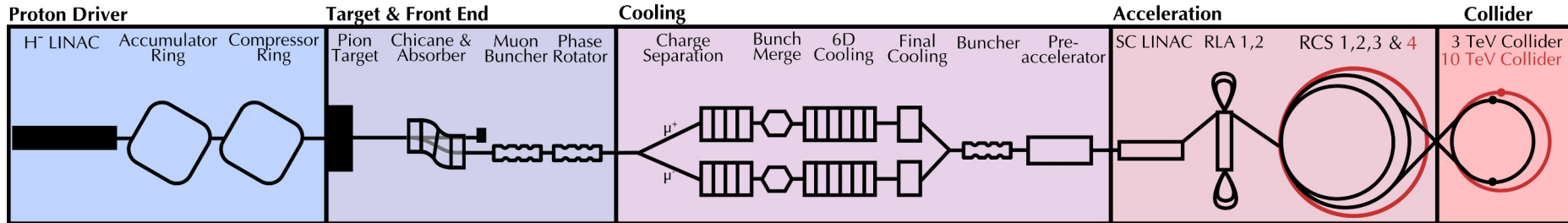

- $\mu^+\mu^-$ collider
 - 3-14 TeV CoM energy (equivalent to ~30-100 TeV protons)
- Challenges
 - Muon production and ionisation cooling
 - Rapid acceleration
 - Neutrino radiation

Bottom line

Project	Particle species	CM Energy [TeV]	Wall plug power [MW]	New Tunnel	Cost [GCHF]	Luminosity [10^{34}]
CLIC	e+e-	0.38	166	11.4	7.2	4.5
		1.5	287	29	6.5+CLIC380	3.7
C^3	e+e-	0.25	110	8		1.3
		3	320	33		14
MuC @ CERN	mu+mu-	3.2	113		12.2	0.9
		7.6	172	15	16.9	7.9
FCCee	e+e-	0.091	222	97	15.32	144
		0.365	357	97	15.32	1.45
FCChh	pp	84.6	355	97	18.9+FCCee	30
HALHF	e+e-	0.25	106	4.9	3.8	1.2
		0.55	218	8.4	6.3	2.5
LEP3	e+e-	0.091	250	0	3.2	44
		0.23	250	0	3.2	1.8
LHeC	pe-	0.05+7	220		1.6	2.3



Questions

- Why is RF a challenge for linear colliders?
- Why does the FCC-ee need such a large ring?
- Why does the FCC-hh need such a large ring?
- Why is muon capture hard?



Questions?



Questions

- Why is RF a challenge for linear colliders?
 - Getting high energy in shorted distance
- Why does the FCC-ee need such a large ring?
 - To minimise synchrotron radiation
- Why does the FCC-hh need such a large ring?
 - To minimise magnet field strength requirement
- Why is muon capture hard?
 - Muons are produced as tertiary particles
 - Muons have very short lifetime

To Conclude - Particle Colliders

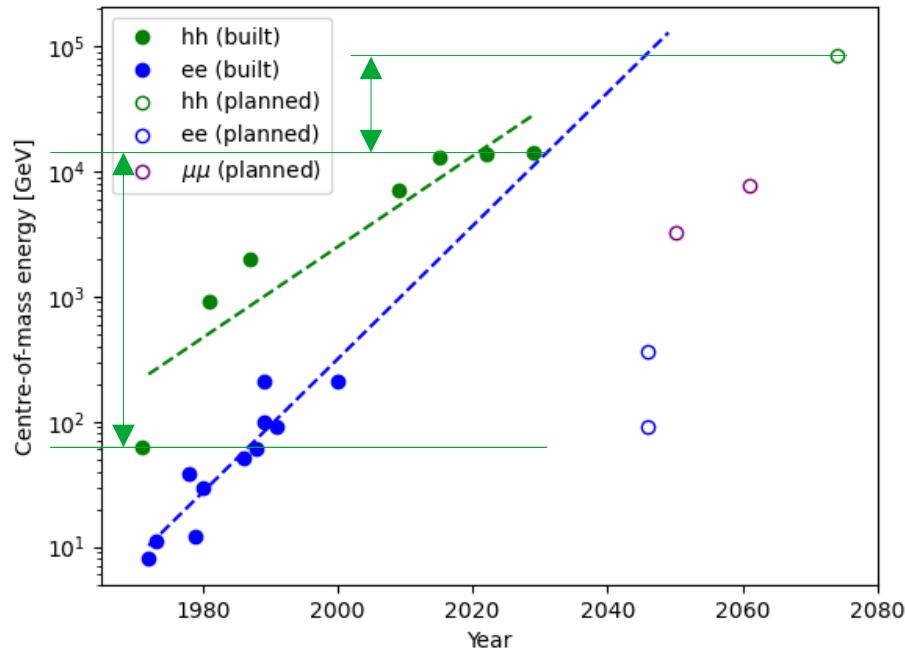

- Particle collider energy grew exponentially in 20th century
- E.g. proton collider energy grew by factor **210** in **last 50 years**
- Proton collider energy set to grow by factor **6.3** in **next 50 years**
- End of the era of exponential growth?
 - Where are the challenges
 - What are the alternatives



Conclusions

- A number of technologies involved in particle accelerators
 - Magnets
 - RF
- A number of types of accelerators
 - Linac
 - Cyclotron
 - Synchrotron
- Existing facilities
 - Deliver intense beams for secondary particle production
 - High energy beams for colliders
- Future facilities
 - Future beyond LHC
 - Pure neutrino sources

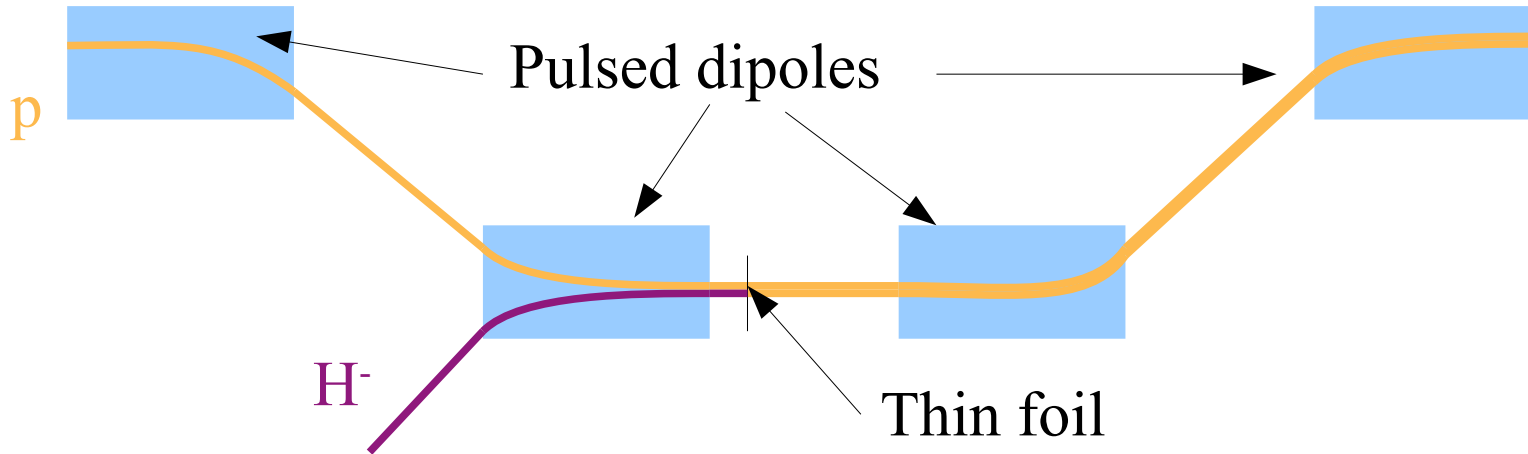

Image credits

Quadrupole coils Geek3 https://en.wikipedia.org/wiki/Quadrupole#/media/File:VFpt_quadrupole_coils_1.svg

Creative Commons license BY-SA 3.0

Charge Exchange Injection



- High current → accumulate beam over many turns
 - Charge exchange injection of H⁻ ions through a thin foil
 - Foil removes electrons
 - Issues: Scattering and energy loss of protons in foil
- Painting of beam into synchrotron acceptance using fast “bumper” magnets
 - Move recirculating beam around in horizontal and vertical phase space
 - Fill a much larger acceptance