



# NEUTRINO PHYSICS

Steve Boyd

# What's in the lectures

1. History and properties of the neutrino, neutrino interactions, beams and detectors
2. Neutrino mass, direct mass measurements, double beta decay, flavour oscillations
3. Unravelling neutrino oscillations experimentally
4. Where we are and where we're going

# Lecture 1

*In which history is unravelled, desperation is answered, and the art of neutrino generation and detection explained*

# Crisis

It is 1914 - the new field of atomic physics is in trouble

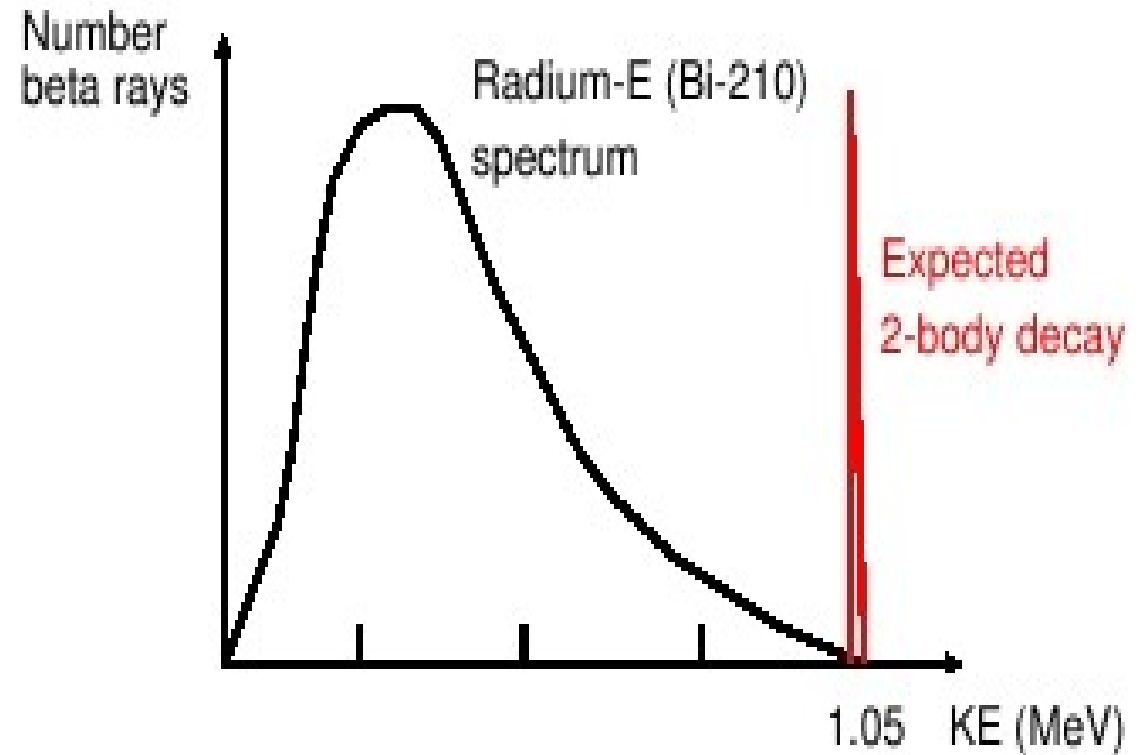
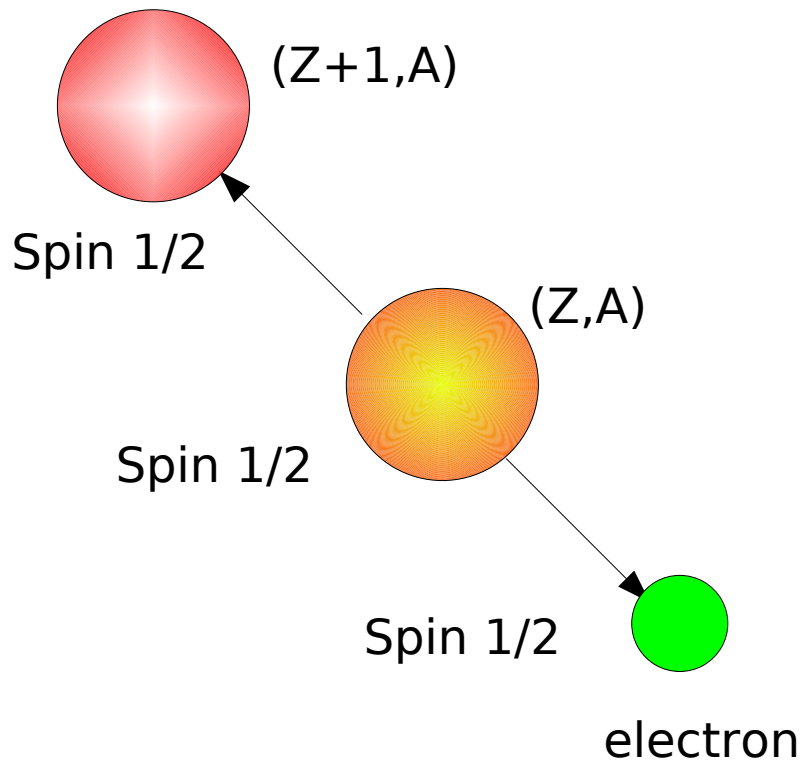

$$\text{Spin } \frac{1}{2} \neq \text{spin } \frac{1}{2} + \text{spin } \frac{1}{2}$$

$$E_{\text{Ra}} \neq E_{\text{Bi}} + e$$



“At the present stage of atomic theory we have no arguments for upholding the concept of energy balance in the case of  $\beta$ -ray disintegrations.”



“Desperate remedy.....”  
“I do not dare publish this idea....”  
“I admit my way out may look improbable....”  
“Weigh it and pass sentence....”

“You tell them. I'm off to a party”

4th December 1930

Dear Radioactive Ladies and Gentlemen,

As the bearer of these lines, to whom I graciously ask you to listen, will explain to you in more detail, how because of the "wrong" statistics of the N and  ${}^6\text{Li}$  nuclei and the continuous beta spectrum, *I have hit upon a desperate remedy to save the "exchange theorem" of statistics and the law of conservation of energy.* Namely, the possibility that *there could exist in the nuclei electrically neutral particles, that I wish to call **neutrons**, which have spin and obey the exclusion principle* and which further differ from light quanta in that they do not travel with the velocity of light. The *mass* of the neutrons *should be of the same order of magnitude as the electron mass* (and in any event not larger than 0.01 proton masses). The continuous beta spectrum would then become understandable by the assumption that in beta decay a neutron is emitted in addition to the electron such that the sum of the energies of the neutron and the electron is constant...

From now on, every solution to the issue must be discussed. Thus, dear radioactive people, look and judge. *Unfortunately I will not be able to appear in Tübingen personally, because I am indispensable here due to a ball which will take place in Zurich during the night from December 6 to 7...*

Your humble servant,  
W. Pauli

# Oh the pain

*“I have done something very bad today by proposing a particle that cannot be detected. It is something that no theorist should ever do.”*

*Pauli, 1930*

# Detection of the Neutrino

1950 – Reines and Cowan set out to detect  $\nu$

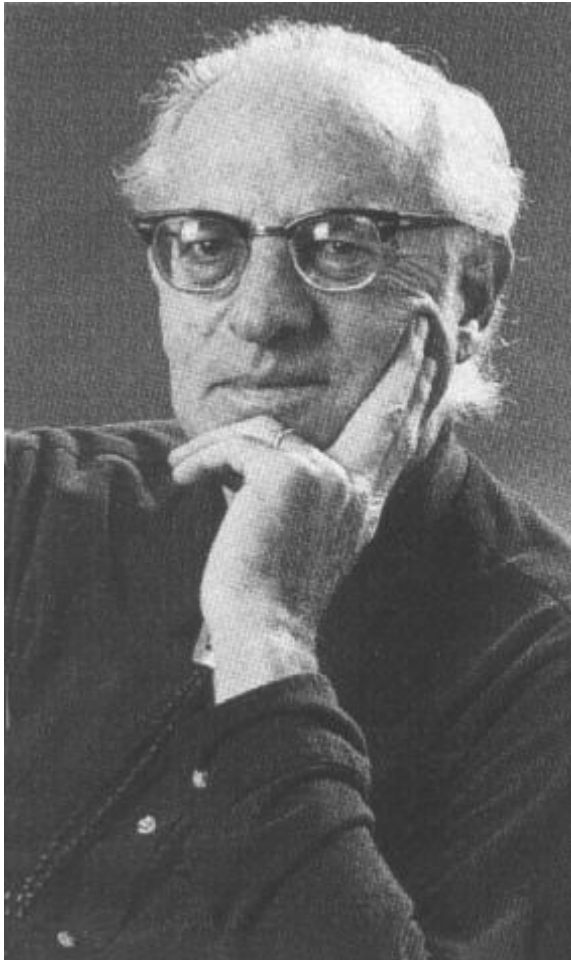

# Detection of the Neutrino

1953-1956

## The Reines-Cowan Experiments

*Detecting the Poltergeist*



Hanford Team 1953

## Savannah Team 1955



The Hanford Team: (on facing page, left to right, back row) F. Newton Hayes, Captain W. A. Walker, T. J. White, Fred Reines, E. C. Anderson, Clyde Cowan, Jr., and Robert Schuch (inset); not all team members are pictured.

The Savannah River Team: (clockwise, from lower left foreground) Clyde Cowan, Jr., F. B. Harrison, Austin McGuire, Fred Reines, and Martin Warren; (left to right, front row) Richard Jones, Forrest Rice, and Herald Kruse.

In 1951, when Fred Reines first contemplated an experiment to detect the neutrino, this particle was still a poltergeist, a fleeting yet haunting ghost in the world of physical reality. All its properties had been deduced but only theoretically. Its role was to carry away the missing energy and angular momentum in nuclear beta

decay, the most familiar and widespread manifestation of what is now called the weak force. The neutrino surely had to exist. But someone had to demonstrate its reality. The relentless quest that led to the detection of the neutrino started with an energy crisis in the very young field of nuclear physics.

# 1951

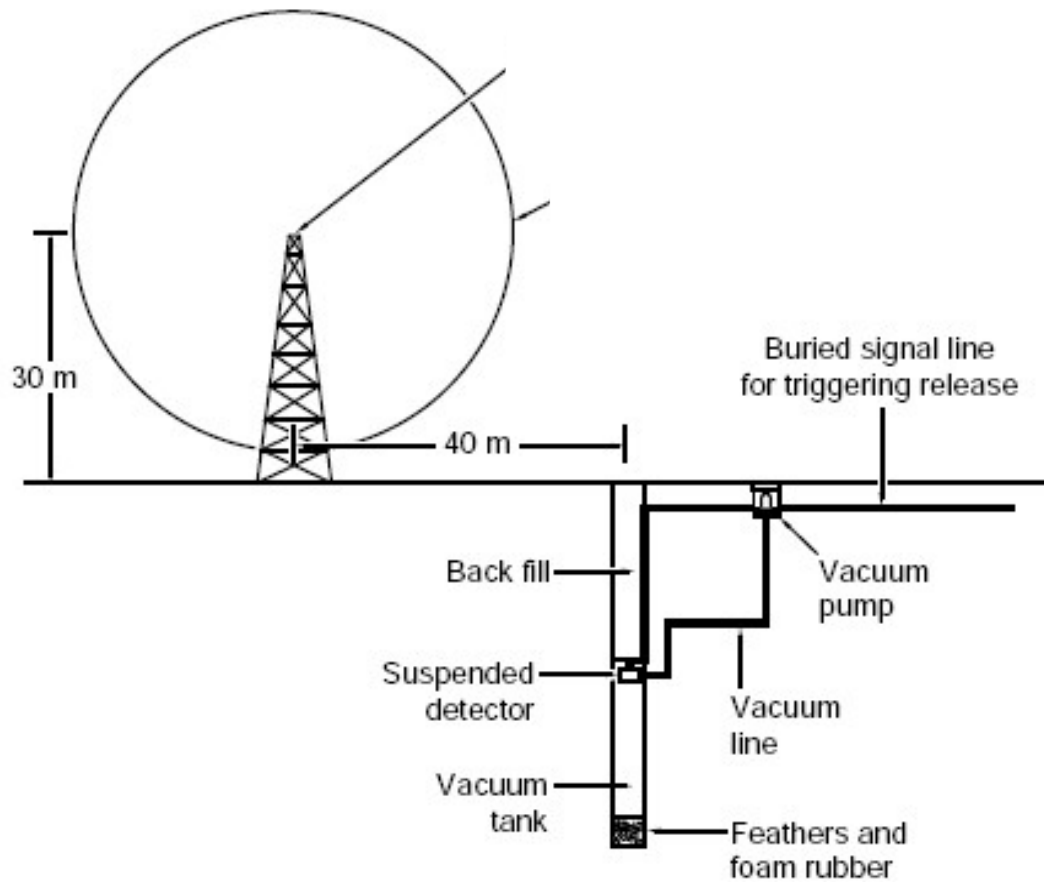

# 1951

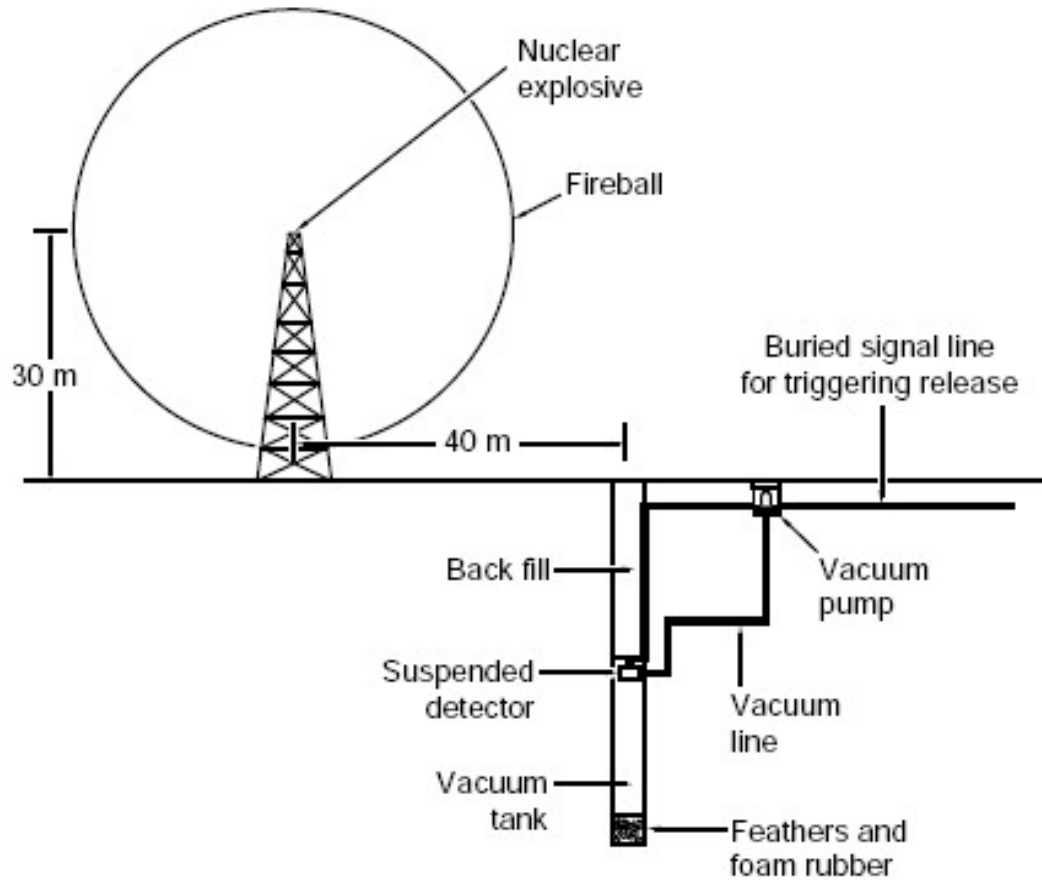

# 1951

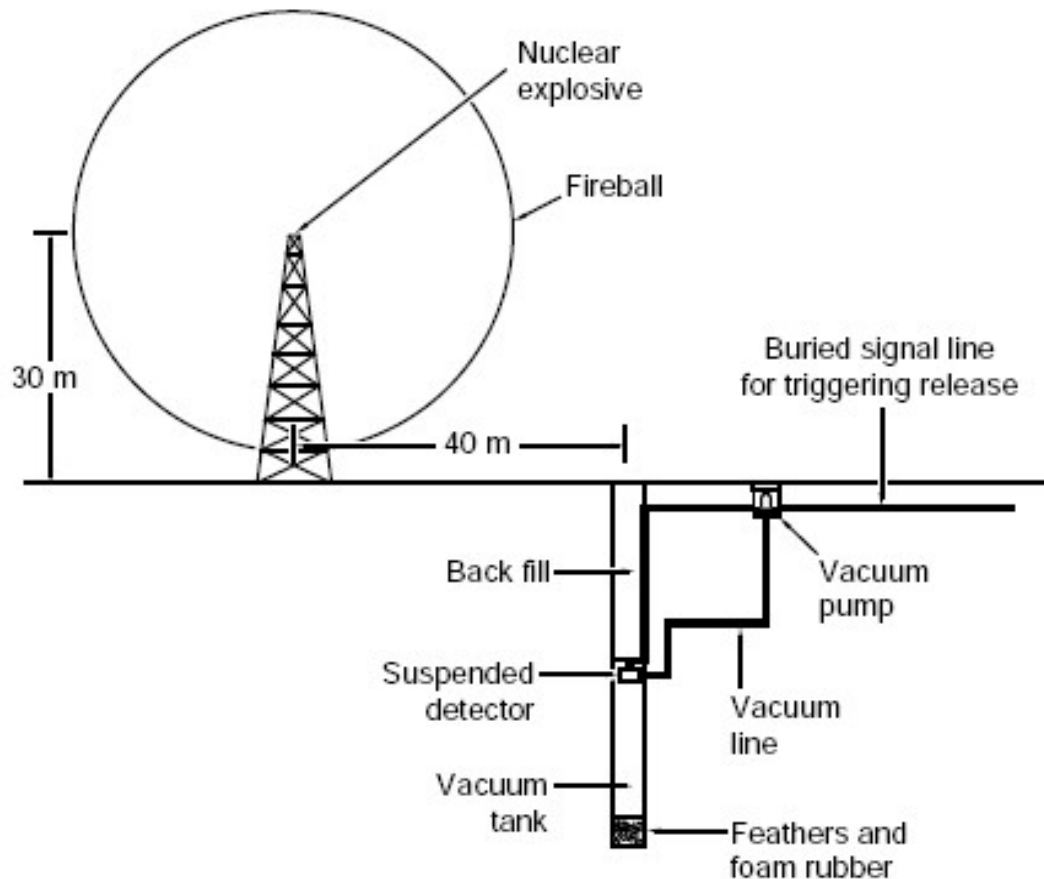

- I. Explode bomb
- II. At same time let detector fall in vacuum tank
- III. Detect neutrinos
- IV. Collect Nobel prize

OK - but repeatability is a bit of a problem

# Idea Number 2 - 1955

A nuclear reactor is the next best thing

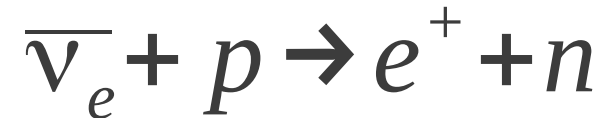

## Positron Annihilation

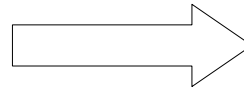
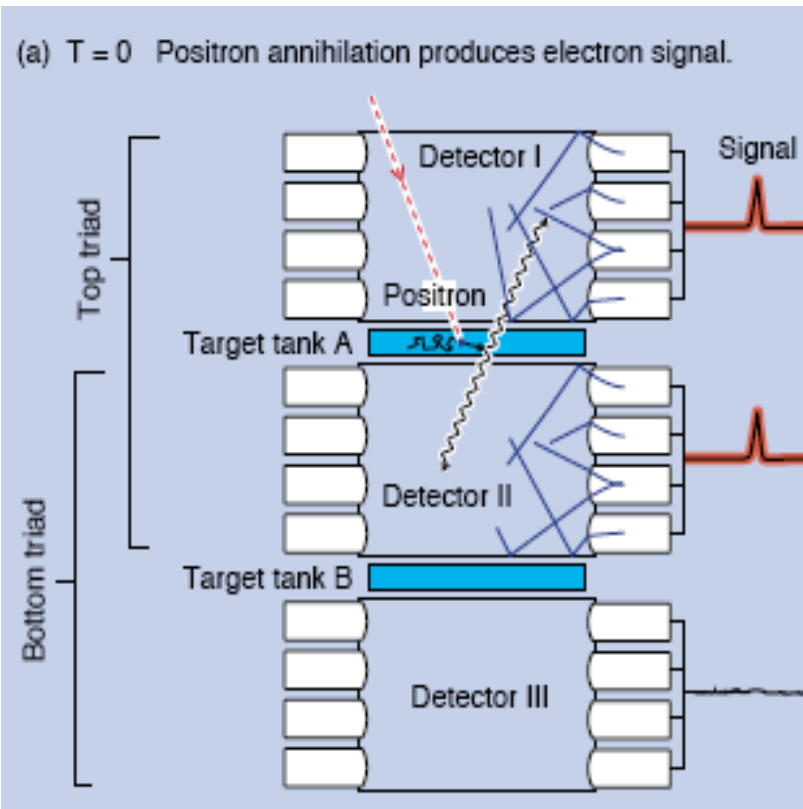

## Neutron Capture

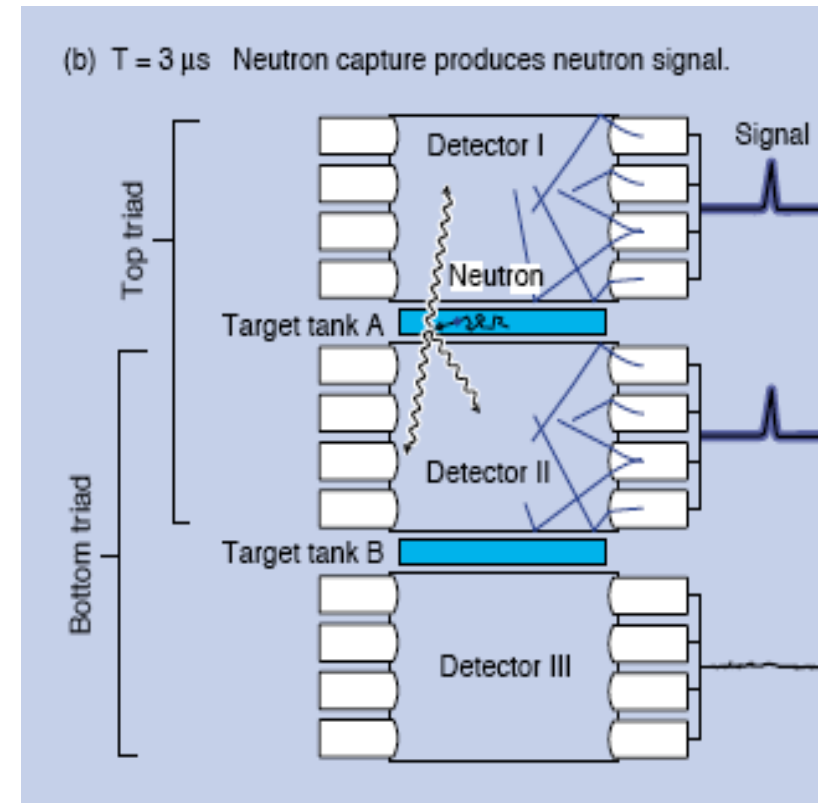



# 1959 – Savannah River Reactor

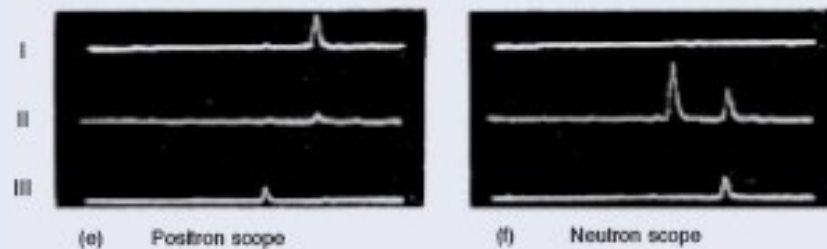
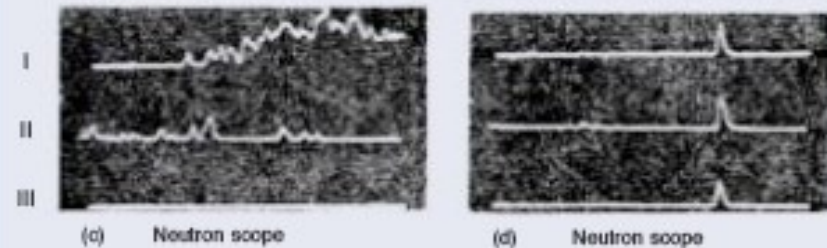
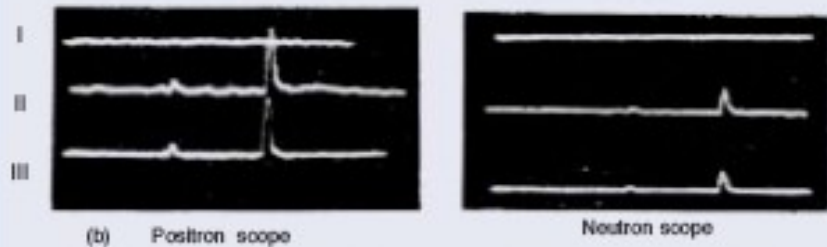
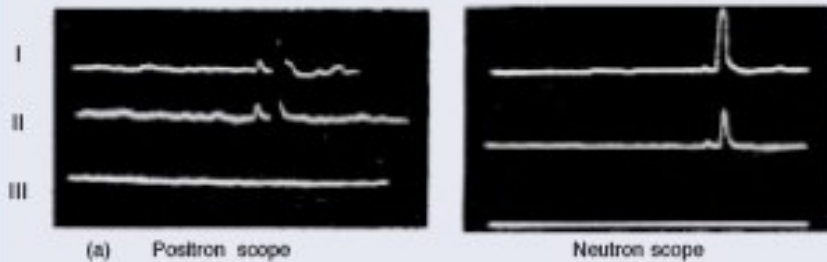

$$\text{ON} - \text{OFF} = 2.88 \pm 0.22 \text{ hr}^{-1}$$

$$\sigma = (11 \pm 2.6) \times 10^{-44} \text{ cm}^2$$

$$\sigma (\text{Pred}) = (5 \pm 1) \times 10^{-44} \text{ cm}^2$$

# Neutrinos come in flavours!

Up to 1962, only the electron neutrino had been detected – and hence only the “neutrino” existed.

Suspensions were strong that more were out there

In 1962, Schwartz, Steinberger and Lederman presented evidence for the muon neutrino and built the very first neutrino beam!

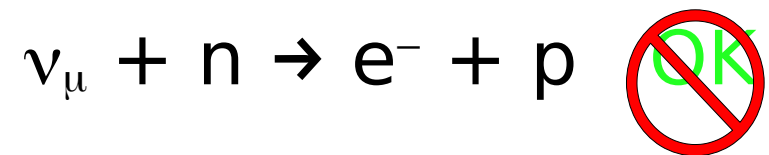
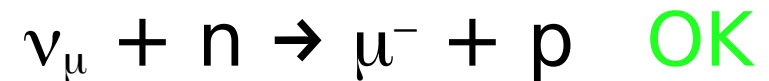
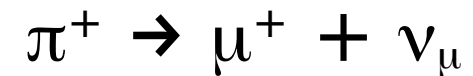
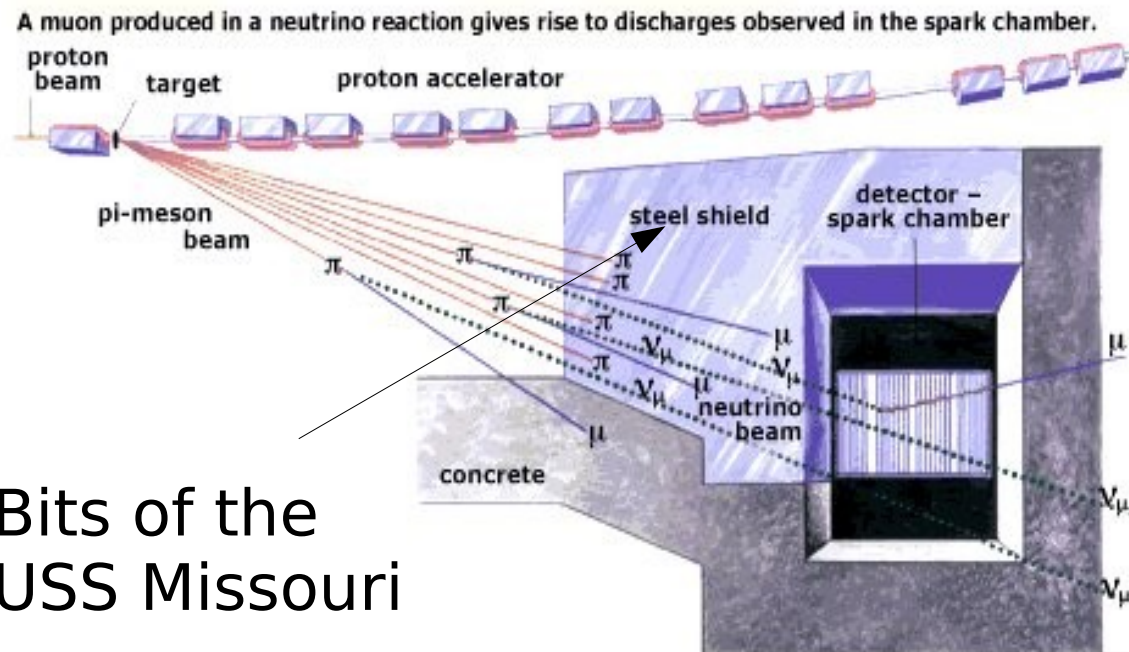

Bits of the  
USS Missouri

# The State of Play pre-2000

Flavour	Mass (GeV/c <sup>2</sup> )	Electric Charge
$\nu_e$	$< 1 \times 10^{-8}$	0
electron	0.000511	-1
$\nu_\mu$	$< 0.0002$	0
muon	0.106	-1
	?	
tau	1.7771	-1

How many neutrinos do we expect to find?

# The Number of light neutrinos

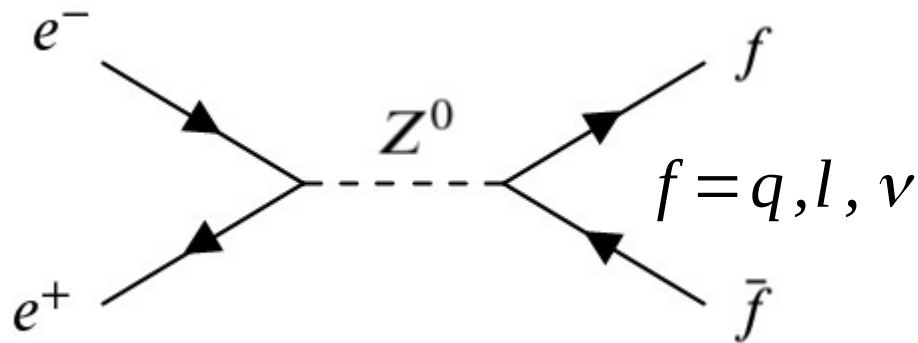

$$\Gamma_Z = \sum \Gamma_{q\bar{q}} + 3\Gamma_{l\bar{l}} + N_\nu \Gamma_{\nu\bar{\nu}}$$

Discovery of  $Z^0$  allowed a measurement of the number of light neutrinos since the  $Z^0$  can decay to a neutrino and antineutrino

NB Mass of  $\nu < m_Z/2 \sim 46$  GeV

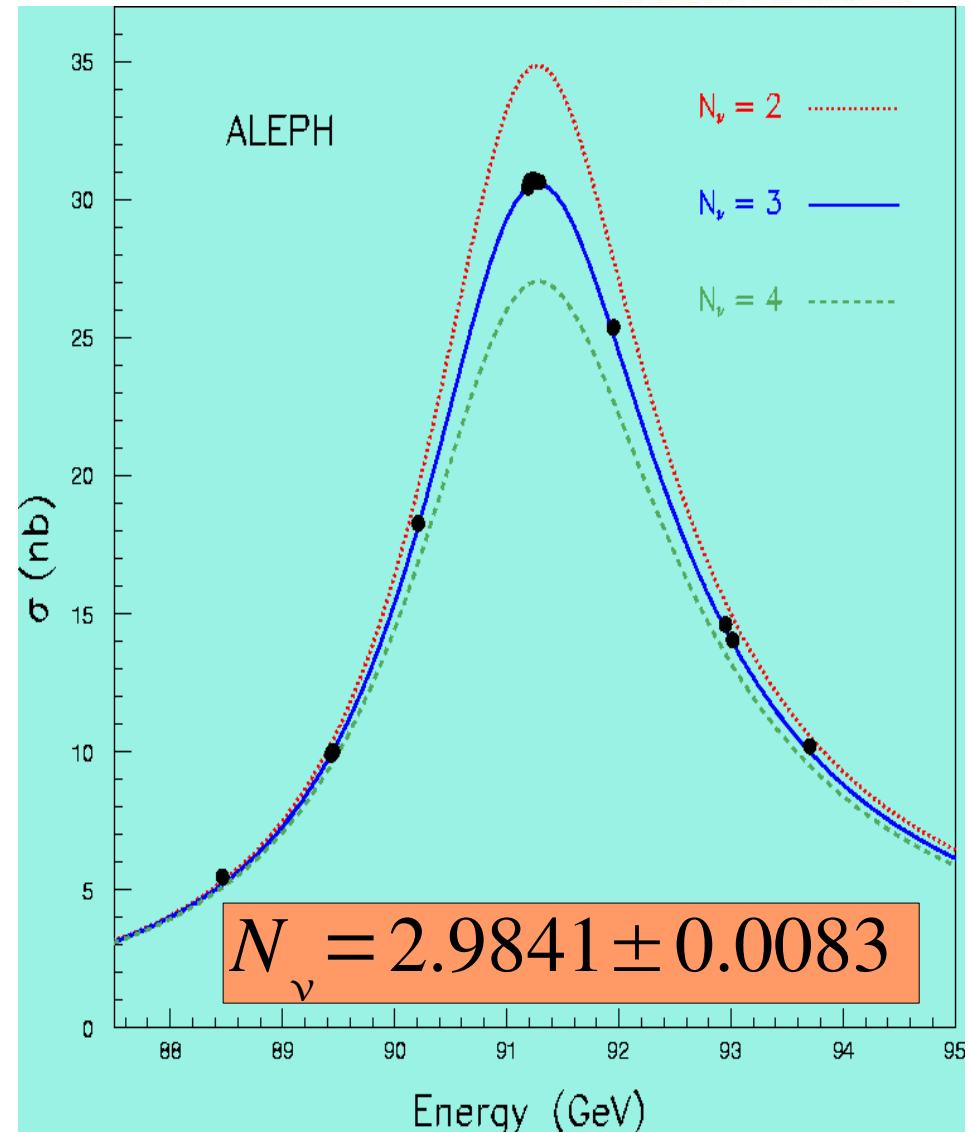

# The Tau Neutrino

$\nu_\tau$  was finally discovered by DONUT in 2000.

800 GeV protons on  
Tungsten produce  
 $D_s (=c\bar{s})$  mesons

$$D_s \rightarrow \tau + \nu_\tau$$

$$\nu_\tau + N \rightarrow \tau + X$$

$$\tau \rightarrow \mu + \nu_\tau + \bar{\nu}_\mu$$

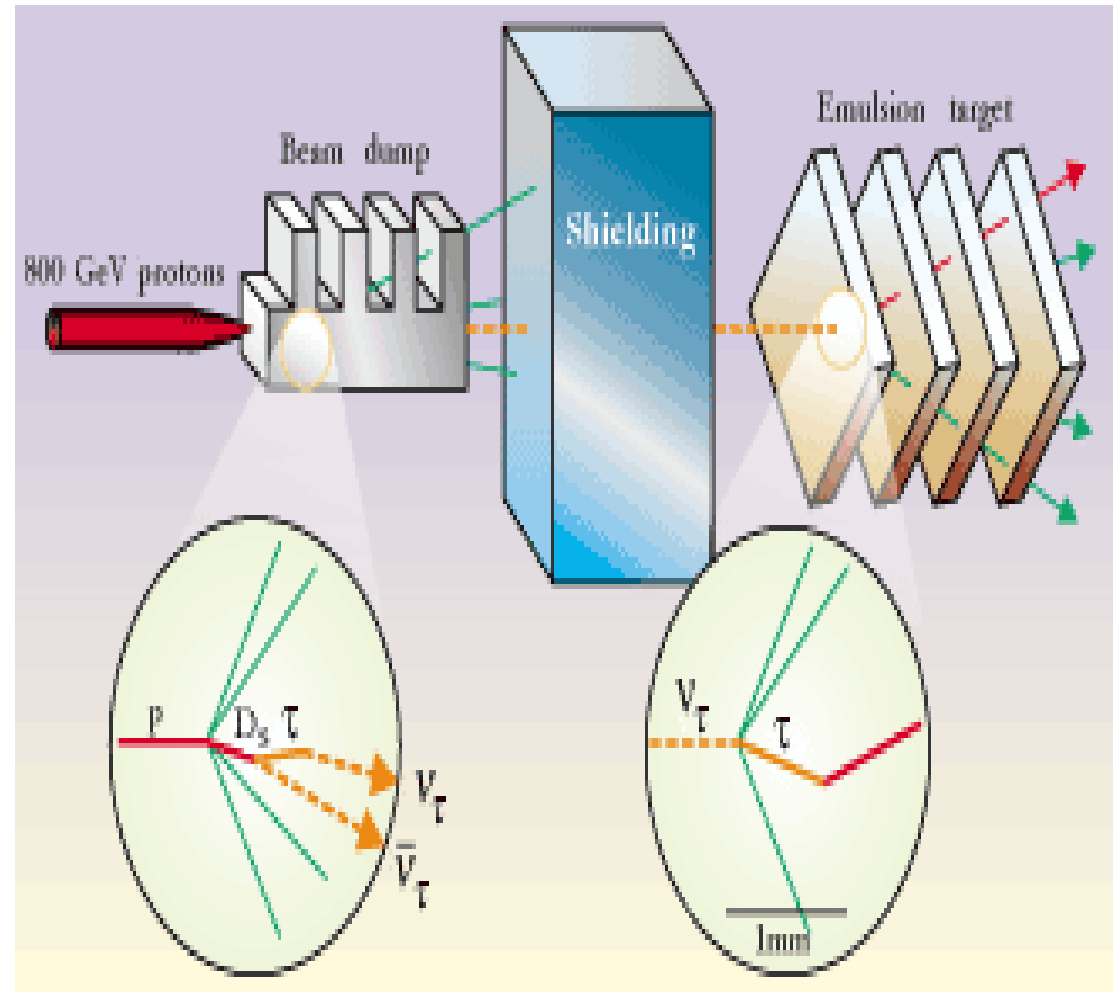

# Discovery of the $\nu_\tau$

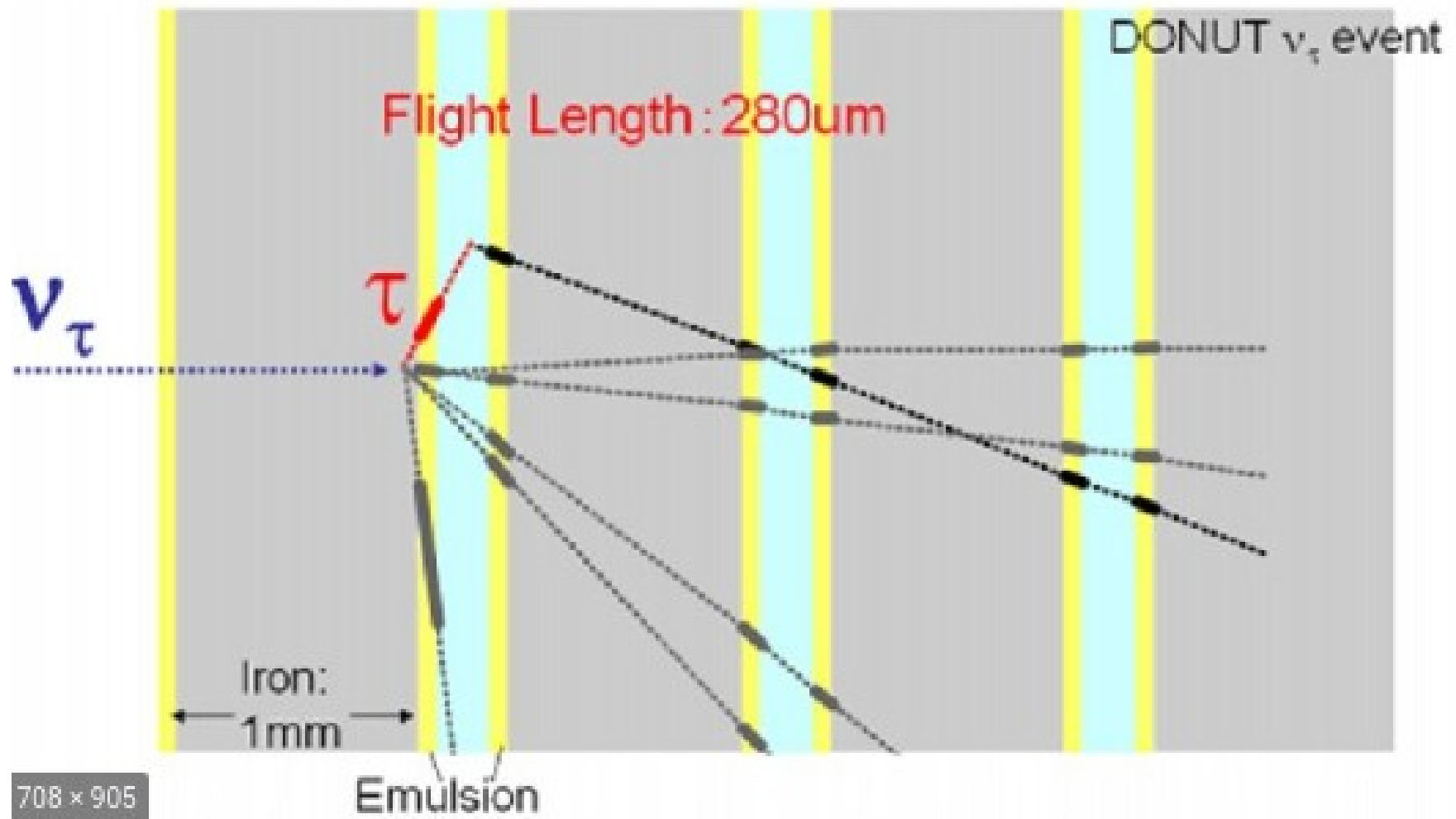

# Helicity and Chirality

Neutrinos only interact weakly through a V-A interaction  
If Neutrinos are massless then

$\nu$  : LH Chiral and LH helical

$\bar{\nu}$  : RH Chiral and RH helical

Because of ***production***

If Neutrinos have mass then

It is possible to observe a LH chiral neutrino with *right-handed* helicity (but NOT RH chirality)

$$P(\text{"wrong-sign" helicity}) \propto (m/E)^2$$

# Neutrino Properties

- Electrically neutral and interact only via the weak interaction.
- spin  $1/2$
- (anti)neutrinos are chirally left(right)-handed (but can be helically right(left)-handed if massive)
- Exist in (at least) 3 active flavours
- Are almost massless
- Are the most common fermions in the universe
- Is a neutrino its own anti-particle (Majorana particle)?
- Are there sterile neutrinos?
- What is the absolute neutrino mass?
- Is there CP violation in the neutrino sector?
- Does the neutrino have a magnetic moment?
- Are they stable?

# Neutrino Properties

- Electrically neutral and interact only via the weak interaction.
- spin  $1/2$
- (anti)neutrinos are chirally left(right)-handed (but can be helically right(left)-handed if massive)
- Exist in (at least) 3 active flavours
- Are almost massless
- Are the most common fermions in the universe
- Is a neutrino its own anti-particle (Majorana particle)?
- Are there sterile neutrinos?
- What is the absolute neutrino mass?
- Is there CP violation in the neutrino sector?
- Does the neutrino have a magnetic moment?
- Are they stable?

**Break!**

# Making Neutrinos

# Neutrino experiments are hard!

*“..in an ordinary way I might say that I do not believe in neutrinos. Dare I say that experimental physicists will not have sufficient ingenuity to make neutrinos”*

*Sir Arthur Eddington*

# How to make a neutrino beam

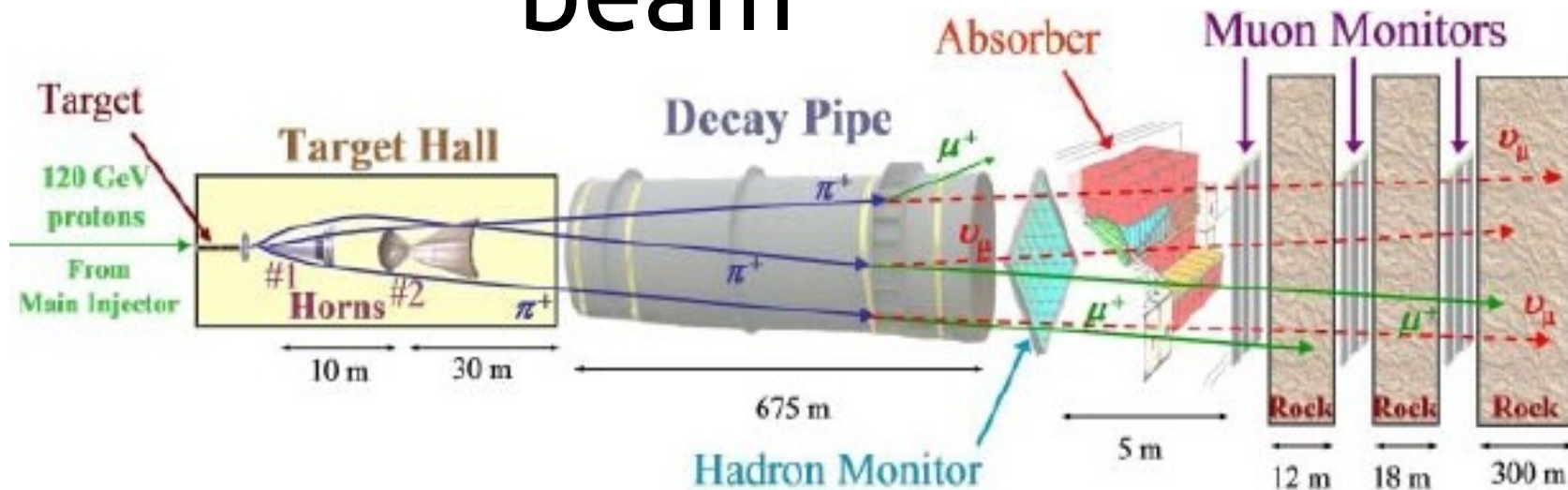

protons

$\pi/K$

$\mu, \pi, K, \nu_e, \nu_\mu$

$\nu_\mu, \nu_e$

- Each part of the beamline must be designed with many tradeoffs in mind
- Major uncertainty in beam is the production of  $\pi/K$  in  $p$ -target interactions
- Total flux uncertainties  $\sim 20\%$

# Proton Beam

- Number of pions  $\propto$  total number of protons on target (POT) times proton energy
- The higher energy neutrino beam you want, the higher energy proton beam you need.

Source	p Energy (GeV)	p/year	Power (MW)	Neutrino Energy
FNAL Booster	8	5.0E+20	0.05	1
FNAL Main Injector	120	2.5E+20	0.25	3.0-17.0
CNGS (CERN)	400	4.5E+19	0.12	0.0-40.0
<i>LBNF (Fermilab)**</i>	<i>60 / 120</i>	<i>1.90E+21</i>	<i>1.2</i>	<i>0.5 – 10.0</i>
<i>J-PARC Upgrade**</i>	<i>30</i>	<i>1.60E+22</i>	<i>1.5</i>	<i>0.6</i>

\*\*Design parameters – beams still under construction

# Targetry

Have to balance competing needs

- The longer the target, the higher the probability that a proton will interact (☺)
- But more secondary particles will scatter (☹)
- The more protons interact the hotter the target will get (☹)
- The wider the target the cooler it is (☺) but more material to scatter secondaries (☹)

Low Z material (C, Be, Al) for heat properties

Usually around 50 cm to 1 m long

In small segments so that heating won't break the entire thing

Cooling systems needed (air, water, liquid helium)

# Targetry

3.3E14 ppp w/ 5 $\mu$ s pulse

When this beam hits an iron block,

beam spot  
dose rate

> 1000Sv/h

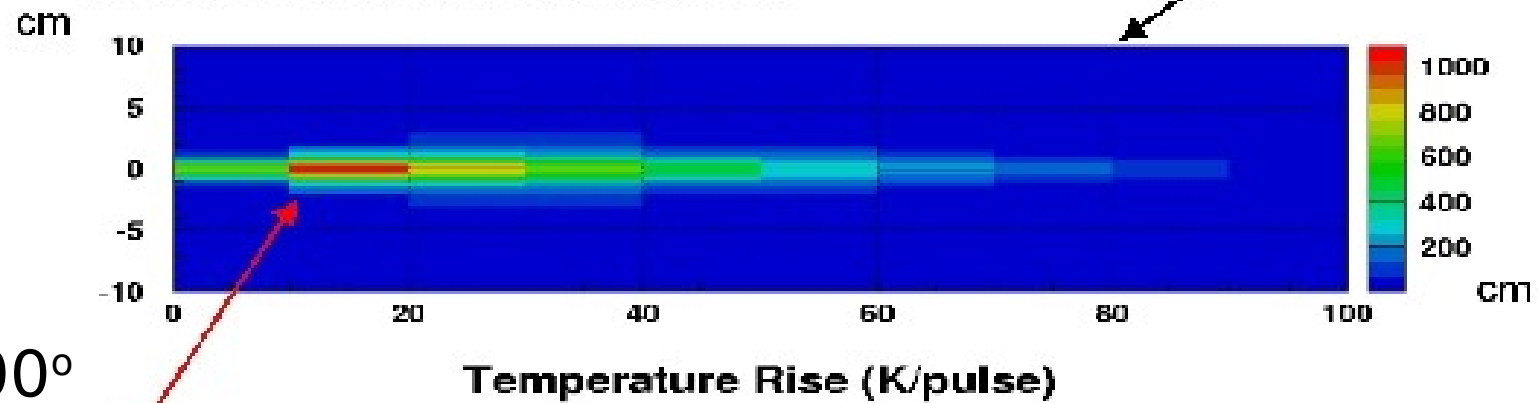

1100°



# Target Infrastructure

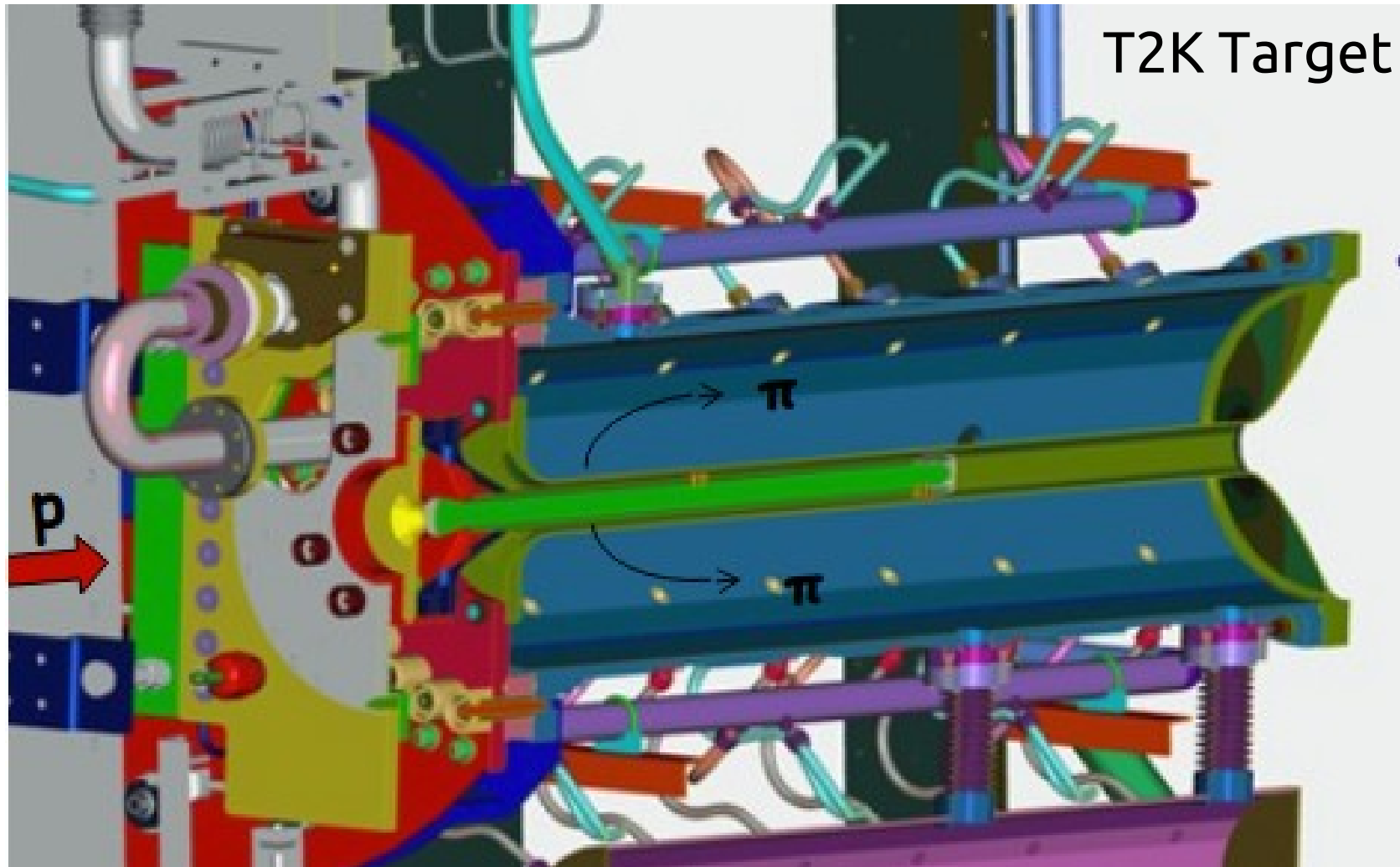

# Basics of Horn Focussing

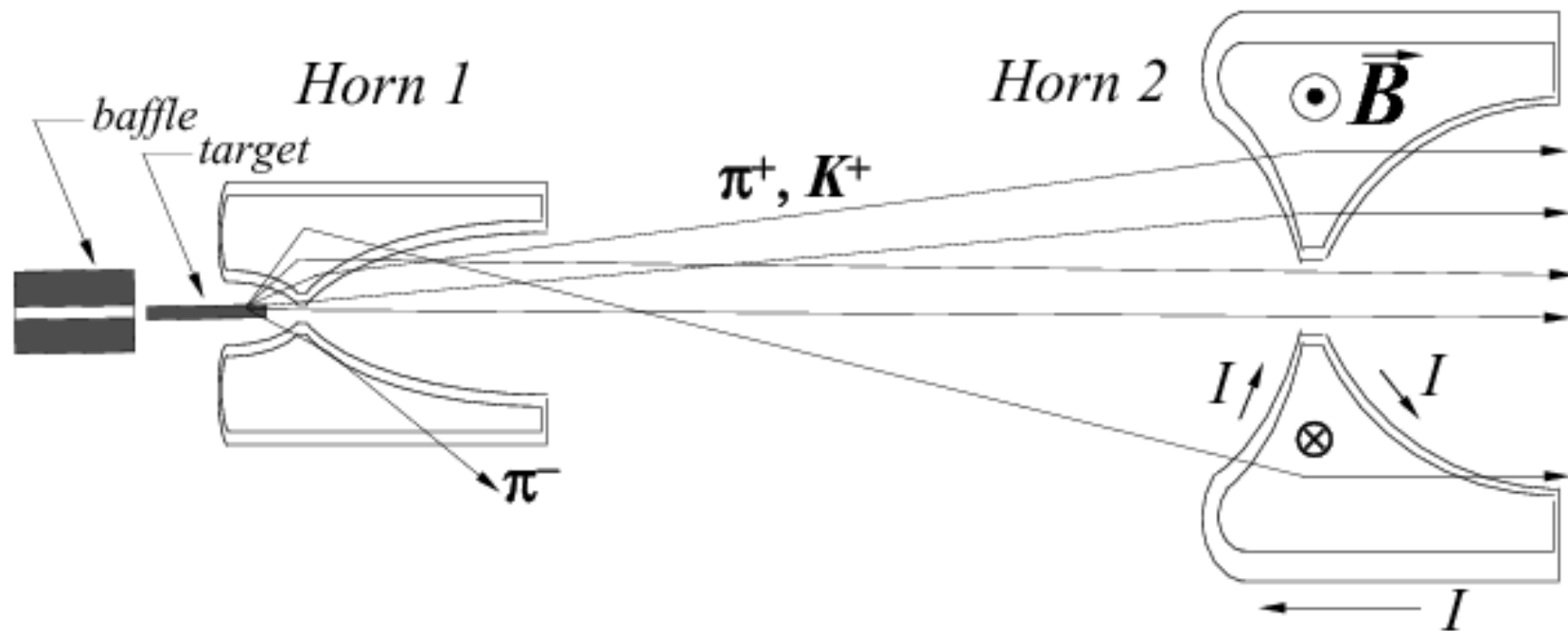

To give a 200 MeV transverse momentum kick to a pion requires a pulsed current of about 180 kA

# Magnetic Horns



# Decay Tunnel

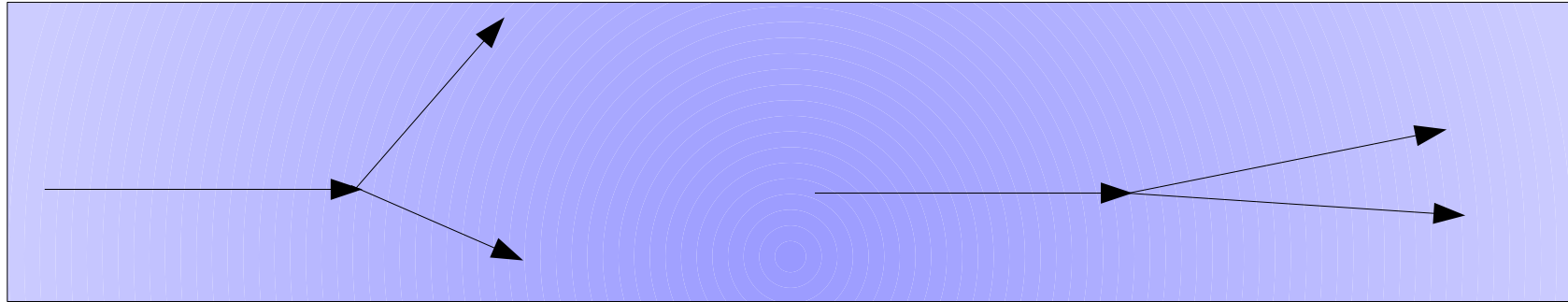

Low Energy decays

High Energy decays

$$P(\pi \rightarrow \nu \mu) = 1 - e^{-t/\gamma \tau} = 1 - e^{-L m_{\pi} / E_{\pi} \tau}$$

Shorter tunnel, less pion decays

Longer tunnel, more pion decays, but muons decay to  $\nu_e$  as well

Vacuum? Then more material is needed to hold it. Air?  
Less material but interactions in decay pipe.

JPARC Facility

50 GeV Ring

$\nu$  line

3 GeV Ring

LINAC

**400 MeV Linac (200 MeV)**  
**1 MW 3 GeV RCS**  
**0.5 MW 30 GeV MR**  
**800 MeV Neutrinos**

# Wide band beams

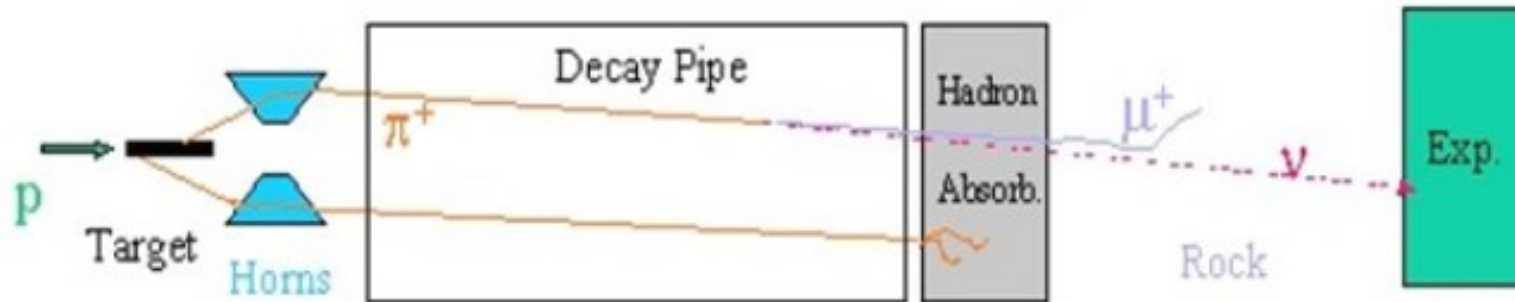

- Large flux of neutrinos.
- Wide range of energies.
- Complex mix of flavours.
- Hard to predict (and measure) neutrino flux.
- Spectrum is a function of radius and decay point

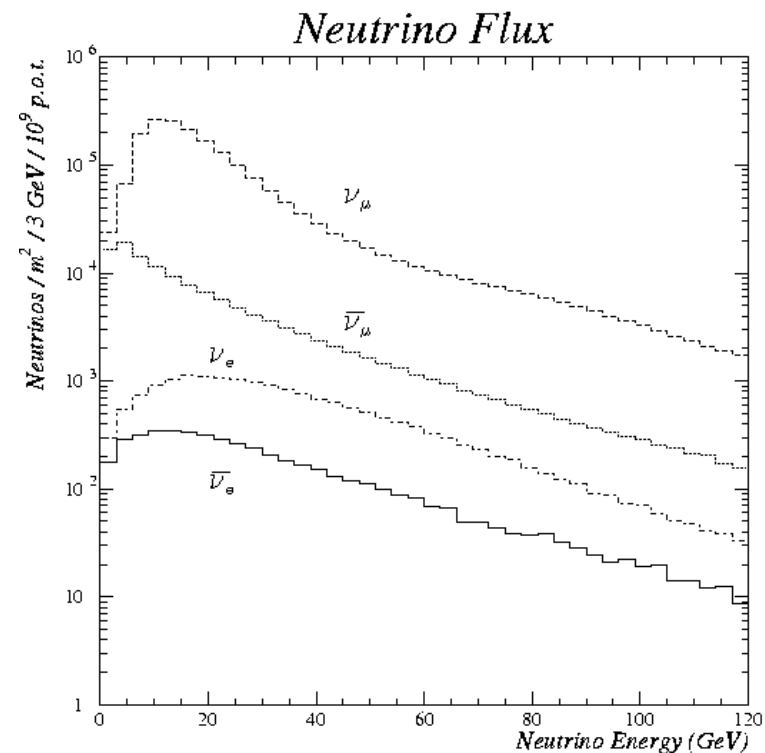

# Narrow Band Beams

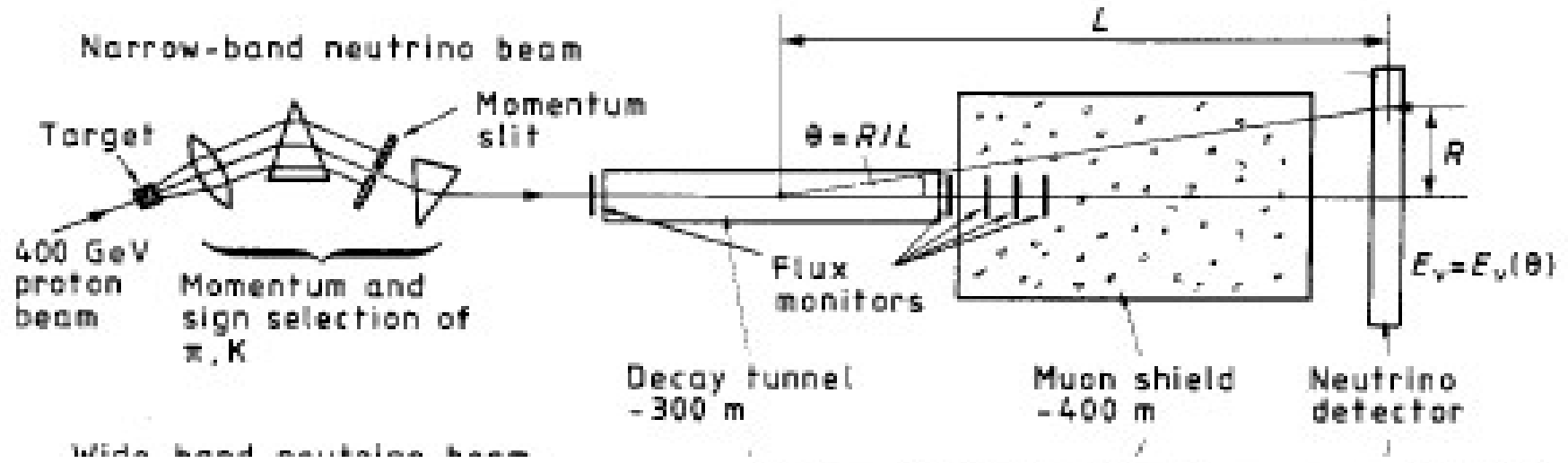

- Flat flux (easy to predict)
- Beam can be tuned to different energies
- flux is 100 times lower than WBB

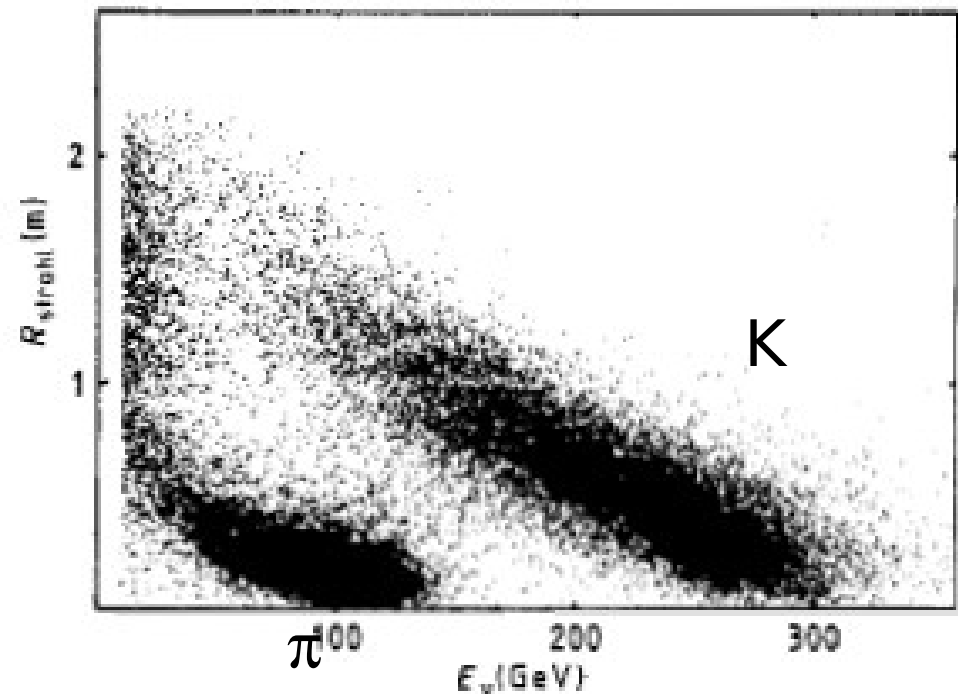

# Off-axis beams

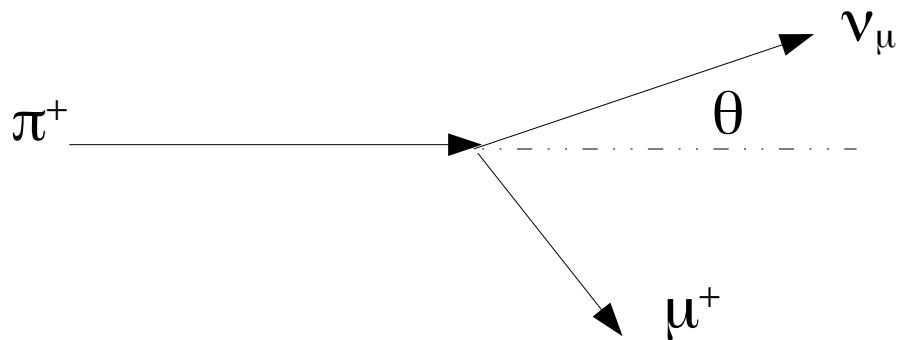

$$E_\nu = \frac{0.43 E_\pi}{1 + \gamma^2 \theta^2} \quad \gamma = \frac{E_\pi}{m_\pi}$$

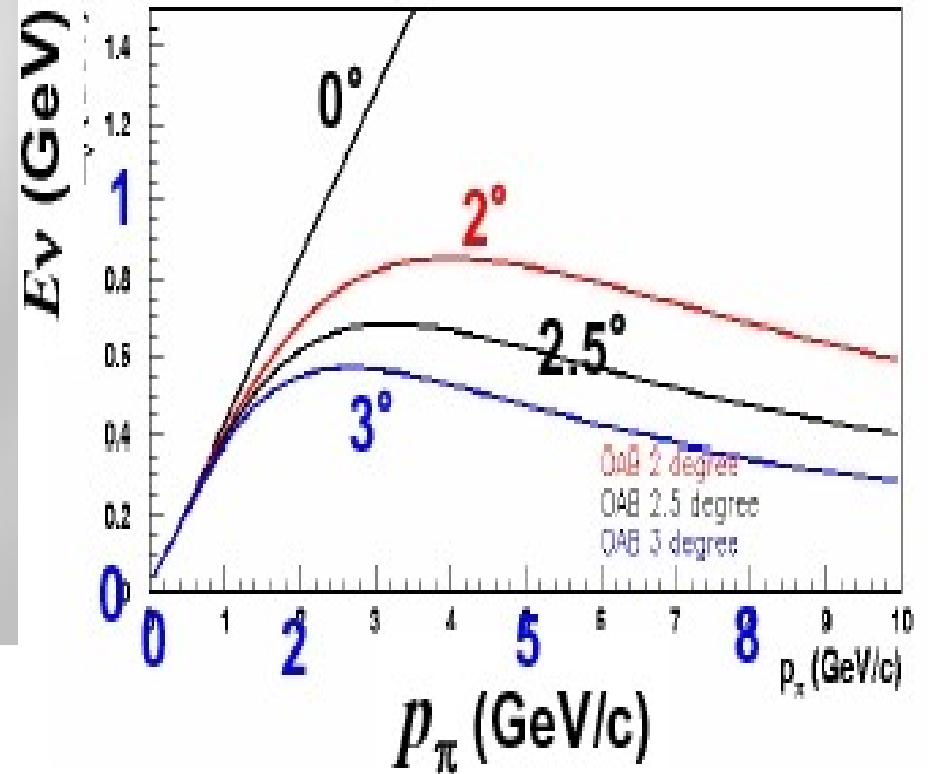
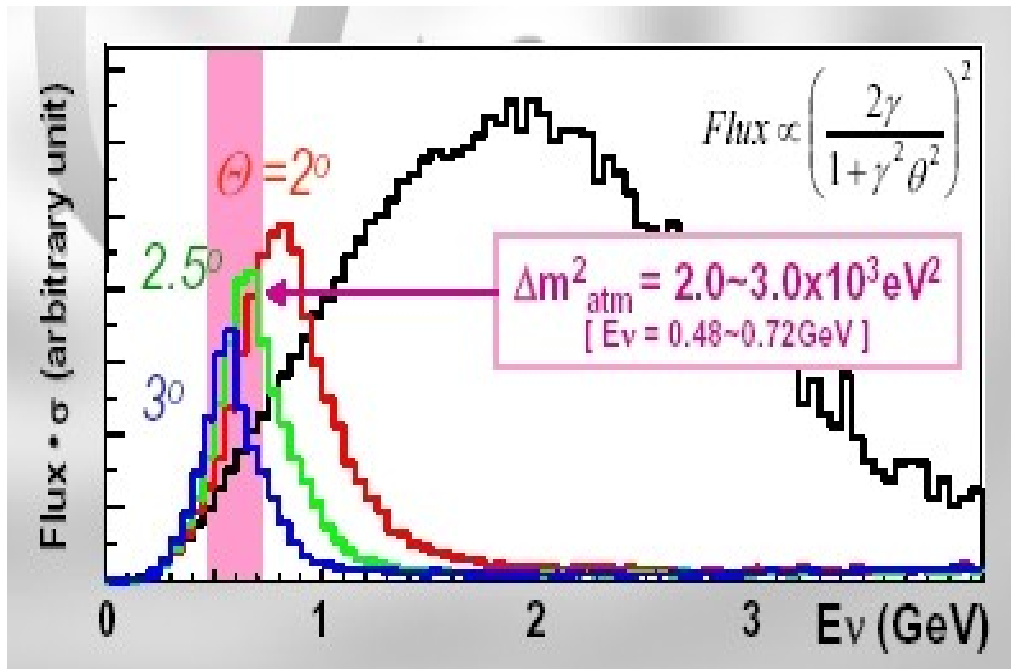

# Neutrino Detection

So, you want to build  
a neutrino detector?

# So, you want to build a neutrino detector?

Ha ha. Good one. 🤔

# So, you want to build a neutrino detector?

~~Ha ha. Good one.~~ 😂

Oh you were being serious!? 😬

Alrighty then, riddle me this...

# So, you want to build a neutrino detector?

- How many events do you need to do the physics?
  - Determines detector mass
  - Determines the target type

# So, you want to build a neutrino detector?

- How many events do you need to do the physics?
  - Determines detector mass
  - Determines the target type
- What kind of interaction?  $\nu_e$ ,  $\nu_\mu$ , CC, NC?

# So, you want to build a neutrino detector?

- How many events do you need to do the physics?
  - Determines detector mass
  - Determines the target type
- What kind of interaction?  $\nu_e$ ,  $\nu_\mu$ , CC, NC?
- What do you want to measure?
  - Energy? Final state particles? This influences detector technology

# So, you want to build a neutrino detector?

- How many events do you need to do the physics?
  - Determines detector mass
  - Determines the target type
- What kind of interaction?  $\nu_e$ ,  $\nu_\mu$ , CC, NC?
- What do you want to measure?
  - Energy? Final state particles? This influences detector technology
- What sort of backgrounds do have to deal with?
  - More influence on technology – usually conflicting with signal requirements.

# So, you want to build a neutrino detector?

- How many events do you need to do the physics?
  - Determines detector mass
  - Determines the target type
- What kind of interaction?  $\nu_e$ ,  $\nu_\mu$ , CC, NC?
- What do you want to measure?
  - Energy? Final state particles? This influences detector technology
- What sort of backgrounds do have to deal with?
  - More influence on technology – usually conflicting with signal requirements.
- How much  do you have?

# Usual collider detector

## The ATLAS Detector

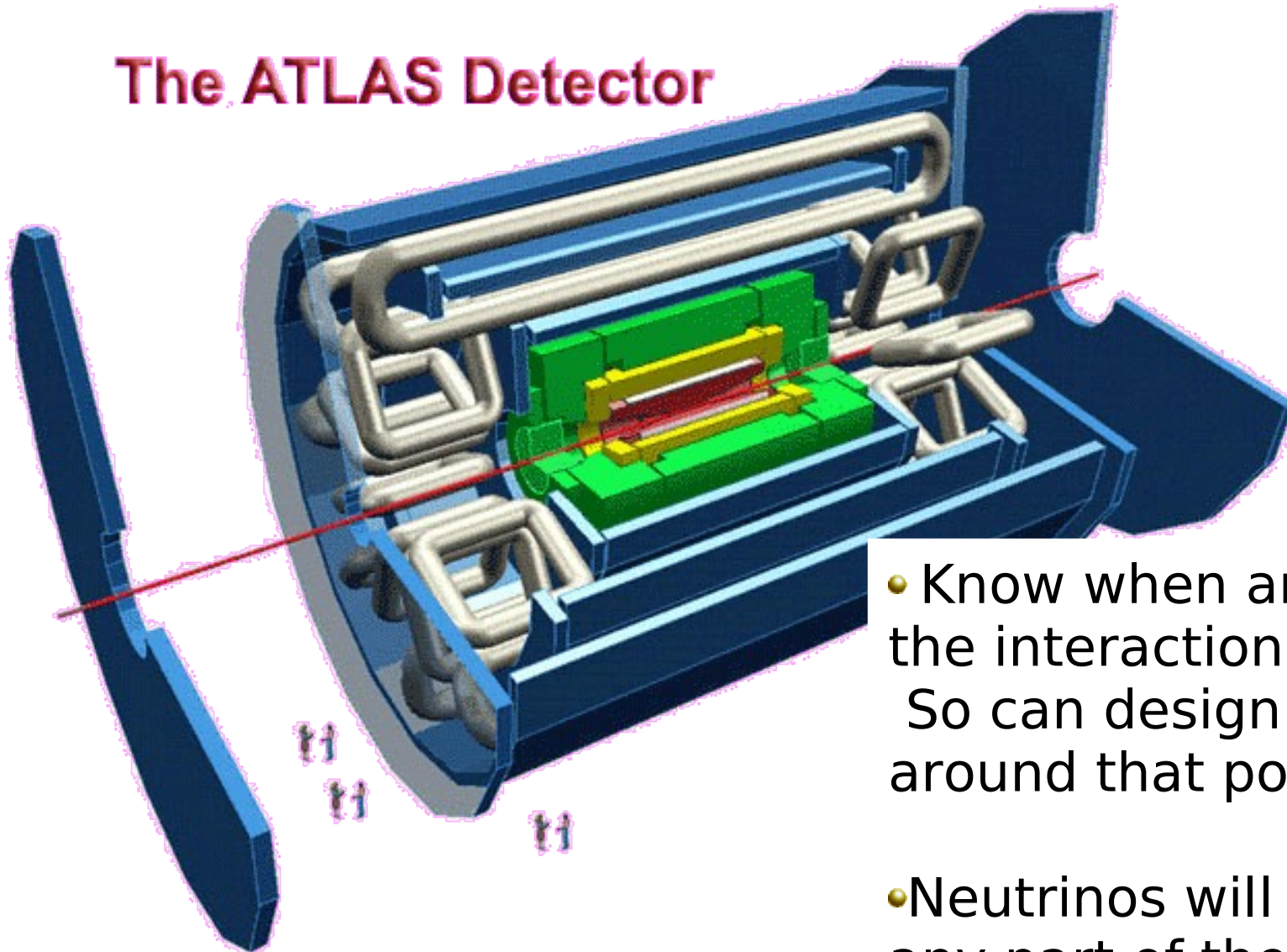

- Know when and where the interaction will occur. So can design a detector around that point
- Neutrinos will interact in any part of the detector

# Neutrino Detectors

- No neutrino colliders – detector IS the target
- Low cross section implies large mass and hence **cheap** material
- Neutrinos interact everywhere – vertex can be anywhere
- Neutrinos interact in matter - so final state is subject to nuclear potentials
- Need to identify charged lepton to separate NC and CC and neutrino flavour
- Measurement of energy and scattering angle of charged lepton
- Measurement of total hadronic energy
- Identification of single hadrons for hadronic studies

No experiment can satisfy all these requirements  
Most experiments fall into one of a few types

# Types of detectors

- Radiochemical experiments
- Water ( $\text{H}_2\text{O}$  or  $\text{D}_2\text{O}$ ) experiments
- Scintillator detectors
- Tracking calorimeters

# Radiochemical Experiments

This technique uses the production of radioactive isotopes.

Davis-Pontecorvo experiment was the first attempt to use this to look at solar neutrinos



The isotopes Ar or Ge are radioactive. In this type of experiment the isotopes are chemically extracted and counted using their decay

Disadvantage is that there is no information on interaction time or neutrino direction, and only really generates “large” count rates for low energy neutrinos (in the MeV range)

# The Davis Experiment

The very first solar neutrino experiment in the Homestake mine in South Dakota

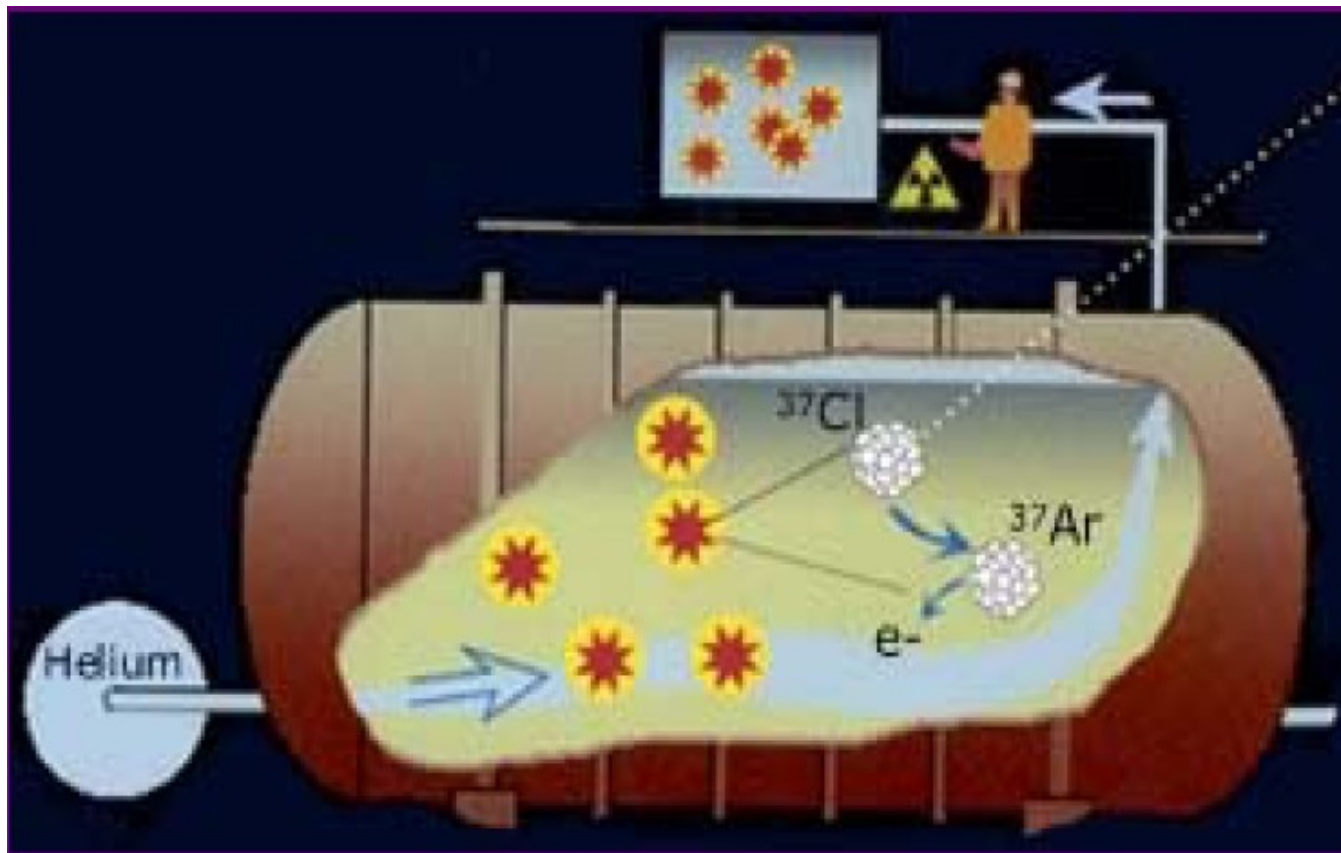

615 tonnes of  $\text{Ccl}_4$   
Ran from 1968  
to 1994

Individual argon  
atoms are captured  
and counted.

1 atom per 2 days.

Threshold : 814 keV

# Water Experiments

Water is a very cheap target material – these experiments detect charged particles using Cerenkov radiation.

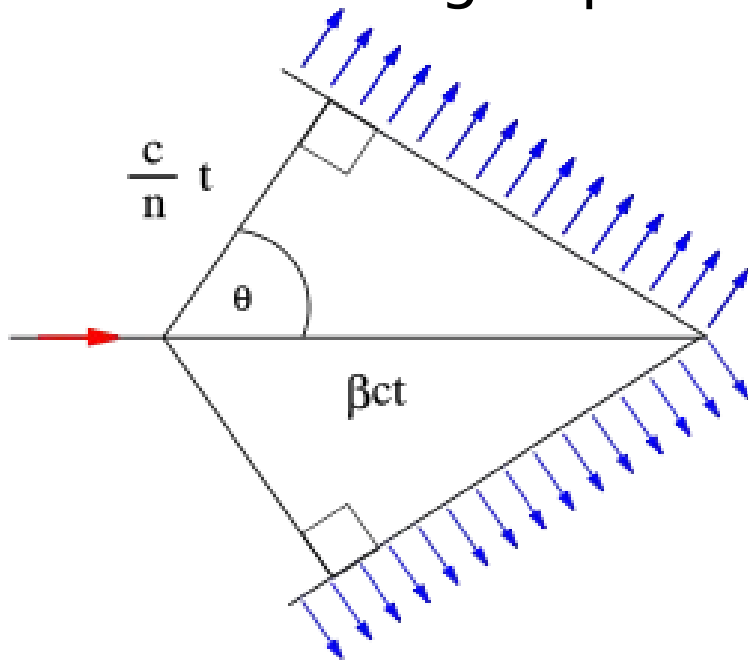

If a charged particle moves through a material with  $\beta > 1/n$  it produces an EM shockwave at a particular angle.

$$\cos \theta = 1 / \beta n$$

The shockwave can be detected and used to measure the particle direction and vertex.

Particles below threshold and neutral particles are not detected

\*See Antonis' lecture on Friday for more uses of the Cerenkov technique

# Principle of operation

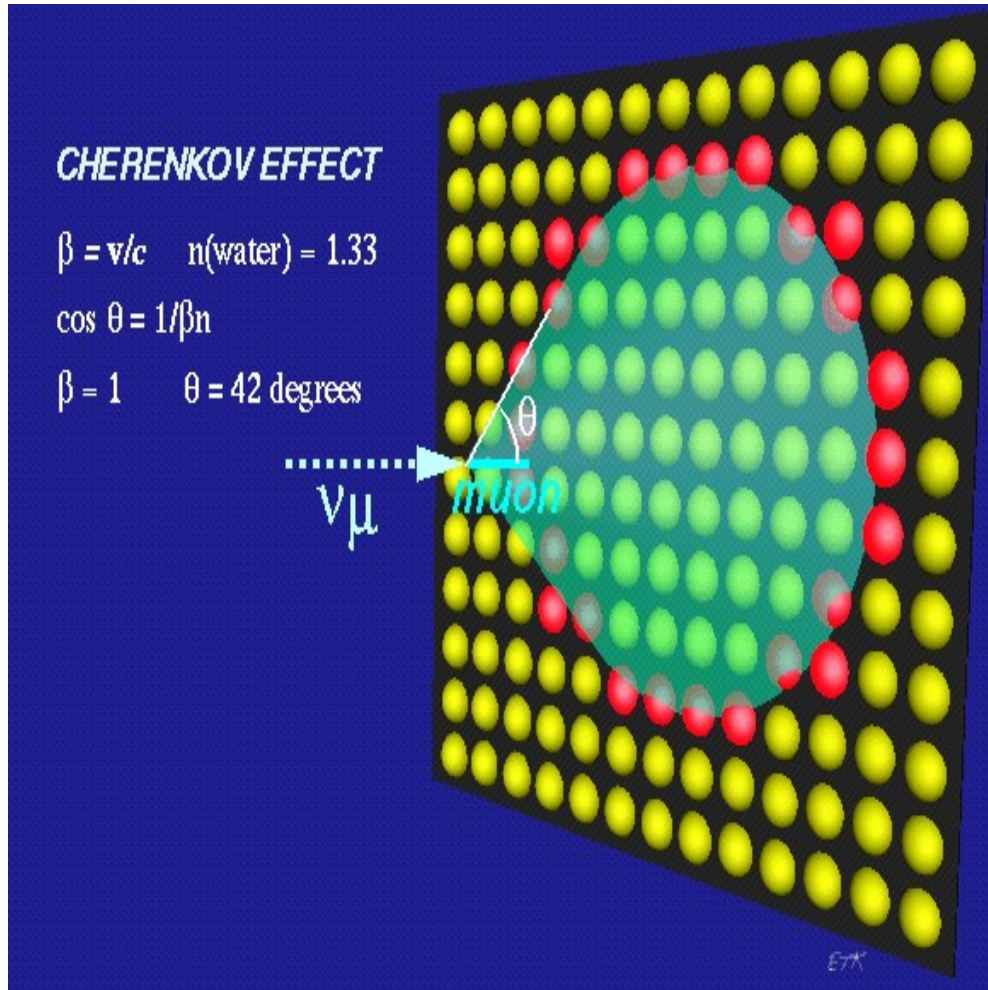

- Cerenkov light detected as a ring or circle by PMTs
- Vertex from timing
- Direction from cone
- Energy from summed light
- No neutrals or charged particles under Cerenkov threshold
- Low multiplicity events

# Super-Kamiokande

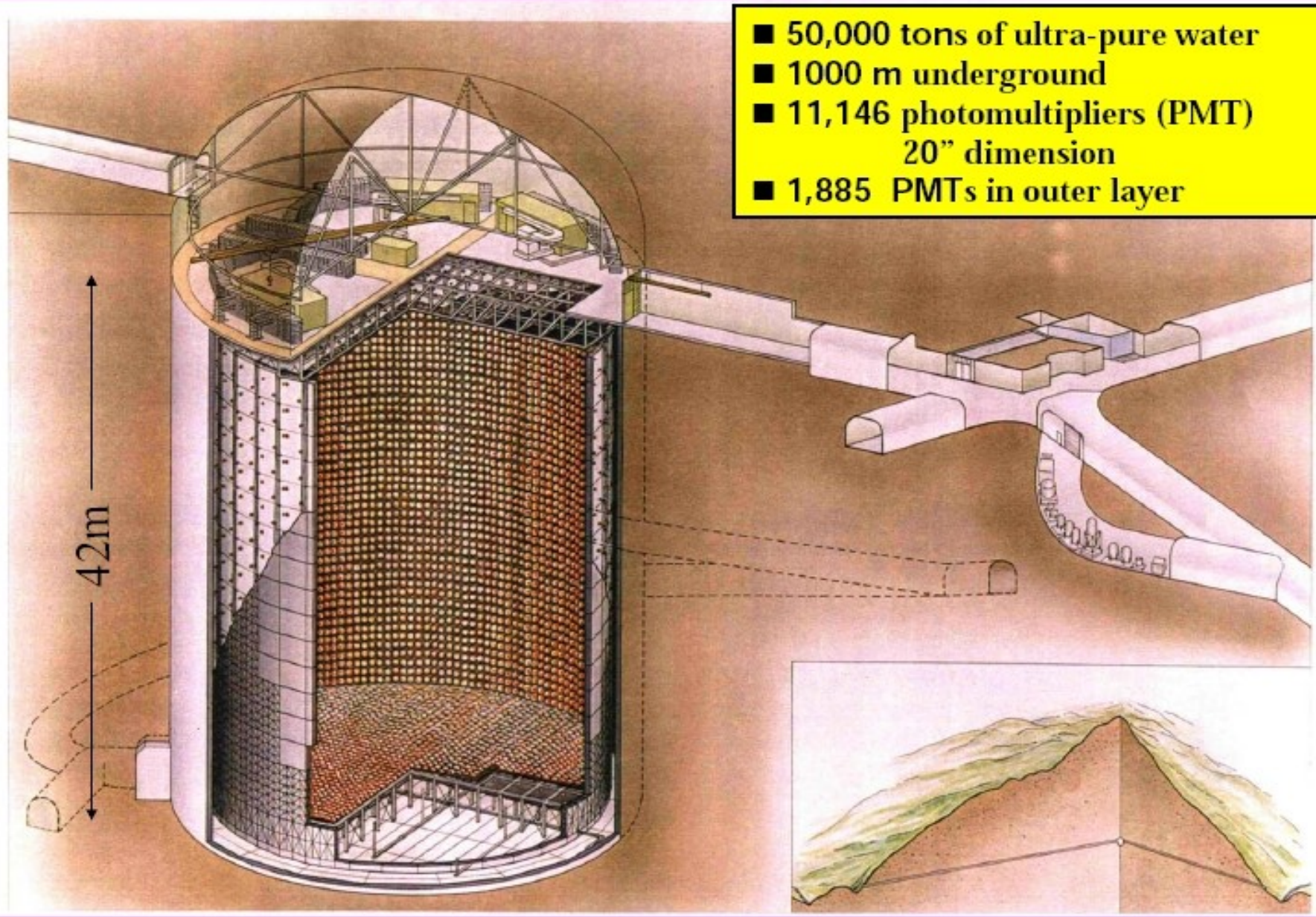

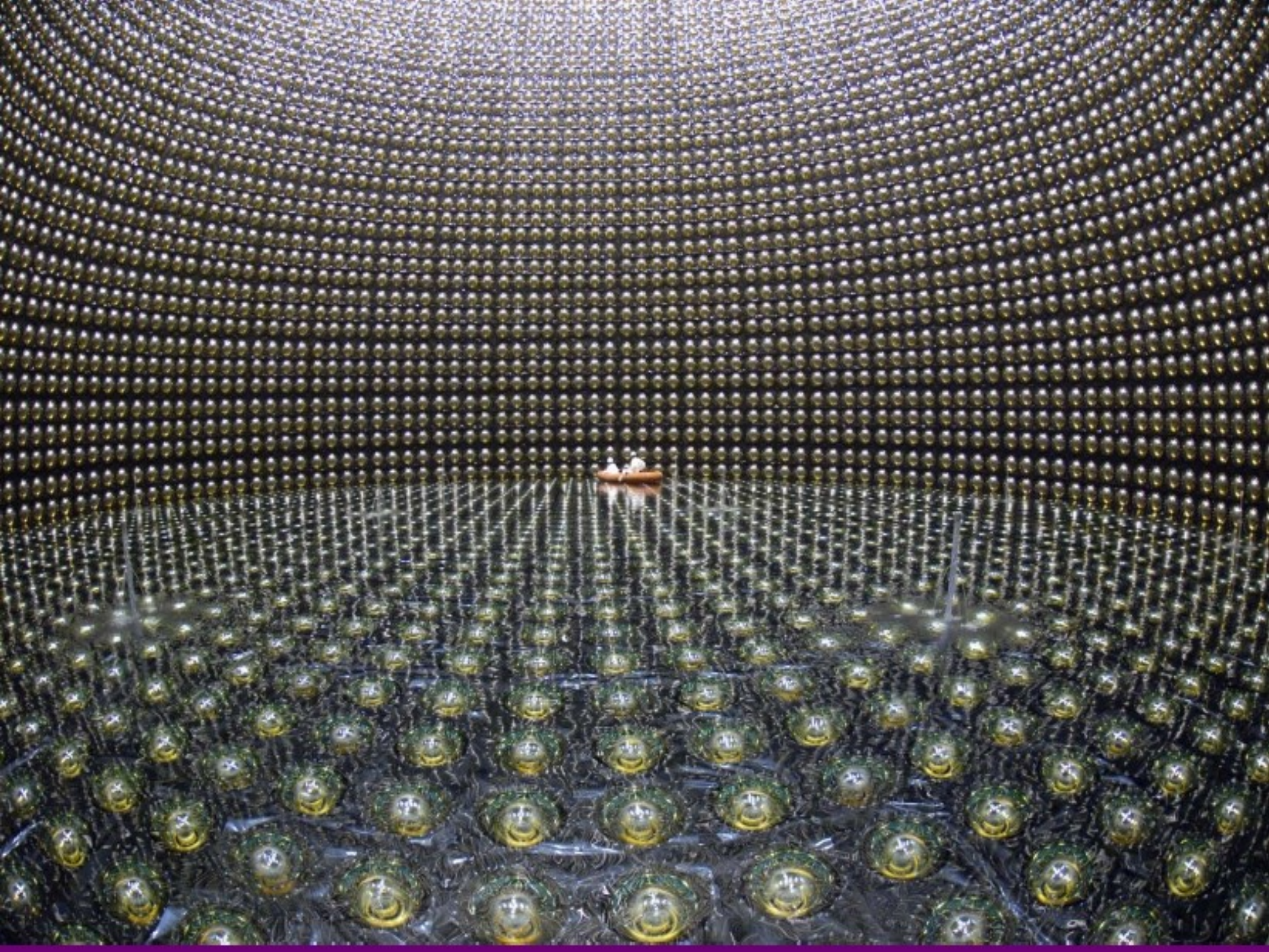

# Directionality

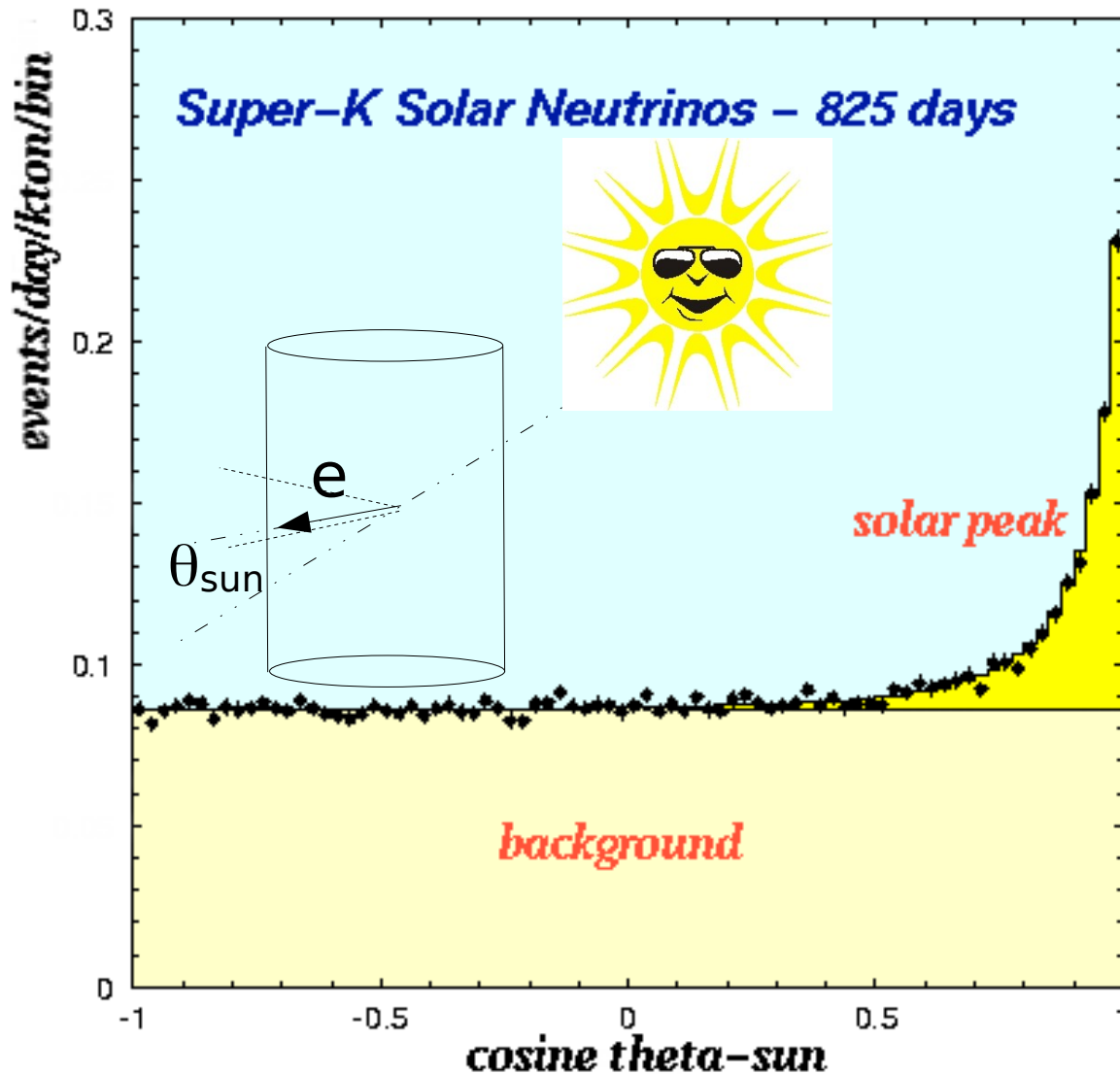

For simple events, the direction of the ring can be used to point back to the neutrino source

Proof that these neutrinos were coming from the sun

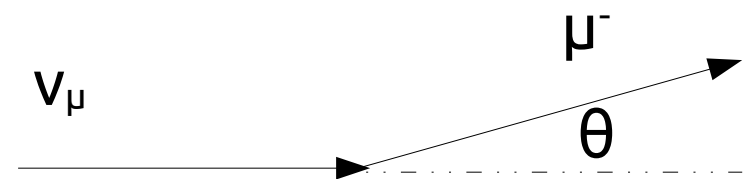

e-like

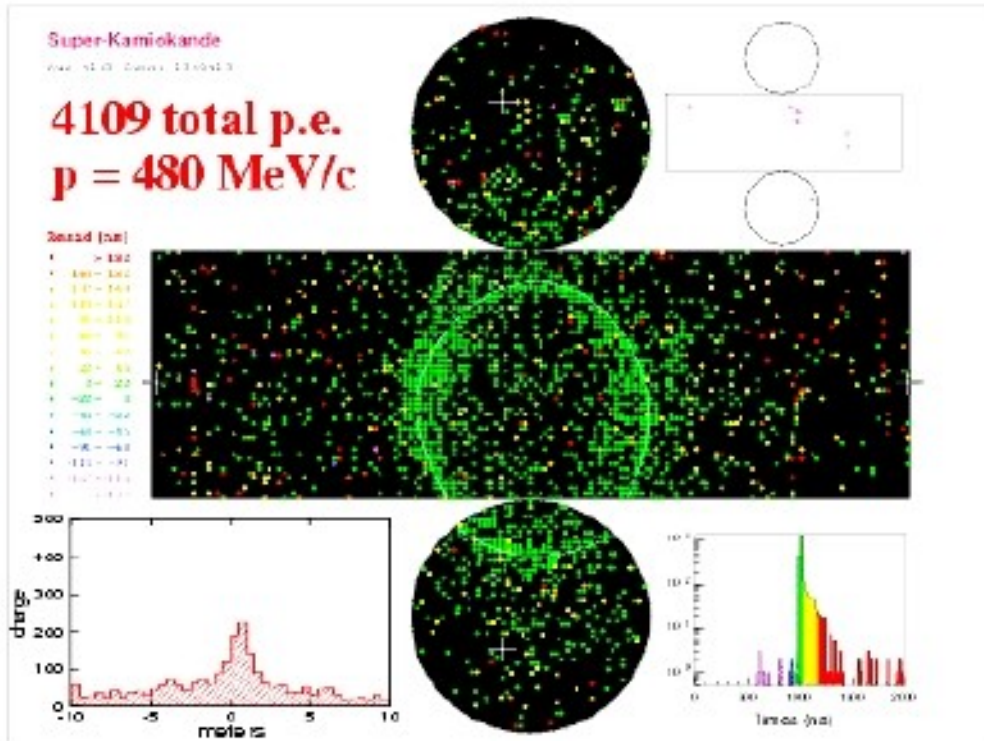

$\mu$ -like

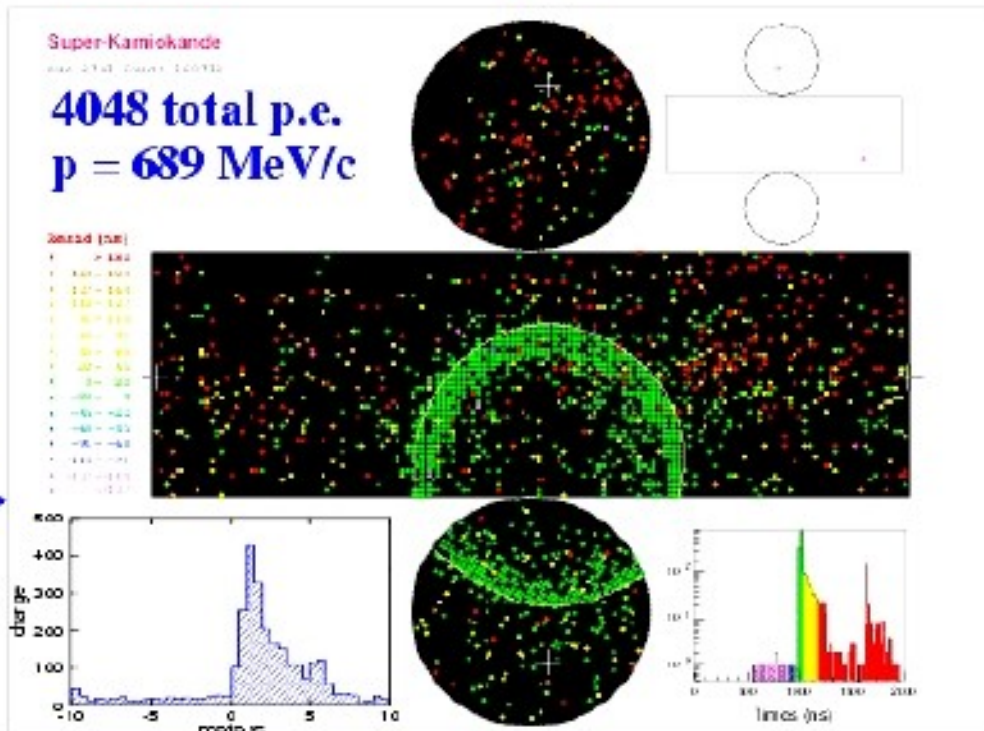

Electron-like : has a fuzzy ring

Colours = time of hit  
Event energy = sum of PMT signals

Muon-like : has a sharp edged ring and particle stopped in detector.

# Problems

- Any particle below threshold is not seen
- Neutral particles are not observed
- Multi-ring events are extremely hard to reconstruct

## Super-Kamiokande IV

Run 999999 Sub 2 Event 7  
16-04-13:05:43:18  
Inner: 8104 hits, 30188 pe  
Outer: 3 hits, 2 pe  
Trigger: 0x07  
D\_wall: 1130.7 cm  
Evis: 3.3 GeV

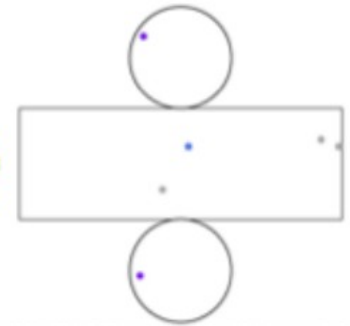
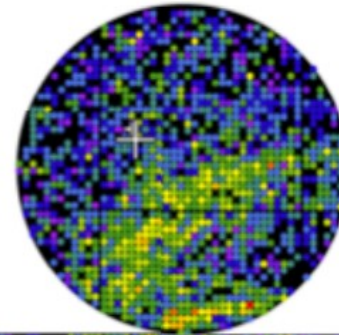

## Charge (pe)

- >26.7
- 23.3-26.7
- 20.2-23.3
- 17.3-20.2
- 14.7-17.3
- 12.2-14.7
- 10.0-12.2
- 8.0-10.0
- 6.2- 8.0
- 4.7- 6.2
- 3.3- 4.7
- 2.2- 3.3
- 1.3- 2.2
- 0.7- 1.3
- 0.2- 0.7
- < 0.2

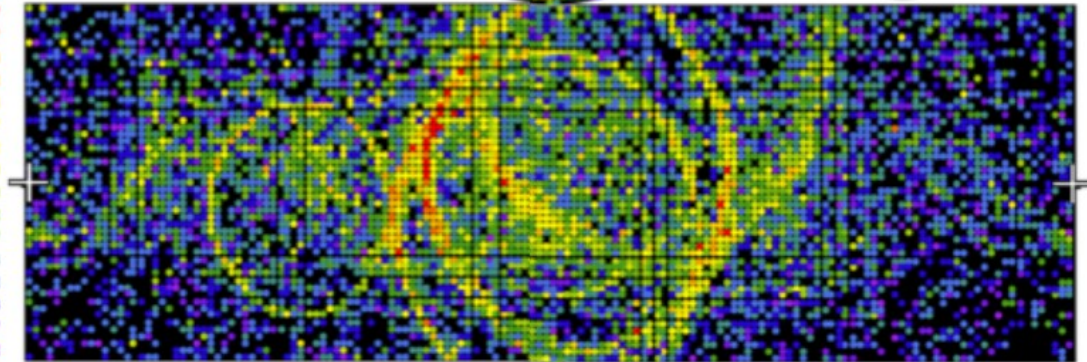

CC  $\nu_\tau$

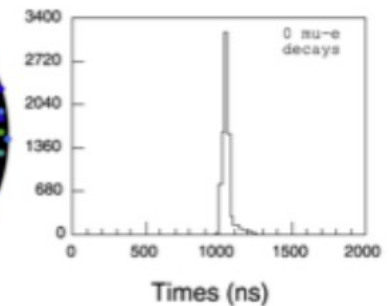
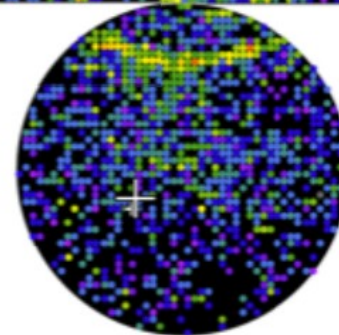

# Scintillator Detectors

Light emission following ionisation

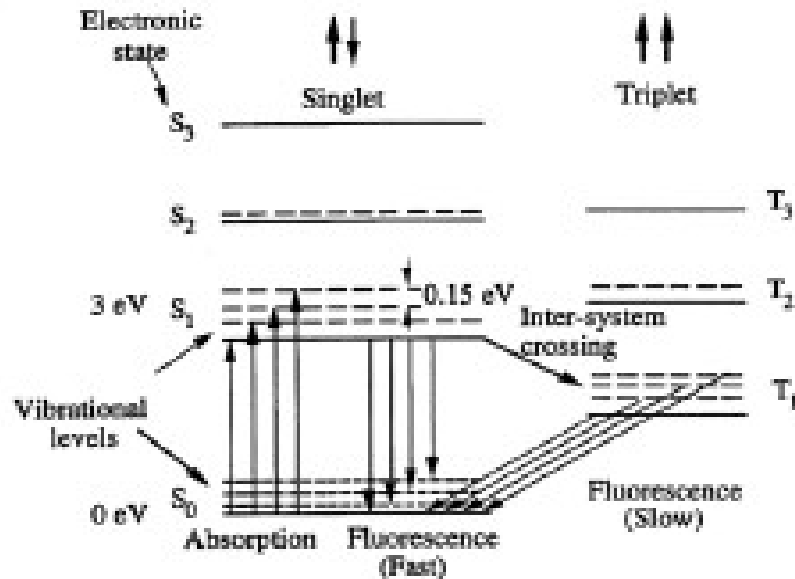

Organic liquids and plastics

Inorganic crystals

Nobel liquids

- In a good scintillator, much **more** light is emitted by scintillation than by the Cerenkov process.
- **Scintillation light is isotropic and there is no threshold.**
- But no information on directionality, the emission wavelength depends on the scintillator material, and the scintillator is usually highly toxic.

# JUNO

WARWICK

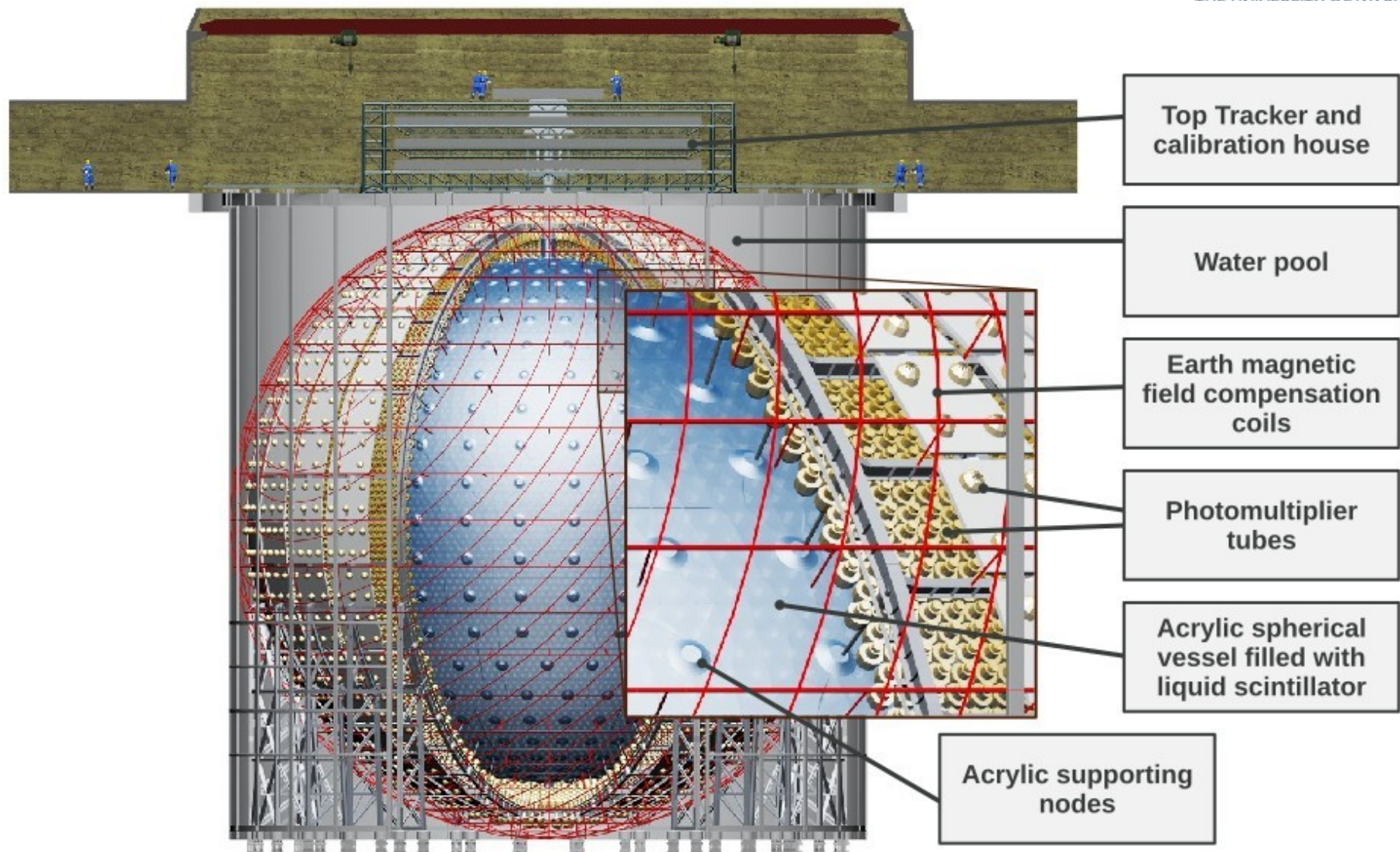

Radioactive background is a major problem – everything this is built from has to be from low-radioactivity materials.

# Tracking Calorimeters

Layers of target: eg. steel, marble, glass

Layers of ionization detector:  
spark chambers  
proportional counters  
scintillator strips  
drift tubes  
resistive plate chambers (RPCs)

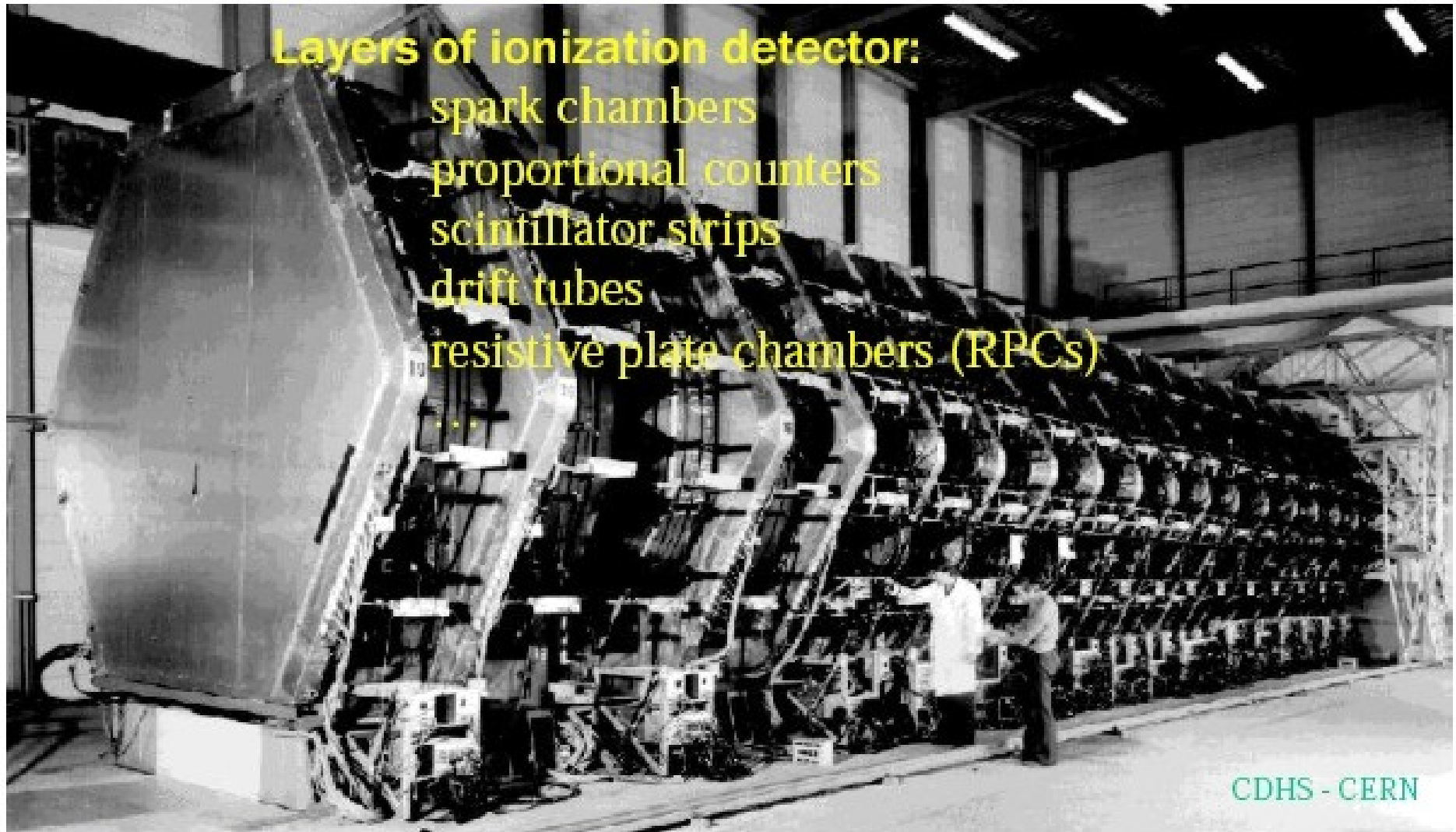

# T2K ND280

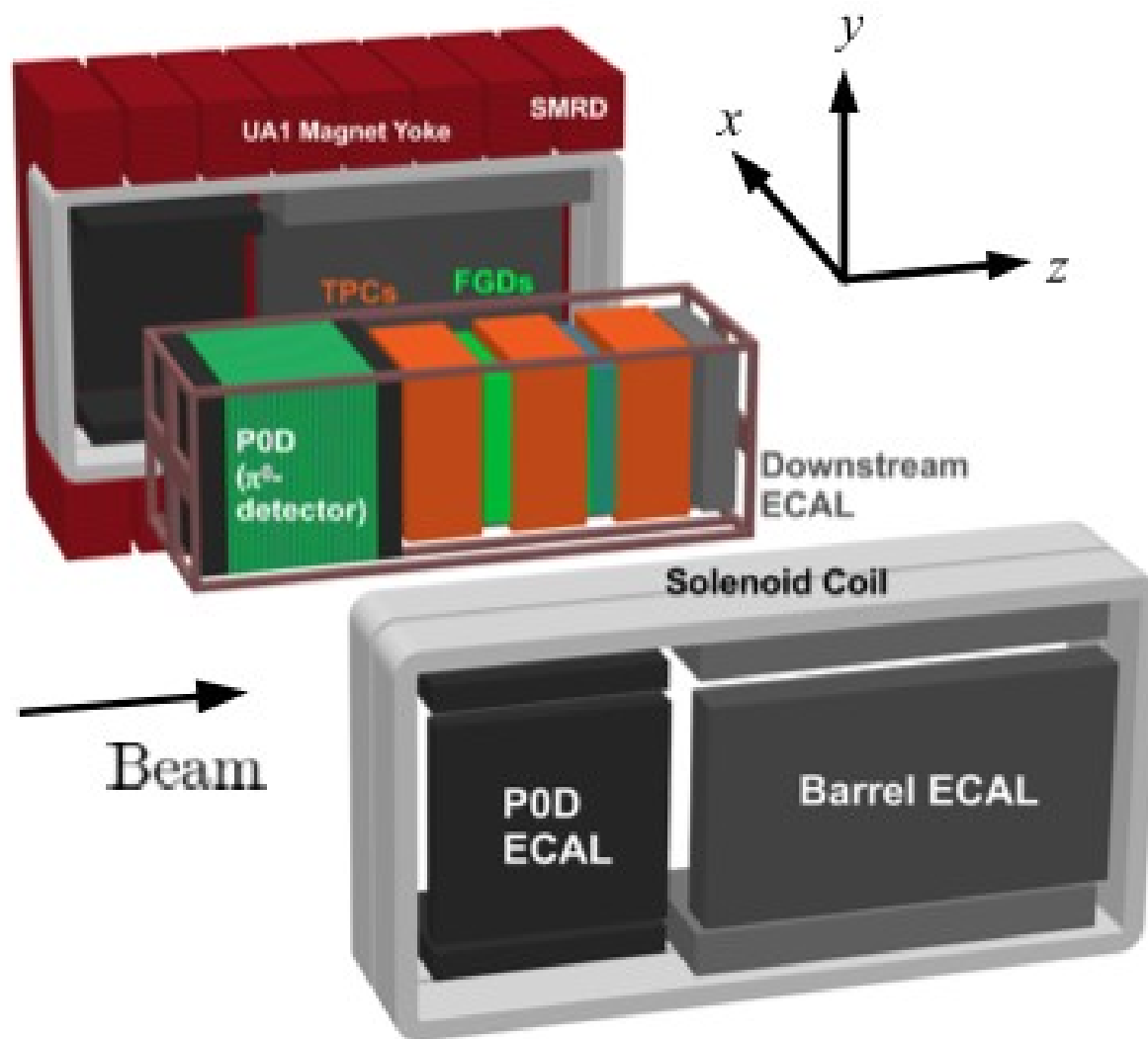

# T2K

Event number : 53975 | Partition : 63 | Run number : 5012 | Spill : 52286 | SubRun number : 10 | Time : Mon 2010-06-14 02:41:00 JST | Trigger: Beam Spill

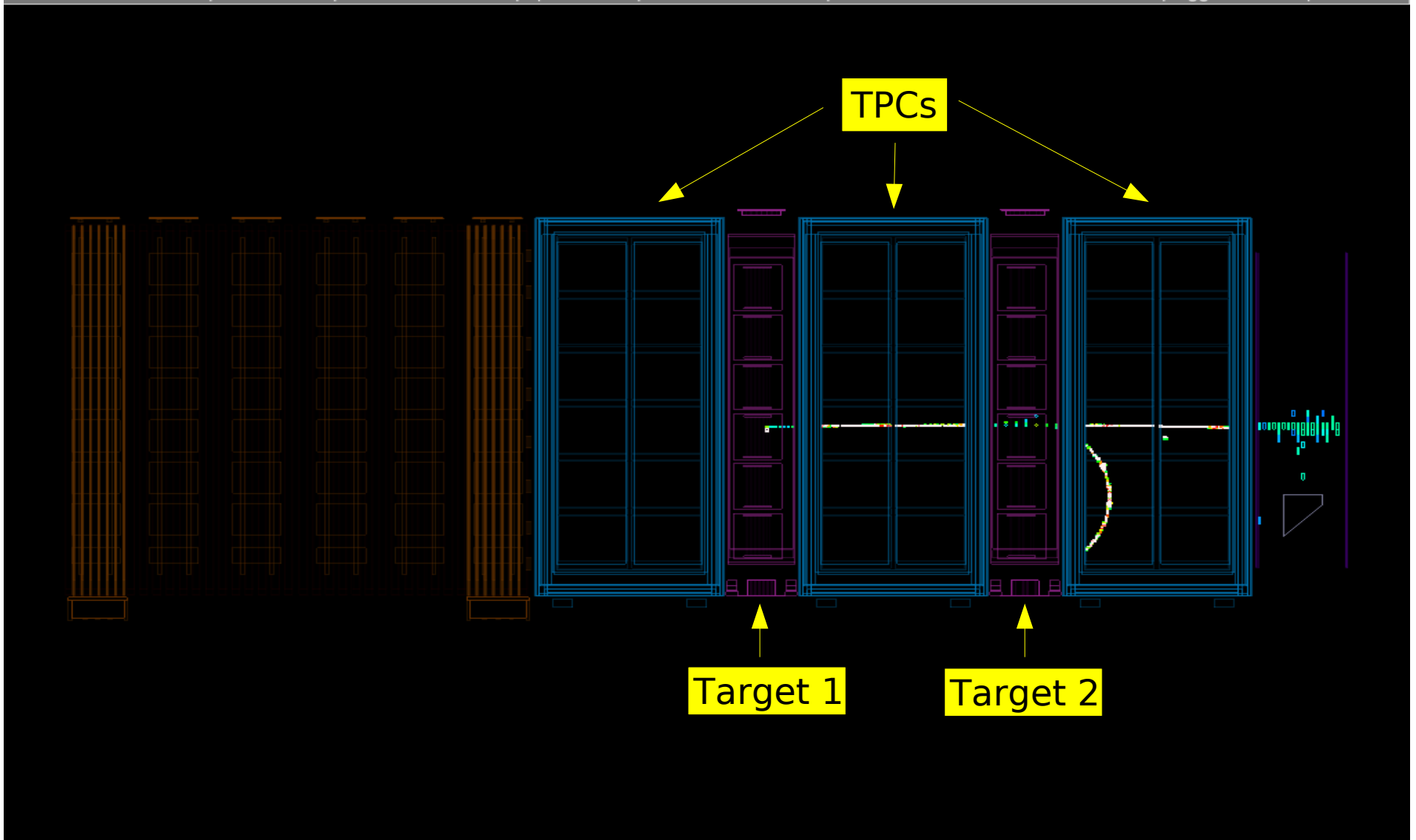

# Liquid Argon TPCs

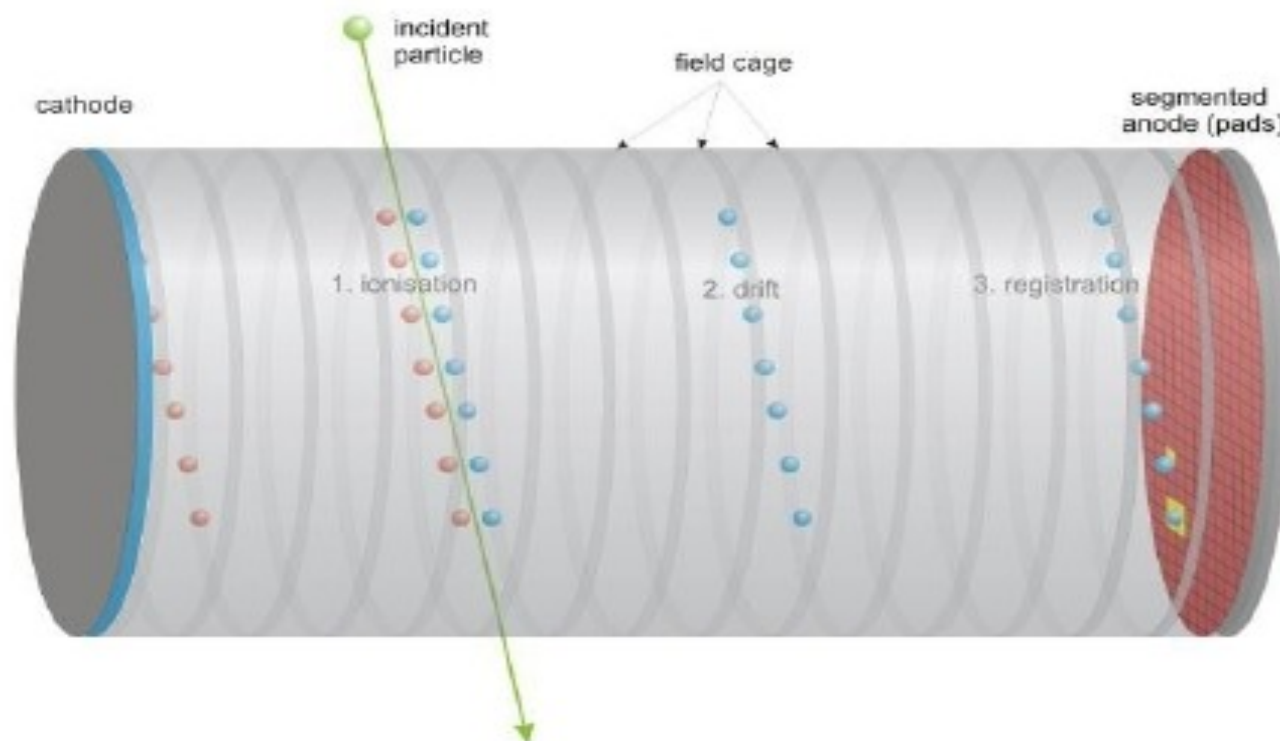

3D tracking with excellent resolution  
Calorimetry from energy deposition in filler material  
Filler can be gas or liquid.  
Neutrino Physics looking at liquid argon TPCs

# LAr event



RUN 14729, EVENT 41  
PLANE 2  
July 11, 2024

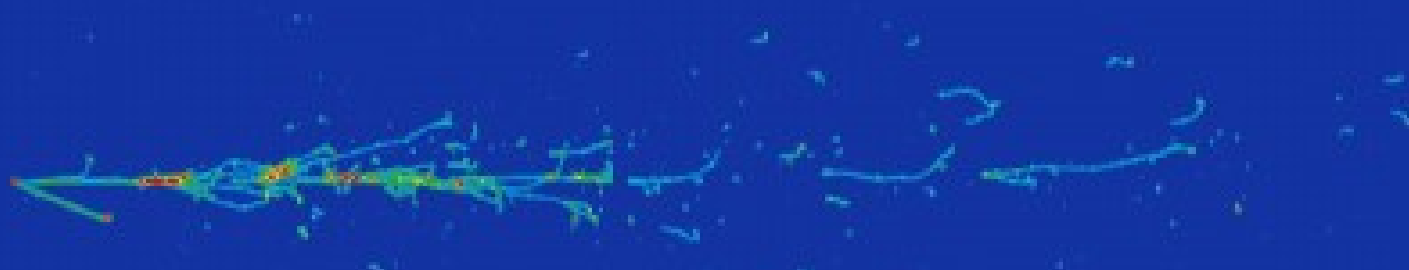

$\nu_e$  candidate

30 cm



# Summary

- Type of neutrino detectors depend on target, event rate, and interaction type and cost
- 4 “main” techniques
  - radiochemical (low threshold but no direction or timing information - sub-MeV neutrinos)
  - water cerenkov (high threshold, cheap target mass, direction and timing but only low multiplicity events - 100 MeV up to a few GeV)
  - scintillator (no threshold but no directionality unless enhanced by water cerenkov - few MeV)
  - tracking calorimeters (high energy events - full reconstruction of events - 1 GeV and up)

# Tracking Chambers

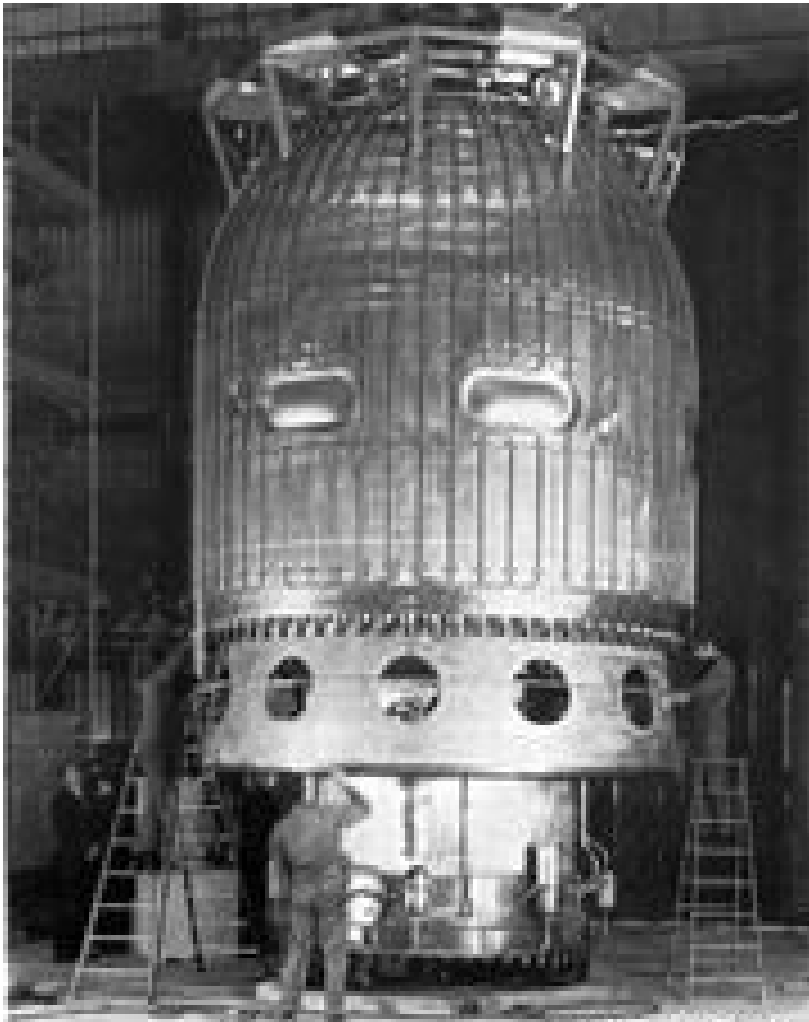
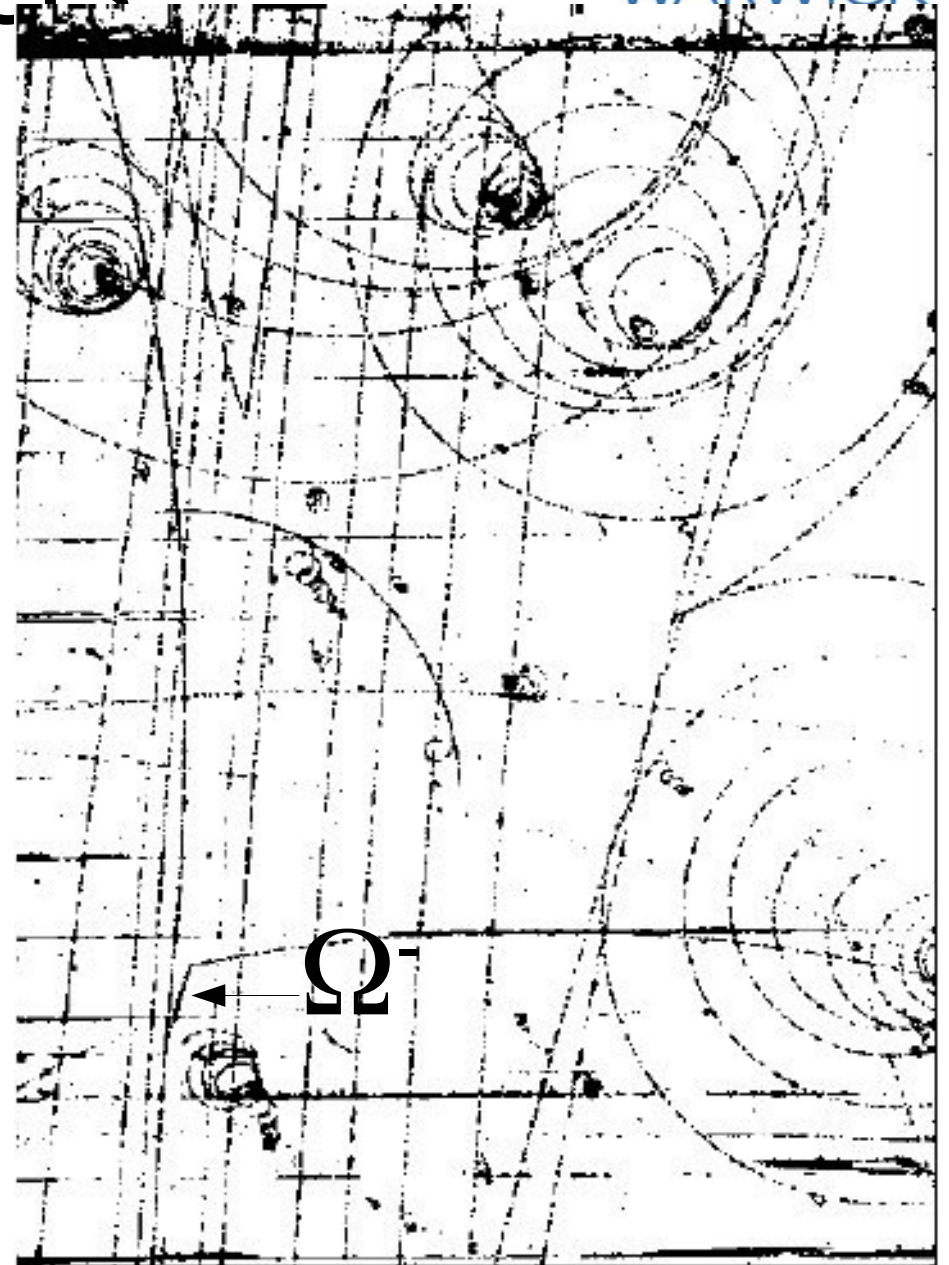

Photo: CERN

BEBC Chamber





The LBL Frankenstein

S-UTS in Japan (Nagoya)

OPERA Experiment



Dedicated hardware  
Hard coded algorithms

**High speed CCD Camera (3 kHz)**  
**Synchronization of objective lens and stage**  
**1h35m/brick for 100 predictions**

# Liquid Argon TPCs

Huge liquid argon TPC. Bubble chamber like imagery and fully active calorimetry

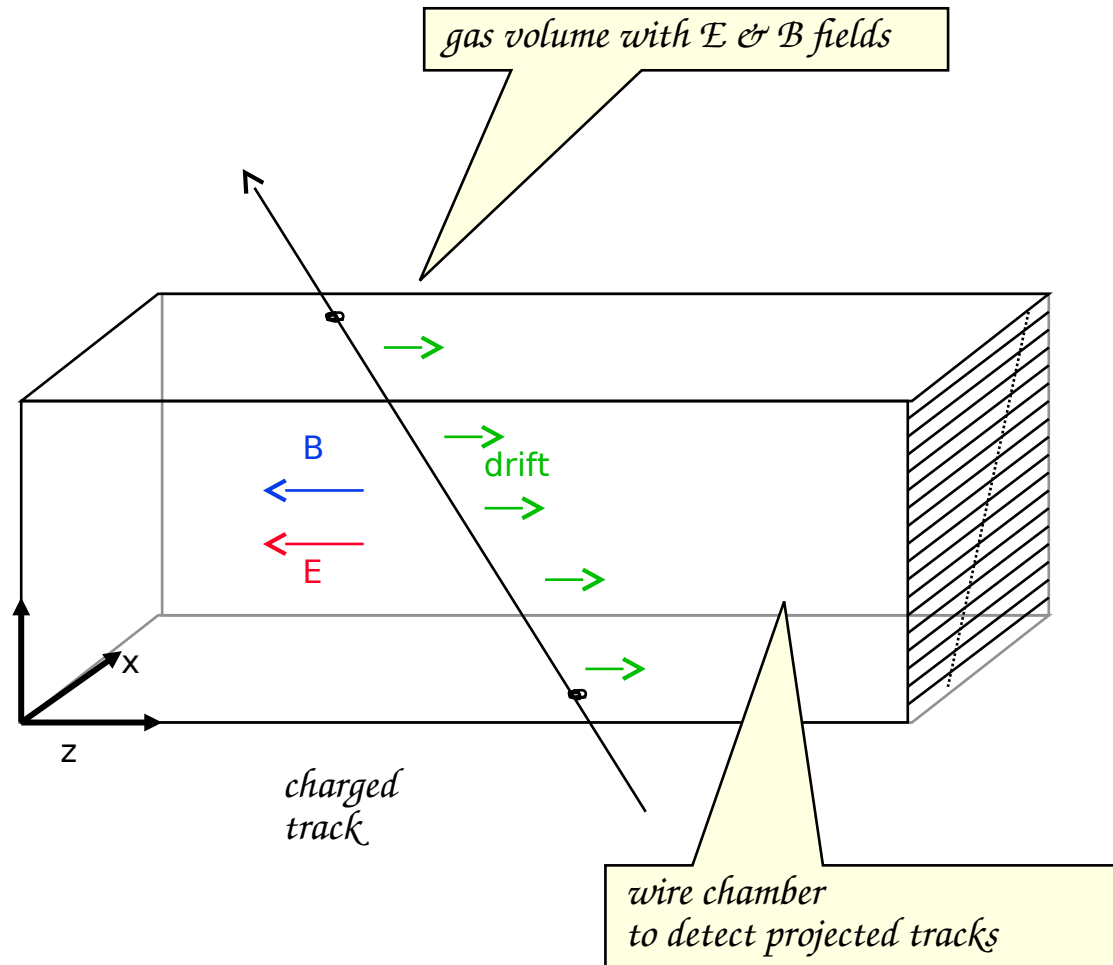

Run 308 Event 332 Collection view

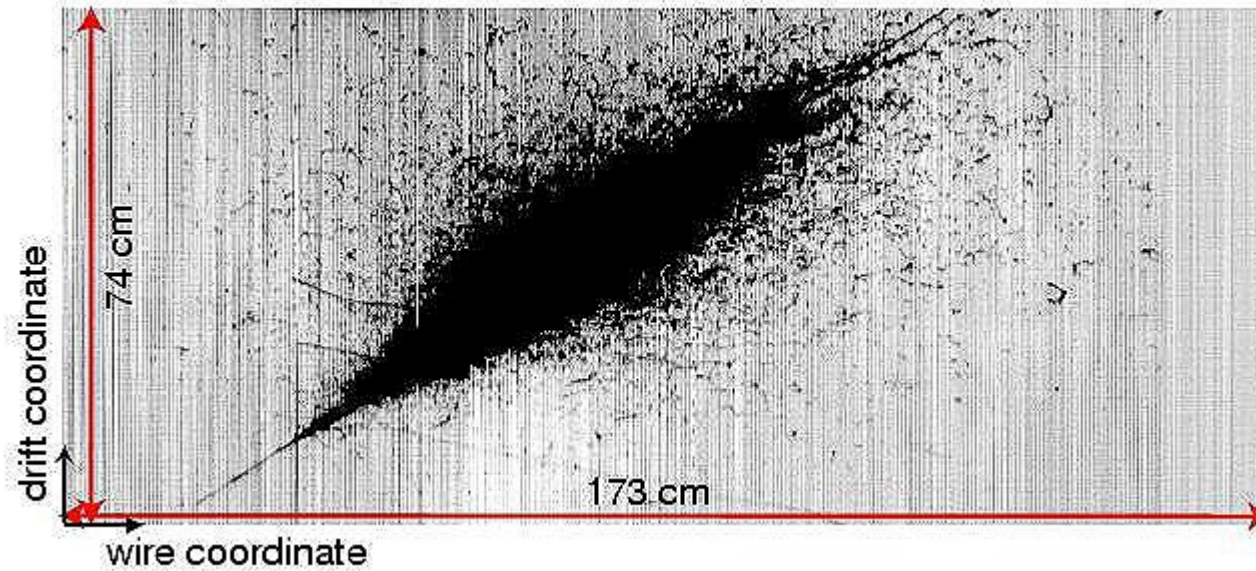

# EM Shower

Run 308 Event 7 Collection view

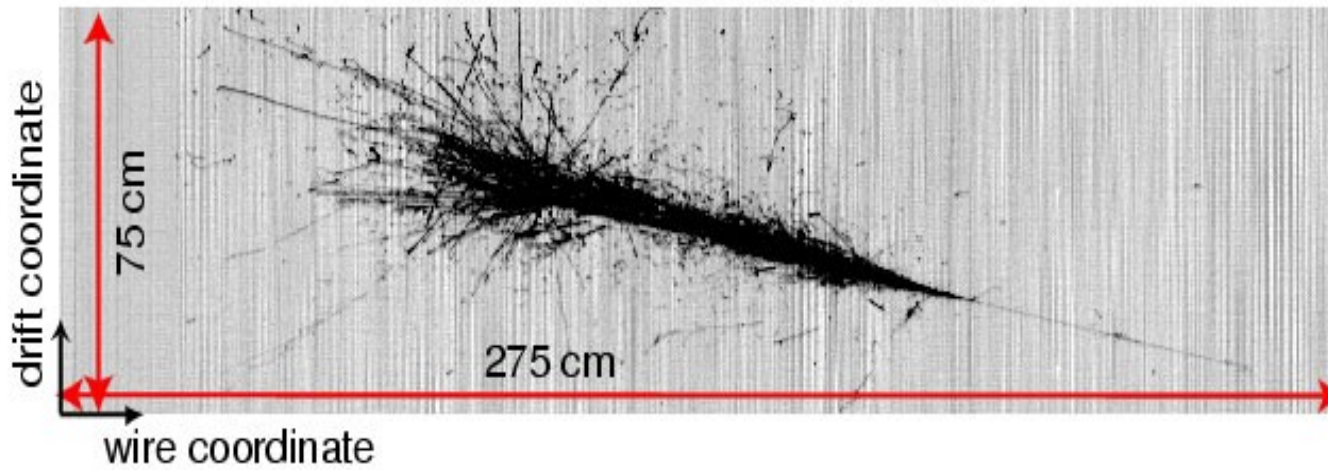

# Hadronic Shower

# Neutrino Detectors

- No neutrino colliders – detector IS the target
- Low cross section implies large mass
- Neutrinos interact everywhere – vertex can be anywhere
- Identification of charge lepton to separate NC and CC
- Measurement of energy and scattering angle of charged lepton
- Measurement of total hadronic energy
- Identification of single hadrons for hadronic studies
- Use of different target materials (nuclear effects)

No experiment can satisfy all these requirements  
Most experiments fall into one of a few types

# NUTEV

Iron Sampling calorimeter : CDHS,CHARM,CCFR,NUTEV,MINOS

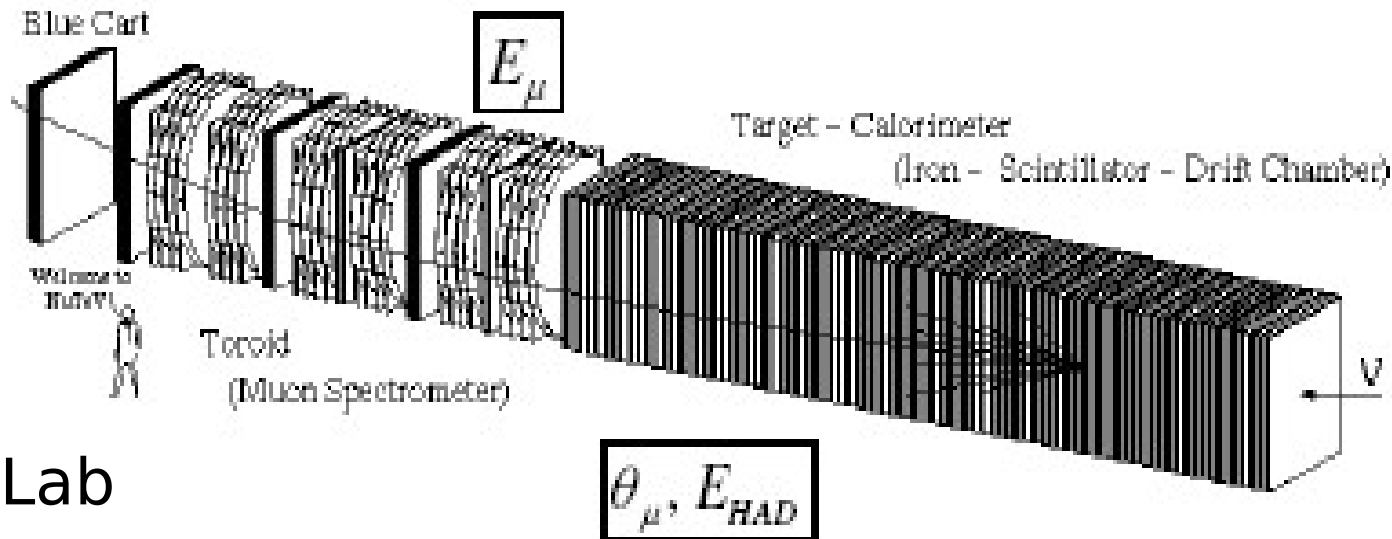

FermiLab

- Typically used for high energy ( $>$  a few GeV) beams
- Iron plates (target) interspersed by scintillator planes
- Muon tracked and radius of curvature measured in toroid
- Hadronic energy summed from active detector but single track resolution is not achievable

# NuTeV Event Display

Run: 5467 Event: 773 Igate: 1 Date: Fri Sep 6 23:45:58 1996

Triggers: **1** **2** **3** **4** 5 6 7 **8** 9 10 11 12 13

EMU1:	31.70 GeV
EHDNC:	46.99 GeV
PLACE:	60
CEXIT:	1
SHEND:	50

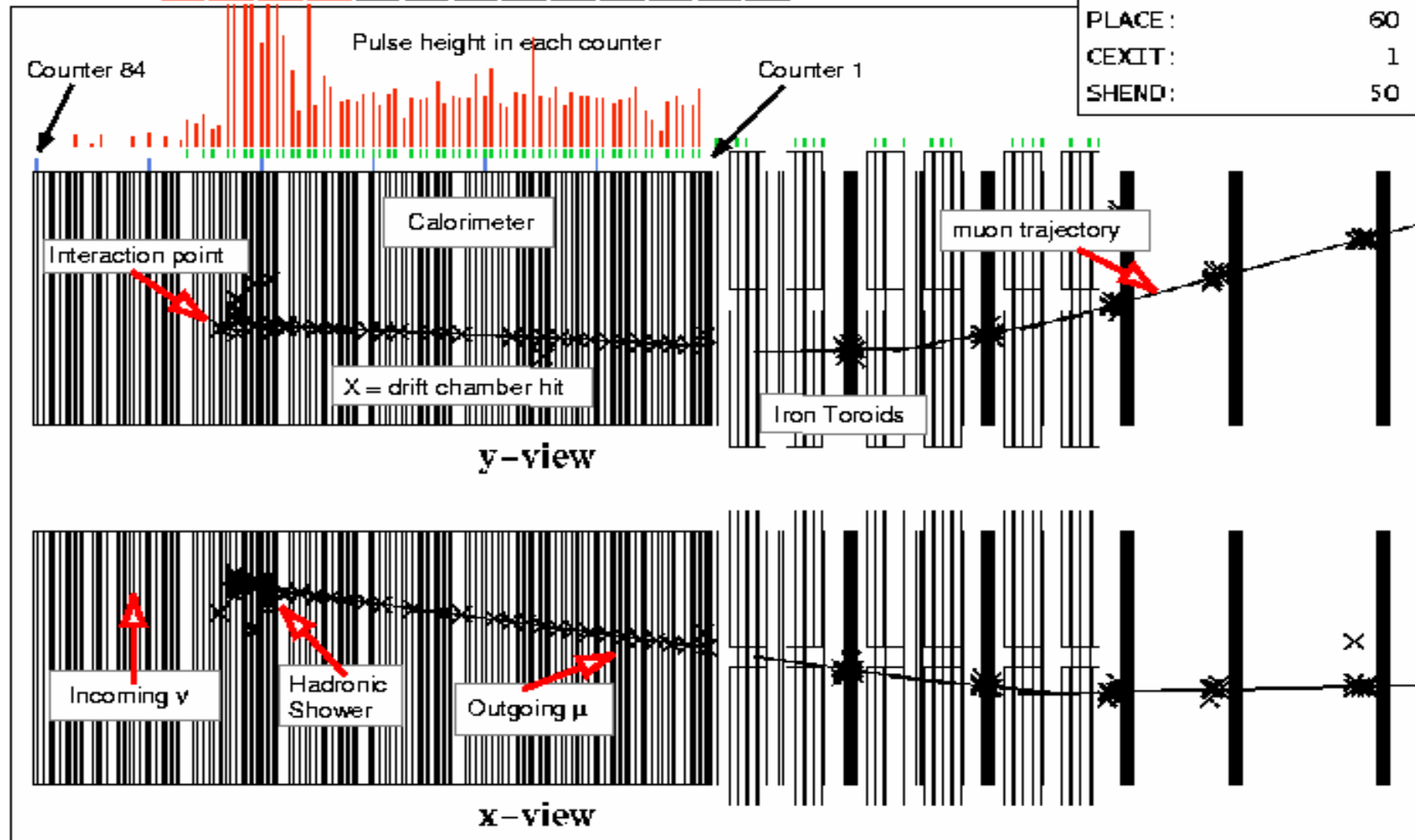

# Tracking Chambers

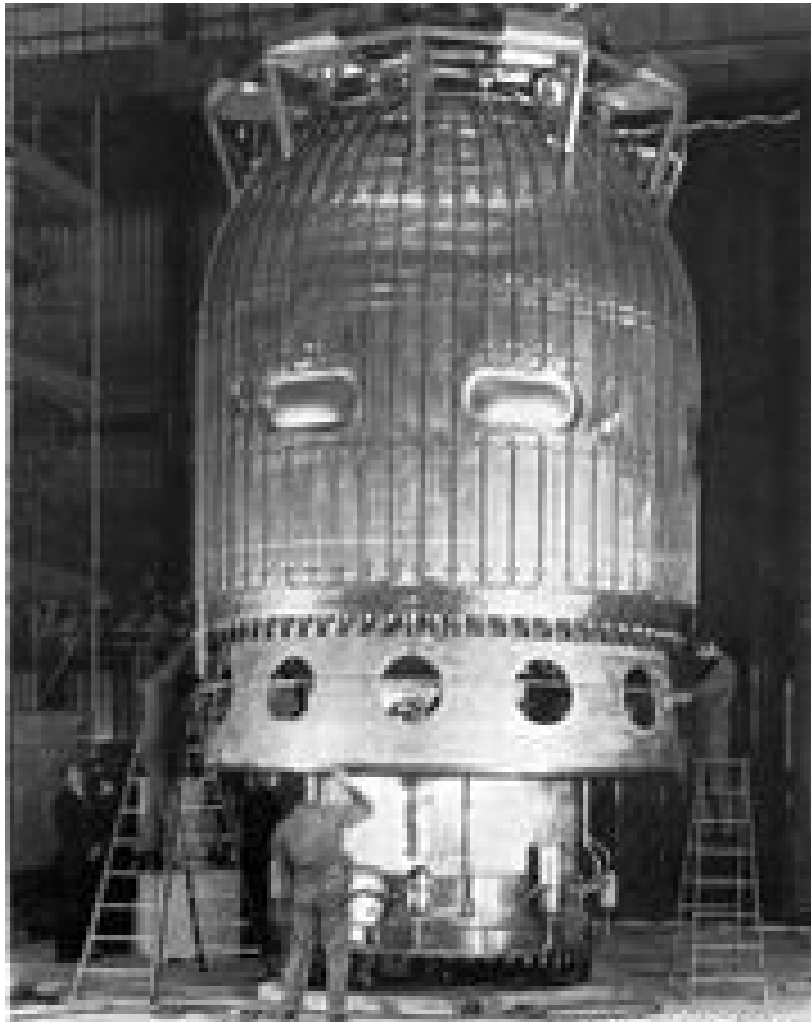
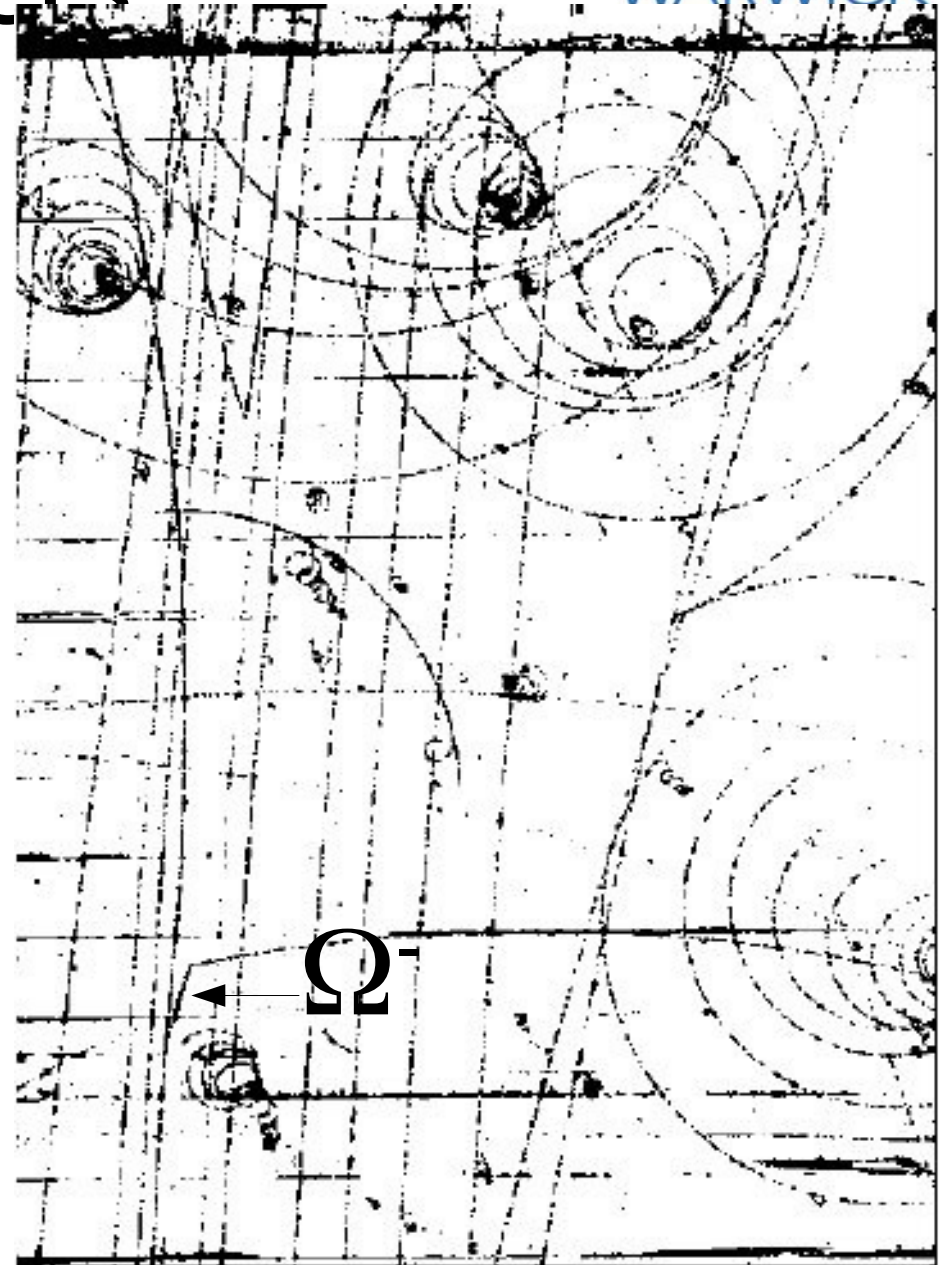

Photo: CERN

BEBC Chamber



# NOMAD

Electronic tracking : NOMAD, CHORUS, BEBC, ICARUS

CERN

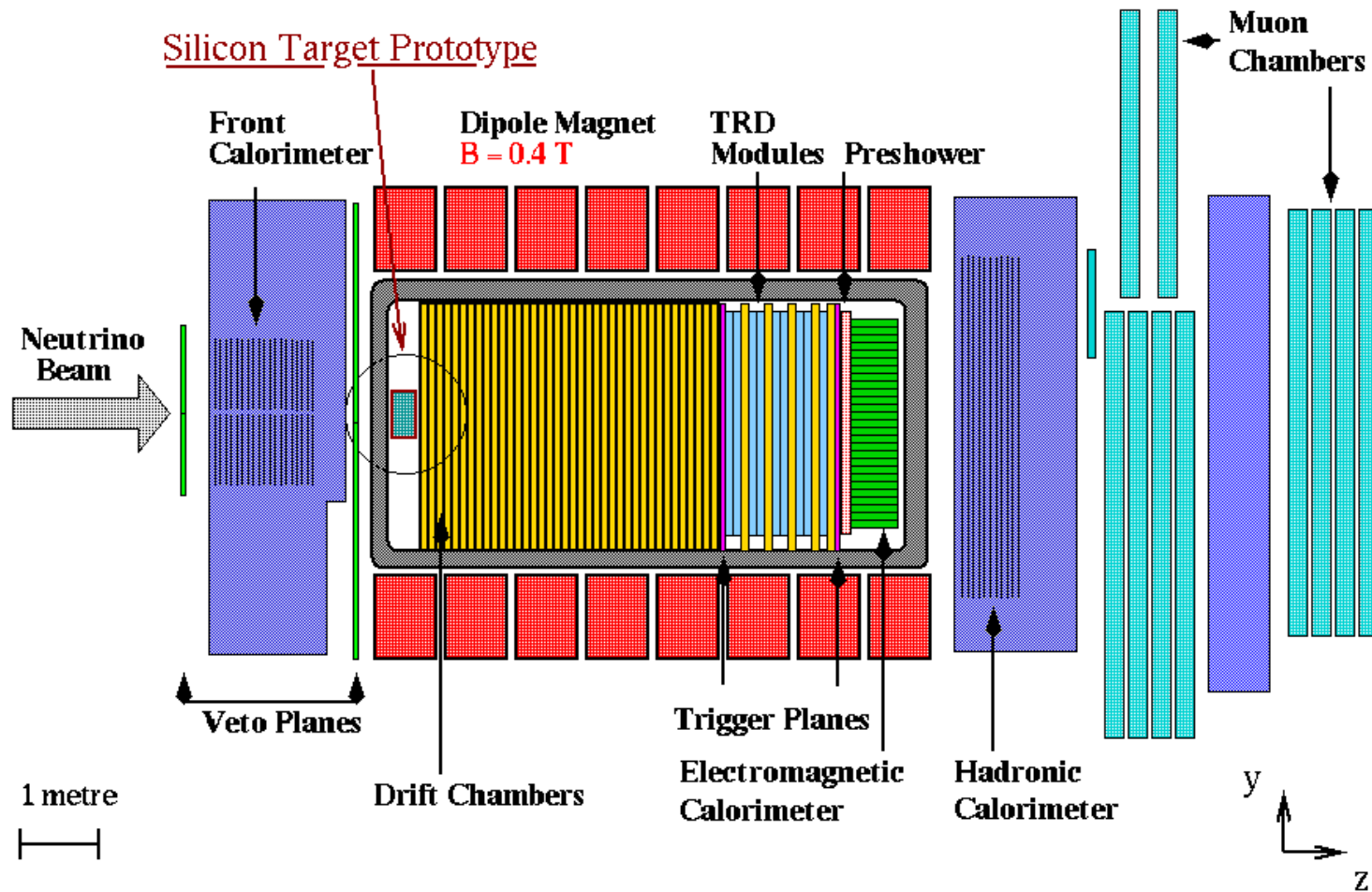

Target was a set of drift chambers with inset carbon planes

# NOMAD Event Display

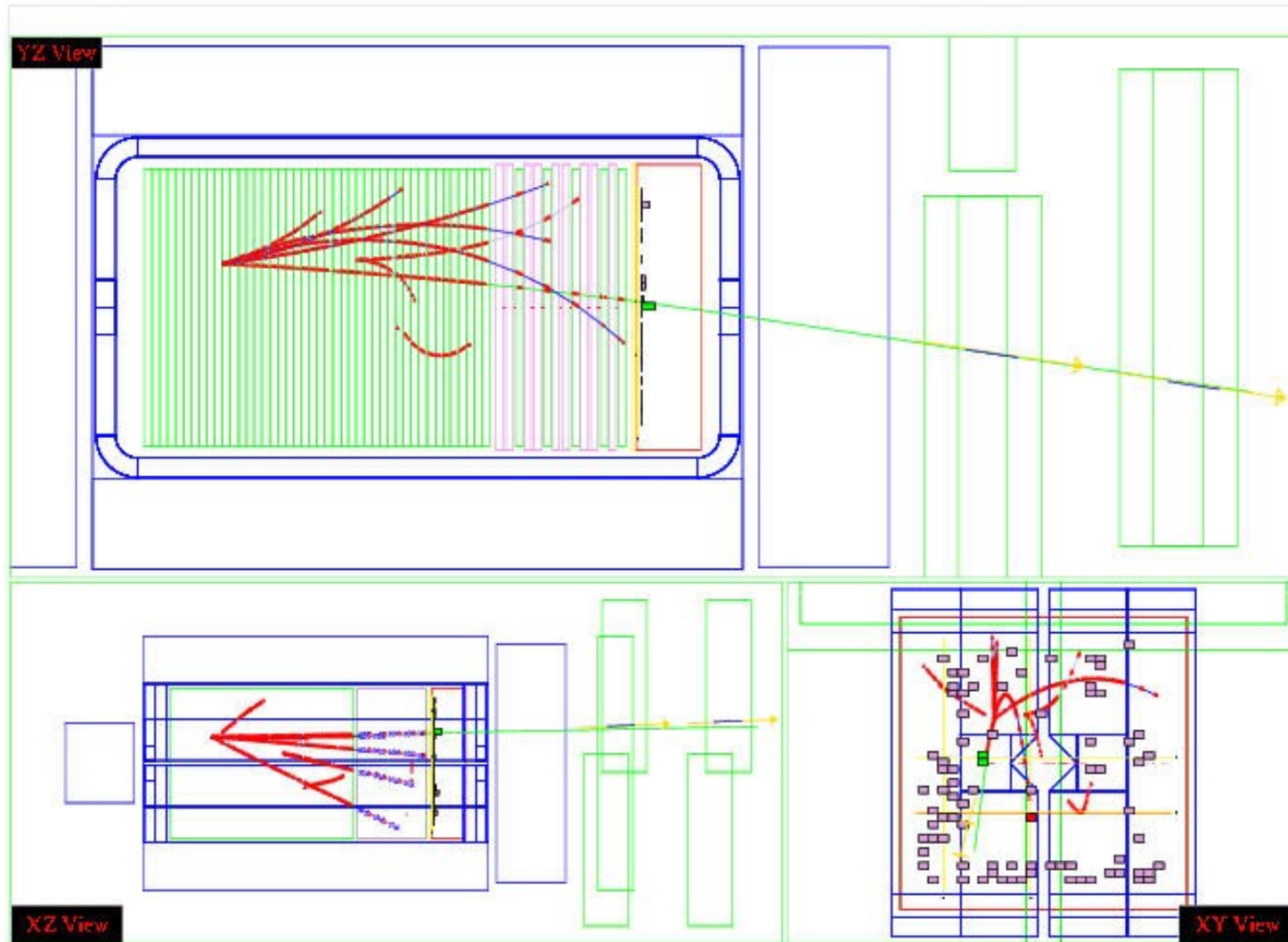

# ICARUS

Huge liquid argon TPC. Bubble chamber like imagery and fully active calorimetry

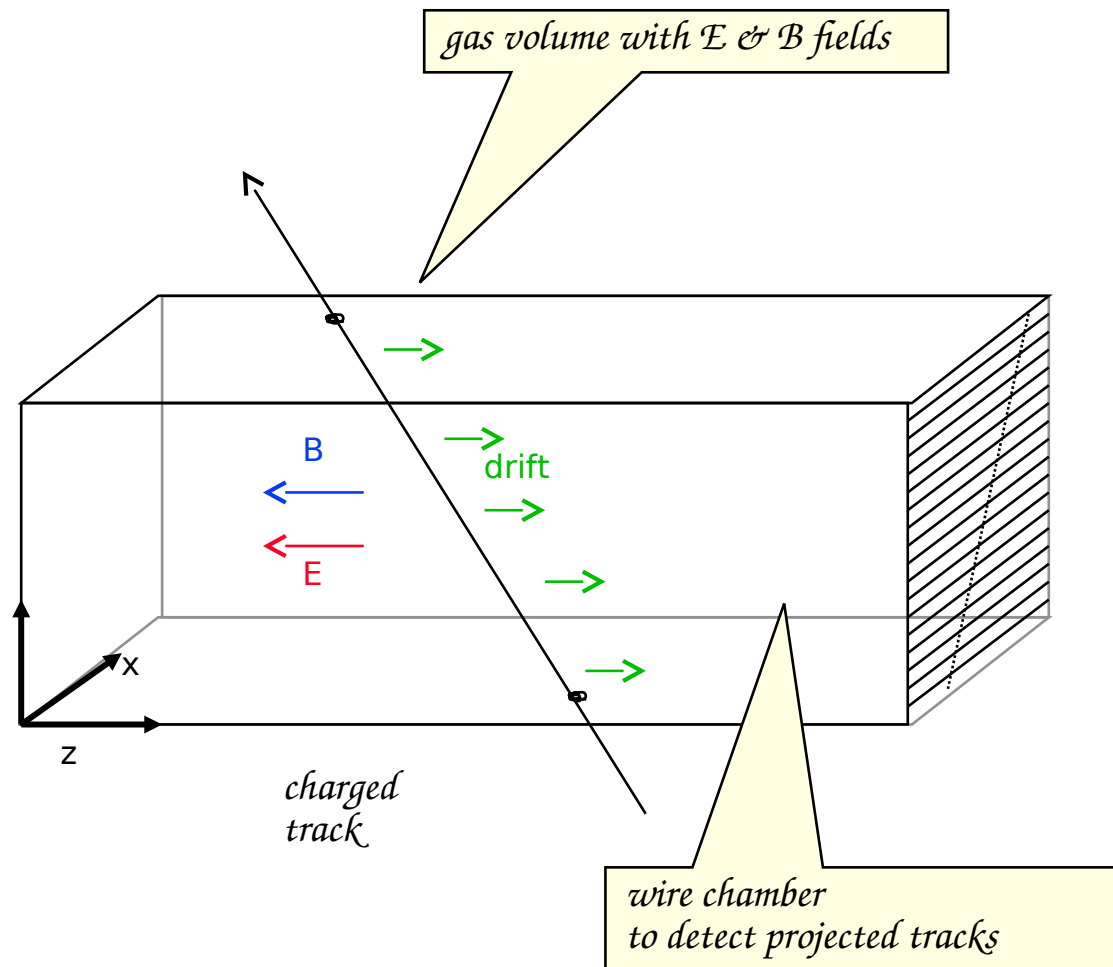

# ICARUS

128 readout wires  
2.54 mm wire pitch

collection view

time (400 ns/sample)  
46 cm max. drift distance



CERN  $\nu$ -beam

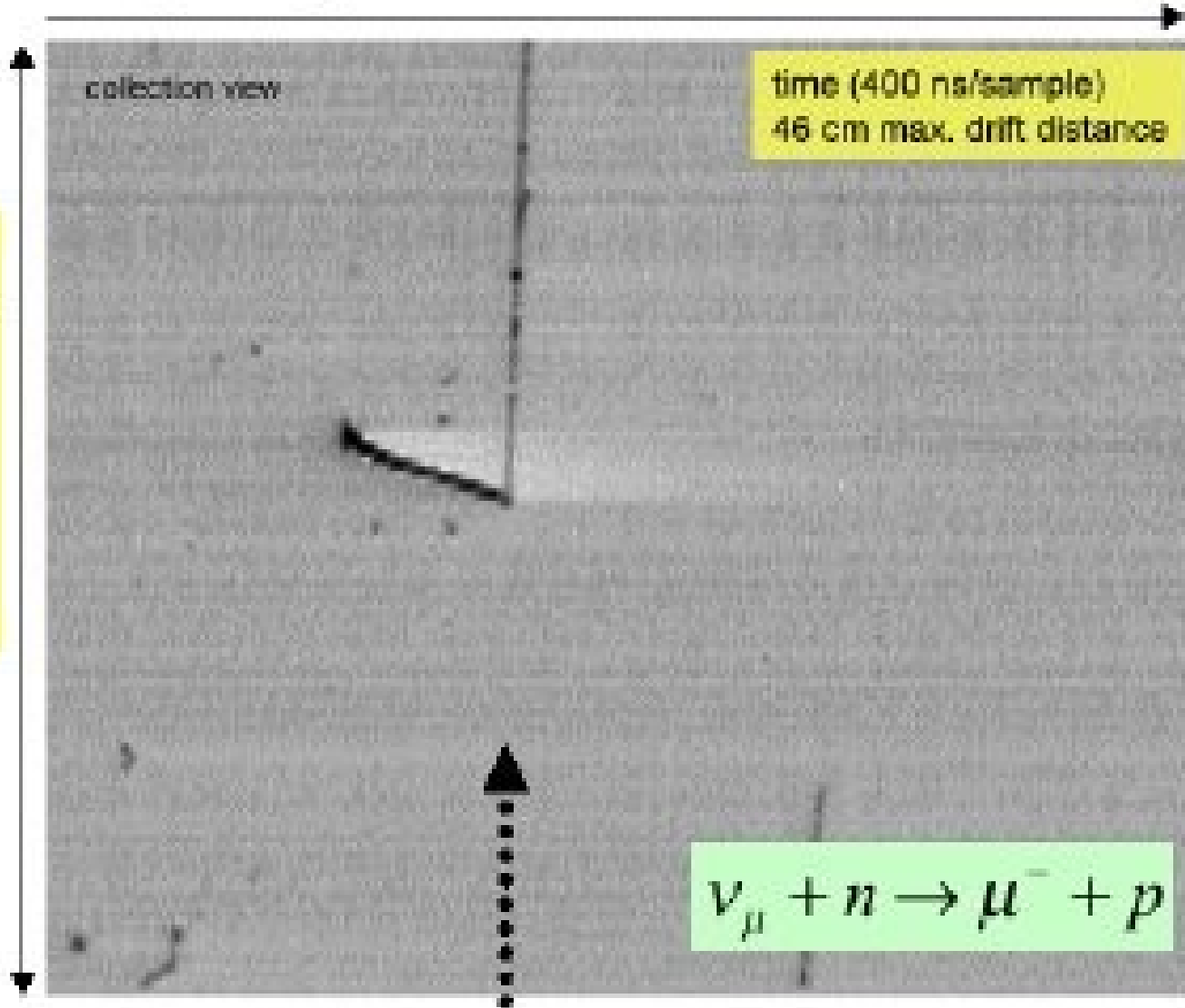

# Water Cerenkov

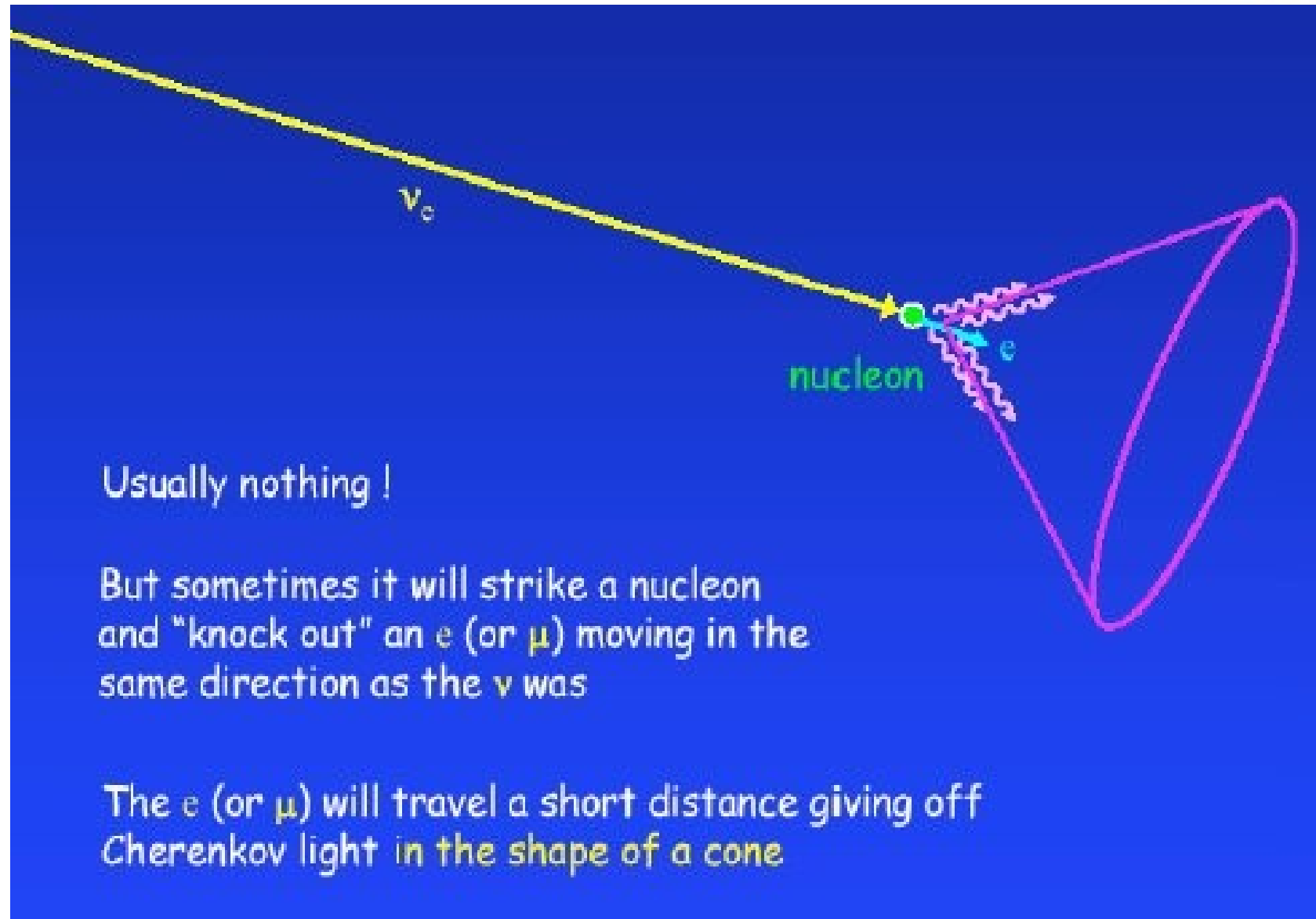

# Principle of operation

- Cerenkov light detected as a ring or circle by PMTs
- Vertex from timing
- Direction from cone
- Energy from summed light
- No neutrals or charged particles under Cerenkov threshold
- Low multiplicity events

# Super-Kamiokande

## Super-Kamiokande



### SK-1 1996 - 2001

- 22.5 kton fiducial mass (2m from wall)
- 11146 50-cm photomultiplier tubes
- 40% photocathode coverage
- 1885 20-cm pmts in outer detector

### SK-2 January 2003 - October 2005

- 5182 PMTs, mostly recovered from accident
- ~19% coverage  
with acrylic shields →
- outer detector  
fully restored
- K2K beam resumed



### SK-3 March 2006 +

- original coverage  
to be restored
- T2K off-axis beam from J-PARC

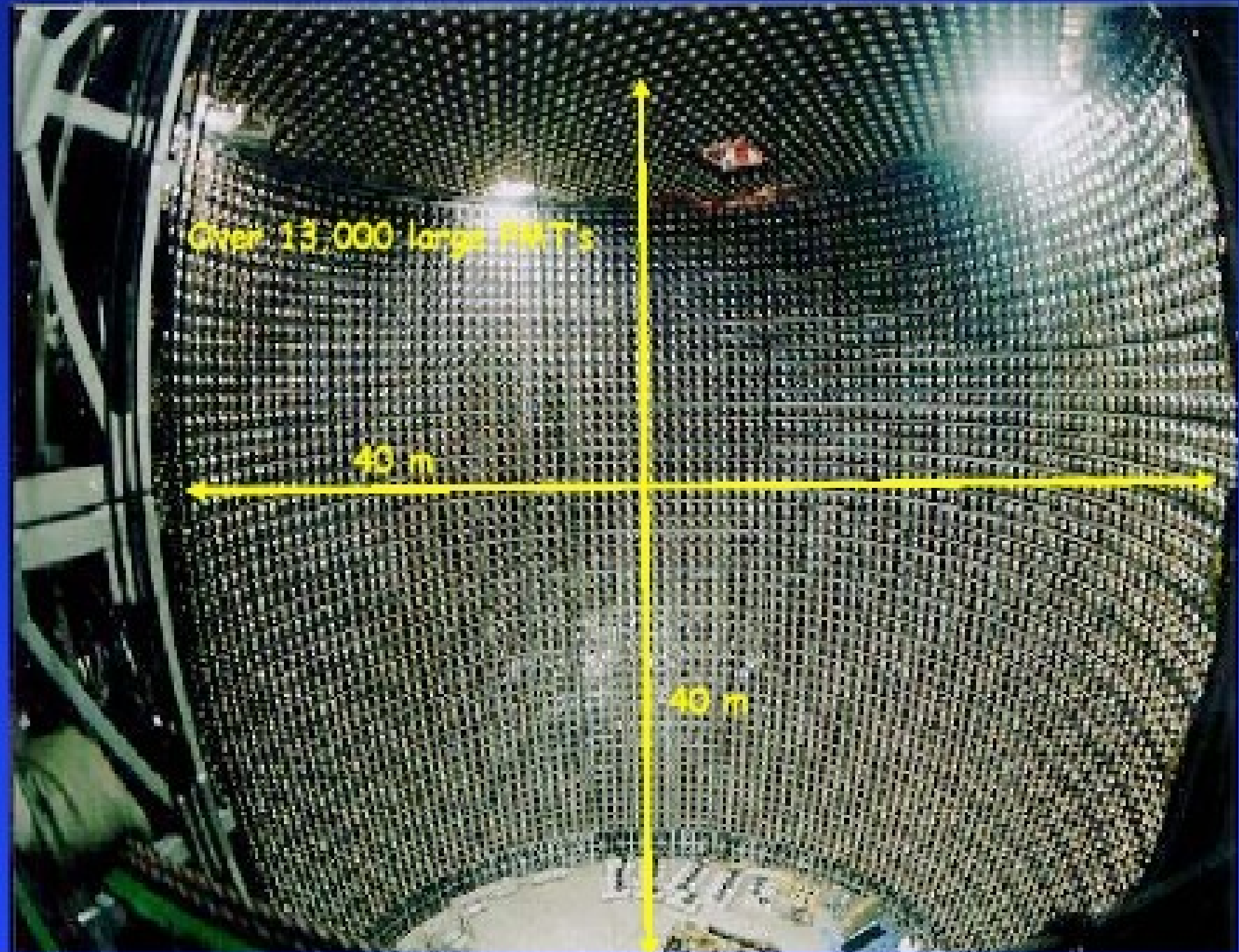

Over 13,000 large PMT's

40 m

40 m

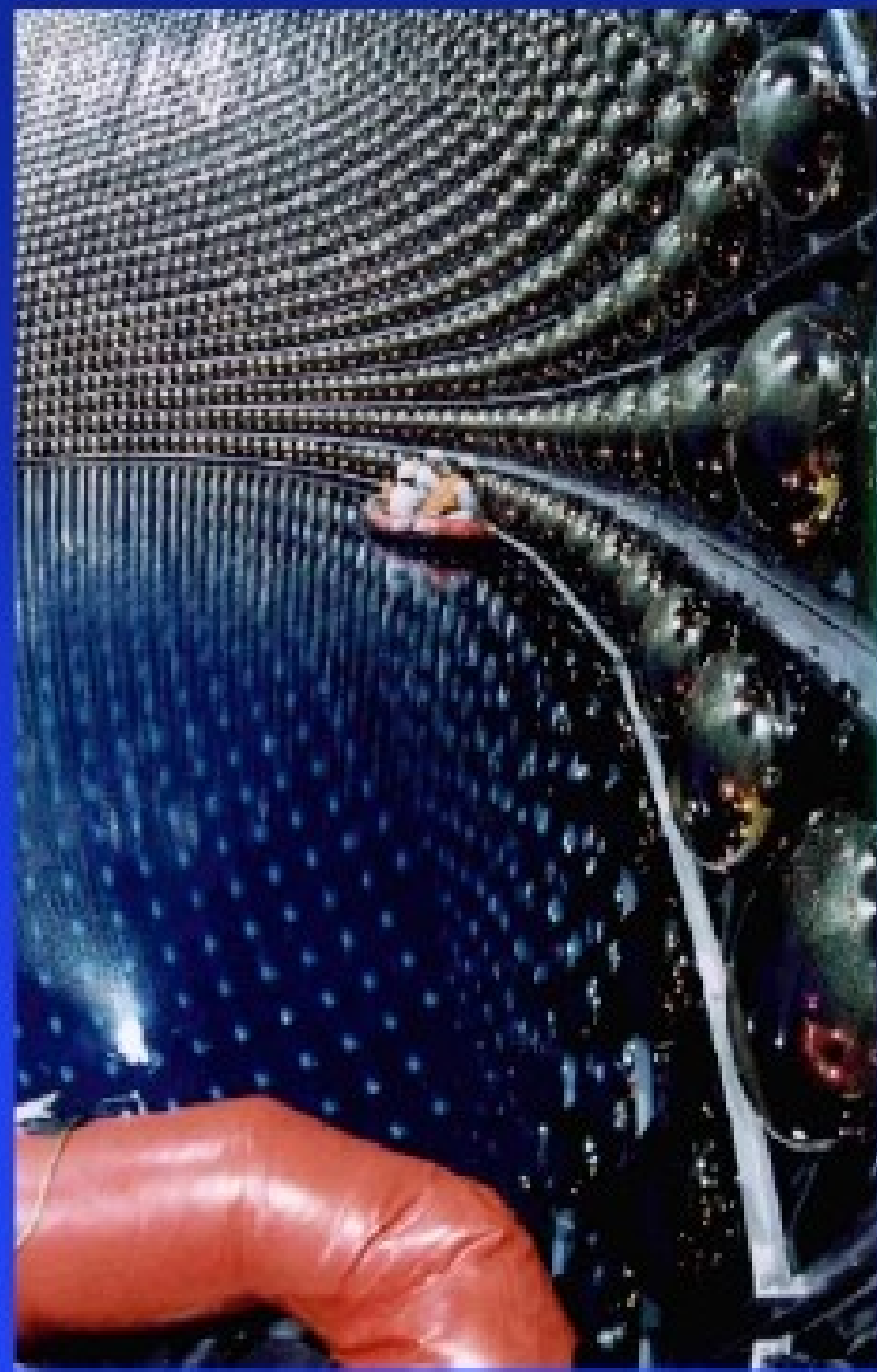
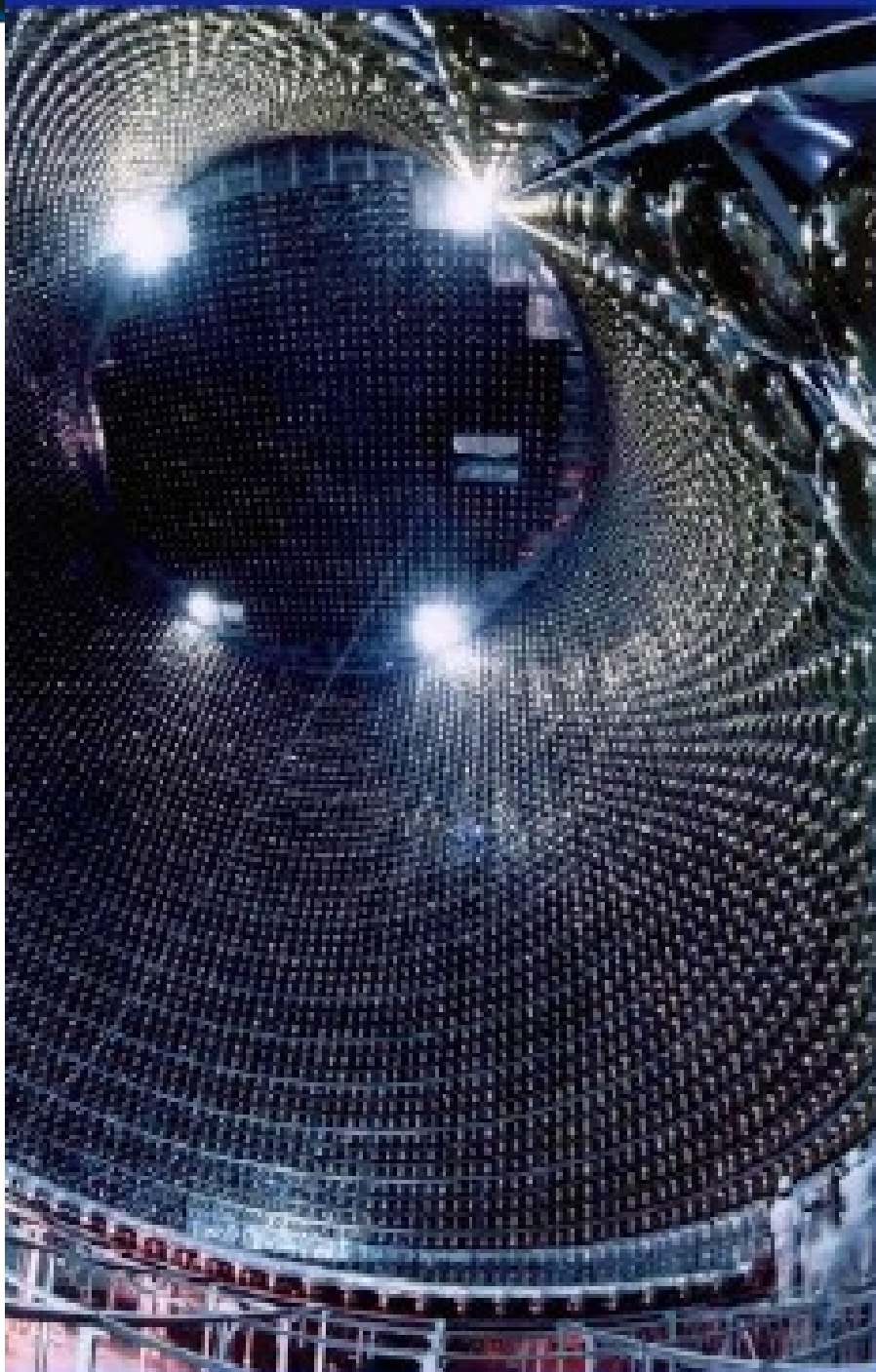

# Example

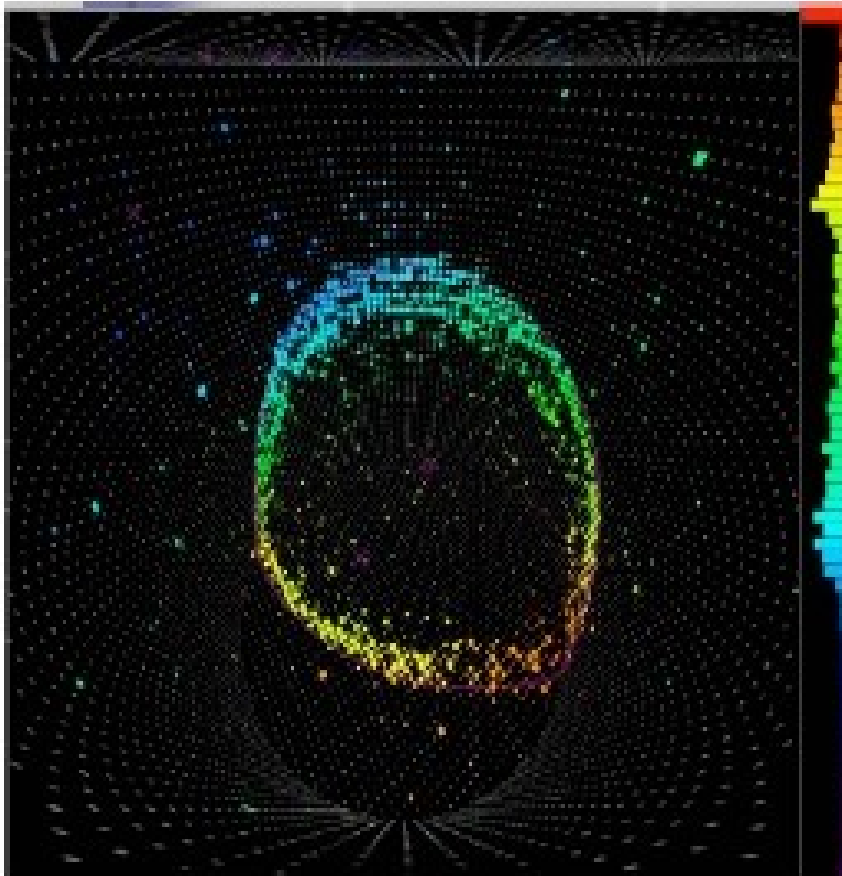

Stopping muon

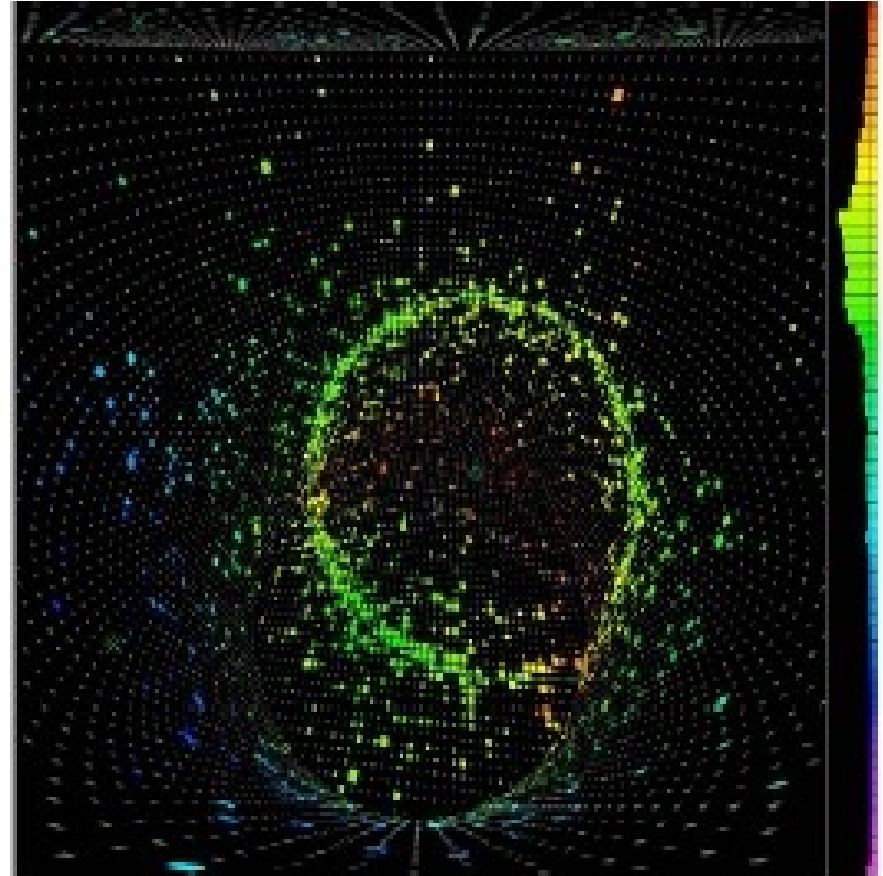

Electron

# Neutrino Interactions

*In which neutrinos interact elastically,  
semi-elastically and inelastically*

# Neutrinos in the Standard Model

Charged-Current (CC) Interactions      Neutral-Current (NC) Interactions

Neutrinos

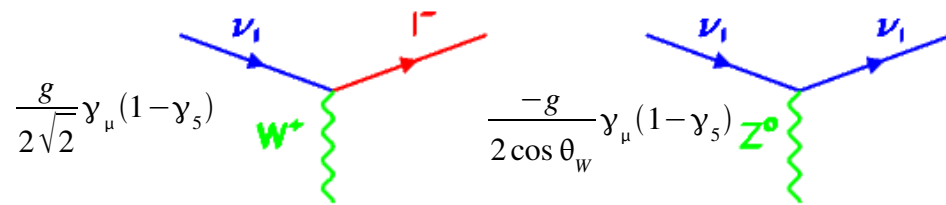

Anti-Neutrinos



Quarks

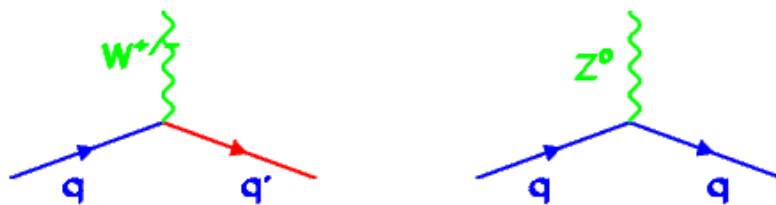

Flavor Changing

Flavor Conserving

W exchange gives CC  
Z exchange gives NC

In CC the flavour of the outgoing lepton determines flavour of neutrino; charge of lepton determines if neutrino or antineutrino

Neutrinos are special in the Standard Model – only fermion that couples only to the weak current

Z0 also couples to right handed (chiral) singlets

# Scattering Variables

Most interactions described in terms of scattering variables based on Lorentz invariants

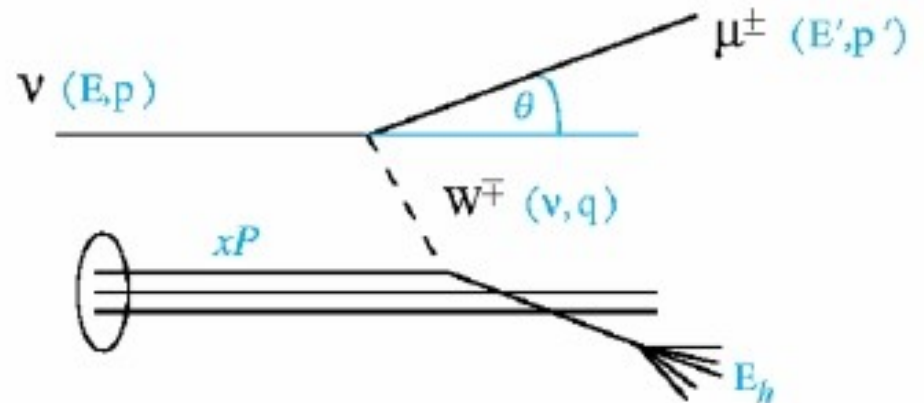

$E', \theta, E_h$  are measured

$$4\text{-Momentum transfer}^2: Q^2 = -q^2 = -(p - p')^2 \approx (4 E' E \sin^2 \theta / 2)_{lab}$$

$$\text{Energy transfer: } \nu = (q \cdot P) / M_T = (E - E')_{lab} = (E_h - M_T)_{lab}$$

$$\text{Inelasticity: } y = (q \cdot P) / (p \cdot P) = (E_h - M_T)_{lab} / (E_h + E')_{lab}$$

$$\text{Bjorken scaling variable } x = Q^2 / 2 M_T \nu$$

$$\text{Recoil Mass}^2: W^2 = (q + P)^2 = M_T^2 + 2 M_T \nu - Q^2$$

$$\text{CM Energy: } s = (p + P)^2 = M_T^2 + Q^2 / xy$$

# Neutrino-Nucleon Interactions in a Nutshell

## CC - $W^\pm$ exchange

- Quasi-elastic Scattering  
Target changes but no breakup  
 $\nu_\mu + n \rightarrow \mu^- + p$
- Coherent/Diffractive production  
Target unchanged  
 $\nu_\mu + n \rightarrow \mu^- + n + \pi^+$
- Nuclear resonance production  
Target goes to excited state and decays  
 $\nu_\mu + n \rightarrow \mu^- + p + \pi^0$  ( $N^*$  or  $\Delta$ )  
 $n + \pi^+$
- Deep Inelastic Scattering  
Target breaks up  
 $\nu_\mu + \text{quark} \rightarrow \mu^- + \text{quark}'$

$q^2$

## NC - $Z^0$ exchange

- Elastic Scattering  
Target unchanged  
 $\nu_\mu + n \rightarrow \nu_\mu + n$
- Coherent/Diffractive production  
Target unchanged  
 $\nu_\mu + N \rightarrow \nu_\mu + N + \pi^0$
- Nuclear resonance production  
Target goes to excited state and decays  
 $\nu_\mu + N \rightarrow \nu_\mu + N + \pi$  ( $N^*$  or  $\Delta$ )
- Deep Inelastic Scattering  
Target breaks up  
 $\nu_\mu + \text{quark} \rightarrow \nu_\mu + \text{quark}$

# Neutrino Electron CC Scattering

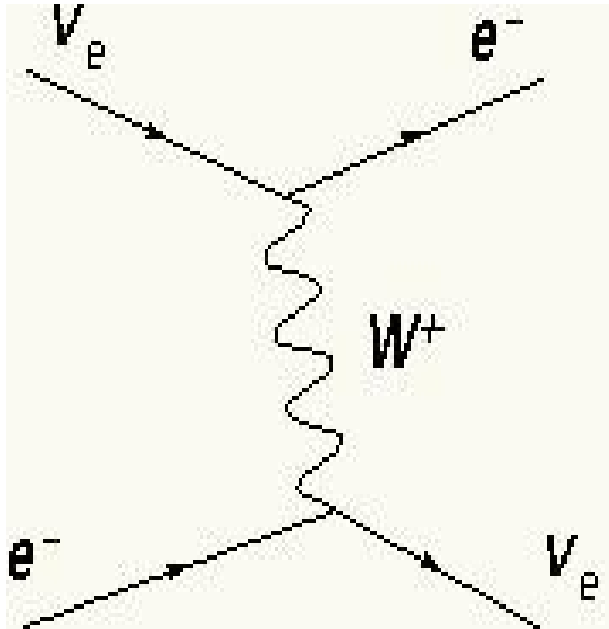

$$L = \frac{G_F}{\sqrt{2}} [\bar{\nu}_e \gamma^\mu (1 - \gamma_5) e] [\bar{\mu} \gamma_\mu (1 - \gamma_5) \nu_\mu]$$

$$\frac{d\sigma_{CC}(\nu_\mu e)}{dy} = \frac{G_F^2 s}{\pi} \frac{M_W^2}{q^2 - M_W^2} \sim \frac{G_F^2 s}{\pi}$$

$$\sigma_{CC}(\nu_\mu e) = \frac{G_F^2 s}{\pi} = 1.7 \times 10^{-41} \left( \frac{E_\nu}{1 \text{ GeV}} \right) \text{ cm}^2$$

NB Neutrino always couples to the negative charged lepton

- proportional to  $E_\nu$
- General property of a point interaction with no structure
- V-A at both vertices

# Neutrino Electron NC Scattering

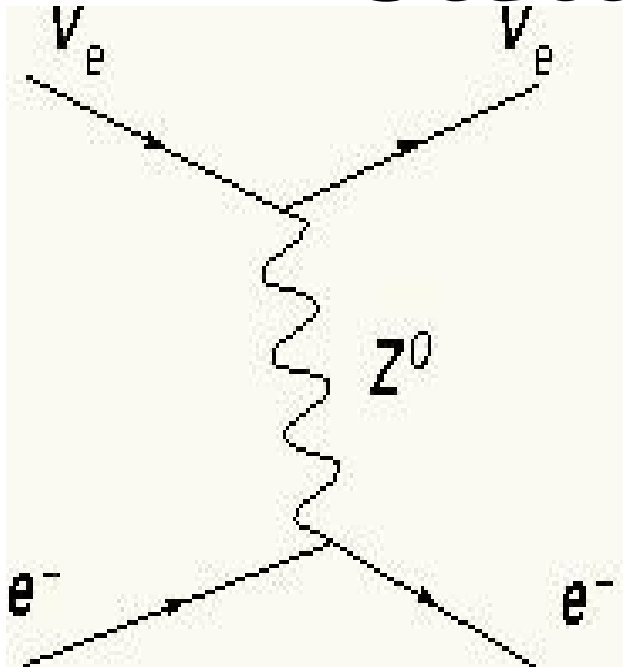

$$L = \frac{1}{\sqrt{2}} [\bar{\nu}_\mu \gamma^\mu (1 - \gamma_5) \nu_\mu] [\bar{e} \gamma_\mu (g_V - g_A \gamma_5) e]$$

mixture

$$g_L \bar{e} \gamma_\mu (1 - \gamma_5) e + g_R \bar{e} \gamma_\mu (1 + \gamma_5) e$$

Left handed

Right handed

$$g_L = \frac{1}{2}(g_V + g_A) = -\frac{1}{2} + \sin^2 \theta_W \quad g_R = \frac{1}{2}(g_V - g_A) = \sin^2 \theta_W$$

$Z^0$  can couple right handed fermion singlets as well.

$$\frac{d\sigma_{NC}(\nu_\mu e)}{dy} = \frac{G_F^2 s}{\pi} \frac{m_Z^2}{q^2 - m_Z^2} [g_L^2 + g_R^2 (1-y)^2]$$

$$\frac{d\sigma_{NC}(\bar{\nu}_\mu e)}{dy} = \frac{G_F^2 s}{\pi} \frac{m_Z^2}{q^2 - m_Z^2} [g_L^2 (1-y)^2 + g_R^2]$$

# Angular spectra

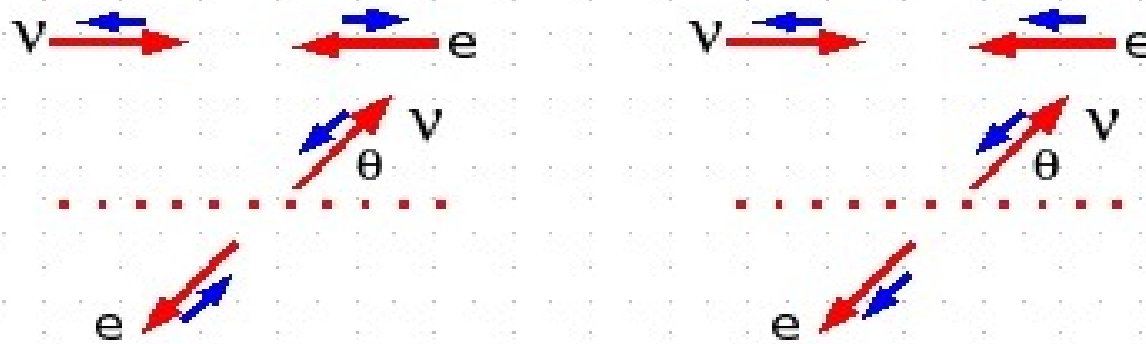

$$J=0: \frac{d\sigma_{NC}}{d\cos\theta} \propto \text{CONST}$$

$$J=1: \frac{d\sigma_{NC}}{d\cos\theta} \propto \left(\frac{1+\cos\theta}{2}\right)^2$$

Isotropic

No back scattering  
Helicity mismatch

$$\frac{d\sigma_{NC}(\nu_\mu e)}{dy} \sim [g_L^2 + g_R^2(1-y)^2]$$

$Y=0 \Rightarrow$  forward scattering. Both  $J=0, J=1$  can occur  
 $Y=1 \Rightarrow$  backward scattering. Only  $J=0$  can happen.

# Neutrino cross sections

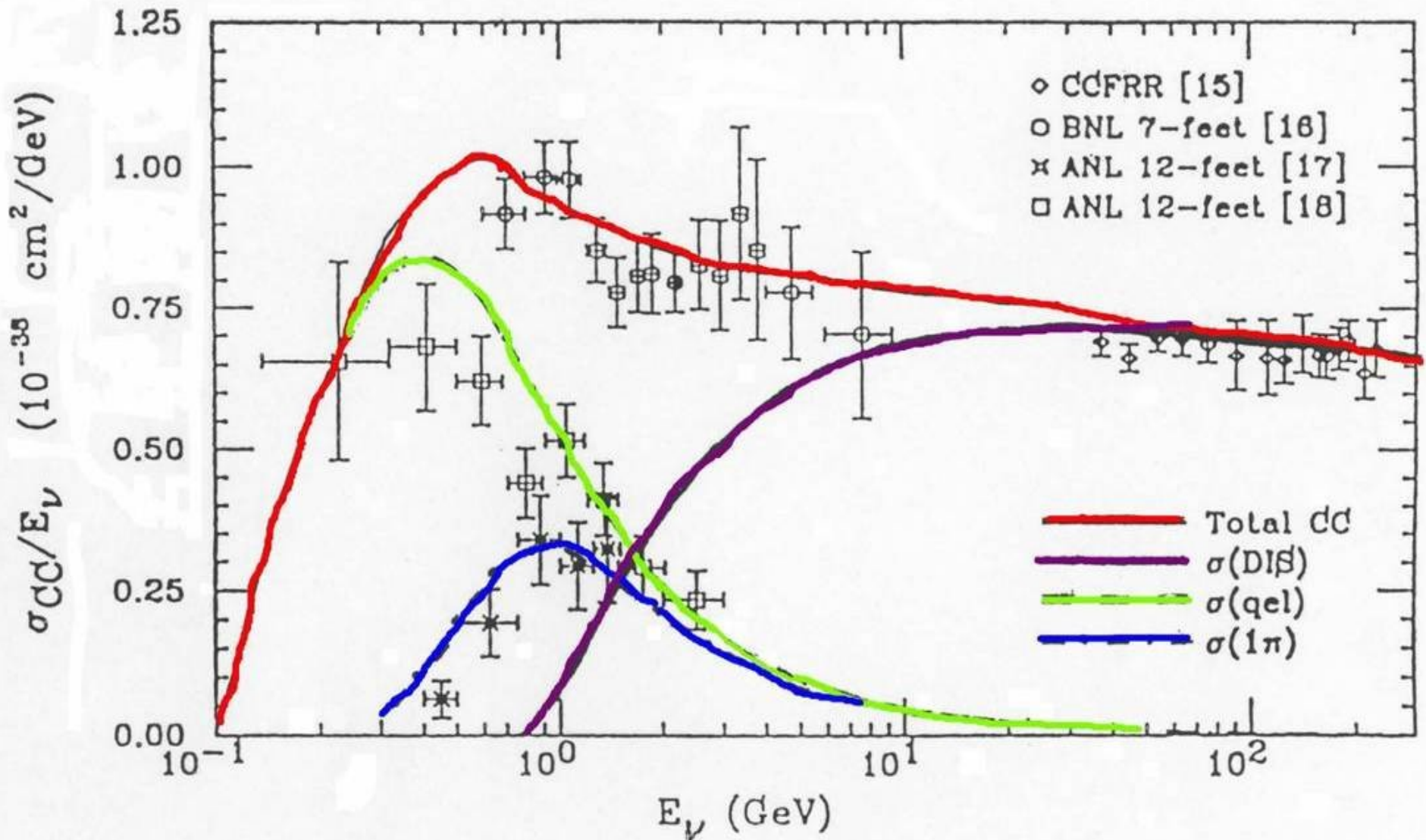

# Quasi-elastic Scattering

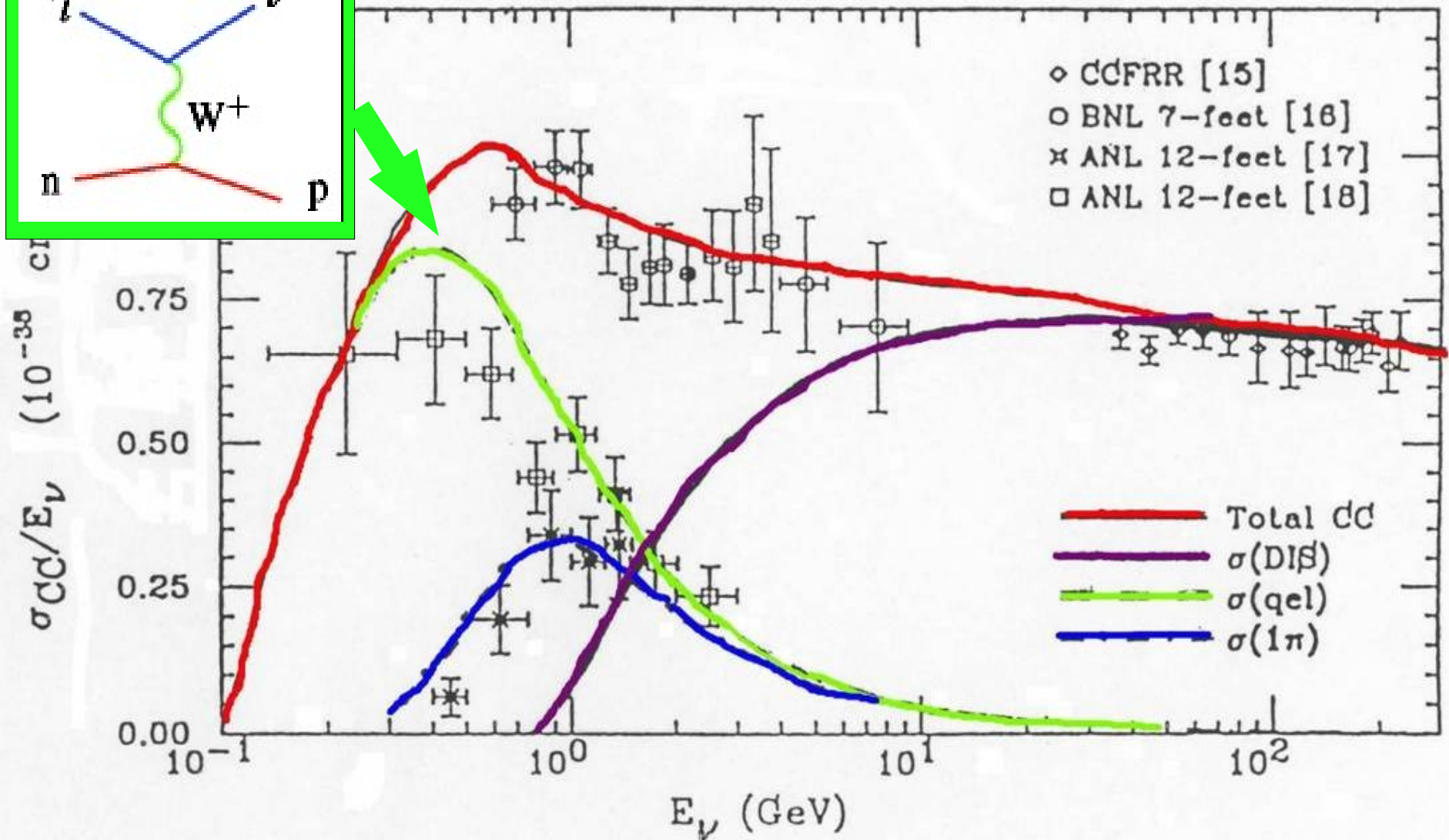
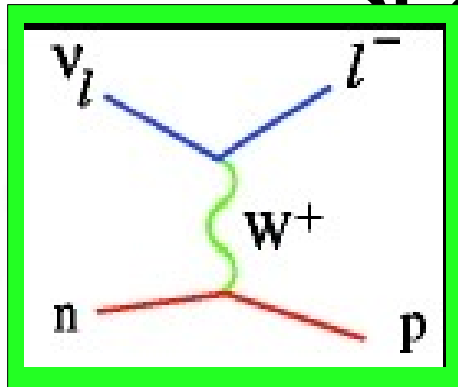

# Quasi-elastic Scattering

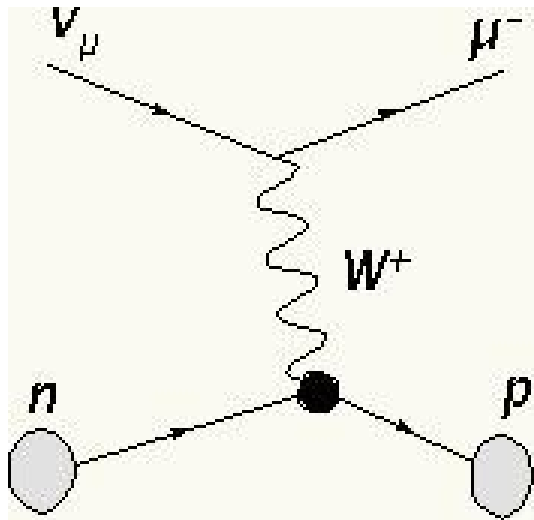

Now we have a complex hadronic target to think about

$$M = \frac{G_F \cos \theta_c}{\sqrt{2}} [\bar{\mu} \gamma_\alpha (1 - \gamma_5) \nu] [\bar{p} \gamma^\alpha (F_V(Q^2) + F_A(Q^2) \gamma_5) n]$$

Standard V-A

Vector  
Form factor

Axial-vector  
form factor

The form factors must be measured.

Only neutrino interactions can determine  $F_A$ .

Dipole  
Approximation

$$F_{V,A}(Q^2) = \frac{F_{V,A}(0)}{\left(1 - \frac{q^2}{M_{V,A}^2}\right)^2}$$

$$F_V(0) = 1; M_V = 0.84 \text{ GeV}$$

$$F_A(0) = g_A/g_V = -1.267$$

$$M_A \approx 1.026 \pm 0.02$$

# Experimental signature

WARWICK

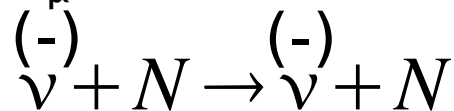
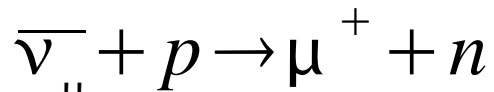
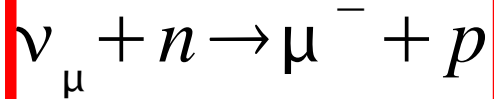

Proton id from dEdx  
Muon id from range  
Two-body so angles  
are known if  $E_{\mu}$  is  
known

$$E_{\nu} = \frac{m_N E_{\mu} - m_{\mu}^2 / 2}{m_N - E_{\mu} + p_{\mu} \cos \theta_{\mu}}$$

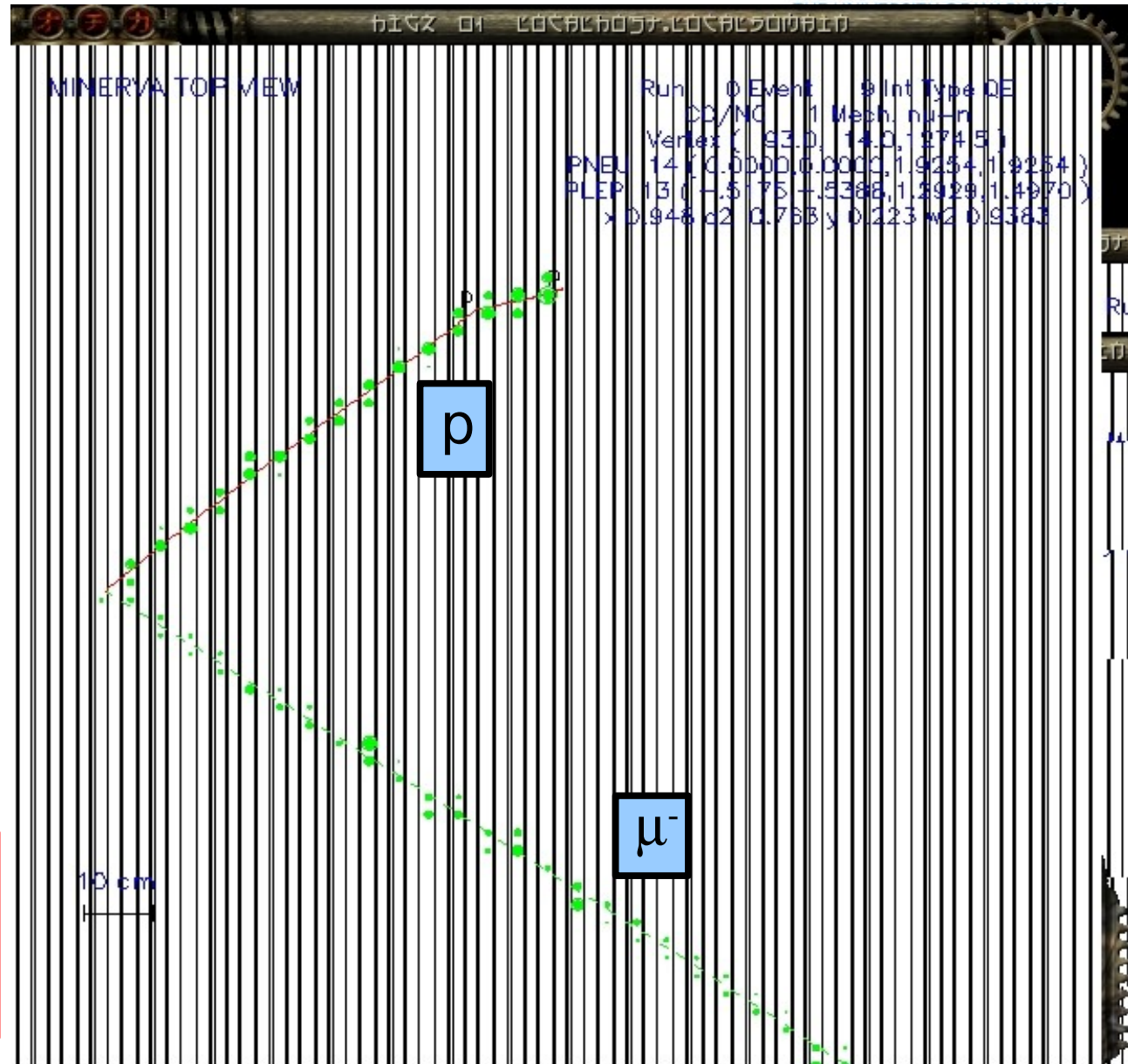

# Importance of CC QE

- Absolute neutrino flux is never known to better than 20-30%
- This makes absolute cross sections hard to measure accurately so experimentalists like to measure cross section ratios

$$R = \frac{\sigma_{process}}{\sigma_{norm}} = \frac{N_{process} * \Phi_{\nu} / \epsilon_{process}}{N_{norm} * \Phi_{\nu} / \epsilon_{norm}}$$

- Ideally, want a well known normalisation cross section
- Would be great to use  $\nu$ -e scattering since the cross section is known to much better than a percent but cross section is too small.
- Next best thing is the CC QE process

# Problems with QE

The CC QE process is the best known neutrino process occurring at a few GeV

# Problems with QE

The CC QE process is the best known neutrino process occurring at a few GeV

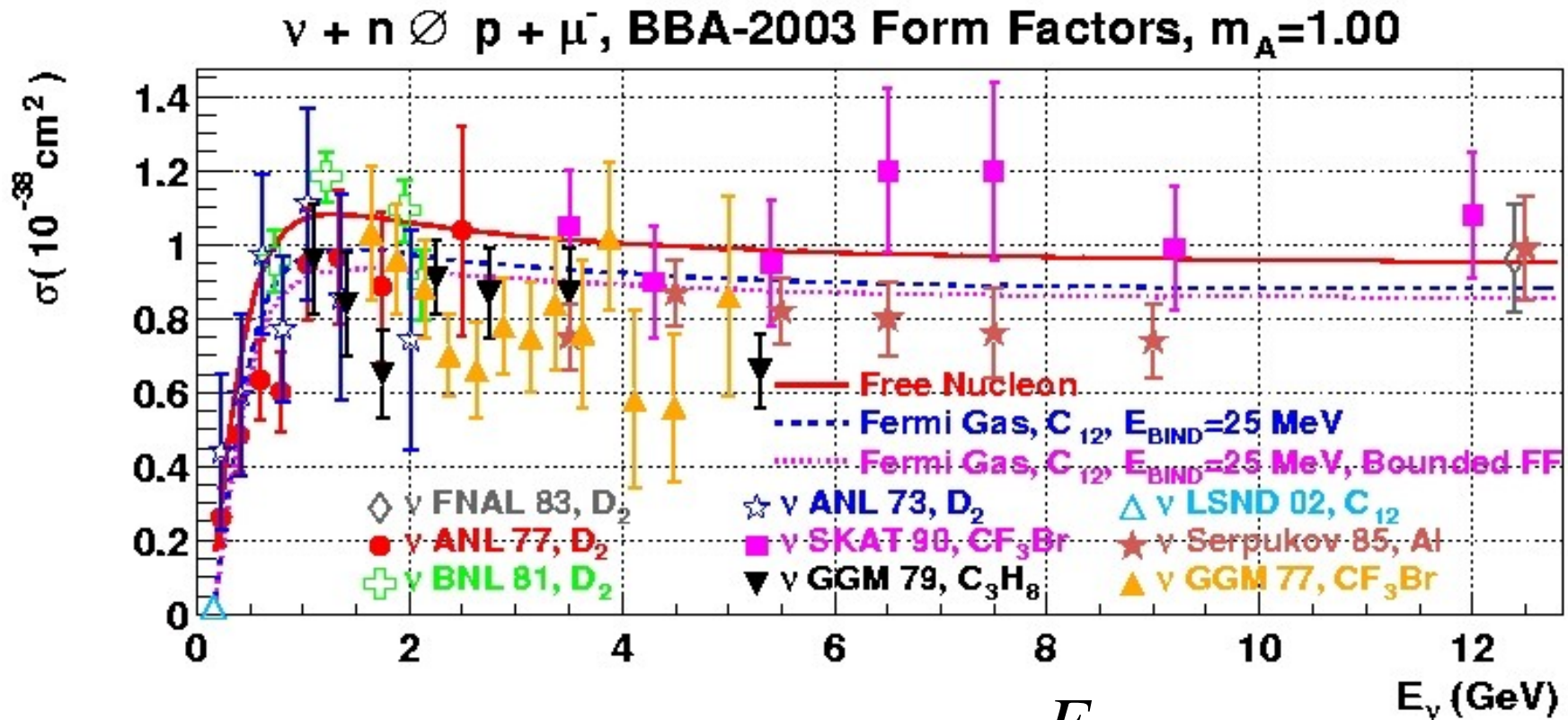

$$\sigma_{QE} \sim 0.975 \times 10^{-38} \left( \frac{E_\nu}{1 \text{ GeV}} \right) \text{ cm}^2$$

1. We are assuming that the initial target nucleon is just sitting still before interaction. Actually in the nucleus it has some initial momentum.

The **Fermi momentum** modifies the scattering angles and momentum spectra of the outgoing final state

2. The outgoing nucleon can interact with the target nucleus.

This **nuclear re-interaction** affects the outgoing nucleon momentum and direction

Theoretical uncertainties are **large**

- At least 10%
- If precise knowledge is needed for a particular target (e.g. Water, hydrocarbon) then measurements are needed
- Last measurements taken in the '70s

# Resonance Production

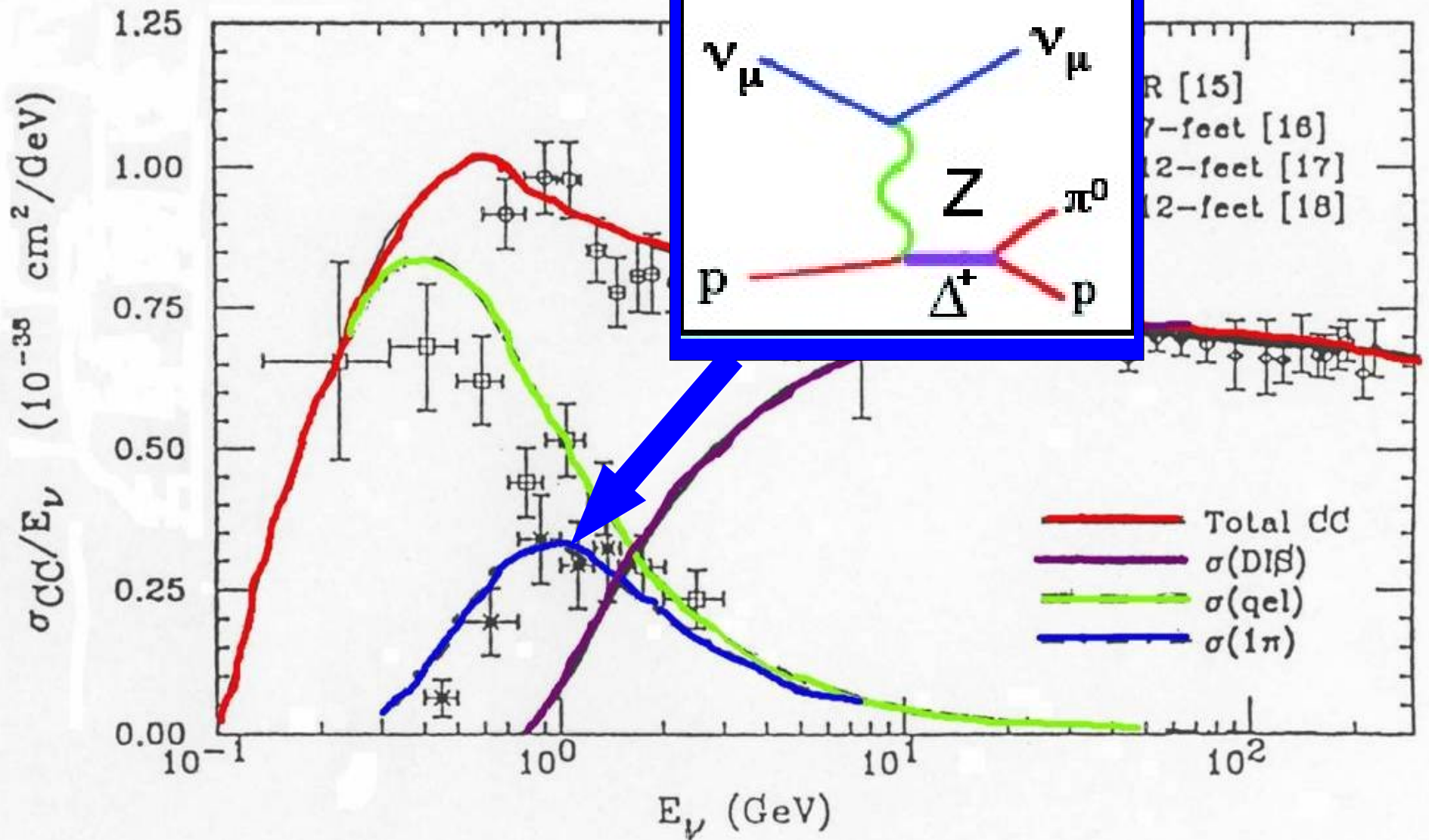
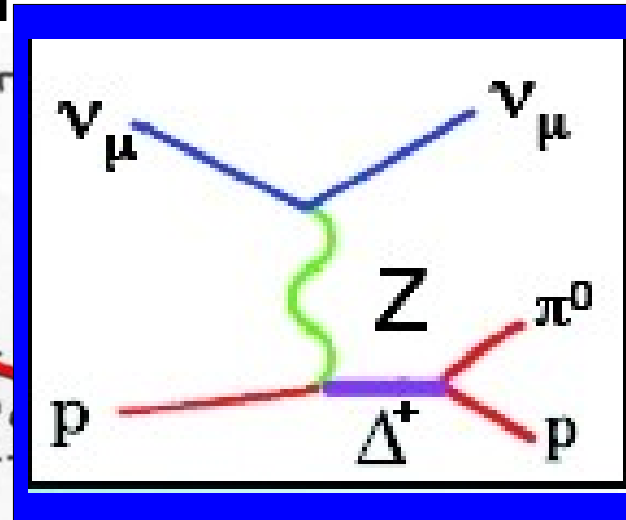

# Resonance production

Between elastic and inelastic scattering regions is a region associated with resonance production.

$$\text{Invariant Mass}^2 = W^2 = M_T^2 + 2 M_T v(1-x)$$

If  $x=1$  then  $W^2 = M_T^2 \Rightarrow$   
(Quasi)-elastic scattering

$$W^2 = (M_T + m_\pi)^2, (M_T + 2m_\pi)^2, \dots$$

Incredibly complicated region  
with different angular  
momentum, spin,  
parity resonances

dominated by the  $N^*$   
( $S=0, l=1/2$ ) and  $\Delta$  ( $S=0, l=3/2$ )

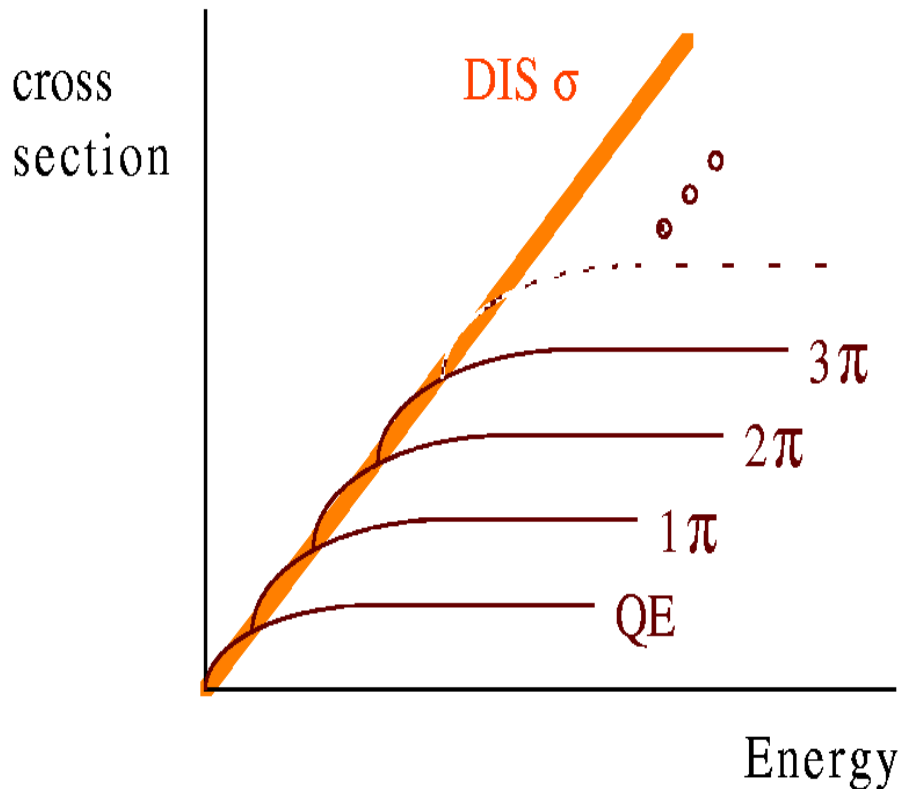

# Example

Particle	$L_{21,2J}$	Overall status	$N\pi$	$N\eta$	$\Delta K$	$\Sigma K$	$\Delta\pi$	$N\rho$	$N\gamma$									
$N(939)$	$P_{11}$	****								$\Delta(1232)$	$P_{33}$	****	****	F				****
$N(1440)$	$P_{11}$	****	****	*			***	*	***	$\Delta(1600)$	$P_{33}$	***	***	o		***	*	**
$N(1520)$	$D_{13}$	****	****	*			****	****	****	$\Delta(1620)$	$S_{31}$	****	****	r		****	****	***
$N(1535)$	$S_{11}$	****	****	****			*	**	***	$\Delta(1700)$	$D_{33}$	****	****	b	*	***	**	***
$N(1650)$	$S_{11}$	****	****	*	***	**	***	**	***	$\Delta(1750)$	$P_{31}$	*	*	i				
$N(1675)$	$D_{13}$	****	****	*	*		****	*	****	$\Delta(1900)$	$S_{31}$	**	**	d	*	*	**	*
$N(1680)$	$F_{15}$	****	****				****	****	****	$\Delta(1905)$	$F_{35}$	****	****	d*		**	**	***
$N(1700)$	$D_{13}$	***	***	*	**	*	**	*	**	$\Delta(1910)$	$P_{31}$	****	****	e	*	*	*	
$N(1710)$	$P_{11}$	***	***	**	**	*	**	*	***	$\Delta(1920)$	$P_{33}$	***	***	n		**		*
$N(1720)$	$P_{13}$	****	****	*	**	*	*	**	**	$\Delta(1930)$	$D_{35}$	***	***	*				**
$N(1900)$	$P_{13}$	**	**					*		$\Delta(1940)$	$D_{33}$	*	*	F				
$N(1990)$	$F_{17}$	**	**	*	*	*			*	$\Delta(1950)$	$F_{37}$	****	****	o	*	****	*	****
$N(2000)$	$F_{15}$	**	**	*	*	*	*	**		$\Delta(2000)$	$F_{35}$	**		r			**	
$N(2080)$	$D_{13}$	**	**	*	*				*	$\Delta(2150)$	$S_{31}$	*	*	b				
$N(2090)$	$S_{11}$	*	*							$\Delta(2200)$	$G_{37}$	*	*	i				
$N(2100)$	$P_{11}$	*	*	*						$\Delta(2300)$	$H_{39}$	**	**	d				
$N(2190)$	$G_{17}$	****	****	*	*	*		*	*	$\Delta(2350)$	$D_{35}$	*	*	d				
$N(2200)$	$D_{15}$	**	**	*	*					$\Delta(2390)$	$F_{37}$	*	*	e				
$N(2220)$	$H_{19}$	****	****	*						$\Delta(2400)$	$G_{39}$	**	**	n				
$N(2250)$	$G_{19}$	****	****	*						$\Delta(2420)$	$H_{311}$	****	****					*
$N(2600)$	$I_{111}$	***	***							$\Delta(2750)$	$I_{313}$	**	**					
$N(2700)$	$K_{113}$	**	**							$\Delta(2950)$	$K_{315}$	**	**					

Different states can interfere in production amplitudes  
Some states do not take part due to helicity structure

# Resonance Region Data

The data is impressively imprecise

CC Single Pion Production

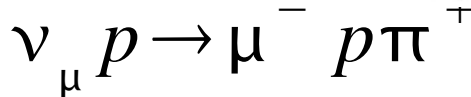
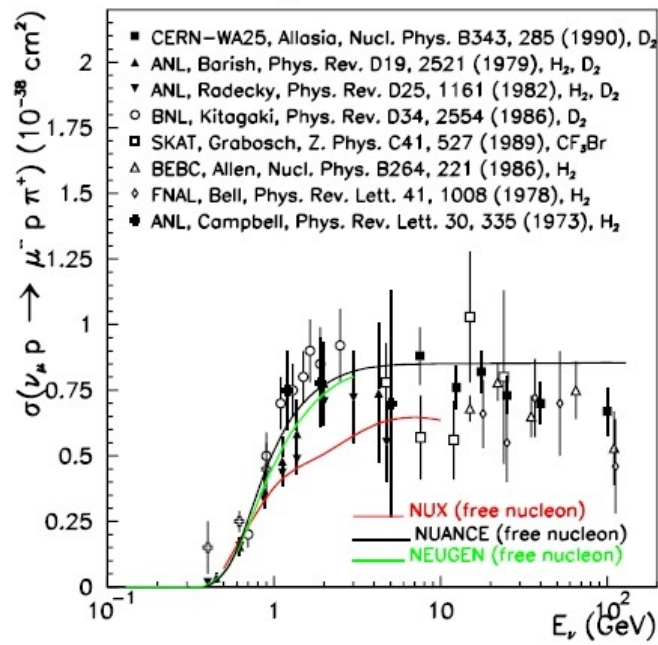

Multi Pion Production

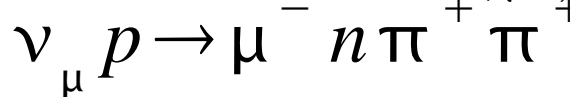
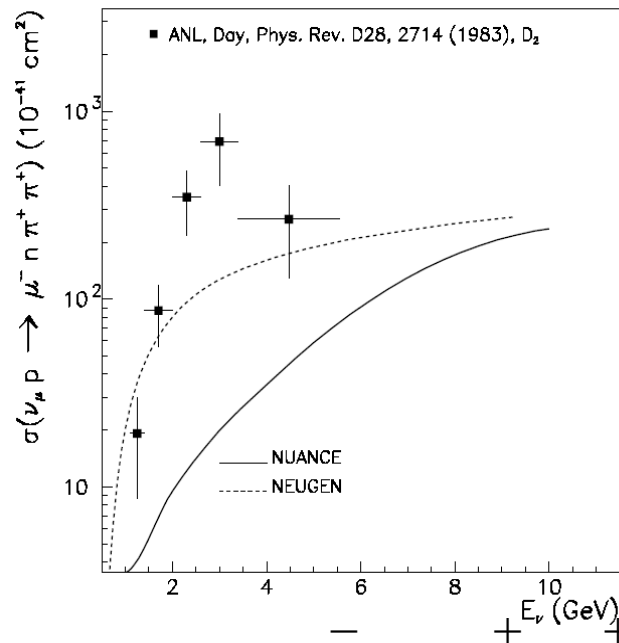

NC Single Pion Production

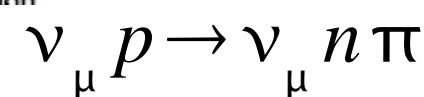
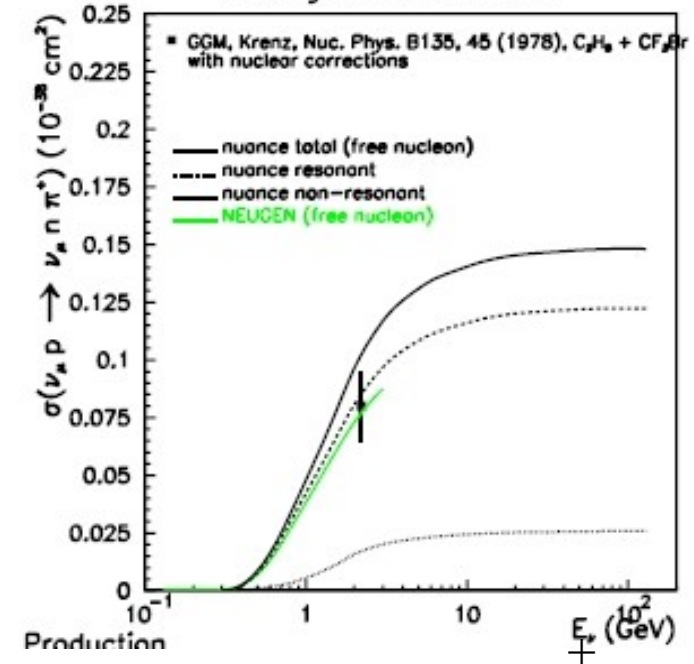

Added complication that the final state pions can (i) scatter (ii) be absorbed (iii) charge exchange within the nucleus before being observed (iv) nucleons rescatter producing  $\pi$

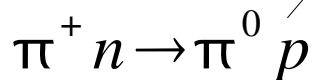

# SciBooNE

WARWICK

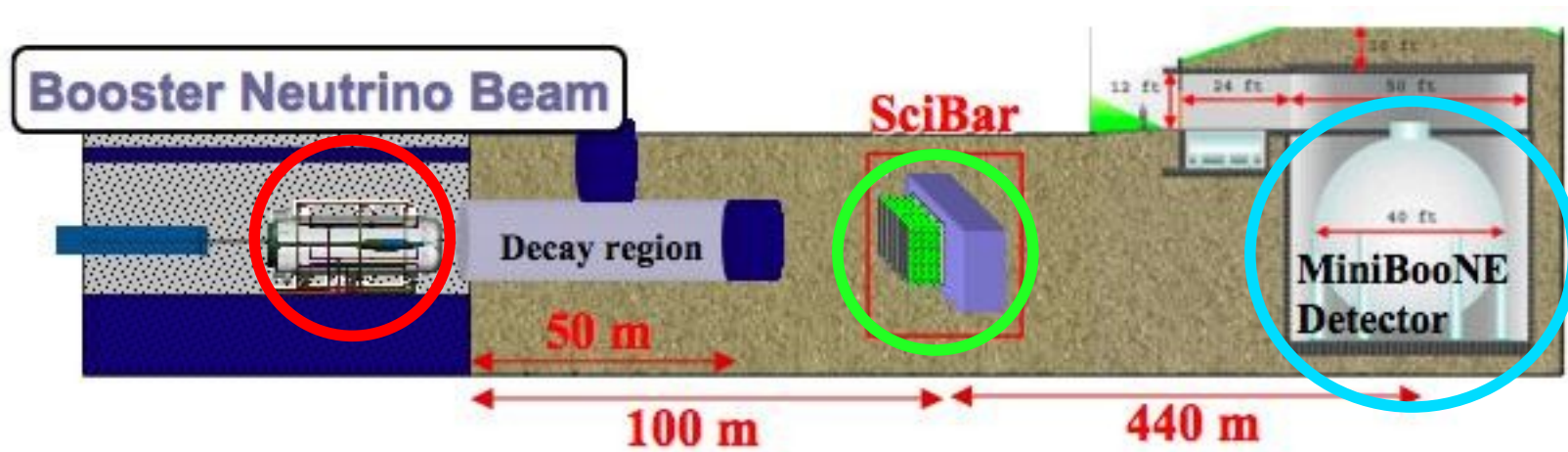

# SciBooNE

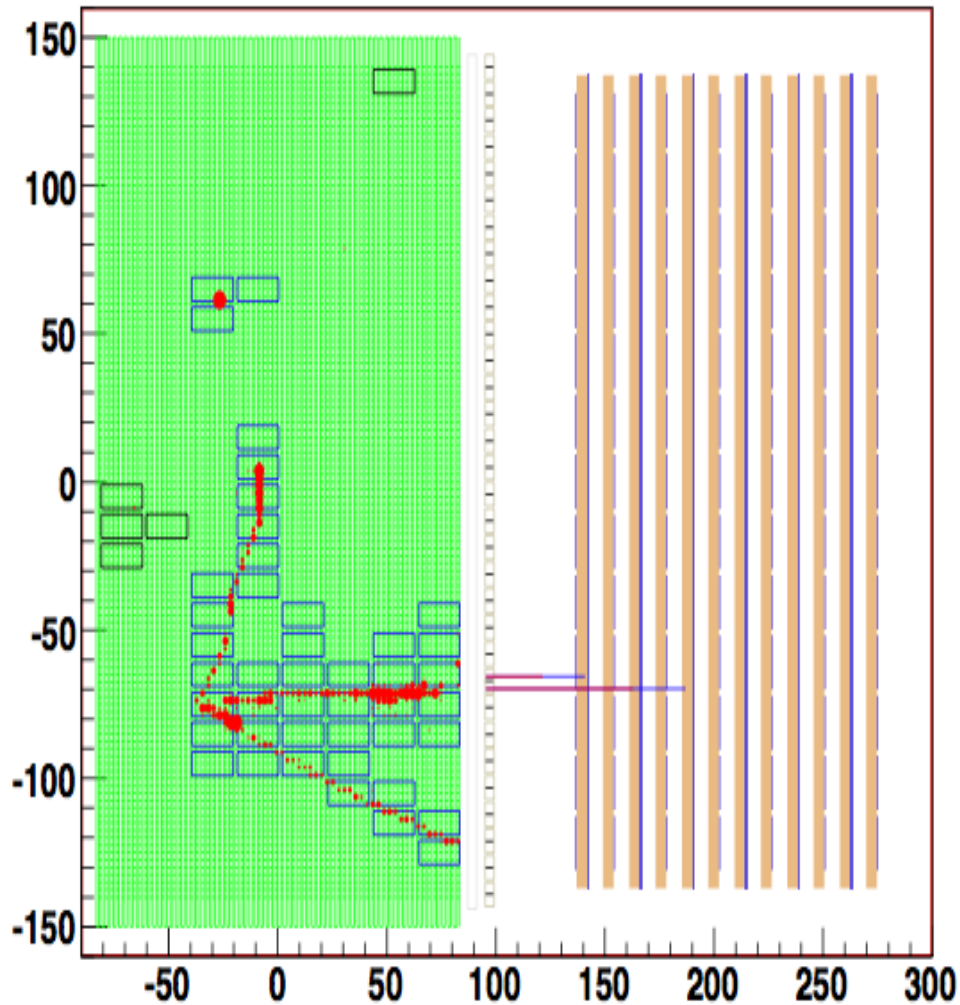

- SciBooNE already running!
- 2 years from formation of collaboration to first data!

CHANNEL	$\nu$	Anti- $\nu$
CCQE	39k	7.5k
CC $1\pi^+$	24k	2k
NC $1\pi^0$	9k	1.3k
NC Coherent	0.8k	0.3k

# MINERvA

- Active core is segmented solid scintillator
  - Tracking (including low momentum recoil protons)
  - Particle identification by energy deposition ( $dE/dx$ )
  - 3 ns (RMS) per hit timing (track direction, identify stopped  $K^\pm$ )
- Core surrounded by electromagnetic and hadronic calorimeters
  - Photon ( $\pi^0$ ) & hadron energy measurement
- Upstream region has simultaneous C, Fe, Pb, He targets to study nuclear effects
- MINOS Near Detector as muon catcher

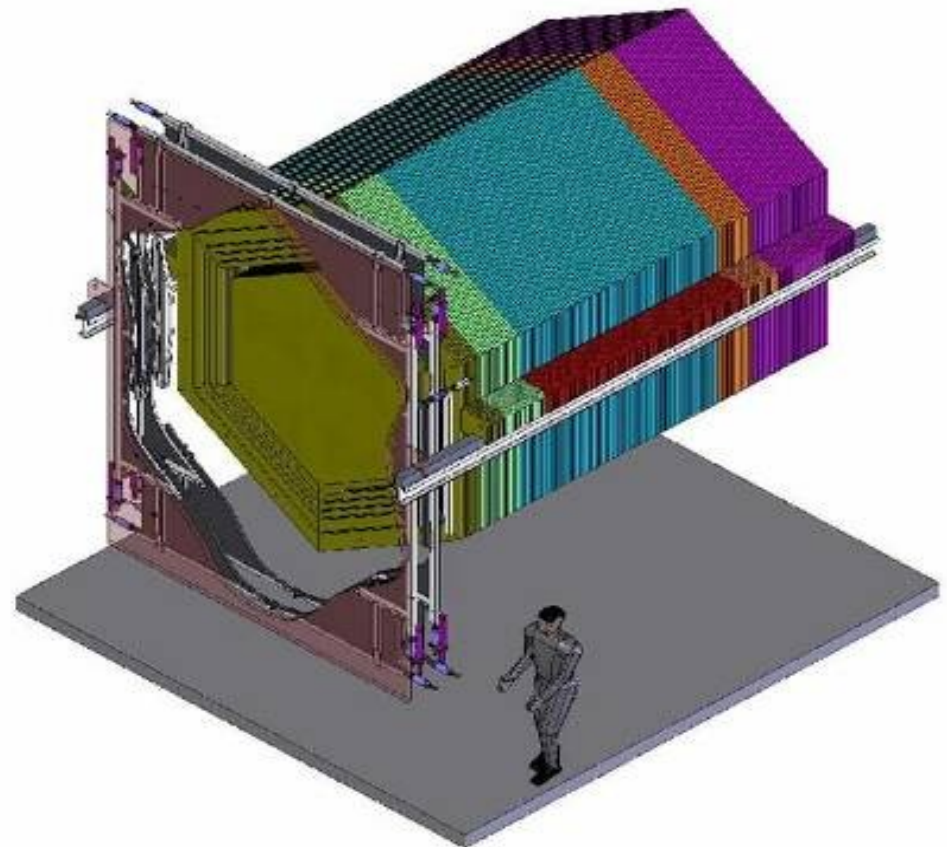

# MINERvA

Fiducial Mass : 3 ton CH, 0.6 ton C, 1 ton Fe, 1 ton Pb

## Total Event rate

Target CC  $\nu$  Rate

CH	8.6 M
C	1.4 M
Fe	2.9 M
Pb	2.9 M

## Physics Event rate in CH

Process

Rate

QE	0.8 M
1 pion	1.6 M
Transition	2.0 M
DIS	4 M

# CCQE Cross section

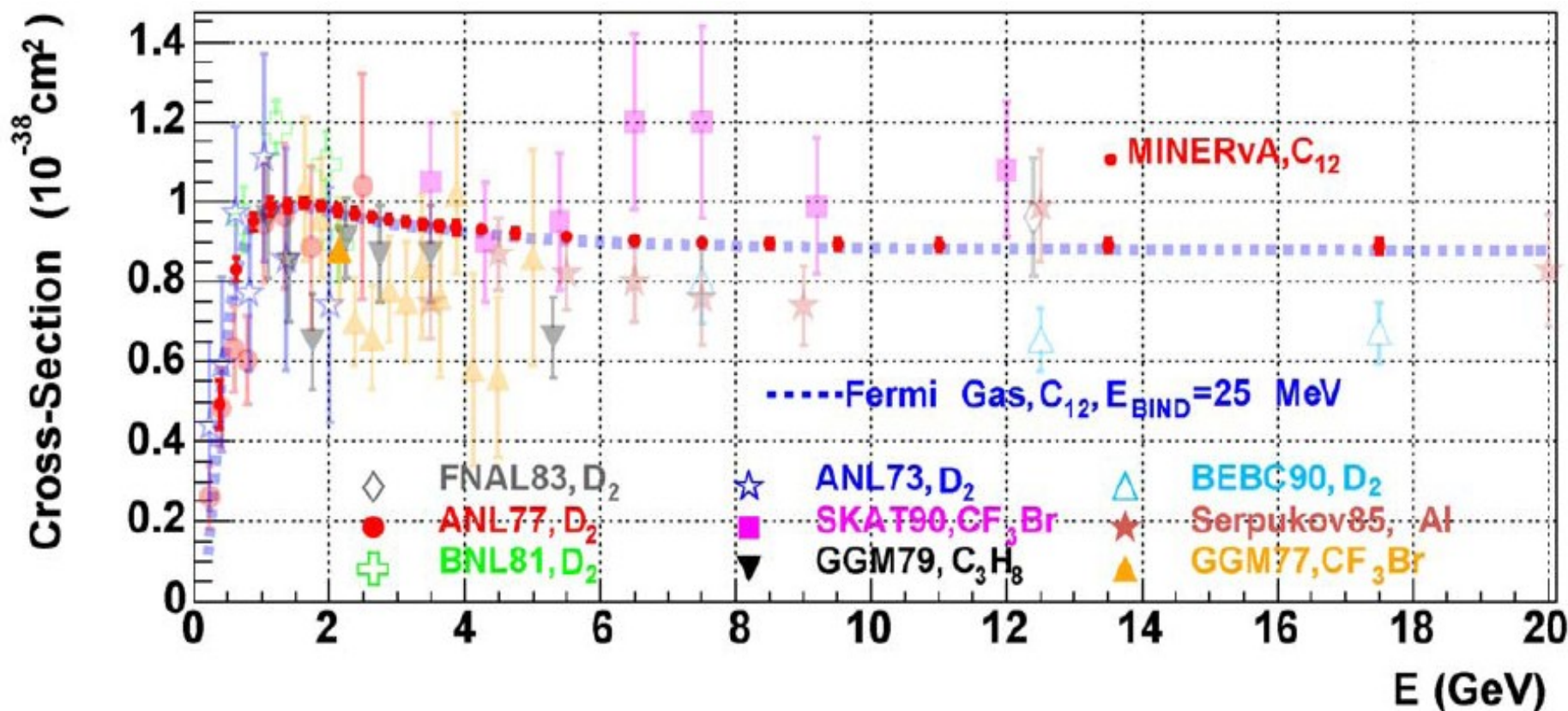

High efficiency and purity ( $\sim 77\%$  and  $\sim 74\%$  resp.)  
Nuclear Effects can be studied in nuclear targets  
Deviation from dipole form factors can be studied

# Deep Inelastic Scattering

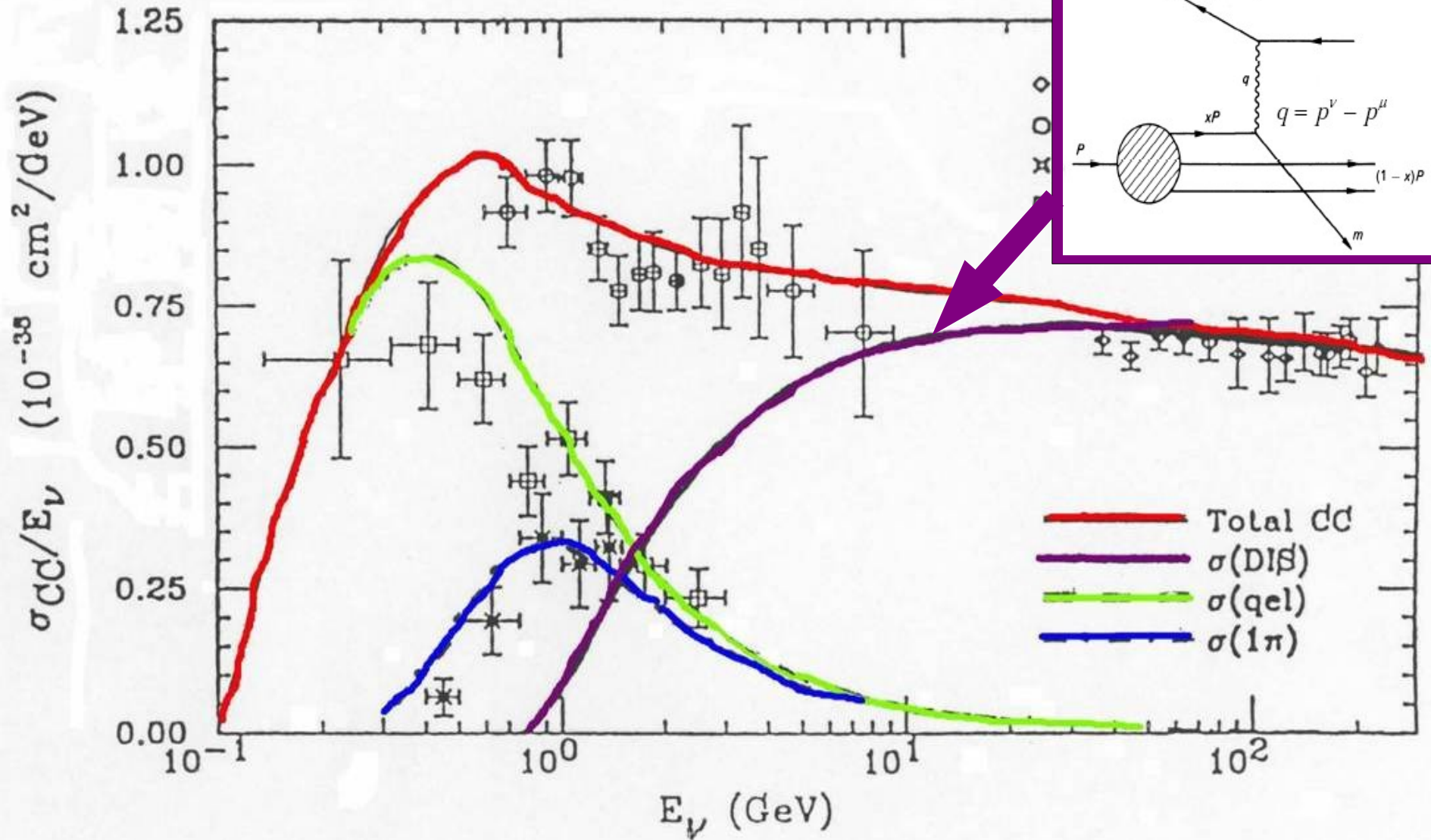

# Deep Inelastic Scattering

In DIS, the neutrino is scattered as scattering off a free parton within the nucleon

In “infinite momentum frame” all partons are moving collinear to direction of motion of nucleon and are asymptotically free

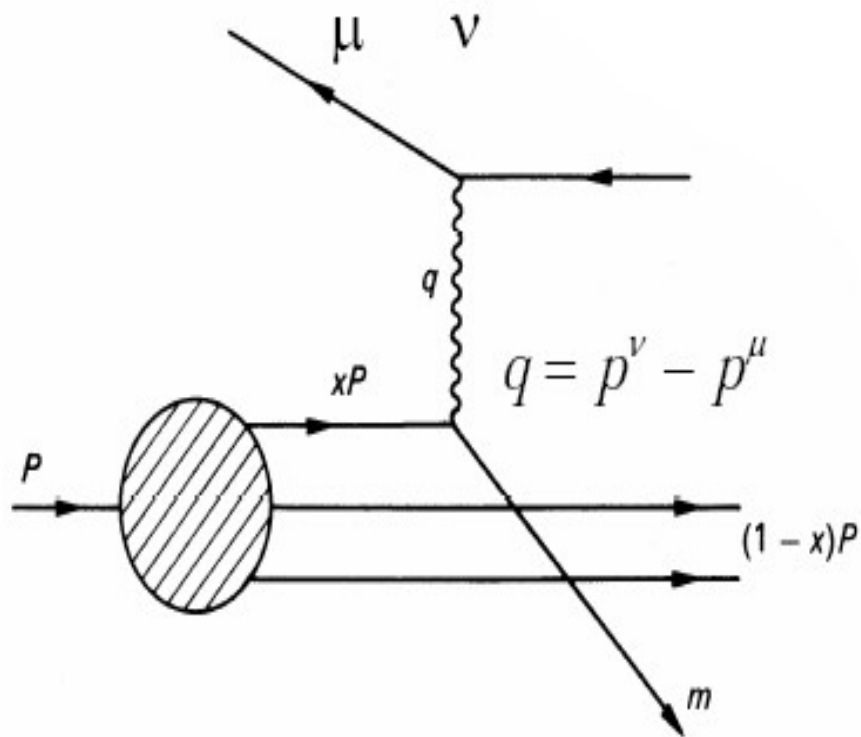

$x$  can be thought of as the fraction of nucleon momentum carried by the struck quark

$$\text{mass of FS quark} = m_q^2 = (xP + q)^2$$

$$\text{If } Q^2 \gg m_q^2, M_T^2 \Rightarrow x = Q^2 / 2P \cdot q$$

$$0 < x < 1$$

# DIS Cross section

Situation : neutrino scattering off massive point-like object

This is *almost* exactly the same as  $\nu$ - $e$  scattering

Pointlike scattering

$$\frac{d^2 \sigma^{\nu q}}{dx dy} = \frac{G_F^2 s}{\pi} q(x)$$

$$\frac{d^2 \sigma^{\nu \bar{q}}}{dx dy} = \frac{G_F^2 s}{\pi} \bar{q}(x) (1-y)^2$$

Parton distribution function

Chiral structure

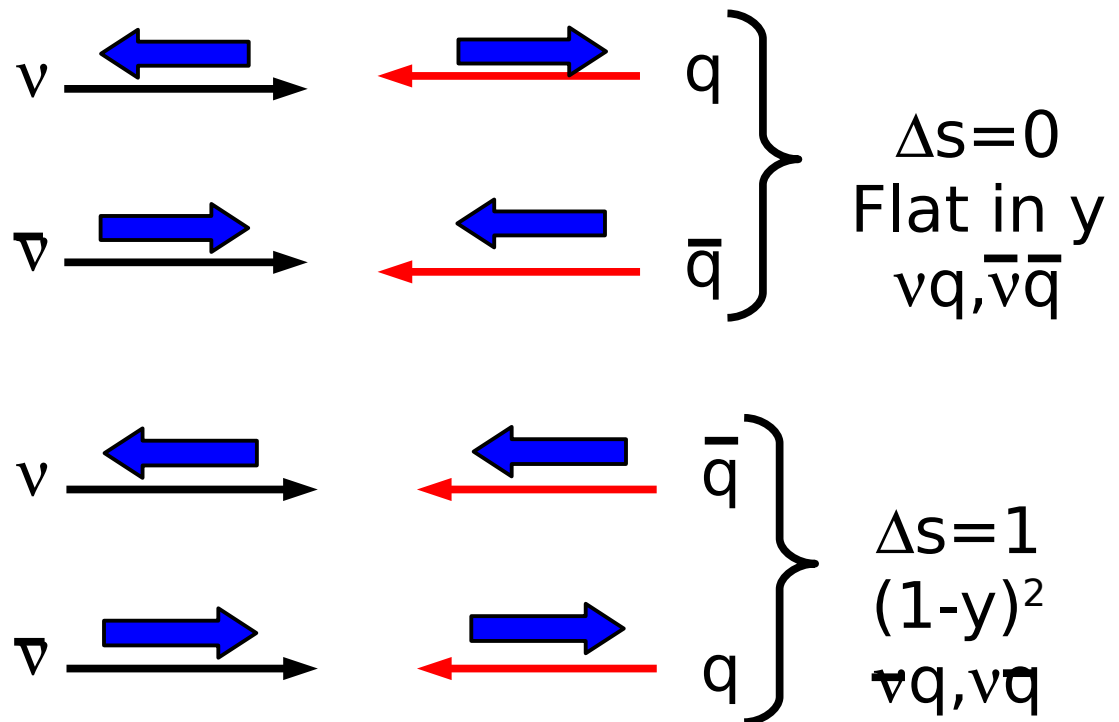

# Y-distribution in DIS

(From CDHS)

$Y=0$   
 $\nu$  and  $\bar{\nu}$   
are identical

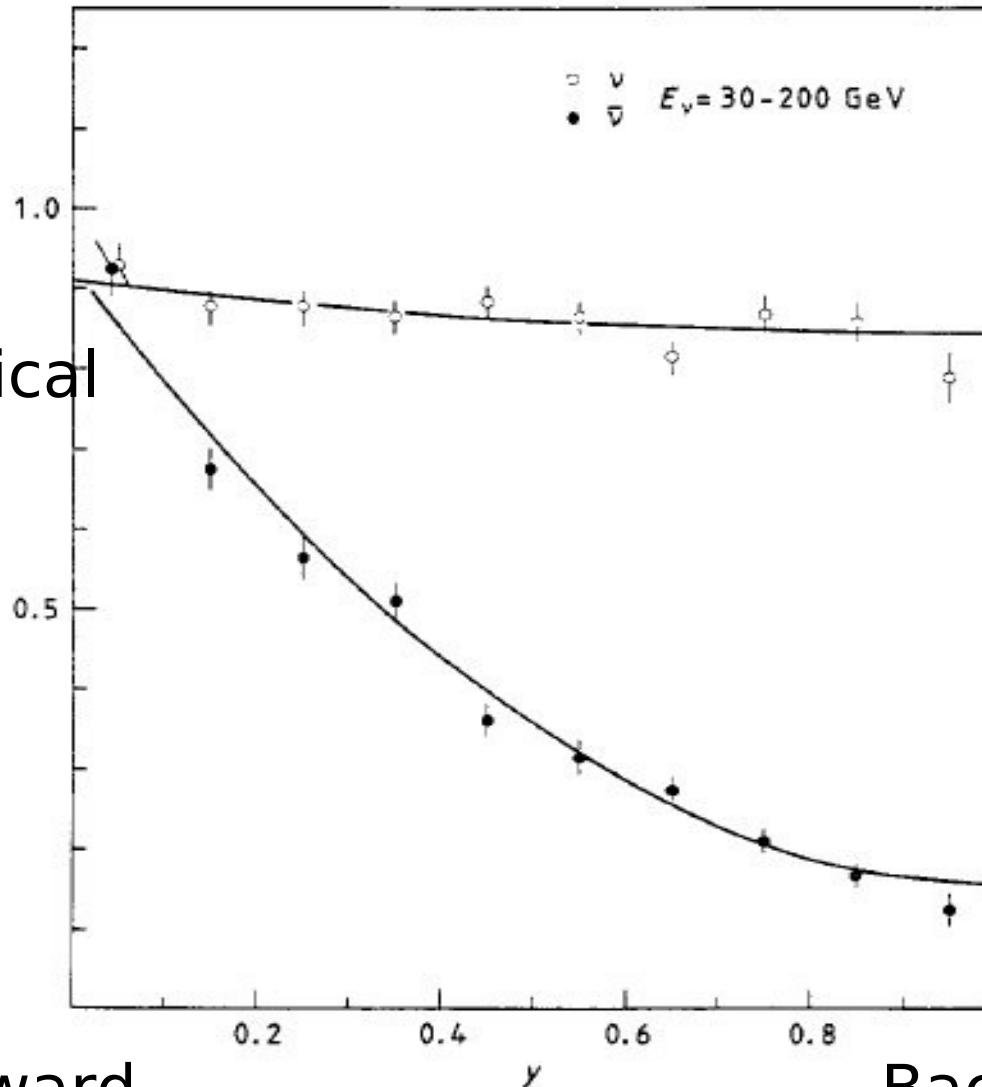

At  $y=1$ , neutrinos  
see only quarks

Antineutrinos see  
only antiquarks

Forward  
Scattering

Backward  
Scattering

# Parton Distributions

The probability of finding a quark of flavour 'q' in the nucleon with fractional momentum x is  $q(x)$ .

The number of quarks of flavour q with fractional momenta between x and x+dx is  $q(x)dx$

## Factorisation Theorem of QCD

$$A(l+h \rightarrow l'+H) = \sum_q A(l+q(x) \rightarrow l'+X) q_h(x)$$

Int. of lepton with hadron                      Int. of lepton with a quark                      P(q ∈ h)

- Parton distributions ( $q_h(x)$ =pdf) are universal
- Are not yet calculable (so we need to measure them)

# Scattering from Nucleons

Proton =  $uud + (\bar{u}\bar{u}) + (\bar{d}\bar{d}) + (\bar{s}\bar{s}) + (\bar{c}\bar{c})$

$$\frac{d^2 \sigma (CC \nu p)}{dx dy} = \frac{G_F^2 s}{\pi} [(xd(x) + xs(x)) + (\bar{u}(x) + \bar{c}(x))(1-y)^2]$$

$$\frac{d^2 \sigma (CC \bar{\nu} p)}{dx dy} = \frac{G_F^2 s}{\pi} [(xu(x) + xc(s))(1-y)^2 + (\bar{d}(x) + \bar{s}(x))]$$

To get the cross section for scattering from a neutron

Neutron =  $ddu + (\bar{u}\bar{u}) + (\bar{d}\bar{d}) + (\bar{s}\bar{s}) + (\bar{c}\bar{c})$

Isospin Symmetry

$$u_n(x) = d_p(x) = d(x)$$

$$d_n(x) = u_p(x) = u(x)$$

$$s_n(x) = s_p(x) = s(x)$$

$$c_n(x) = c_p(x) = c(x)$$

$$\frac{d^2 \sigma (CC \nu n)}{dx dy} = \frac{G_F^2 s}{\pi} [(xu(x) + xs(x)) + (\bar{d}(x) + \bar{c}(x))(1-y)^2]$$

$$\frac{d^2 \sigma (CC \bar{\nu} n)}{dx dy} = \frac{G_F^2 s}{\pi} [(xd(x) + xc(s))(1-y)^2 + (\bar{u}(x) + \bar{s}(x))]$$

# Or...we can use structure functions

A model independent picture can be formed using nucleon structure functions

$$\frac{d^2 \sigma^{\nu, \bar{\nu}}}{dx dy} = \frac{G_F^2 s}{\pi} \left[ y^2 2x F_1(x, Q^2) + 2 \left( 1 - y - \frac{Mxy}{2E} \right) F_2(x, Q^2) \pm 2y \left( 1 - \frac{y}{2} \right) x F_3(x, Q^2) \right]$$

$F_i$  are related to the helicity-structure of the q-W interaction  
For massless spin-1/2 partons we can make a simplification

**Callen-Gross Relation** :  $2xF_1 = F_2$

$$\frac{d^2 \sigma^{\nu, \bar{\nu}}}{dx dy} = \frac{G_F^2 s}{\pi} \left[ \left( (1-y)^2 + \left( 1 - \frac{Mxy}{2E} \right) \right) F_2(x, Q^2) \pm 2y \left( 1 - \frac{y}{2} \right) x F_3(x, Q^2) \right]$$

Structure functions must (again) be measured

# Relationship to $q(x)$

One can relate  $F_i$  to the pdf's by matching the y-dependence  
Assuming the Callen-Gross relationship, massless partons and  
targets.....



$$F_2^{\nu p, CC} = x [d_p(x) + \bar{u}_p(x) + s_p(x) + \bar{c}_p(x)]$$
$$xF_3^{\nu p, CC} = x [d_p(x) - \bar{u}_p(x) + s_p(x) - \bar{c}_p(x)]$$

For an *isoscalar* target (equal numbers of protons and neutrons)

$$q = u + d + s + c ; \bar{q} = \bar{u} + \bar{d} + \bar{s} + \bar{c}$$

$$F_2^{\nu N, CC} = x [q(x) + \bar{q}(x)]$$

$$xF_3^{\nu N, CC} = x [q(x) - \bar{q}(x)]$$

# Cross section

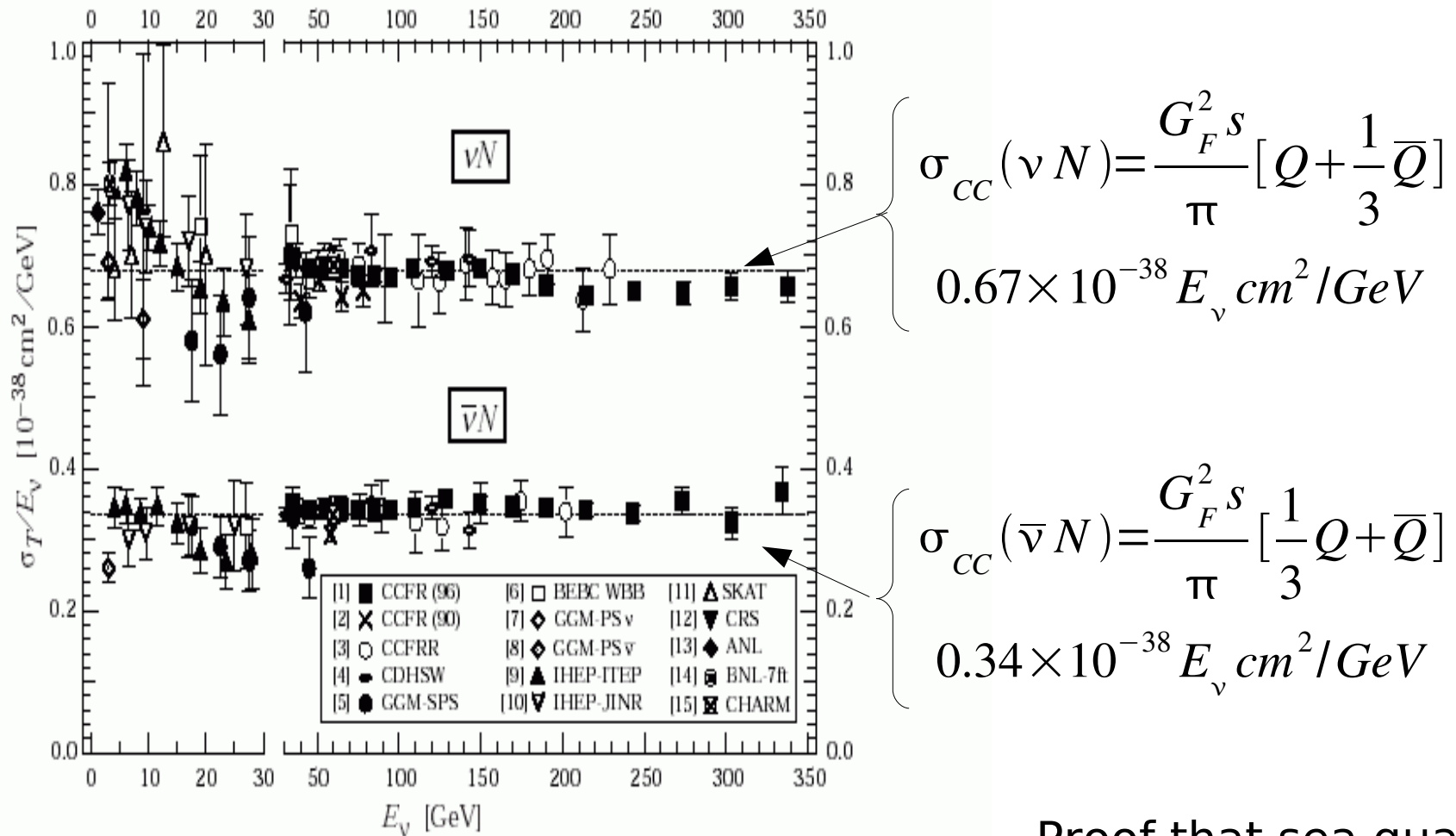

Proof that sea quarks exist!

Figure 39.10:  $\sigma_T/E_\nu$ , for the muon neutrino and anti-neutrino charged-current total cross section as a function of neutrino energy. The error bars include both statistical and systematic errors. The straight lines are the averaged values over all energies as measured by the experiments in Refs. [1–4]:  $= 0.677 \pm 0.014$  ( $0.334 \pm 0.008$ )  $\times 10^{-38} \text{ cm}^2/\text{GeV}$ . Note the change in the energy scale at 30 GeV. (Courtesy W. Seligman and M.H. Shaevitz, Columbia University, 2001.)

# Neutral Currents

As with  $\nu$ -e scattering, the NC interaction contains both V-A and V+A contributions.

All quark flavours participate in the interaction  
u and d quarks contribute different coupling constants  
for Left and Right-handed states.

So instead of this

$$F_2^{\nu p, CC} = x [d_p(x) + \bar{u}_p(x) + s_p(x) + \bar{c}_p(x)]$$
$$xF_3^{\nu p, CC} = x [d_p(x) - \bar{u}_p(x) + s_p(x) - \bar{c}_p(x)]$$

# Neutral Currents

As with  $\nu$ -e scattering, the NC interaction contains both V-A and V+A contributions.

All quark flavours participate in the interaction  
u and d quarks contribute different coupling constants  
for Left and Right-handed states.

You get this....

$$F_2^{\nu p, NC} = x[(g_{L,u}^2 + g_{R,u}^2)(u(x) + \bar{u}(x) + c(x) + \bar{c}(x))] \\ + x[(g_{L,d}^2 + g_{R,d}^2)(d(x) + \bar{d}(x) + s(x) + \bar{s}(x))] \\ xF_3^{\nu p, NC} = x[(g_{L,u}^2 - g_{R,u}^2)(u(x) - \bar{u}(x) + c(x) - \bar{c}(x))] \\ + x[(g_{L,d}^2 - g_{R,d}^2)(d(x) - \bar{d}(x) + s(x) - \bar{s}(x))]$$

$$g_{L,u} = \frac{1}{2} \left( 1 - \frac{4}{3} \sin^2 \theta_W \right); g_{R,u} = -\frac{2}{3} \sin^2 \theta_W$$

$$g_{L,d} = \frac{1}{2} \left( -1 + \frac{2}{3} \sin^2 \theta_W \right); g_{R,d} = \frac{1}{3} \sin^2 \theta_W$$

# So...what?

Define : 
$$R^\nu = \frac{\sigma_{NC}(\nu N)}{\sigma_{CC}(\nu N)}; R^{\bar{\nu}} = \frac{\sigma_{NC}(\bar{\nu} N)}{\sigma_{CC}(\bar{\nu} N)}; r = \frac{\sigma_{CC}(\nu N)}{\sigma_{CC}(\bar{\nu} N)}$$

Then 
$$R^\nu = \frac{1}{2} - \sin^2 \theta_w + (1+r) \frac{5}{9} \sin^4 \theta_w$$

$$R^{\bar{\nu}} = \frac{1}{2} - \sin^2 \theta_w + \left(1 + \frac{1}{r}\right) \frac{5}{9} \sin^4 \theta_w$$

Llewellyn-Smith relationships

$$\sin^2 \theta_w = 0.223 \pm 0.003 \pm 0.005$$

$$0.2227 \pm 0.00037 \text{ (world average)}$$

From CHARM, CDHS, CCFR

# Status of $\sin^2\theta_w$



NuTeV was the last experiment to make a precision measurement of  $\sin\theta_w$  in neutrino interactions

# NUTEV

Iron Sampling calorimeter : CDHS,CHARM,CCFR,NUTEV,MINOS

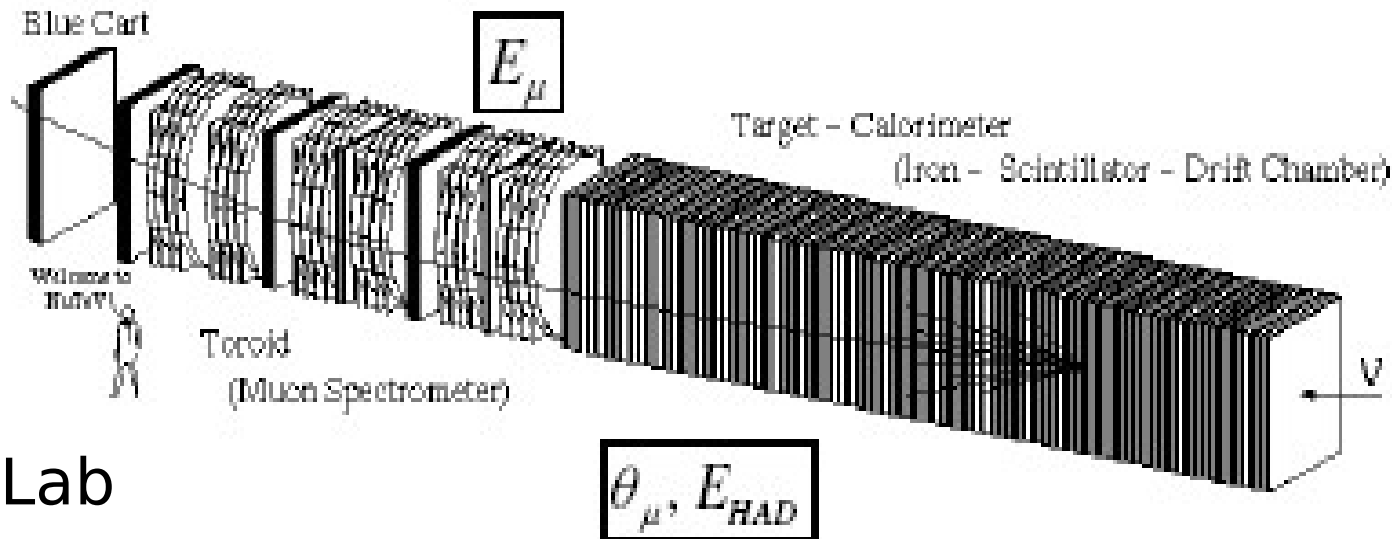

FermiLab

- Typically used for high energy (> a few GeV) beams
- Iron plates (target) interspersed by scintillator planes
- Used unique sign selected beam - NuTeV had pure neutrino and antineutrino data samples

# MINOTAU/EIT

$$\sin^2 \theta_W^{(on-shell)} = 0.2277 \pm \pm 0.0013(stat.) \pm 0.0009(syst.)$$

$$= 0.2277 \pm 0.0016$$

(Previous neutrino measurements gave  $0.2277 \pm 0.0036$ )

- Standard model fit (LEPEWWG):  $0.2227 \pm 0.00037$

A  $3\sigma$  discrepancy .....

$$R_{\text{exp}}^\nu = 0.3916 \pm 0.0013$$

(SM : 0.3950)  $\Leftarrow 3\sigma$  difference

$$\bar{R}_{\text{exp}}^\nu = 0.4050 \pm 0.0027$$

(SM : 0.4066)  $\Leftarrow$  Good agreement

68%,90%,95%,99% C.L. Contours, Grid of SM  $\pm 1\sigma$  mtop, mHiggs

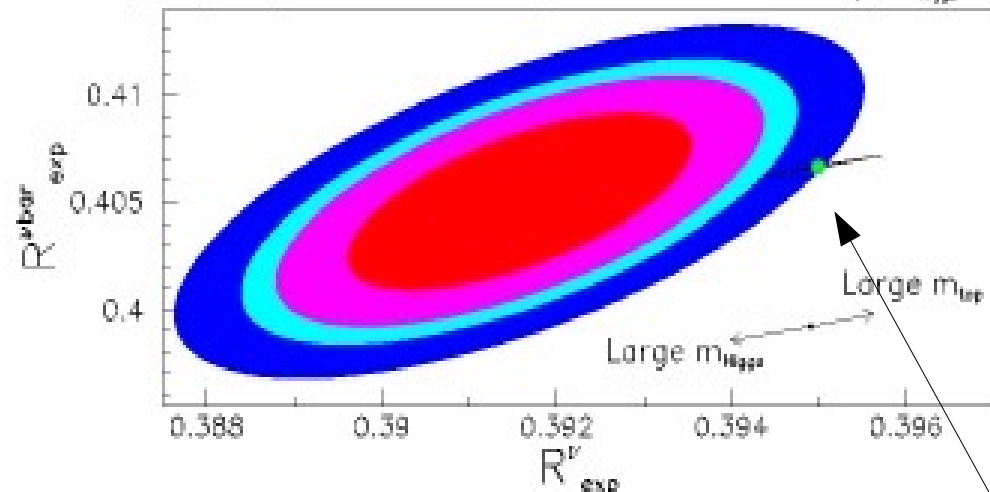

Standard Model measurement

$$R^\nu = \frac{\sigma_{NC}(\nu N)}{\sigma_{CC}(\nu N)}; R^{\bar{\nu}} = \frac{\sigma_{NC}(\bar{\nu} N)}{\sigma_{CC}(\bar{\nu} N)}$$

# Comparison

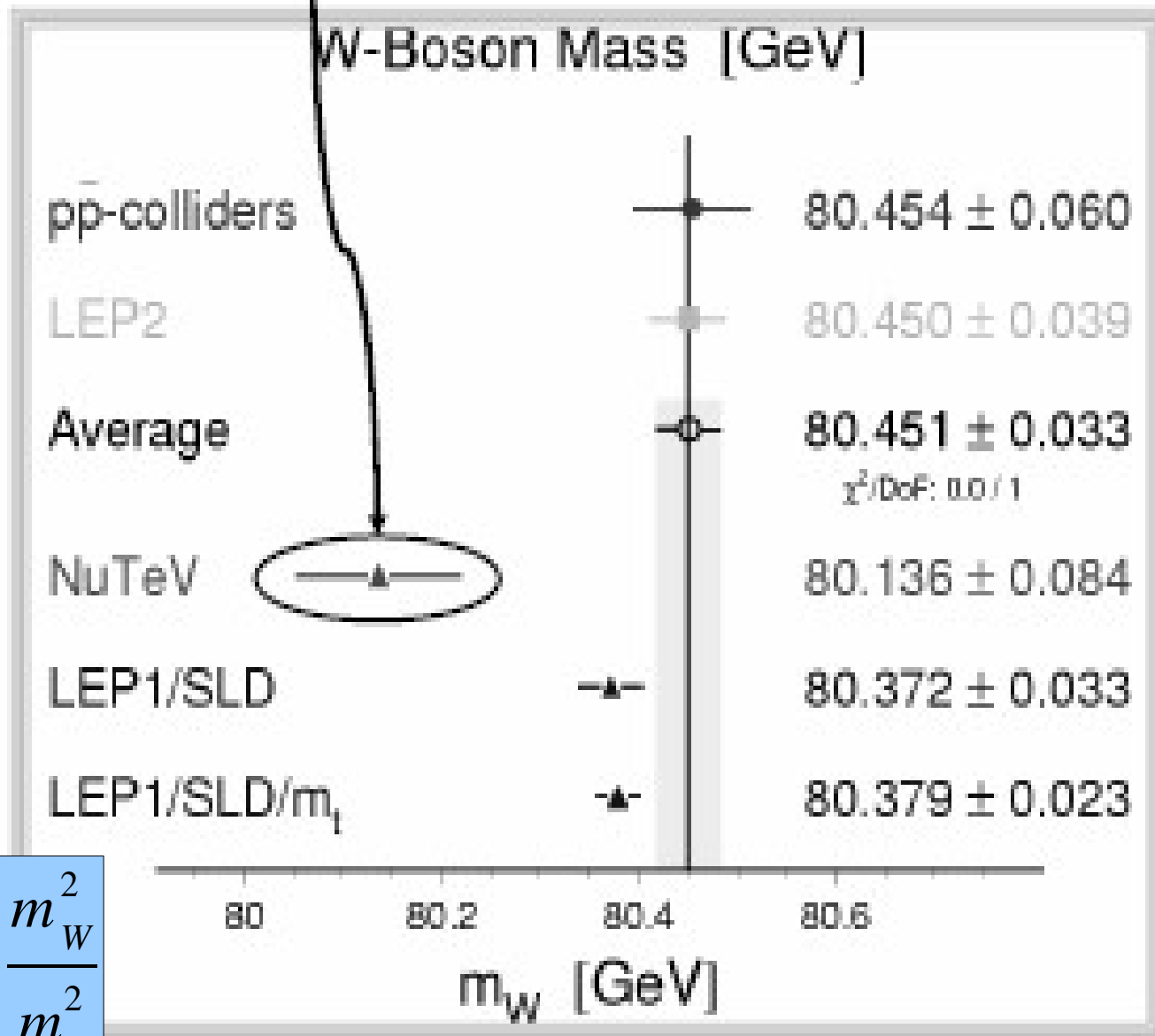

$$\sin^2 \theta_w = 1 - \frac{m_W^2}{m_Z^2}$$

# Possible

- ## interpretations
- *New Beyond-Standard-Model physics?*
    - Difficult to find something which does this just for  $\nu$
  - *Purely experimental*
    - Multiple checks. Not obvious if it is.
  - *Mundane explanations*
    - Charm mass effects
    - Radiative effects
    - Isospin symmetry violation :  $u_p(x) \neq d_n(x)$
    - Strange/anti-Strange sea asymmetry :  $s(x) \neq \bar{s}(x)$   
(intrinsic strangeness?)
    - Different nuclear effects for NC over CC (Z over W)



# Fermi Theory (1926-34)

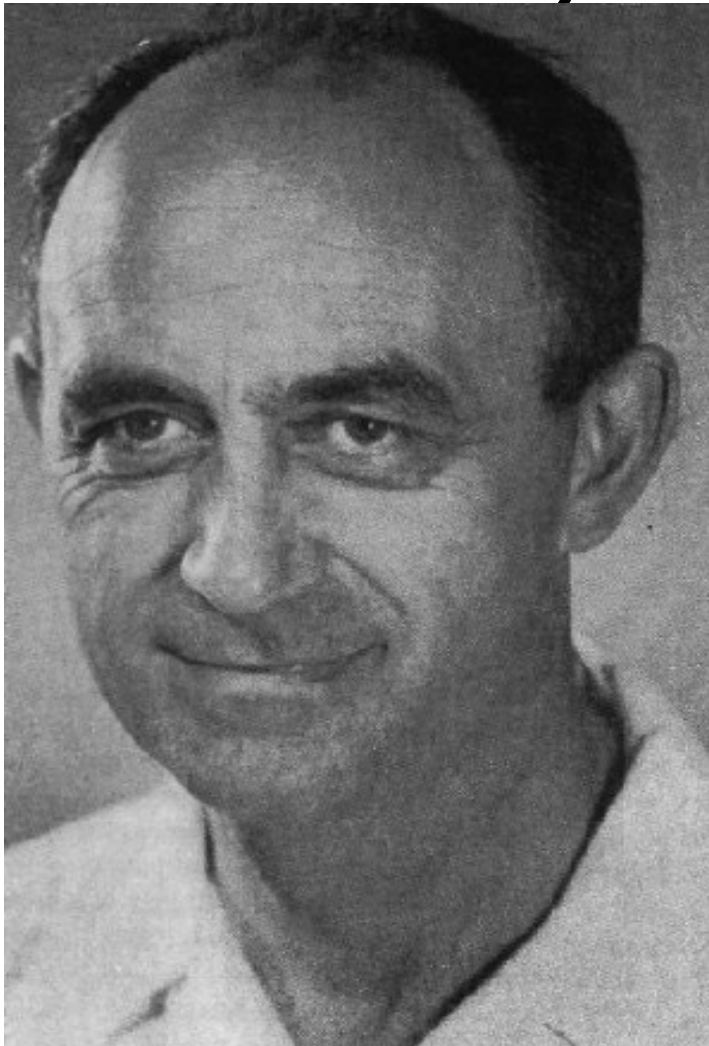

Initial paper rejected by Nature because:

*“it contains speculations to remote from reality to be of interest to the reader”*

# Neutral Currents

The electroweak theory of Glashow, Weinberg and Salam predicted two types of weak interactions rather than just one, as predicted by V-A Fermi theory

Charged current :  $\nu_l + X \rightarrow l + X'$   $(l^-, \nu)(l^+, \bar{\nu})$

Neutral current :  $\nu_l + X \rightarrow \nu_l + X'$  Flavour blind

Interpreted as the exchange of two IVBs :  $W^\pm, Z^0$

Discovery by Gargamelle bubble chamber in 1970 very controversial at the time. It was to take another year before the claims were verified



$$\bar{\nu}_e + e^- \rightarrow \bar{\nu}_e + e^-$$

# Oh the pain

*“I have done something very bad today by proposing a particle that cannot be detected. It is something that no theorist should ever do.”*

*Pauli, 1930*

# Project Poltergeist - 1051

Build a deep hole  
and evacuate it

Suspend a  
detector above  
the pit

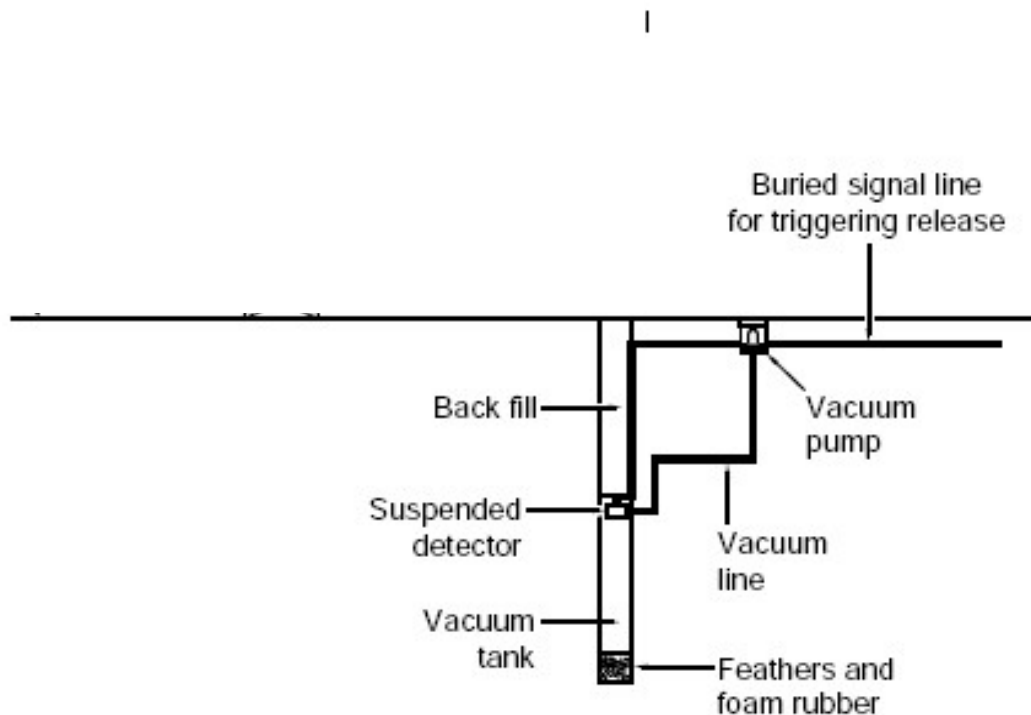

# Spin & helicity

Spin: Intrinsic angular momentum

$$\Sigma_i = \sigma^{jk} = \frac{i}{2} \epsilon_{ijk} \gamma^j \gamma^k = \begin{pmatrix} \sigma_i & 0 \\ 0 & \sigma_i \end{pmatrix}$$

Helicity: projects spin along the momentum

$$\Lambda = \vec{\Sigma} \cdot \frac{\vec{p}}{|\vec{p}|}$$

Projection operators project the components of positive and negative helicity out of an arbitrary spinor.

$$P_{\pm} \psi = \frac{1 \pm \Lambda}{2} \psi$$

# Reminder

$$(i\gamma^\mu \frac{\partial}{\partial x^\mu} - m)\psi(x) = 0 \quad \text{Dirac equation}$$

$$\psi(x) = \begin{bmatrix} \psi_1 \\ \psi_2 \\ \psi_3 \\ \psi_4 \end{bmatrix} \quad \gamma^0 = \begin{pmatrix} I & 0 \\ 0 & -I \end{pmatrix}, \quad \gamma^i = \begin{pmatrix} 0 & \sigma_i \\ \sigma_i & 0 \end{pmatrix}$$

$$\sigma_1 = \begin{pmatrix} 0 & 1 \\ 1 & 0 \end{pmatrix}, \quad \sigma_2 = \begin{pmatrix} 0 & -i \\ i & 0 \end{pmatrix}, \quad \sigma_3 = \begin{pmatrix} 1 & 0 \\ 0 & -1 \end{pmatrix}$$

$$\gamma_5 = i\gamma_0\gamma_1\gamma_2\gamma_3 \quad ; \quad \gamma_5^{adj} = \gamma_5 \quad : \quad (\gamma_5)^2 = 1 \quad : \quad \gamma_5\gamma_\mu = -\gamma_\mu\gamma_5$$

# The First Neutrino

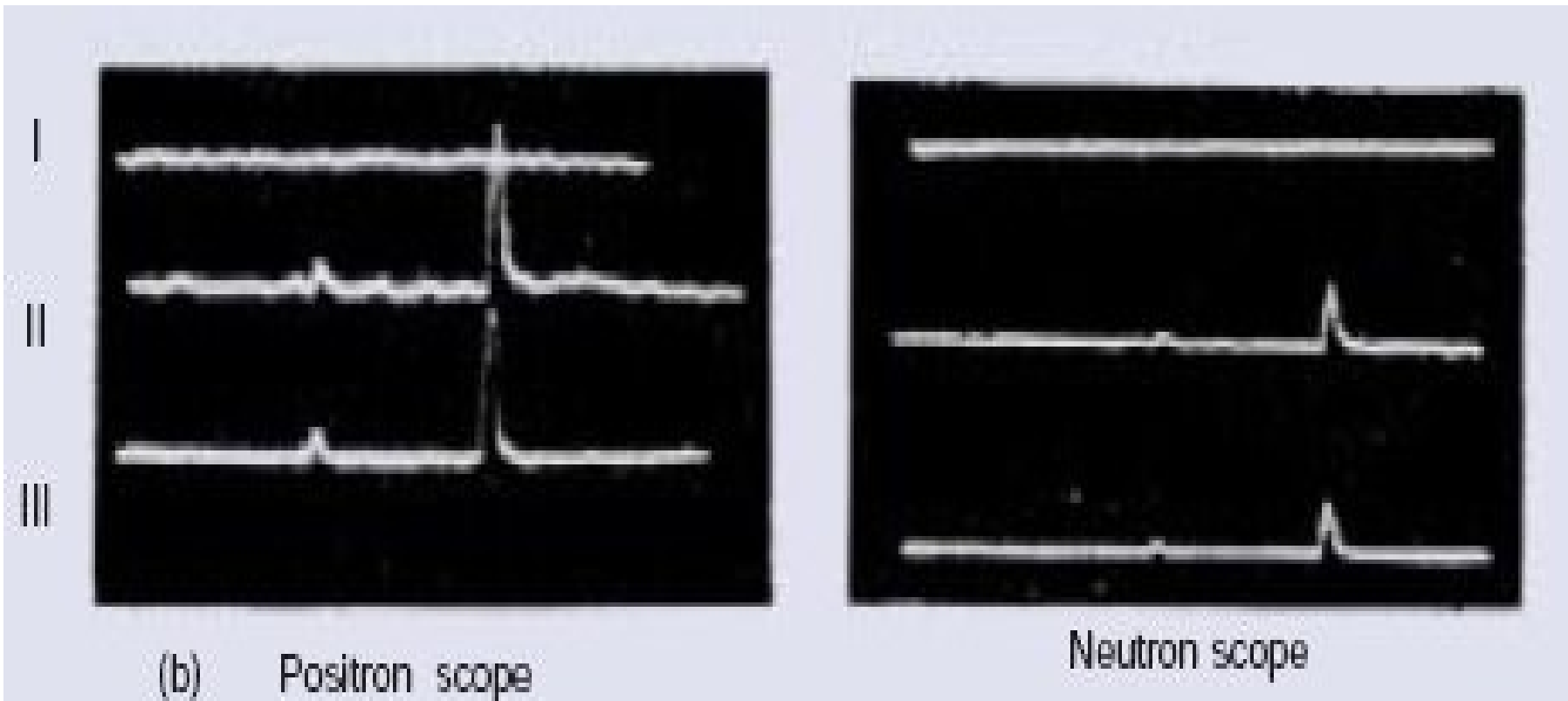

# The second neutrino

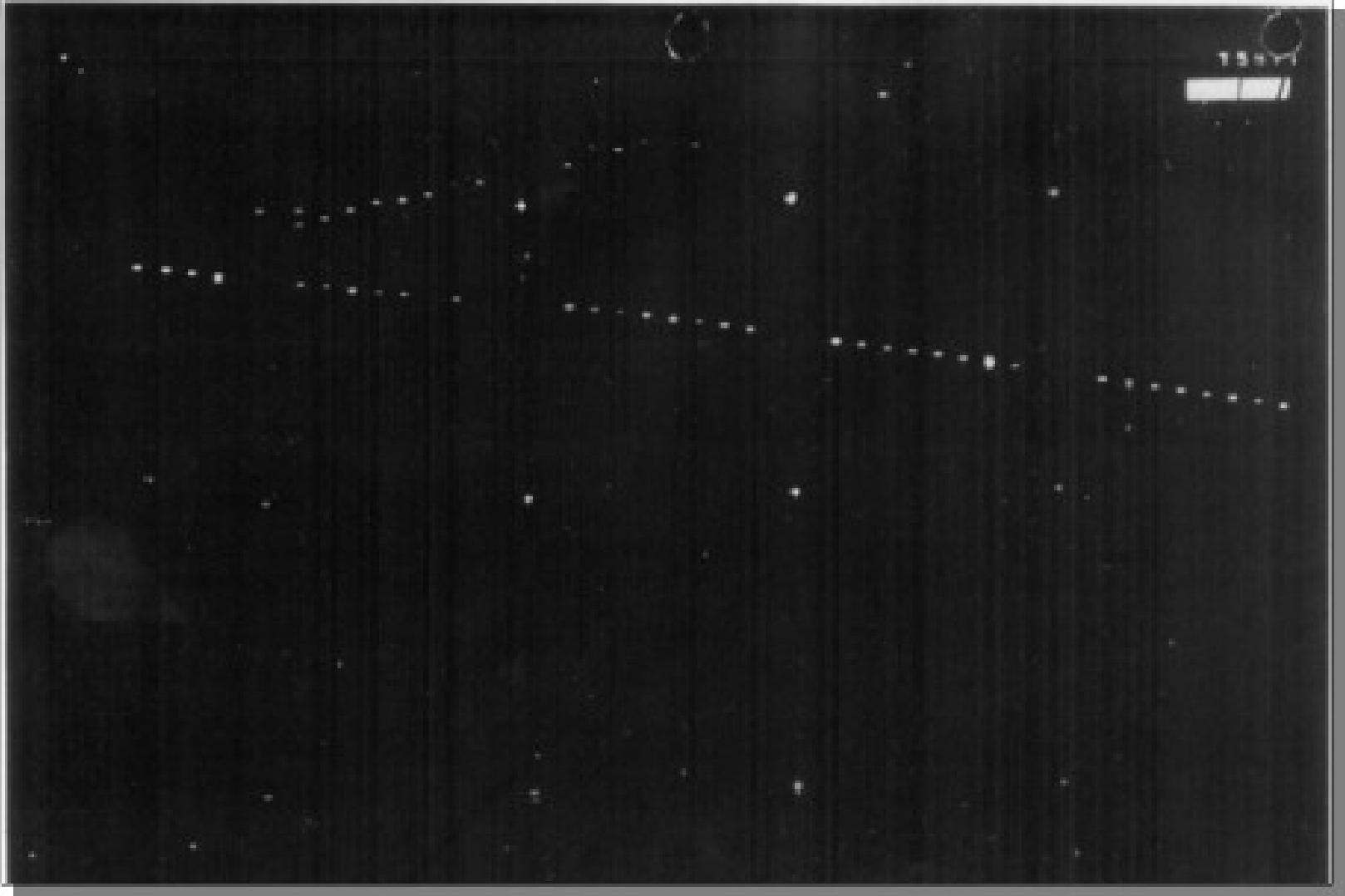

# First $\nu_\tau$

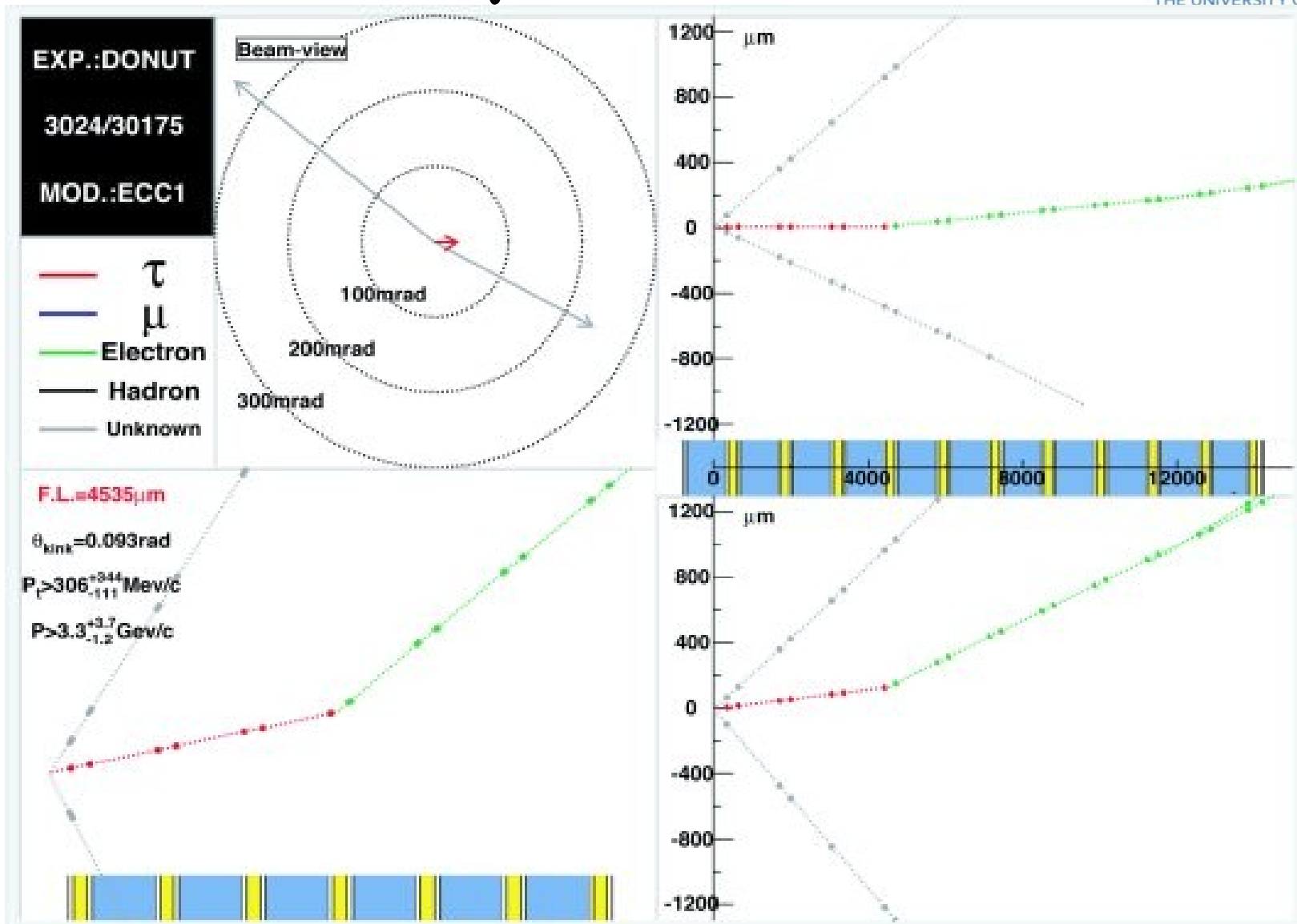

# The Tau Neutrino

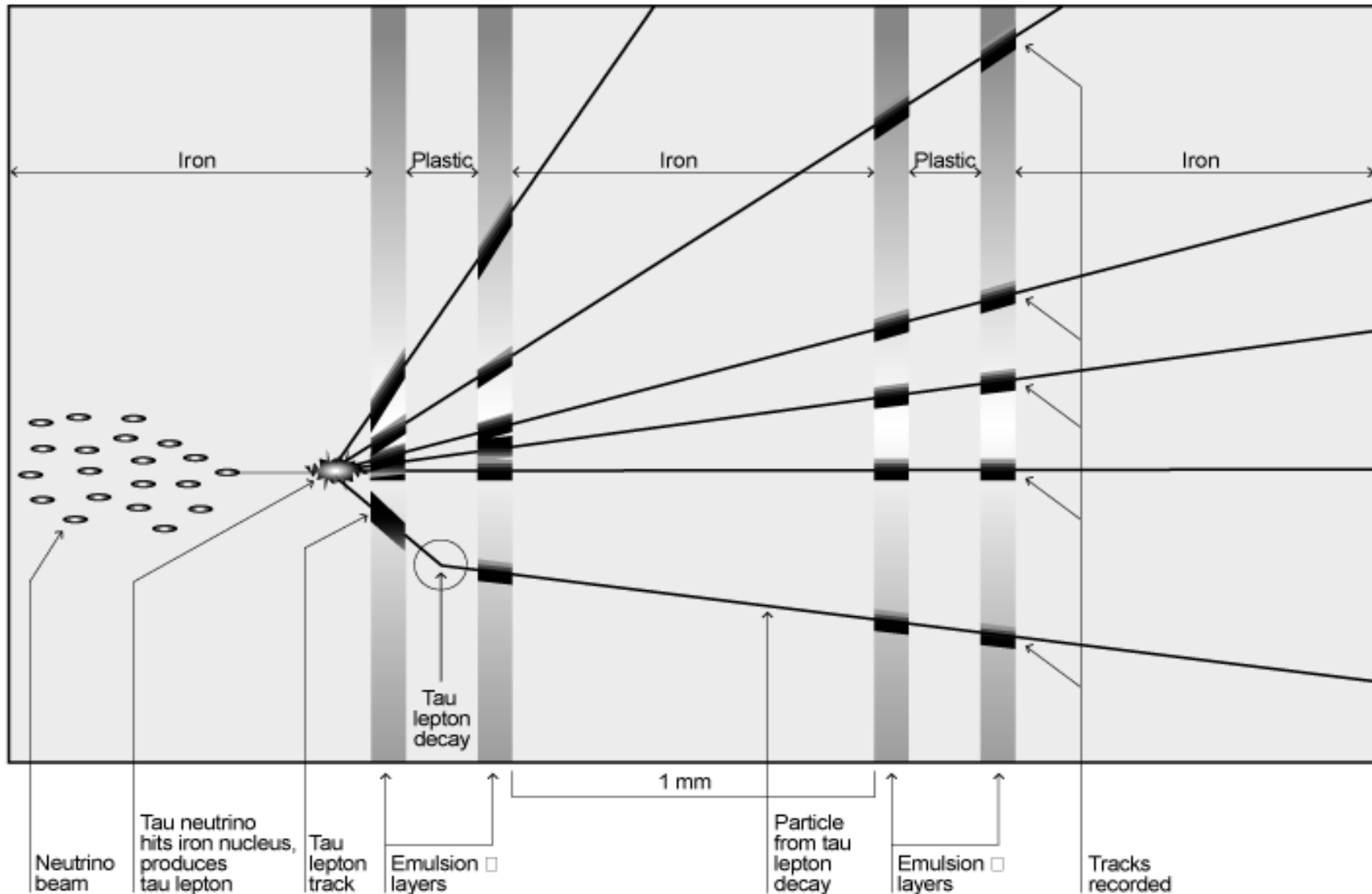

Of one million million tau neutrinos crossing the DONUT detector, scientists expect about one to interact with an iron nucleus.

# dE/dx and Range

$$-\frac{dE}{dx} = K z^2 \frac{Z}{A} \frac{1}{\beta^2} \left[ \frac{1}{2} \ln \frac{2m_e c^2 \beta^2 \gamma^2 T_{max}}{I^2} - \beta^2 - \frac{\delta(\beta\gamma)}{2} \right]$$

Bethe-Bloch

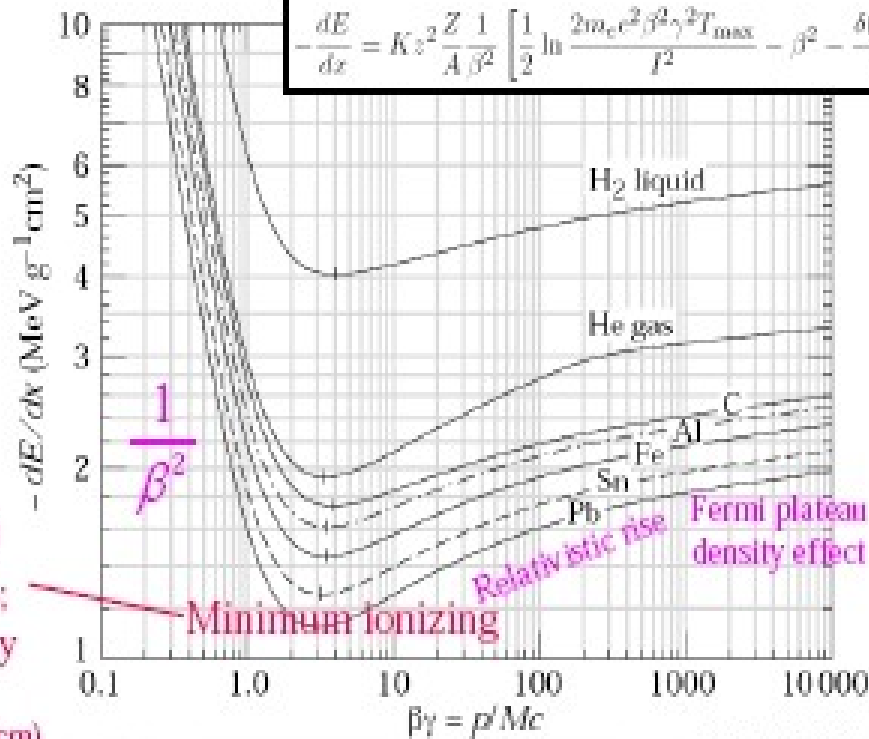

~1.5 MeV g<sup>-1</sup> cm<sup>2</sup>  
for most materials;  
multiply by density

(but water ~ 2 MeV/cm)

ALEPH

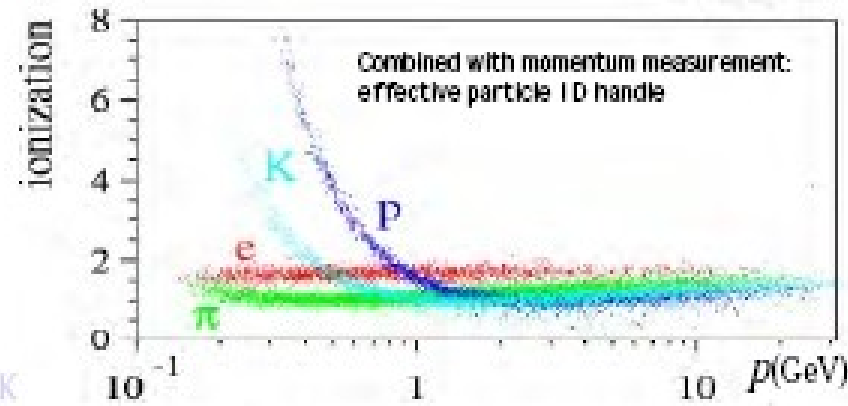

# Magnetic Tracking

$$p_t = 0.3 B [T] r [m]$$

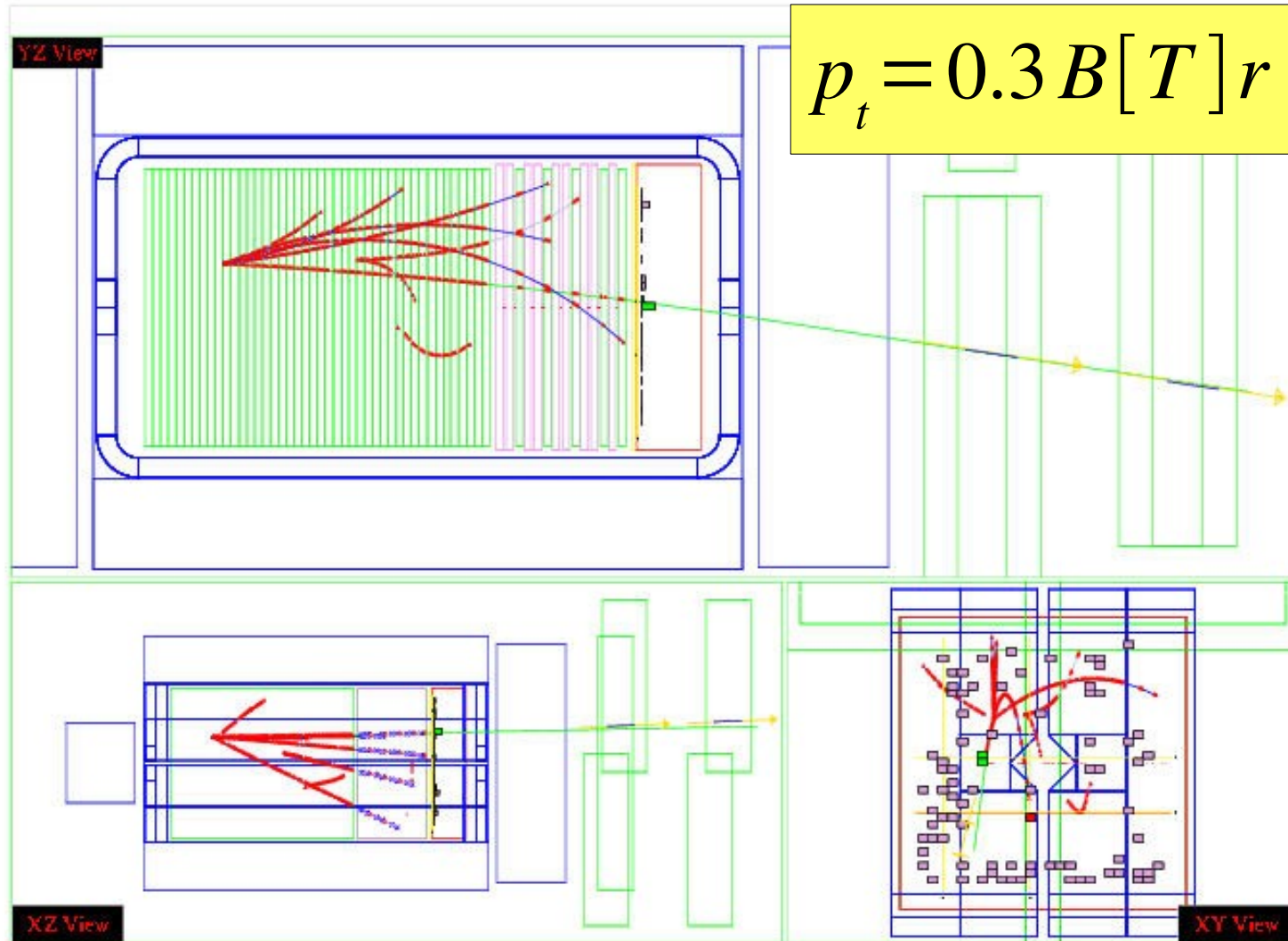

# Muons vs Photons

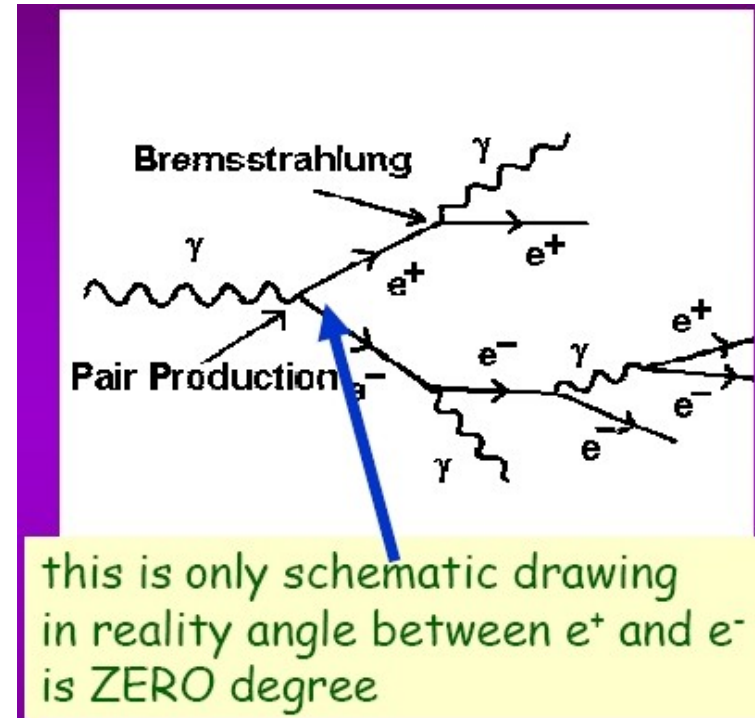
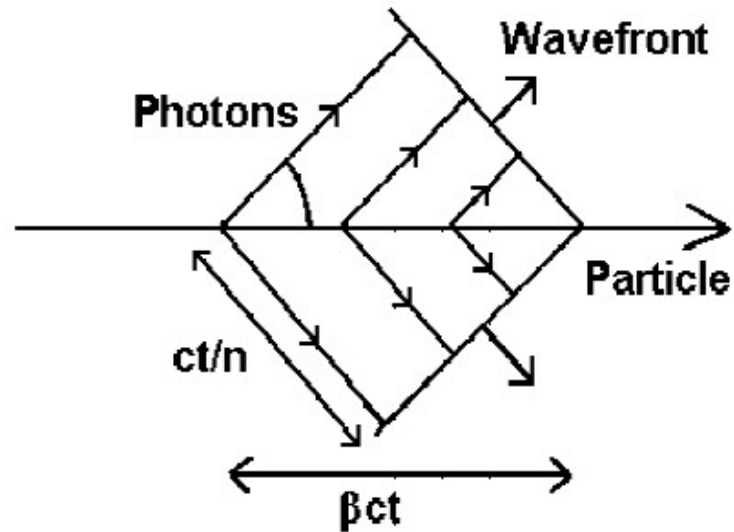

The secondary photon interactions smear out the edge of Cerenkov cone and provide particle identification as well.

# But where is it?

Still no neutrino observed experimentally? Why?  
Bethe-Peierls (1934) provided some of the answer.

Fermi theory predicted  
cross section for  $\nu p$

$$\sigma \sim 10^{-44} \text{ cm}^2 \text{ for } 2 \text{ MeV } \nu$$

$$\lambda_{lead} \sim \frac{1}{N_A \rho \sigma} = \frac{1}{6.10^{23} (\text{nuc/g}) \times 7.9 (\text{g/cm}^2) \times 10^{-44} (\text{cm}^2)}$$

$$\lambda_{lead} \approx 22 \text{ light years}$$

Need a *really* intense source of neutrinos AND  
very massive detector to detect neutrinos.

# Standard Solar Model

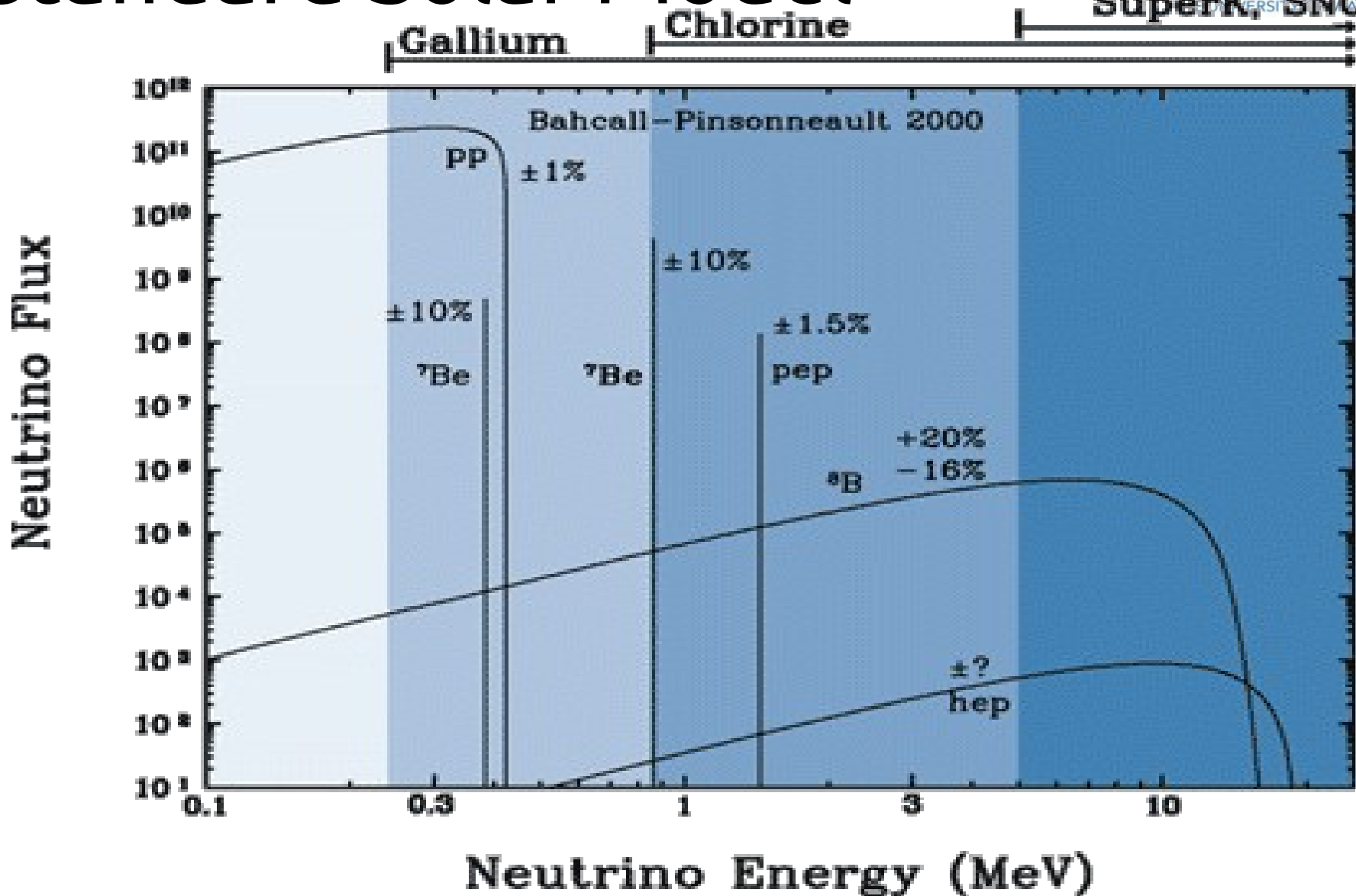

# Photomultiplier Tubes

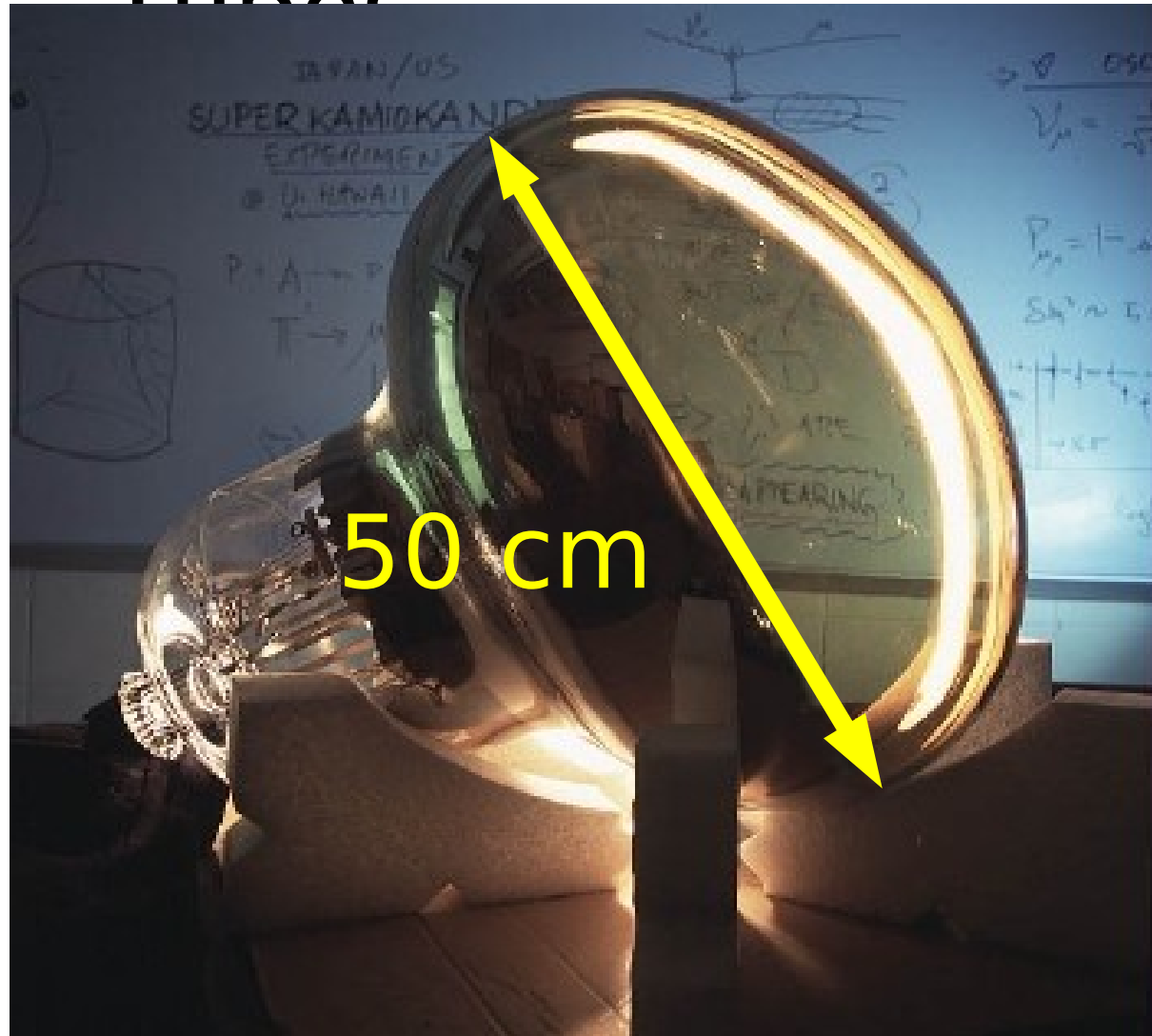

# SNO A twist

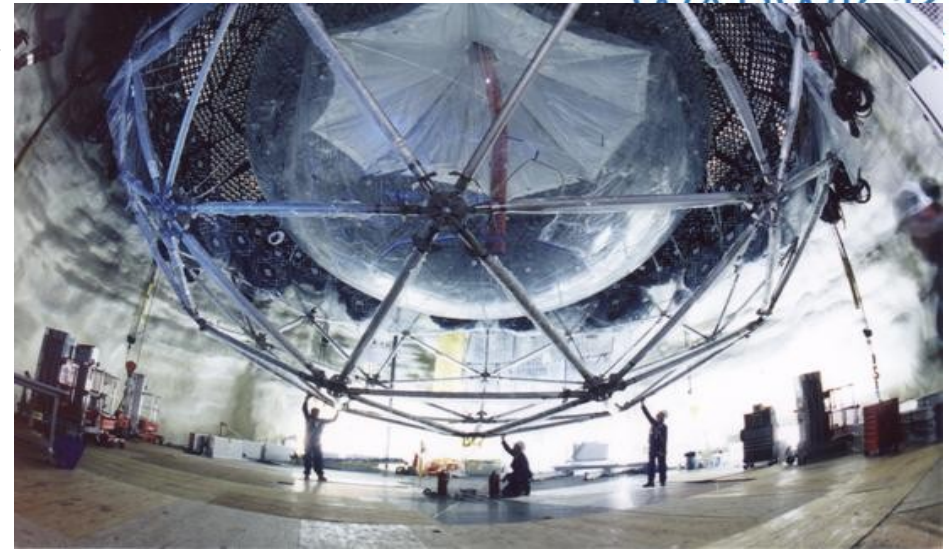
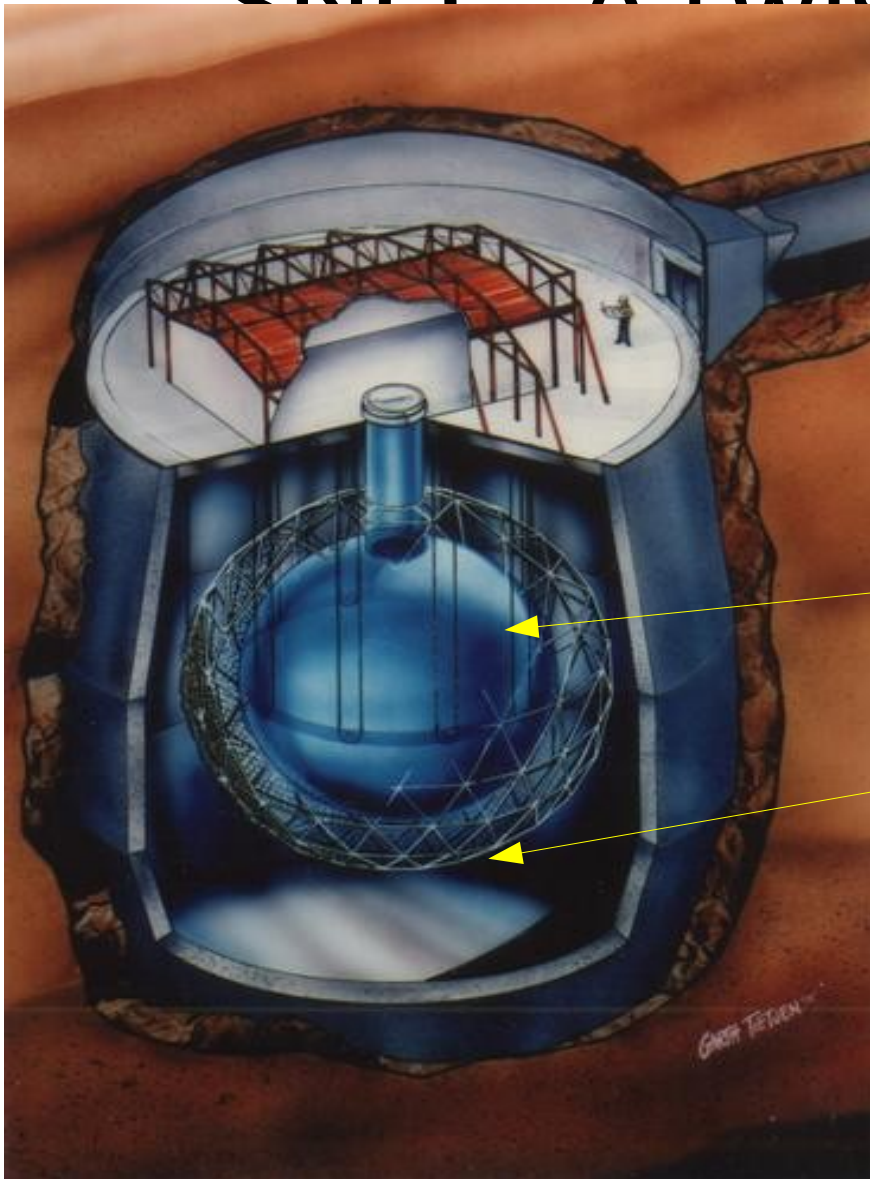

1000 tonnes of D<sub>2</sub>O

6500 tons of H<sub>2</sub>O

Viewed by 10,000 PMTS

In a salt mine 2km underground  
in Sudbury, Canada

# $\nu$ Reactions in SNO

## Charged Current Reaction:

CC

- ▮ 6-9 events per day
- ▮  $n_e$  flux and energy spectrum
- ▮ Some directional sensitivity ( $1 - 1/3 \cos \theta_e$ )

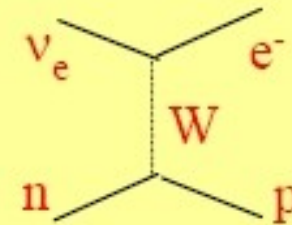

## Neutral Current Reaction:

NC

- ▮ 1-2 or 6-8 events per day (different detection mechanisms)
- ▮ Total solar  $^8\text{B}$  active neutrino flux

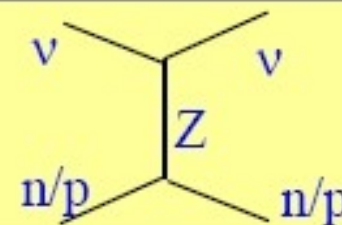

## Elastic Scattering Reaction:

ES

- ▮ 1-2.5 events per day
- ▮ Directional sensitivity (very forward peaked)

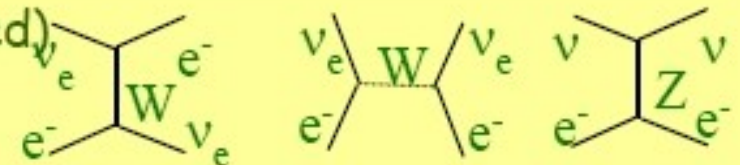

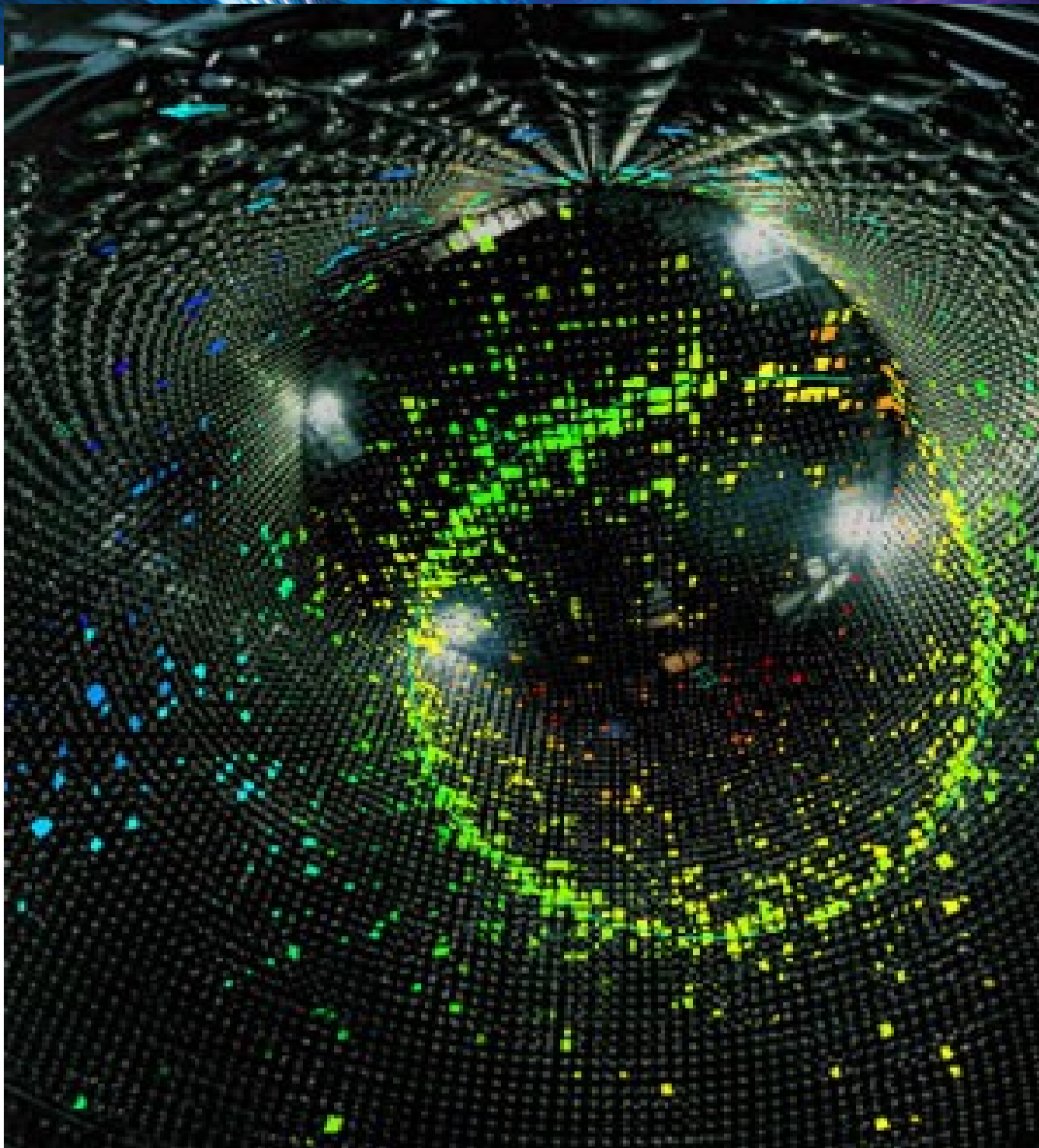

# Neutrino Detectors

- No neutrino colliders – detector IS the target
- Low cross section implies large mass
- Neutrinos interact everywhere – vertex can be anywhere
- Identification of charge lepton to separate NC and CC
- Measurement of energy and scattering angle of charged lepton
- Measurement of total hadronic energy
- Identification of single hadrons for hadronic studies
- Use of different target materials (nuclear effects)

No experiment can satisfy all these requirements  
Most experiments fall into one of a few types

# Weak Interaction

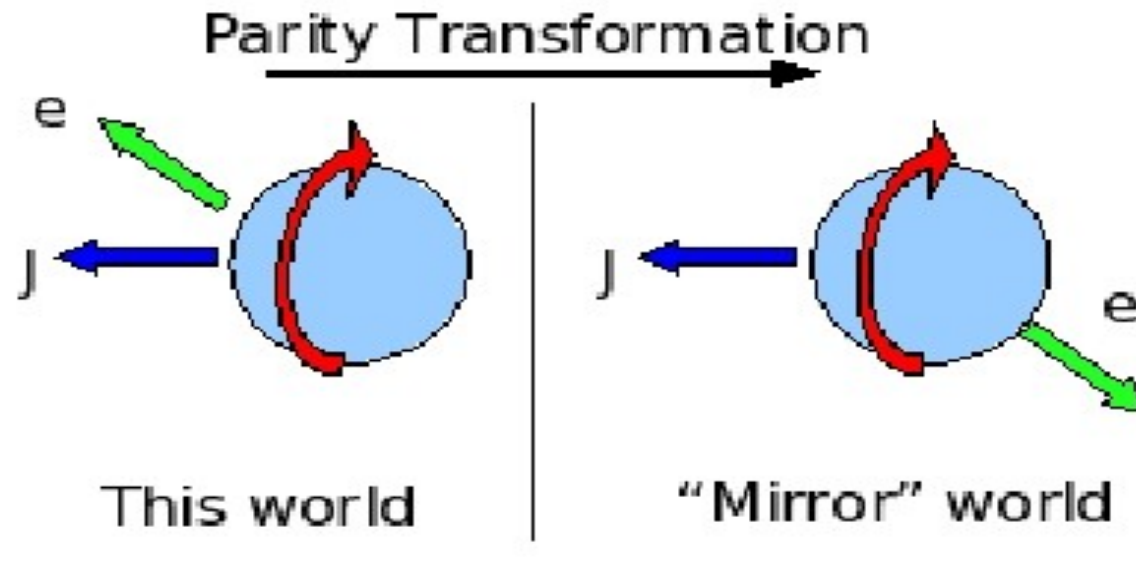

$P(\text{world}) = P(\text{mirror})$  if parity conserved  
So electron must be emitted isotropically

It isn't. In fact it's emitted along only one direction so parity is maximally violated. That is the weak interaction only couples left-handed (chiral) particles

Simple, no magnetic field; limited by size.  
 Reconstructed energy: build range table,  
 integrating Bethe-Bloch; incorporate each layer  
 of differing material.(ask GEANT for help)

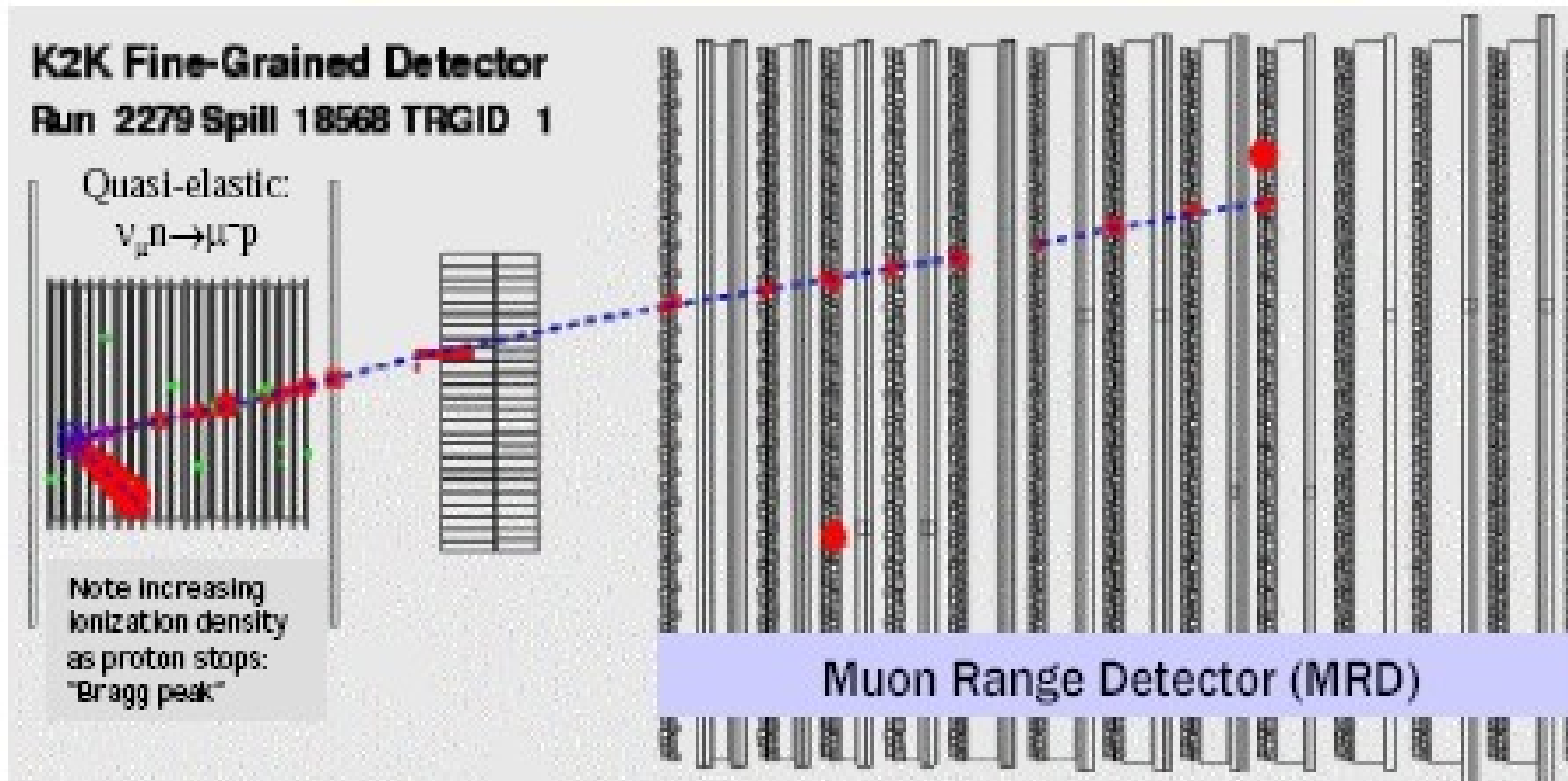

$$dE/dx)_{Fe} = 1.45 \text{ MeV g}^{-1}\text{cm}^2 \times 7.9 \text{ gm cm}^{-3} = 90 \text{ MeV/cm} \dots 1 \text{ GeV muon travels } \sim 1\text{m}$$

(careful use of range chart, eg. in PDG, gives 80 cm)

# NuTeV Fit

$$\sin^2 \theta_W^{(on-shell)} = 0.2277 \pm \pm 0.0013(stat.) \pm 0.0009(syst.)$$

$$= 0.2277 \pm 0.0016$$

(Previous neutrino measurements gave  $0.2277 \pm 0.0036$ )

- Standard model fit (LEPEWWG):  $0.2227 \pm 0.00037$

A  $3\sigma$  discrepancy .....

$R_{\text{exp}}^\nu = 0.3916 \pm 0.0013$ $(SM : 0.3950) \Leftarrow 3\sigma \text{ difference}$ $\bar{R}_{\text{exp}}^\nu = 0.4050 \pm 0.0027$ $(SM : 0.4066) \Leftarrow \text{Good agreement}$
---

68%,90%,95%,99% C.L. Contours, Grid of SM  $\pm 1\sigma$  mtop, mHiggs

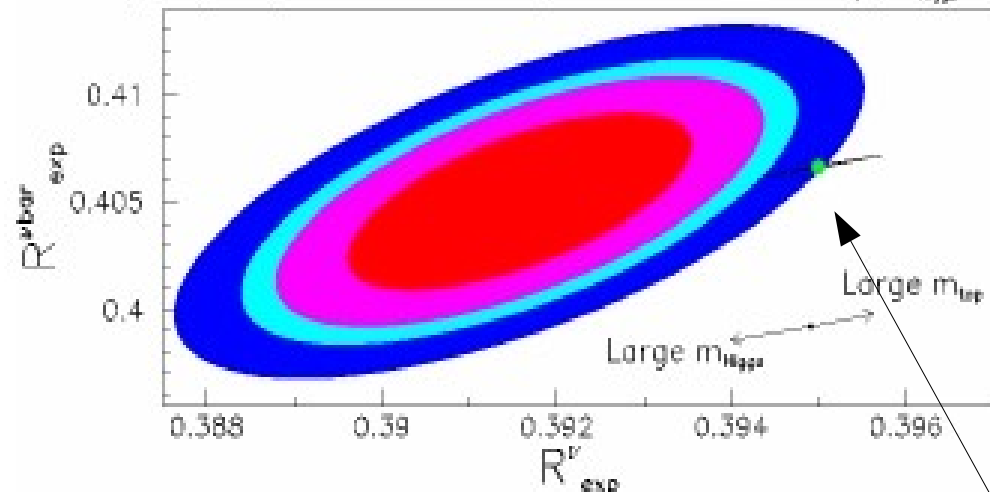

$$R^\nu = \frac{\sigma_{NC}(\nu N)}{\sigma_{CC}(\nu N)}; R^{\bar{\nu}} = \frac{\sigma_{NC}(\bar{\nu} N)}{\sigma_{CC}(\bar{\nu} N)}$$

Standard Model measurement

# Incidentally - A Puzzle

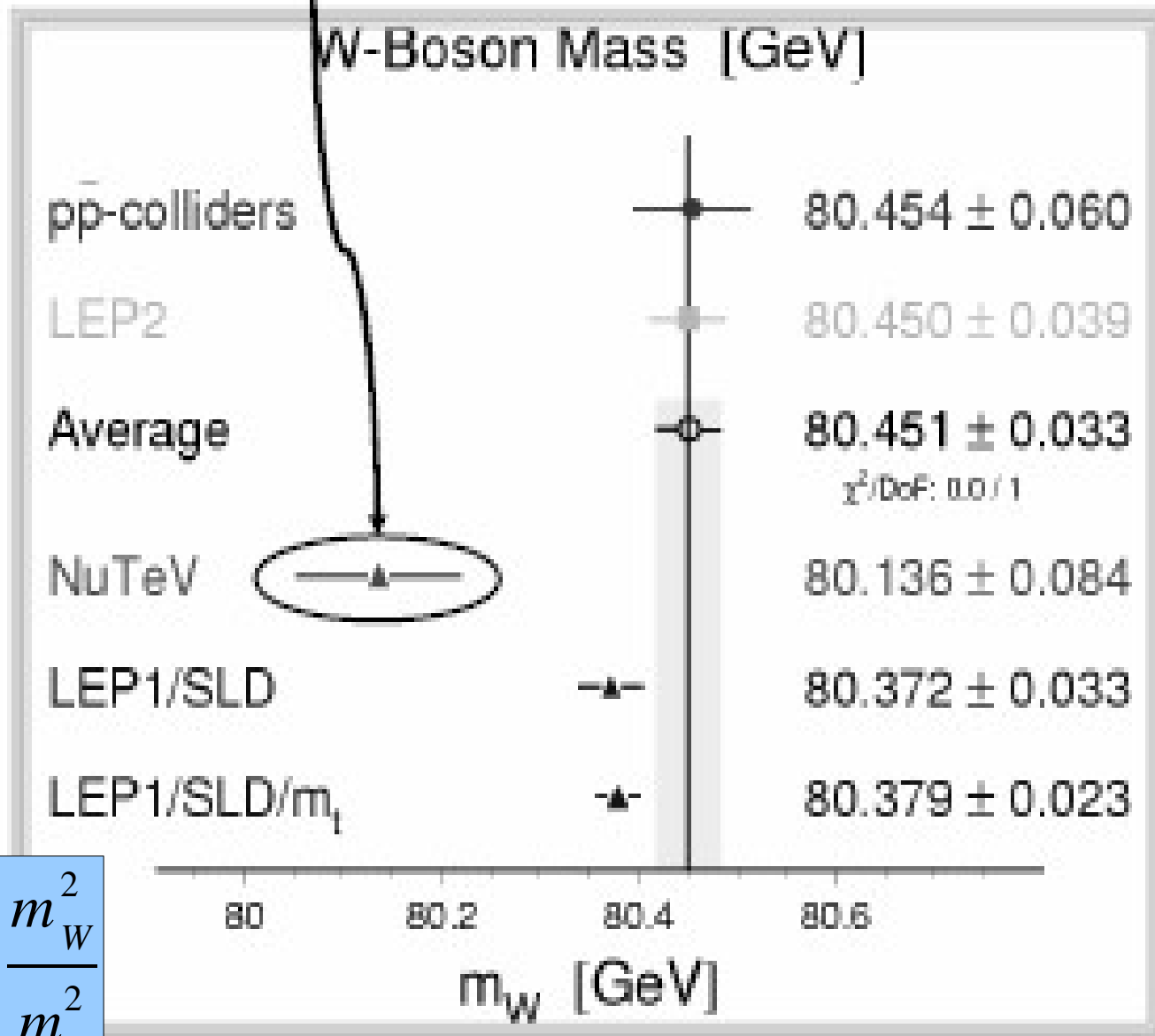

$$\sin^2 \theta_w = 1 - \frac{m_W^2}{m_Z^2}$$

# Possible

- ## interpretations
- *New Beyond-Standard-Model physics?*
    - Difficult to find something which does this just for  $\nu$
  - *Purely experimental*
    - Multiple checks. Not obvious if it is.
  - *Mundane explanations*
    - Charm mass effects
    - Radiative effects
    - Isospin symmetry violation :  $u_p(x) \neq d_n(x)$
    - Strange/anti-Strange sea asymmetry :  $\int s(x) \neq \int \bar{s}(x)$   
(intrinsic strangeness?)
    - Different nuclear effects for NC over CC (Z over W)



# Fermi Operators

$$H = \sum_i C_i \int d^3x (\bar{\psi}_p \Gamma_i \psi_n) (\bar{\psi}_e \Gamma_i \psi_\nu)$$

General LI Operator :  $\Gamma_i \in 1, \gamma_5, \gamma_\mu, \gamma_\mu \gamma_5, \sigma_{\mu\nu}$

	$\Gamma_i$	Parity
S	1	1
V	$\gamma_\mu$	(+, -, -, -)
T	$\sigma_{\mu\nu}$	
AV	$\gamma_\mu \gamma_5$	(+, +, +, +)
PS	$\gamma_5$	-1

Mixture which maximally violates parity is found to be

$$\Gamma_i = \gamma_i (1 - \gamma_5)$$

**V-A coupling**

# Fermi Couplings

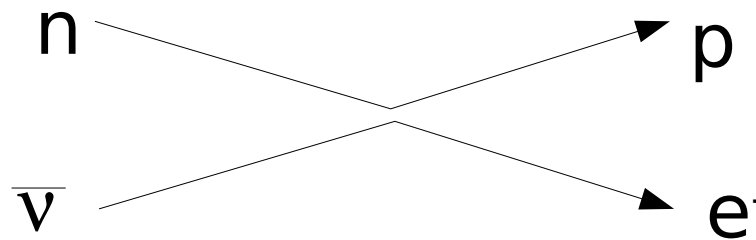

$$L = G_F [\bar{\phi}_p(x) \gamma^\mu \phi_n(x)] [\bar{\phi}_e(x) \gamma_\mu \phi_\nu(x)]$$



$$L \propto G_F [\bar{\phi}_p(x) \gamma^\mu (g_V - g_A \gamma_5) \phi_n(x)] [\bar{\phi}_e(x) \gamma_\mu (1 - \gamma_5) \phi_\nu(x)]$$

V-A interaction

An intrinsic property of the Weak Interaction

# Neutrino Flavour

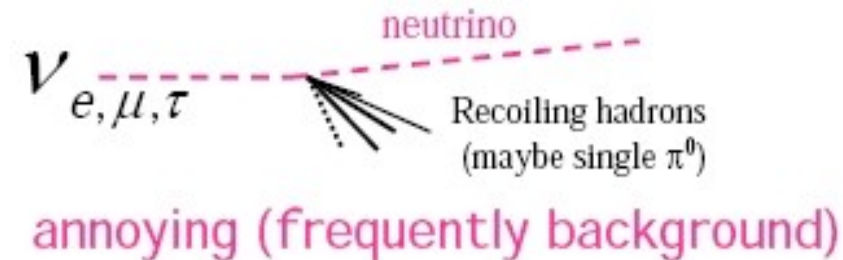
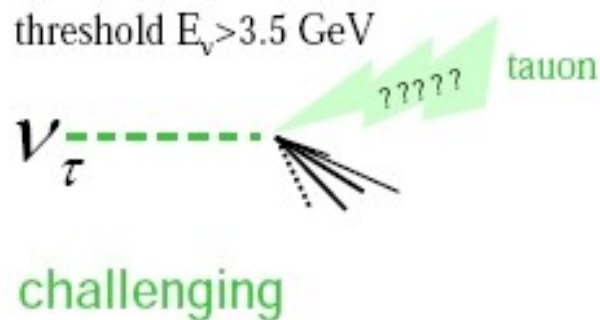
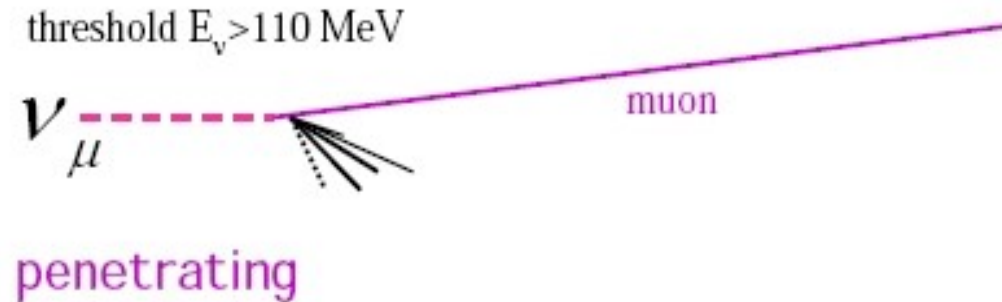
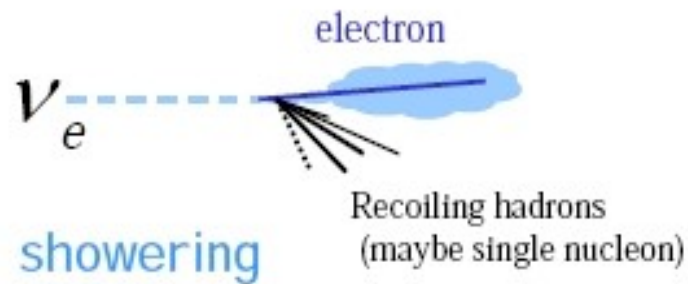

- $\tau \rightarrow e\nu\nu$  18%
- $\rightarrow \mu\nu\nu$  18%
- $\rightarrow 3\pi\nu$  14%
- $\rightarrow \pi\nu$  11%

*In which neutrinos reluctantly interact*

# A neutrino can see....

- Very low  $Q^2$ ,  $\lambda > r_p$ , and scattering is off a “point-like” particle
- Low  $Q^2$ ,  $\lambda \sim r_p$ , scattering is off an extended object
- High  $Q^2$ ,  $\lambda < r_p$ , can resolve quark in the nucleon
- Very High  $Q^2$ ,  $\lambda \ll r_p$ , can resolve sea of quarks and gluons in nucleon

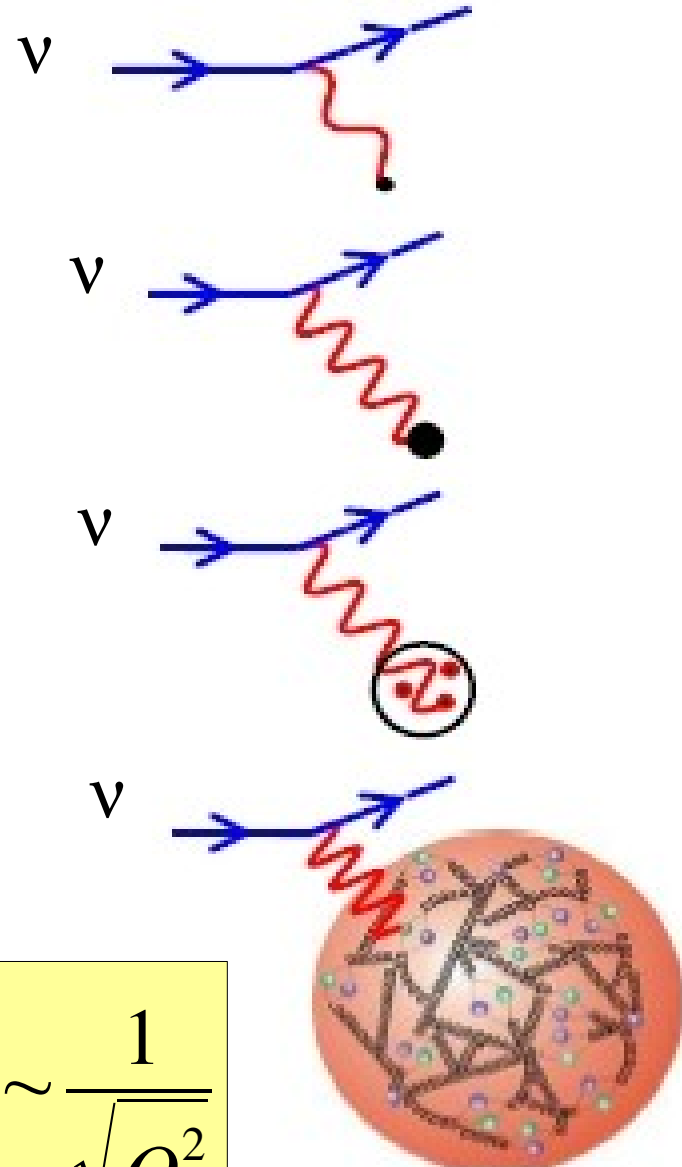

$$\lambda = \frac{1}{p} \sim \frac{1}{\sqrt{Q^2}}$$

# Neutrino-Nucleon Interactions

## CC - $W^\pm$ exchange

- Quasi-elastic Scattering  
Target changes but no breakup  
 $\nu_\mu + n \rightarrow \mu^- + p$
- Coherent/Diffractive production  
Target unchanged  
 $\nu_\mu + n \rightarrow \mu^- + n + \pi^+$
- Nuclear resonance production  
Target goes to excited state and decays  
 $\nu_\mu + n \rightarrow \mu^- + p + \pi^0$  ( $N^*$  or  $\Delta$ )  
 $n + \pi^+$
- Deep Inelastic Scattering  
Target breaks up  
 $\nu_\mu + \text{quark} \rightarrow \mu^- + \text{quark}'$



## NC - $Z^0$ exchange

- Elastic Scattering  
Target unchanged  
 $\nu_\mu + n \rightarrow \nu_\mu + n$
- Coherent/Diffractive production  
Target unchanged  
 $\nu_\mu + N \rightarrow \nu_\mu + N + \pi^0$
- Nuclear resonance production  
Target goes to excited state and decays  
 $\nu_\mu + N \rightarrow \nu_\mu + N + \pi$  ( $N^*$  or  $\Delta$ )
- Deep Inelastic Scattering  
Target breaks up  
 $\nu_\mu + \text{quark} \rightarrow \nu_\mu + \text{quark}$

# Cross-sections – current knowledge



$\nu_{\mu}$

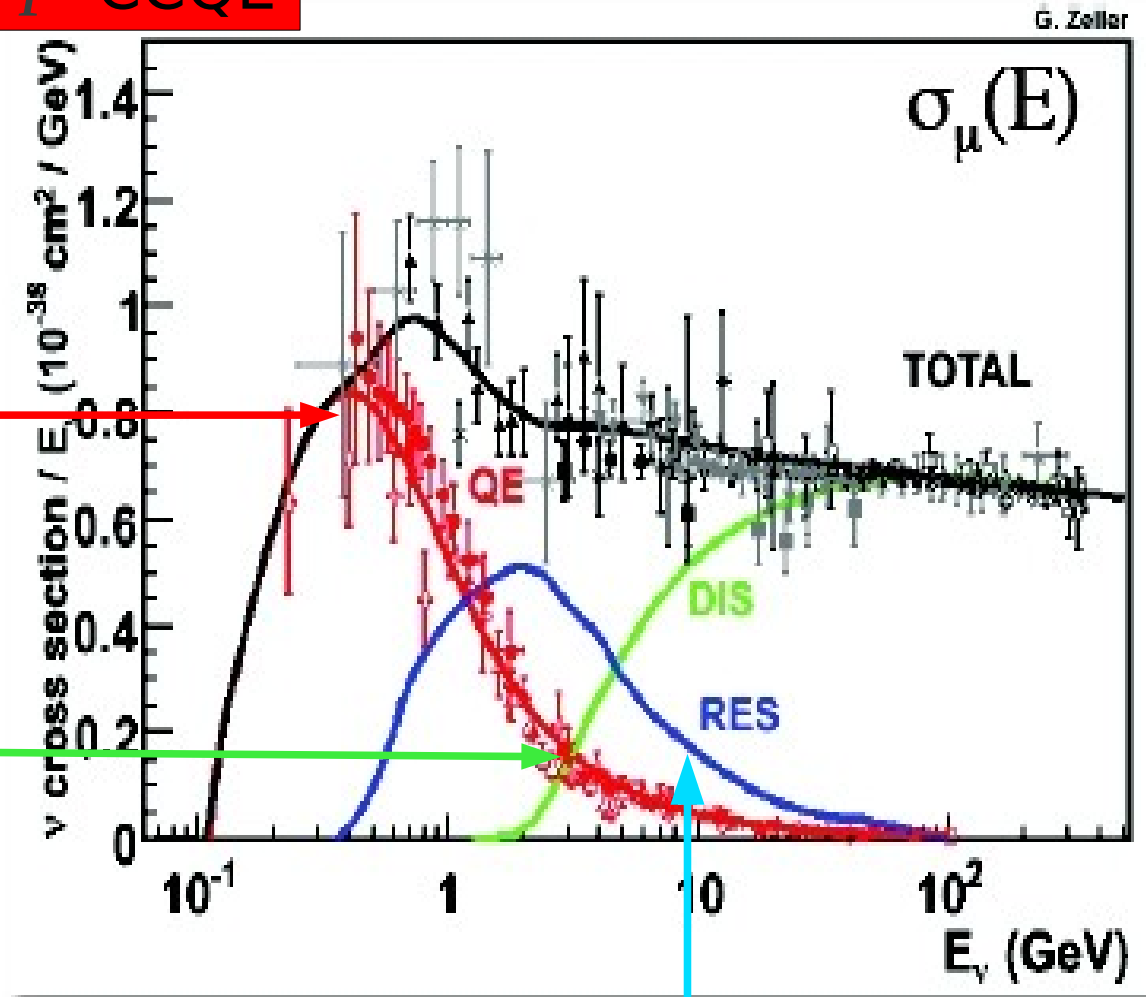

“Transition Region”



# CCQE - Experimental signature

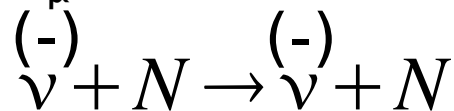
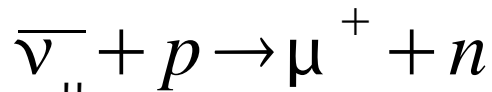
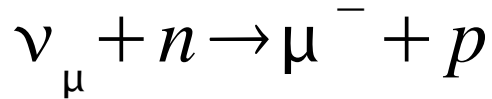

Proton id from dE/dx  
 Muon id from range  
 Two-body so angles  
 are known if  $E_{\mu}$  is  
 known

$$E_{\nu} = \frac{m_N E_{\mu} - m_{\mu}^2 / 2}{m_N - E_{\mu} + p_{\mu} \cos \theta_{\mu}}$$

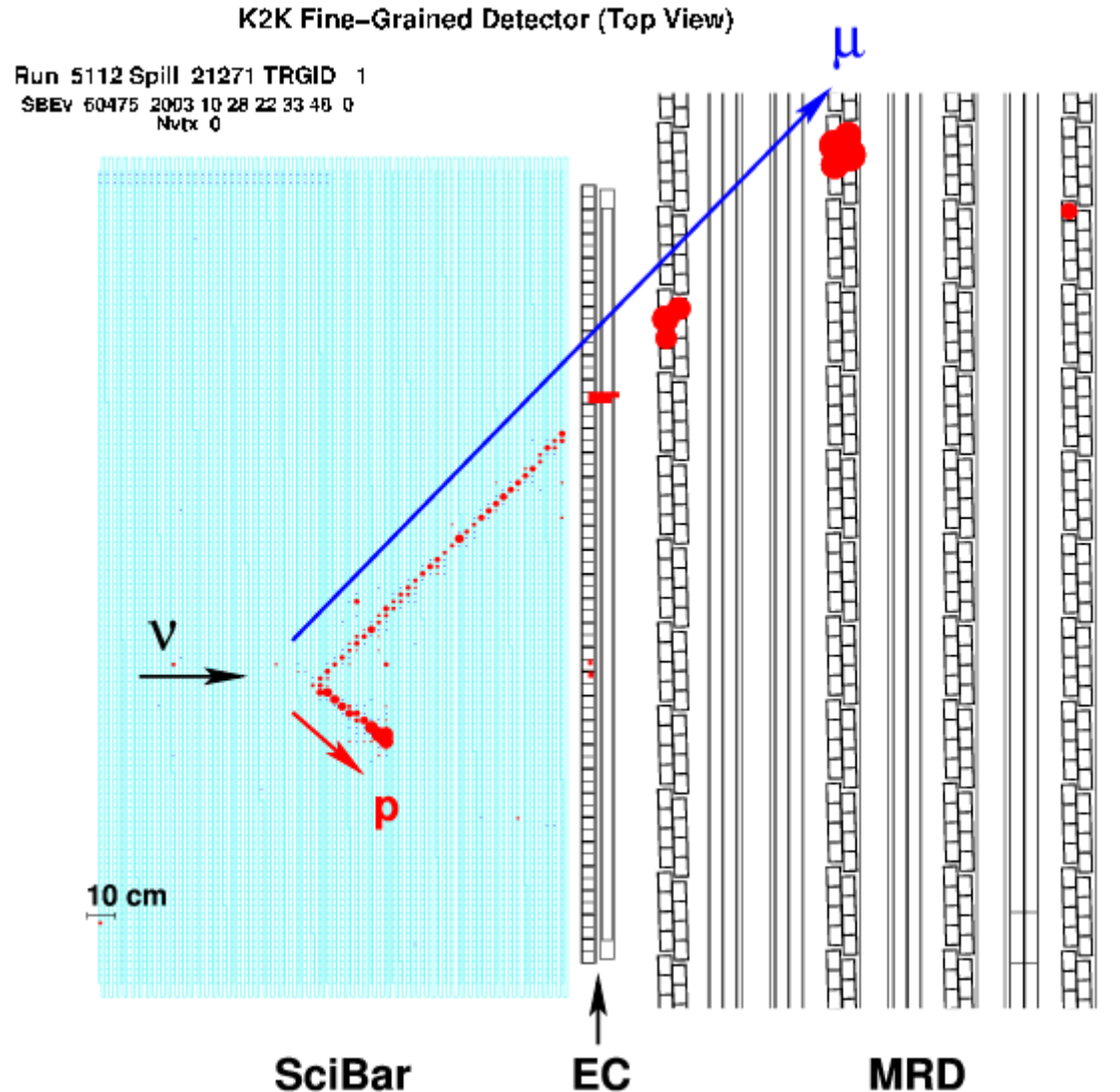

# Problems with QE

The CC QE process is the best known neutrino process occurring at a few GeV

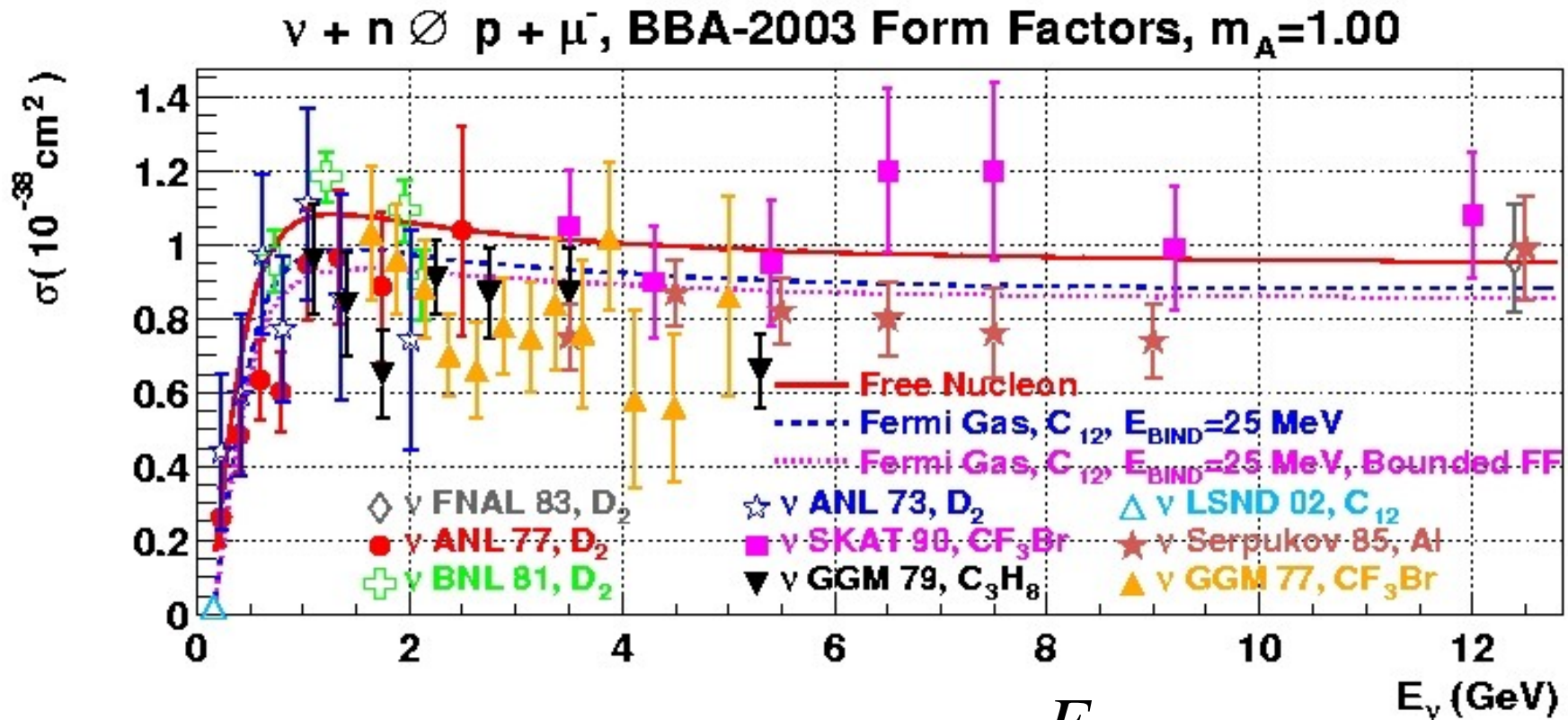

$$\sigma_{QE} \sim 0.975 \times 10^{-38} \left( \frac{E_\nu}{1 \text{ GeV}} \right) \text{ cm}^2$$

# It's getting better

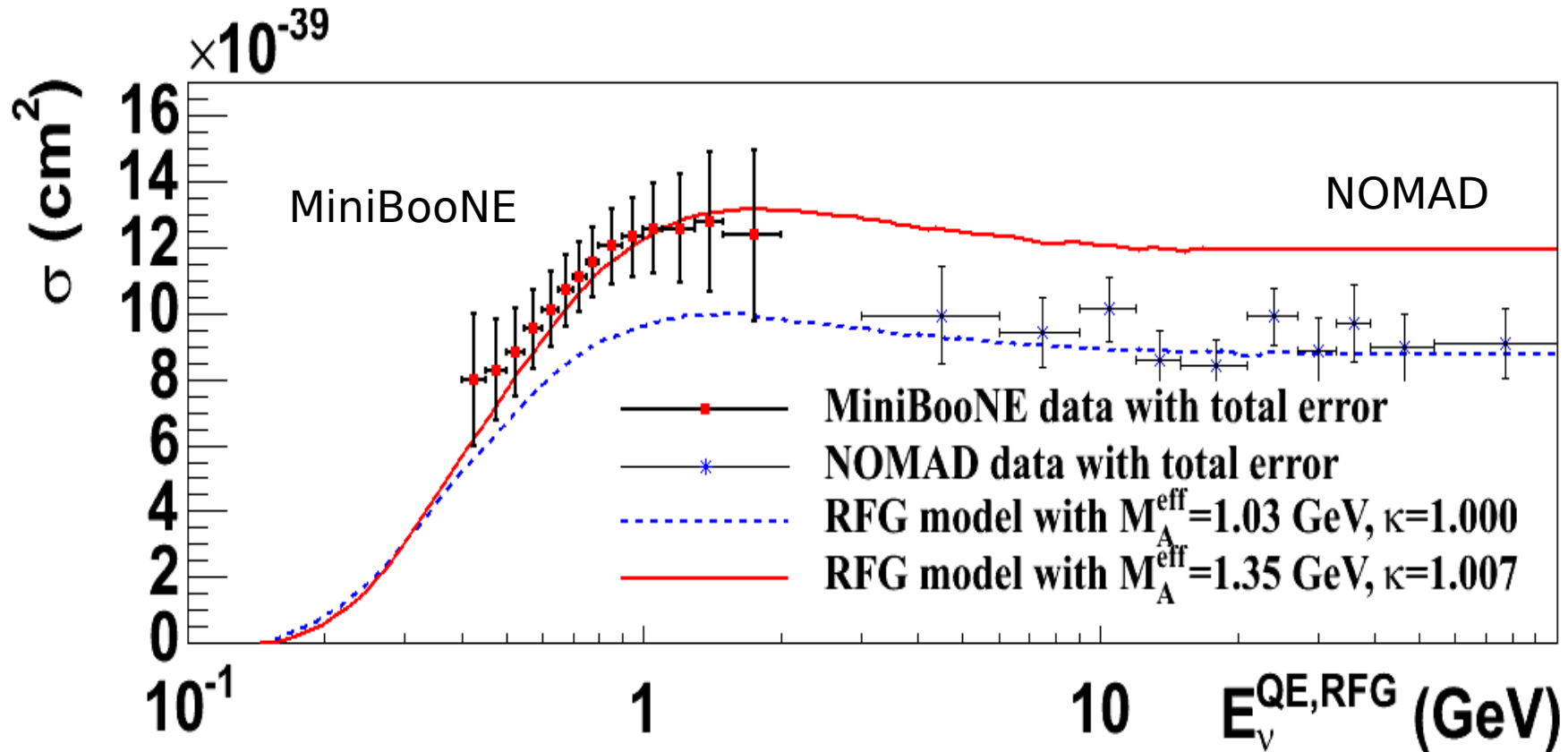

Note tension between low and high energy measurements

Both on carbon target

Y. Nakajima *NuInt11*

# Resonance Region

The data is impressively imprecise

CC Single Pion Production

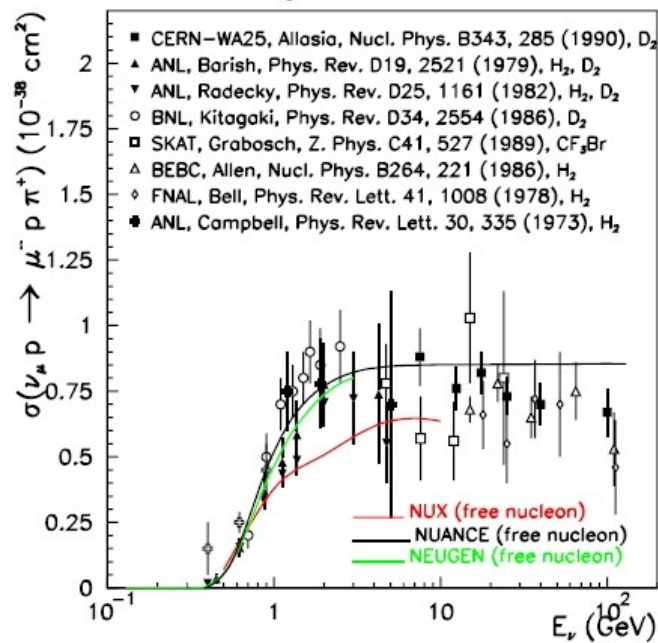

Multi Pion Production

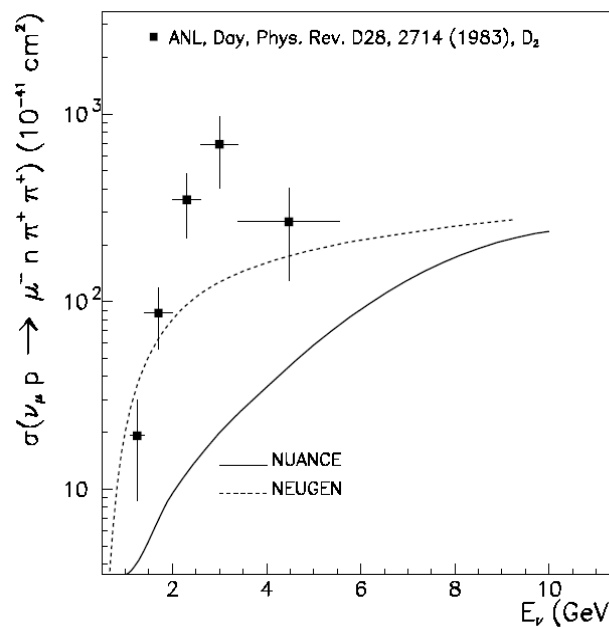

NC Single Pion Production

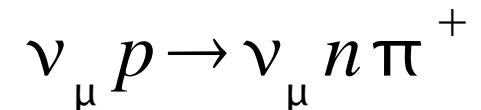
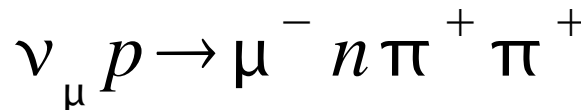
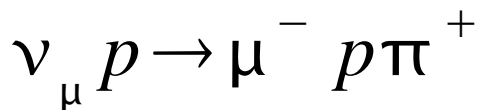
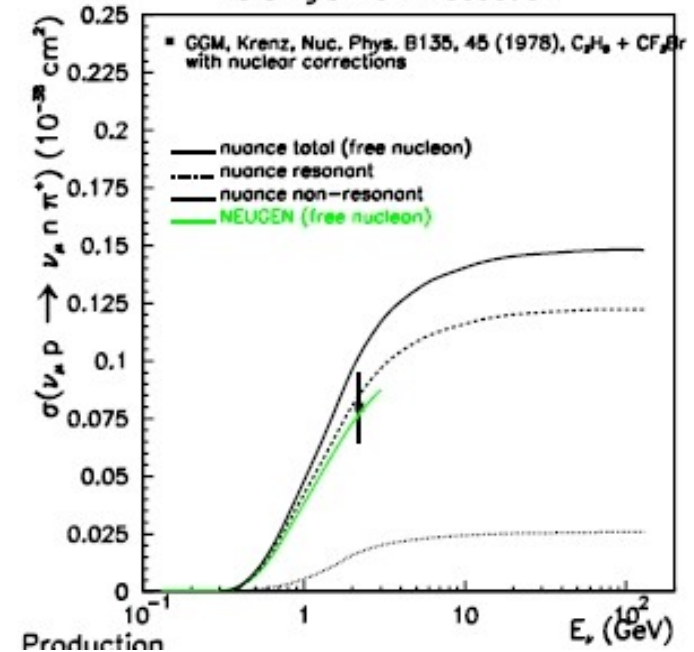

Added complication that the final state pions can (i) scatter (ii) be absorbed (iii) charge exchange within the nucleus before being observed (iv) nucleons rescatter producing  $\pi$

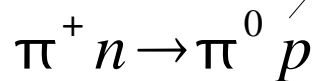

# Sort-of getting better

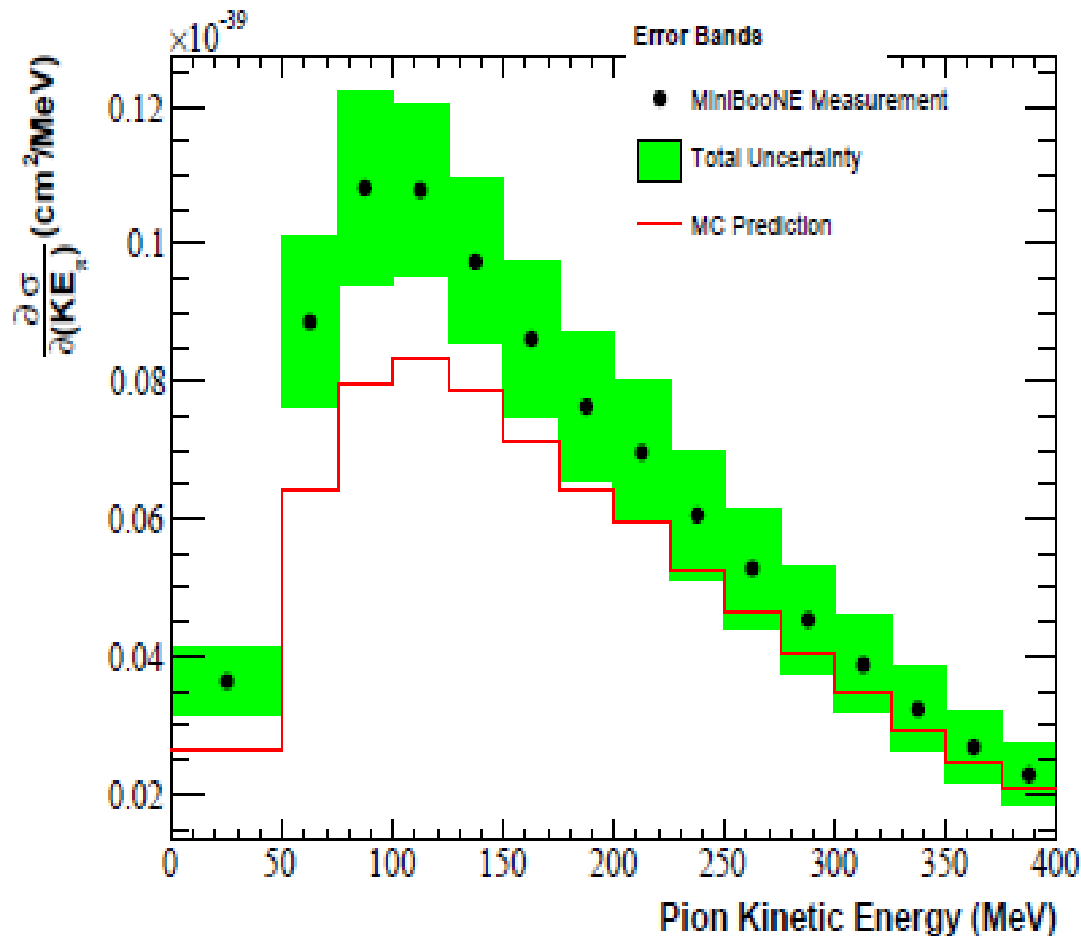

- ▶ Cross section for CC  $\nu$  interactions producing a single  $\pi$  exiting the nucleus
- ▶ Data from NOMAD, SciBooNE, T2K & K2K also available or becoming available

MiniBooNE

# Problems we haven't really mentioned

1. We are assuming that the initial target nucleon is just sitting still before interaction. Actually in the nucleus it has some initial momentum distribution.

The **Fermi momentum** modifies the scattering angles and momentum spectra of the outgoing final state

2. The outgoing final state can interact with the target nucleus.

This **nuclear re-interaction** affects the outgoing nucleon momentum direction and charge (through charge exchange interactions)

Theoretical uncertainties are **large**

- At least 15%
- If precise knowledge is needed for a particular target (e.g. Water, hydrocarbon) then measurements are needed
- Last measurements taken in the '70s

# CCQE and Nuclear Effects

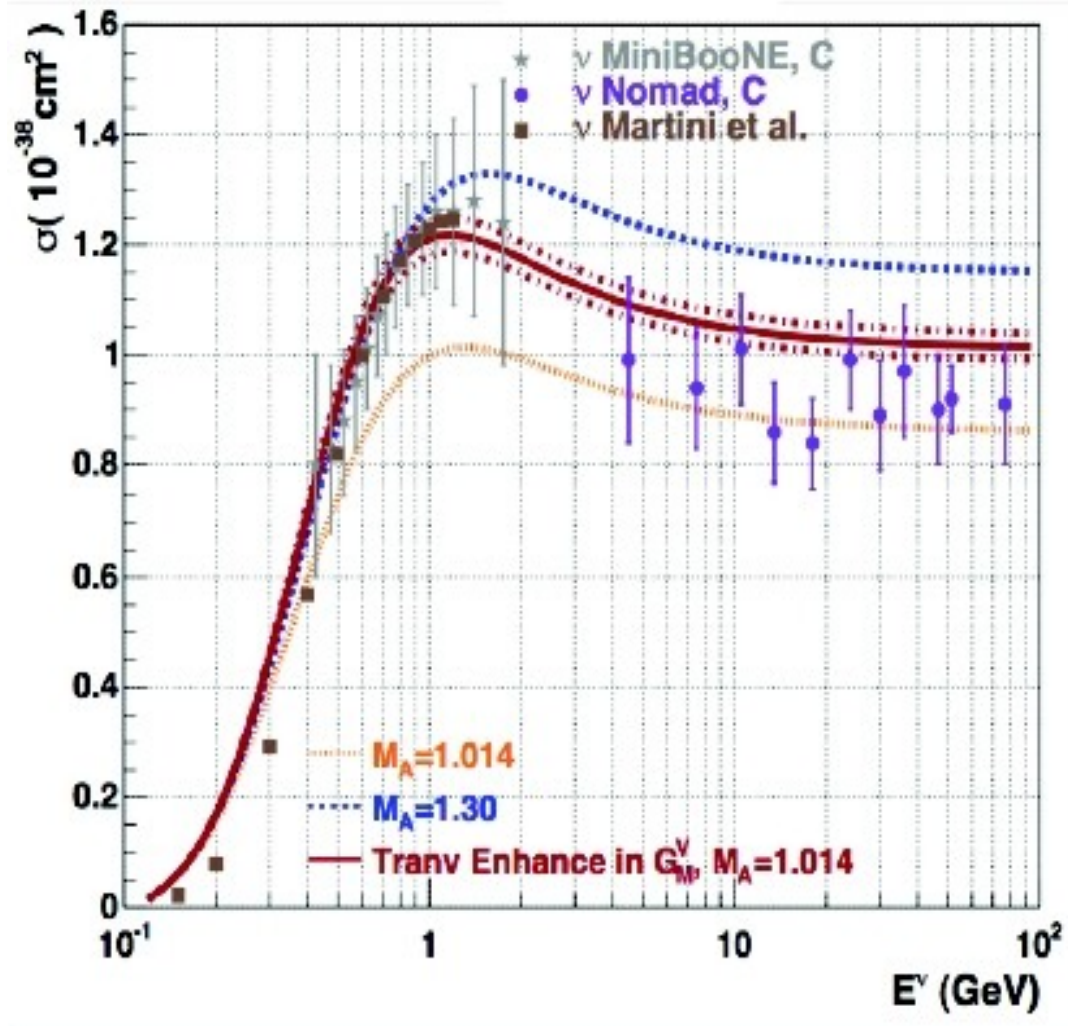

Bare interaction

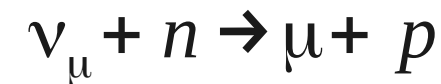

Nucleon-correlations

Low  $Q^2$  probe can be shared by neighbouring nucleons in nuclear target

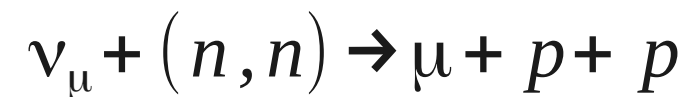

# Resonance and Nuclear Effects

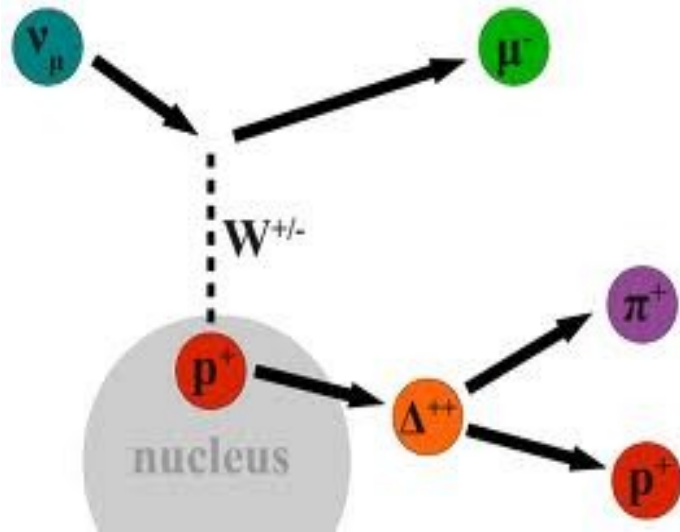

Nuclear  
rescattering

Charge  
exchange

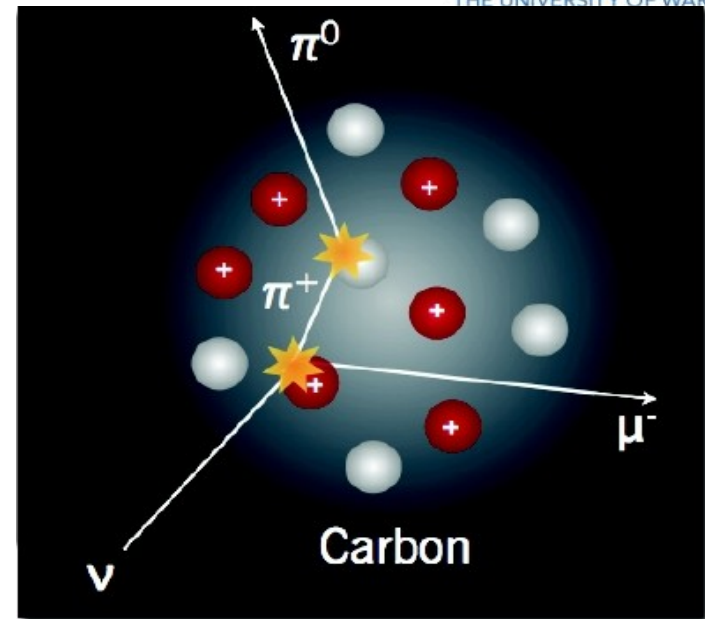

$$\nu_\mu + p \rightarrow \Delta^{++} \rightarrow \pi^+ + p$$

$$\nu_\mu + p \rightarrow \Delta^{++} \rightarrow \pi^+ + p \rightarrow \pi^0 + p$$

In the past few years neutrino physics has gone from basic tree-level physics to an understanding that (i) nuclear effects are important (ii) we don't know enough about them and (iii) theorists and the electron scattering community can really help here.

# World Data for Antineutrinos

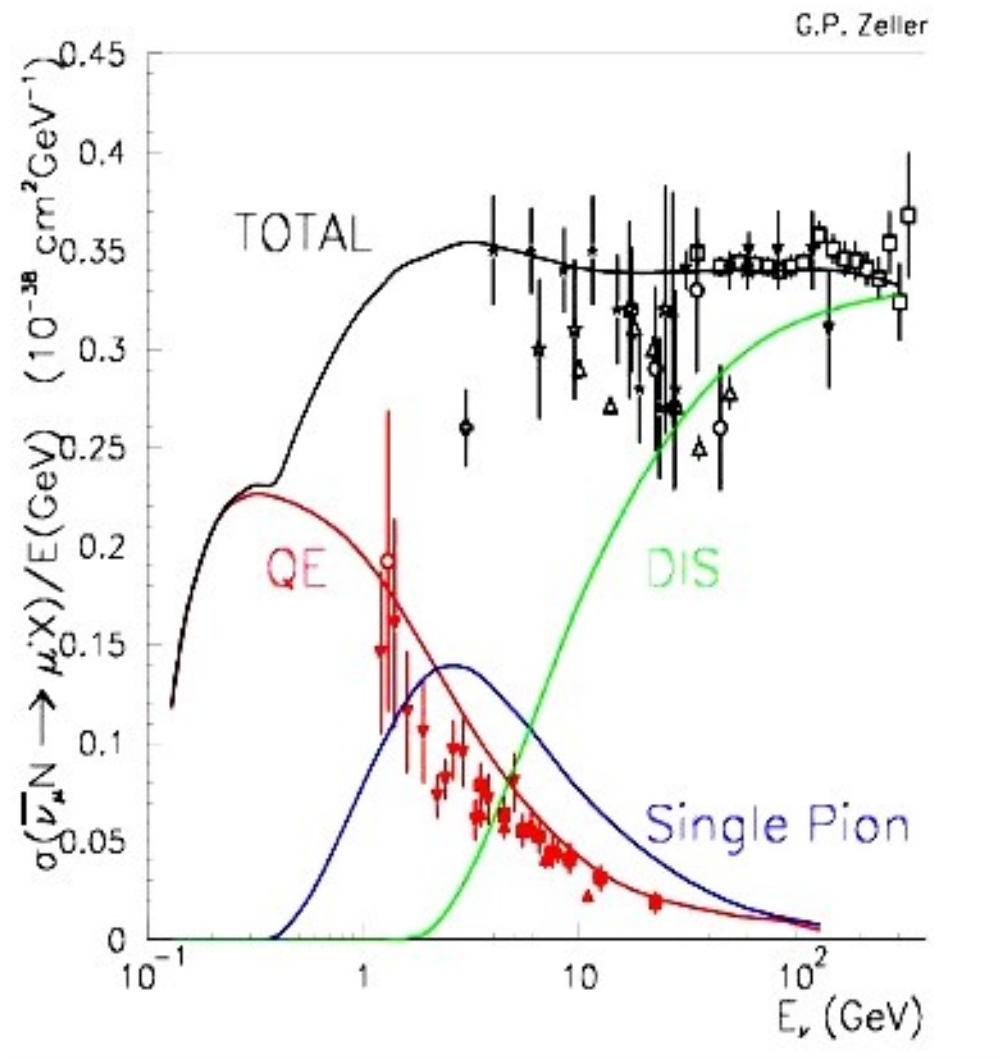

# Weak Interaction

- Until 1956 everybody assumed that the weak interaction, like the electromagnetic interaction, conserved parity
- This was found to be false (see Lee&Yang, Wu)
- Weak interaction maximally violates parity in that it only couples to left-handed chiral particles and right-handed chiral antiparticles
- This is the so-called V-A theory of weak currents
- This has implications for neutrinos

# Helicity and Chirality

• **Helicity** is the projection of spin along the particles direction

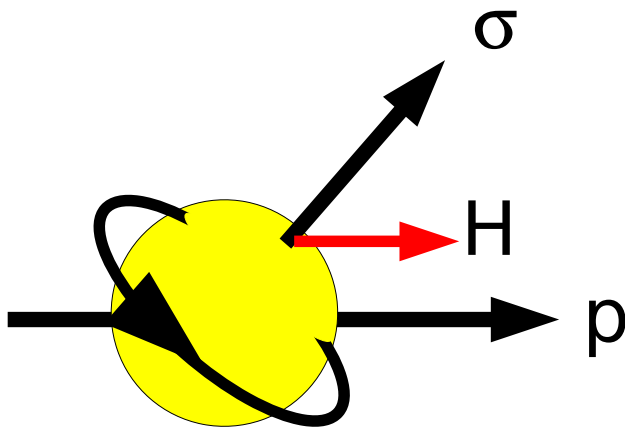

$$\hat{H} = \frac{\vec{\sigma} \cdot \vec{p}}{|\vec{p}|}$$

H is not Lorentz Invariant unless particle is massless

Something is **chiral** if it cannot be superimposed on its mirror image

Not directly measurable but is Lorentz invariant

$$P_{+-} = \frac{(1 \pm \Lambda)}{2} \rightarrow P_{L,R} = \frac{(1 \pm \gamma_5)}{2}$$

**Handedness  $\neq$  Chirality**

In the limit of *zero mass*, chirality = helicity

A massive left-handed particle may have both helicity states

# Implication for neutrinos

- Neutrinos only interact weakly through a V-A interaction
- If Neutrinos are massless then
  - Neutrinos are always left-handed (chiral) and have left-handed helicity
  - Antineutrinos are always right-handed (chiral) and have right-handed helicity
    - Because of **production**
- If Neutrinos have mass then
  - It is possible to observe a neutrino with *right-handed* helicity (but NOT chirality)
    - $$P(\text{"wrong-sign" helicity}) \propto (m/E)^2$$
  - A right-handed chiral neutrino might exist - it just can't couple to any of the forces