

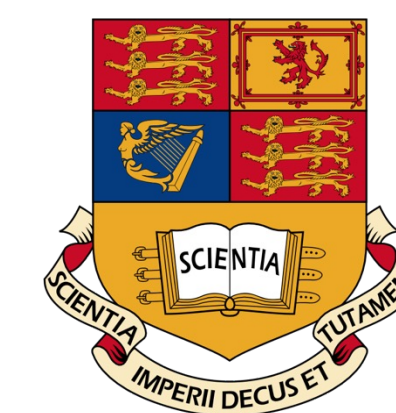

Particle Physics Colliders and Beamlines

ADRIAN OEFTIGER & STEPHEN GIBSON
JAI ADVISORY BOARD, 16 APRIL 2026



Imperial College
London

Overview

1. CERN's High-Luminosity LHC

- Machine protection & diagnostics
- Nonlinear dynamics
- Data-driven modelling
- Coherent stability

2. Future electron-positron Higgs Factories

- Linear colliders and leading contributions + ATF3
- FCCee IP feedback + BPM diagnostics

3. More Colliders and Fixed-Target Facilities

- Facility for Antiproton and Ion Research
- Electron-Ion Collider
- Muon Collider & NuSTORM

1. CERN's High Luminosity Large Hadron Collider



HL-LHC-UK Project & funding

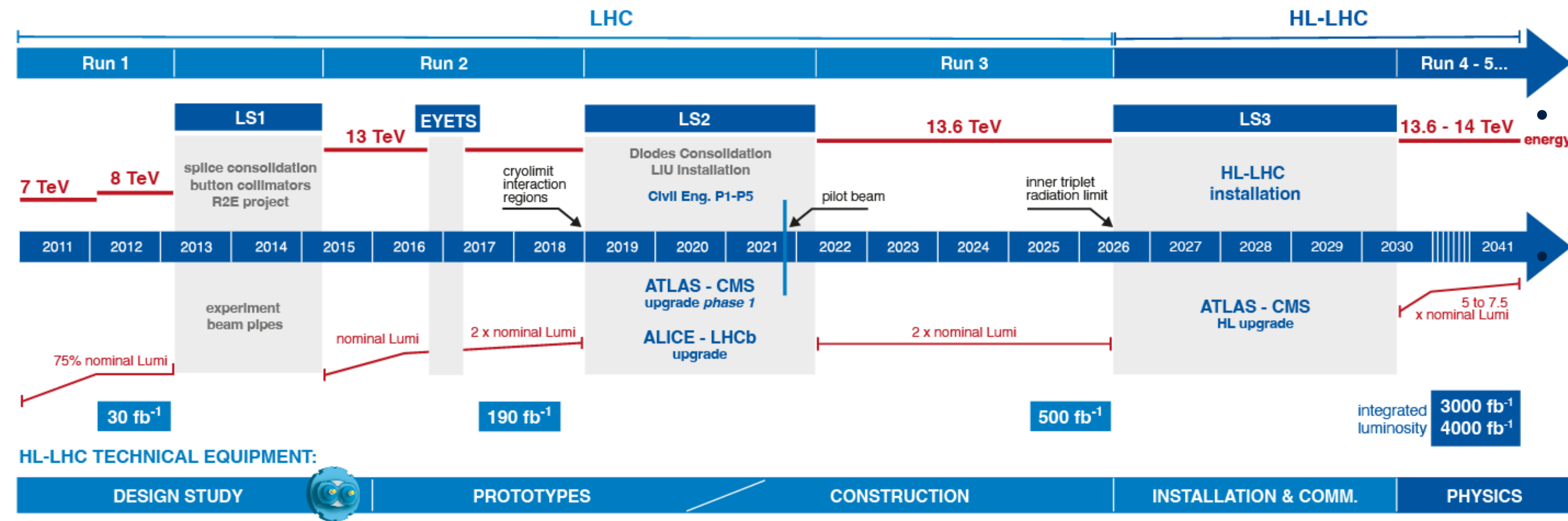

• Long history of UK contributions to HL-LHC

Major collaborative project funded from multiple

sources:

- Accelerator Institute grants
- CERN
- STFC project grant
- University contributions



UKRI PPAN prioritisation exercise: HL-LHC-UK phase 3 proforma submitted in March 2026:

- Minimal programme: Manchester, Lancaster, STFC, Southampton
- Full programme: + Liverpool, Dundee, Royal Holloway, Oxford

Without phase 3 STFC project grant, ongoing work can only continue with limited support of institute grants

LHC BPM consolidation

Weida Zhang, Philip Burrows

BPM prototype design in Oxford:

- BPM design requires combining pickup signals at very high strength
- Bulk resistors (as large as 2512 package size) have to be used
- Wideband nature of the pulses requires careful design and simulation of the circuit EM property
- Thin PCB substrate is chosen for allowing heat transferring from resistive components to enclosure
- AlN (Aluminium Nitride) ceramic is used as intermedium heatsink for
 - Avoiding non-all-ground bottom layer to have direct contact with metal heatsink, which maintains the EM property of the circuit
 - Providing $170\text{W}/(\text{mK})$ thermal conductivity to relay the heat to metal enclosure

⇒ **close to final design: >2000 need to be manufactured!**

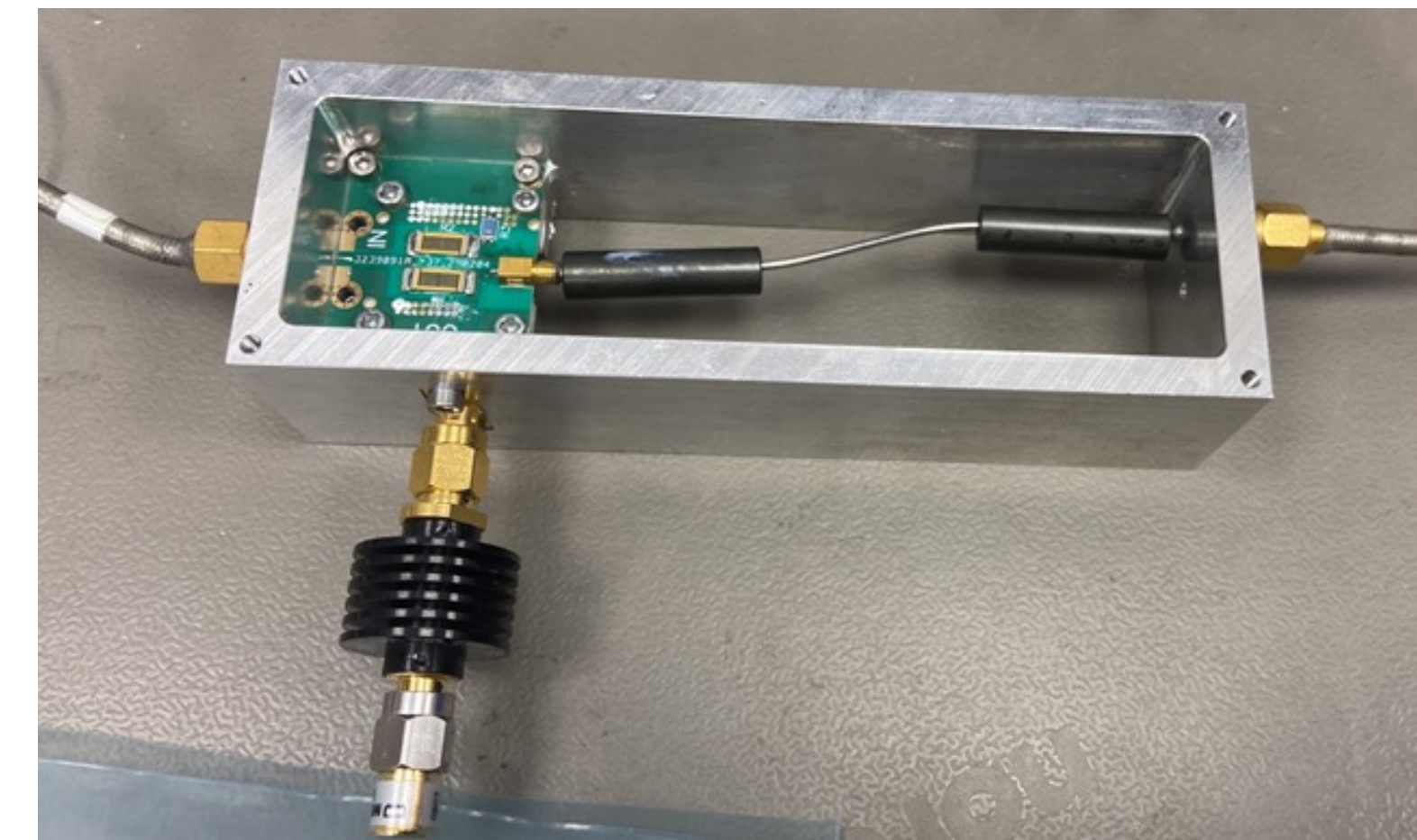

Prototype combiner

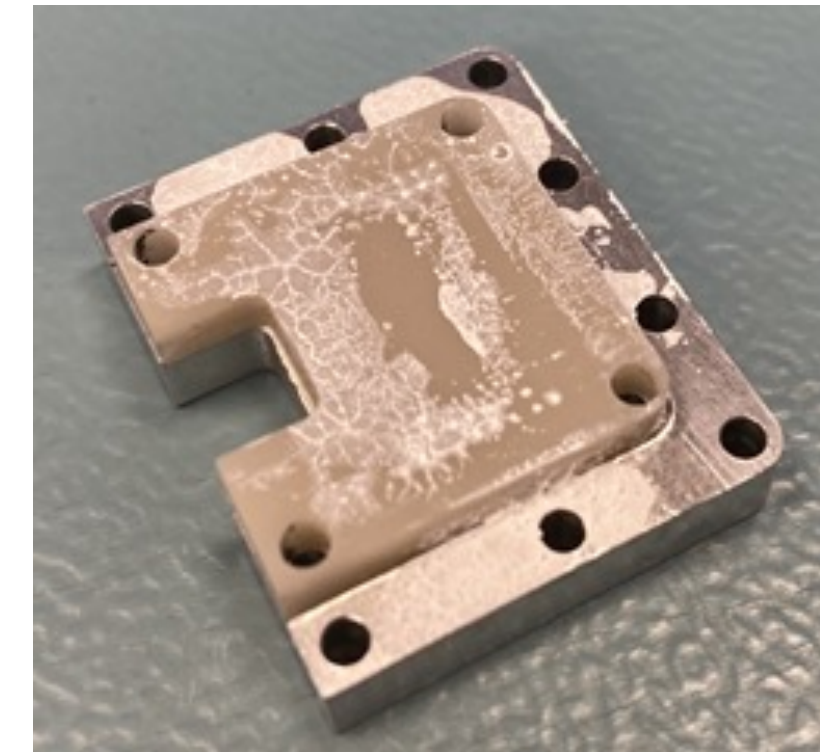

Heat sink



Thermal simulations

HL-LHC Interaction Region BPMs

HL-LHC-UK Task 3.3 complete

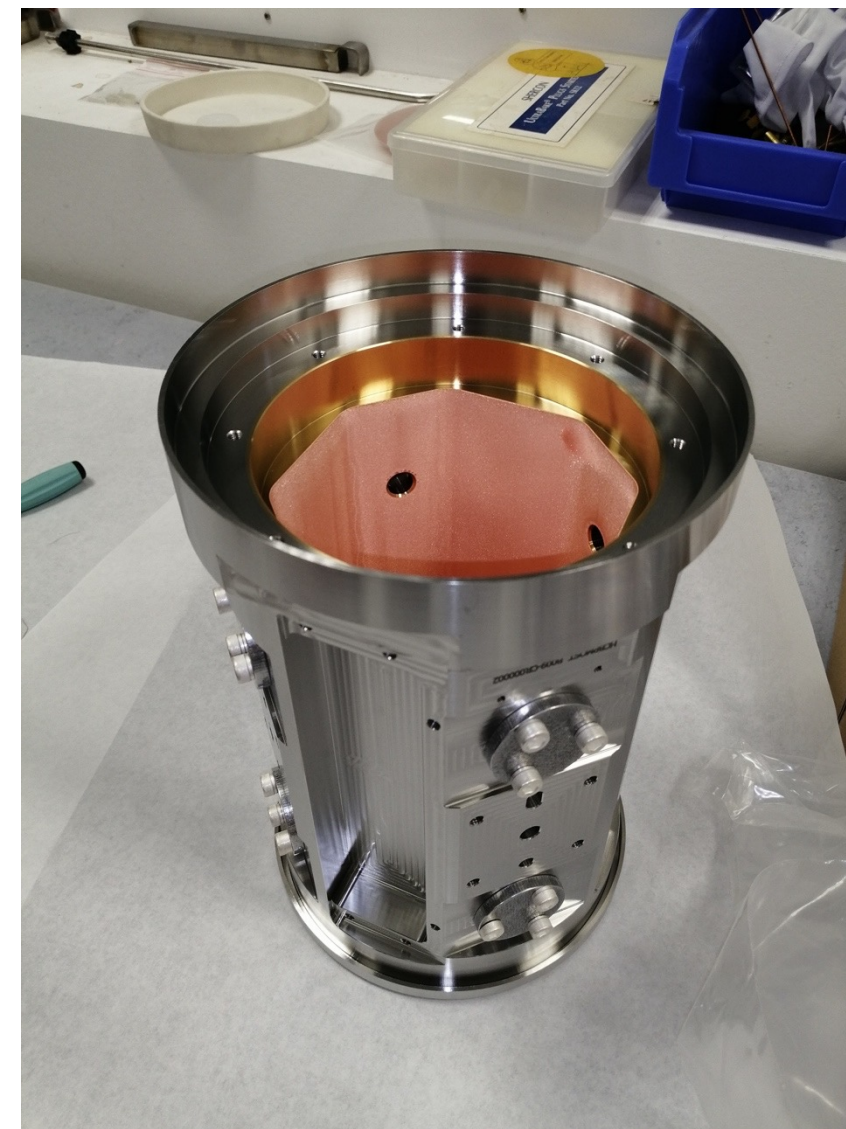
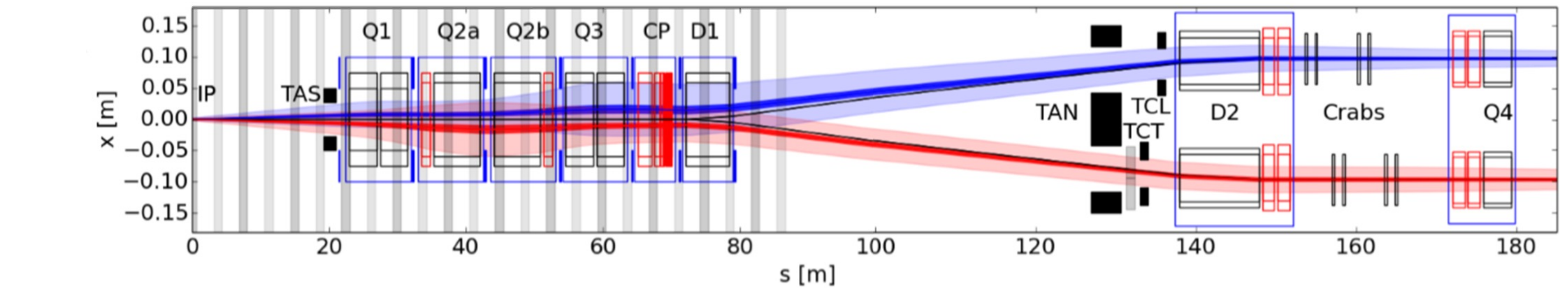
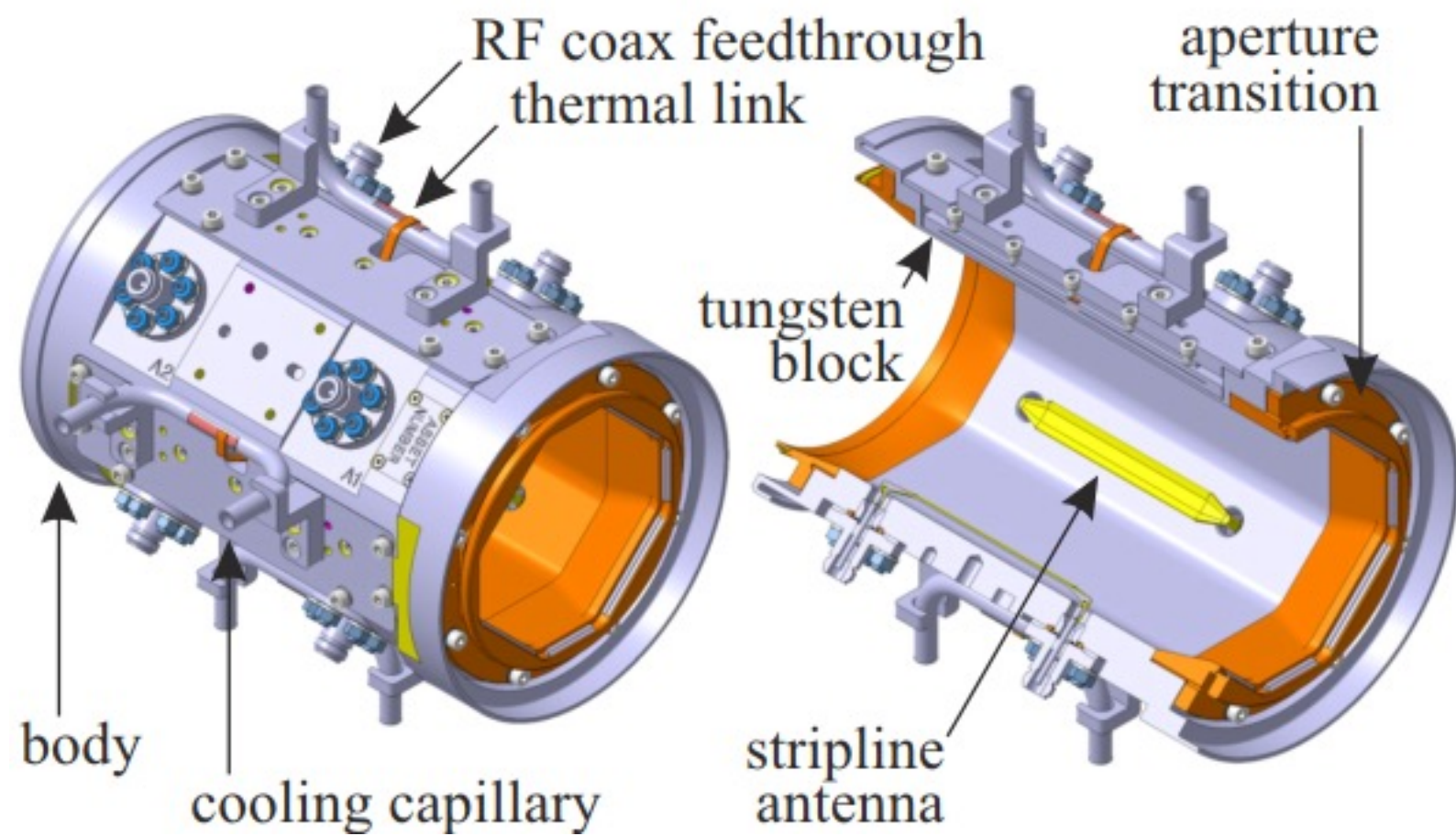
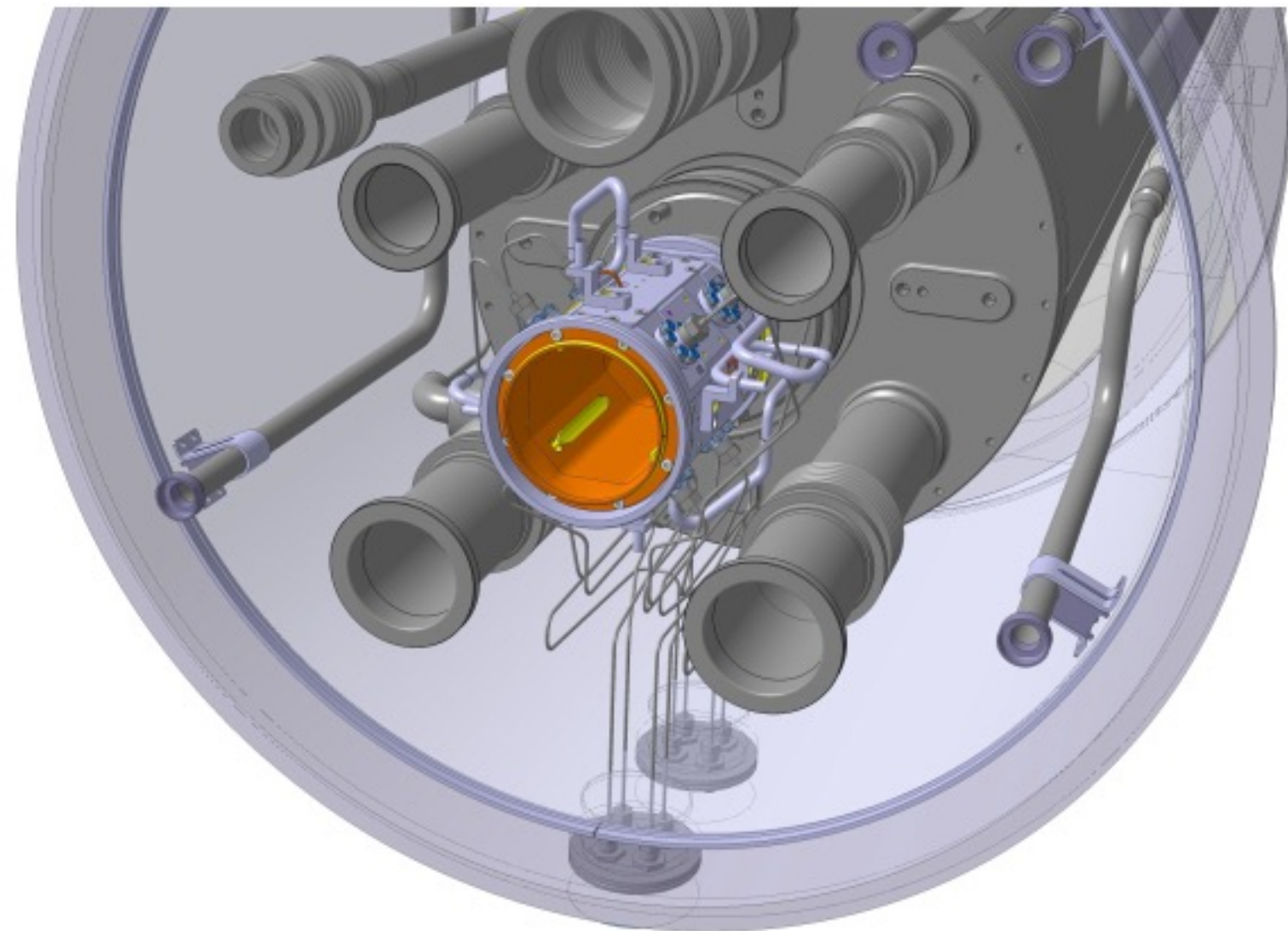

Coated pre-series body at CERN

- Stripline pickups sensitive to beam direction for the cryogenic combined beam sections
- New electronics on state-of-the-art RFSoc chip
- Counter beam compensation algorithm applied to two-beam waveforms:

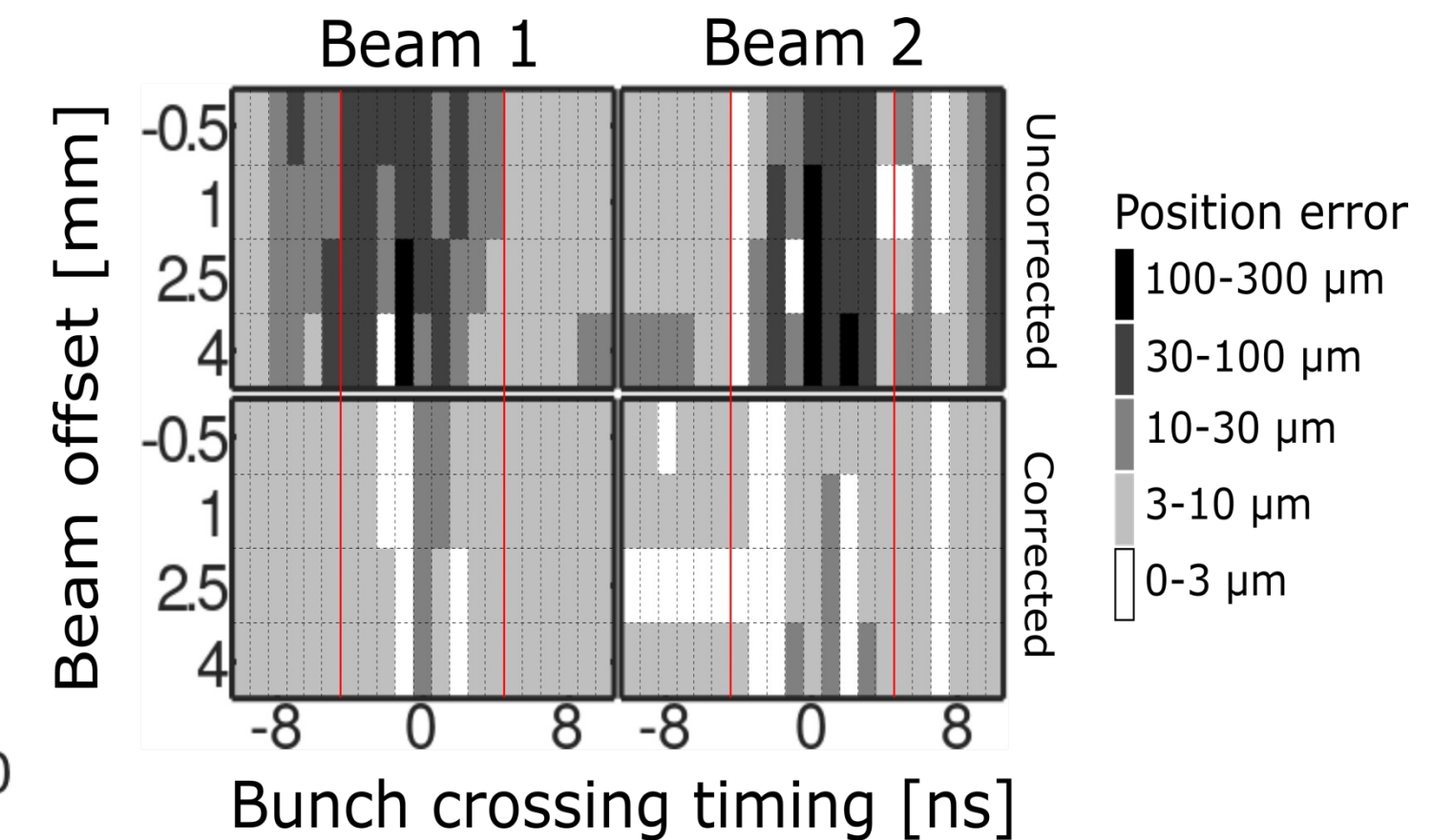
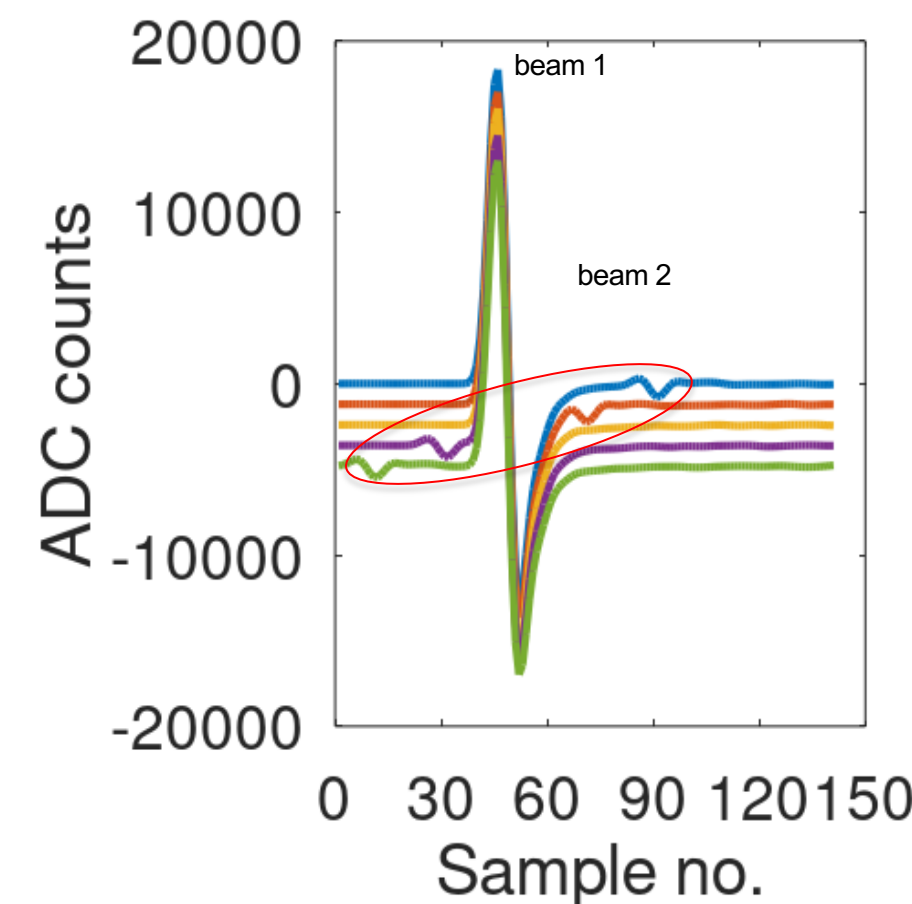

Details in IPAC23: [THPL089](#) & [THPL119](#)
+ [IBIC20 WEPP12](#) and [IBIC21 MOPP24](#):

HL-LHC Crab Cavity BPMs

- Multi-purpose pick-ups required for Crab Cavity diagnostics, placed at high beta functions and favourable phase advance
- RHUL-CERN responsible for **high-bandwidth BPMs** for direct monitoring of residual crabbing and instabilities
- Stripline BPMs now HLLHC baseline

Elongate HT-like stripline:

Same approach as the LHC HT pick-ups: use the latest stripline BPM design but make the electrode longer (400 mm). BW limited by hybrid.

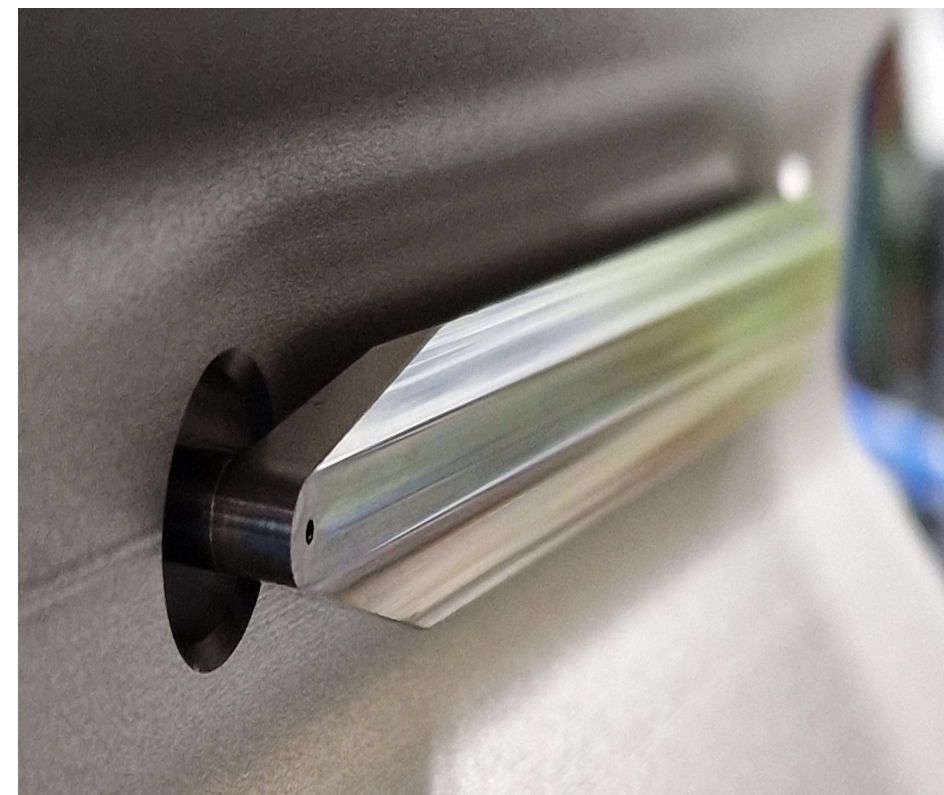
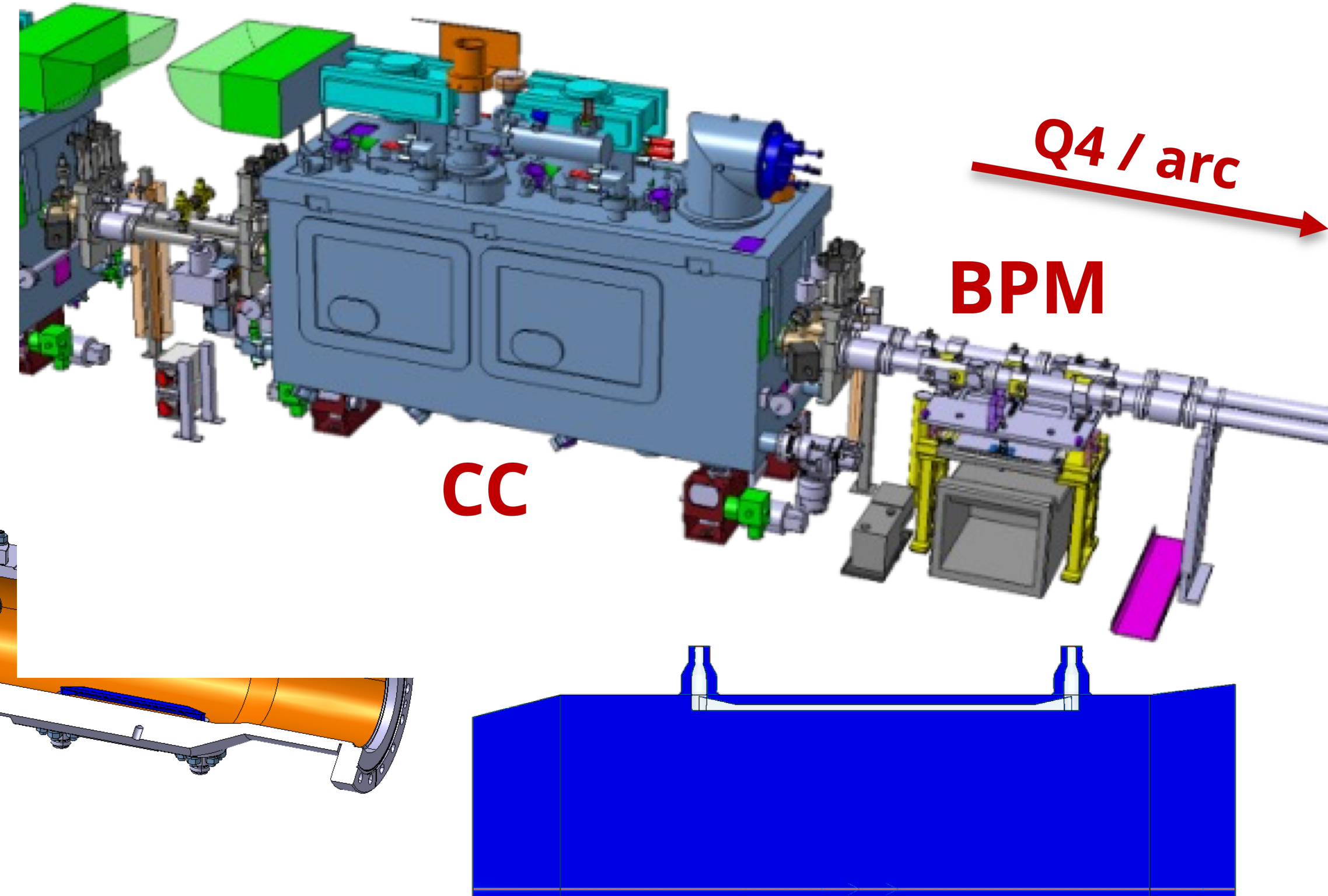
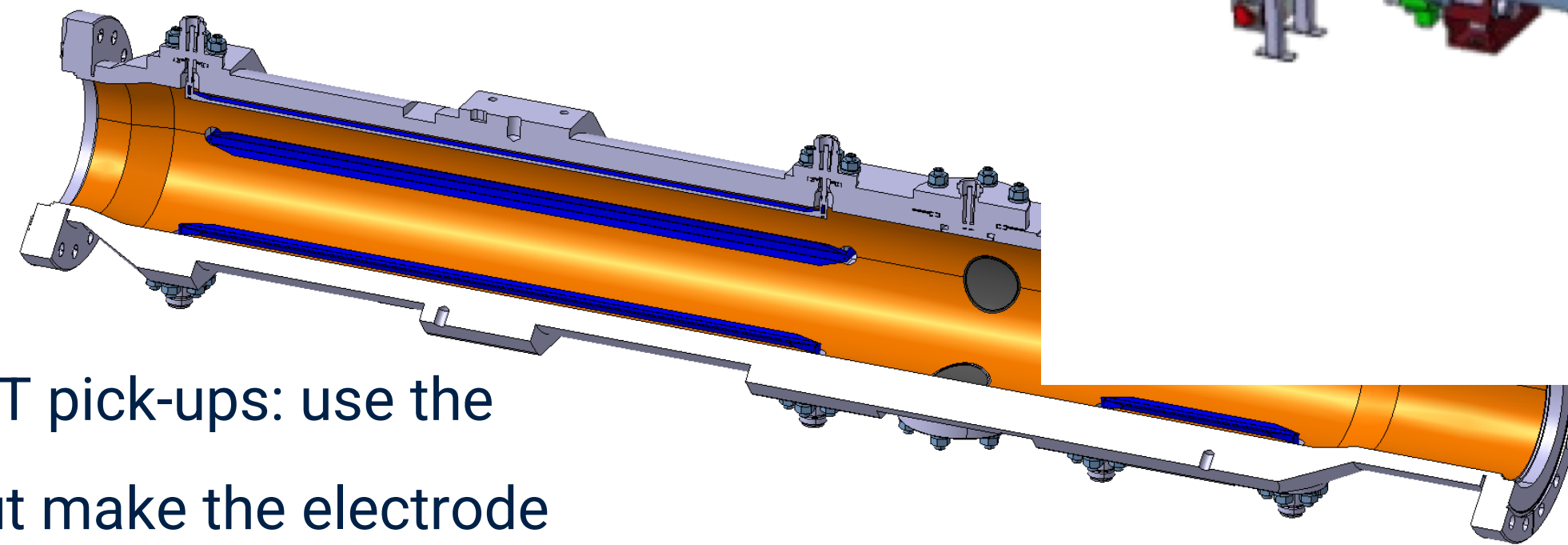

HL-LHC stripline

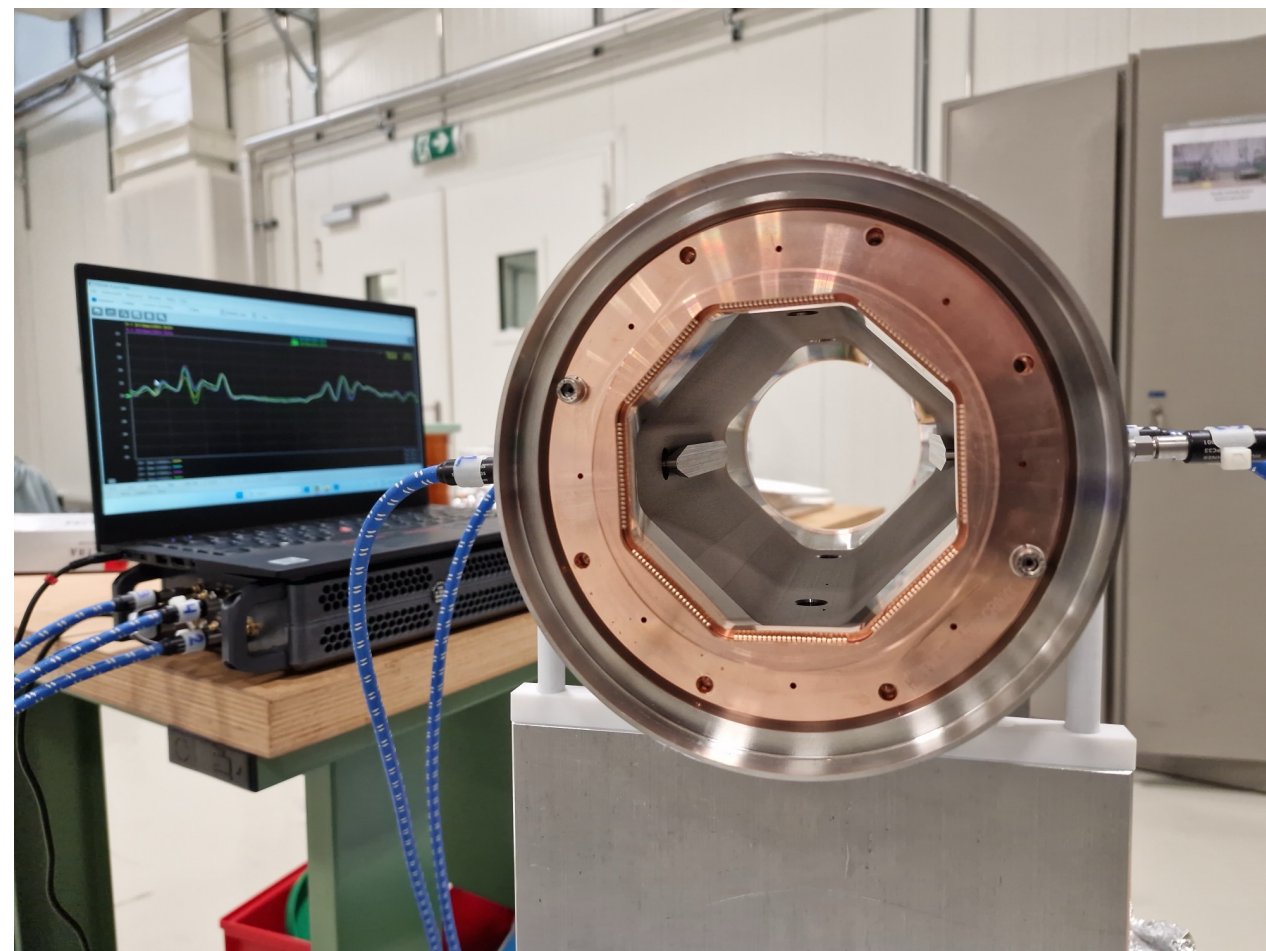

RF lab measurements

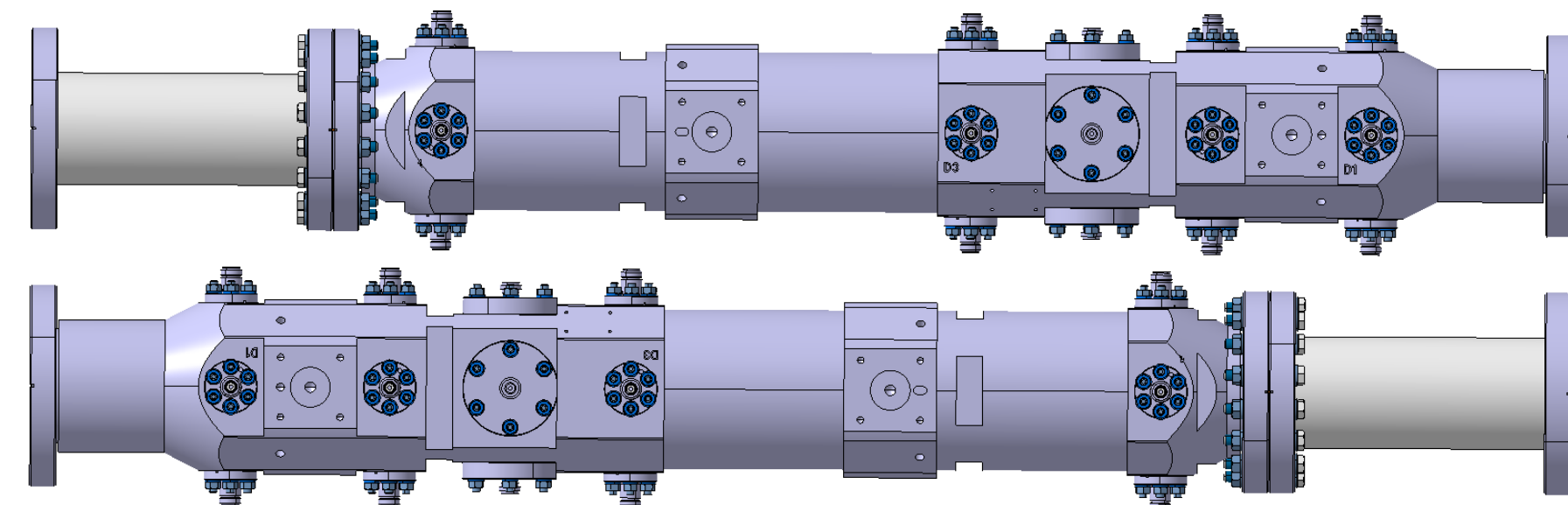

2025 studies with LHC IP4 Head-Tail pickup



- RHUL-CERN PhD student: Giusy Passarelli contributing to design studies with M. Krupa.
- Development of a new procedure for correction of imperfections of the front-end RF electronics
- All existing head-tail monitors, including front-ends, measured and modelled
- Technique validated offline using beam data, further computational optimization possible

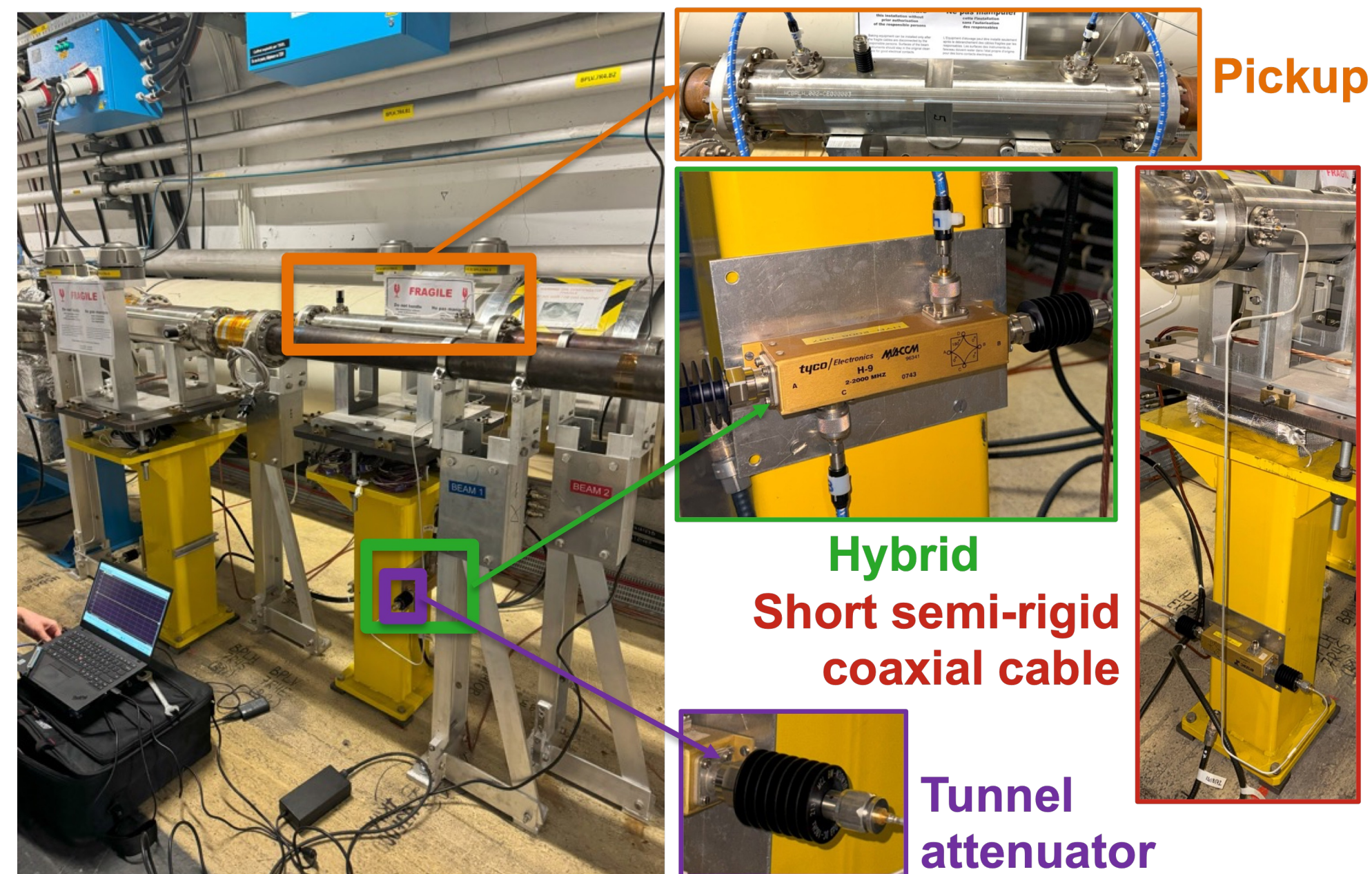
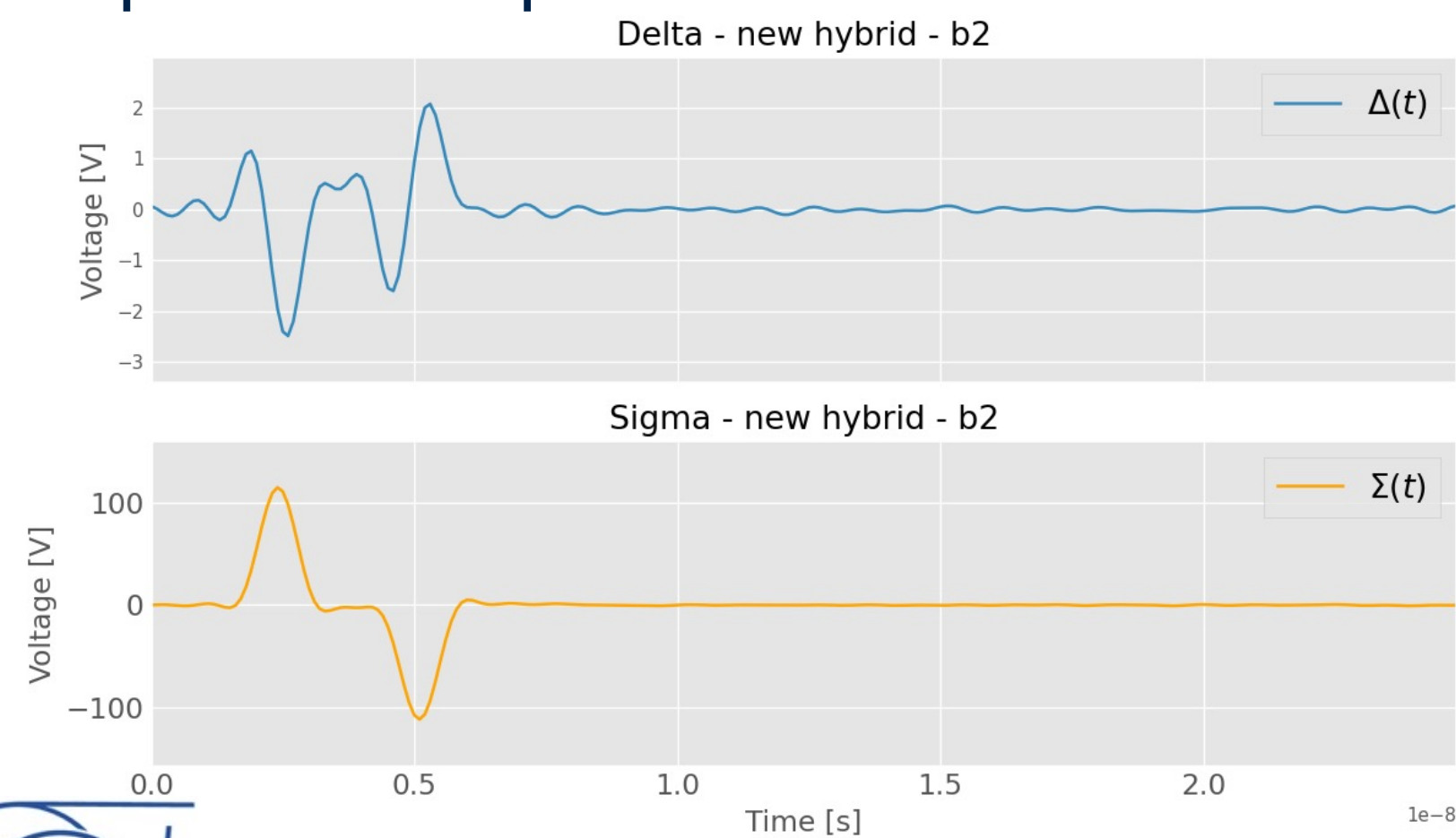
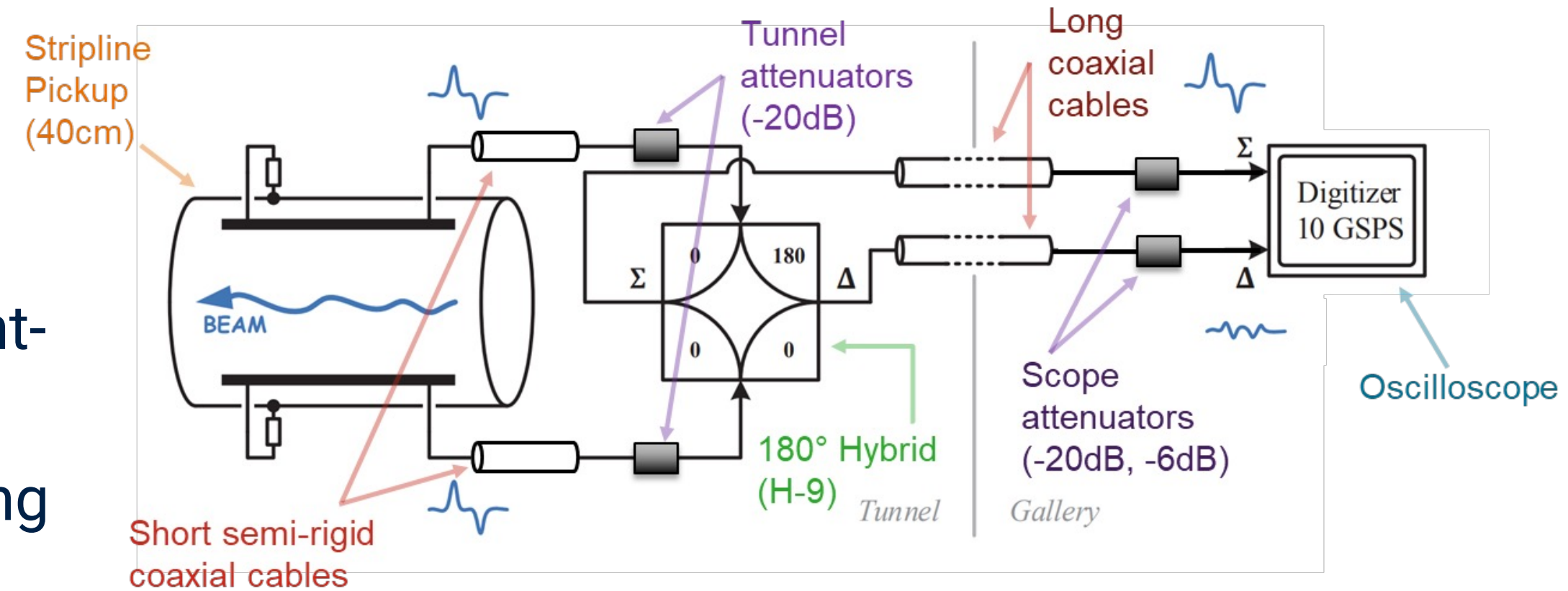

Expected performance

Signal digitizer remains the bottleneck of the system

- Commercial high-end oscilloscopes used currently

New digitizer will be procured as late as possible to leverage (slow) technology progress

- Current technologies do not fully meet the WP13 specification

Electro-optical time-stretching read-out techniques under consideration to replace the traditional RF front-end

- Promising results from **EO Modulator Time Stretch** prototype tests at CERN: see Andreas Schlögelhofer's talk at HL-LHC annual meeting:

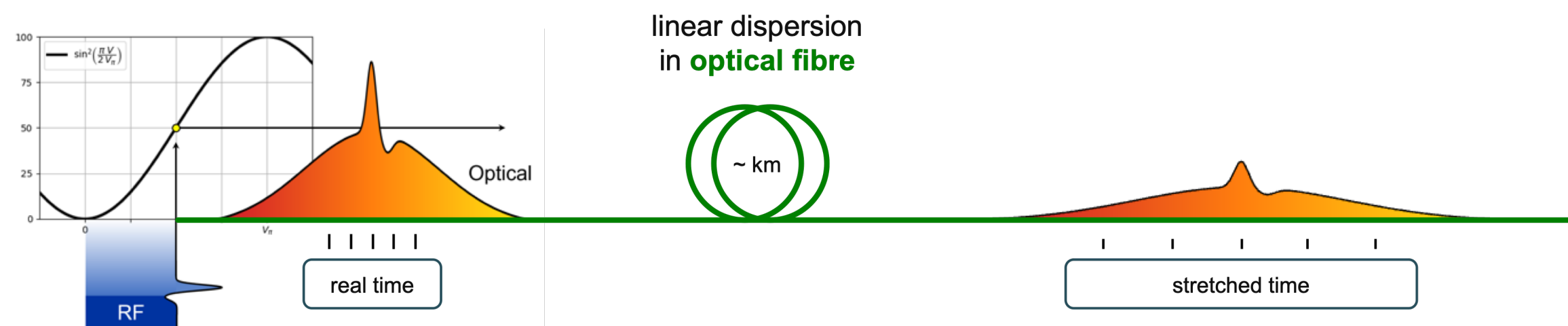
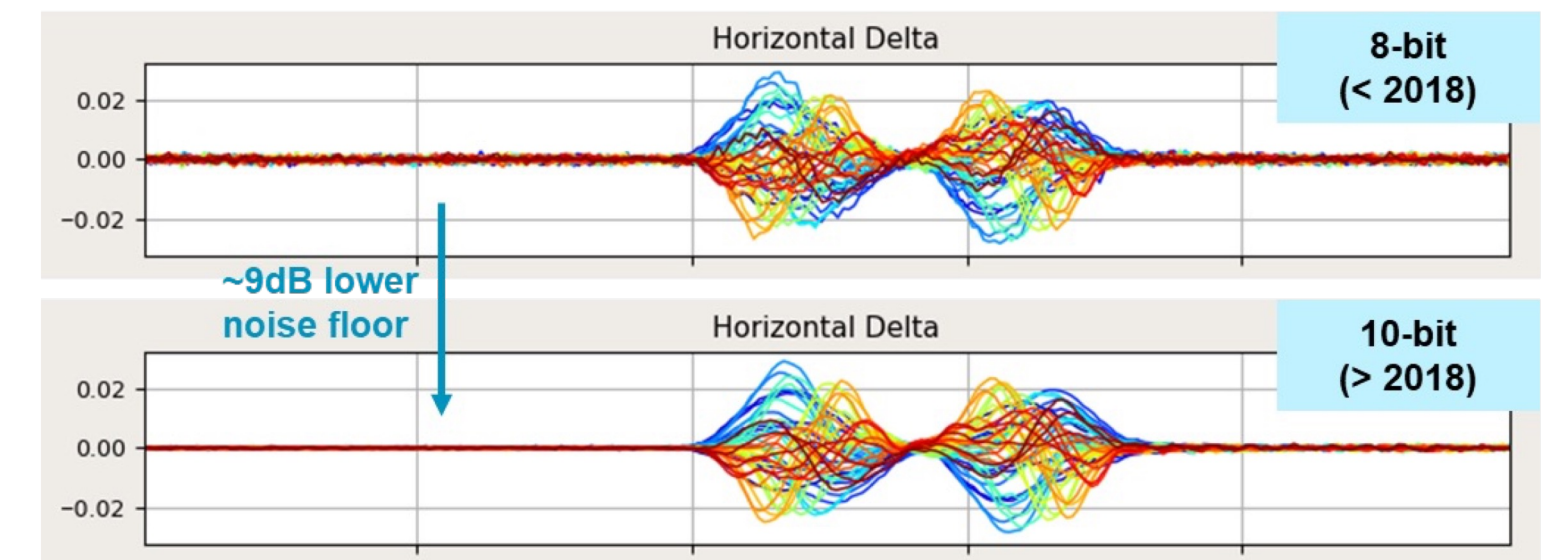
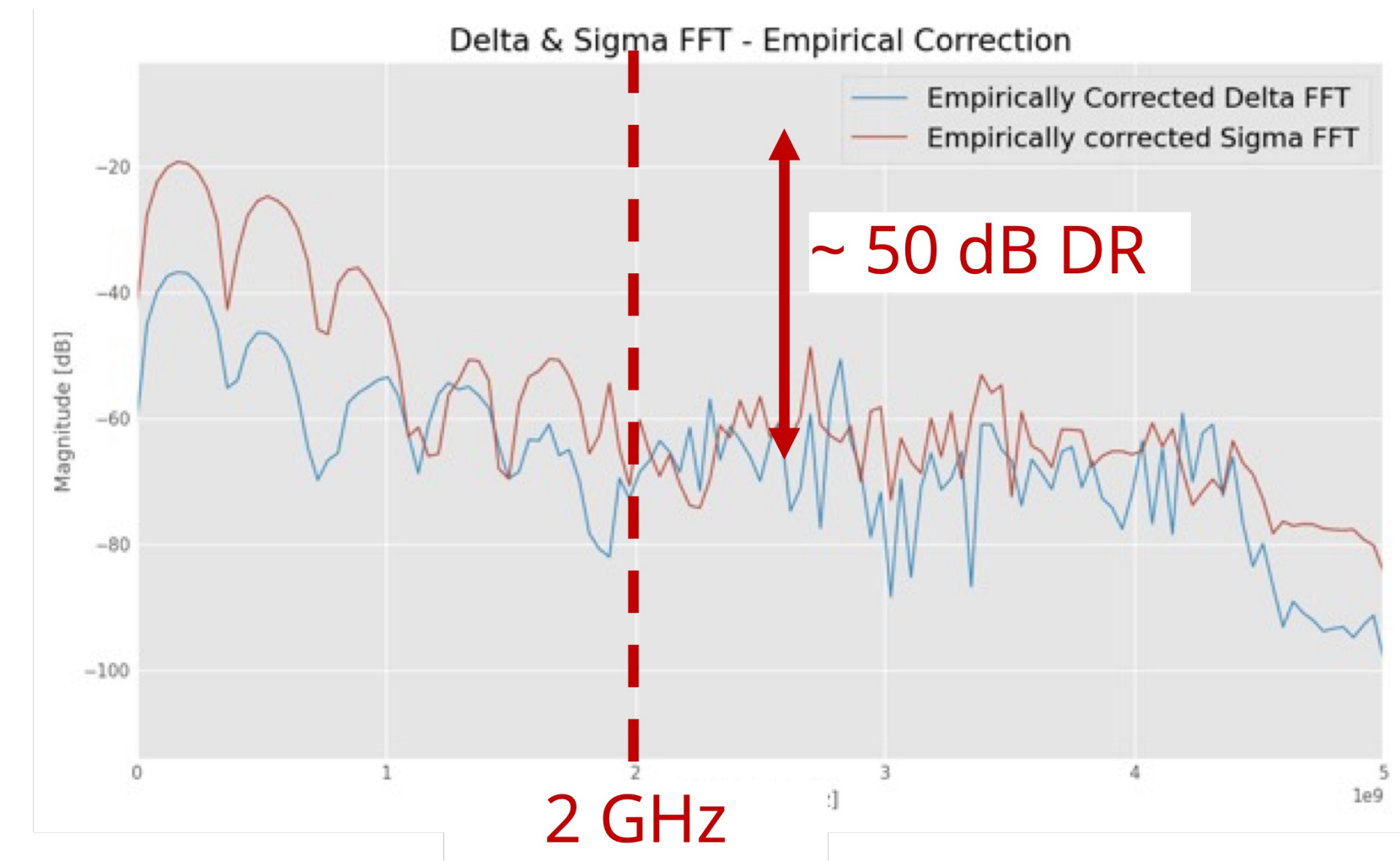

1 radio-over-fibre with EO modulator ✓

2 time stretch ✓

1 2 → EO Modulator Time Stretch (EOMTS)

Digital Σ -signal from electrodes

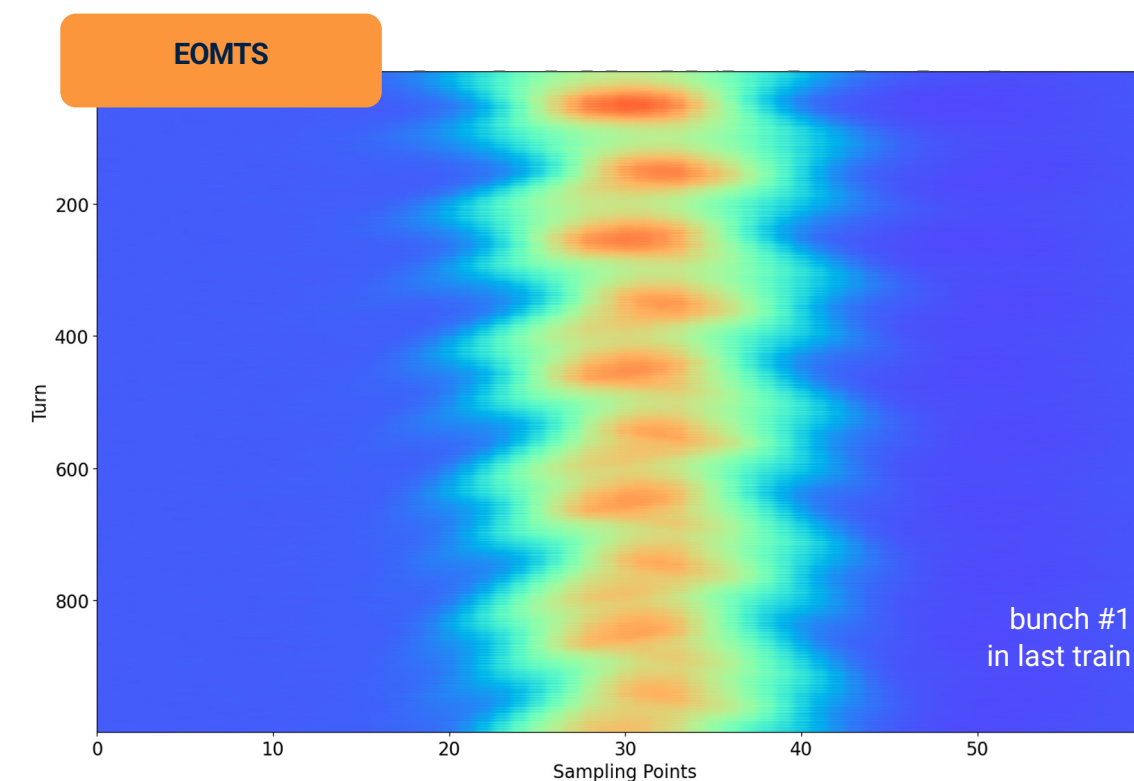

Analog Σ -signal from hybrid

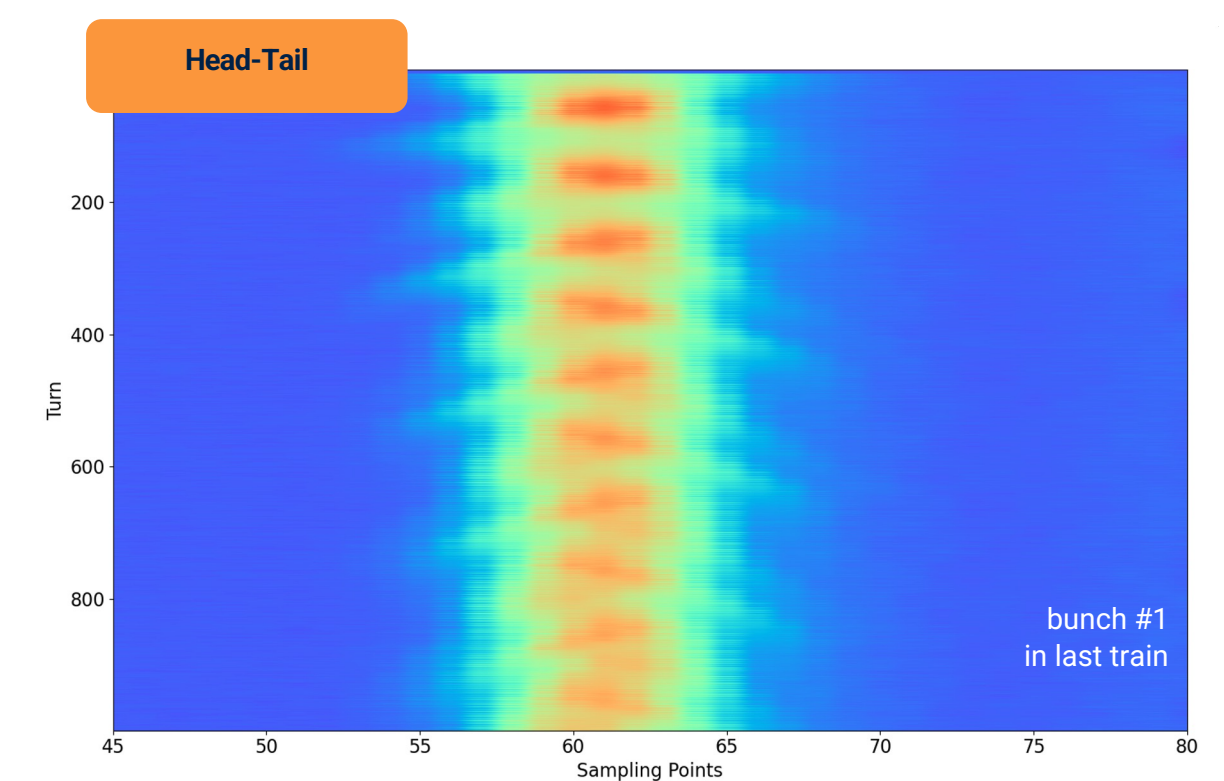

○ alignment on unmodulated laser pulses
→ relative timing between consecutive turns

○ alignment on bunch profiles themselves

Electro-Optic BPM principle

First results published in Nature Scientific Reports:
 Arteche, A. *et al.* First difference mode interferometer demonstration for a high-bandwidth Electro-Optic Beam Position Monitor. *Sci Rep* 15, 43410 (2025). [doi:10.1038/s41598-025-08786-6](https://doi.org/10.1038/s41598-025-08786-6)

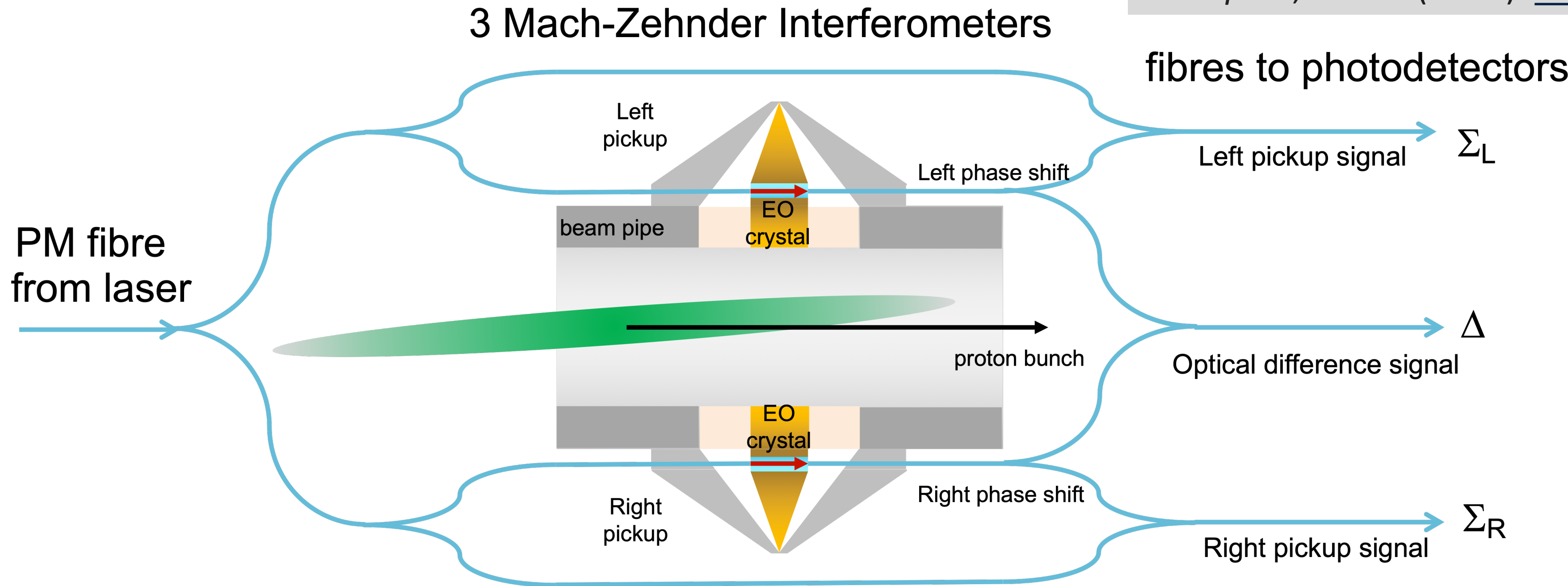

intensity change

$$\Delta n_z = \frac{1}{2} n_z^3 r_{33} E_z$$

n = Refractive index
 r₃₃ = Electro-optic coefficient (33 pm/V)
 E = Electric field

$$\phi(t) = \frac{2\pi}{\lambda} n_e l + \frac{\pi}{\lambda} n_e^3 r_{33} l E_{az}(t)$$

$\Sigma = \Sigma_L + \Sigma_R$
 position = Δ/Σ

Encode the time-varying bunch signal onto a laser beam using an electro-optic crystal in the pickup:

The electric-field of the passing bunch modulates the refractive index that induces a linear phase shift in light passing through the crystal by the Pockels effect.

A fibre-coupled Mach-Zehnder interferometer around the crystal transforms the phase shift into an intensity modulation, which is measured by a fibre-coupled fast photodetector.

Electro-Optic BPM development

At the time of the technology review in January 2025:

- **EO-BPM signals follow the fast evolution** of SPS bunch during injection: sensitive to both longitudinal shape and transverse position.
- **Known difference between left and right EO pickups** results in mixture of sum and difference signals in the interferometer difference signal. **Combination of HT sum and difference signals reproduces the EO signal.**

doi:10.18429/JACoW-IBIC2024-TUP46

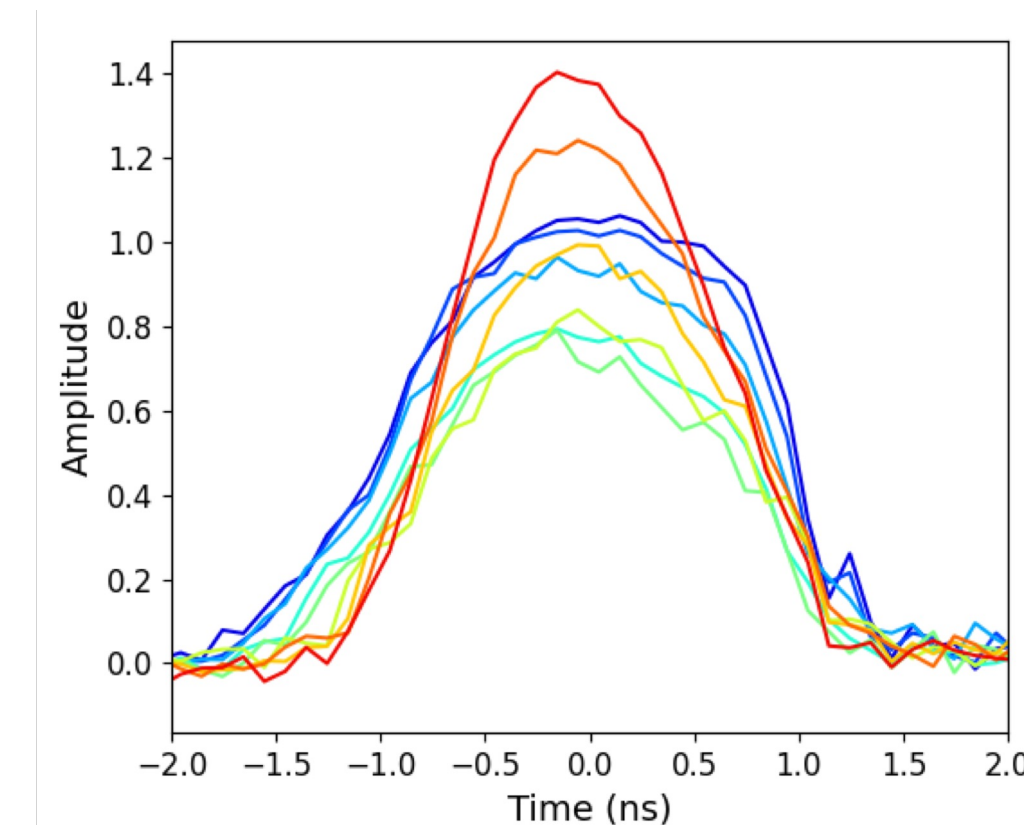

(a) EO-BPM

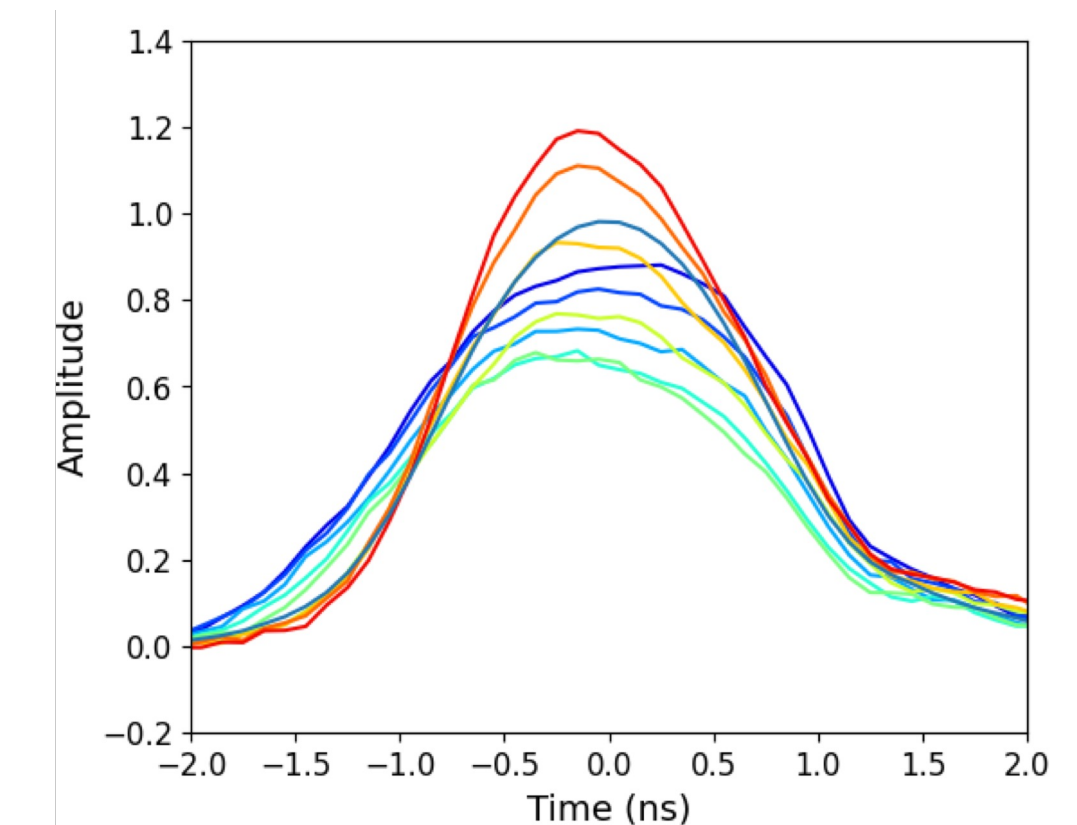

(d) Combined HT sum & diff.

EOBPM developments in 2025/26:

- **Adjustable pick-up** designed to tune and set the sensitivity of pick-up to beam field signal, installed in June 2025 Technical Stop. --> Max Bosman, IBIC2025
- Improved operations with EO-modulator **phase control** in all three interferometers + new IQ technique --> Dan Harryman, IBIC 2025
- **Fibre splitter tree** reconfiguration in January 2026 YETS, to correct fibre lengths for timing mis-match, and test IQ technique in situ.

Signal response sensitive to pickup assembly tolerances:

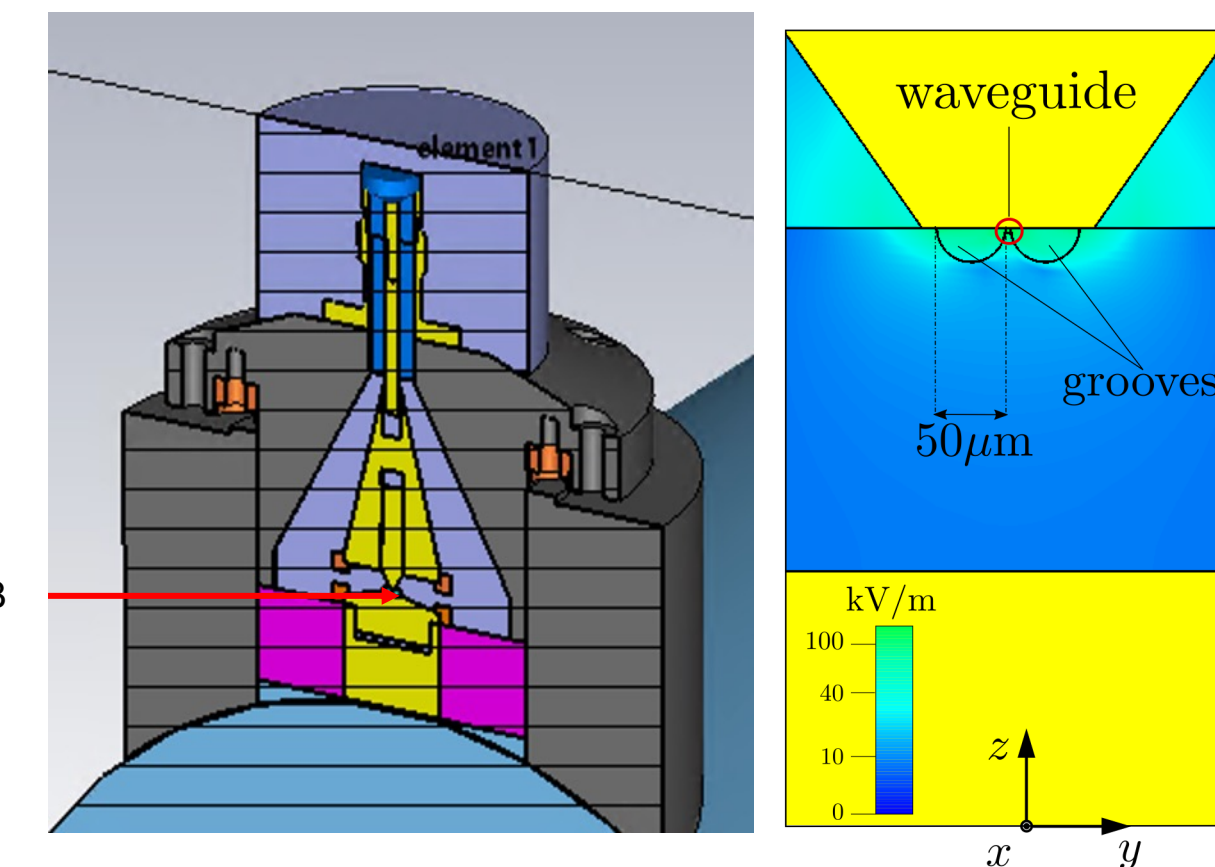
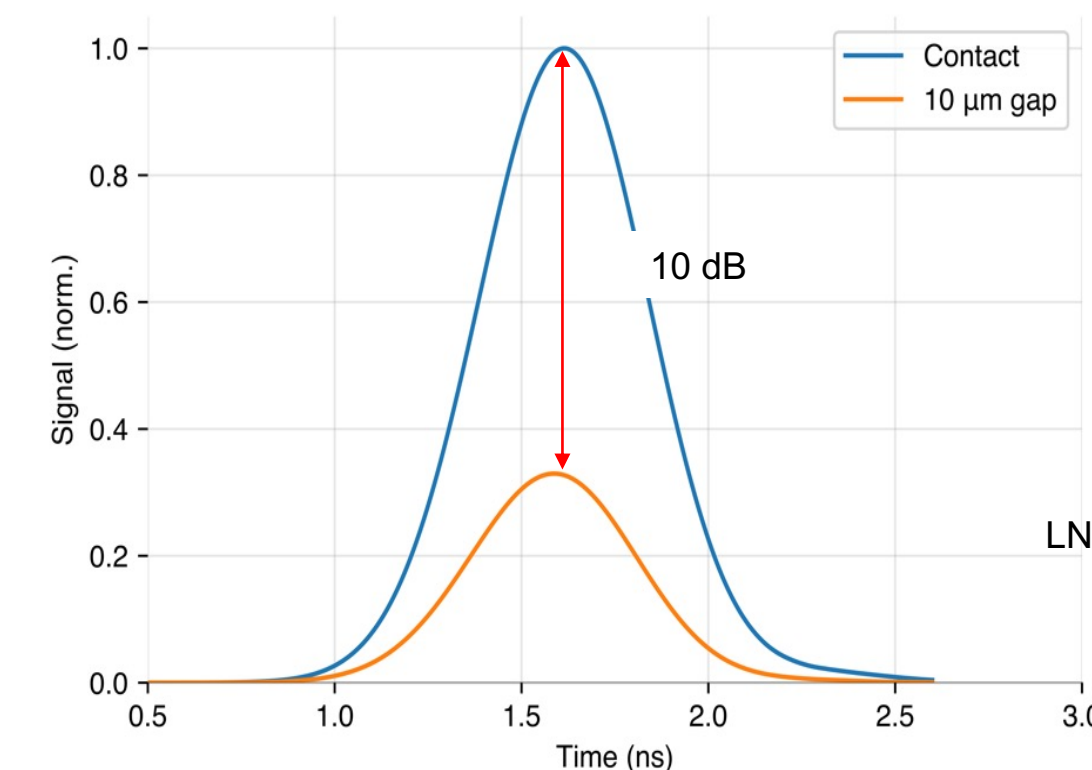

EOBPM: Adjustable pickups, balanced in situ:

New adjustable EO pick-up design features:

- Cylindrical housing with **improved impedance matching**
- **Differential micrometer** to set position of top electrode
- **Retractable wire** to inject calibration signals to beam electrode:

10 V pulse injected into both pickups separately, and at the same time, and micrometers adjusted to balance signal response:

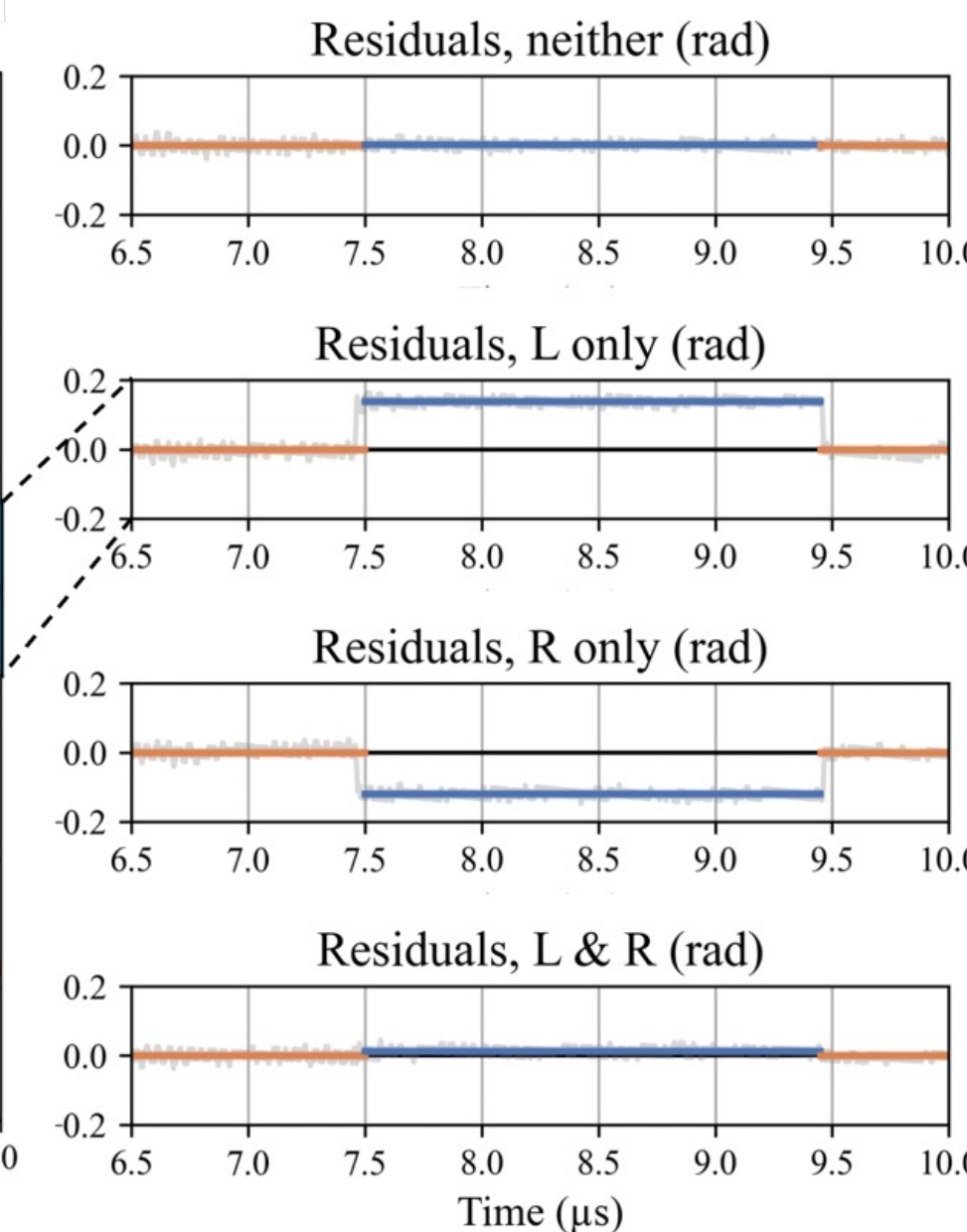
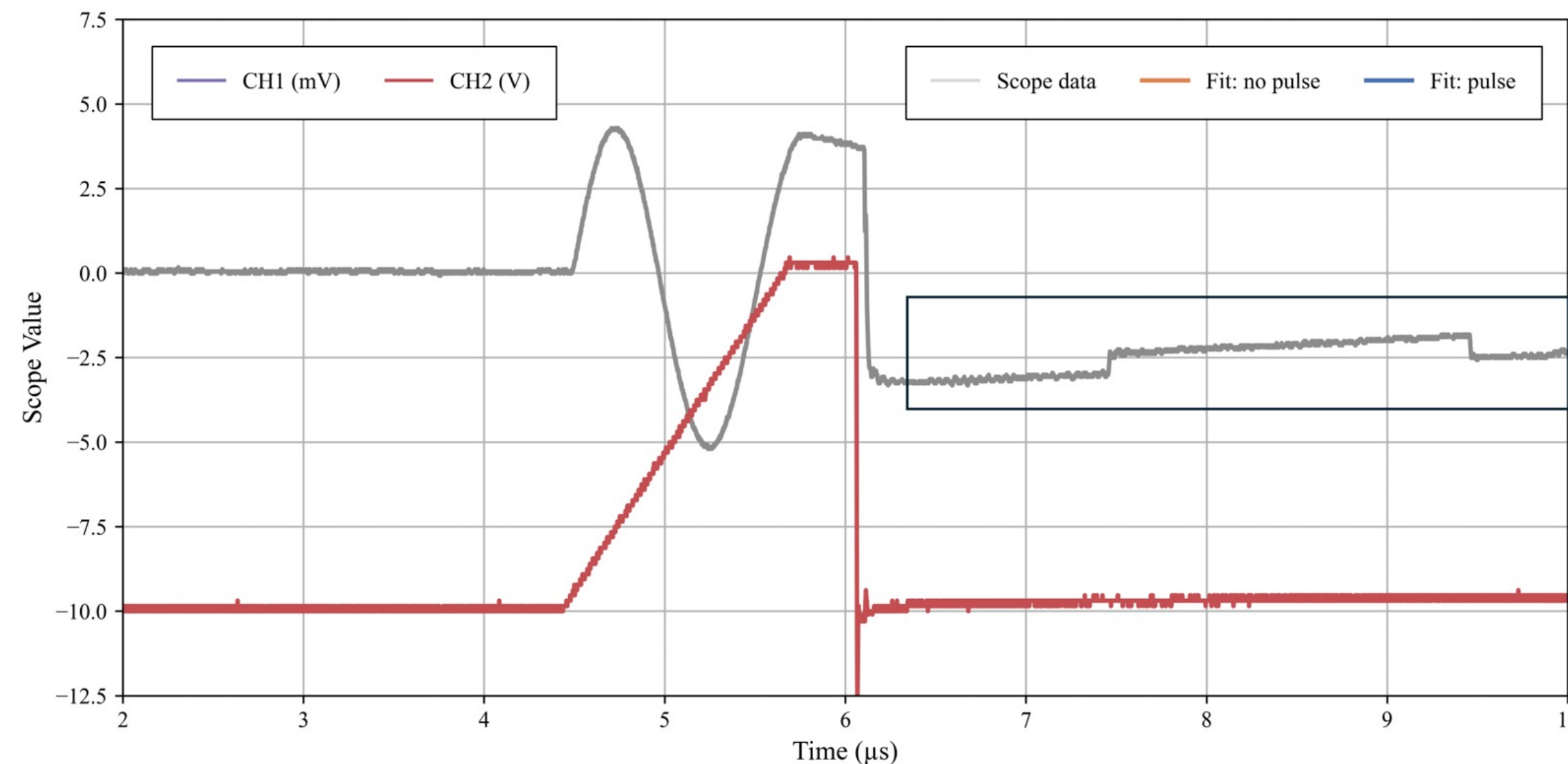
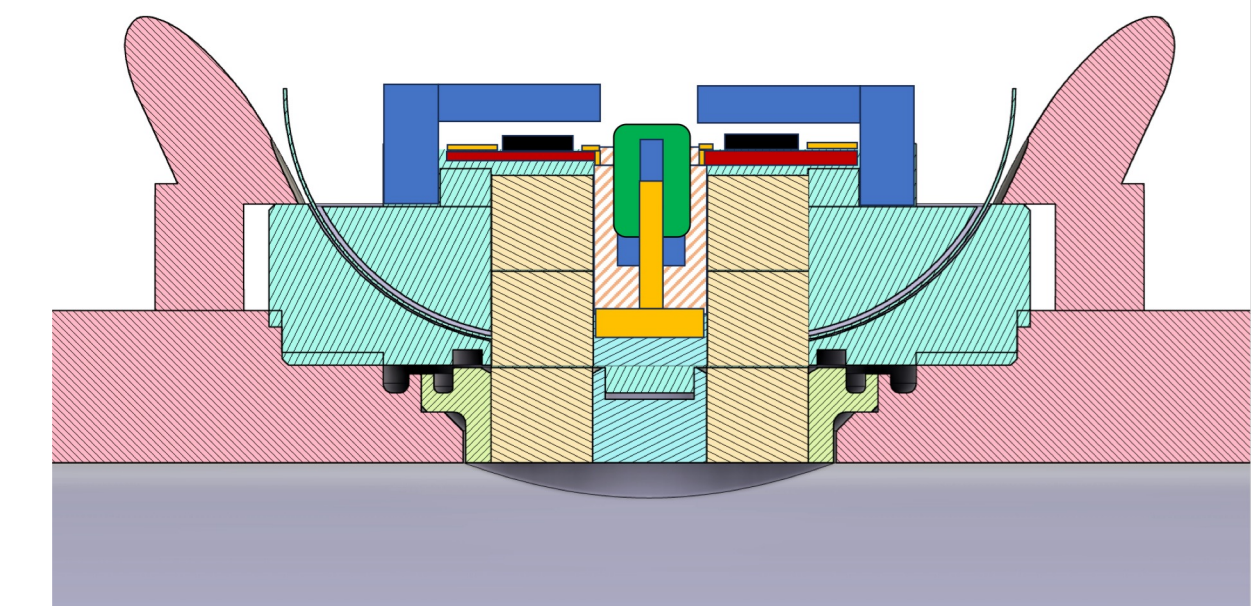
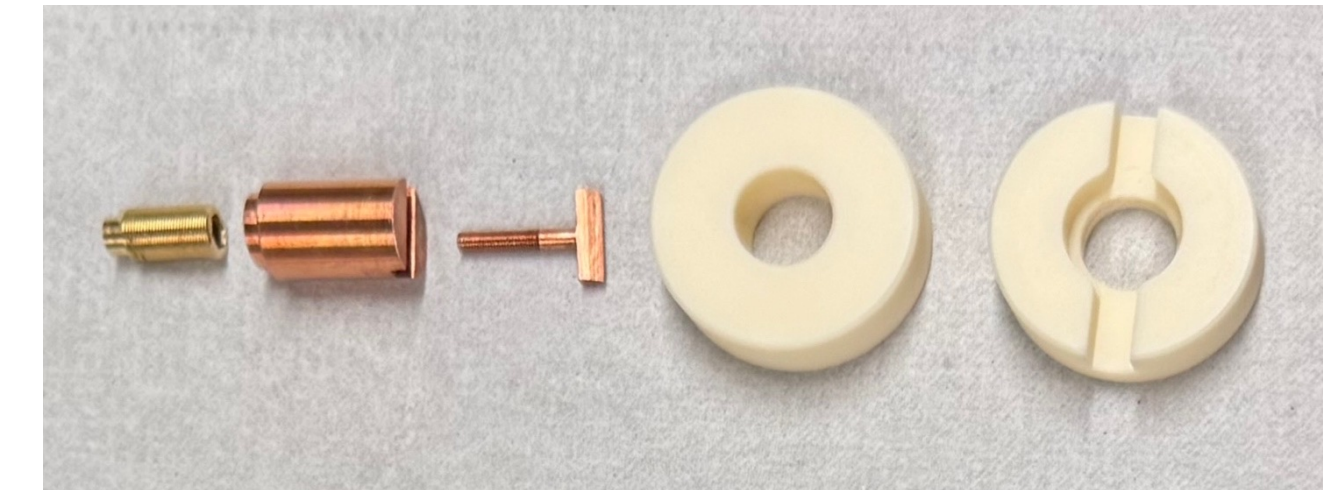
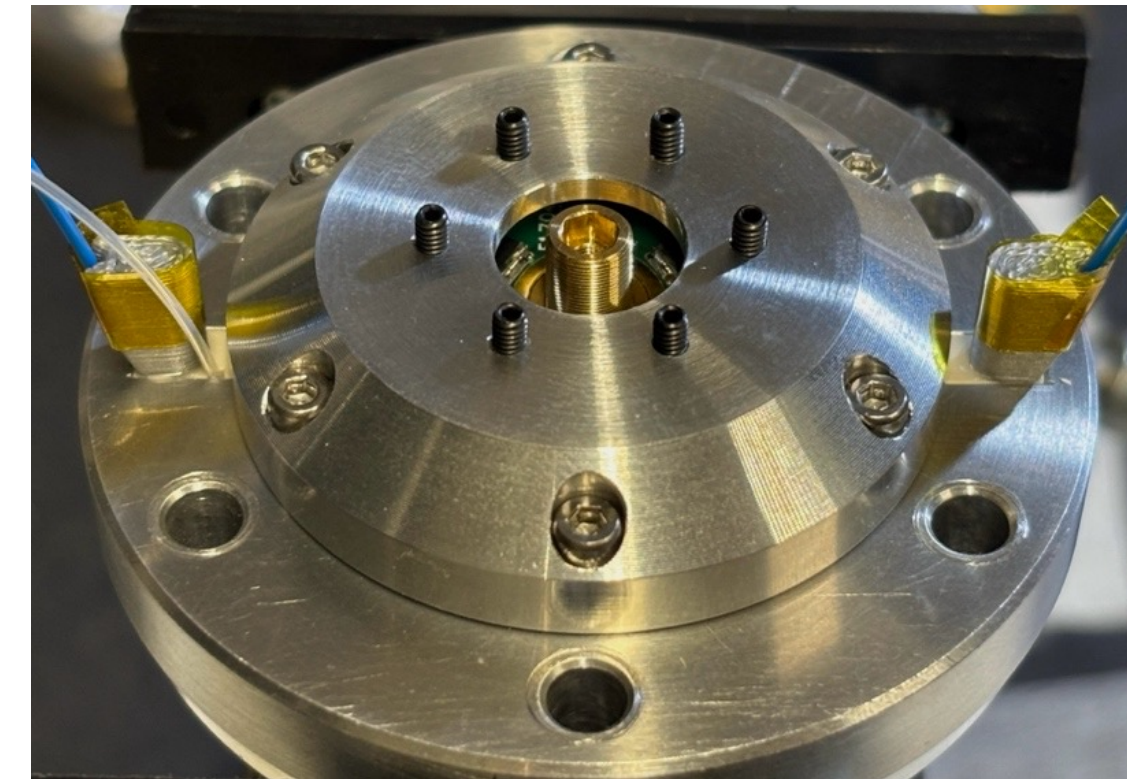

June 2025 installation of new adjustable EO pickups

EOBPM: balanced pickups, with phase control

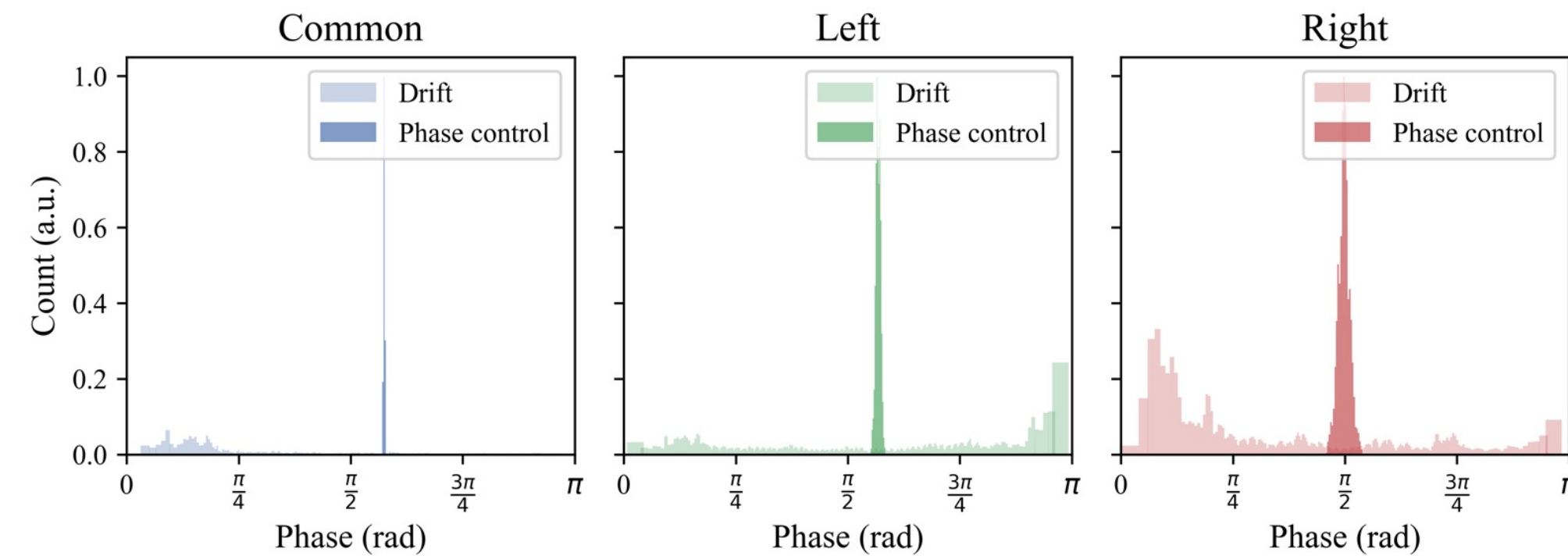
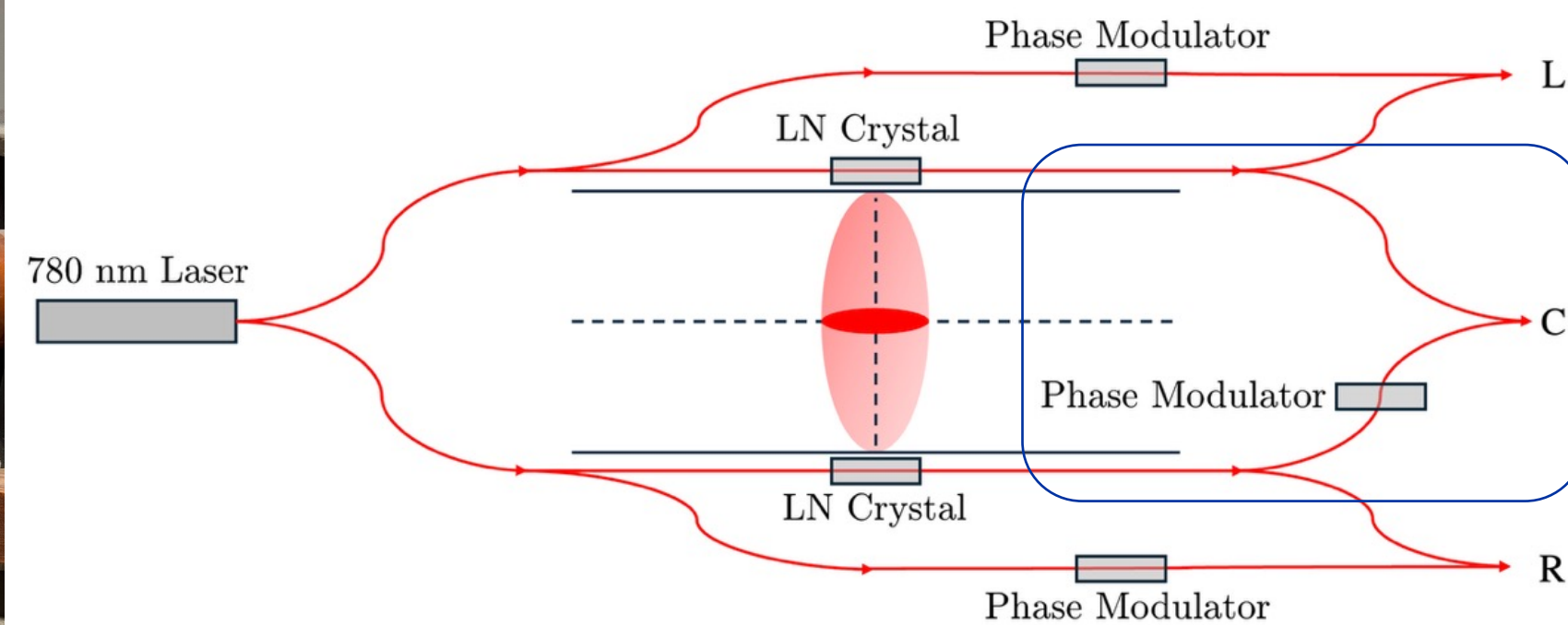
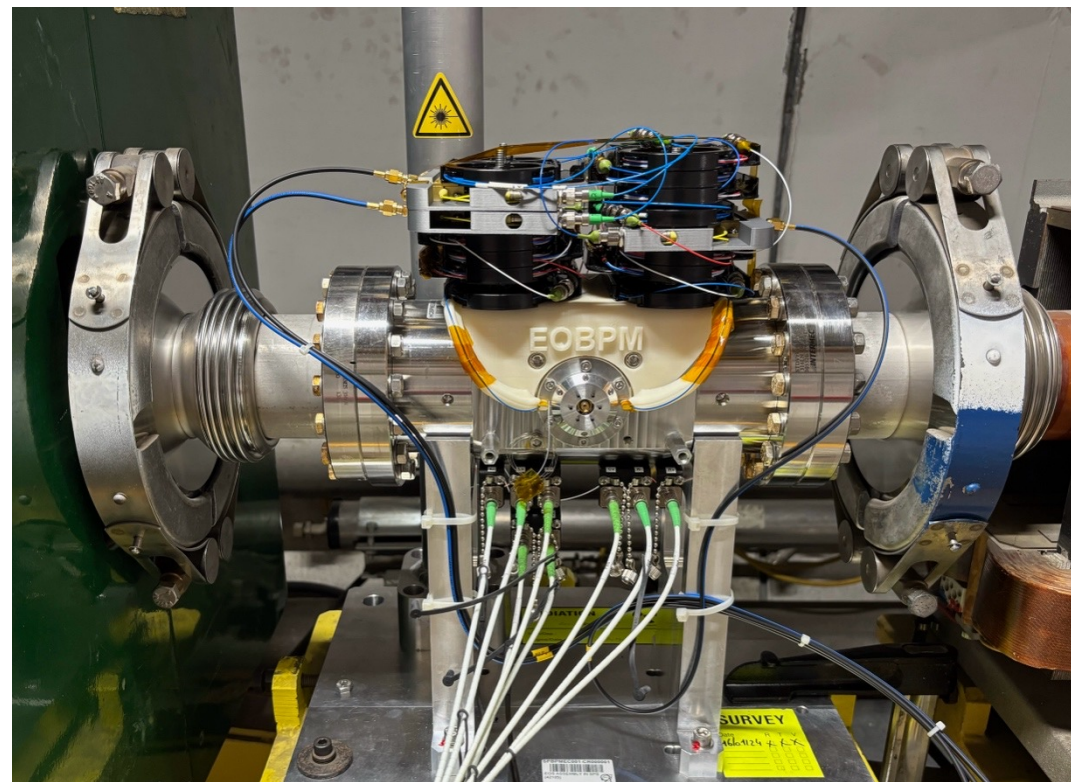

Addition of 3 phase modulators enables smooth control of interferometer phase:

For the first time, signal seen simultaneously on all three modes.

Further adjustments in September 2025: common mode more balanced, side modes stronger.

Common mode here shows timing mismatch in optical difference signal, due to fibre length mis-match: corrected in YETS, Jan 2026

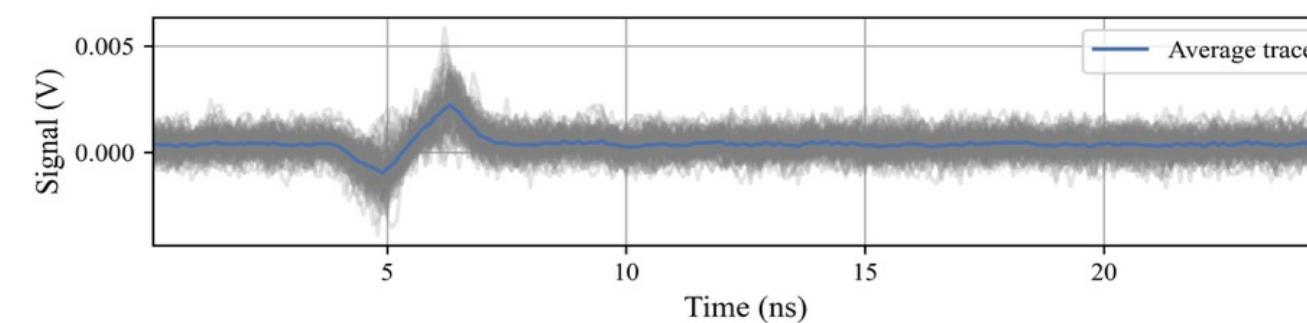

(a) Common mode.

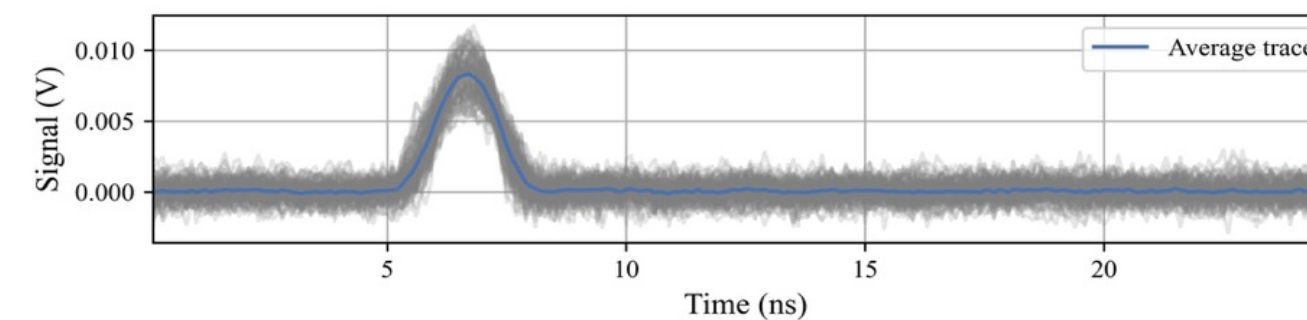

(b) Left mode.

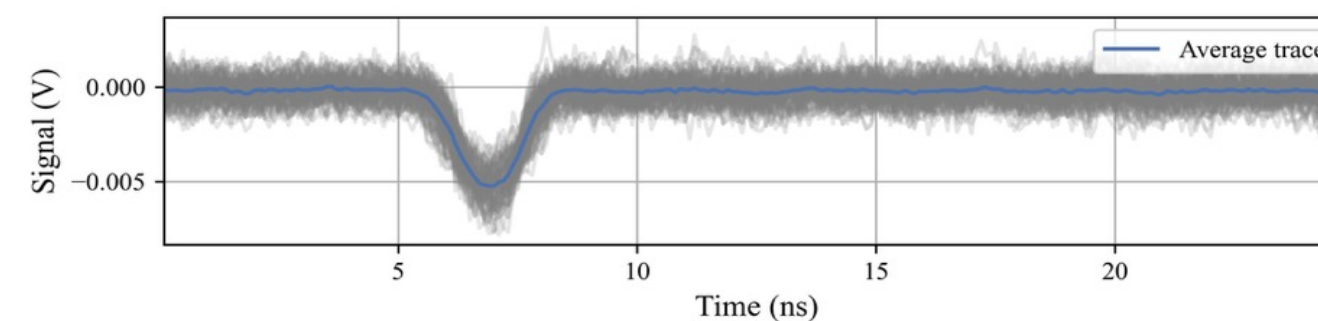

(c) Right mode.

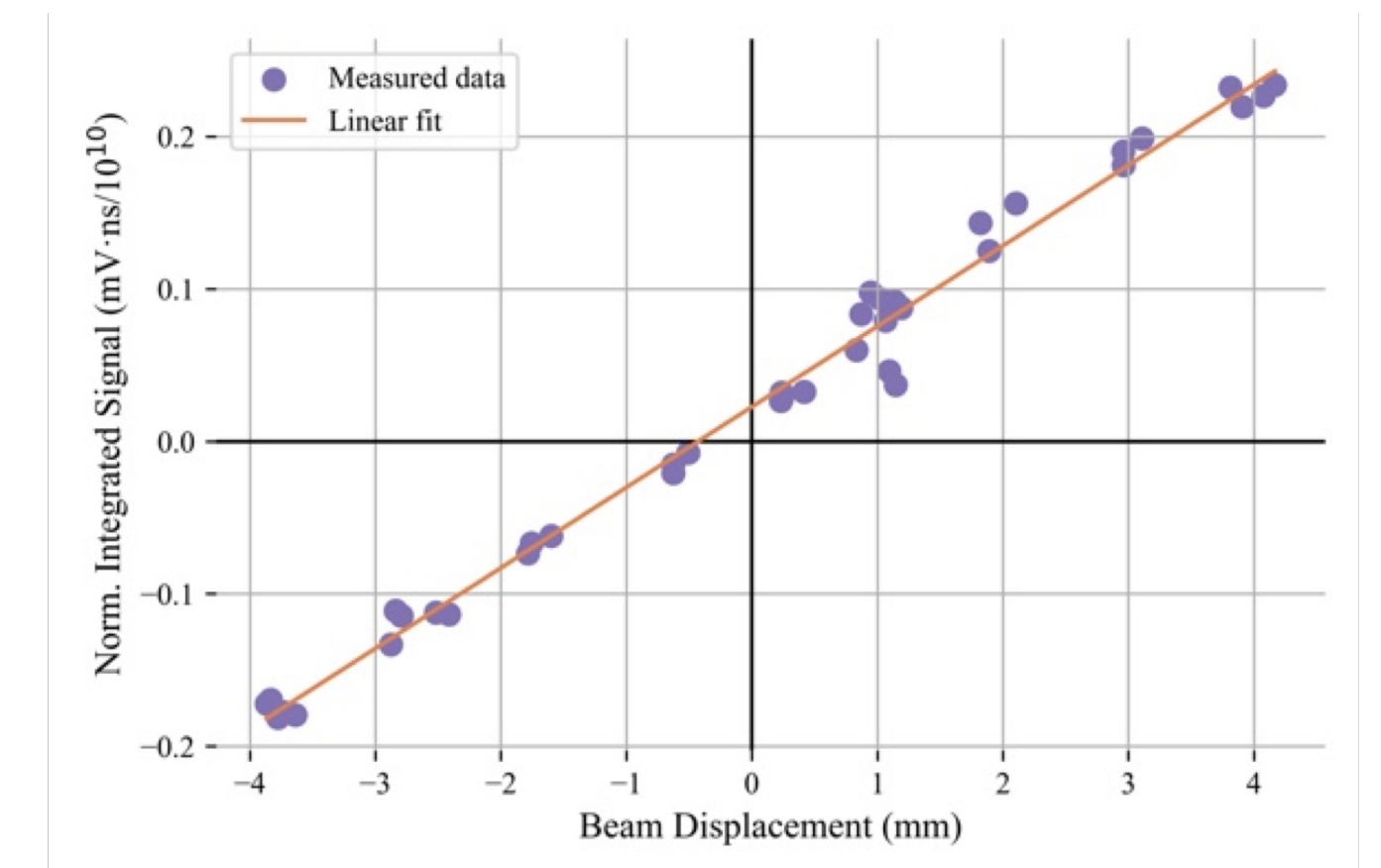

(b) Time integrated signal of adjustable button for various physical beam displacements, after adjustment and using a RXM10CF photodetector; offset is 0.43 mm.

Max Bosman's thesis analysis (preliminary): shows much improved absolute offset

EO Team: A. Arteché, M. Bosman, D. Harryman, S. Gibson, T Levens, T. Lefevre

HL-LHC collimation challenges:

Björn Lindström,
L. Bertolozzi et al

- HL-LHC beam intensity and brightness produces **significant challenges**
 - Protons per bunch: $1.15e11$ (design) \rightarrow $1.6e11$ (now) \rightarrow $2.2e11$ (HL)
- **Impedance** scales with bunch charge and can cause **beam instabilities**:
 - Image charges induced, act back on beam
 - \rightarrow instabilities \rightarrow increased octupoles \rightarrow reduced beam lifetime
 - Collimators main source of impedance
- **Collimator leakage** (absolute) scales with beam intensity
 - \rightarrow increased quench risk, in IR7 DS
 - Mitigation with TCLDs collimators installed between 11T dipoles was de-scoped
- Limitations mainly from Betatron Collimation (IR7)

Change of IR7 Optics mitigates both!

Optics Design

Björn Lindström,
L. Bertolozzi et al

- Goals:
 - (1) Large beam size (betx/bety) at primary collimators – **cleaning, impedance**
 - (2) Small betx at secondary collimators and absorbers – **cleaning, impedance**
 - (3) Increase single-pass dispersion – **cleaning**
 - (4) Small beta function in orthogonal plane of collimators – **impedance**

Final optics for 2025/2026 LHC cycle:

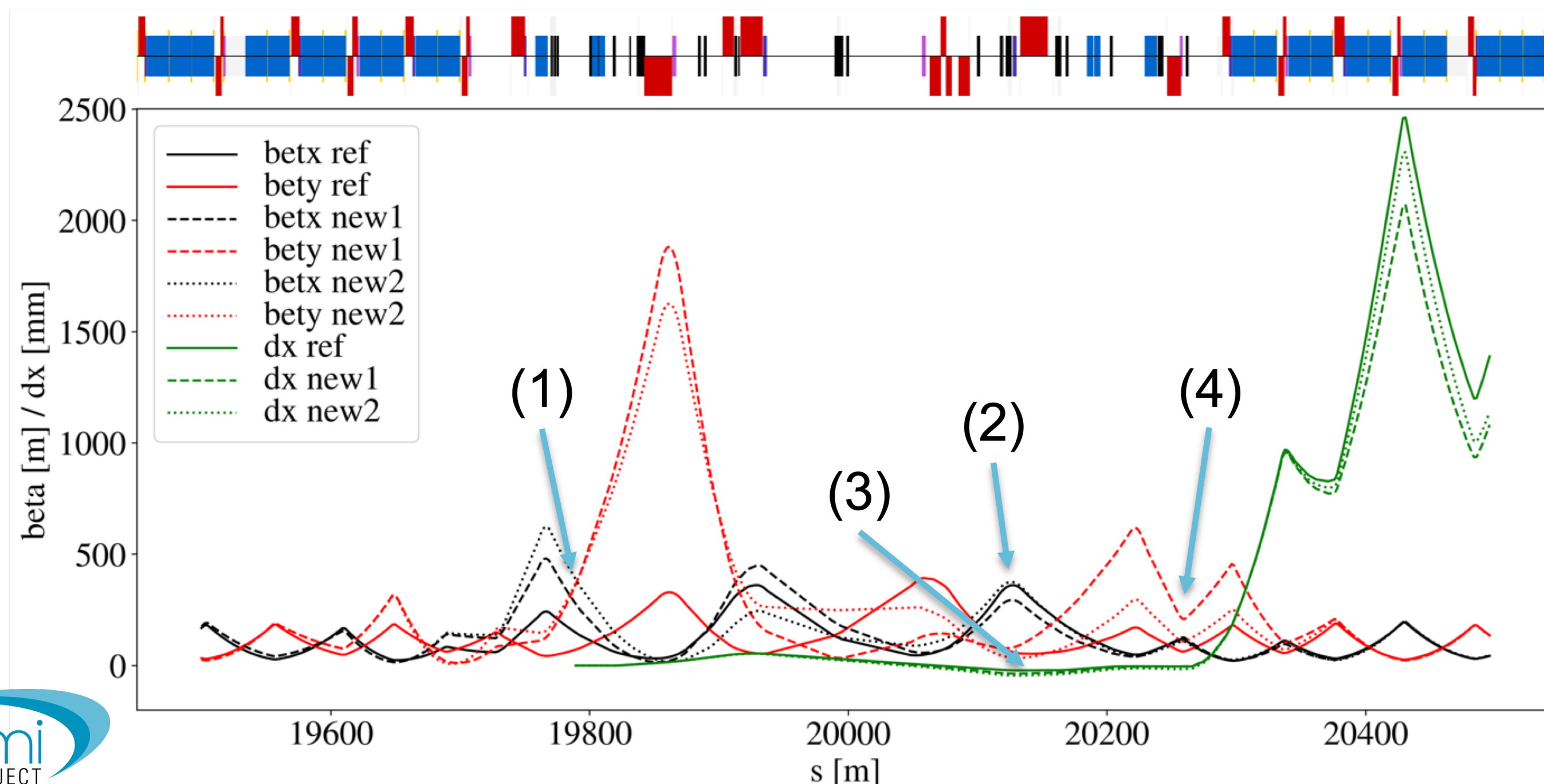
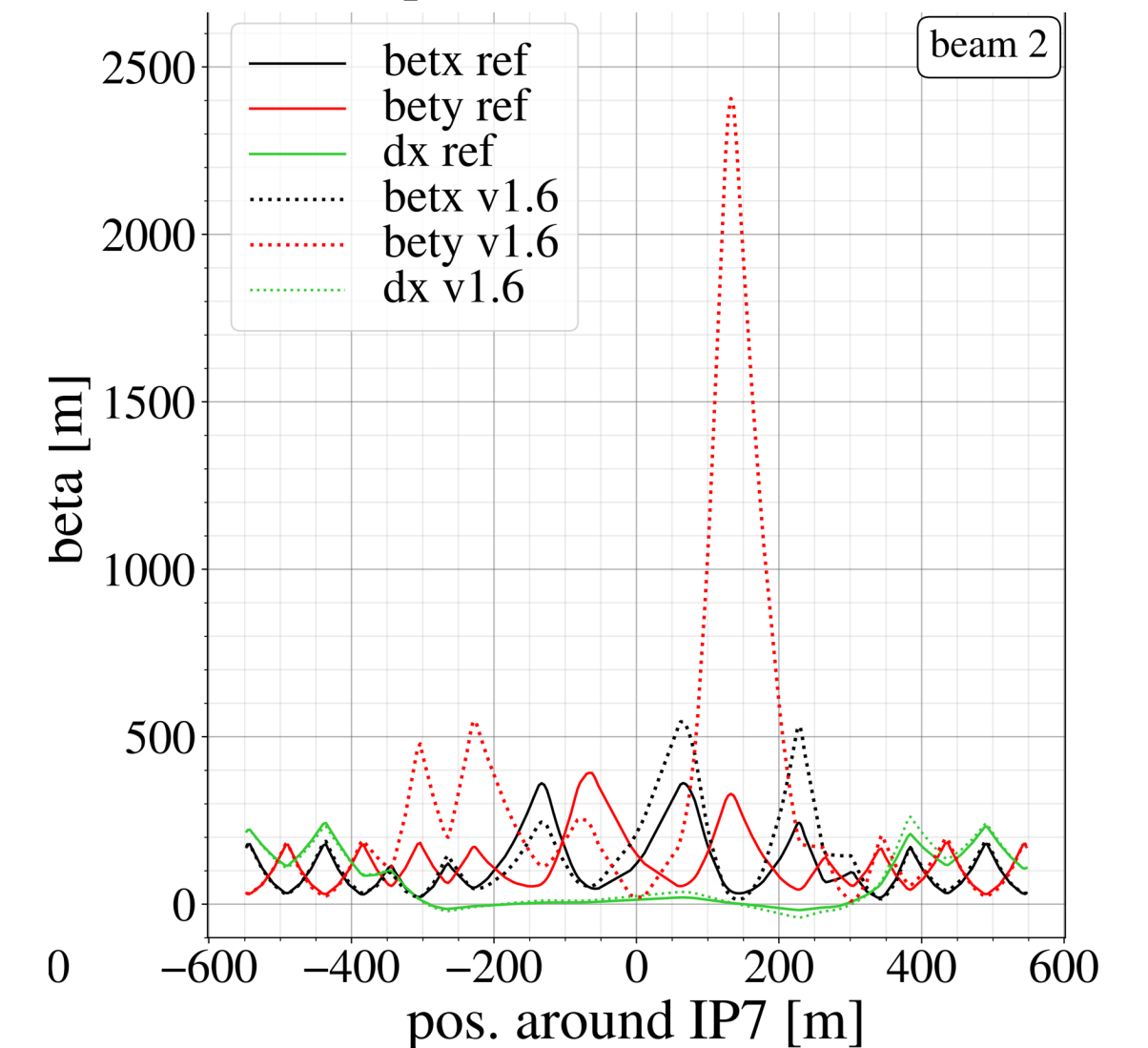
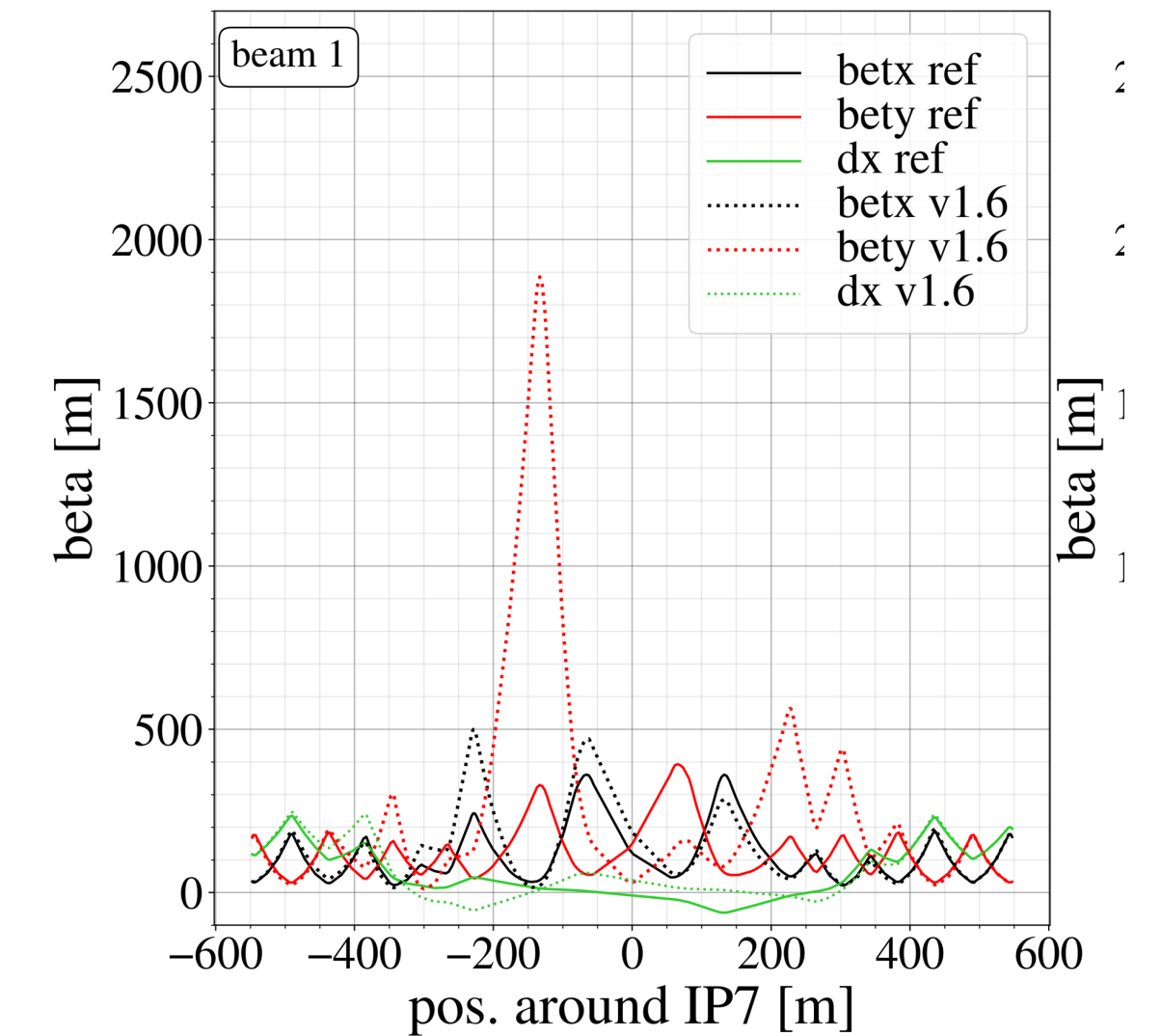

Aperture

- Large beta function and dispersion
→ **Not enough aperture** at injection energy
- Need optics in place before flat top:

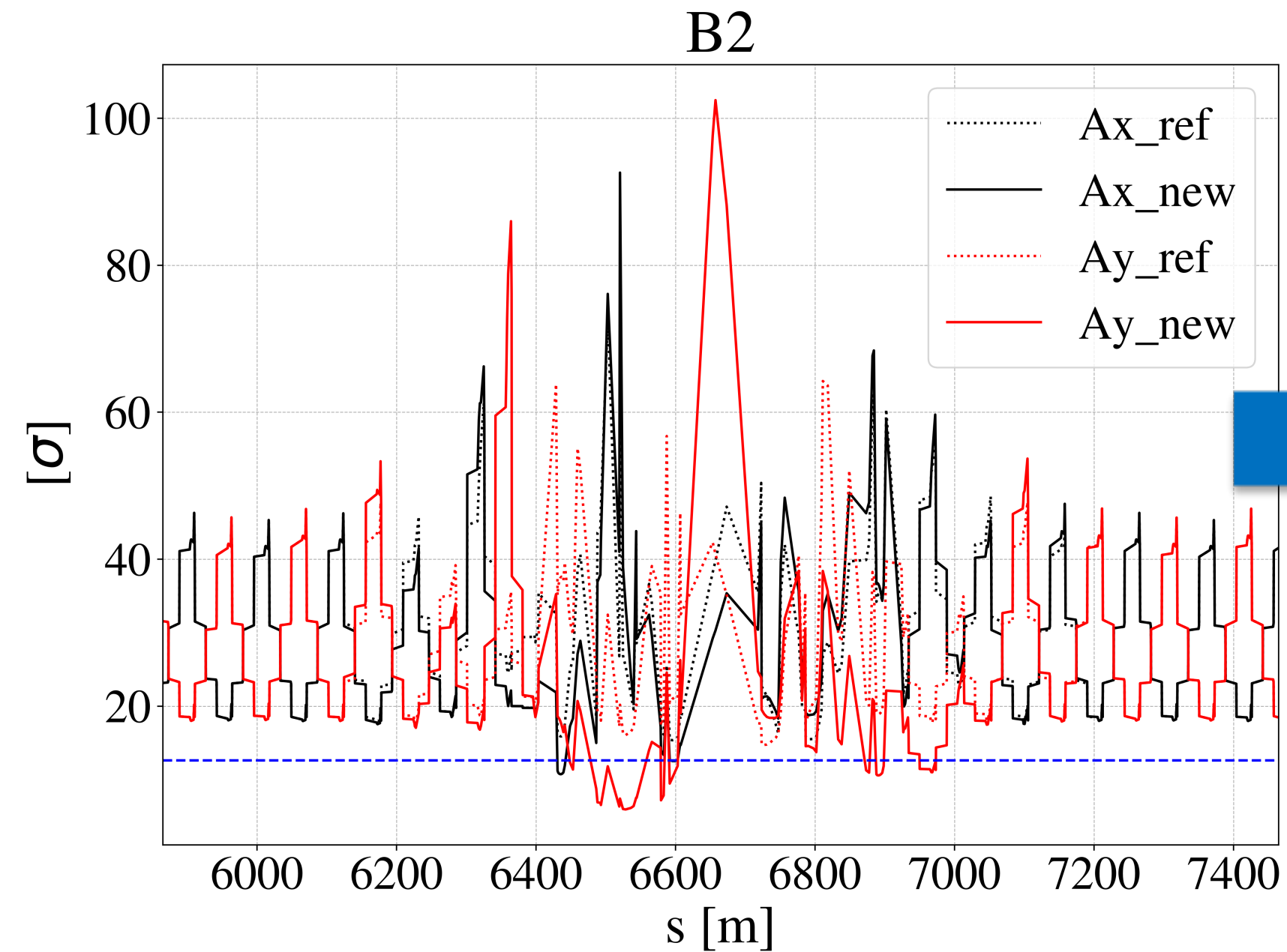

Need **combined ramp and desqueeze** of IR7 – never before done in collimation insertions

Collimator jaw movement during ramp

- **Non-monotonic** movement for some collimators
→ gap values at flat top are potentially affected by backlash creates backlash
- **Monotonicity** can be achieved by inserting the optics transition **earlier in the ramp**

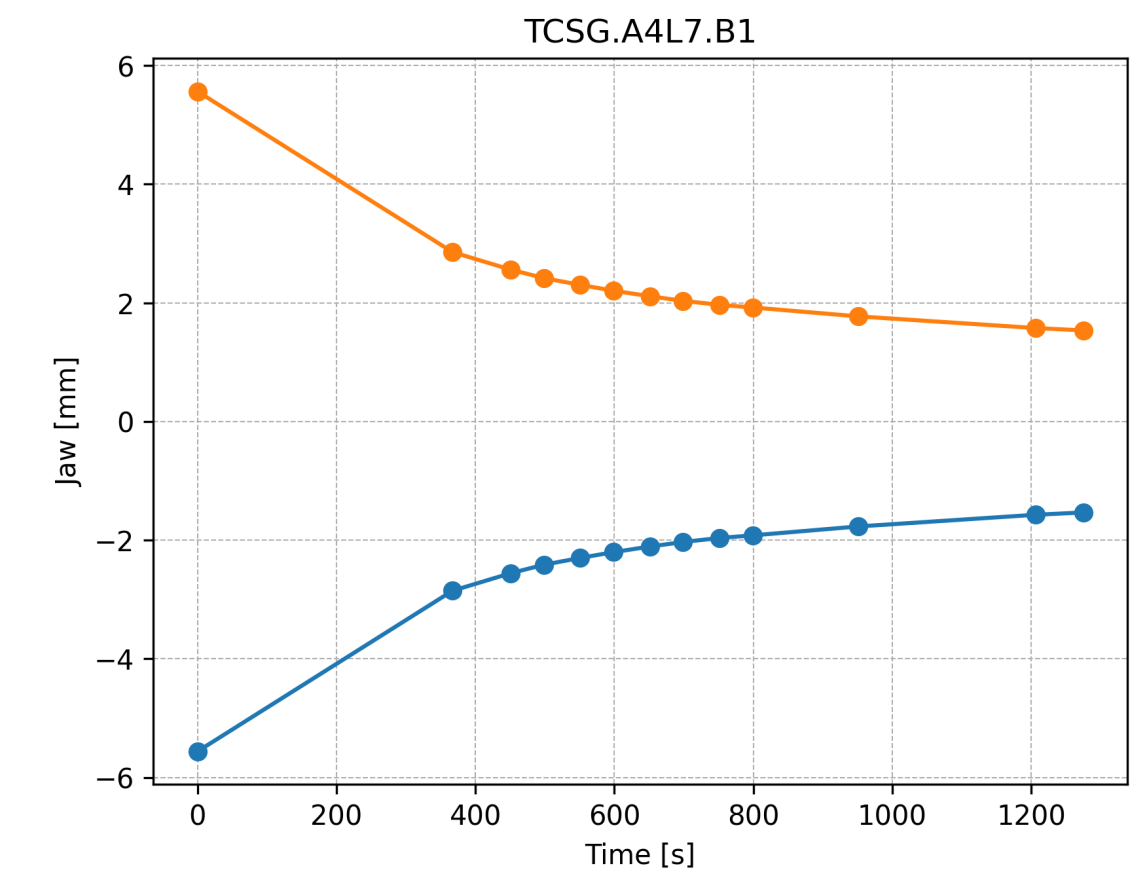
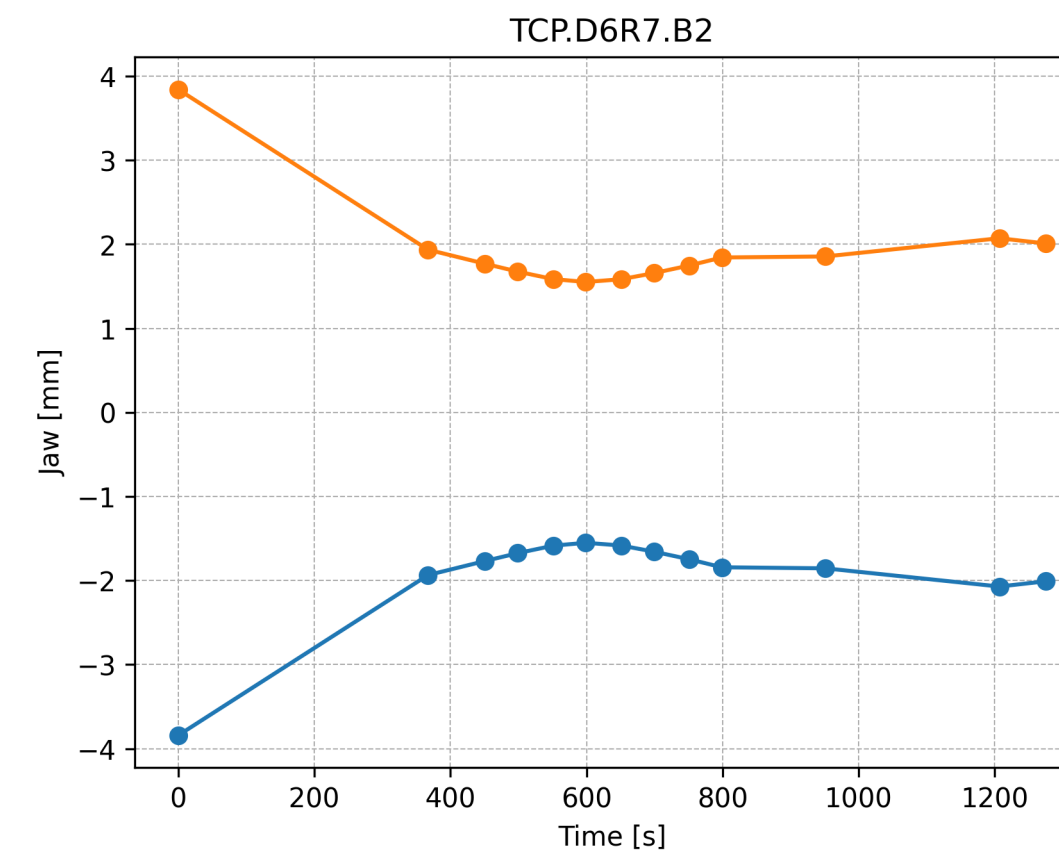

Experimental MDs in 2025

Björn Lindström,
L. Bertolozzi et al

- MD15146 – ramp and desqueeze with high intensity beams ✓
- MD17383 – squeezed β^* , TCT losses and experiment background ✓

Cleaning performance at FT

- Improvement (B2V): simulated 61% – measured 52% ($\sigma = 7\%$)

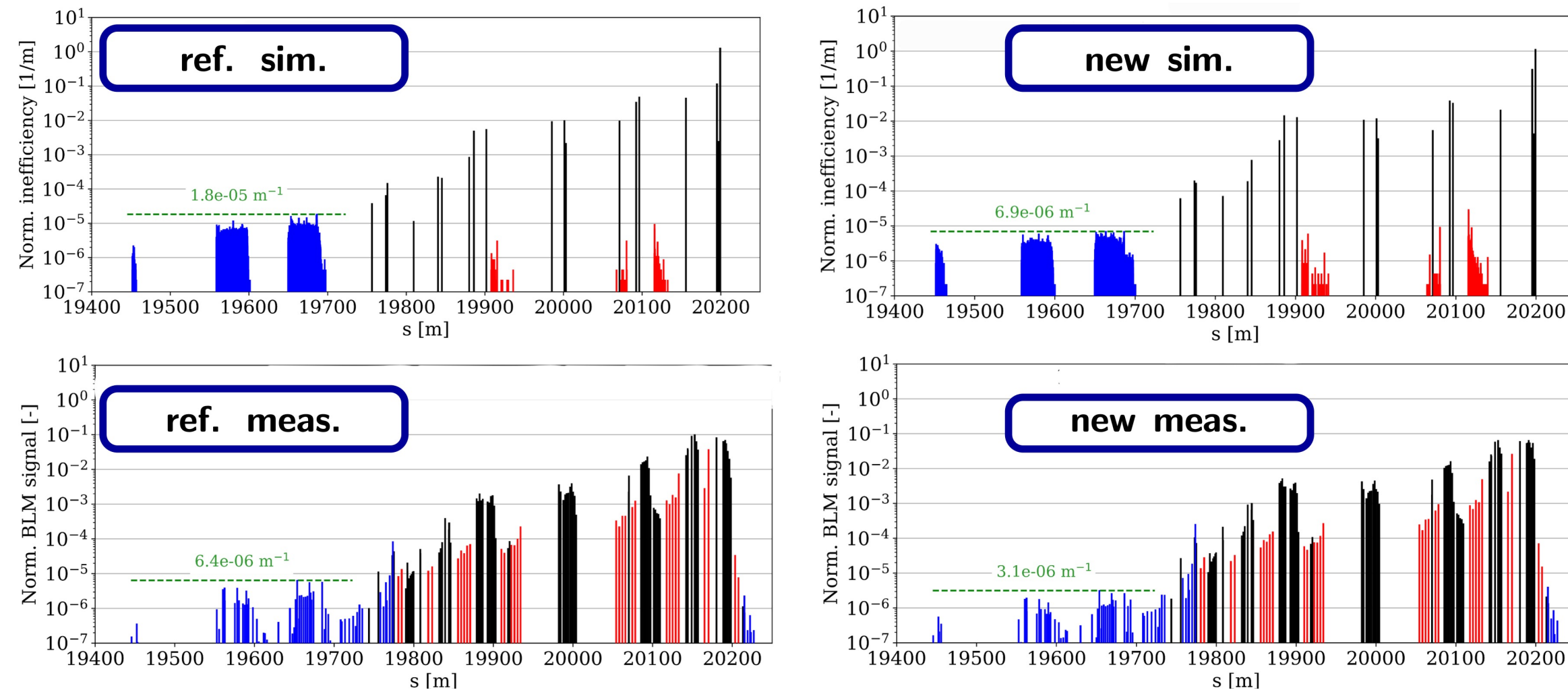

Conclusions

First new collimation optics in LHC successfully validated!

- Cleaning performance improved as expected
→ provides comfortable margins to quench limits
- Impedance improved as expected
→ helps ensure beam stability in HL era
→ provides more flexibility in choice of collimator settings
- New optics require combined ramp and desqueeze of IR7
→ no operational issues observed with high intensity beams
- TCT losses increase as expected, impact on experiment background is under evaluation
→ measurements below 1.2 m that were planned should be done

All set for HL-LHC!

Cleaning performance during ramp

- DS losses improve as new optics are inserted (405s and on)

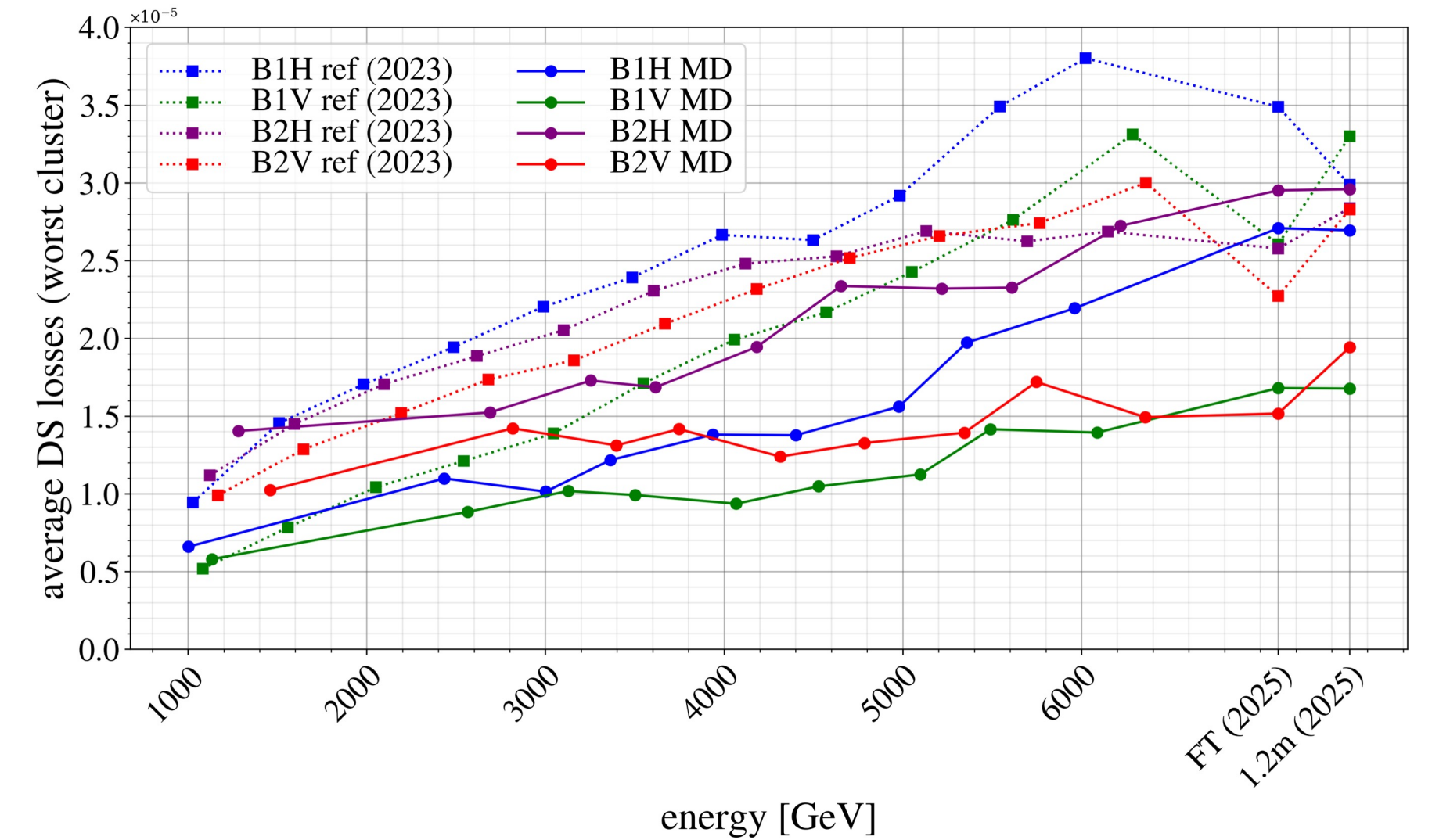

Beam lifetime with high intensity

- Lifetime consistent with nominal cycle

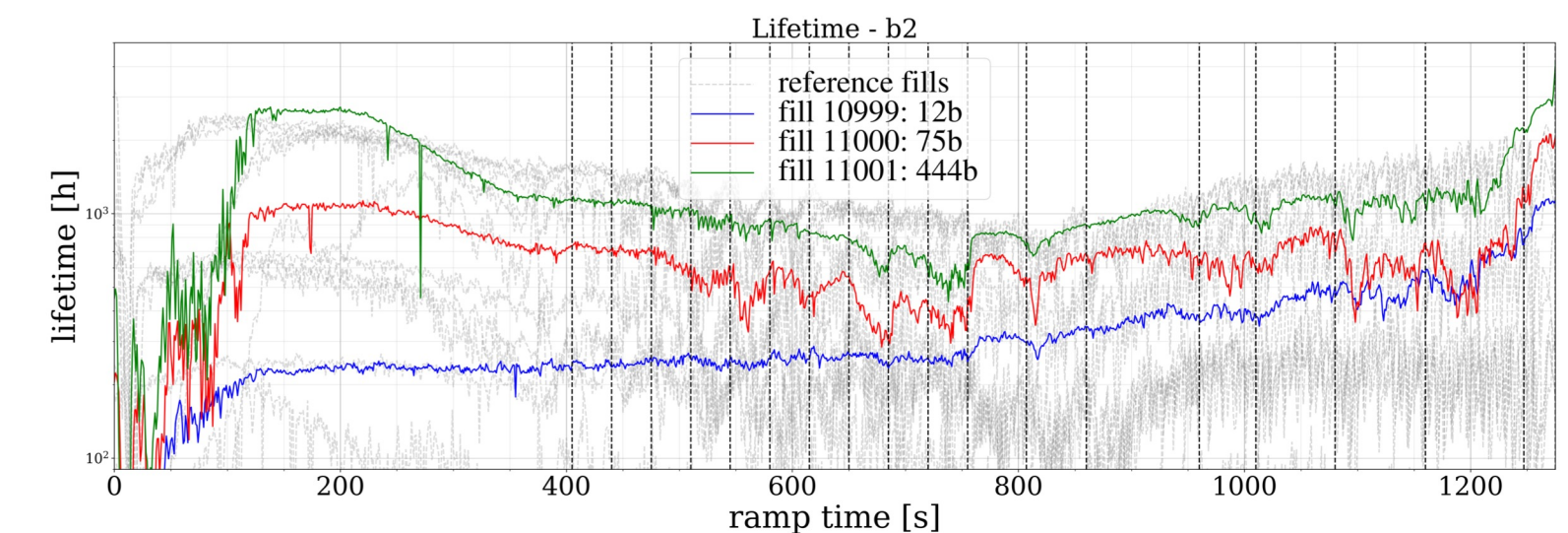
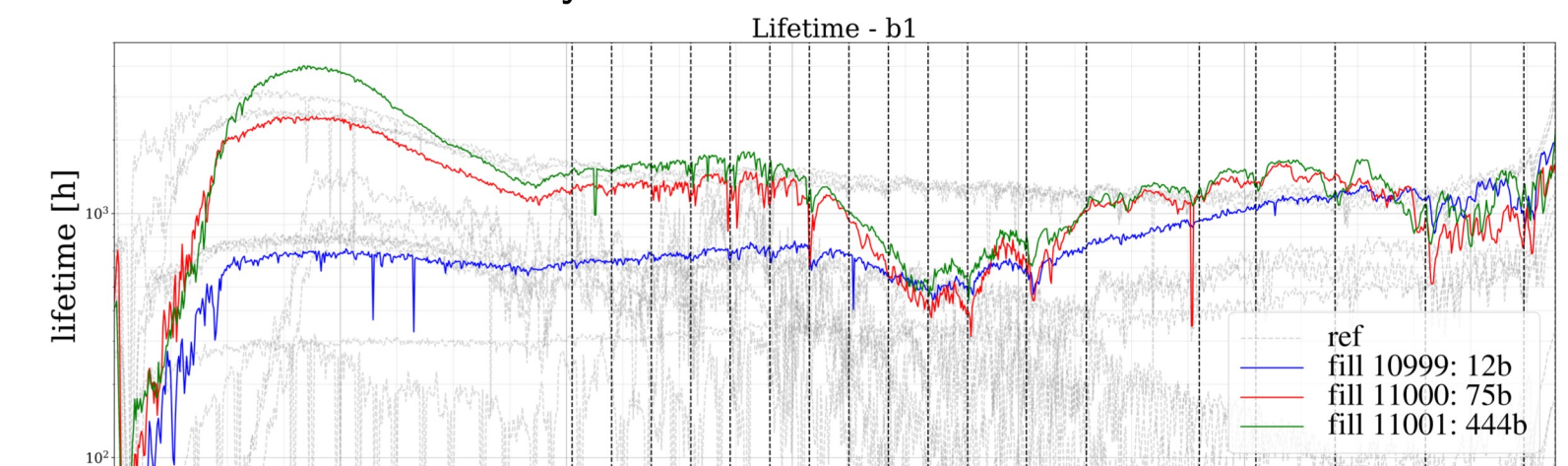

Nonlinear Dynamics for LHC

Sasha Horney PhD (Philip Burrows, Ewen Maclean)



Resonance identification & impact:

- Identification of sources, resonance driving terms (RDT)
- Beta-beating and amplitude detuning analysis
- Lifetime and dynamic aperture improvement

Key achievements so far:

- Identified & corrected resonance at LHC injection, in operation since 2024
- Measured sextupole RDT decay along LHC acceleration ramp for first time
- Gravitational tides & effect on LHC, HL-LHC, FCC

New results on LHC since last AB:

- Implemented first nonlinear RDT correction *including* Long-Range Beam-Beam (LRBB)
- First benchmarking and correction of higher-order errors (via feed-down)

⇒ Thesis submitted in April 2026

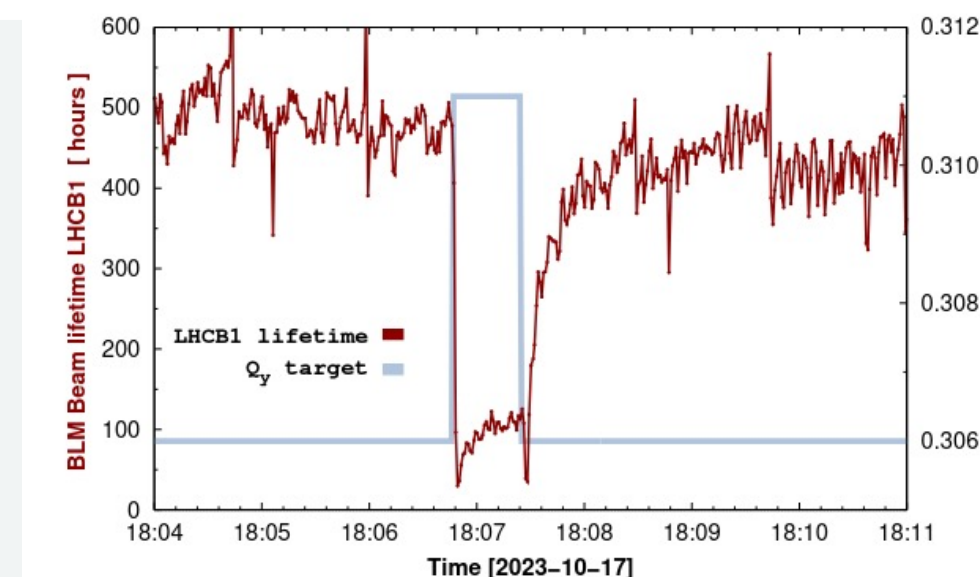

Measured lifetime (red) and set tune (grey) vs. time

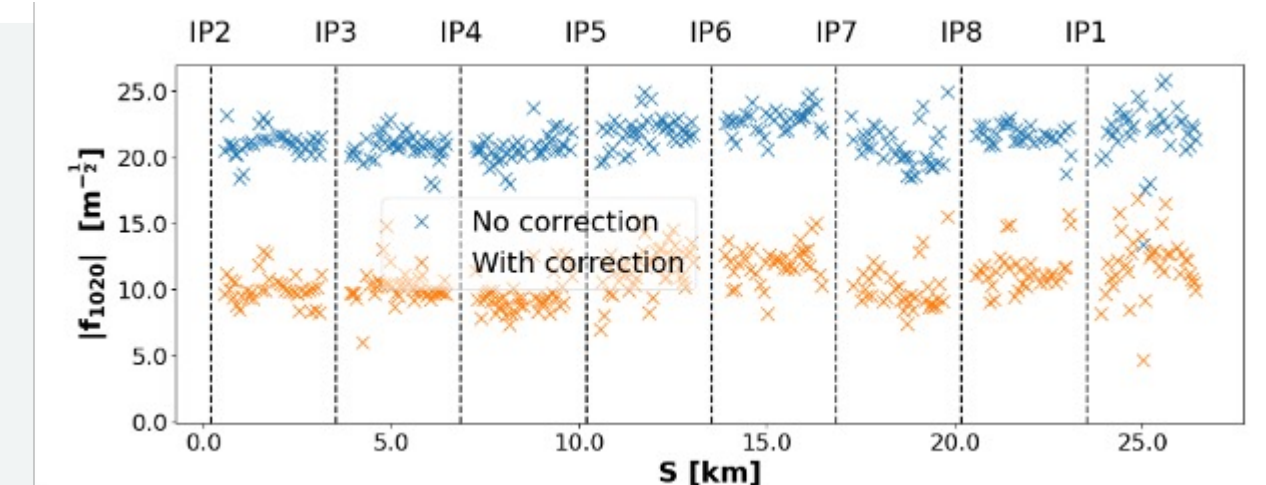

Measured sextupole RDT vs. distance along LHC at injection

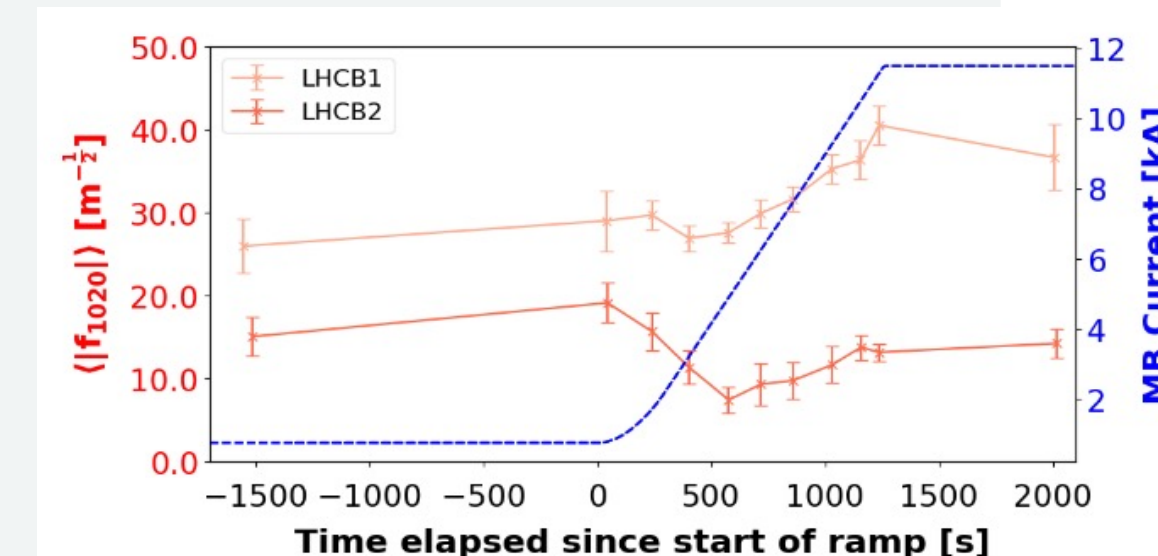

Measured sextupole RDT (red) and dipole current (blue) vs. time

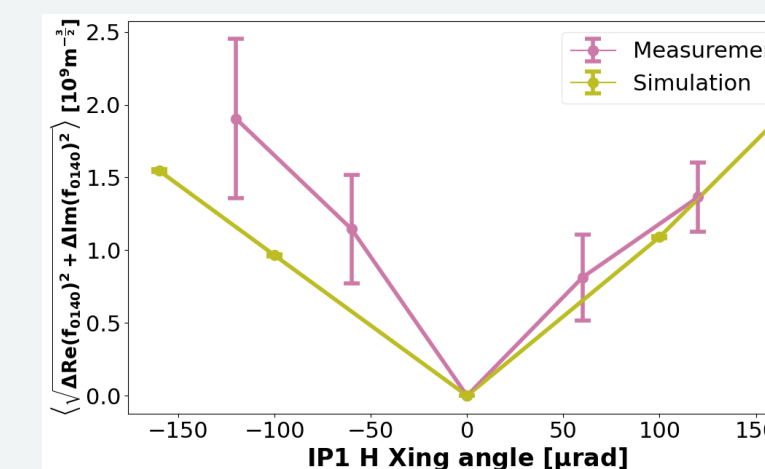

First dodecapole order RDT control

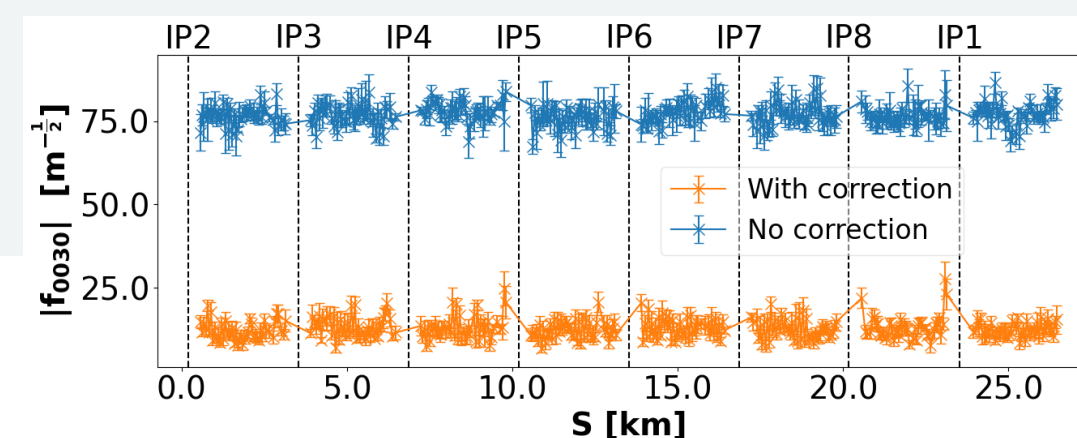

First correction of nonlinear RDTs and beta-beating including LRBB

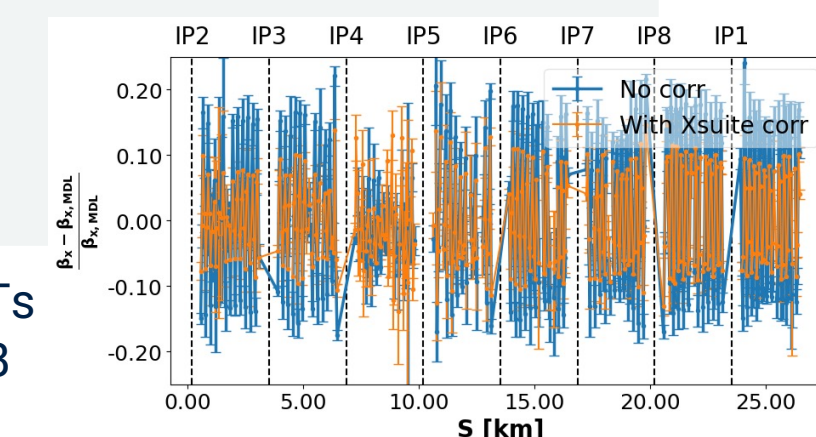

Data-driven Modelling: Control Nonlinearities

Adrian Oeftiger & CERN collaborators



UNIVERSITY OF OXFORD



Modelling & correcting nonlinear optics in Collider Rings key to high performance:

- CERN LHC experience: beam-based measurements + correction essential (Run 2+3)
- Recently developed **data-driven** modelling approach:
Deep Lie Map Networks

⇒ Differentiable simulations + measured turn-by-turn BPM data + stochastic gradient descent = “learn” multipoles in lattice

New results in collaboration with CERN (Joshua Gray, Kyriakos Skoufaris):

- LHC: measuring **energy-induced optics distortions** (using DLMN via MAD-NG framework)
⇒ DLMN-based reconstruction outperforms state-of-the-art approach (global phase response matrix) → 2 IPAC'26 publications

Plans:

- PhD student R. Simpson to start at Oxford in 2026: include collective effects in DLMN (ISIS + GSI/FAIR funded)

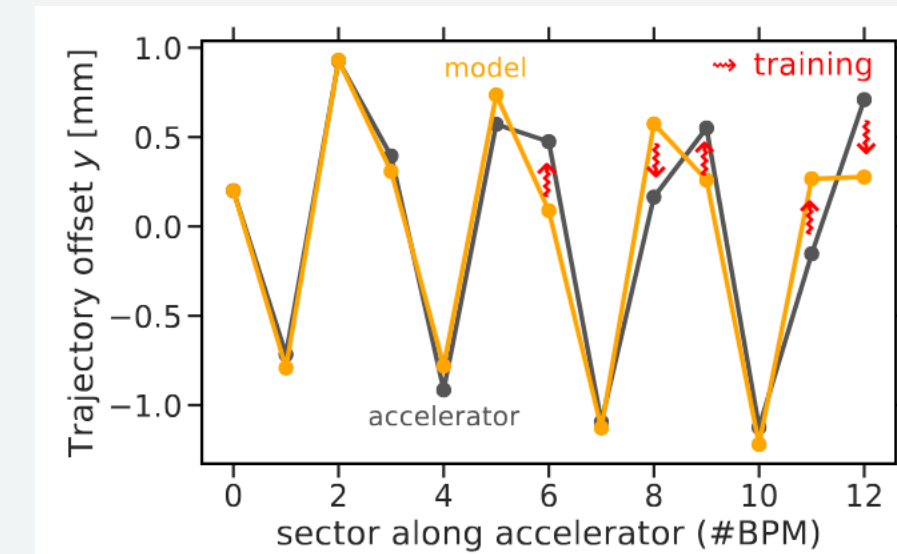

DLMN training procedure, learn multipoles to fit predicted trajectory to measured one

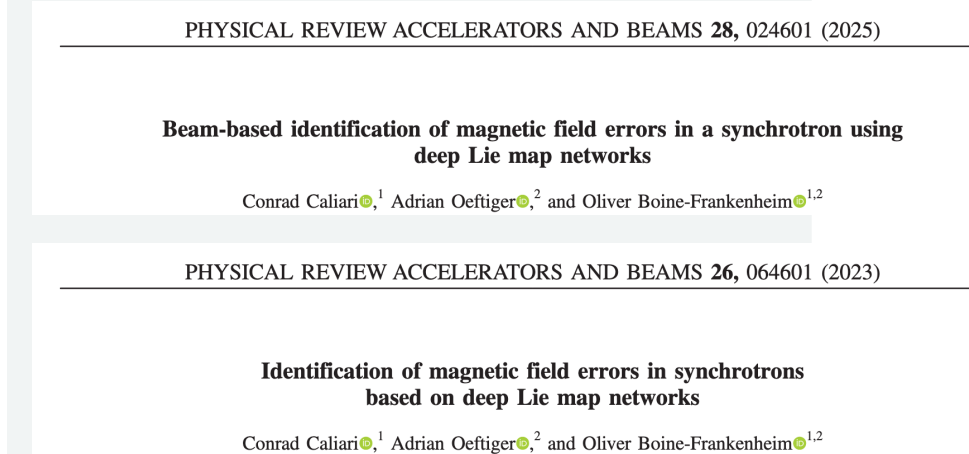

Arc-by-arc reconstruction of energy-induced optics distortion in CERN's LHC [IPAC'26]: more accurate energy offset measurements with DLMN

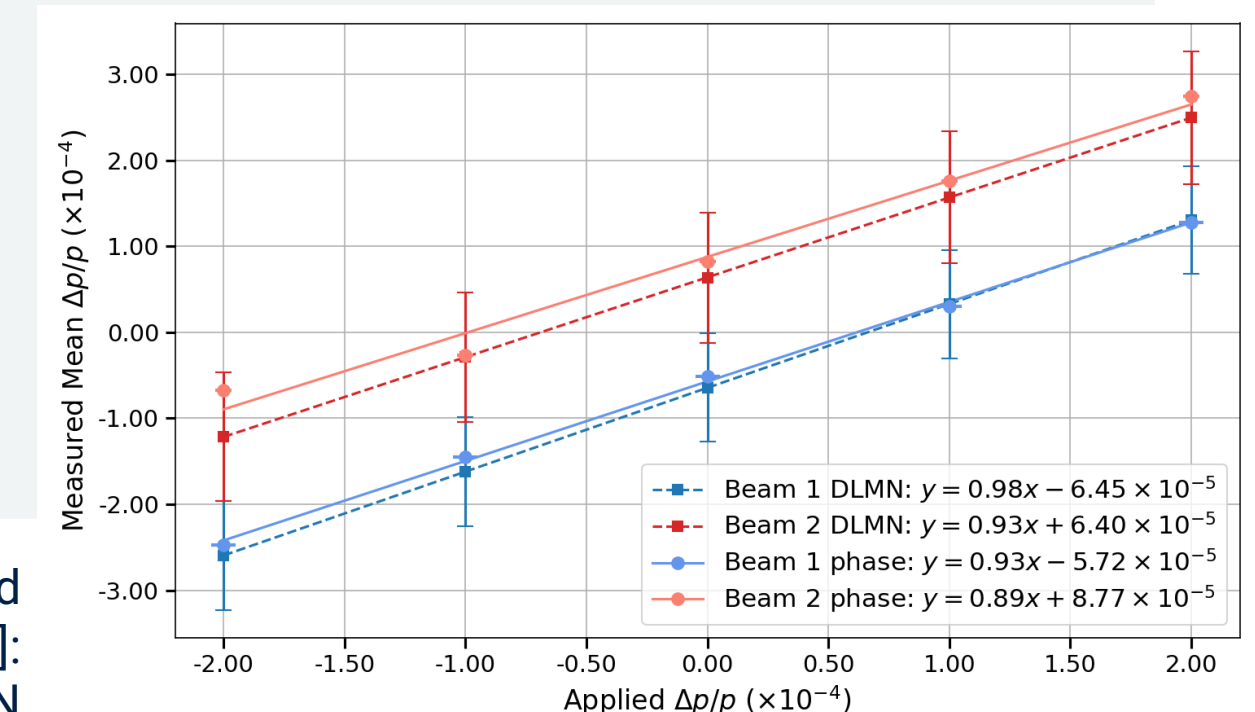

Beam Stability vs. Beam Lifetime?

Adrian Oeftiger & Hadron Beam Physics Group



Today, main strategy to mitigate instabilities in hadron Colliders:

- **Passive: Landau damping** via octupoles (+ high chromaticity)
- **Active: feedback** (only lower frequencies)
 - ⇒ high frequencies of intra-bunch instabilities challenging for feedbacks
 - ⇒ passive strategy for head-tail and e-cloud instabilities!

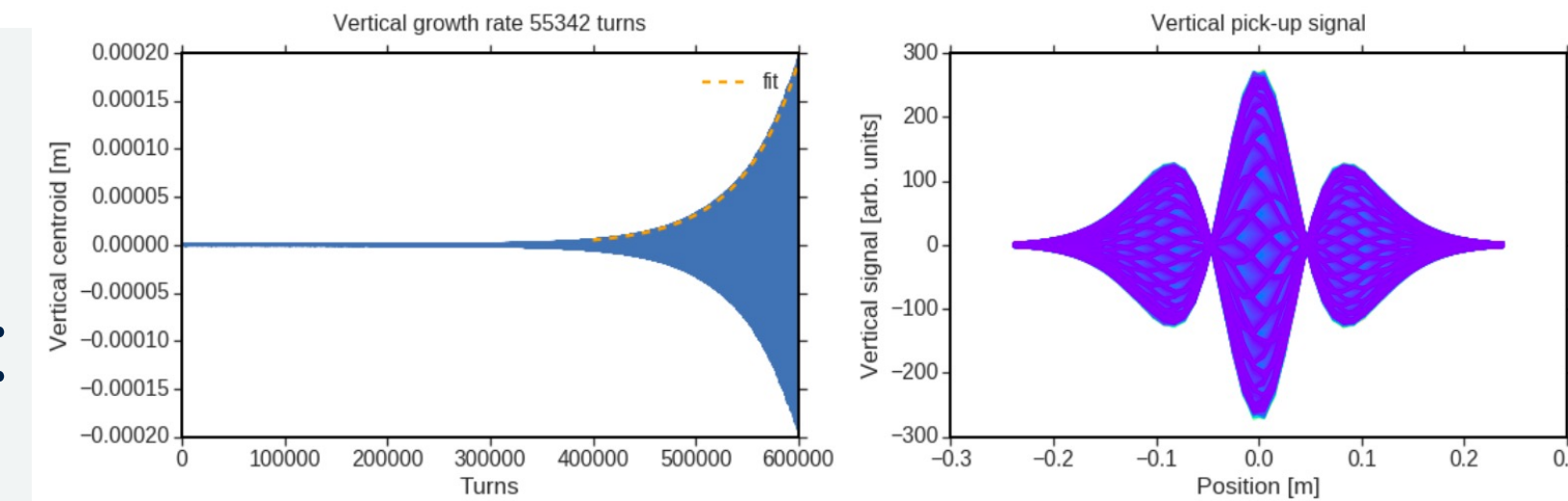

Head-tail instability in LHC with feedback but without octupoles [Oeftiger, HL WP2 2018]

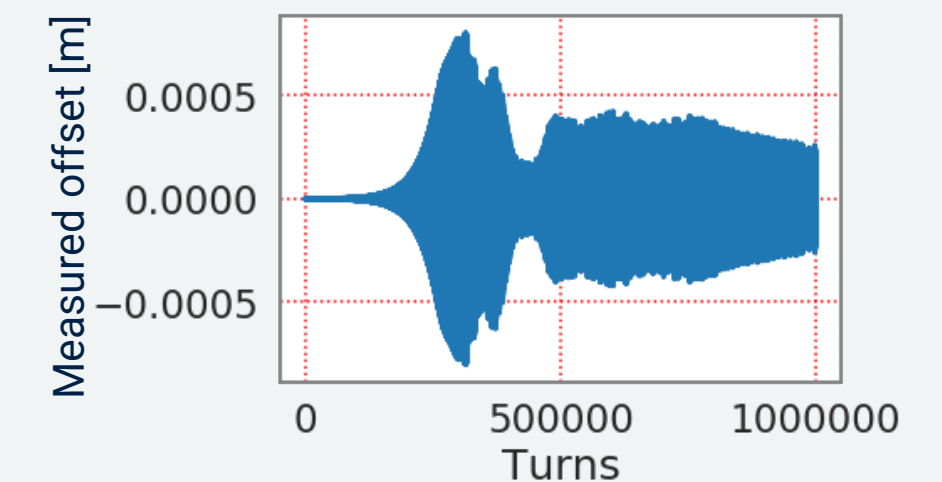

Problematic: beam stabilisation at the expense of beam lifetime

- Octupoles provide detuning with increasing amplitude: tails!
 - ⇒ Octupole nonlinearities affect dynamic aperture (DA)
 - ⇒ CERN LHC Run 2: Landau octupoles provided key DA degradation
- In view of future colliders: alternative stabilisation approaches?
 - ⇒ **New PDRA (STFC-funded)**

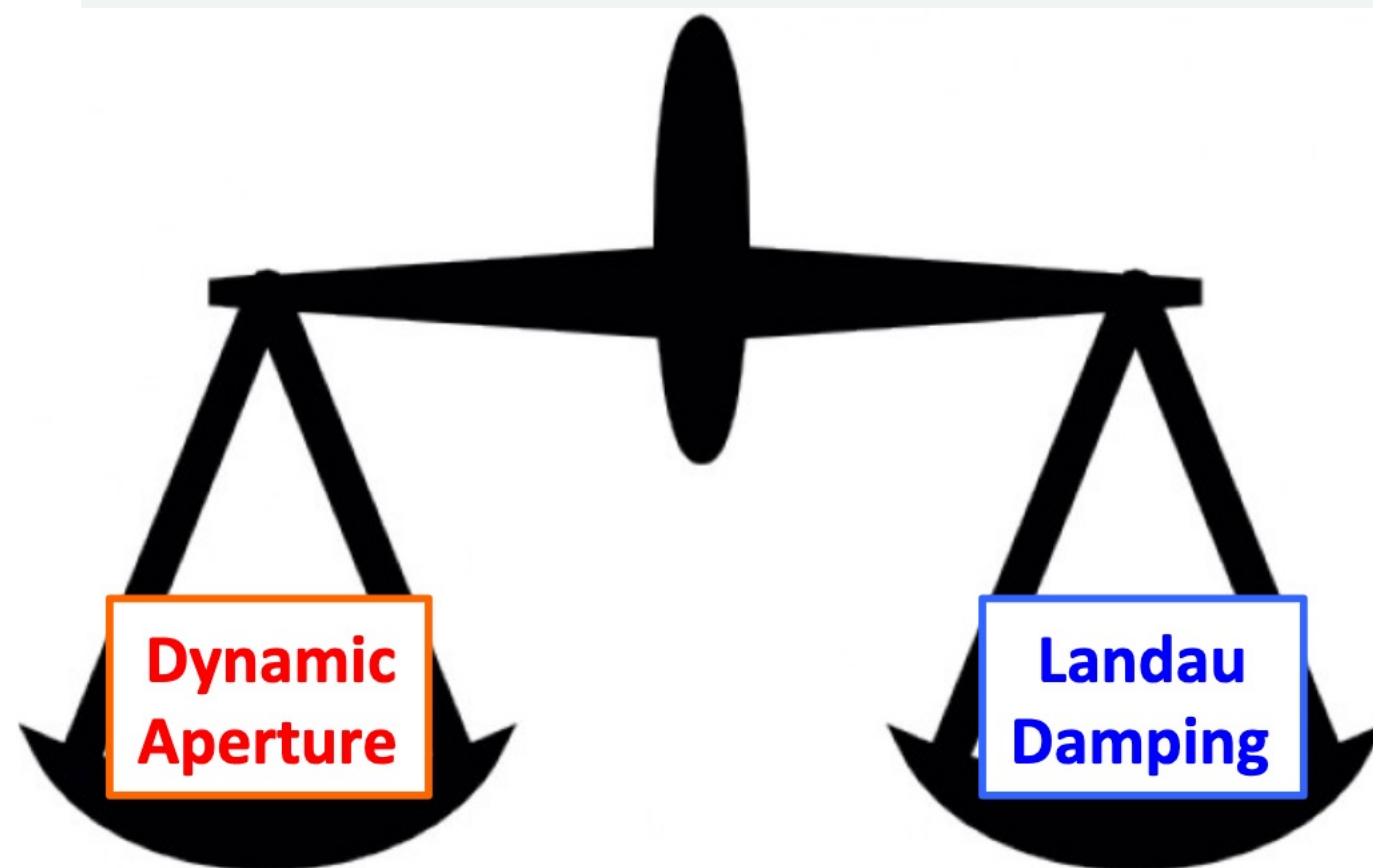

Beam Stability vs. Beam Lifetime!

Max Topp-Mugglestone, Adrian Oeftiger



PRL 119, 134802 (2017)

PHYSICAL REVIEW LETTERS

week ending
29 SEPTEMBER 2017

Landau Damping of Beam Instabilities by Electron Lenses

V. Shiltsev, Y. Alexahin, A. Burov, and A. Valishev

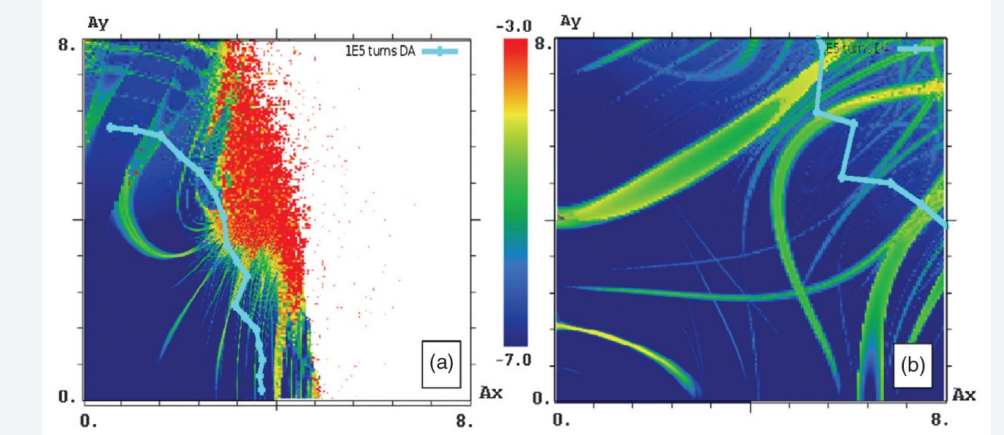

DA impact for HL-LHC:
octupoles (left) vs. e-lens (right)

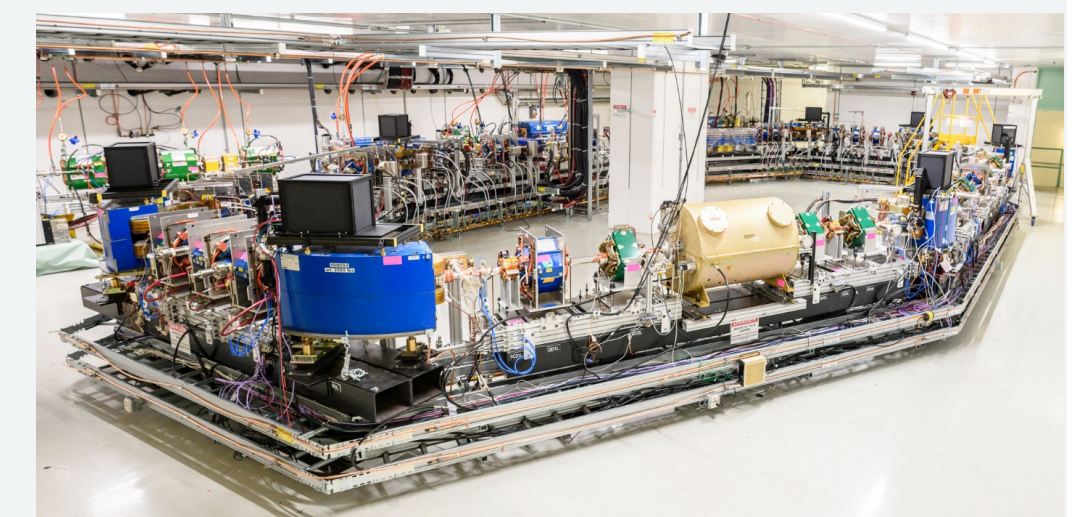

Landau electron lens to be studied at IOTA!

New PDRA, Max Topp-Mugglestone, started at Oxford in Feb 2026:

Investigate *alternative instability mitigation* approaches

- Active: **Landau electron lenses** (e-lenses)
 - ⇒ FCC-hh: Landau damping with one 2m-long e-lens = >1000 octupoles!
 - ⇒ No impact expected on DA! (Detuning through beam core, not tails!)
- Dual use possible with 2 cathodes:
active halo control (hollow e-beam) + Landau damping (Gaussian e-beam)
- Passive: **Direct space charge**

Plans:

- HL-LHC simulations: study DA for e-lens and characterise instabilities
- LHC experiments: drive space-charge-induced Landau Damping study
- Contribute to Fermilab's IOTA experiments with Landau e-lens
- Design Landau e-lens proof-of-principle experiment for SPS/LHC

First results, Dynamic Aperture
computations for HL-LHC (March '26)

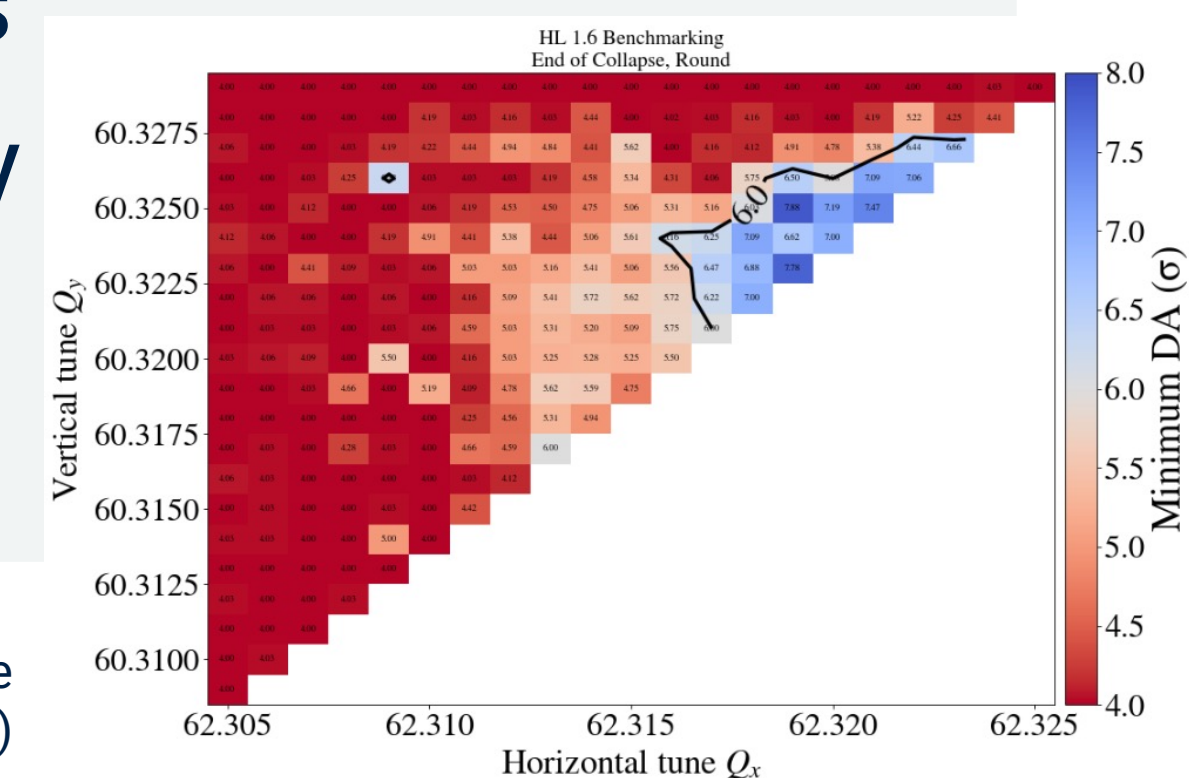

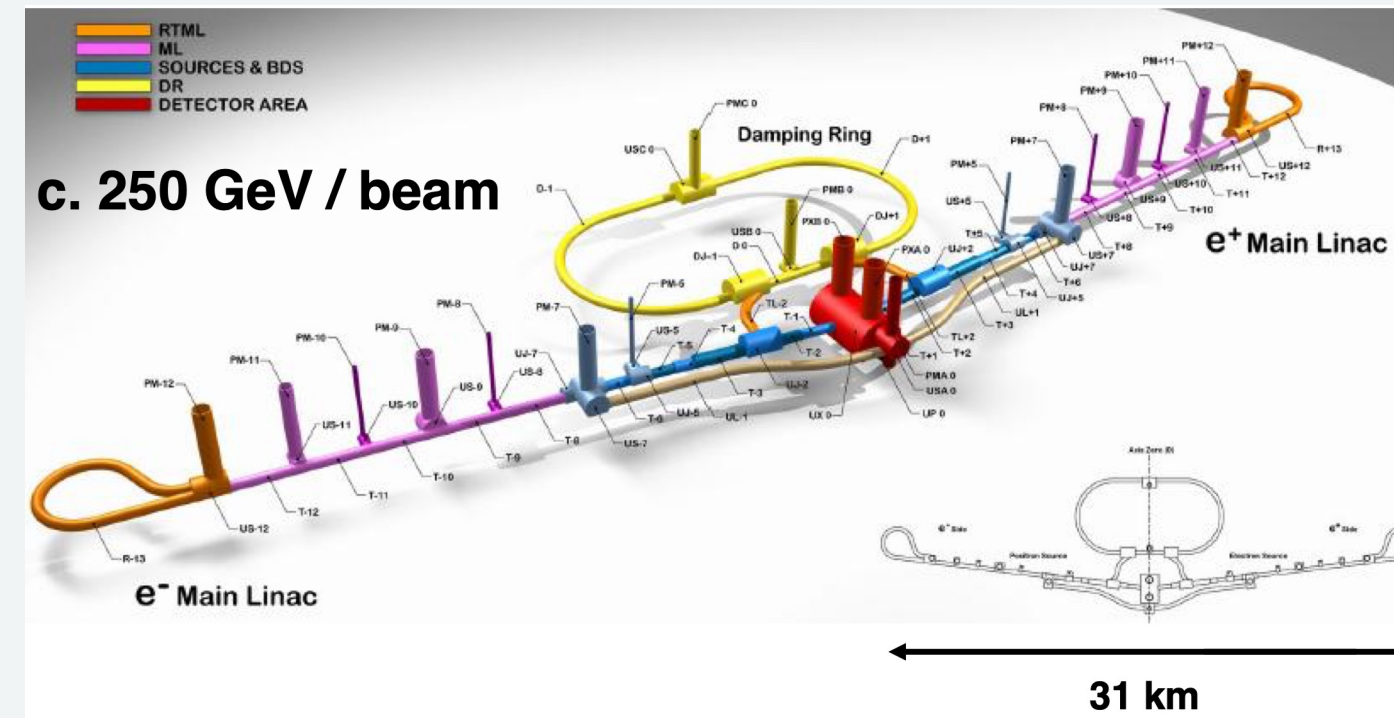

2. Future electron-positron Higgs factories

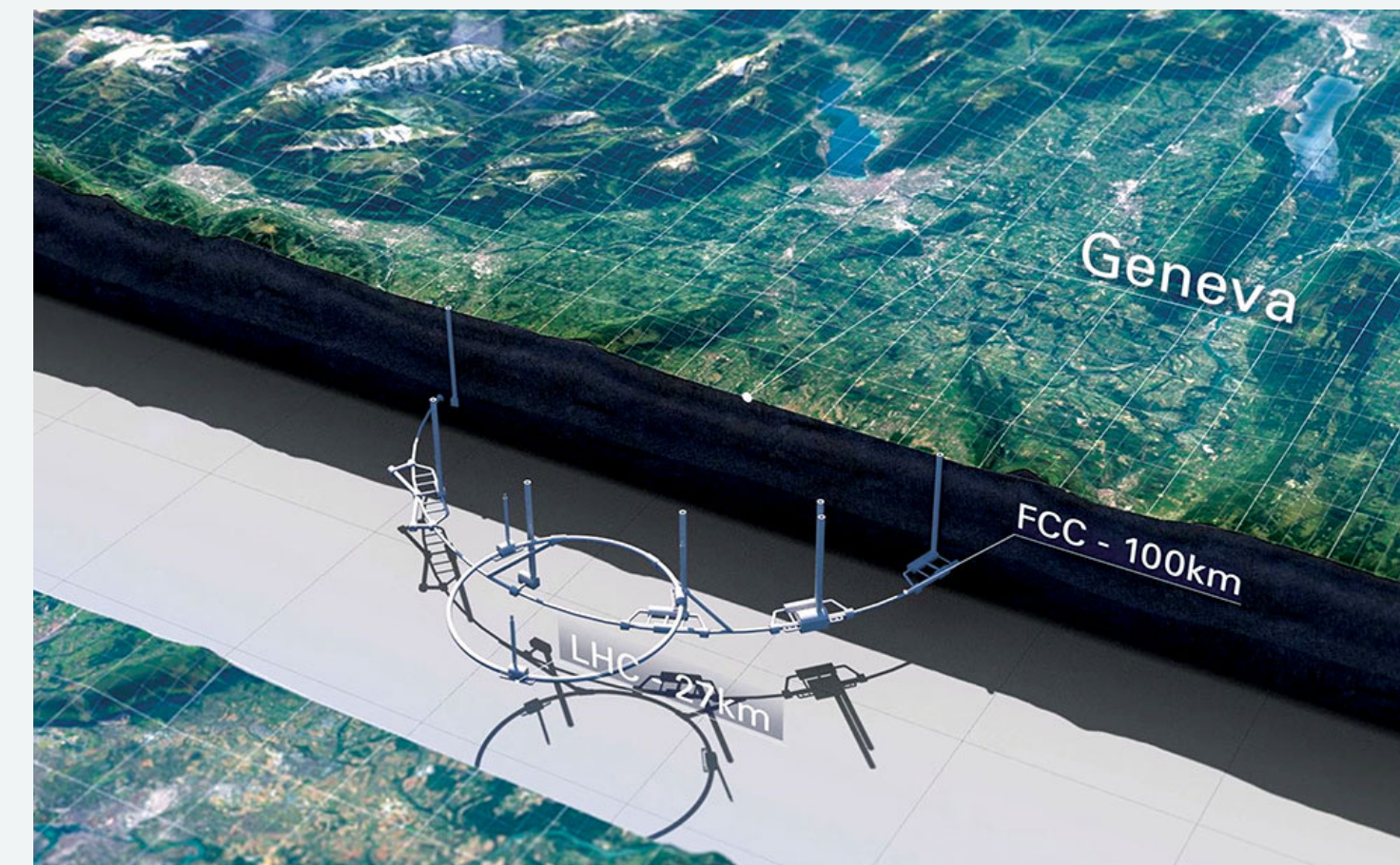
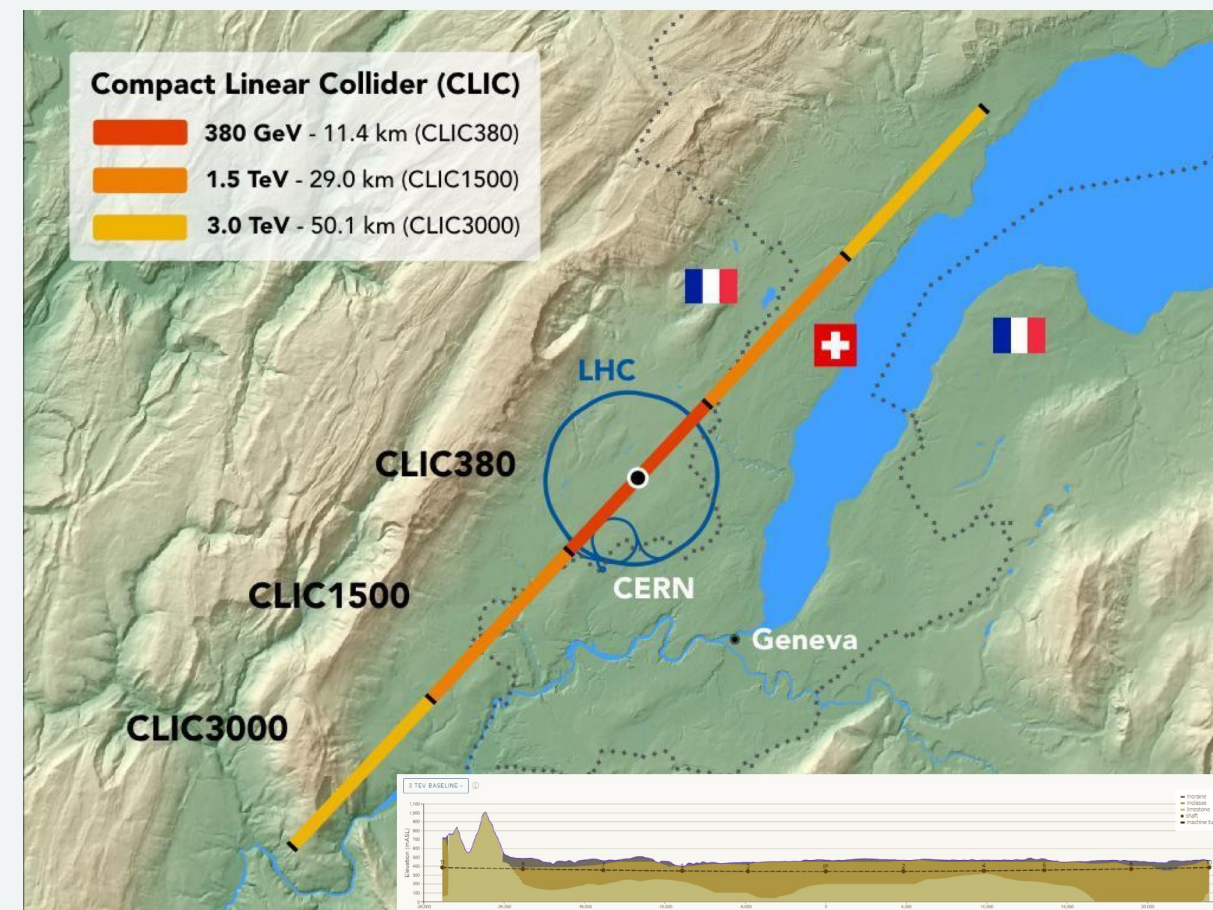

Overview: Future Higgs Factories

JAI has a very strong background in key technologies and systems for any collider:

Beam delivery system, machine-detector interface, luminosity beam-collision feedback, beam dynamics, instrumentation, alignment systems ...

Maintaining a **strategic position** that covers options for the collider:

- **ESPPU: Burrows** co-convenor of Preparatory Group on Accelerator Science & Technology, member of European Strategy Group, and co-convenor²³ of ESG WG 2a – Assessment of Large-Scale Accelerator Projects at CERN
- **FCCee:**
 - Emily Howling** PhD on FCCee main ring BPMs (**Burrows**/Gasior)
 - Jack Salvesen** PhD on IP feedback system (**Burrows**/Zimmermann)
- **ILC:** JAI continues to play leading role in **International Development Team (IDT):**
 - WG2: Accelerator:** **Burrows** UK lead
 - WG3: Physics/detectors:** **Burrows** on Steering Group
 - ATF3:** **Bett/Korysko** re-commissioning beamline
- **CLIC:** **Burrows** (Spokesperson 2014-20) on Steering Committee
- **LC Vision:** Linear collider facility for CERN – **Burrows** on Steering Group
- **CEPC:** **Foster** chairs International Advisory Board

Commissioning of Orbit Feedback at ATF3

Doug Bett, Philip Burrows

Visits to KEK supported via EAJADE

Nanobeam production at KEK/ATF3: FONT orbit feedback studies

- The ATF3 upgrade aims to deliver operation at higher charges with more stable beam conditions overall
- Recent studies have aimed to take advantage of the improved resolution and more highly correlated bunches to deliver improved performance of the **bunch-by-bunch feedback system**

beam size
[μm]

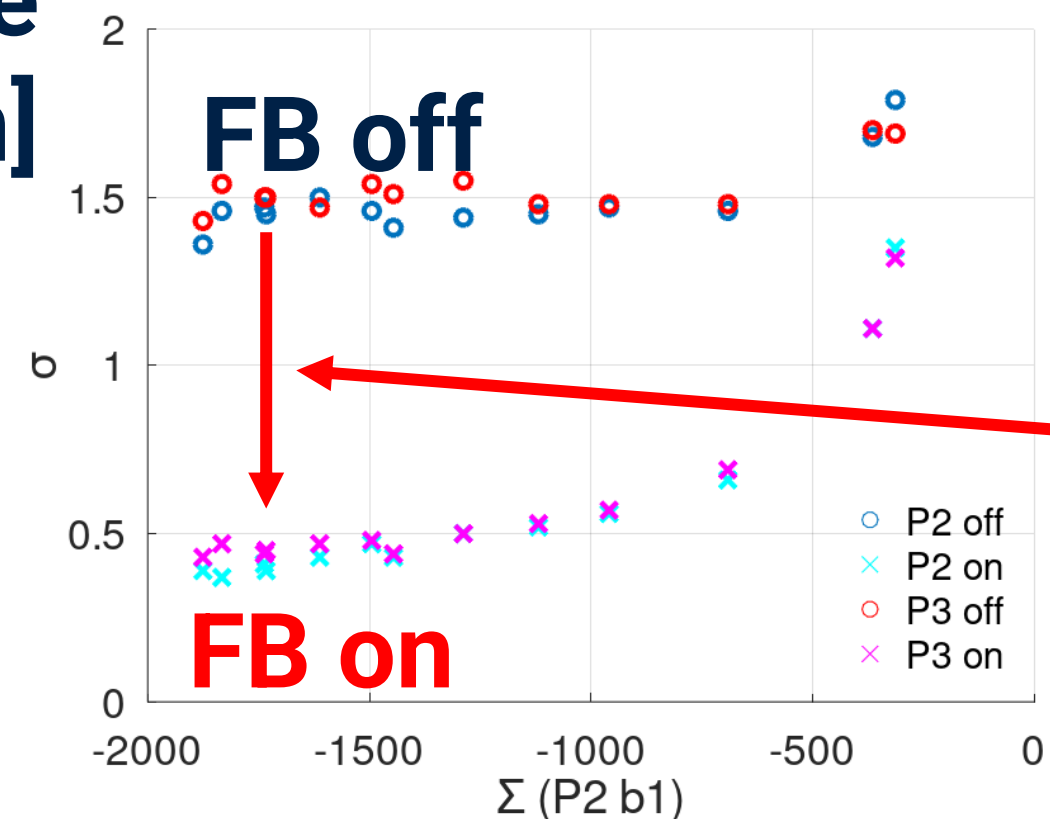

← charge

Feedback performance increases as a function of charge, though the charges attained for this study are not significantly higher than observed in past studies

Bunch corrected to $<0.5\ \mu\text{m}$ at both BPMs, consistent with a resolution of 350 nm

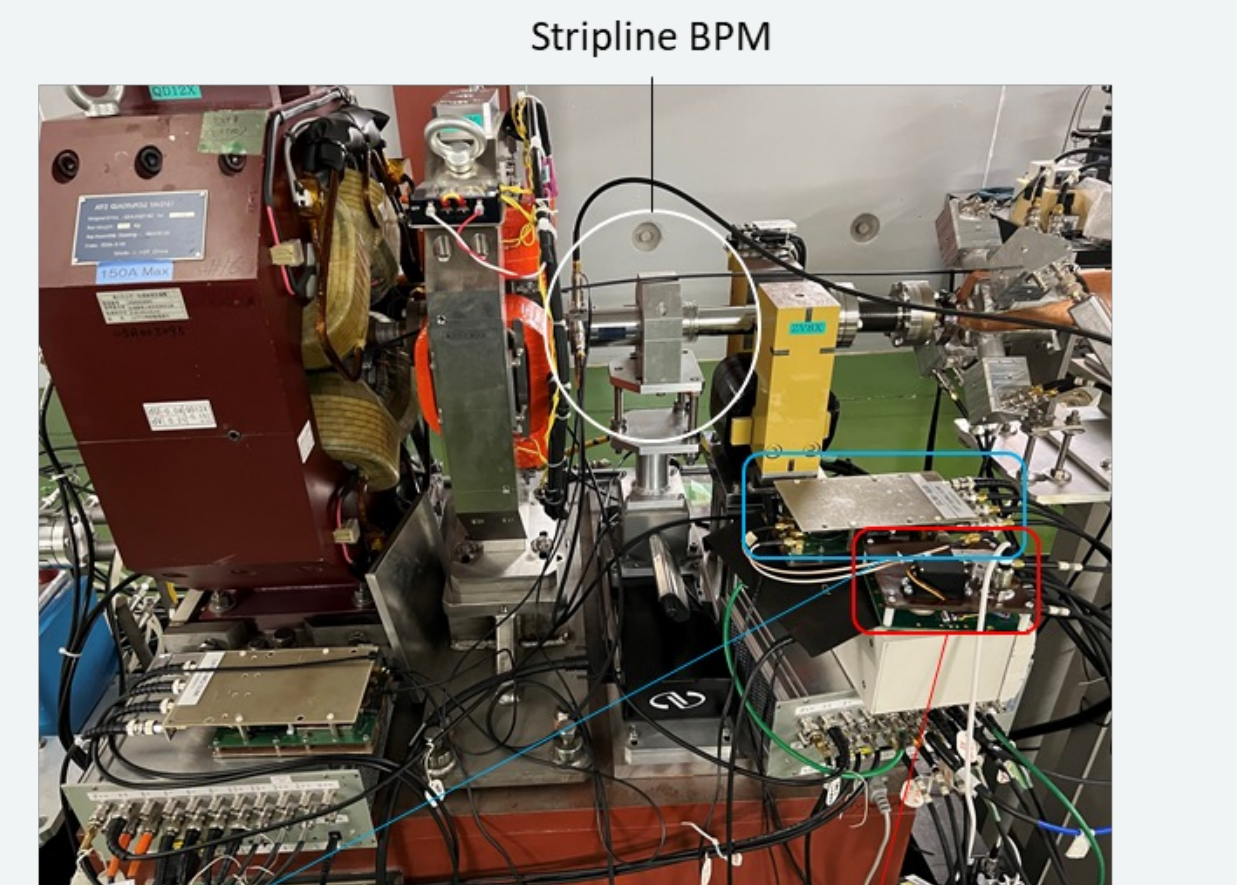

Analogue processor

Stripline phase shifter (replaced)
Delay stripline signals so they arrive at the analogue processor at the same time

IP Feedback Systems for FCCee

John Salvesen PhD (Philip Burrows, Frank Zimmermann)



UNIVERSITY OF OXFORD



FCCee design being informed by extensive FONT design work for Linear Colliders, and by operating experience from SuperKEKb *iBump* FB system

- **FB input signals analysis:** beam-beam deflection, luminosity degradation, beamstrahlung.
[10.18429/JACoW-IPAC2024-THPG31](https://doi.org/10.18429/JACoW-IPAC2024-THPG31)
- **FB performance analysis:** machine stability with offsets (IPAC'25)
[10.18429/JACoW-IPAC2025-THPS012](https://doi.org/10.18429/JACoW-IPAC2025-THPS012)
- **SuperKEKB *iBump* FB in operation:** two dedicated MD periods
[10.18429/JACoW-IPAC2025-THPS011](https://doi.org/10.18429/JACoW-IPAC2025-THPS011)

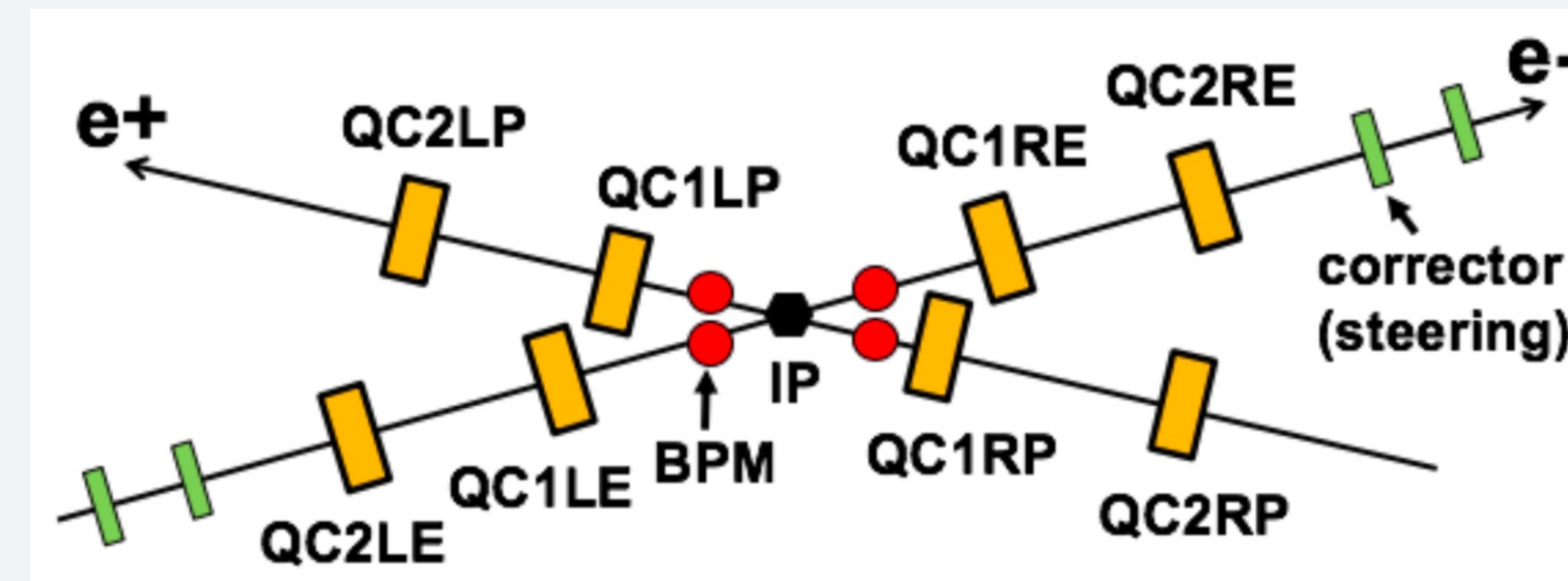

Schematic overview of *iBump* Feedback System

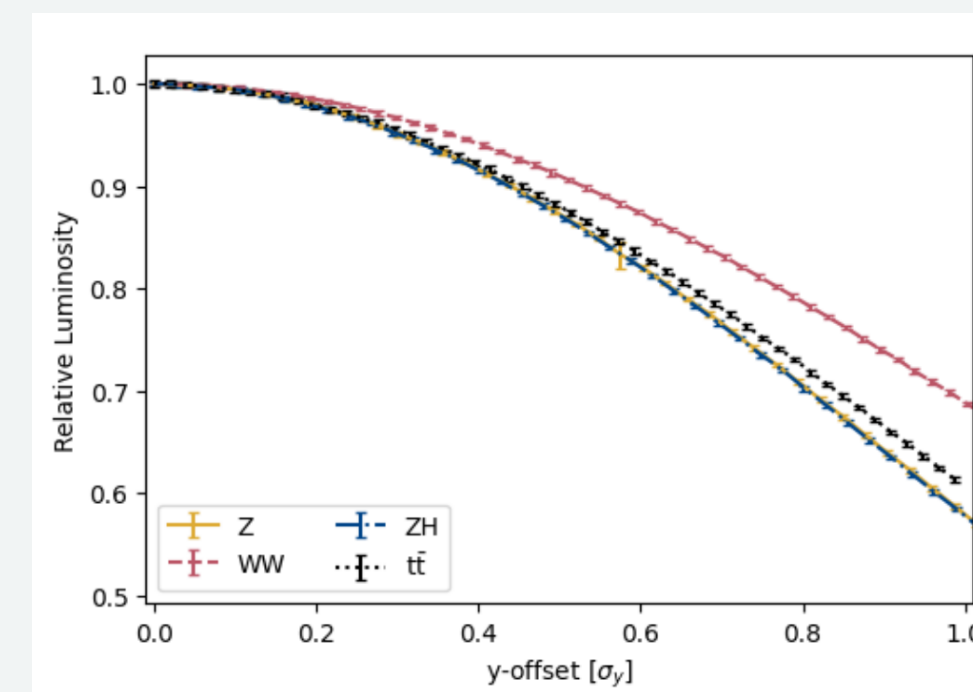

Luminosity as a function of incident beam offset

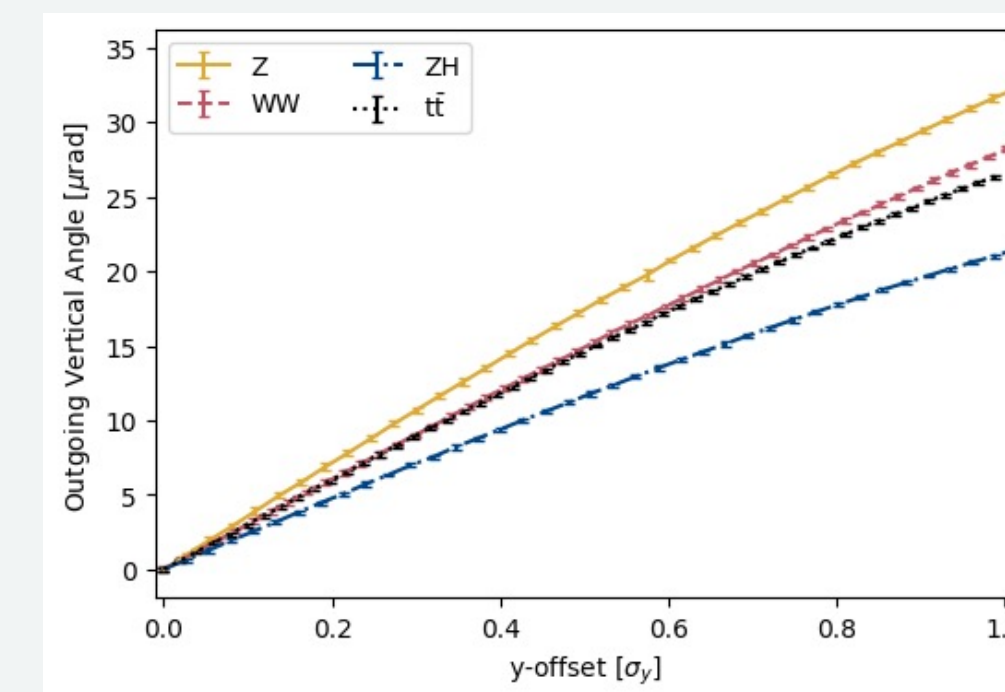

Outgoing centroid beam deflection as a function of incident beam offset

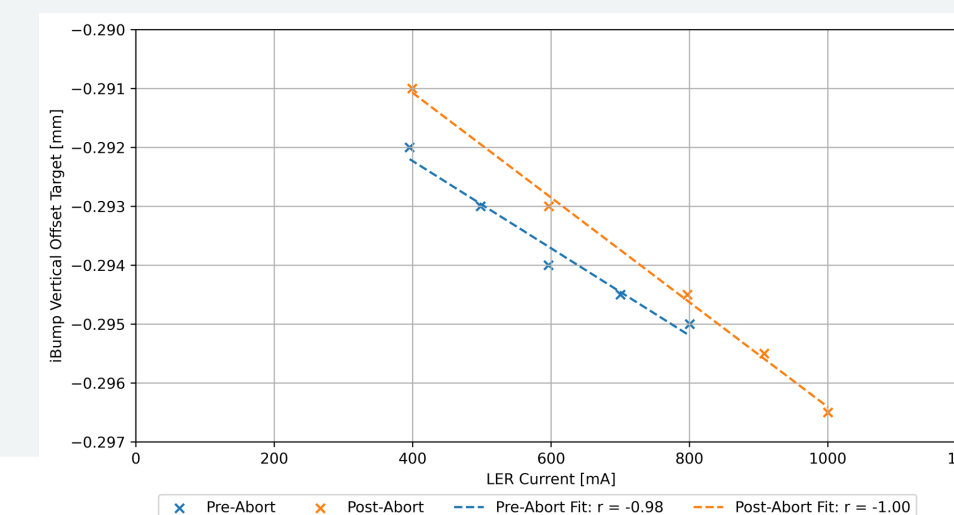

Experimental results for calibration of SuperKEKB *iBump* FB

Visits to KEK supported via EAJADE

IP Feedback Systems for FCCee

John Salvesen PhD (Philip Burrows, Frank Zimmermann)



UNIVERSITY OF
OXFORD



Analytic IP Feedback Model derived

- Integral linear prediction feedback identified as a leading candidate for FCC-ee
- Issues identified regarding FCC-ee parameter sets (now revised)

26

Tracking simulations including IP feedback for both FCC-ee and SuperKEKB developed

- Models developed in Xsuite
- Including strong-strong beam-beam, quantum synchrotron radiation and full lattice tracking
- Performance of feedback evaluated

⇒ Thesis submitted in March 2026, CERN-QUEST starts in May 2026, named BELLE-II subgroup co-coordinator “Simulations and Modelling”

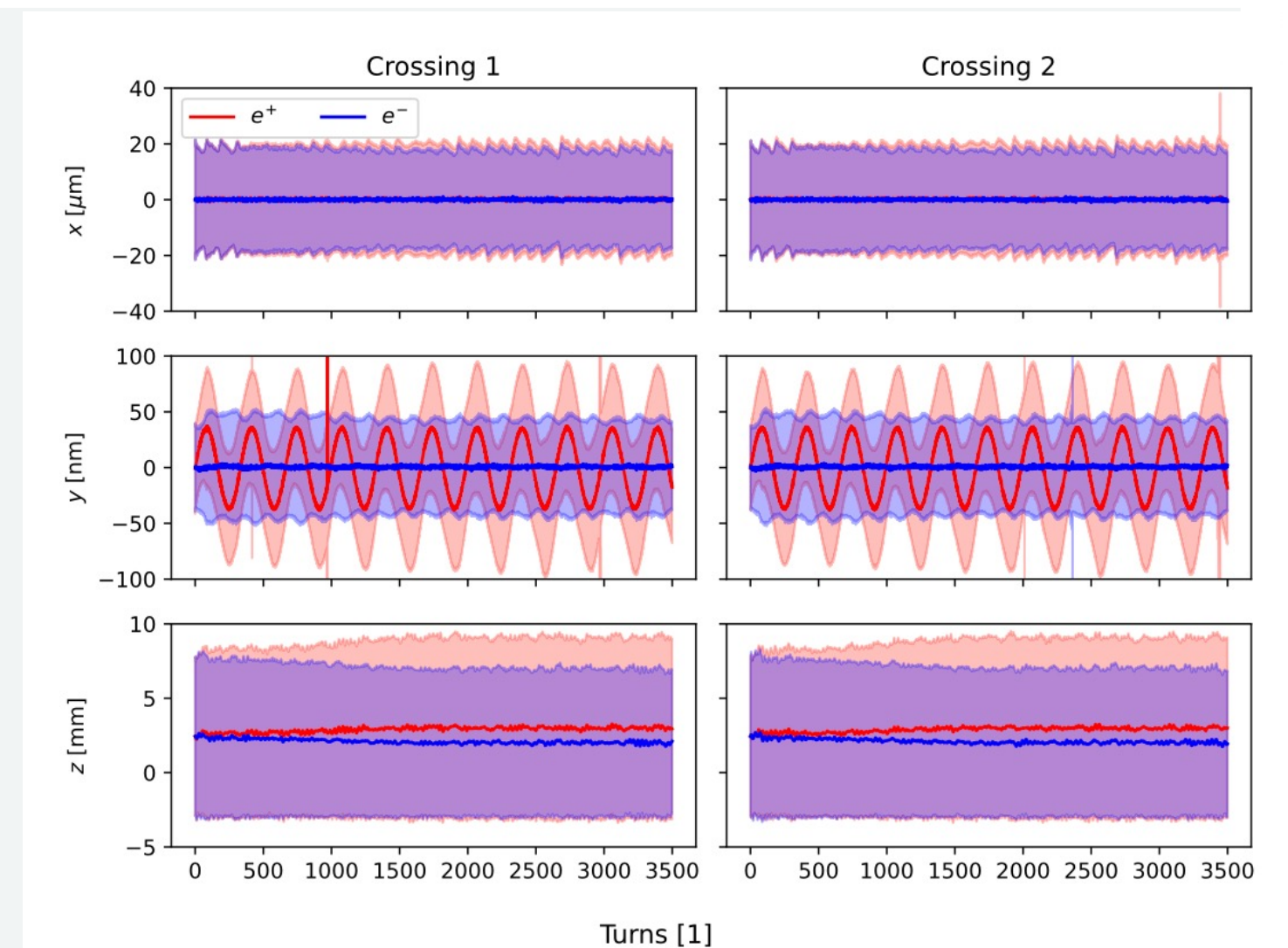

FCC-ee with driven sinusoidal error
Top: without IP feedback
Bottom: with IP feedback

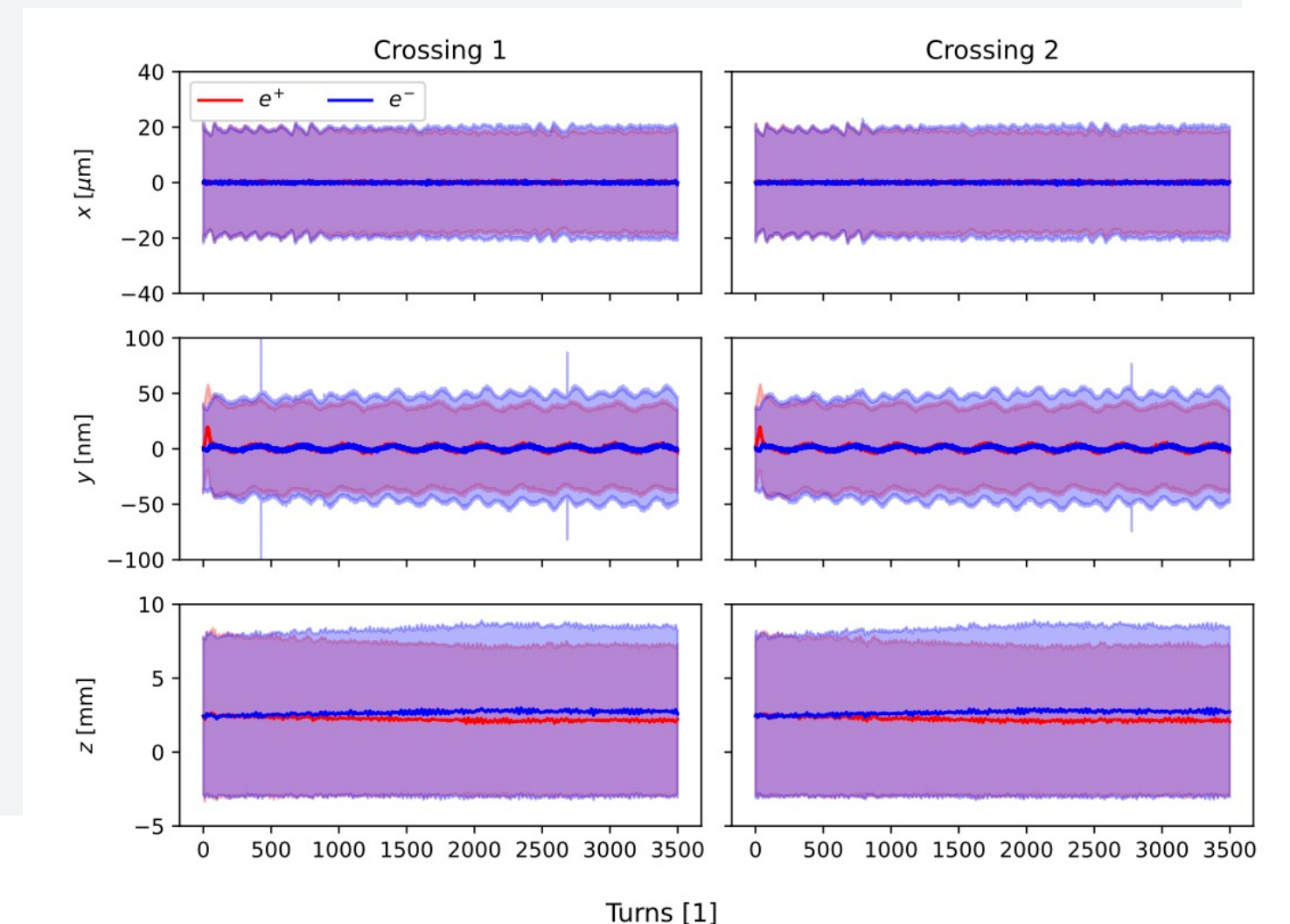

FCCee Main Ring BPMs

Emily Howling PhD (Philip Burrows, Marek Gasior)



UNIVERSITY OF
OXFORD



~ 10,000 arc BPMs! \Rightarrow cost effectiveness

Design specs must take account of differing beam parameters vs. operating energy

Button BPM: optimising button geometry

Pickup layout must accommodate synchrotron radiation winglets in beampipe

CST simulated voltage output (time domain wake)
+ impedance (frequency domain)

\Rightarrow Thesis will be submitted in 2026

Parameter	Requirement
orbit resolution	0.1 μm
turn by turn resolution	< 10 μm
arc BPM accuracy	20 μm
signal processing time	< 25 ns

Mode	Z	W	ZH	$t\bar{t}$
Energy, GeV	45.6	80	120	182.5
Bunch intensity, 10^{11}	2.14	1.45	1.15	1.55
Bunch charge, nC	34.3	23.2	18.4	24.8
rms bunch length with SR/BS, mm	5.6/15.5	3.5/5.4	3.4/4.7	1.8/2.2
Number of bunches/beam	11200	1780	440	60
Bunch spacing, ns		25		
Beam current, mA	1270	137	26.7	4.9

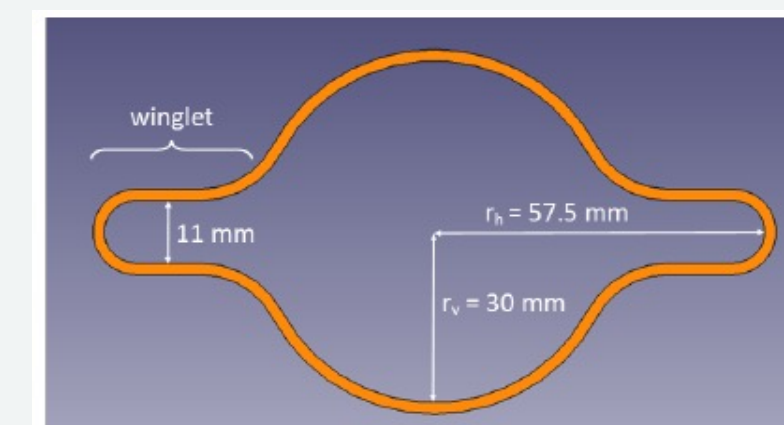

FCCee Main Ring BPMs

Emily Howling PhD (Philip Burrows, Marek Gasior)



UNIVERSITY OF OXFORD



Nominal design developed. Initial thermal studies show high heating ~200 C max – design iteration will continue to improve this.

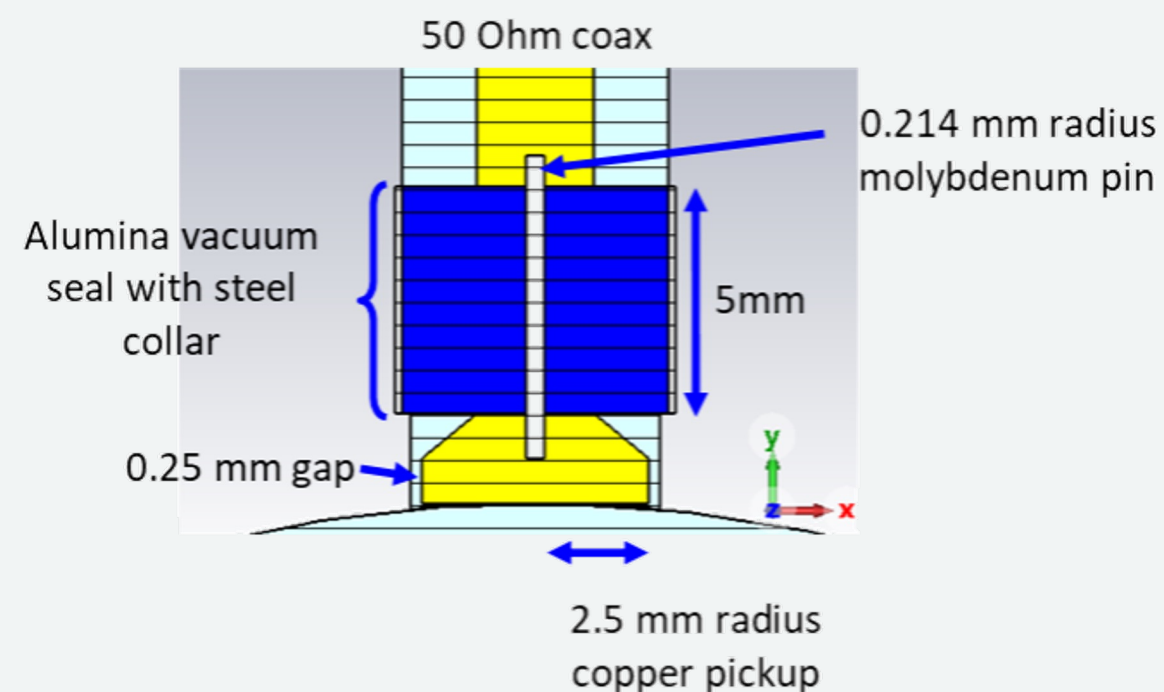

Fig 1: A cross-section of the CST model of the current nominal pickup design.

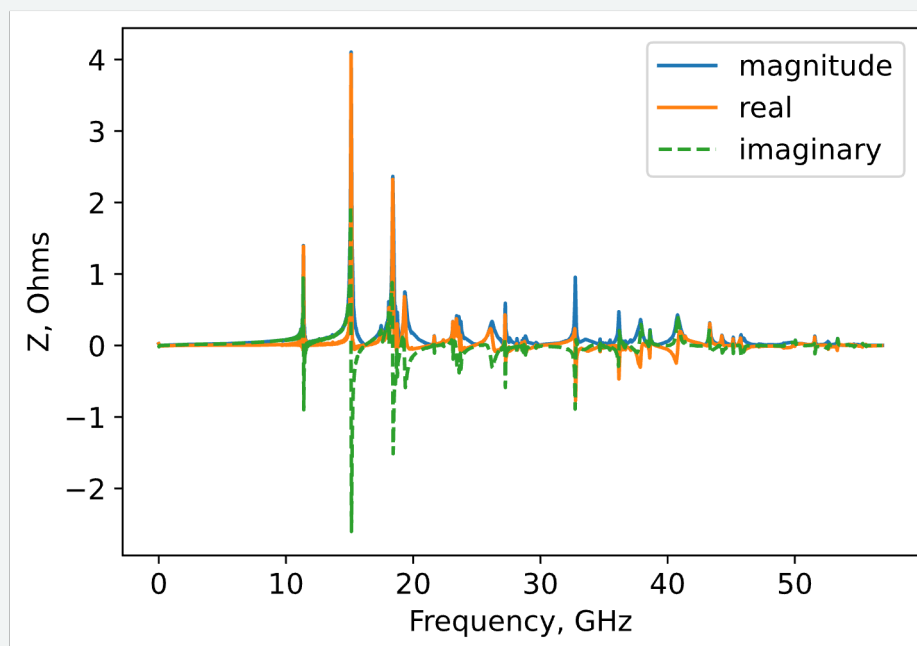

Fig 2: Wake impedance spectrum for nominal design, simulated in CST.

Non-standard geometries studied with CST simulation show promise, particularly elliptical button.

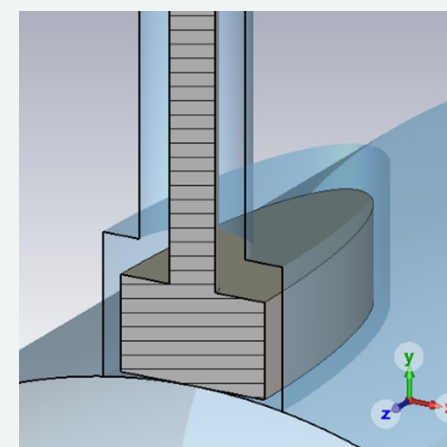

Fig 3: Elliptical button with ratio 4 modelled in CST, sliced at z=0.

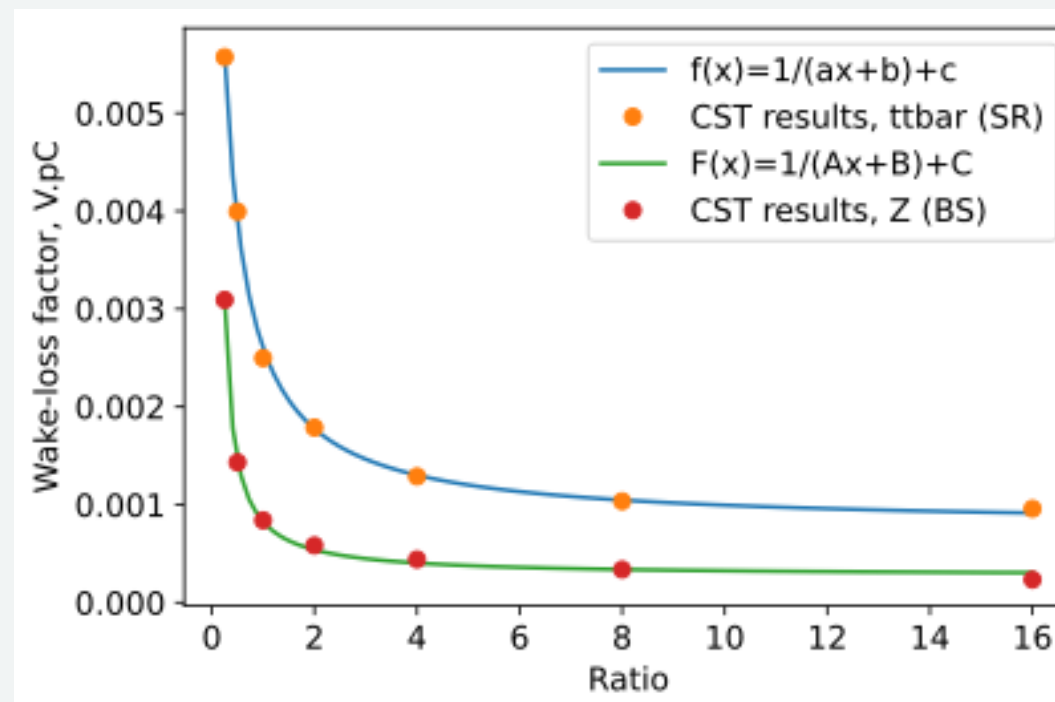

Fig 4: Wake loss factors for different ratio elliptical buttons for two different FCCee operational modes, simulated in CST.

Benchmarking studies of existing BPMs at AWAKE, CLEAR and SwissFEL have informed estimates of performance in reality, given simulation results.

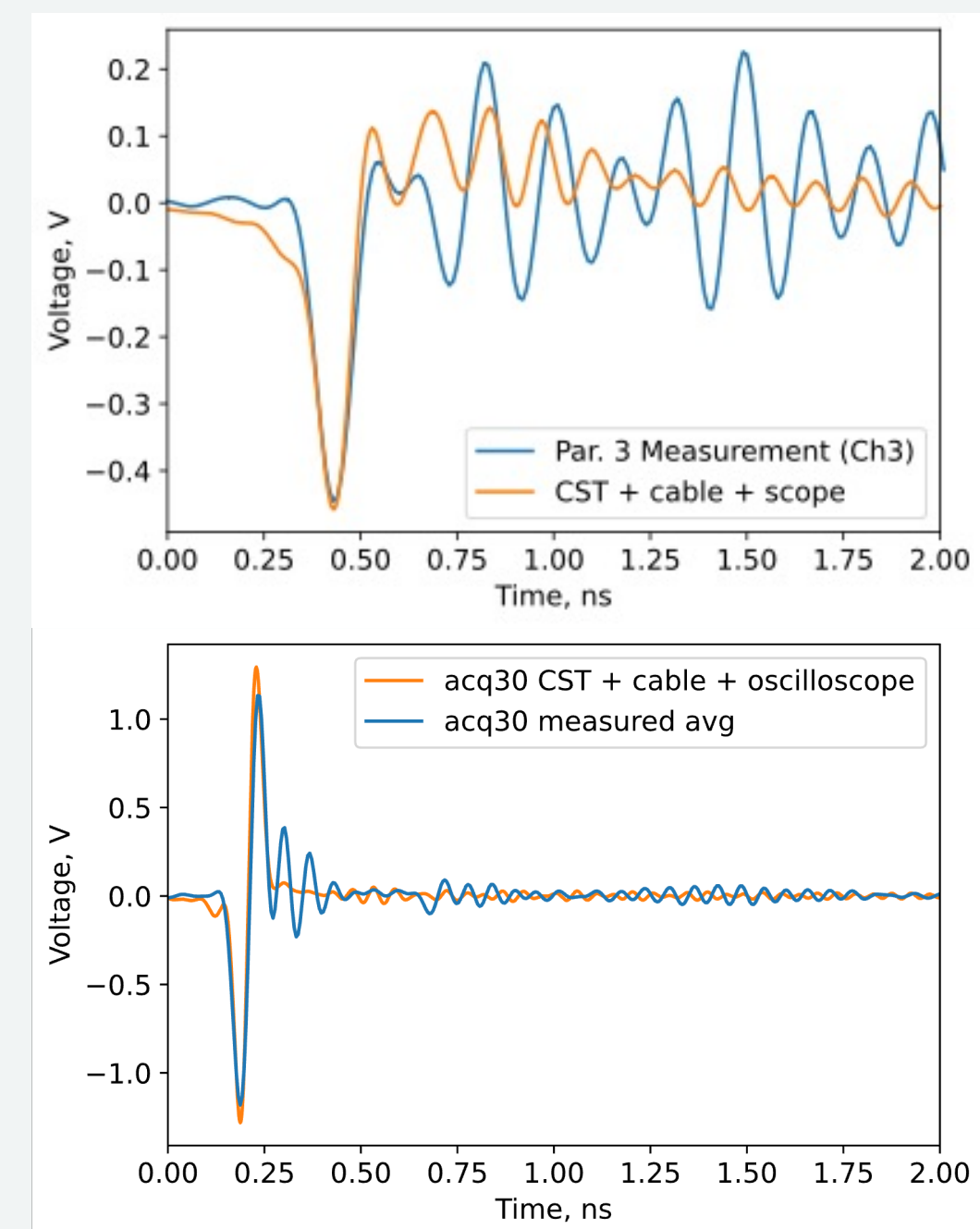
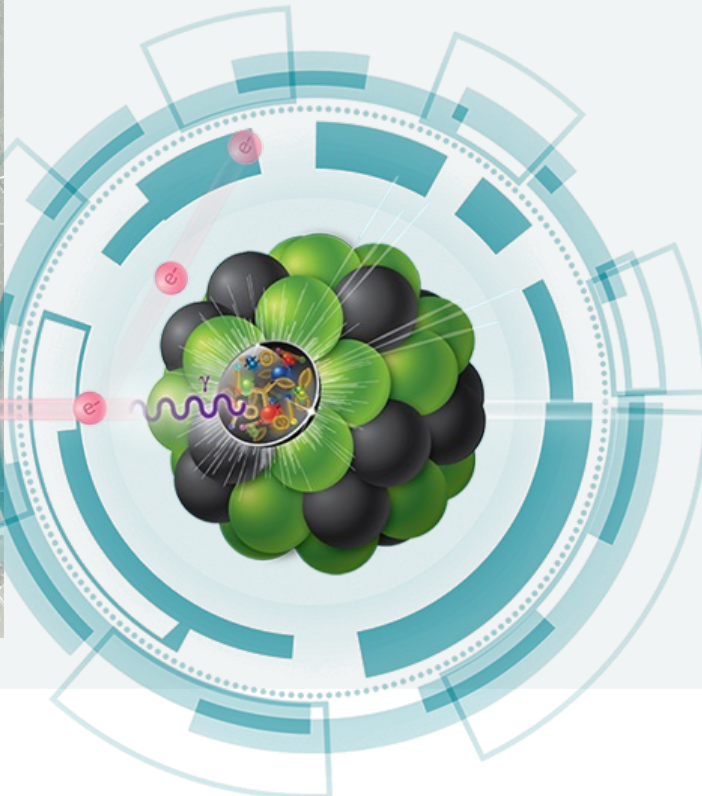
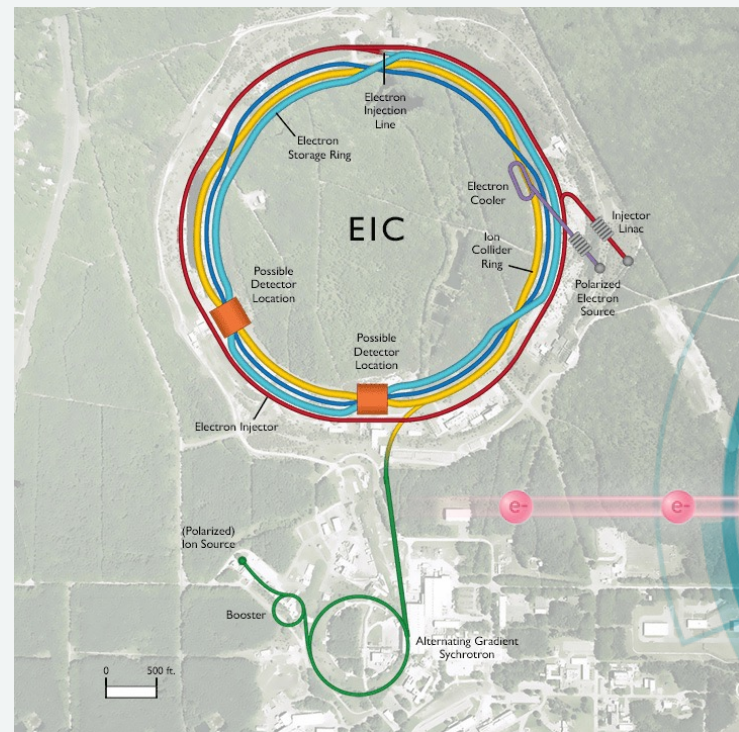

Fig 5: Example benchmarking measurement and simulation results of LHC BPM at CLEAR (top) and PSI broadband pickup at SwissFEL (bottom).



3. More Colliders and Fixed-Target Facilities

EIC



Coherent Stability + Beam Lifetime @GSI/FAIR



Adrian Oeftiger & GSI/FAIR collaborators

Facility for Antiproton and Ion Research @GSI campus (DE):

- Soon to deliver p^+ .. U28+ beams for fundamental physics
- Collective effects \rightarrow major limit for heavy-ion operation!
- New: established single-bunch stability in FAIR SIS100
 - JAI presented talk at IPAC'25, Taipei (TW): [10.18429/JACoW-IPAC2025-THAN2](https://doi.org/10.18429/JACoW-IPAC2025-THAN2)
 - \Rightarrow **Developed complete 6D high-fidelity simulation model** including the lattice, detailed apertures, self-consistent space charge and beam-coupling impedance
- Developed octupole scheme for Landau damping of coupled-bunch instabilities with strong space charge at sufficient Dynamic Aperture
 - presented at IPAC'25 and HB'25, Huizhou (PCR)

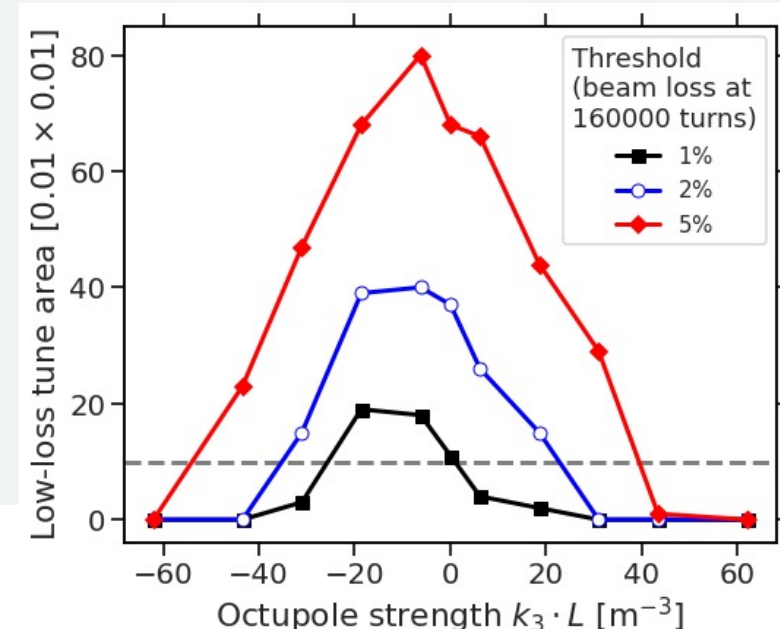
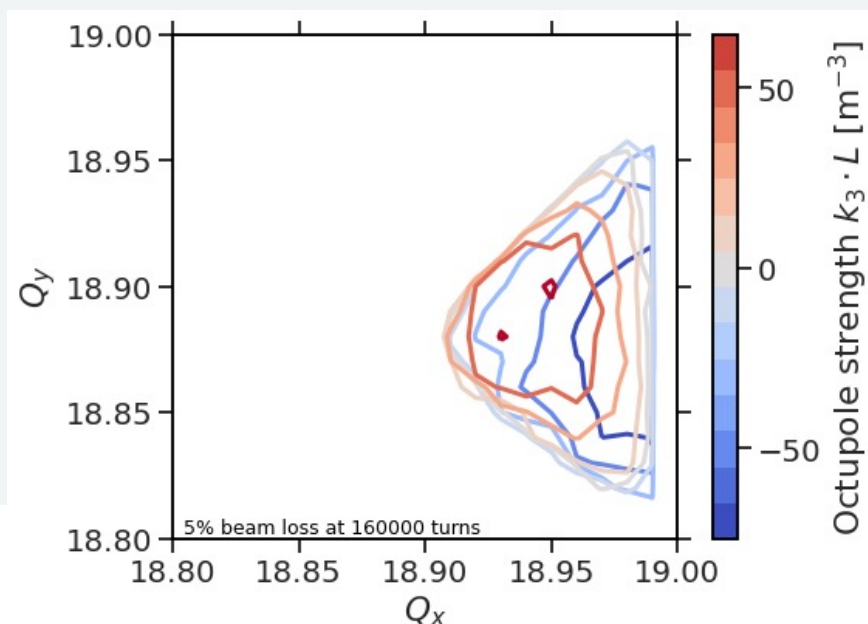
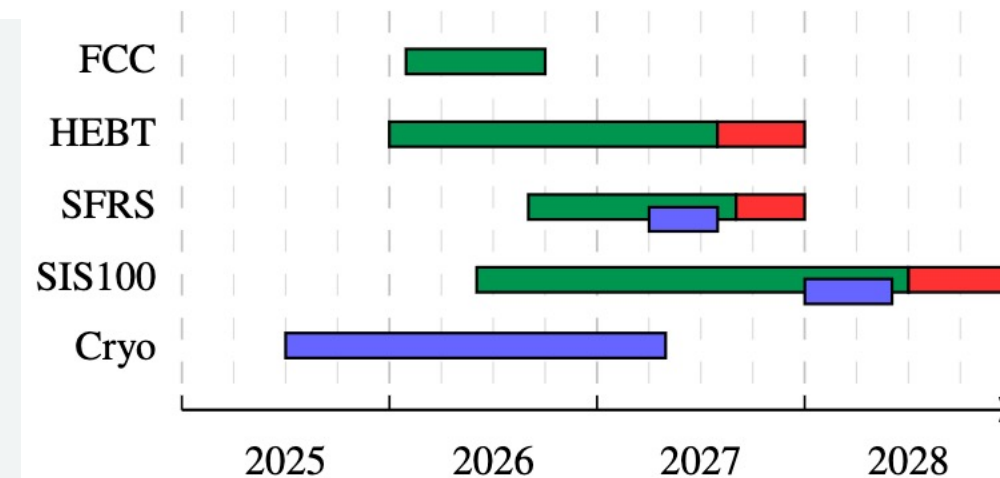
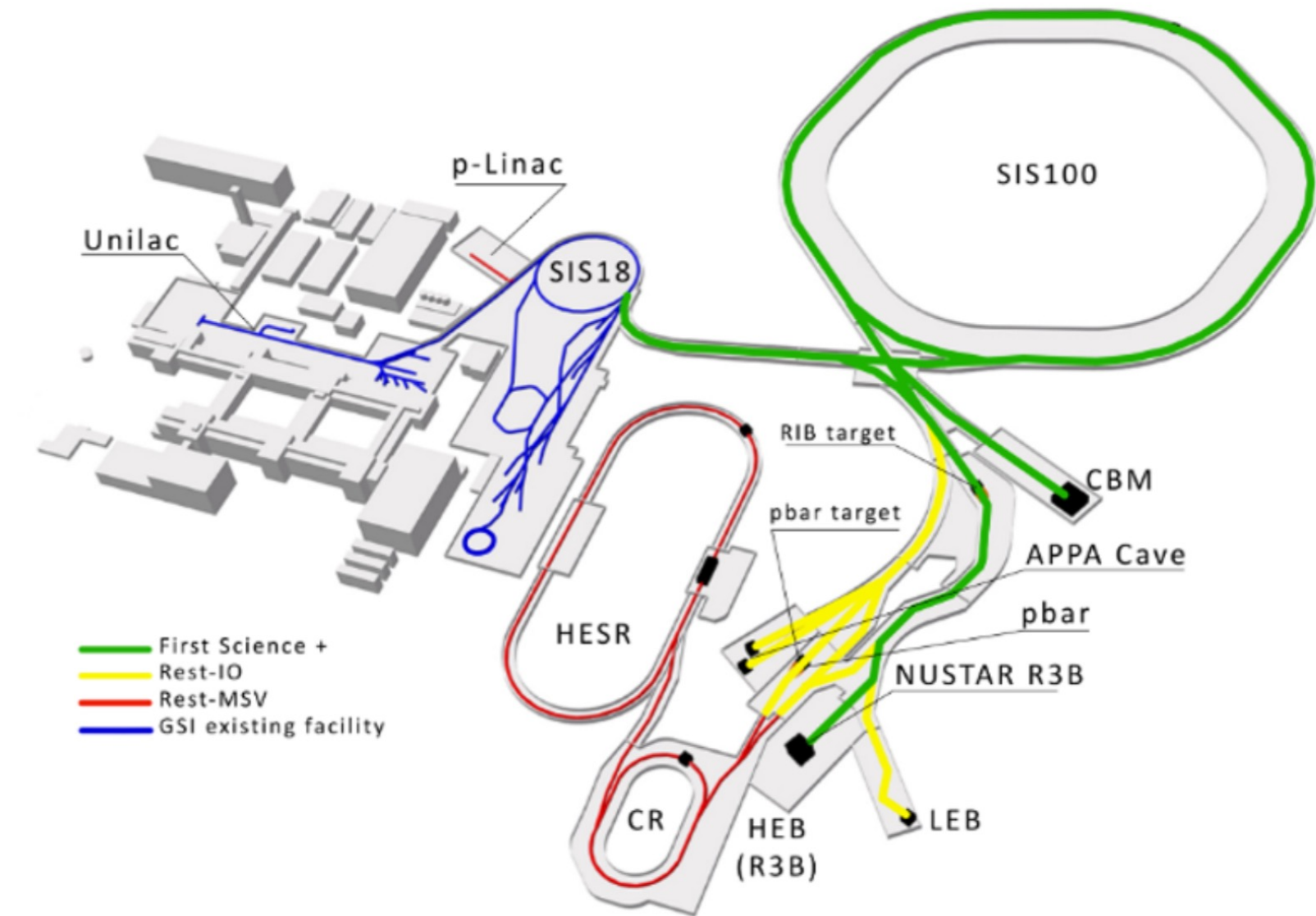

16th International Particle Accelerator Conference, Taipei, Taiwan
 ISBN: 978-3-95450-248-6 ISSN: 2673-5490 doi: 10.18429/JACoW-IPAC2025-THAN2

COHERENT STABILITY AND DYNAMIC APERTURE WITH STRONG SPACE CHARGE FOR THE FAIR SIS100 SYNCHROTRON

A. Oeftiger*, John Adams Institute, University of Oxford, UK
 V. Kornilov, GSI Helmholtz Centre for Heavy Ion Research, Darmstadt, Germany



Data-driven Modelling and Uncertainty

Adrian Oeftiger & TU Darmstadt collaborators



Need for accelerator models with uncertainty quantification:

- Important for Digital Twins, high-fidelity **simulation** models, accurate accelerator **control**, active-learning driven **design**, ...
 - New results in collaboration with TU Darmstadt (Victoria Isensee): Development of **physics-informed Gaussian Process** kernel model
 - Presented at IPAC'25, Taipei (TW): [10.18429/JACoW-IPAC2025-THPM017](https://doi.org/10.18429/JACoW-IPAC2025-THPM017)
- ⇒ **Enables sample-efficient Bayesian Optimisation approaches** to establish accelerator models

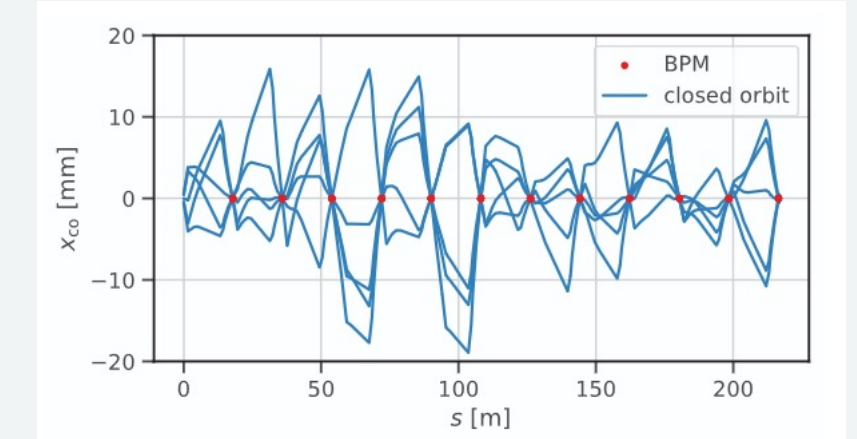

Many accelerator setups: different global orbit distortions (blue), indistinguishable in measurements (zero orbit at red points)

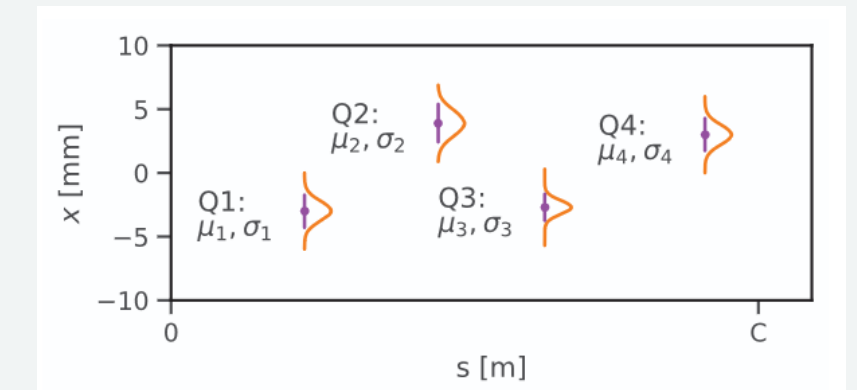

Physics-informed Gaussian Process model intrinsically includes uncertainty via distributed degrees of freedom (e.g. misaligned quadrupoles)

Plans:

- 2027: Kick off EC-funded (10 MEur) **TwinRise** project on Digital Twins (from accelerators to medical applications)
- New JAI PDRA (TwinRise) to start in 2027: develop physics-informed beamline/accelerator twins

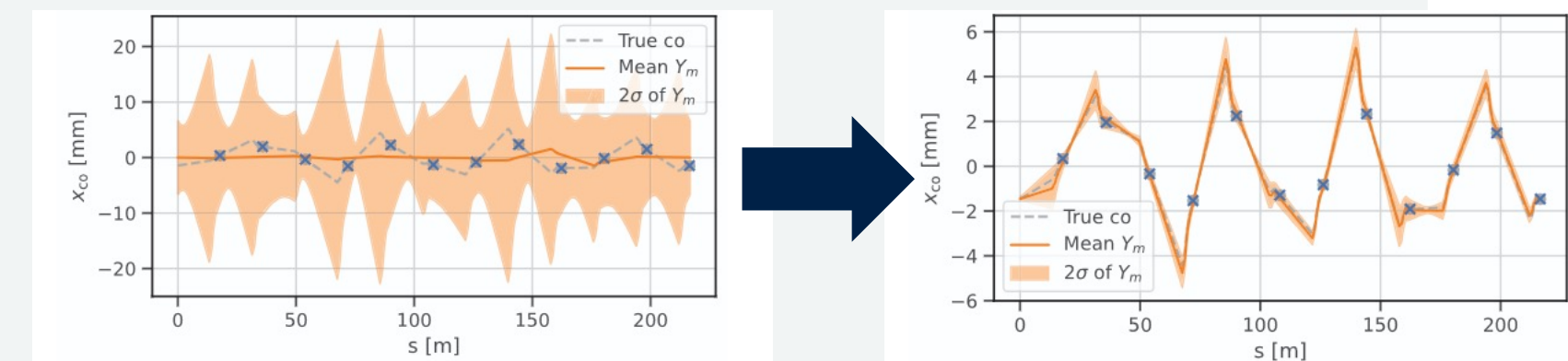

Bayesian Optimisation to establish uncertainty-quantified accelerator model with high sample efficiency



16th International Particle Accelerator Conference, Taipei, Taiwan
ISBN: 978-3-95450-248-6 ISSN: 2673-5490 doi: 10.18429/JACoW-IPAC2025-THPM017

**UNCERTAINTY-QUANTIFIED MACHINE MODEL CONSTRUCTION
USING PHYSICS-INFORMED GAUSSIAN PROCESSES AND
BAYESIAN OPTIMIZATION**

V. Isensee*, O. Boine-Frankenheim¹, TEMF, Technical University Darmstadt, Darmstadt, Germany
A. Oeftiger, John Adams Institute, University of Oxford, Oxford, UK

Coherent Stability @EIC

Adrian Oeftiger & Mike Blaskiewicz (BNL)



Electron-Ion Collider @BNL campus (US):

- Deep inelastic scattering with proton/ion beams, currently under construction
- Cooling → key element for performance
 - Requires low momentum spread, low RF voltage ⇒ slow synchrotron motion
 - Small vertical beam size (10x smaller emittance than horizontal plane)
 ⇒ **Coherent stability** with strong space charge becomes a central issue
- JAI contributes detailed simulation studies to develop beam stabilisation schemes to mitigate emittance growth

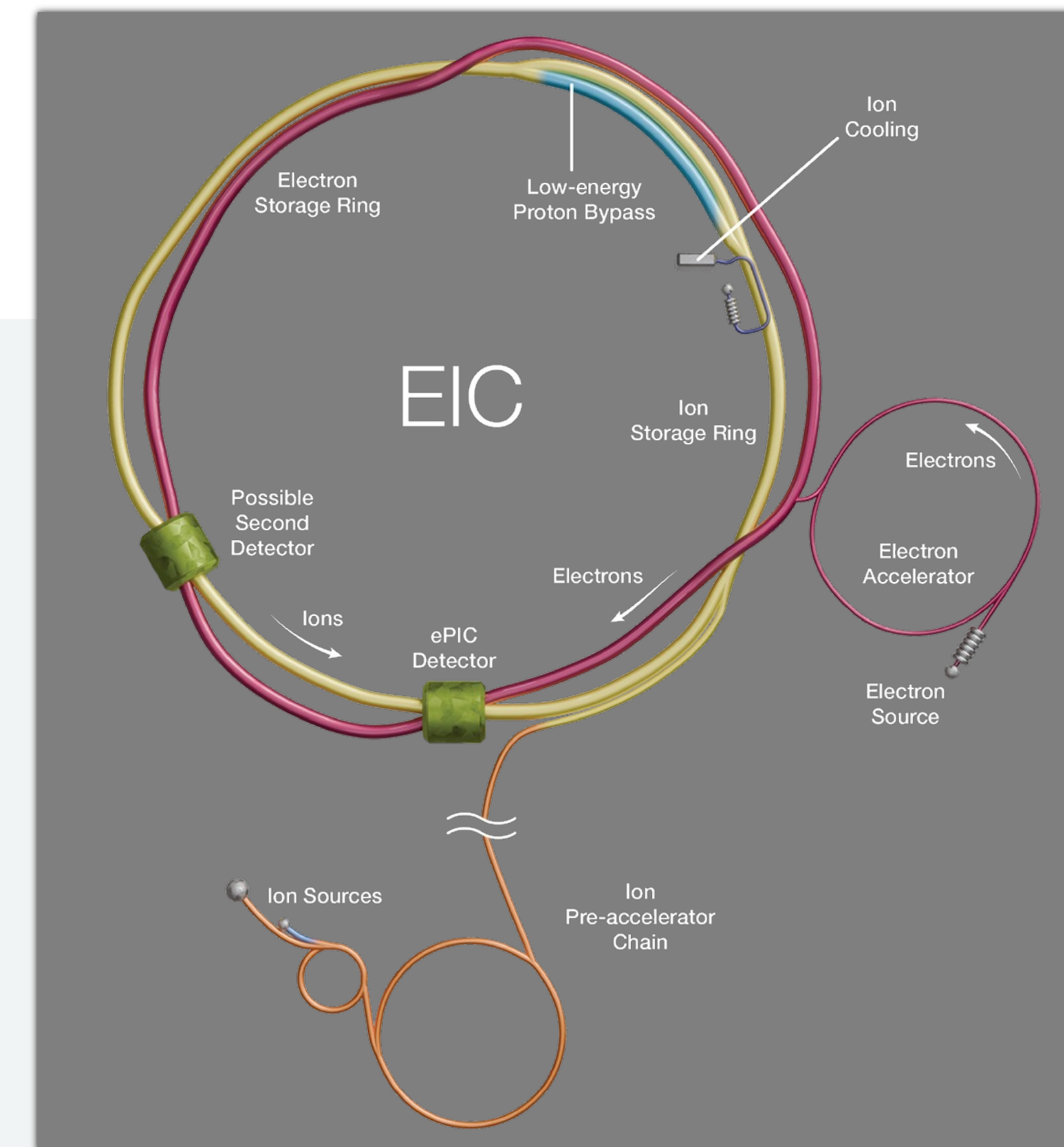

EIC project timeline

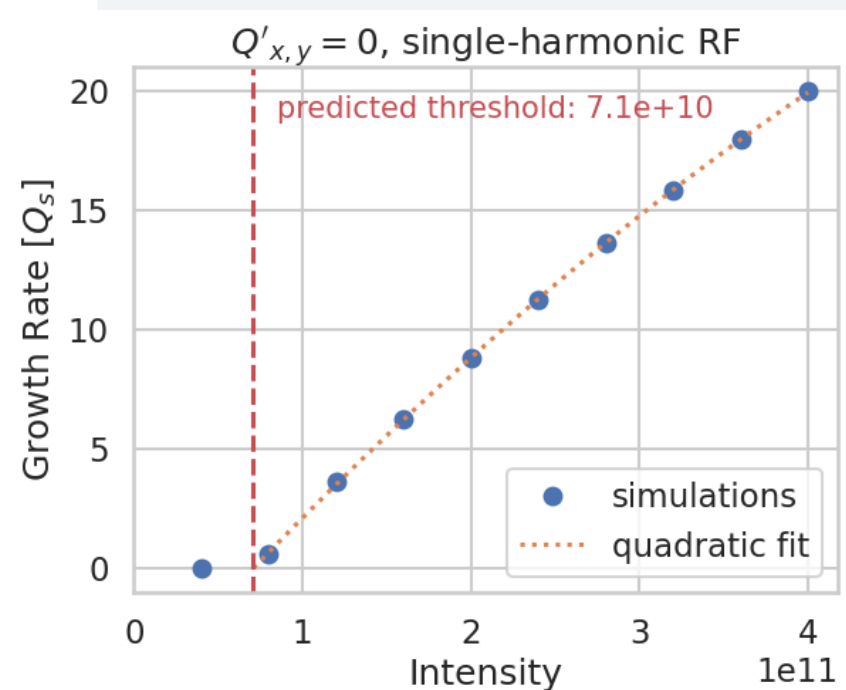
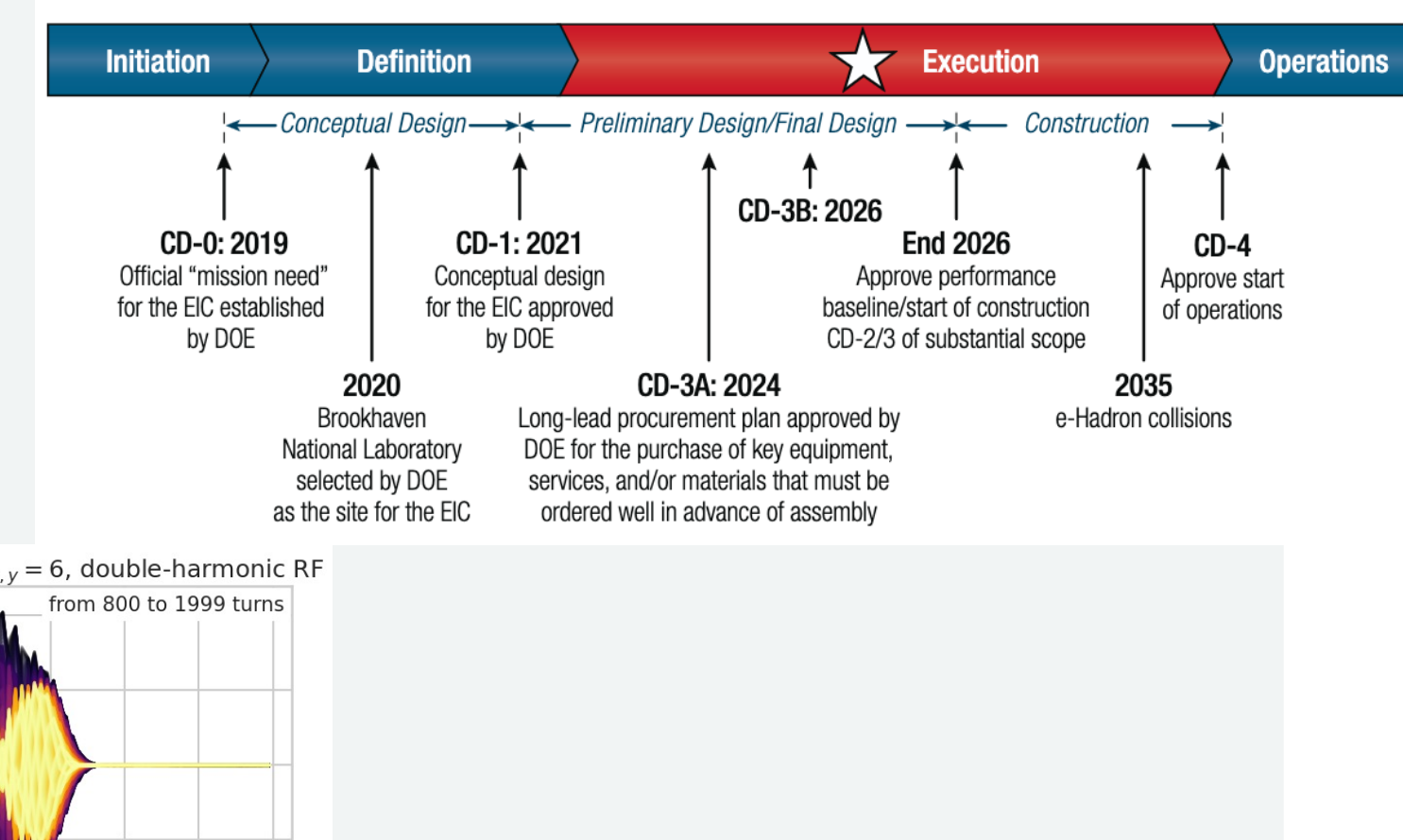

Parameter scans characterising unstable behaviour in simulations

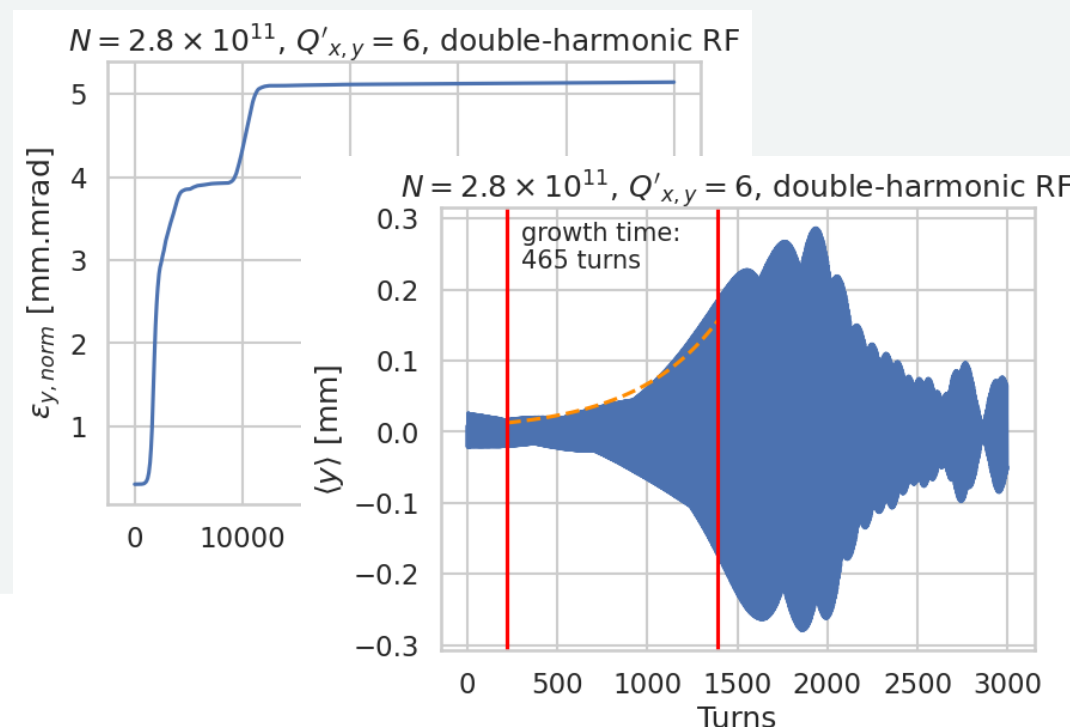
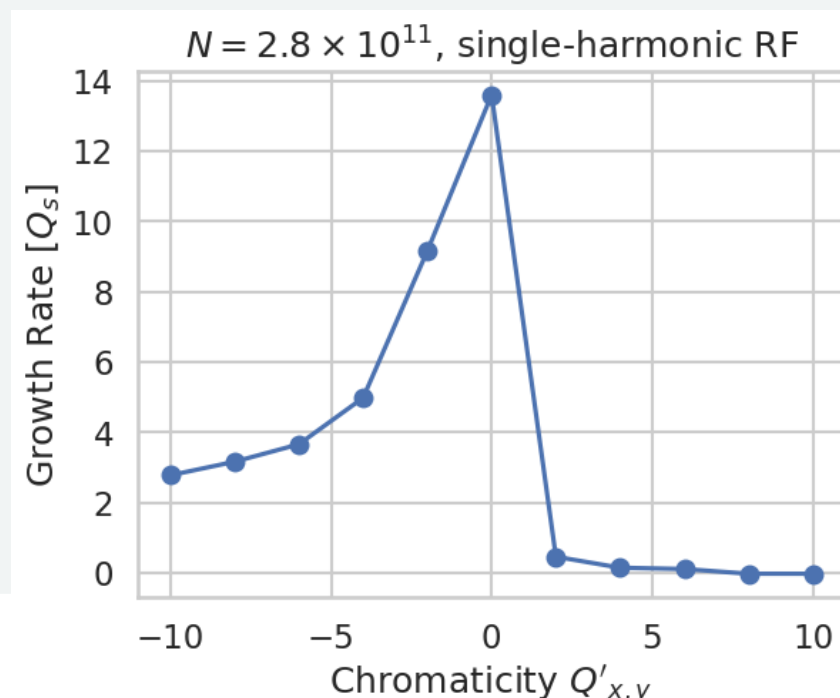

Example of fast instability, 10x emittance growth

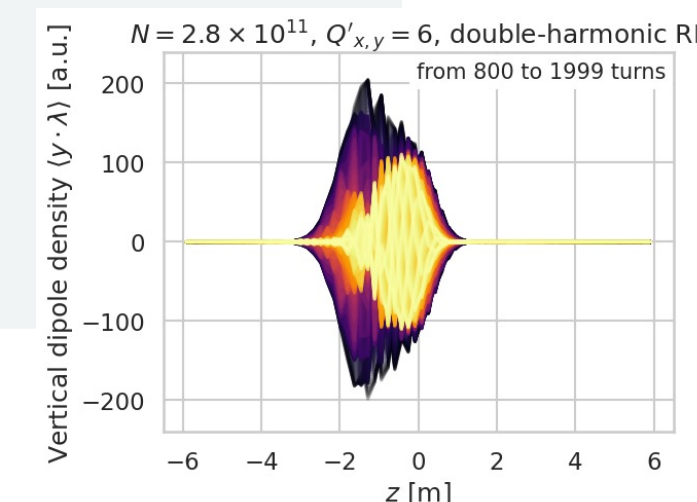

Simulated intra-bunch motion during instability



Funded by the European Union

Muon Collider developments

- UK contributing to MuCol WP4 Muon Production & Cooling (led by Chris Rogers, RAL) and WP8 Cooling cell Integration.
- Paul Jurj and Rohan Kamath are applying BDSIM to model a baseline lattice design for 6D cooling.
- New cooling lattice (Jurj et al) and cell design

nuSTORM:
Preparation of realistic fluxes and synthetic beams will be in Kamath's thesis.

Parameter	Unit	Value	
Cooling Cell Length	mm	800	
Beam Physics			
Momentum	MeV/c	200	
Twiss beta function	mm	107	
Dispersion in X	mm	38.5	
Dispersion in Y	mm	20.3	
Beam Pipe Radius	mm	81.6	
Solenoid Parameters			
	Unit	Value	Tol
B0	T	8.75	0.25
B0.5	T	0	0.02
B1	T	1.25	0.025
B2	T	0	0.5
Coil Geometry			
Inner Radius	mm	250	
Length	mm	140	
Radial Thickness	mm	169.3	
Z Centre Position	mm	100.7	
Current Density	A/mm ²	500	
RF Cavity			
Center-to-center distance	mm	188.6	
Gradient E0	MV/m	30	
Iris Radius	mm	81.6	
Number of RF Cells		3	
Frequency	GHz	0.704	
Synchronous Phase	degree	20	
Window Thickness	mm	0.1	
Wedge			
Material		LiH	
Opening Angle	degree	10	
Thickness	mm	20	
Alignment		Horizontal	
Dipole			
Length	mm	100	
Polarity		+ - - +	
Field	T	0.2	
Z Centre Position	mm	160	
Field Direction		Vertical	

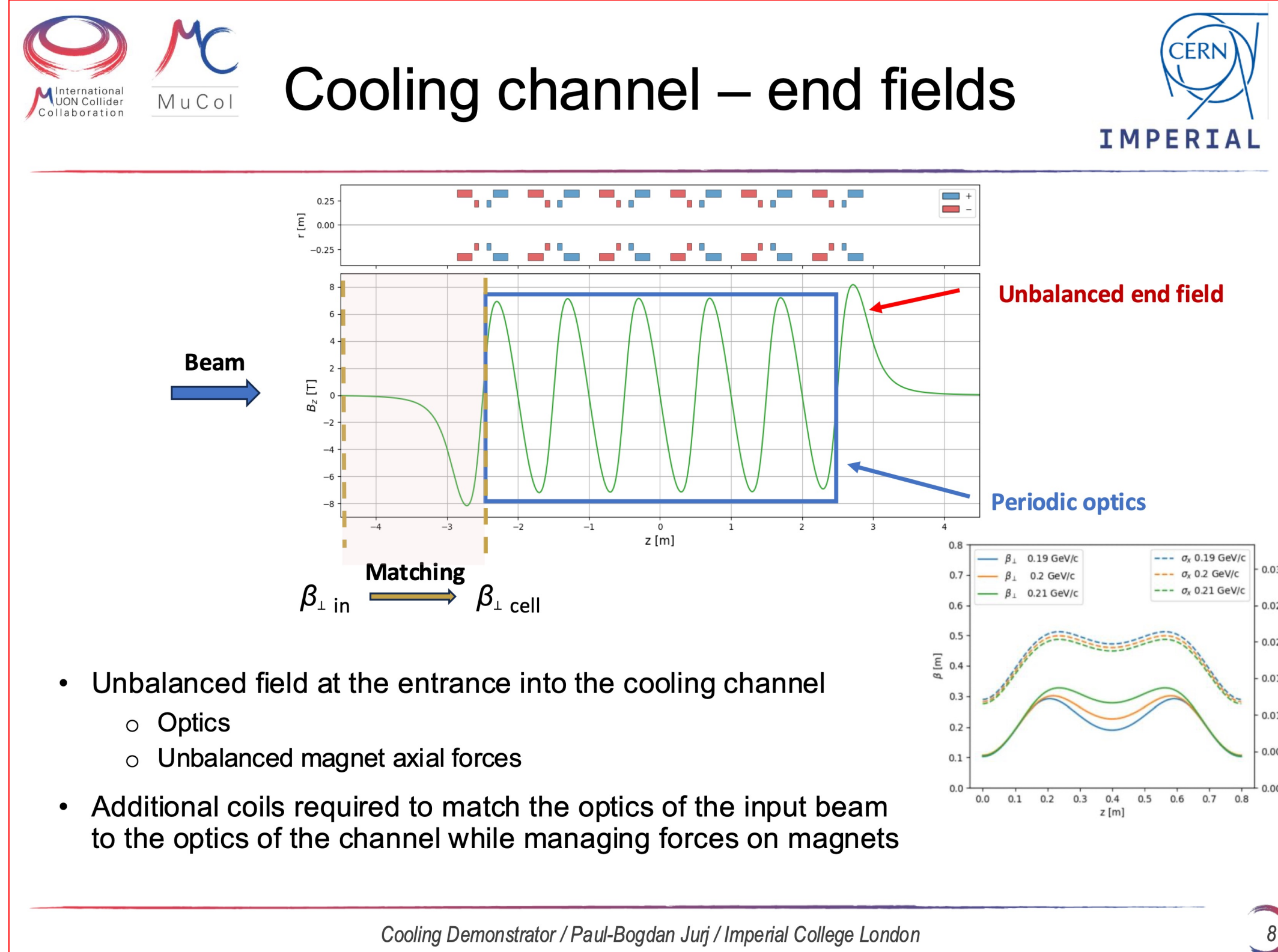
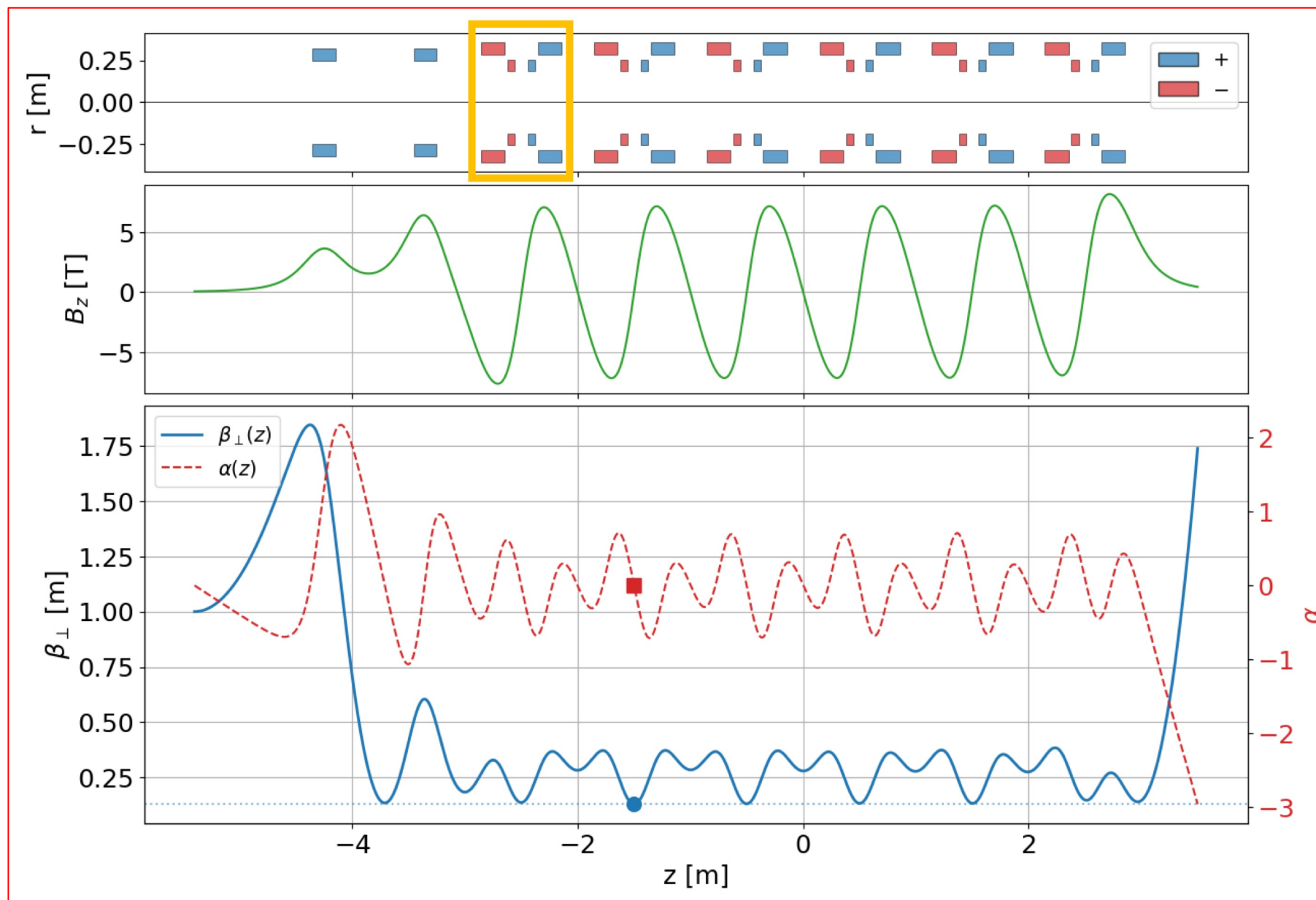

- Unbalanced field at the entrance into the cooling channel
 - Optics
 - Unbalanced magnet axial forces
- Additional coils required to match the optics of the input beam to the optics of the channel while managing forces on magnets

Summary & Outlook

- JAI active in technology pillars of EU accelerator strategy & accelerator roadmaps
- Major collaborative UK effort on HL-LHC project continues, with multiple contributions on beam diagnostics, machine protection, beam dynamics and data-driven modelling.
- BDSIM is proving useful for mission critical studies of muon flux at FASER, and a growing Physics Beyond Colliders programme.
- JAI expertise in beam dynamics & diagnostics also applied on FCC developments
- UK leading muon cooling channel design & simulations, building on historic efforts.

⇒ *JAI is making key contributions to future colliders and beamlines!*

