



# **muses** for neutron stars

Veronica Dexheimer



# ★ Original muses team

## PI and co-Pis

1. Nicolas Yunes; UIUC; **PI**
2. Jacquelyn Noronha-Hostler; UIUC; co-PI
3. Jorge Noronha; UIUC; co-PI
4. Claudia Ratti; UH; co-PI and **spokesperson**
5. Veronica Dexheimer; KSU; co-PI

## Senior investigators

1. Roland Haas; NCSA UIUC
2. Timothy Andrew Manning; NCSA UIUC
3. Andrew Steiner; UTK
4. Jeremy Holt; TA&M
5. Gordon Baym; UIUC
6. Mark Alford; WU
7. Elias Most; PU

## External collaborators



We have 224+ collaborators

We have 123+ NS collaborators

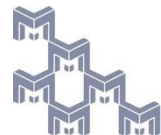

# ★ QCD phase diagram status

- \* Current input from different (first-principle and effective) theories and experiments
  - lattice QCD
  - perturbative QCD
  - chiral effective field theory
  - heavy-ion collisions
  - low-energy nuclear physics
  - observations of neutron stars

*Living Rev.Rel.* 27 (2024) 1, 3  
e-Print: [2303.17021](https://arxiv.org/abs/2303.17021) [nucl-th]

- binary neutron star mergers coming soon...

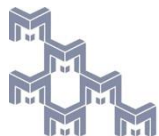
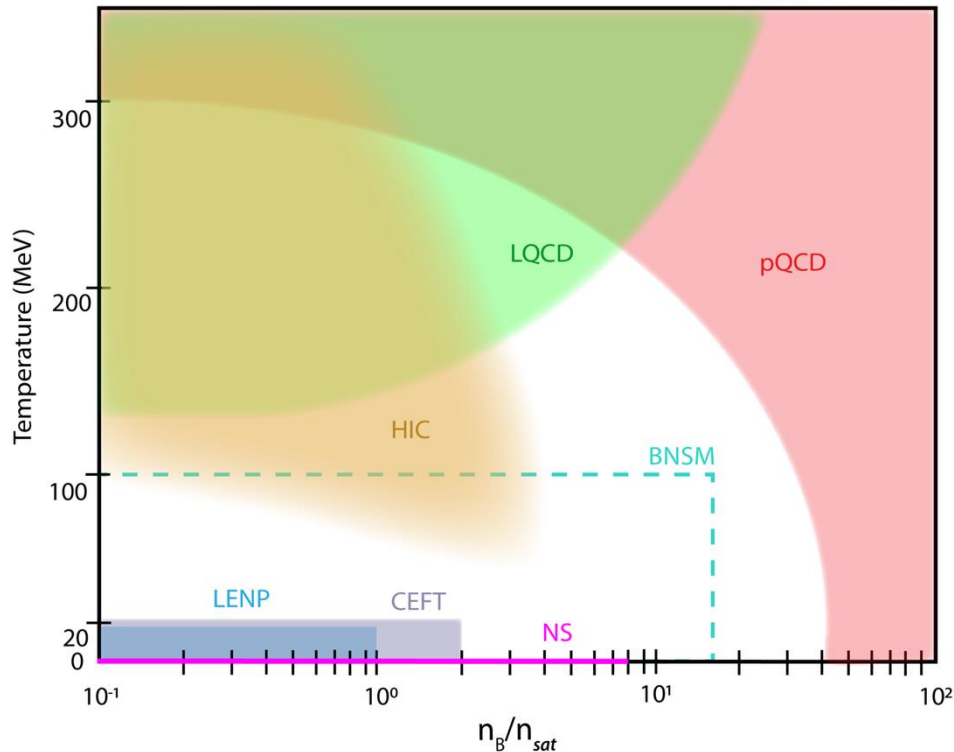

# ★ **muses** beta release (February 2025)

EoSs

- \* We publicly released the alpha release modules (Sep 2024)
- \* We invited everyone to test these modules and provide feedback
- \* Included a first set of modules (free and open-source)

- finite T
- ✓ BQS EOS: 4D lattice QCD with alternative expansion scheme in  $\mu_B$
  - ✓ ISING-TEXS EOS: 2D Critical behavior into lattice QCD alternative expansion
  - ✓ NUMRELHOLO: 2D AdS/CFT correspondence based EoS

- $T \sim 0$
- ✓ CMF: 3D Chiral EoS with baryon octet, decuplet, and quarks
  - ✓ CEFT: 2D EoS with nucleons
  - ✓ UTK or Crust DFT: 2D EoS with nucleons and nuclei
  - ✓ Lepton module, Synthesis module, CompOSE outputs (interpolator)

# ★ Chiral Mean Field (CMF)

- ★ Microscopic relativistic mean-field model with chiral symmetry restoration and quark deconfinement

*Phys.Rev.C* 81 (2010) 045201 e-Print: [0901.1748](https://arxiv.org/abs/0901.1748)

- ★ Reproduces liquid-gas, and crossover/1st-order phase transition for deconfinement

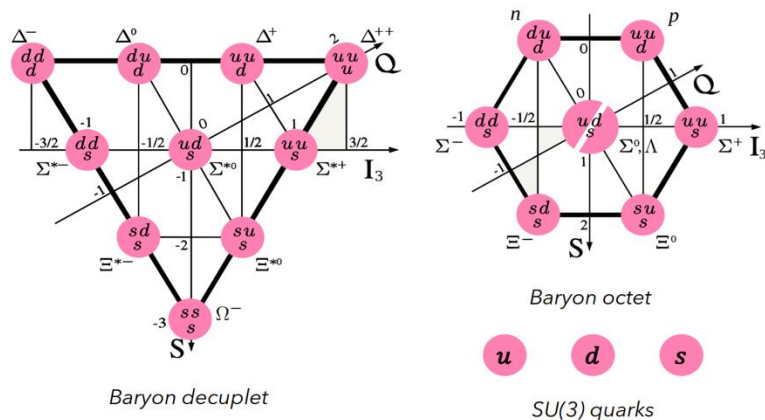
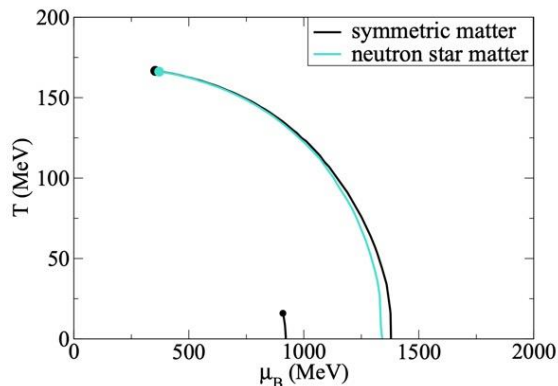

- ★ In agreement with nuclear physics, astrophysics, and lattice QCD
- ★ MUSES CMF++ released in 3D ( $\mu_B$ ,  $\mu_Q$ ,  $\mu_S$ ) and  $T=0$  with 4 vector coupling options

*Phys.Rev.D* 111 (2025) 9, 094030  
e-Print: [2409.06837](https://arxiv.org/abs/2409.06837)

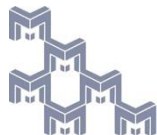



- \* Optimized and documented new 3D (T=0) CMF code

*Phys.Rev.D* 111 (2025) 9, 094030  
e-Print: [2409.06837](https://arxiv.org/abs/2409.06837)

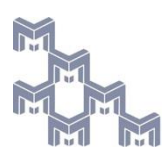
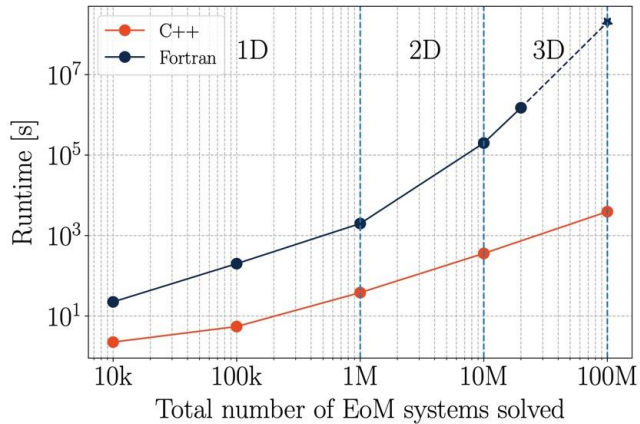



- \* Optimized and documented new 3D (T=0) CMF code

*Phys.Rev.D* 111 (2025) 9, 094030  
 e-Print: [2409.06837](https://arxiv.org/abs/2409.06837)

- a) chiral condensate
- b) deconfinement field  $\Phi$
- c) strangeness fraction
- d) charge fraction
- e) baryon density
- f) speed of sound squared with high order susceptibilities

C3 octet + decuplet + quarks ( $\mu_S \neq 0, \mu_Q = -200$  MeV)

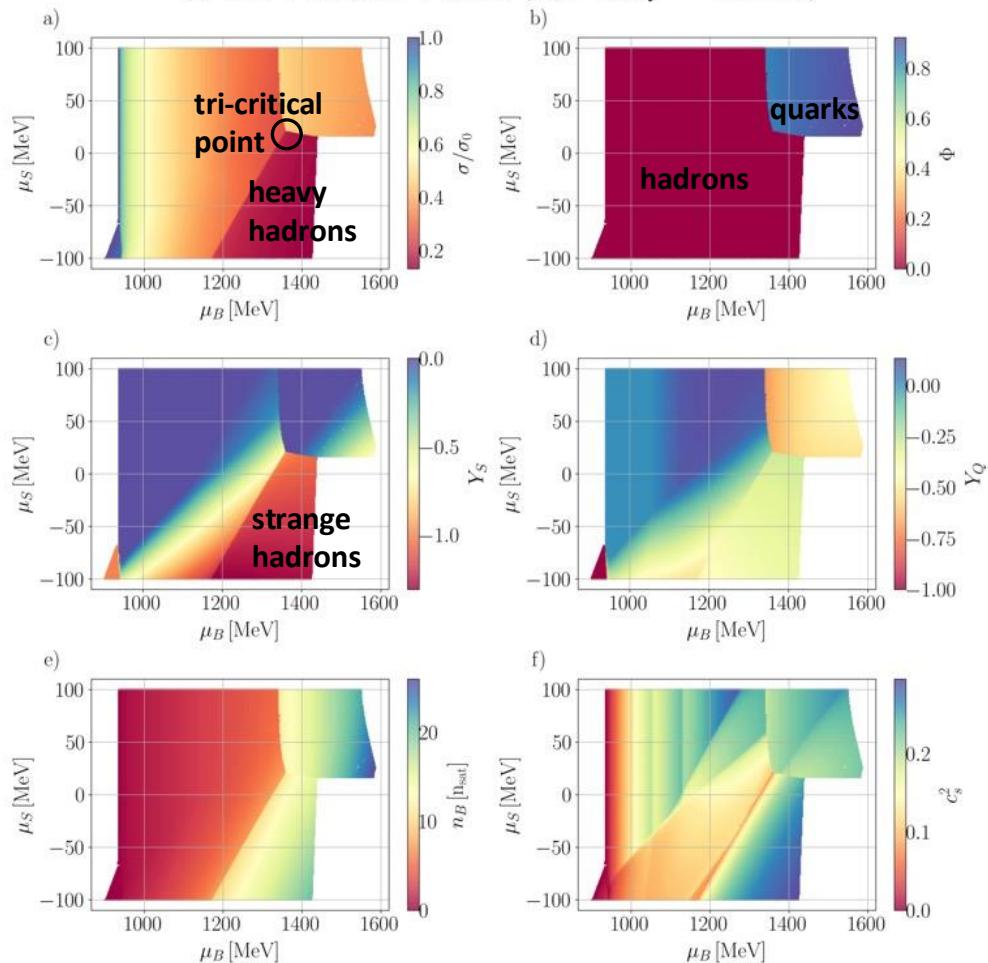

# ★ Muses $\chi$ EFT

- ★ Ab-initio EoS computed up to N3LO in many-body perturbation theory (with three-body forces up to N2LO)

*Phys.Rev.C* 95 (2017) 3, 034326

e-Print: [1612.04309](https://arxiv.org/abs/1612.04309)

- ★ Interacting nucleons in 2D
- ★ Fitted to nucleon scattering data and bound state potentials
- ★ Applicable for  $n_B \lesssim 2n_{\text{sat}}$
- ★ Released in 2D and T=0 in MUSES

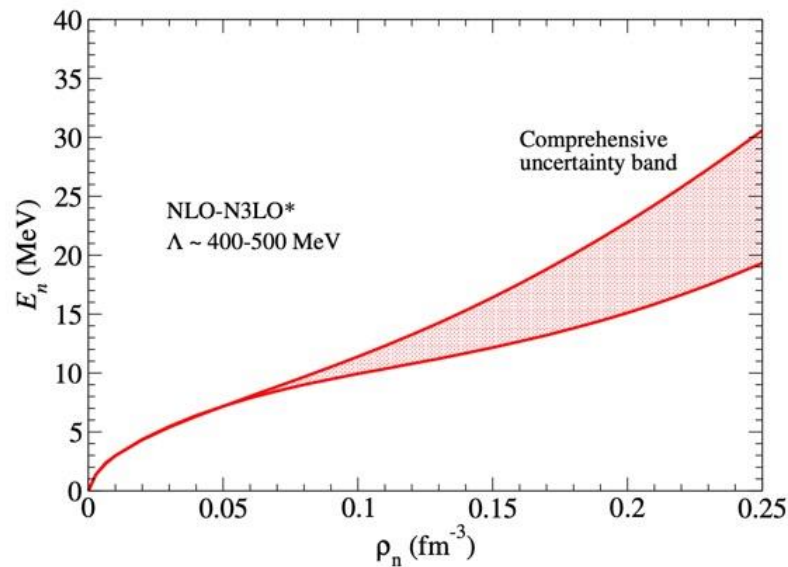

Theoretical uncertainty estimate for the neutron matter equation of state from chiral effective field theory, including errors arising from the convergence in many-body perturbation theory, missing terms in the chiral expansion, and choice of resolution scale.

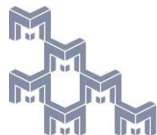

# ★ M **muses** Crust-DFT or UTK

- \* Includes interacting nucleonic degrees of freedom and an ensemble of nuclei
- \* EoS based on a phenomenological fit of free energy density to nuclear experiments and astronomical observations

*Phys.Rev.C* 105 (2022) 3, 035803

e-Print: [2107.06697](https://arxiv.org/abs/2107.06697)

*Phys.Rev.C* 99 (2019) 2, 025803

e-Print: [1802.09710](https://arxiv.org/abs/1802.09710)

- \* Guided by many-body theory calculations
- \* Released in 2D and  $T \sim 0$  in MUSES

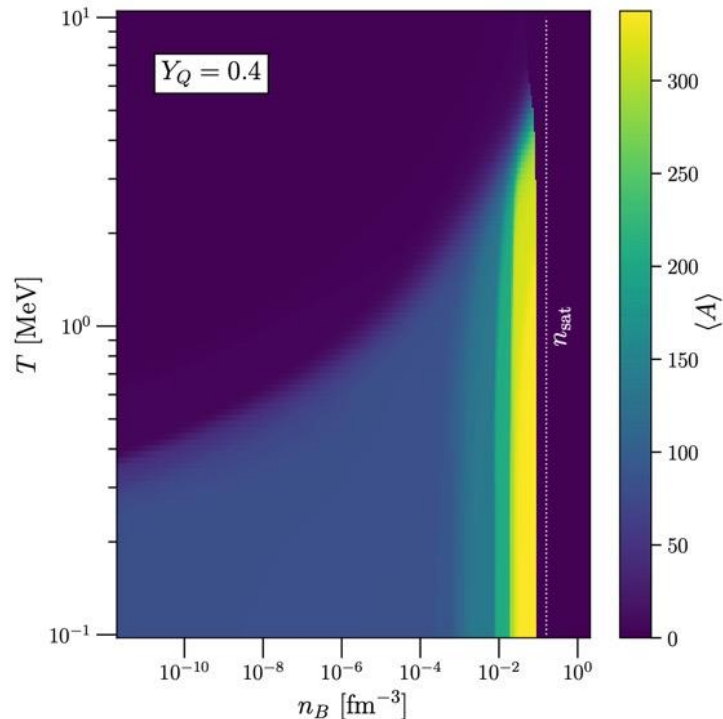

Average nuclear mass number  $\langle A \rangle$ , see Eq. (2), as a function of density and temperature at a fixed charge fraction  $Y_Q = 0.4$  calculated within Crust-DFT. The value of  $n_{\text{sat}}$ ,  $0.16 \text{ fm}^{-3}$ , is just above the density at which  $\langle A \rangle$  drops sharply to zero.

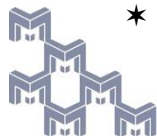

# ★ **muses** Lepton module

\* Pure lepton EoS:  $e, \mu, \tau, \nu$

\* Leptons added for charge neutrality  $\sum_{i \in B} n_i Q_i + \sum_{i \in l} n_i Q_i = 0$ ,

\* Leptons added for charge neutrality and  $\beta$ -equilibrium ( $-\mu_Q = \mu_e$ )

\* Fixed lepton fraction

$$Y_l = \frac{n_l}{n_B} = \frac{\sum_{i \in l} n_i}{\sum_{i \in B} n_i}$$

\* Charge neutrality can also be global (mixed phase)

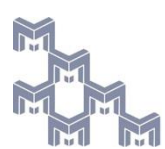

★ Pure lepton EoS:  $e, \mu, \tau, \nu$

★ Leptons added for charge neutrality  $\sum_{i \in B} n_i Q_i + \sum_{i \in l} n_i Q_i = 0$ ,

★ Leptons added for charge neutrality and  $\beta$ -equilibrium ( $-\mu_Q = \mu_e$ )

★ Fixed lepton fraction

$$Y_l = \frac{n_l}{n_B} = \frac{\sum_{i \in l} n_i}{\sum_{i \in B} n_i}$$

★ Charge neutrality can also be global (Gibbs construction: mixed phase)

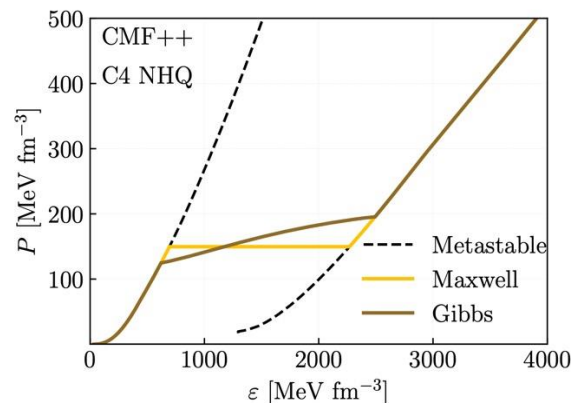

Equation of state for the CMF++ module including nucleons, hyperons and quarks. The deconfinement transition is calculated using the Maxwell (yellow) and Gibbs (brown) constructions. The dashed black curve represents metastable phases.

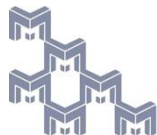

- \* First-order phase transitions (Maxwell or Gibbs constructions)
- \* Smooth matching of EoS's

$$Y(x) = Y^I(x)f_-(x) + Y^{II}(x)f_+(x),$$

with

$$f_{\pm}(x) = \frac{1}{2} \left( 1 \pm \tanh \left[ \frac{x - \bar{x}}{\Gamma} \right] \right).$$

for

- P as a function of  $\mu_B$
- $\epsilon$  as function of  $n_B$
- P as function of  $n_B$
- $c_s^2$  as function of  $n_B$

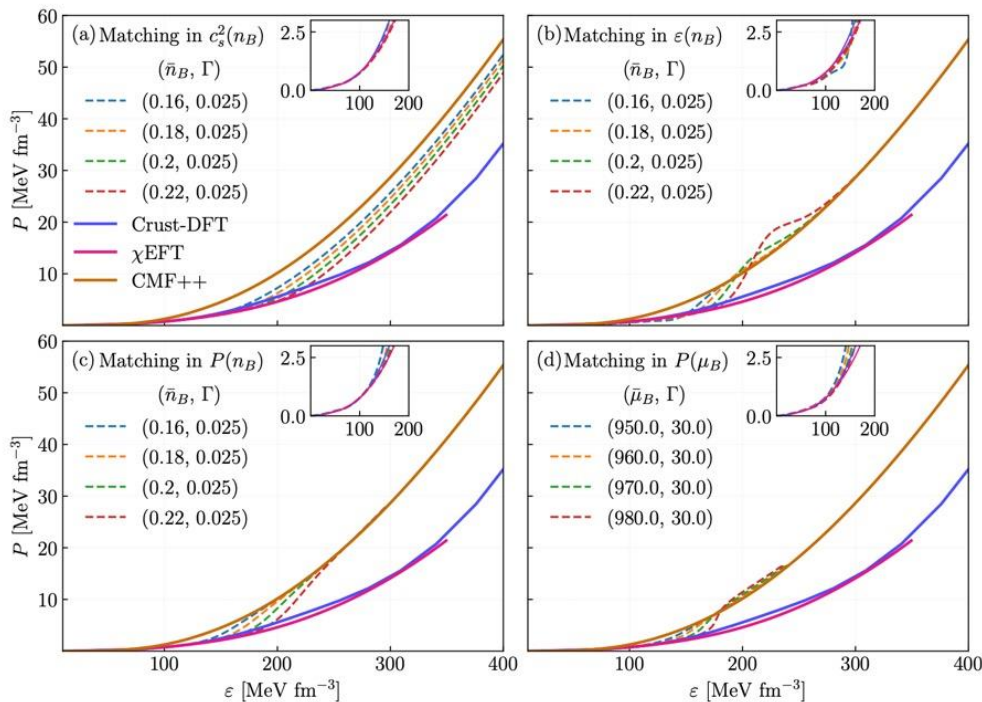

- \* First-order phase transitions (Maxwell or Gibbs constructions)
- \* Smooth matching of EoS's

$$Y(x) = Y^I(x)f_-(x) + Y^{II}(x)f_+(x),$$

with

$$f_{\pm}(x) = \frac{1}{2} \left( 1 \pm \tanh \left[ \frac{x - \bar{x}}{\Gamma} \right] \right).$$

for

- P as a function of  $\mu_B$
- $\epsilon$  as function of  $n_B$
- P as function of  $n_B$
- $c_s^2$  as function of  $n_B$

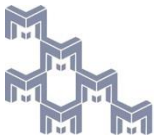
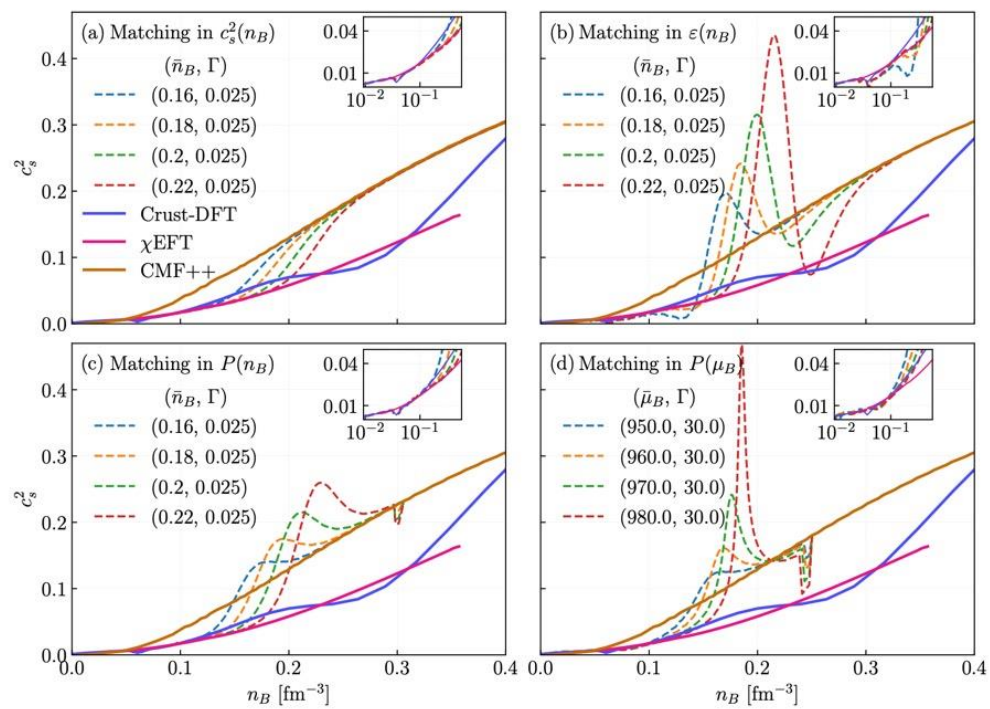

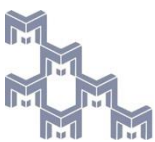
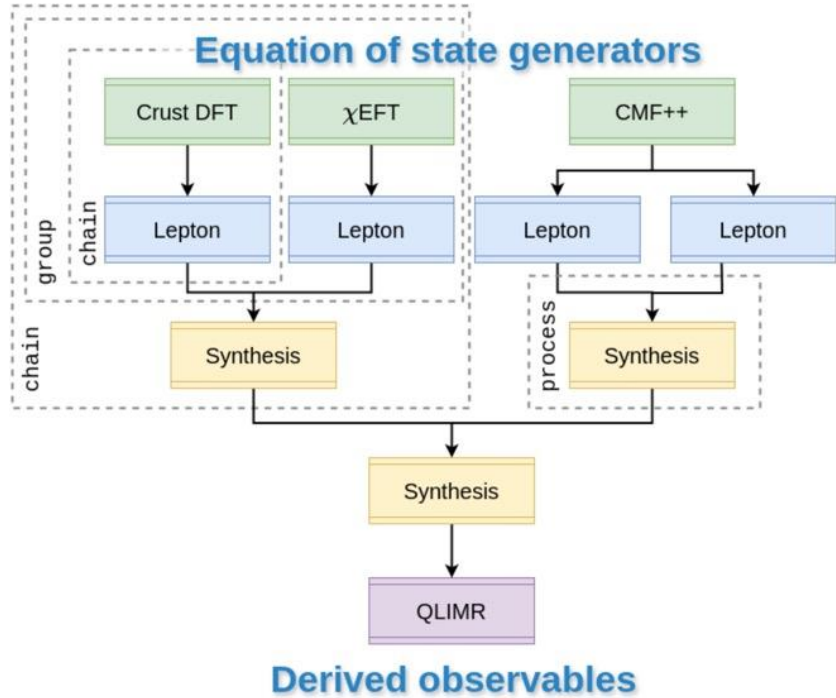
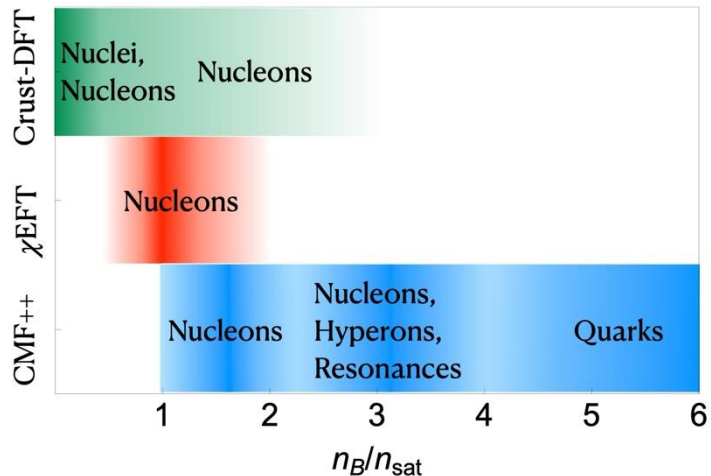

- \* We publicly released the alpha release modules (Sep 2024)
- \* We invited everyone to test these modules and provide feedback
- \* Included a first set of modules (free and open-source)

$T \sim 0$

- ✓ QLIMR module: quadrupole moment, tidal Love number, moment of inertia, mass, and radius of static and slowly rotating neutron stars (including universal relations)
- ✓ Flavor equilibration for weak  $\beta$ -equilibrium: Urca rates, relaxation rates, damping time, bulk viscosity
- ✓ Susceptibilities

*Phys.Rev.D* 90 (2014) 6, 063010  
e-Print: [1406.7587](#)

*Phys.Rev.C* 110 (2024) 5, L052801  
e-Print: [2406.13717](#)

*Phys.Rev.C* 109 (2024) 5, 055803  
e-Print: [2306.06180](#)



# ★ Results for NS's

- ★ Mass-radius
- ★ Semi-universal relations
- ★ Universal relations

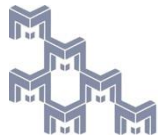
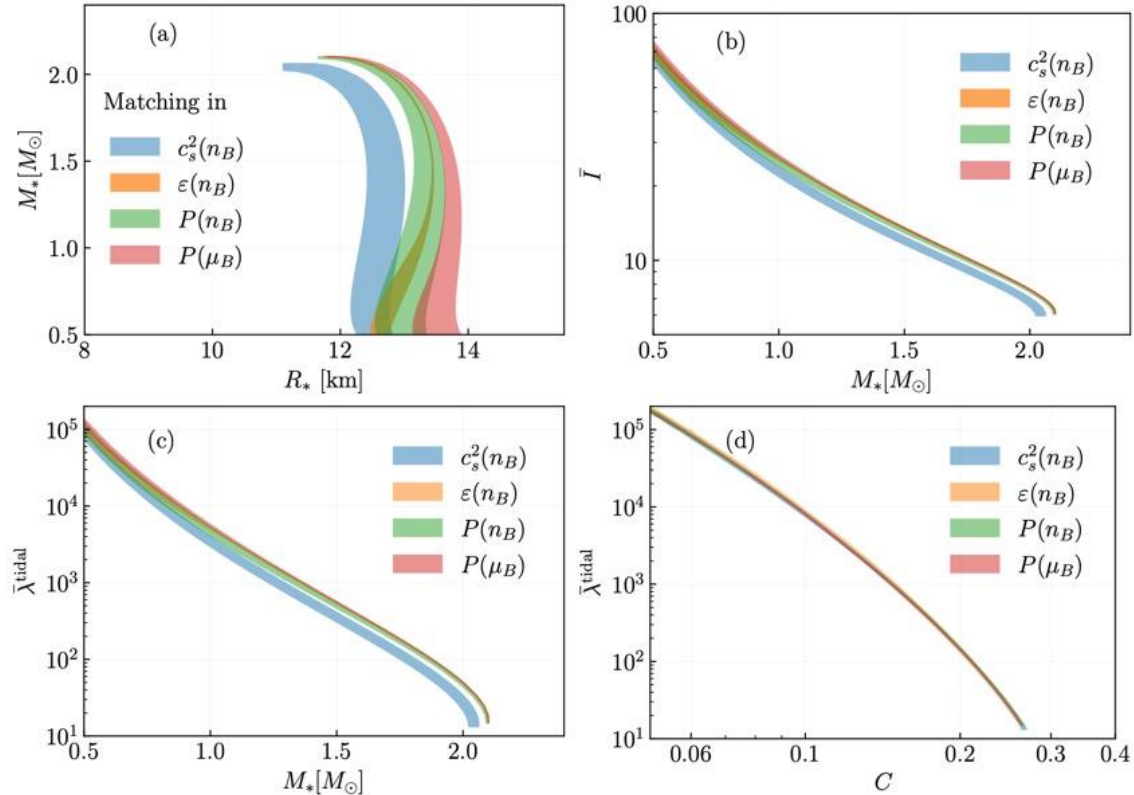

## ★ Results for a NS

- \* Crust-DFT +  $\chi$ EFT + CMF
- \* Smooth matching using speed of sound squared
- \* parameters  $\bar{n}_B = 0.065 \text{ fm}^{-3}$  and  $\Gamma = 0.01 \text{ fm}^{-3}$  between crust DFT and  $\chi$ EFT
- \* parameters  $\bar{n}_B = 0.16 \text{ fm}^{-3}$  and  $\Gamma = 0.025 \text{ fm}^{-3}$  between  $\chi$ EFT and CMF

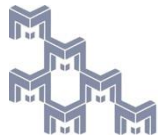
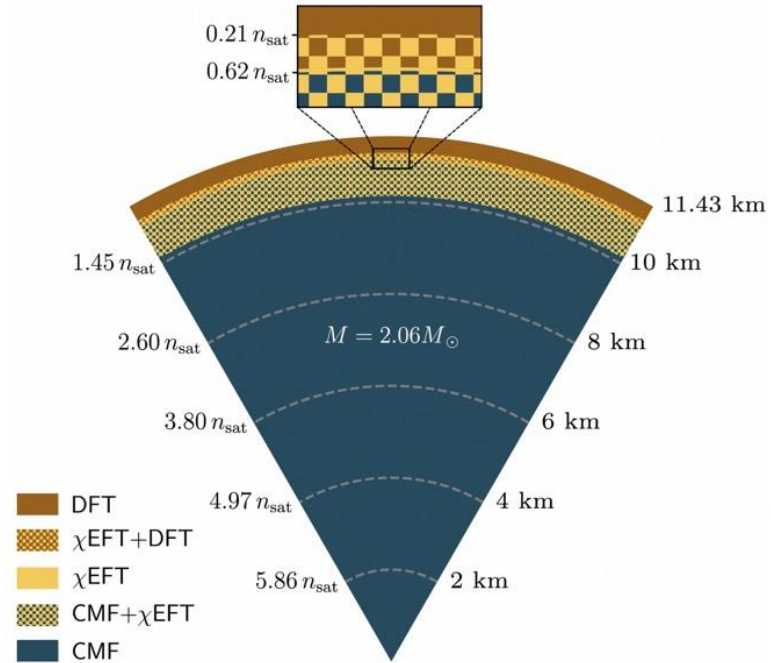

# ★ Results for a NS workflow

\*  $\chi$ EFT or CMF (no matching)

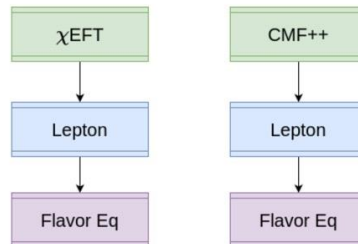

*Phys.Rev.D* 111 (2025) 10, 103037  
e-Print: [2502.07902](https://arxiv.org/abs/2502.07902)

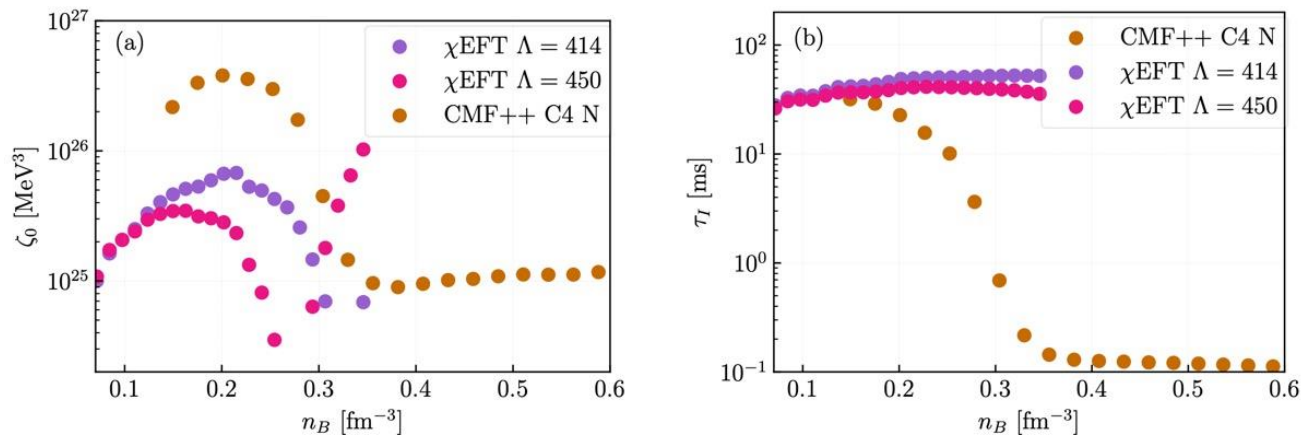

The left panel shows the static bulk viscosity, while the right panel show the isothermal flavor relaxation rate using two of the nuclear EoSs explored in this paper ( $\chi$ EFT and CMF) at a fixed temperature of  $T = 2$  MeV.

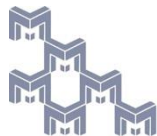

★ More interpolating functions in Synthesis at T ~ 0

- Gaussian:

$$f_-(x) = \begin{cases} 1 & \text{if } x \leq \bar{x}, \\ \exp\left[-\left(\frac{x-\bar{x}}{\Gamma}\right)^n\right] & \text{if } x > \bar{x}, \end{cases}$$

- Bump:

$$f_-(x) = 1 - \exp\left[-\left(\frac{\bar{x}}{x}\right)^n\right],$$

- Smoothstep:

$$f_-(x) = \begin{cases} 1 & \text{if } x \leq x_0 \\ 1 - 3t^2 + 2t^3 & \text{if } x_0 < x < x_1 \\ 0 & \text{if } x \geq x_1 \end{cases} \quad \text{with } t = \frac{x-x_0}{x_1-x_0},$$

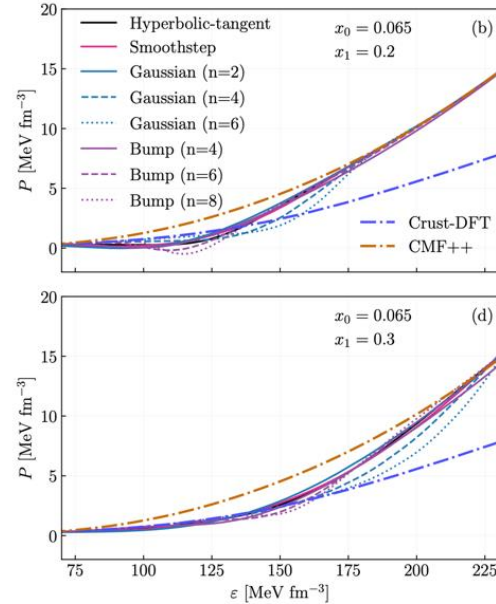

interpolations with matching done in energy density as a function of density. The top and bottom panels have different endpoints for the interpolation region. The gray dotted-dashed curve indicates the difference in energy density between the two original equations of state.

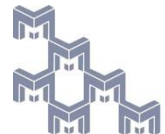

# ★ **muses** since beta release

- \* More interpolating functions in Synthesis at  $T \sim 0$
- \* CMF++: sensitivity analysis of nucleonic version performed

e-Print: [2603.16019](https://arxiv.org/abs/2603.16019) [nucl-th]

, different Polyakov parametrization added, renormalized couplings included, new general vector coupling being finalized, saturation properties being studied

- \* CMF++ at finite T:  
code completed,  
hadronic version  
connected to  
lattice QCD in 4D,  
hybrid version  
being connected  
(new fit)

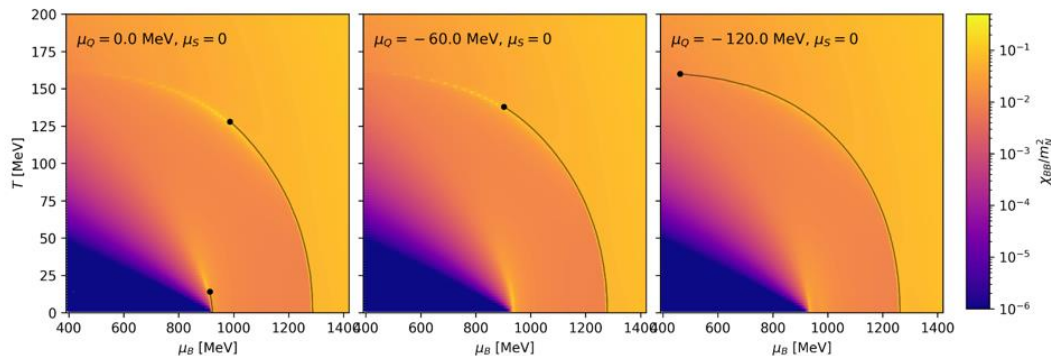

Phase diagram of the RC4 parametrization with NHQ. Color represents the second-order baryon susceptibility

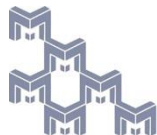

## ★ **muses** since beta release

- \*  $\chi$ EFT and craft DFT: extended to finite T, being connected with one another and also CMF
  - \* New nuclear properties module being finalized
  - \* New PQCD 3D (T=0) module finished (NLO with running s-quark mass)
- Phys.Rev.C 113 (2026) 4, 045206 e-Print: [2510.23984](#)*
- \* New Metamodel module
  - \* NS merger simulations being performed with finite  $\mu_s$
  - \* QLIMR could include in the future higher moments, dissipative tides and dynamical tides

e-Print: [2603.26886](#)

- \* NJL module completed e-Print: [2512.16720](#)

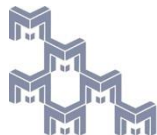

★  **muses** since beta release

- \*  $\chi$ EFT and craft DFT: extended to finite T, being connected with one another and also CMF
- \* New nuclear properties module being finalized

- \* New PQCD 3D (T=0) module finished (NLO with running s-quark mass)

*Phys.Rev.C* 113 (2026) 4, 045206 e-Print: [2510.23984](https://arxiv.org/abs/2510.23984)

Caliope

- \* New Metamodel module

- \* NS merger simulations being performed with finite  $\mu_s$
- \* QLIMR could include in the future higher moments, dissipative tides and dynamical tides

e-Print: [2603.26886](https://arxiv.org/abs/2603.26886)

- \* NJL module completed e-Print: [2512.16720](https://arxiv.org/abs/2512.16720)

