



*Knut and Alice
Wallenberg
Foundation*

Transfer-induced fission at the ISOLDE Solenoidal Spectrometer

15th Nordic Meeting on Nuclear Physics

May 5th - 8th, 2026, Visby, Gotland

Maria Vittoria Managlia

PhD student, Chalmers University of Technology



Swedish
Research
Council

Nuclear fission in the r-process

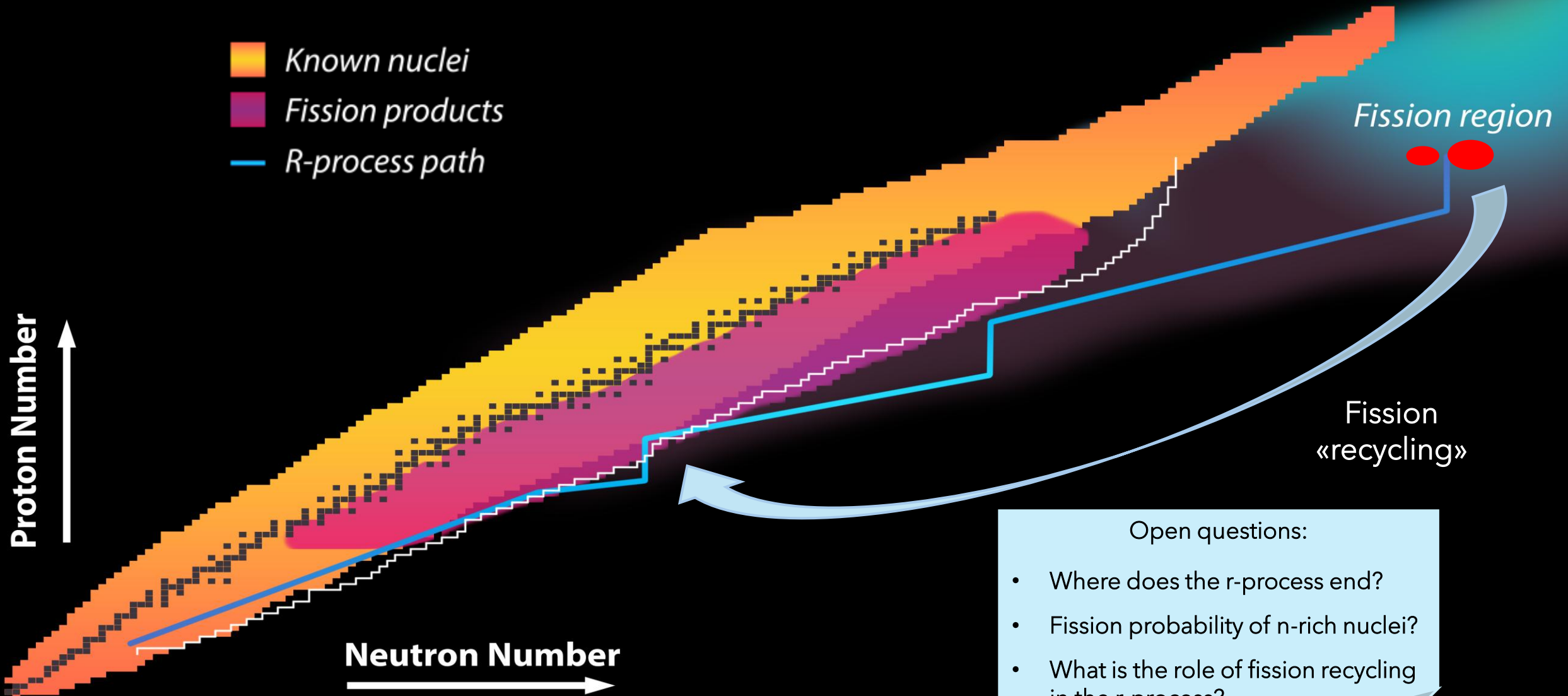

Open questions:

- Where does the r-process end?
- Fission probability of n-rich nuclei?
- What is the role of fission recycling in the r-process?



How?

The solenoidal spectrometer method

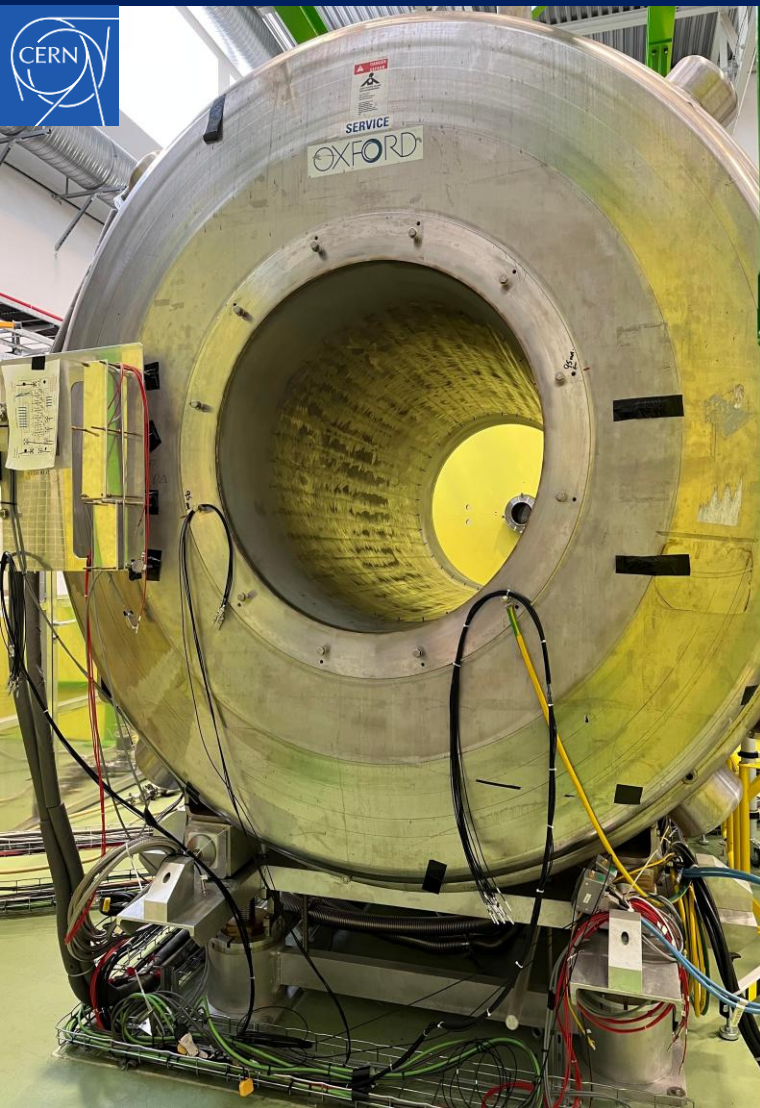

(d,pF) in inverse kinematics:

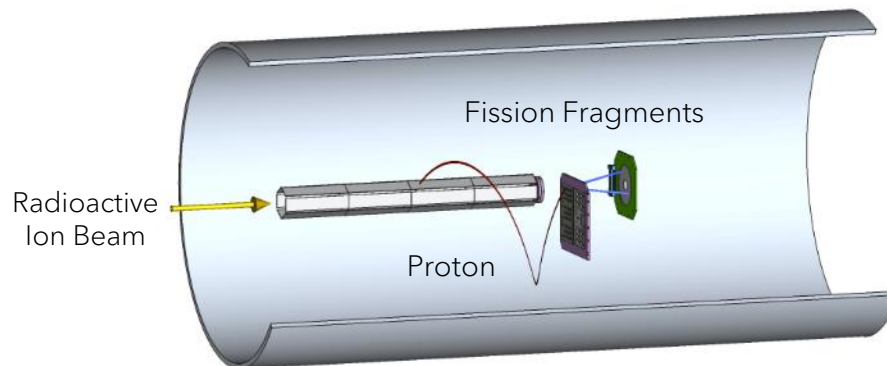

- Uniform magnetic field (2T).
- Target and detectors inside the solenoid.
- Charged particles follow helical trajectories.
- Particles detected along the magnet axis.

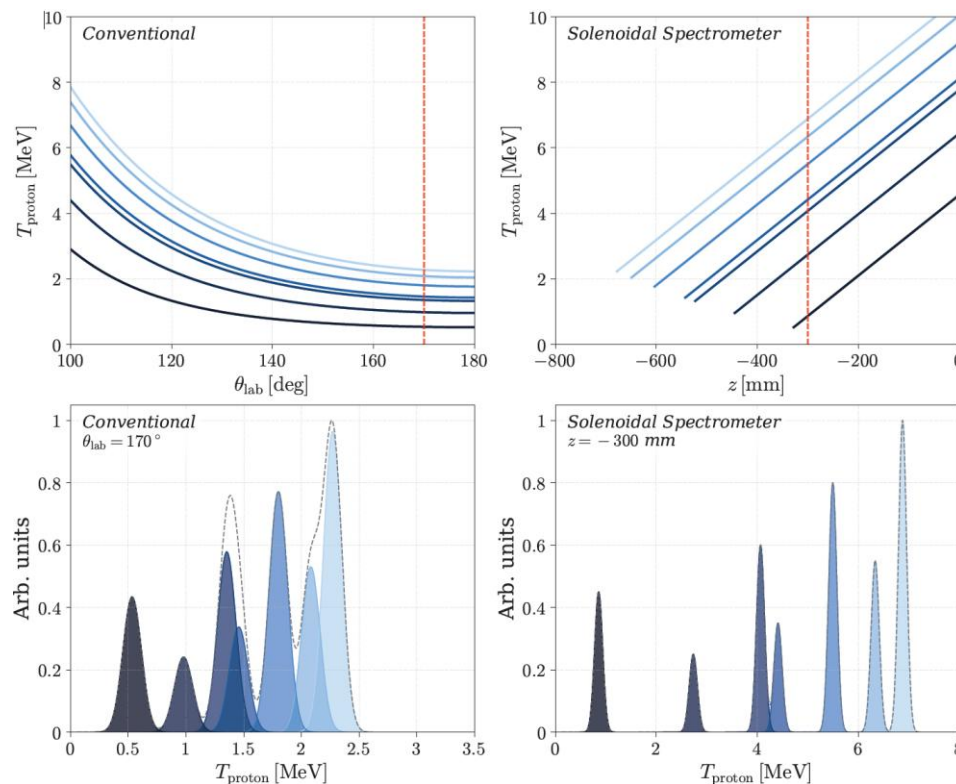

$$E_{cm} = E_{lab} + \frac{mV_{cm}^2}{2} - \frac{mzV_{cm}}{T_{cyc}}$$

- **Considerably better** energy resolution of the populated state in the compound nucleus.
- Solution for kinematics compression.
- Background reduction in having the proton detector placed upstream.

ISOLDE Solenoidal Spectrometer



The background is a deep, dark blue with a subtle, glowing fractal-like pattern in the center. The pattern consists of intricate, branching structures that resemble a stylized flower or a complex geometric design, rendered in lighter shades of blue and white. The overall effect is ethereal and futuristic.

Experimental Setup

A novel setup for studying (d,pF) reactions at ISS

(d,pF) in inverse kinematics:

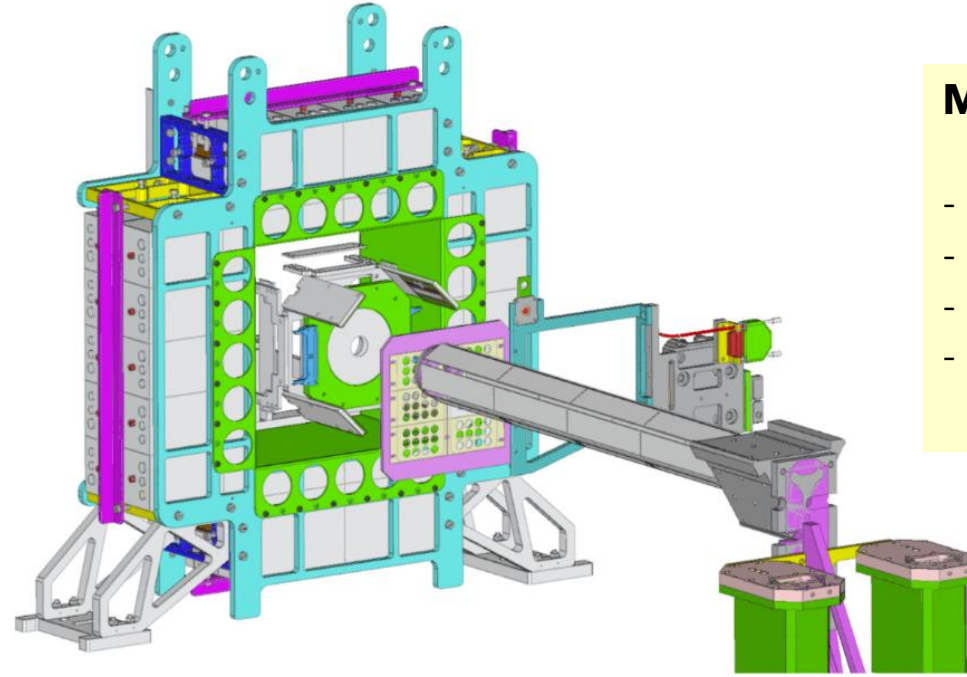
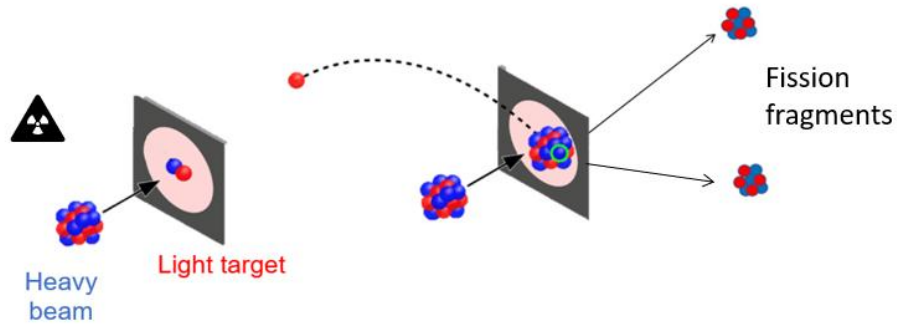

Measured:

- Protons
- Scattered deuterons
- Fission fragments (FFs)
- γ -rays from FFs.



Protons: array of position-sensitive silicon detectors.

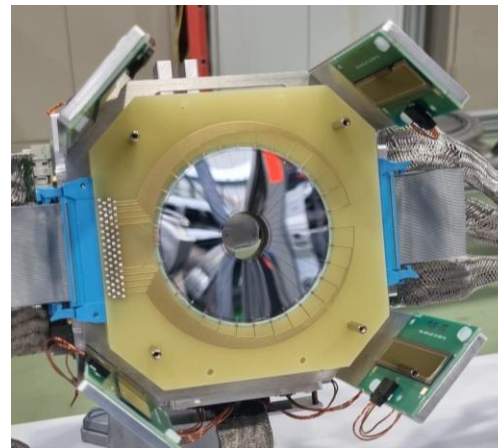

Fission Fragments: $\Delta E - E$ Double Sided Silicon Detectors.

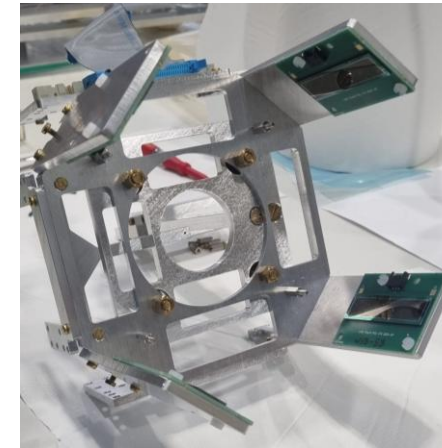

Deuterons: Luminosity monitor with 4 position-sensitive silicon detectors.

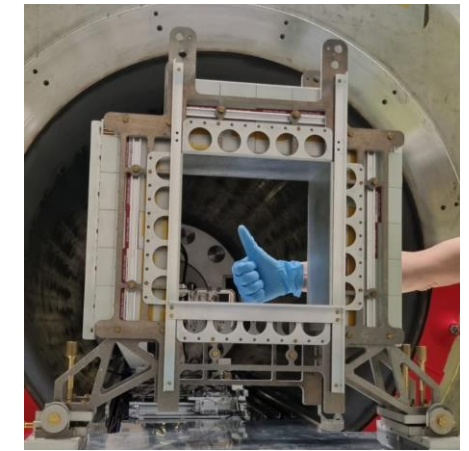

γ -rays: 28 CeBr₃.

Commissioning with stable beam

$^{22}\text{Ne}(d,p)^{23}\text{Ne}$ 6 MeV/u

ISOLDE, CERN

June 3 -10, 2025

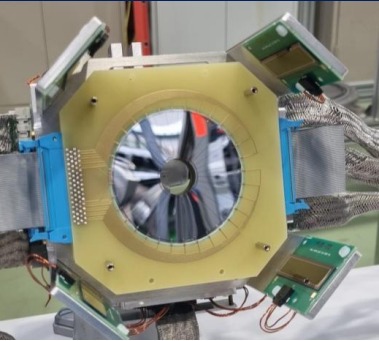

Fission detectors

CD₂ target

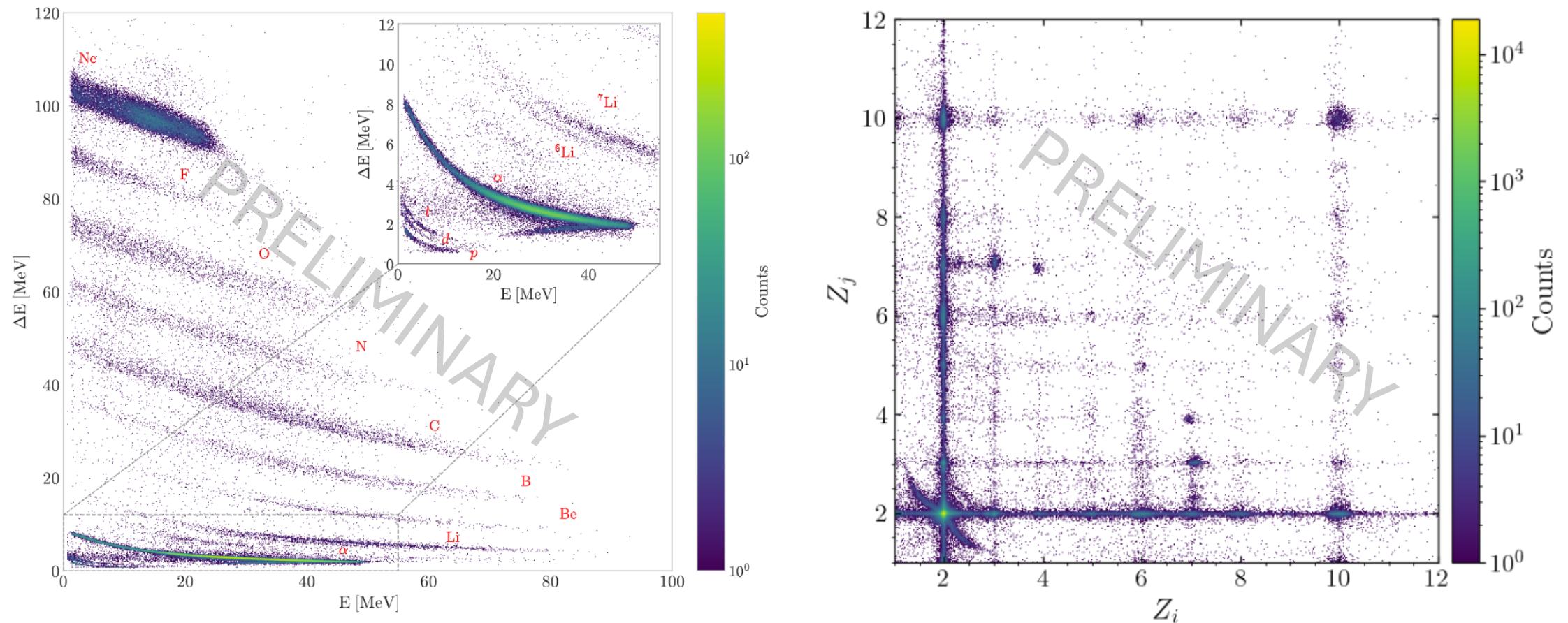

Commissioning with stable beam: $^{22}\text{Ne}(d,p)^{23}\text{Ne}$

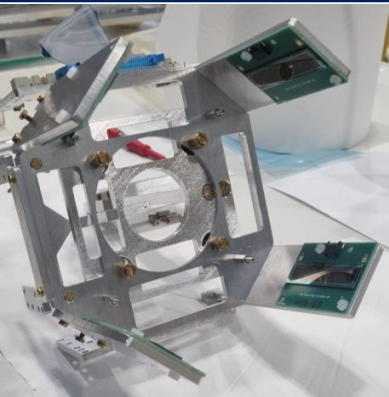

Luminosity Monitor

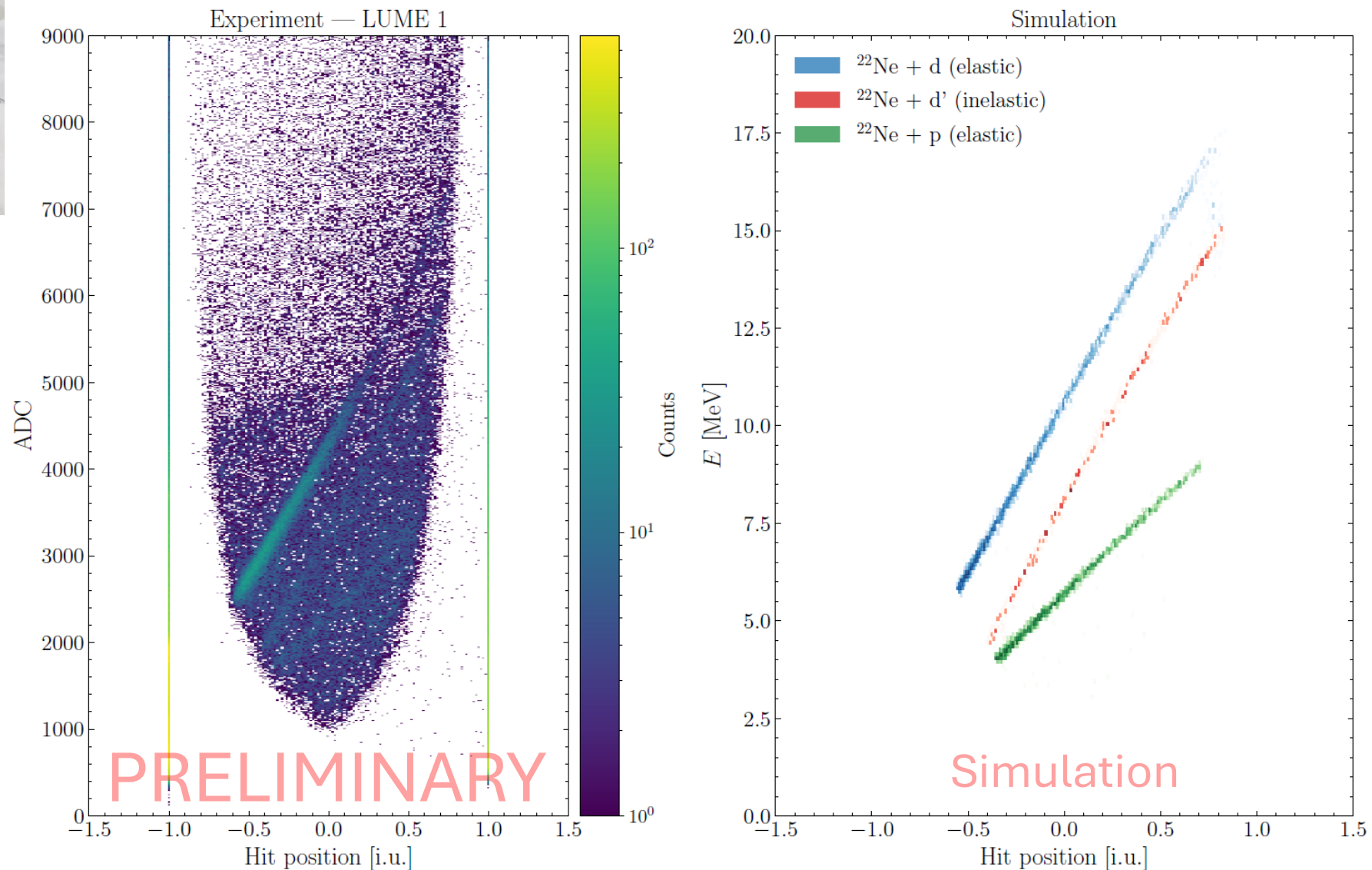

Commissioning with stable beam: $^{22}\text{Ne}(d,p)^{23}\text{Ne}$

$$E_X = -m_2 + \sqrt{M_C^2 + m_1^2 - 2\gamma M_C(E - \alpha\beta z_{hit})}$$

Si-array

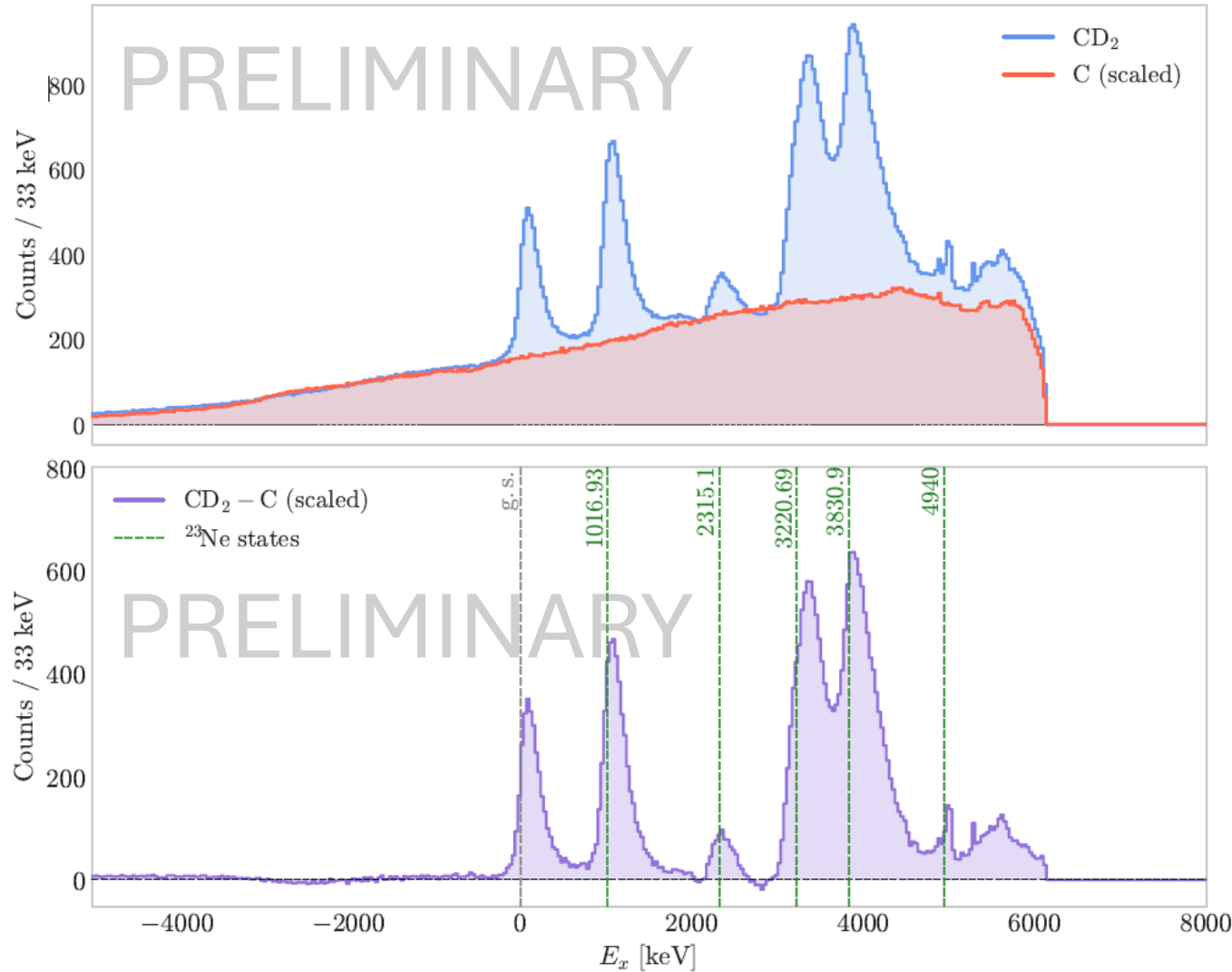
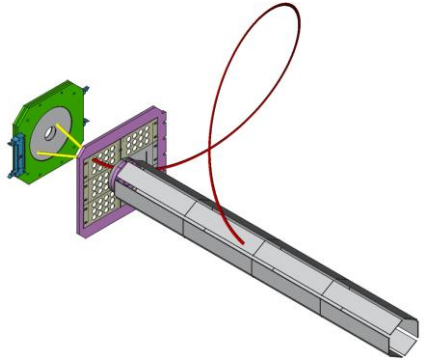

Commissioning with stable beam: $^{22}\text{Ne}(d,p)^{23}\text{Ne}$

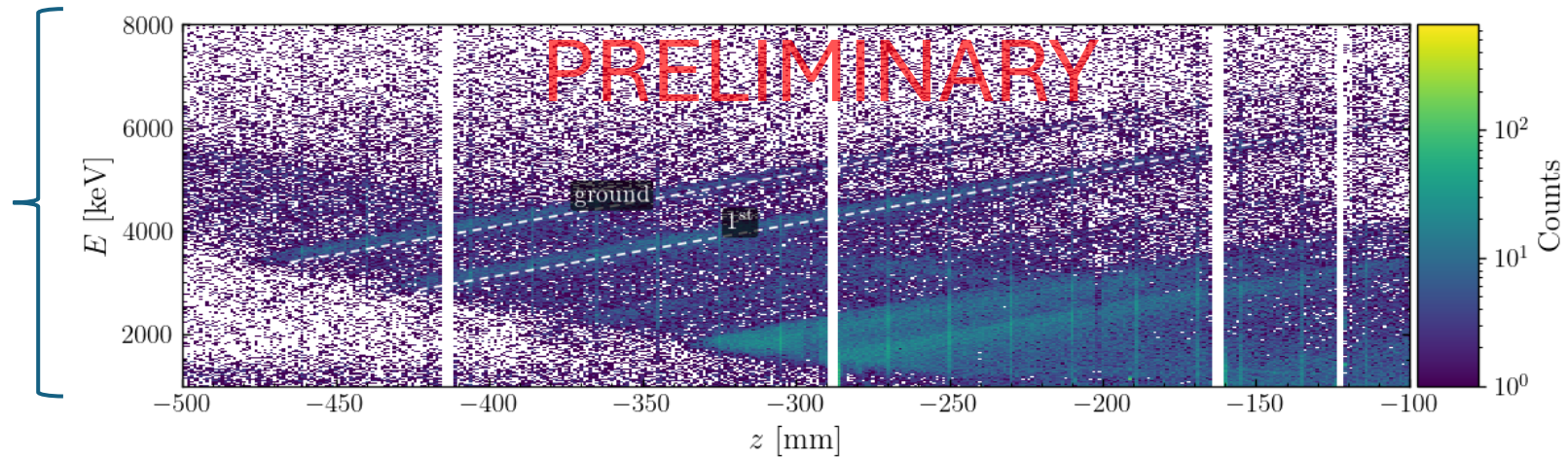
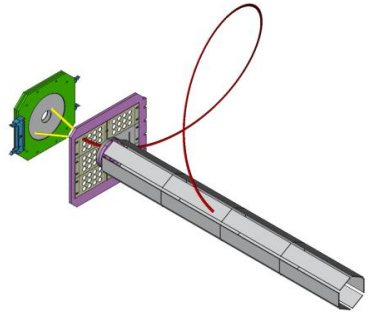

CeBr₃
crystals

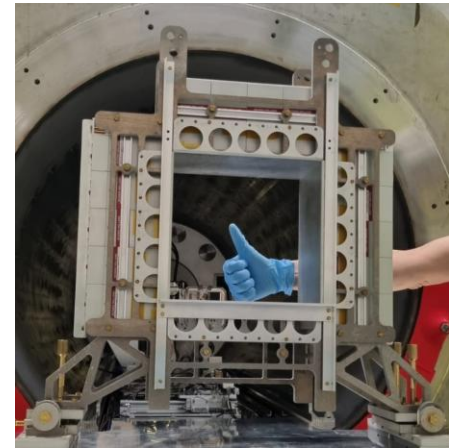
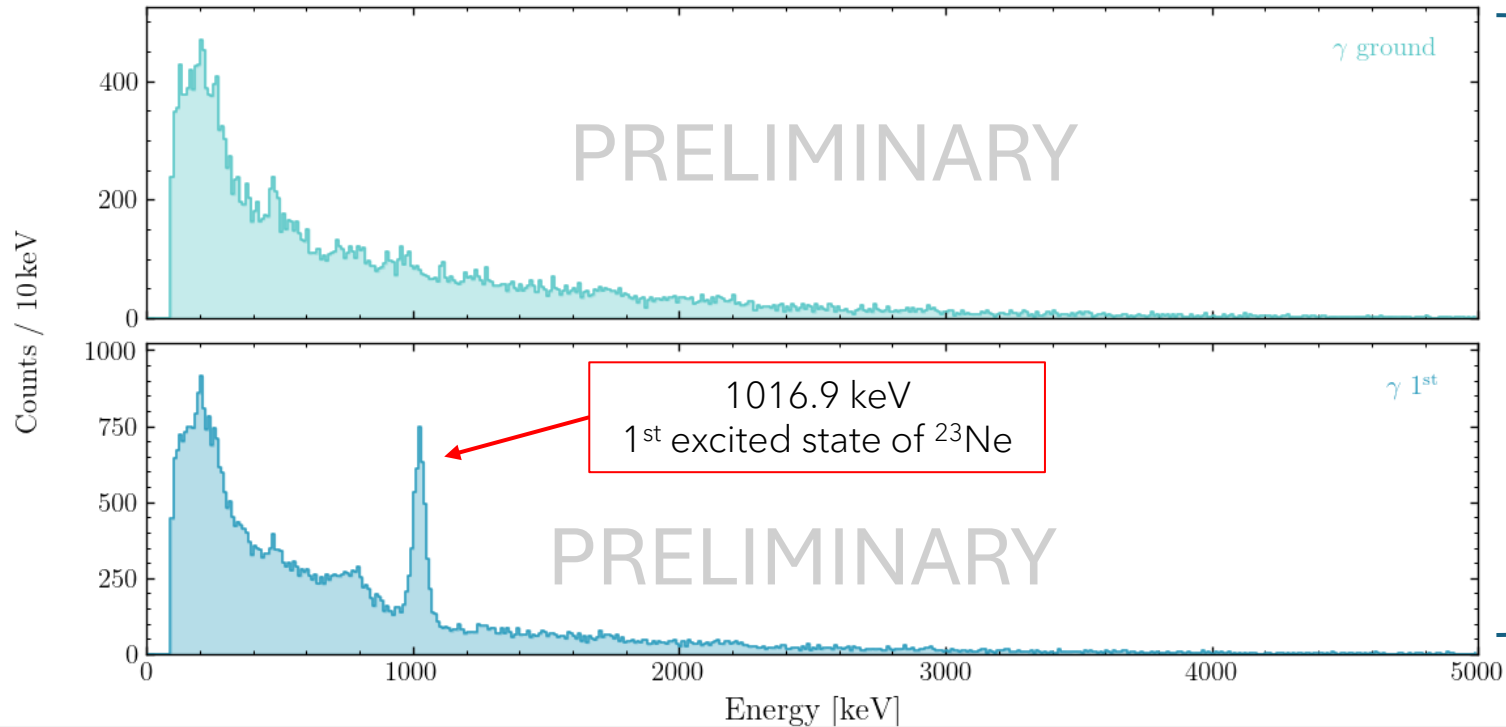

A visualization of particle tracks, likely from a heavy-ion collision, showing a central region with a dense concentration of tracks and several distinct lobes extending outwards. The tracks are rendered in a light blue/cyan color against a dark blue background.

Experiment IS739

ISOLDE, CERN
July 10 - 20, 2025

IS739: Fission of ^{230}Ac

- **Practical choice** for investigation: based on the fission barrier estimated by GEF, it lies within the capabilities of the facility (available intensity and energy of the beam).
- **No conclusive data** on fission at low excitation energies.
- The **first study** of fission using **radioactive** beams in inverse kinematics with a solenoidal spectrometer.

^{230}Ac	
Sn [1]	4.923 MeV
Fission barrier height [2]	7.01 MeV
P_f (1st chance) [2]	3%

[1] M. Wang et al. Chinese Physics C 45, 030003 (2021).

[2] K.-H. Schmidt et al. Nucl. Data Sheets 131, 107 (2016).

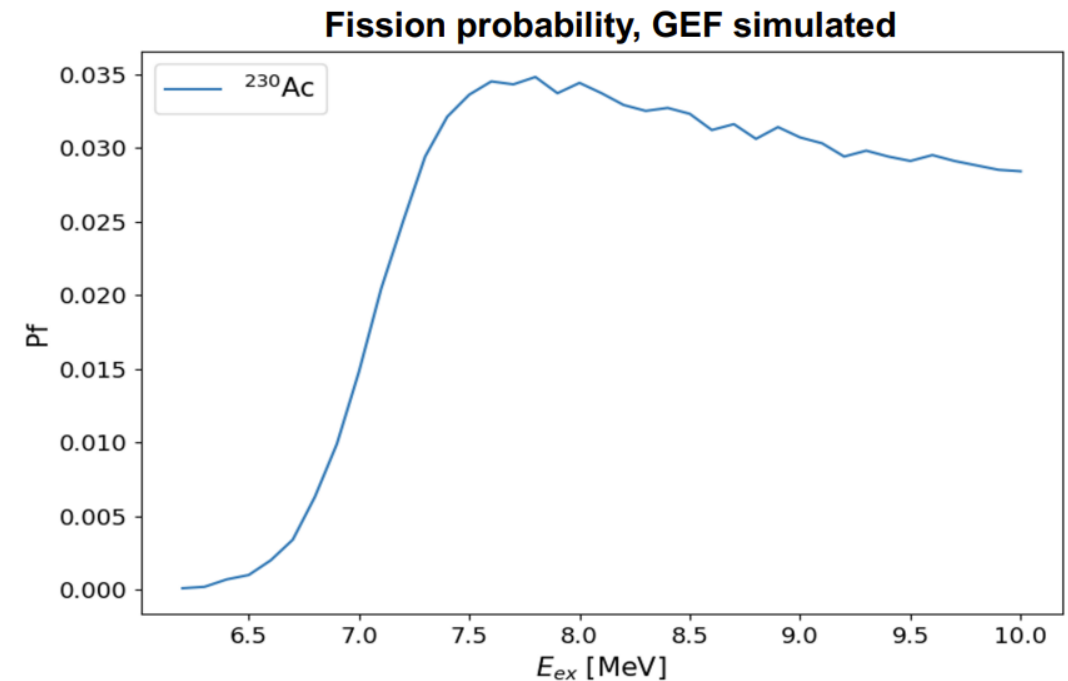

✓ Approved INTC proposal.

✓ Beam time and setup geometry optimized to measure fission of ^{230}Ac .

A good candidate: ^{230}Ac

Technical challenges during the experiment:

- Limited beam energy ($< 8 \text{ MeV/u}$) (will be better after LS3).
- Production of ^{229}Ac beam in difluoride form not possible.
 - Saturation of HIE-ISOLDE trap likely due to contaminants.
- Monofluoride beam: production yield too low.
- Change from ThC_x to UC_x primary target required.
- Too low statistics.



[1] M. Wang
[2] K.-H, Sch

A good candidate: ^{230}Ac

- Practical choice estimated by (available inte
- No conclusive
- The first study kinematics wit

Technical challenges during the experiment:

- Limited beam energy ($< 8 \text{ MeV/u}$) (will be better after LS3).
- Production of ^{229}Ac beam in difluoride form not possible.
 - Saturation of HIE-ISOLDE trap likely due to contaminants.
- Monofluoride beam: production yield too low.
- Change from ThC_x to UC_x primary target required.
- Too low statistics.



Change of isotope during the experiment



[1] M. Wang
[2] K.-H, Sch

IS739: $^{232}\text{U}(d,pF)$ at 7.34 MeV/u

Luminosity monitors

CD₂ target

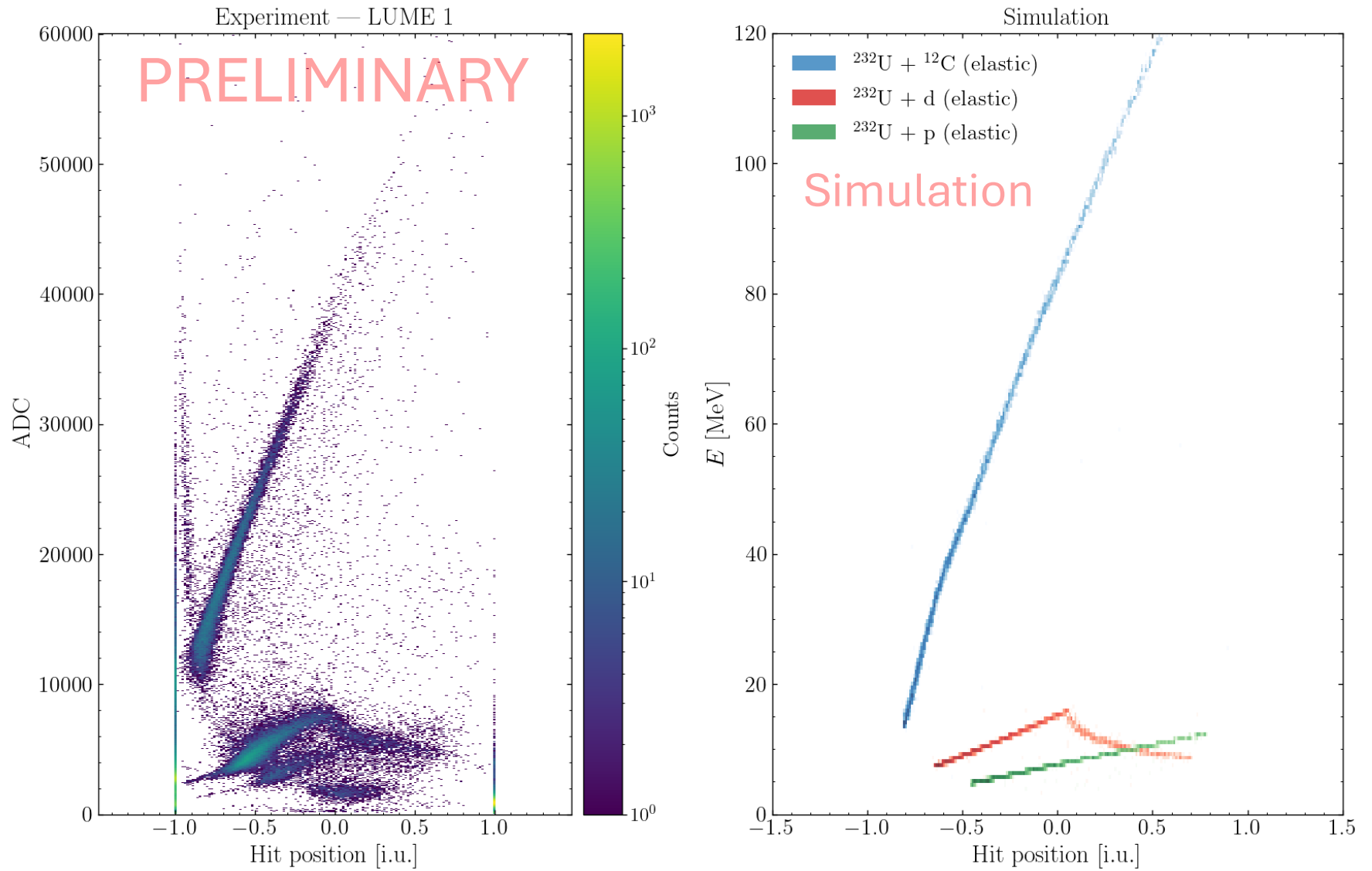

Fission detectors

CD₂ target

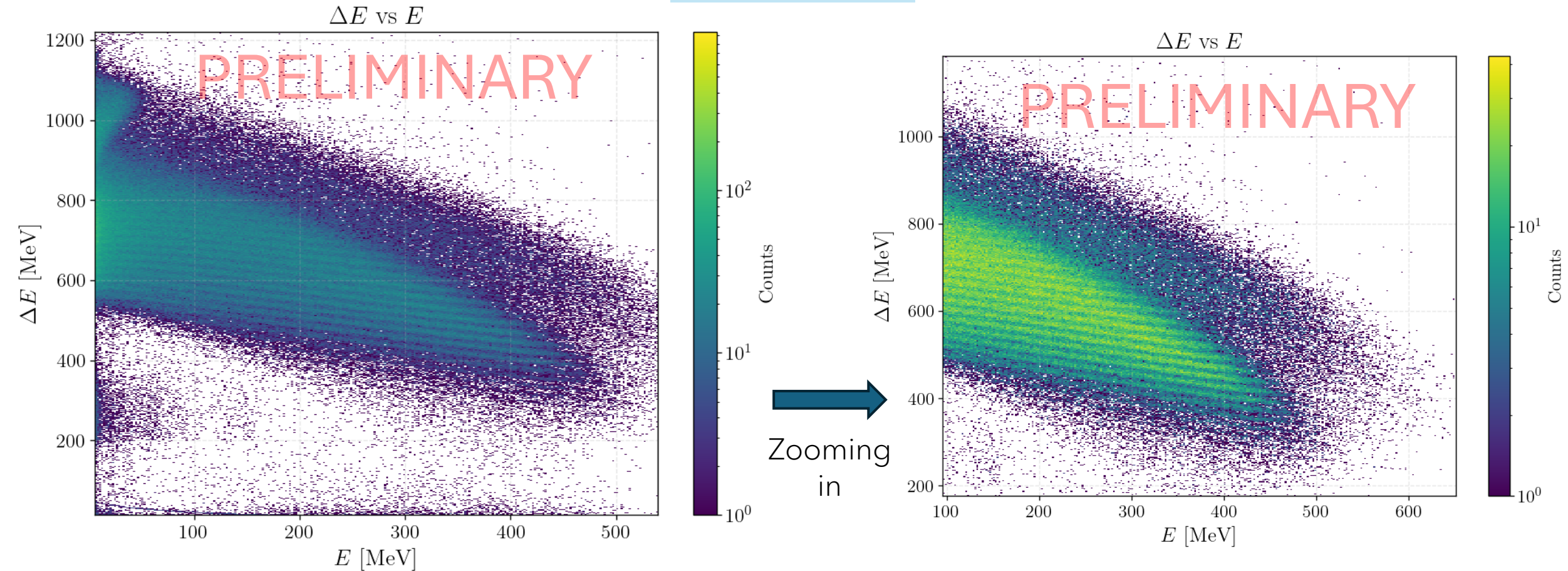

Fission detectors

CD₂ target

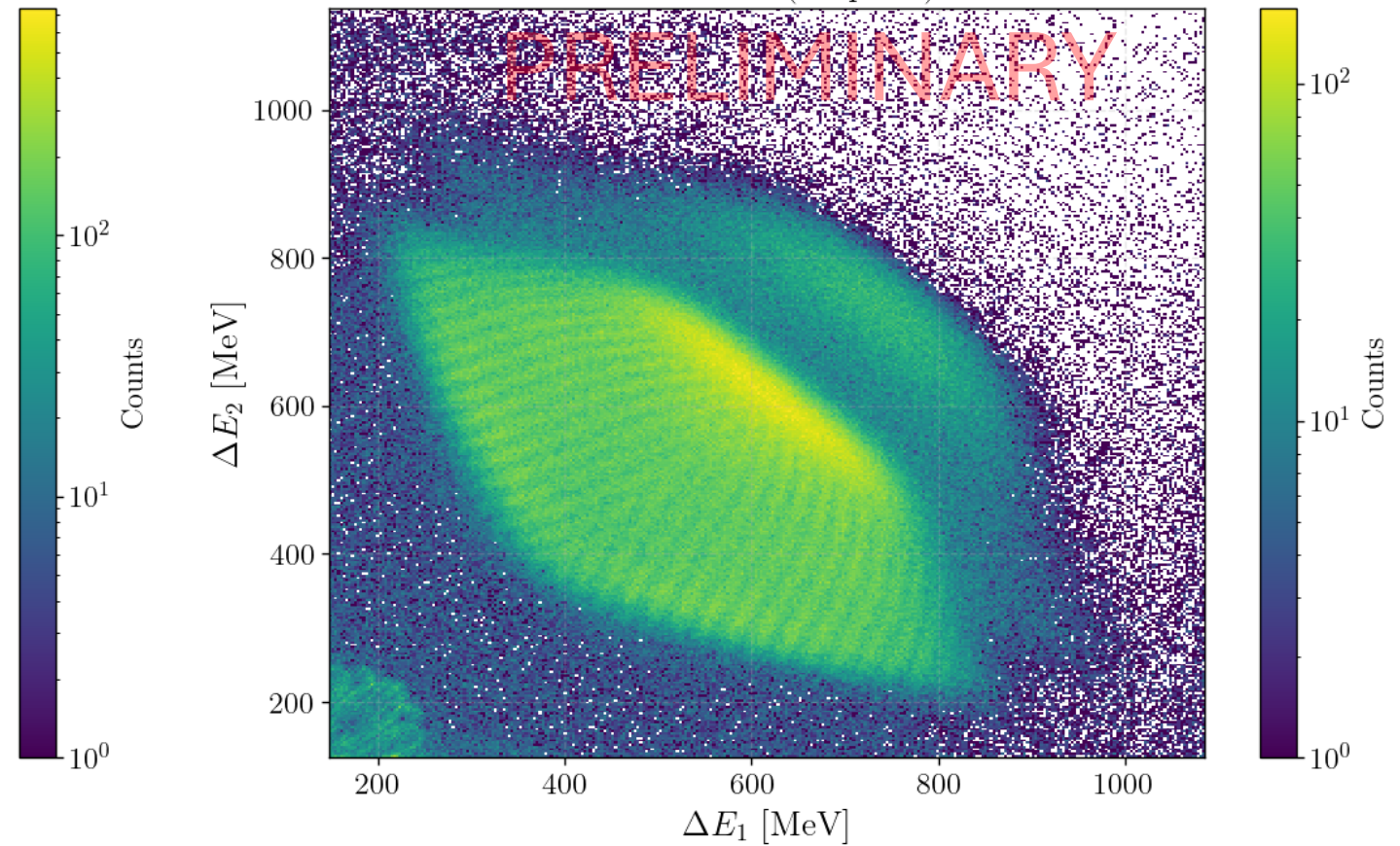
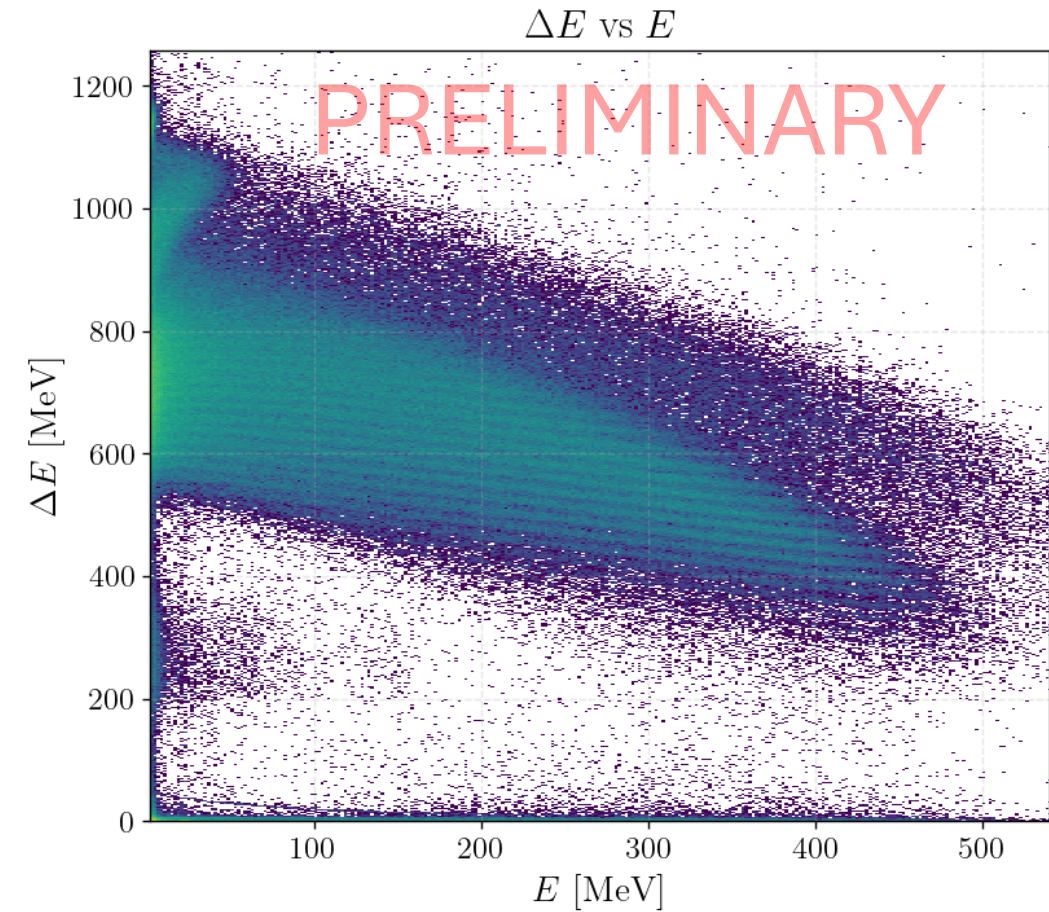

Fission detectors

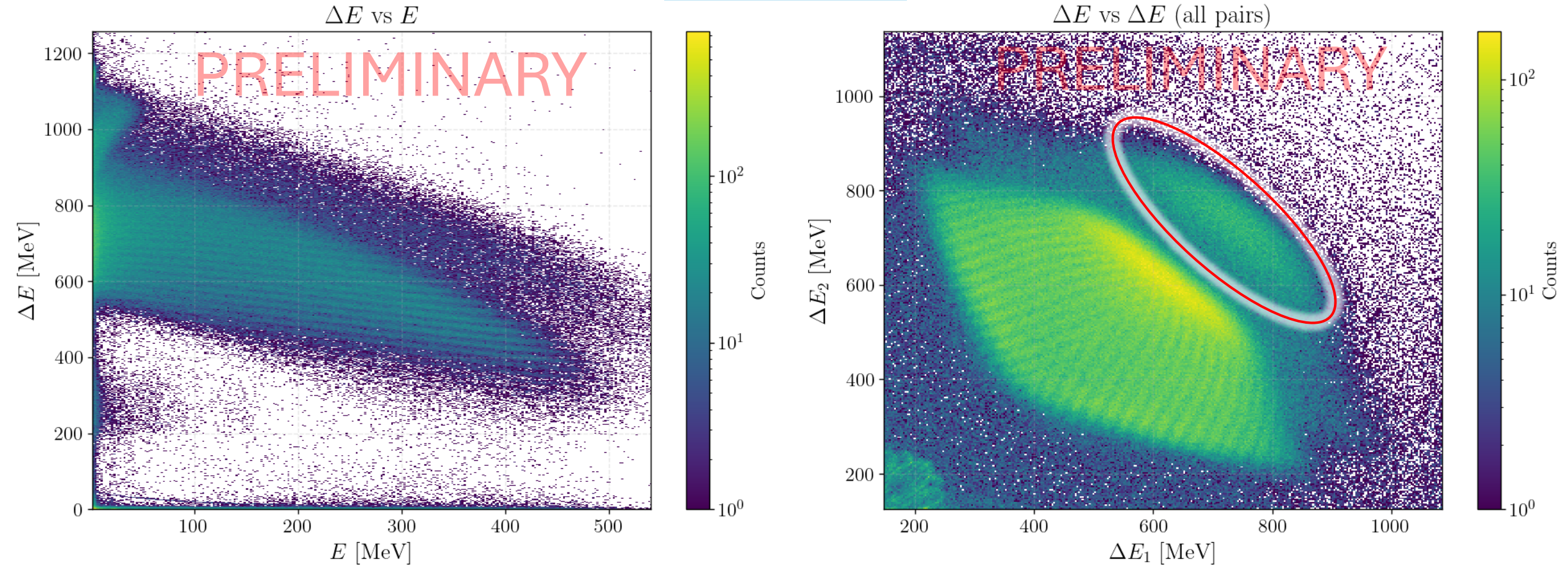
CD₂ target

The Puzzle

- Extracting the P_f becomes more difficult as expected if a fissile contaminant is present in the beam!

Gate on:
1 proton in coincidence with 1 FF

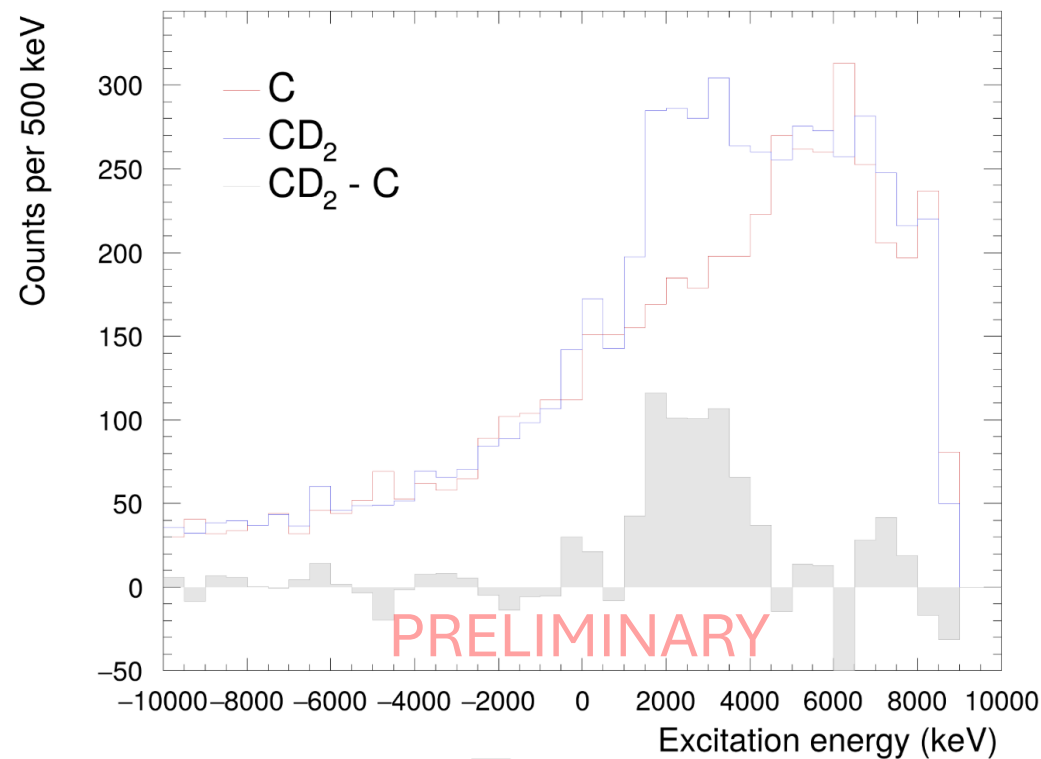

The Puzzle

- Extracting the P_f becomes more difficult as expected if a fissile contaminant is present in the beam!

Gate on:
1 proton in coincidence with 1 FF

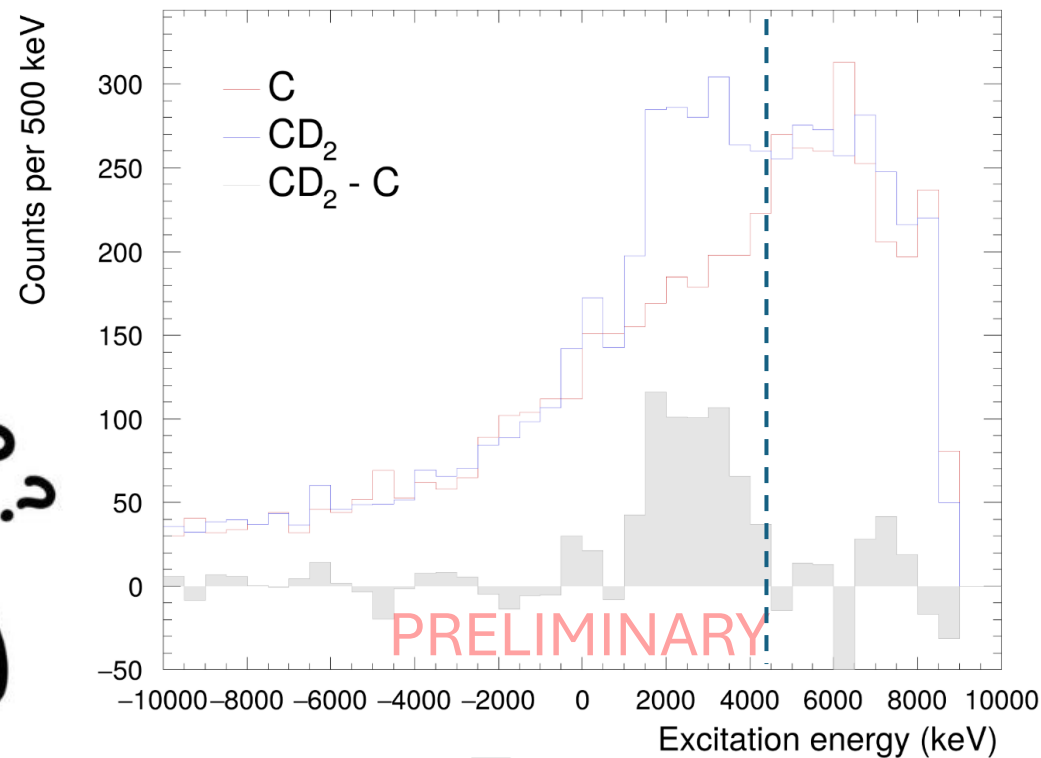

GEF prediction

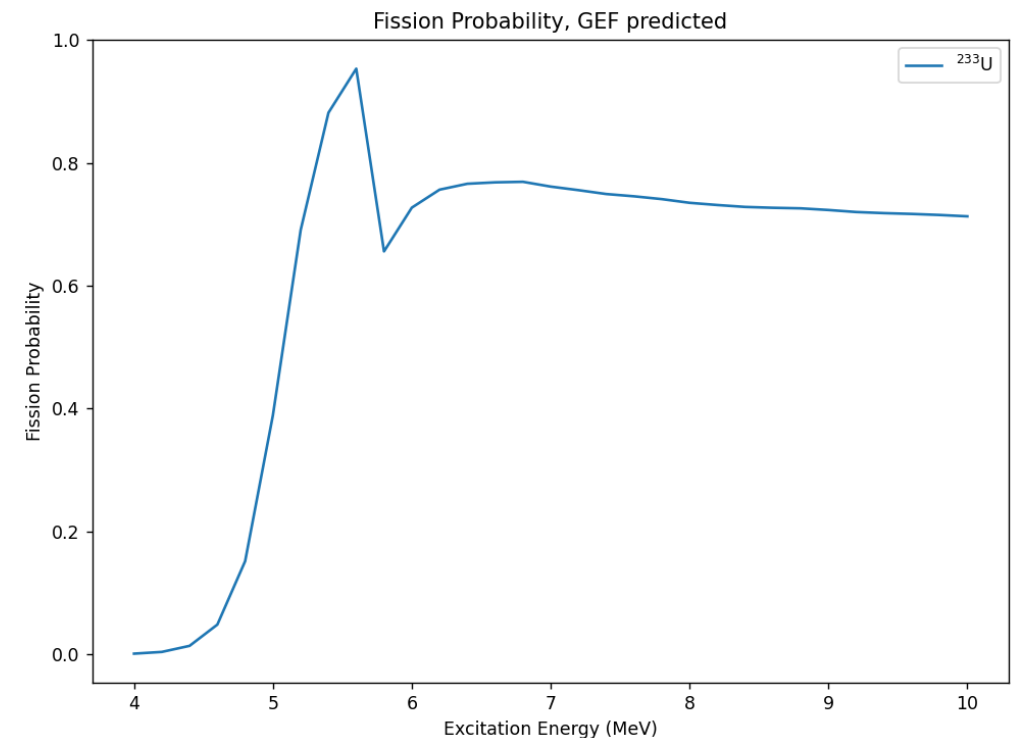

The method works

- Detectors performed well!
- First (d,p) measurement on ^{232}U .
- Calibration done ✓

Analysis in progress:

- Calculation of efficiencies and comparison with simulations.
- Extraction of P_f (after beam contaminant background subtraction)
- Attempt for FFs PID.
- γ -ray analysis → for questions please talk to Henna Joukainen!

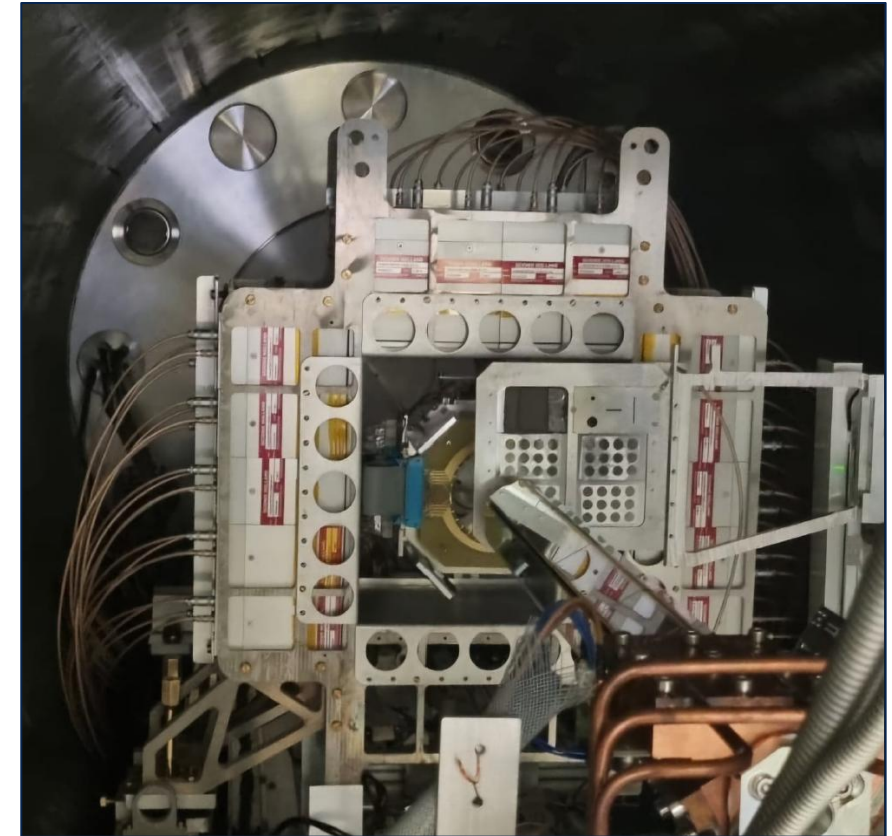

Thank you for your attention!

Collaboration

A. Kawęcka, H. T. Törnqvist, A. Heinz, H. T. Johansson, T. Nilsson, B. Jonson, E. A. M. Jensen, H. Joukainen, B. Johansson, A. Svärdström, S. Persson, P. MacGregor, F. Rowntree, G. Willmott, D. K. Sharp, A. G. Smith, T. Wright, M. Włodarczyk, N. Sosnin, M. Au, F. Browne, P. A. Butler, A. Camaiani, A. Ceulemans, D. J. Clarke, A. J. Dolan, S. J. Freeman, L. P. Gaffney, S. A. Giuliani, B. R. Jones, B. P. Kay, J. Klimo, M. Labiche, I. Lazarus, J. Ojala, B. Olaizola, R. D. Page, G. Martínez-Pinedo, O. Poleshchuk, R. Raabe, S. Reeve, A. Rodriguez, S. Rothe, T. Beck, H. Agarwal, A-C. Larsen, V. W. Ingeberg, J. Henderson, Y. Kucuk, I. Boztosun, H. Dapo, H. Sansar, J.S. Nielsen.



CHALMERS

*Knut and Alice
Wallenberg
Foundation*



Swedish
Research
Council



ISOLDE Solenoidal
Spectrometer

