

# THE BETA-DECAY OF $^8\text{He}$

Jeppe Schultz Nielsen

Department of Physics and Astronomy, Aarhus University

15<sup>th</sup> Nordic Meeting on Nuclear Physics

6 May 2026

# MOTIVATION

- Antineutrino detectors

- ▶ Inverse  $\beta$ -decay reaction:

$$\bar{\nu}_e + p \rightarrow e^+ + n$$

- ▶  $\beta$ -delayed neutron emission:

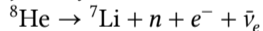

- Few-body interactions

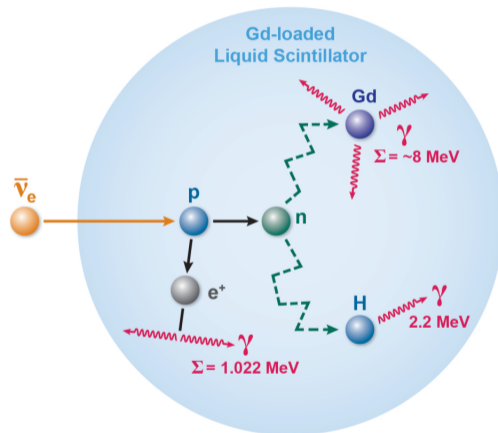

Rep. Prog. Phys. 82, 036201 (2019)

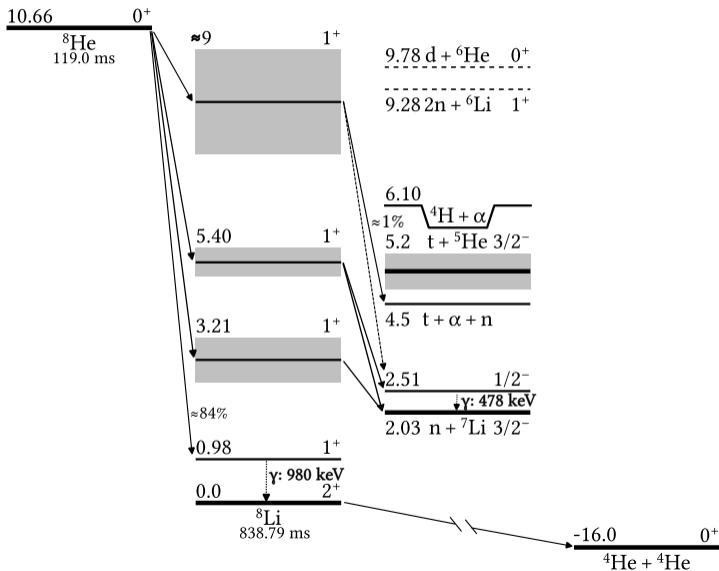
${}^8\text{He}$ 

# SETUP

- 4 DSSDs
  - ▶ Heavy charged particles

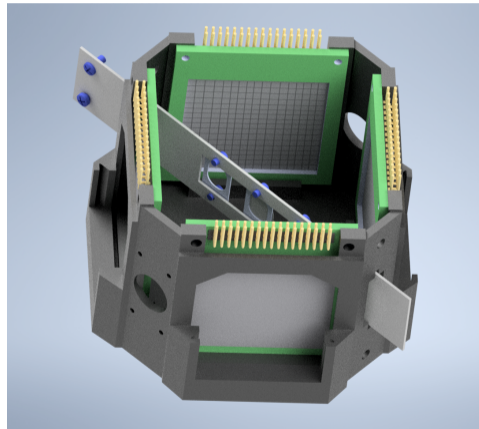

# SETUP

- 4 DSSDs
  - ▶ Heavy charged particles
- 4 plastic scintillators with SiPMs
  - ▶ Betas (neutron TOF start)

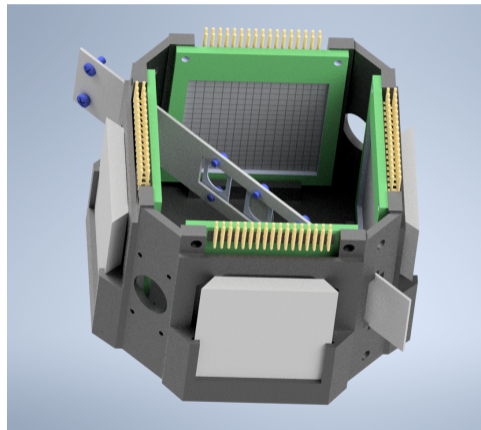

# SETUP

- 4 DSSDs
  - ▶ Heavy charged particles
- 4 plastic scintillators with SiPMs
  - ▶ Betas (neutron TOF start)
- 4 IDS HPGe Clover detectors
  - ▶ Gammas

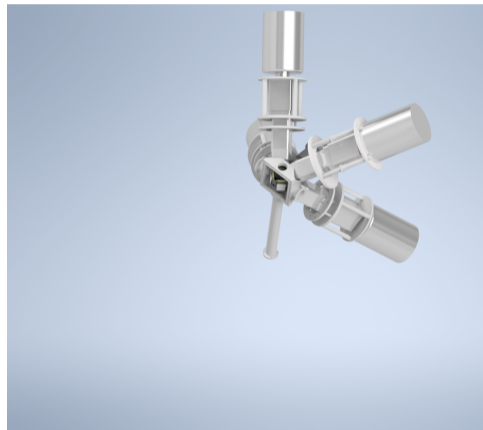

# SETUP

- 4 DSSDs
  - ▶ Heavy charged particles
- 4 plastic scintillators with SiPMs
  - ▶ Betas (neutron TOF start)
- 4 IDS HPGe Clover detectors
  - ▶ Gammas
- 20 INDiE scintillator bars
  - ▶ Neutron TOF stop

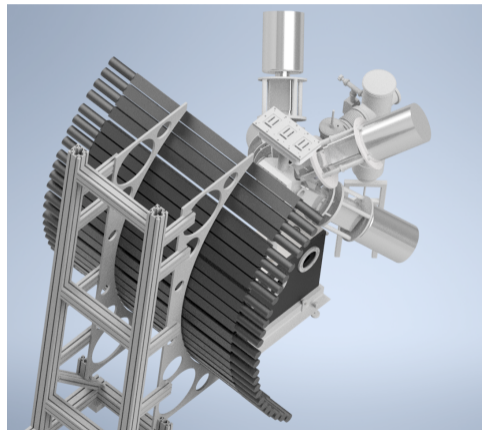

# SETUP

- 4 DSSDs
  - ▶ Heavy charged particles
- 4 plastic scintillators with SiPMs
  - ▶ Betas (neutron TOF start)
- 4 IDS HPGe Clover detectors
  - ▶ Gammas
- 20 INDiE scintillator bars
  - ▶ Neutron TOF stop

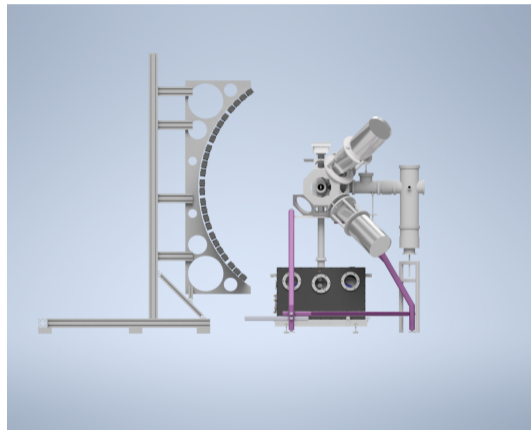

## NEUTRON TOF SPECTRA

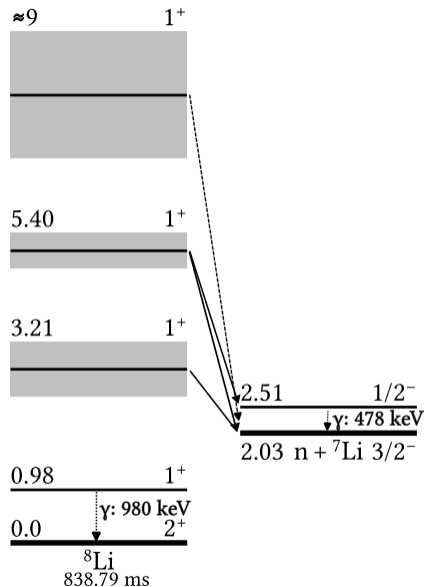
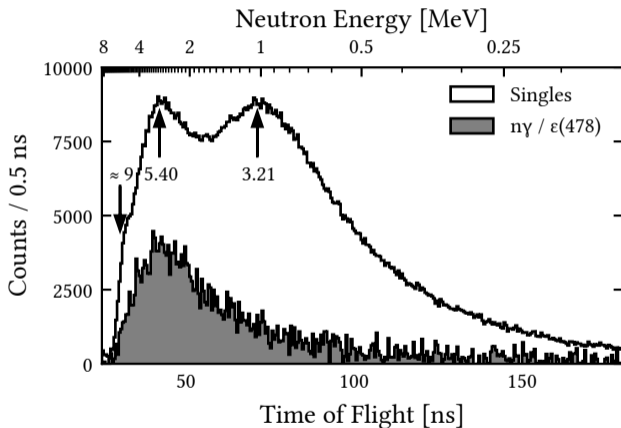

# THREE-BODY BREAKUP PARTICLE IDENTIFICATION

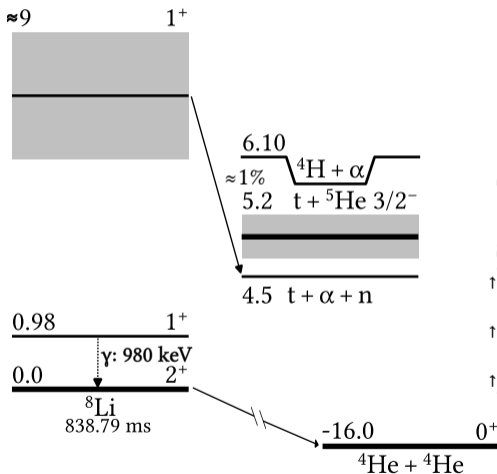

- Particle ID through momentum conservation
- Significant background from  $\alpha + \alpha + x$

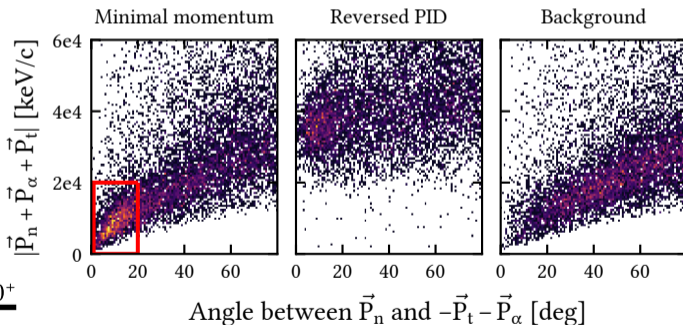

# THREE-BODY BREAKUP

- Decay mechanism?

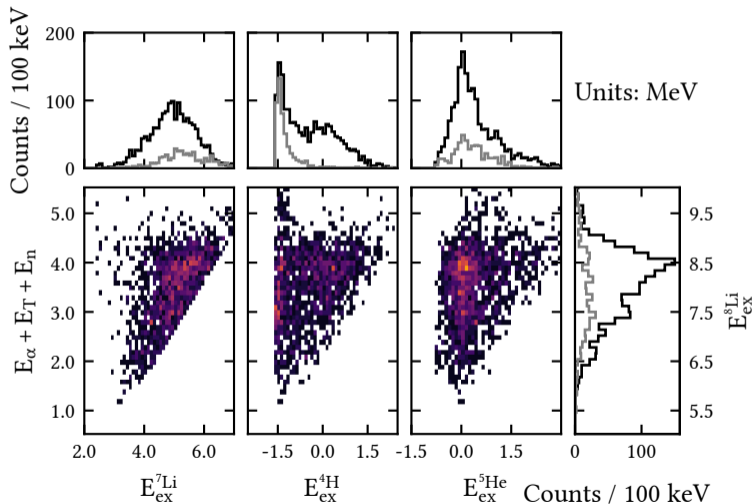

# NEUTRON SCATTERING

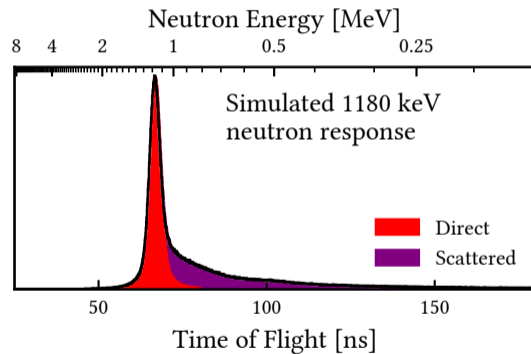
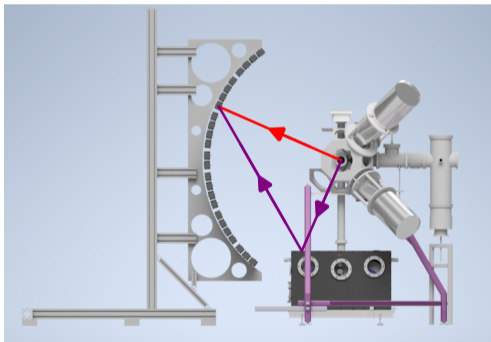

# NEUTRON RESPONSE

- Simulate scattering using GEANT4

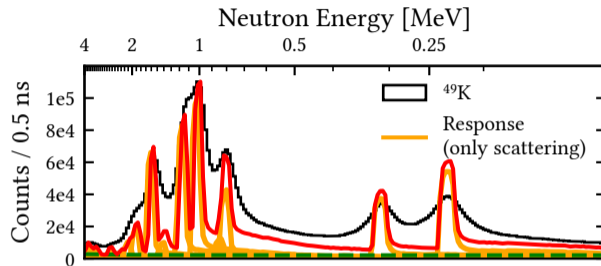

# NEUTRON RESPONSE

- Simulate scattering using GEANT4
- Optimize simulation parameters using  $^{49}\text{K}$  measurement: ADC thresholds, timing resolution...

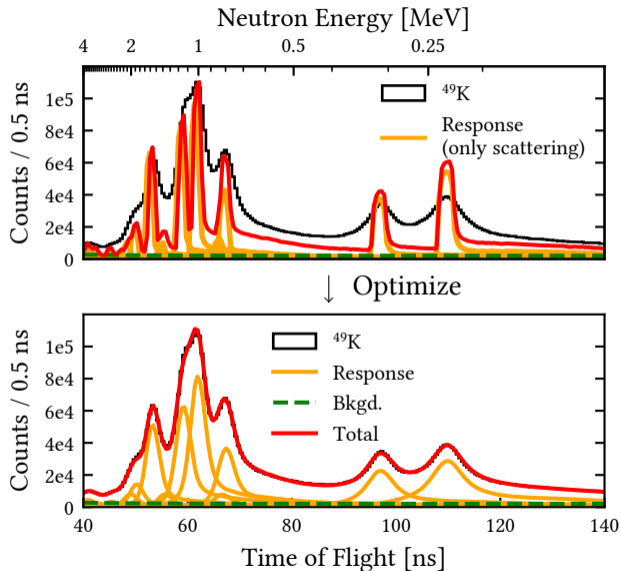

## THREE-BODY BREAKUP RESPONSE

- Kinematics constrained by  $E_{8\text{Li}}$ ,  $E_{5\text{He}}$  and  $\theta_{\text{nt}}$
- Simulate with  $W(\theta_{\text{nt}}) = 1 \pm \frac{3 \cos^2 \theta_{\text{nt}} - 1}{2}$

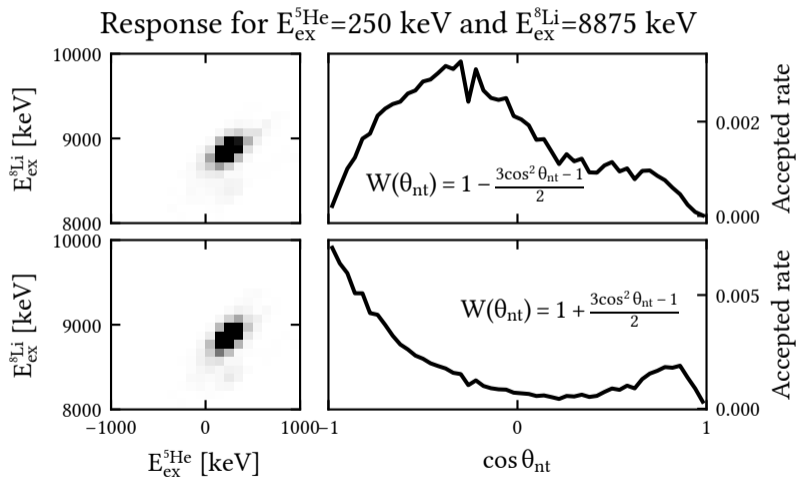

## FOLDING

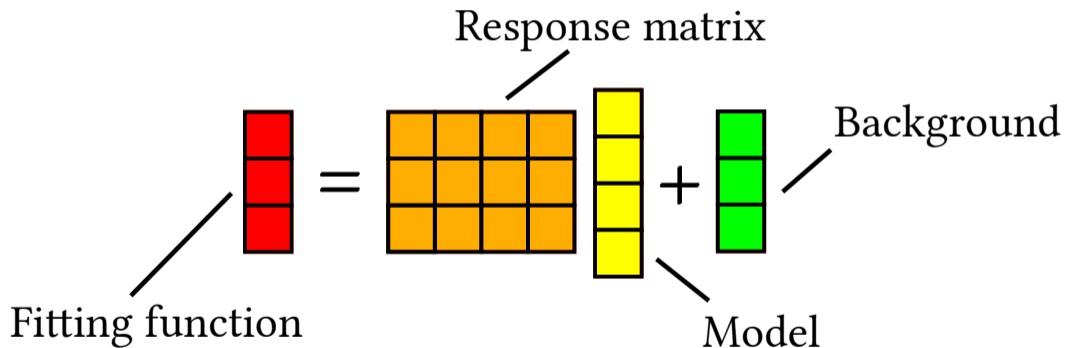

# THREE-BODY R-MATRIX

- R-matrix theory assumes two-particle final states

$$w_c(E) = C^2 f_\beta P_c(E) \left| \sum_{\lambda\mu} g_{\lambda GT} \gamma_{\mu c} A_{\lambda\mu} \right|^2 \quad (1)$$

$$(A^{-1})_{\lambda\mu} = (E_\lambda - E) \delta_{\lambda\mu} - \sum_c [S_c(E) - B_c + iP_c(E)] \gamma_{\lambda c} \gamma_{\mu c} \quad (2)$$

# THREE-BODY R-MATRIX

- R-matrix theory assumes two-particle final states

$$w_c(E) = C^2 f_\beta P_c(E) \left| \sum_{\lambda\mu} g_{\lambda GT} \gamma_{\mu c} A_{\lambda\mu} \right|^2 \quad (1)$$

$$(A^{-1})_{\lambda\mu} = (E_\lambda - E) \delta_{\lambda\mu} - \sum_c [S_c(E) - B_c + iP_c(E)] \gamma_{\lambda c} \gamma_{\mu c} \quad (2)$$

- Model  ${}^5\text{He}$  as a continuous spectrum of long lived states

$$\gamma_{\mu c} \rightarrow \gamma_{\mu c} \rho(E') \quad \sum_c \rightarrow \sum_c \int dE'$$

## R-MATRIX FIT: THREE-BODY

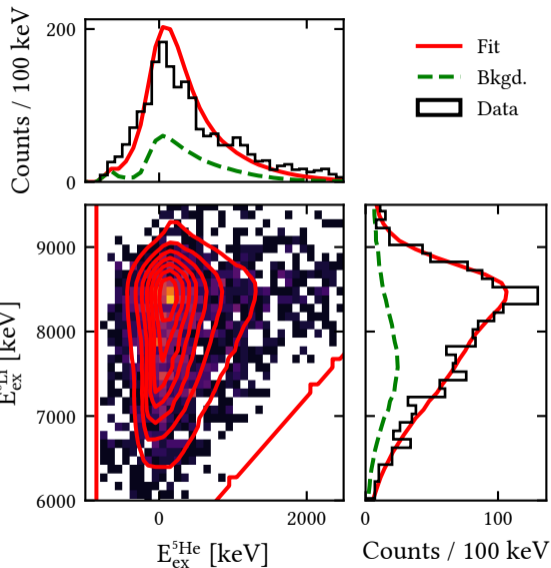
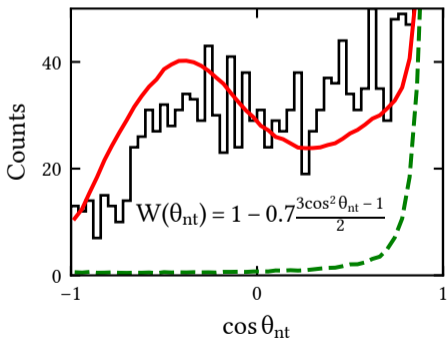

## R-MATRIX FIT: NEUTRONS

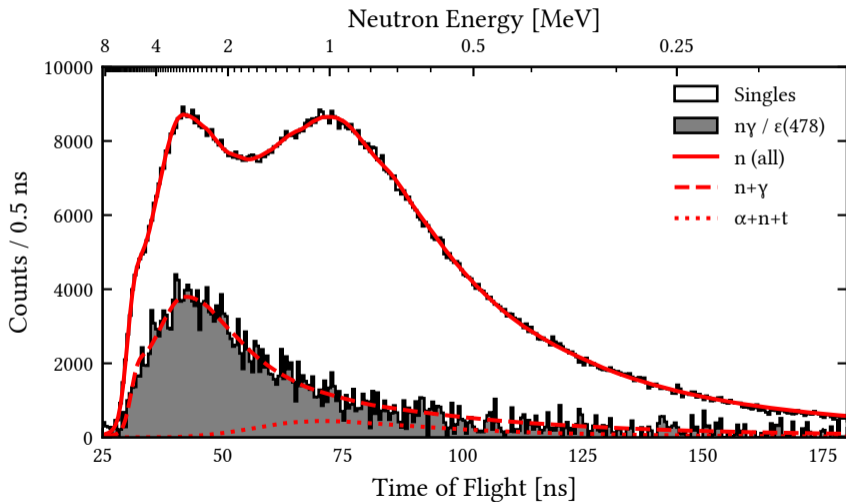

## BETA STRENGTH

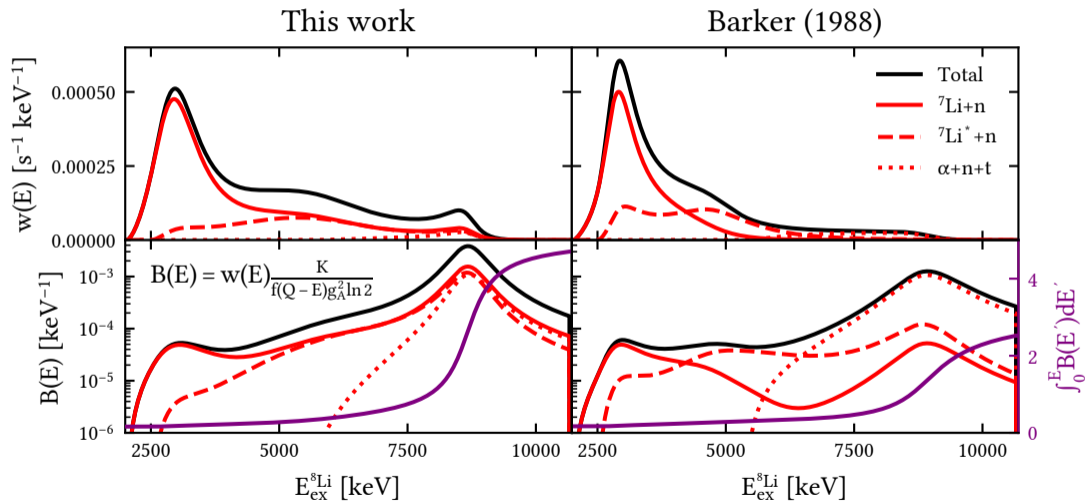

# CONCLUSION

- Experiment sensitive to every branch in  $^8\text{He}$
- Simulate detector response
- R-matrix fit

Jeppe Schultz Nielsen  
Aarhus University, Denmark  
Department of Physics and Astronomy  
jsnielsen@phys.au.dk