

# Toward Practical Quantum Advantage on Early Fault-Tolerant Quantum Computers

Keisuke Fujii

Professor, Graduate School of Informatics, Kyoto University

Professor, Graduate School of Engineering Science, The University of Osaka



京都大学



大阪大学  
OSAKA UNIVERSITY



QIQB



# Fujii Lab: Coherent Transition from Osaka to Kyoto

## Kyoto University

Graduate School of Informatics  
Course of Communications and  
Computer Engineering (CCE)

京都大学  
Kyoto University

Under construction...



4 bachelor students  
PostDoc Haruna

## University of Osaka

Graduate School of Engineering Science/  
Center for Quantum Information and Quantum Biology

Quantum Computing (theory&software) Group at Osaka Univ.

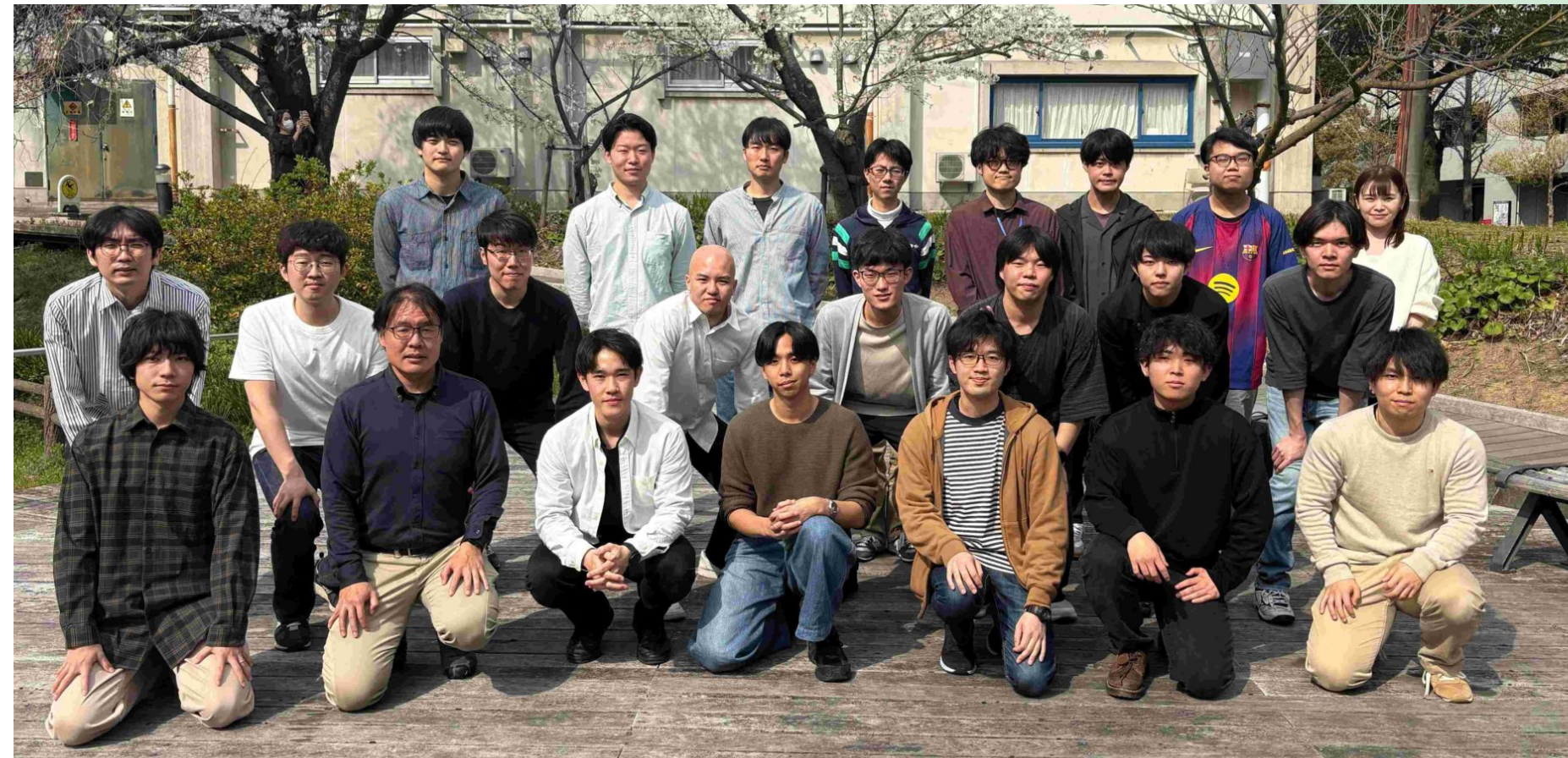

19 students (DC:9, MC:10)  
Assoc. Prof. Hakoshima, Assist. Prof. Okada

**Working on quantum computing from practical viewpoint.**

# Outline

- Introduction: what is computing machine and what is the role of architecture
- Overview of the STAR architecture
- Ver1: space-time efficient analog rotation
- Ver2: error reduction by transversal rotations and postselection
- Ver3: STAR magic mutation

# What is “Computing Machine”?

A computing machine is a physical system that embeds an abstract problem-solving process into physical dynamics.

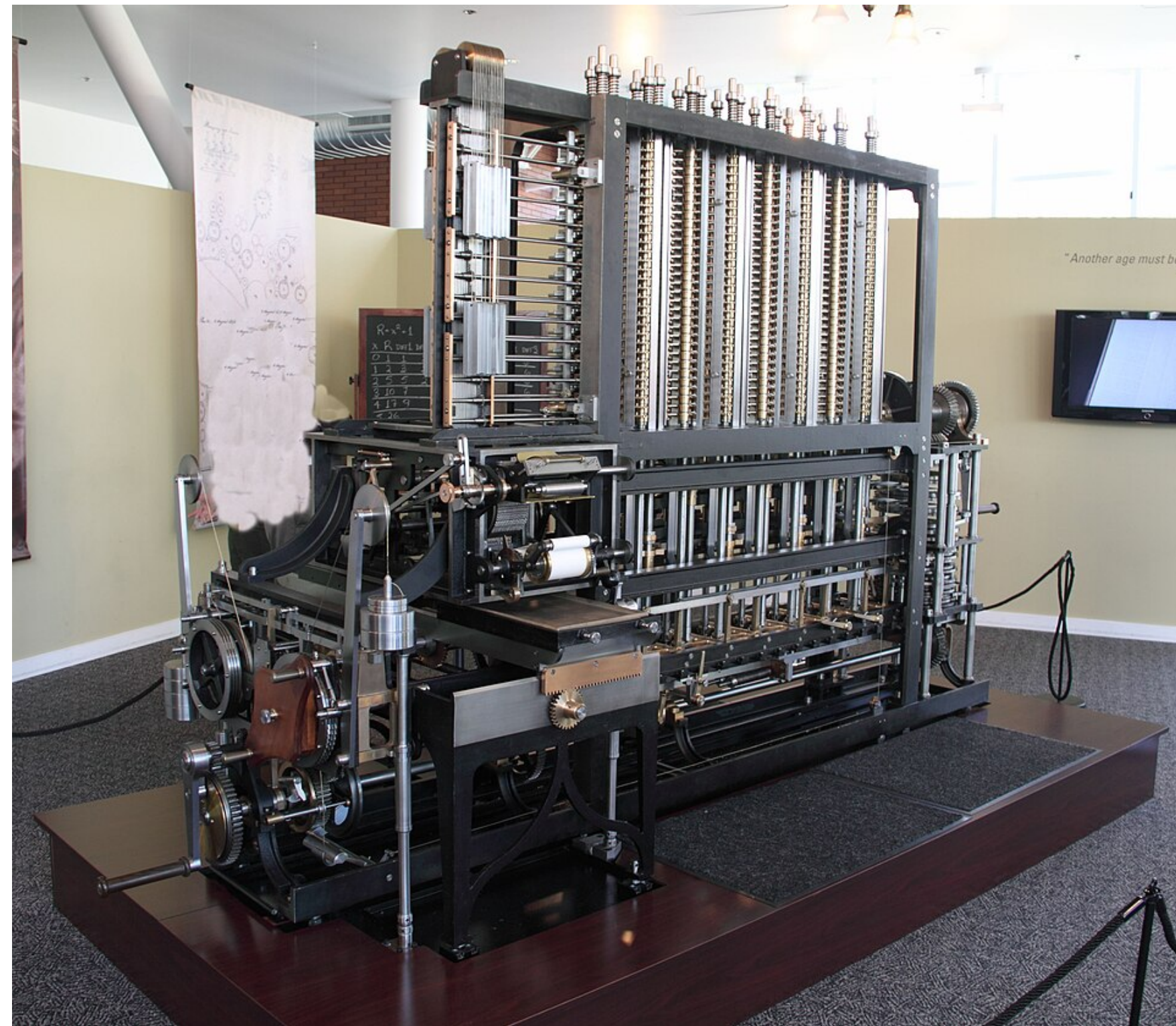

"Difference engine.JPG" by Canticle (Wikimedia Commons), CC BY-SA 3.0

The Difference Engine was a mechanical computing machine designed to automatically calculate mathematical tables using **repeated addition** through **gears and mechanical motion**.

# What is “Computing Machine”?

A computing machine is a physical system that embeds an abstract problem-solving process into physical dynamics.

## Physical Phenomena

electric voltage/current/switch

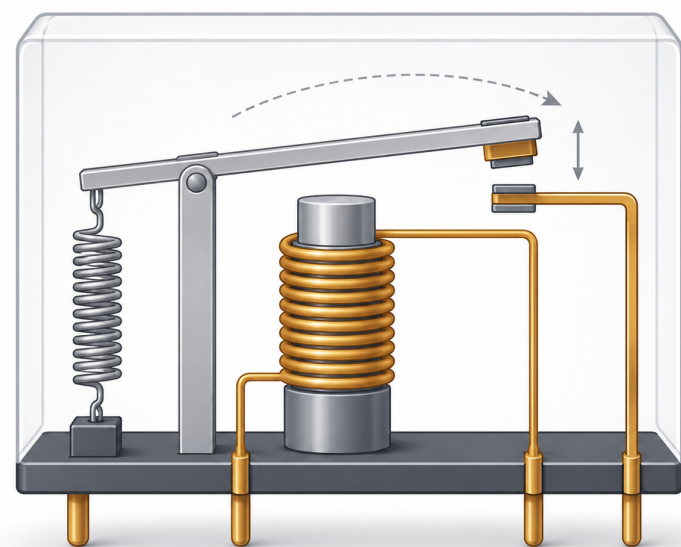
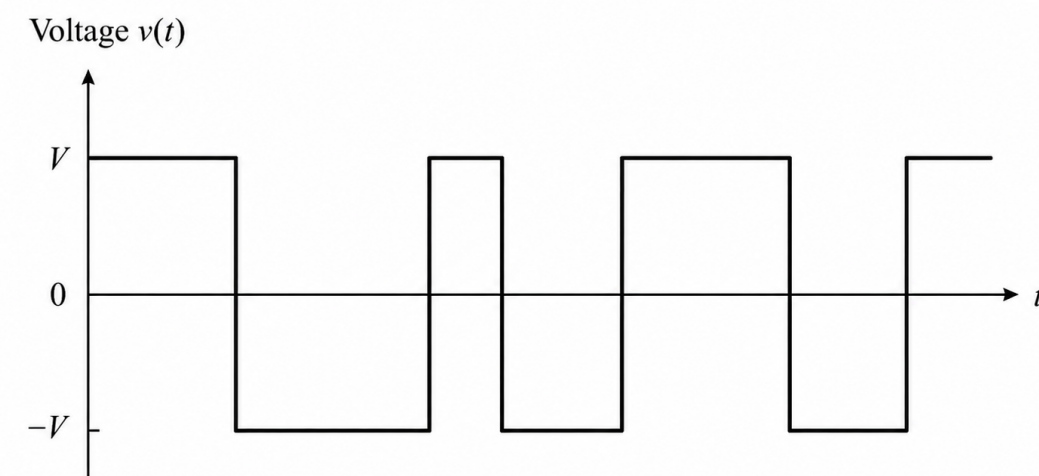

relay

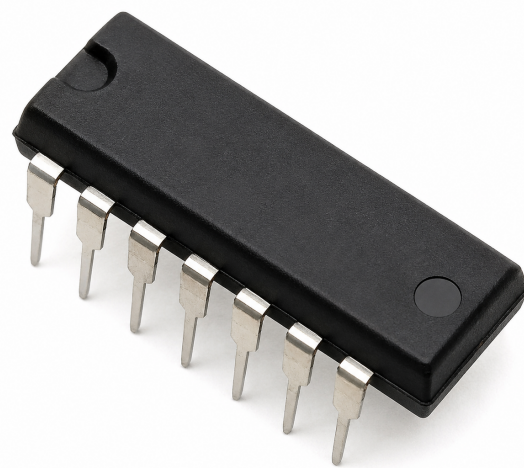

CMOS

## Classical Digital Computation

input:  $x \in \{0,1\}^n$

↓ Boolean function  $f$

output:  $f(x)$

Trigonometric function, and more complicated algorithms...

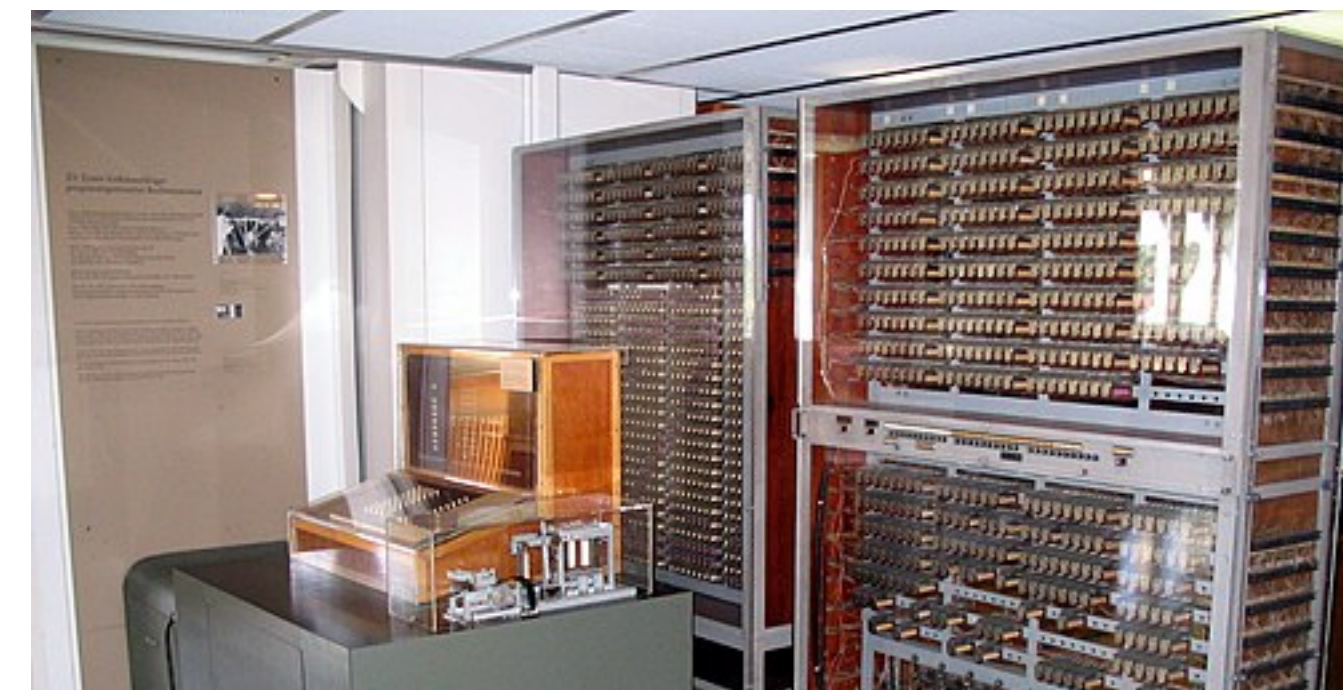

"Z3 Deutsches Museum.JPG" by Venusianer, via Wikimedia Commons, licensed under CC BY-SA 3.0.

# What is “Computing Machine”?

A computing machine is a physical system that embeds an abstract problem-solving process into physical dynamics.

Physical Phenomena

electric voltage/current/switch

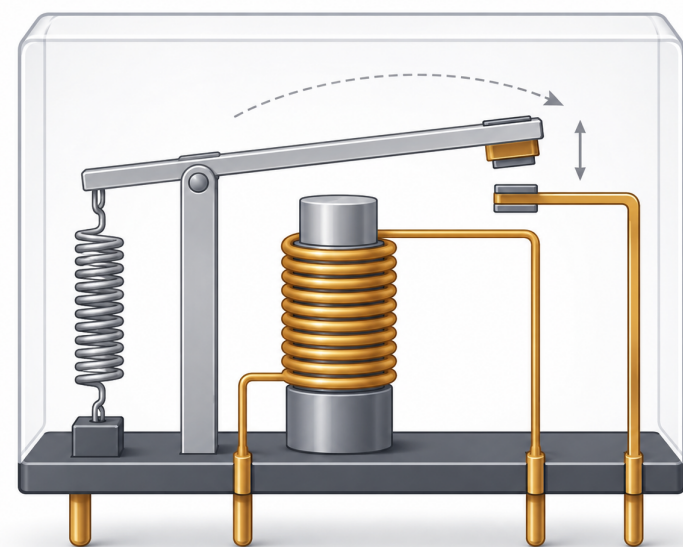
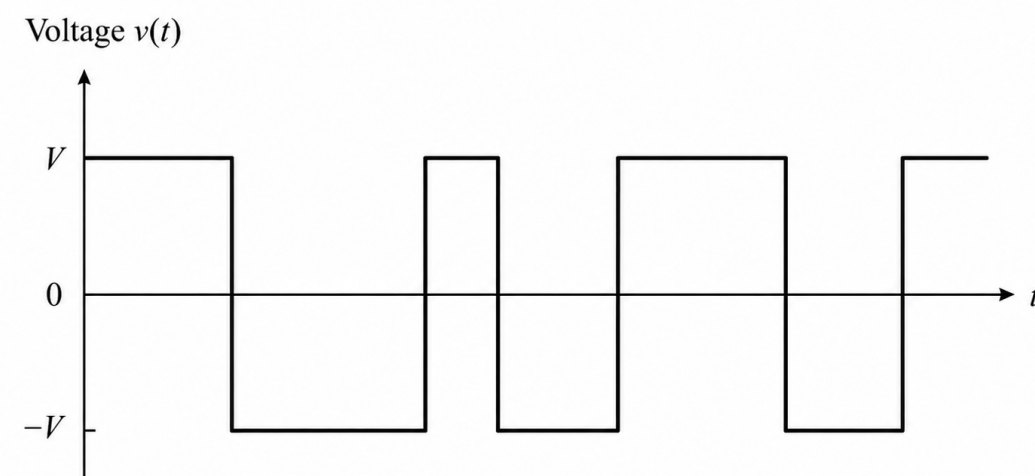

relay

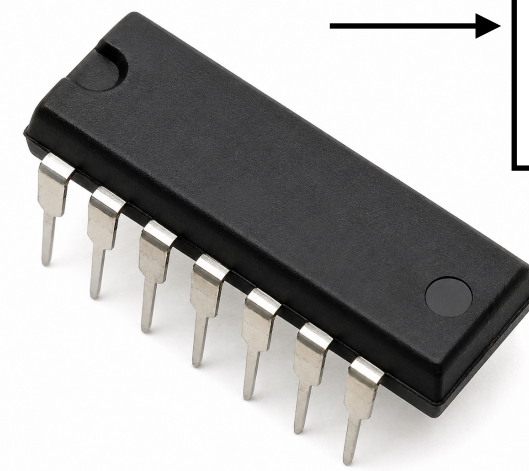

CMOS

Architecture

A computer architecture is  
“the design principle”  
that organizes how an abstract computation is  
embedded into physical dynamics.

Elementary logic gates  
AND, OR, NOT, NAND

Arithmetic • Memory access  
ADD, MUL, SHIFT, STORE, BRANCH....

Classical Digital Computation

input:  $x \in \{0,1\}^n$

↓ Boolean function  $f$

output:  $f(x)$

Trigonometric function, and more  
complicated algorithms...

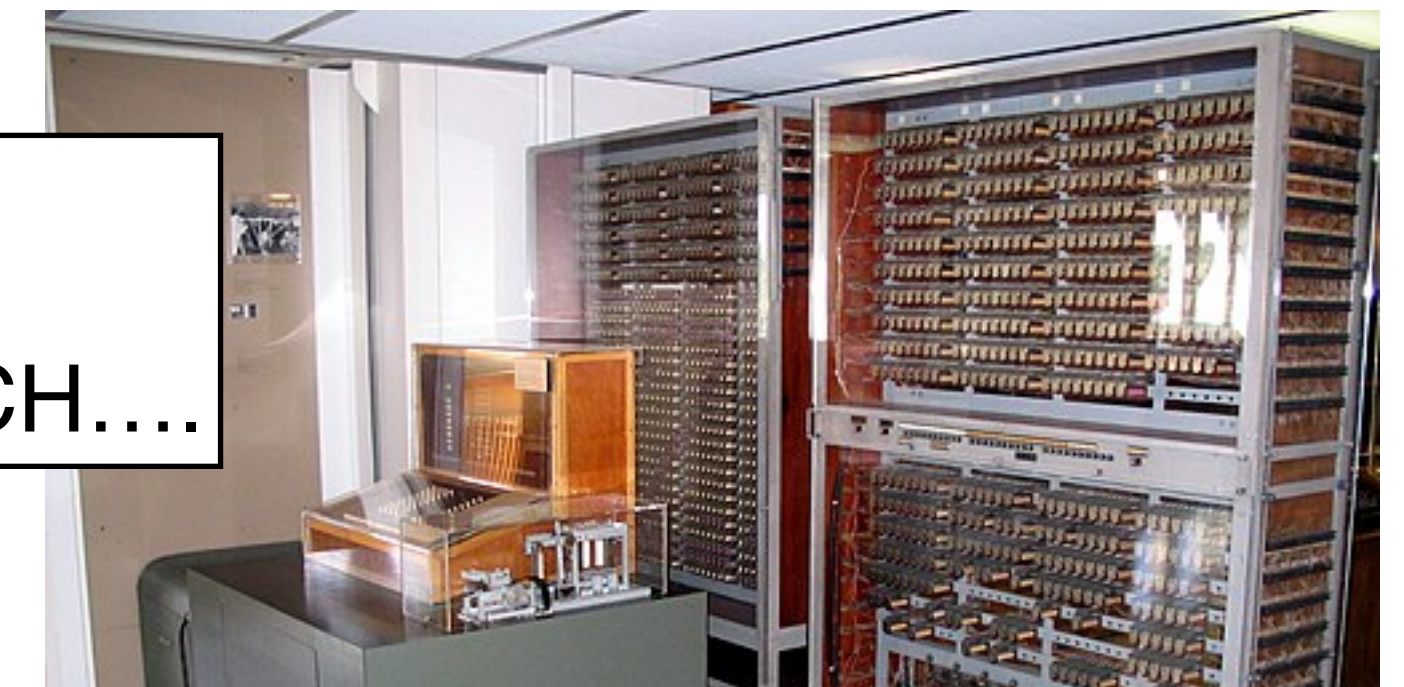

# What is “Computing Machine”?

A computing machine is a physical system that embeds an abstract problem-solving process into physical dynamics.

Physical Phenomena

electric voltage/current/switch

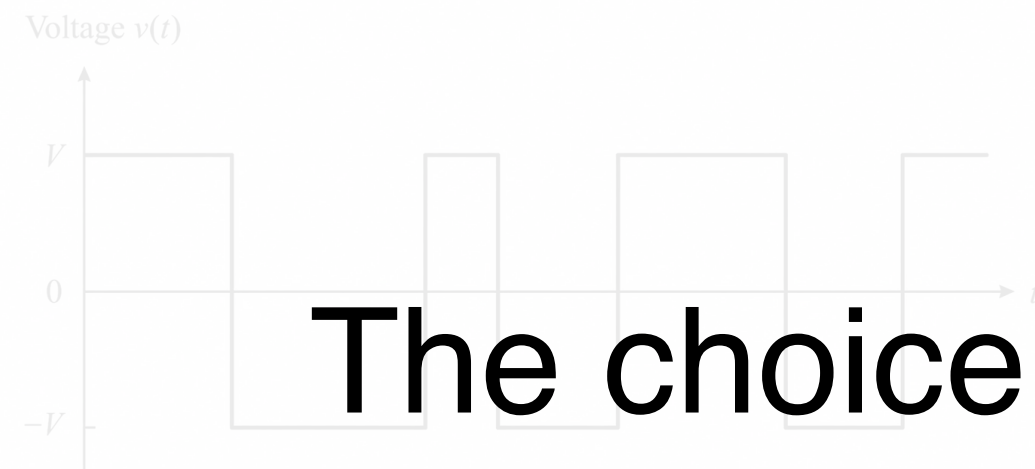

The choice of architecture (design principle) highly depends on available physical resources and computational goals.

Architecture

A computer architecture is “the design principle” that organizes how an abstract computation is embedded into physical dynamics.

Elementary logic gates  
AND, OR, NOT, NAND

Arithmetic • Memory access

ADD, MUL, SHIFT, STORE, BRANCH....

Classical Digital Computer

input:  $x \in \{0,1\}^n$

↓ Boolean function  $f$

output:  $f(x)$

Trigonometric function, and more complicated algorithms...

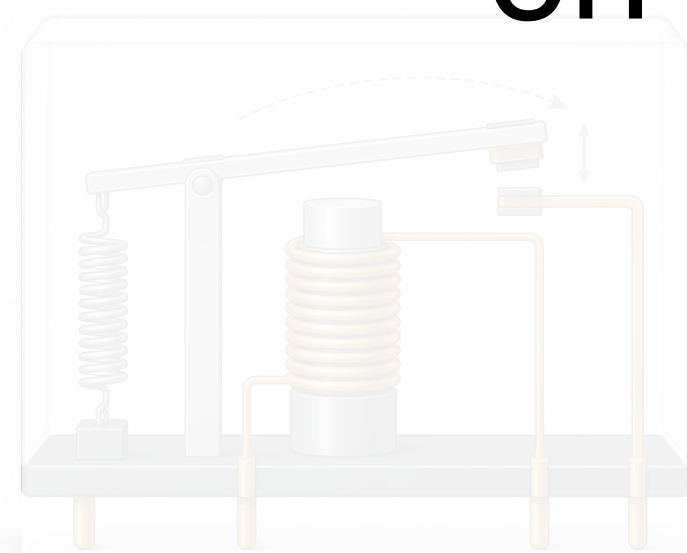

relay

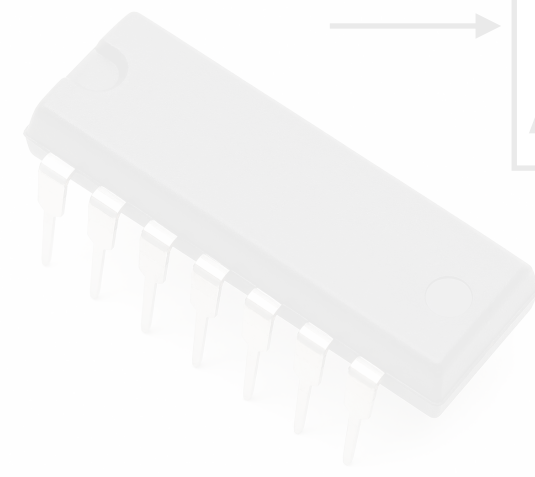

CMOS



# CORDIC: Coordinate Rotation Digital Computer

J. E. Volder, "The CORDIC Trigonometric Computing Technique" (1959)

Trigonometric computations require multiplication and addition, but **MUL** is much more expensive than **ADD** or **bit SHIFT**.

$$\begin{pmatrix} x' \\ y' \end{pmatrix} = \begin{pmatrix} \cos \theta & -\sin \theta \\ \sin \theta & \cos \theta \end{pmatrix} \begin{pmatrix} x \\ y \end{pmatrix} = \cos \theta \begin{pmatrix} 1 & -\tan \theta \\ \tan \theta & 1 \end{pmatrix} \begin{pmatrix} x \\ y \end{pmatrix}$$

$$\theta \simeq \sum_k d_k \underbrace{\arctan(2^{-k})}_{\theta_k}$$

$$d_k \in \{-1, +1\}$$

$$\theta_0 = \arctan(2^{-0}) = \pi/4 = 0.785398$$

$$\theta_1 = \arctan(2^{-1}) = 0.463648$$

$$\theta_2 = \arctan(2^{-2}) = 0.244979$$

$$\theta_3 = \arctan(2^{-3}) = 0.124355$$

$$\tilde{x}_{k+1} = x_k - d_k 2^{-k} y_k$$

$$\tilde{y}_{k+1} = y_k + d_k 2^{-k} x_k$$

Update (unnormalized) can be done by using **ADD** and **bit SHIFT**!

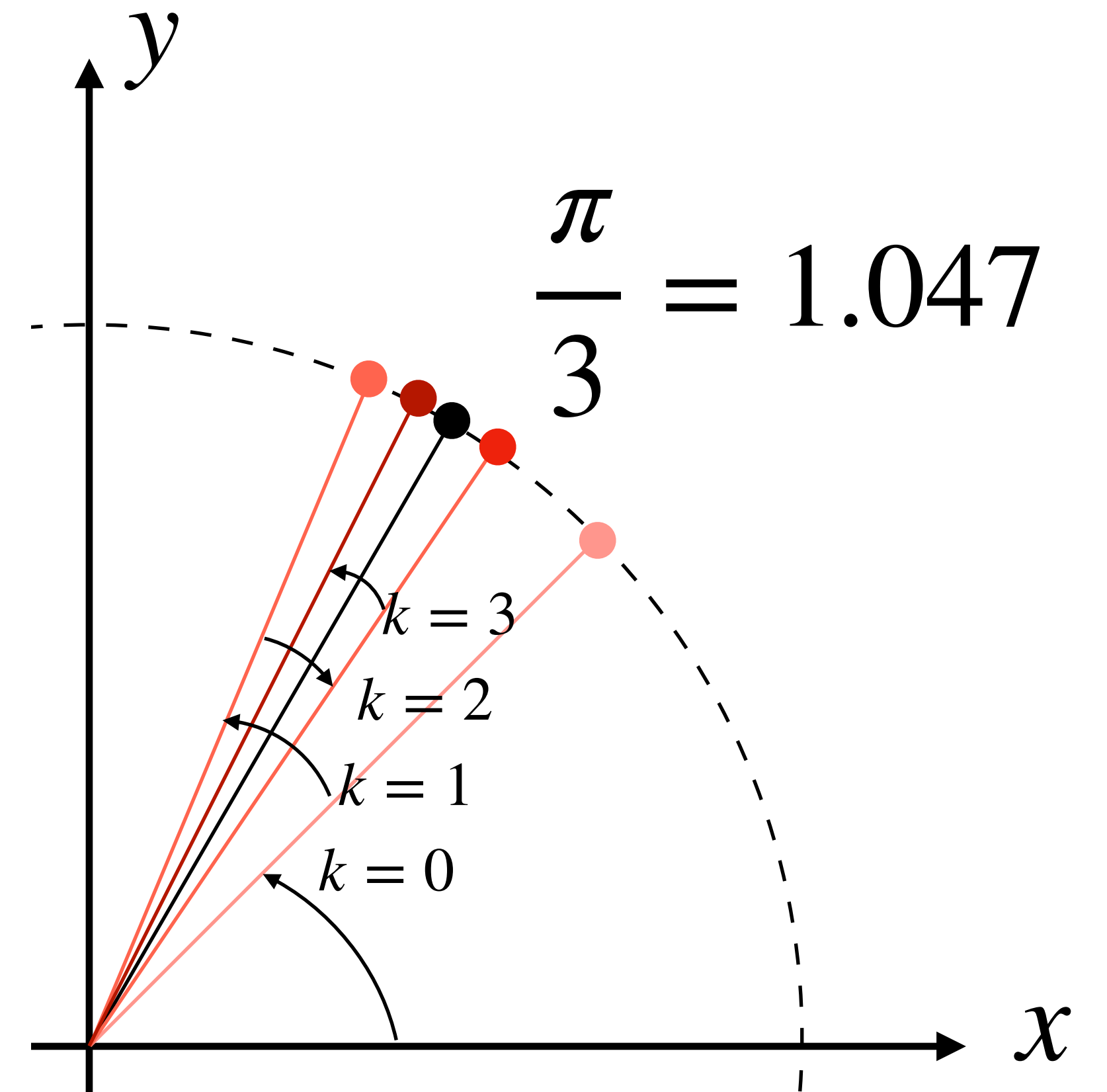

**Novel architectures emerge from physical constraints and computation-specific optimization!**

# CORDIC: Coordinate Rotation Digital Computer

J. E. Volder, "The CORDIC Trigonometric Computing Technique" (1959)

## CORDIC Is All You Need

OMKAR KOKANE, NSDCS Lab, Indian Institute of Technology Indore, India

ADAM TEMAN, EnICS Labs, Bar Ilan University, Israel

ANUSHKA JHA\* and GURU PRASATH SL\*, Indian Institute of Technology Indore, India

GOPAL RAUT† and MUKUL LOKHANDE†, NSDCS Lab, Indian Institute of Technology Indore, India

S. V. JAYA CHAND\* and TANUSHREE DEWANGAN\*, Indian Institute of Technology Indore, India

SANTOSH KUMAR VISHVAKARMA, NSDCS Lab, Indian Institute of Technology Indore, India

Artificial intelligence necessitates adaptable hardware accelerators for efficient high-throughput million operations. We present pipelined architecture with CORDIC block for linear MAC computations and nonlinear iterative Activation Functions (AF) such as tanh, *sigmoid*, and SoftMax. This approach focuses on a Reconfigurable Processing Engine (RPE) based systolic array, with 40% pruning rate, enhanced throughput up to 4.64×, and reduction in power and area by 5.02 × and 4.06 × at CMOS 28 nm, with minor accuracy loss. FPGA implementation achieves a reduction of up to 2.5 × resource savings and 3 × power compared to prior works. The Systolic CORDIC engine for Reconfigurability and Enhanced throughput (SYCore) deploys an output stationary dataflow with the CAESAR control engine for diverse AI workloads such as Transformers, RNNs/LSTMs, and DNNs for applications like image detection, LLMs, and speech recognition. The energy-efficient and flexible approach extends the enhanced approach for edge AI accelerators supporting emerging workloads.

No  
U  
] 4 Mar 2025

7

x  
on!

# What about quantum computer architecture?

## Physical Phenomena

quantum or neutral atoms on superconducting qubits, trapped ions, photons etc

*Adaptive time window  
Mishima et al arXiv:2605.14637*

quantum computer architecture

## Logical operations

Lattice surgery, Transversal gate, magic state distillation

## Elementary Logical gates

Hadamard, CNOT, T

## Problems

XQW ZQO XQW ZQO  
QFZ ZYF YMF QWZ  
LJXJQF ZQO LWTF  
YMF XQWJ QFZ QOOF  
ZQO ZYF CWZMJI

Factoring

Algorithms

(Shor's algorithm)

$$T = e^{-i(\pi/8)Z}$$

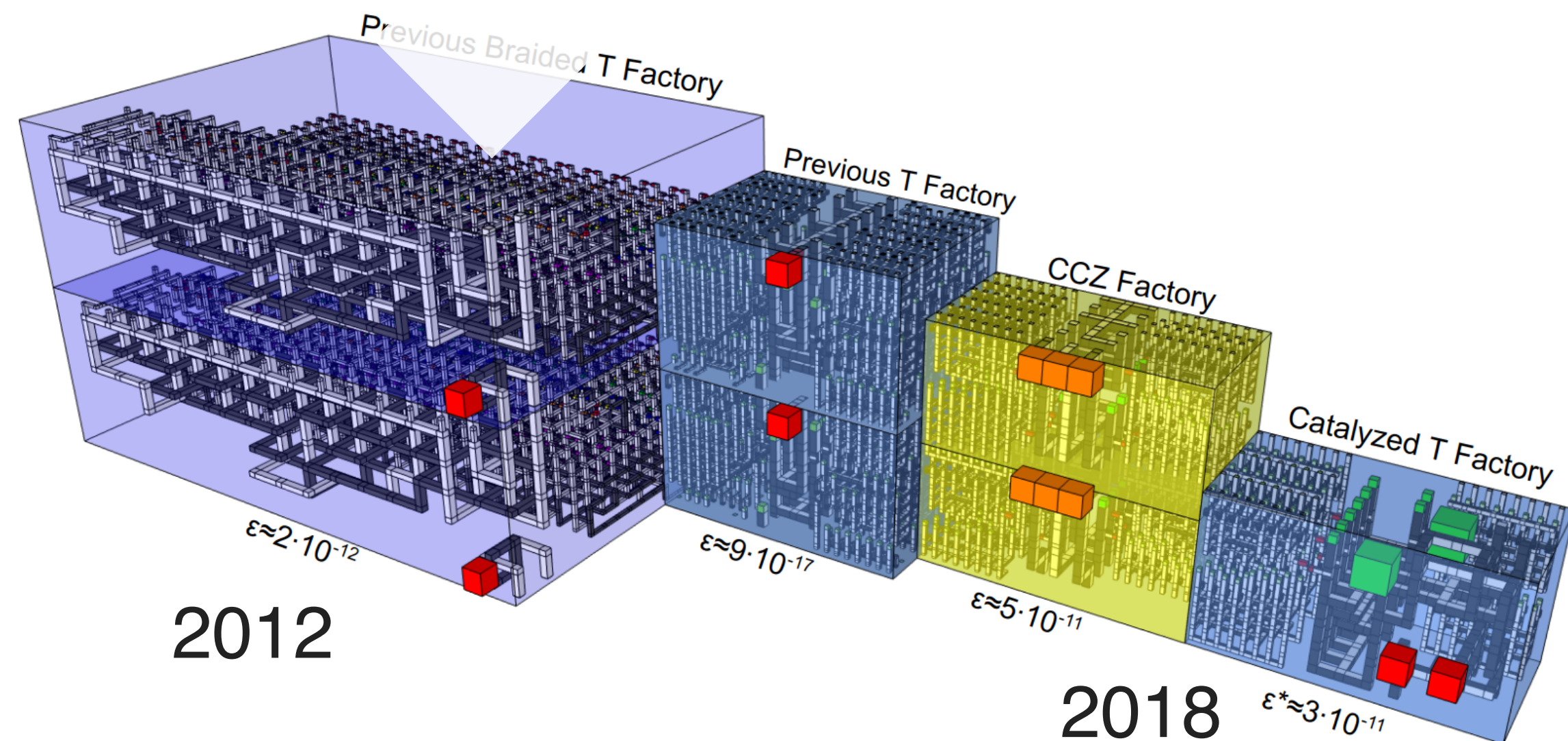

# Qubits required for solving RSA2048

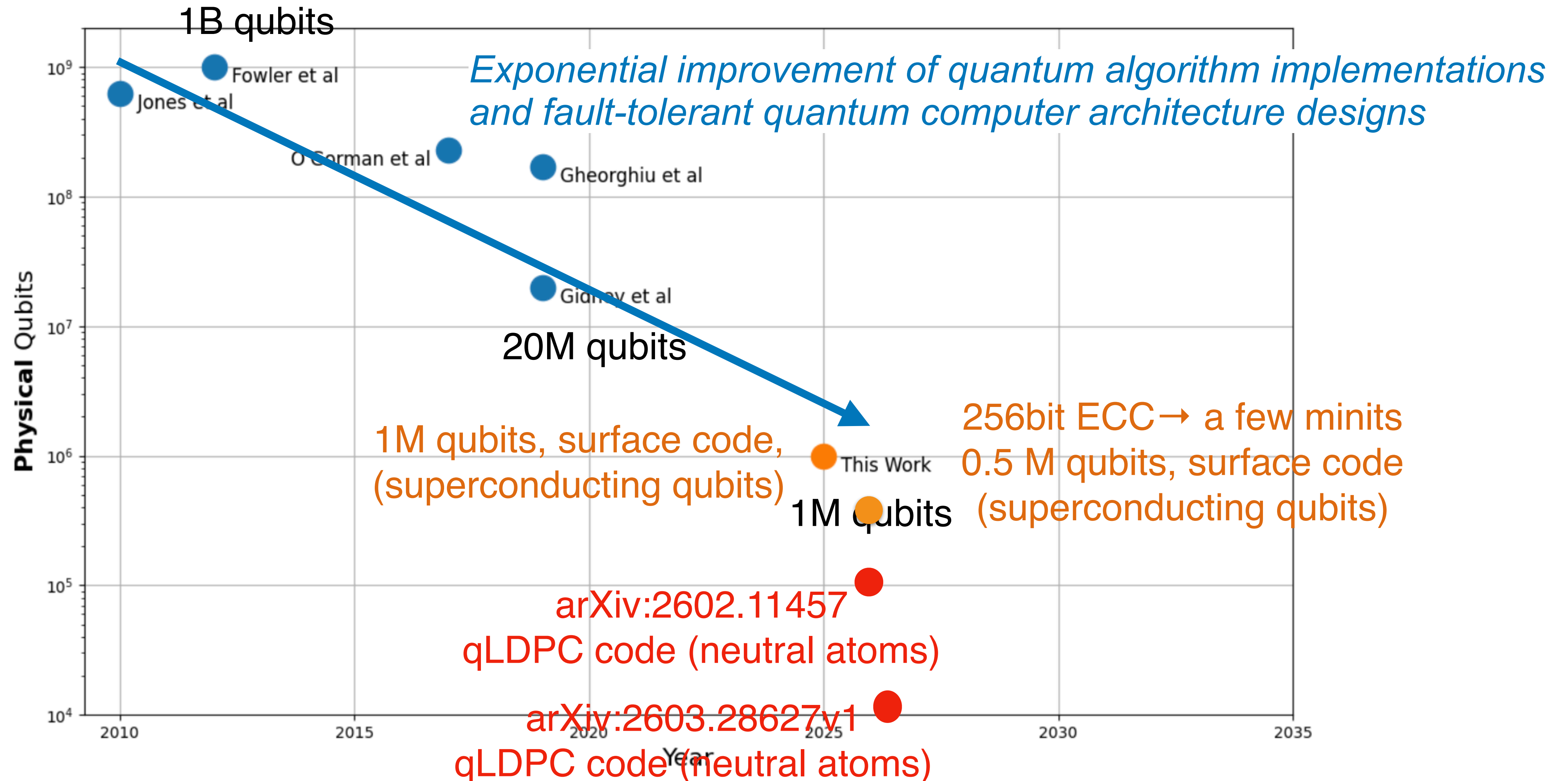

# What about quantum computer architecture?

## Physical Phenomena

quantum operations on superconducting qubits, neutral atoms, trapped ions, photons etc

## Problems

Quantum Simulation (Chemistry, CondMatPhys, HEP)

## quantum computer architecture

### QEC

surface code,  
qLDPC code,  
syndrome  
measurements

### Logical operations

Lattice surgery, Transversal  
gate, ~~magic state distillation~~  
???????

### Elementary Logical gates

??????

### Algorithms

Hamiltonian simulation  
with Trotterization

# Outline

- Introduction: what is computing machine and what is the role of architecture
- Overview of the STAR architecture
- Ver1: space-time efficient analog rotation
- Ver2: error reduction by transversal rotations and postselection
- Ver3: STAR magic mutation



# What is a bottleneck for (digital) quantum simulation

Hamiltonian simulation requires many small-angle rotations:

- Hamiltonian:  $H = A + B$
- Time evolution:  $U(t) = e^{-iHt} = e^{-i(A+B)t}$
- Trotter expansion:  $e^{-i(A+B)t} = \left( e^{-iA\frac{t}{N}} e^{-iB\frac{t}{N}} \right)^N + O\left(\frac{t^2}{N} \|[A, B]\| \right)$

ex) transverse Ising model:  $H_{\text{Ising}} = \sum_{ij} J_{ij} Z_i Z_j + \sum_i h_i X_i$

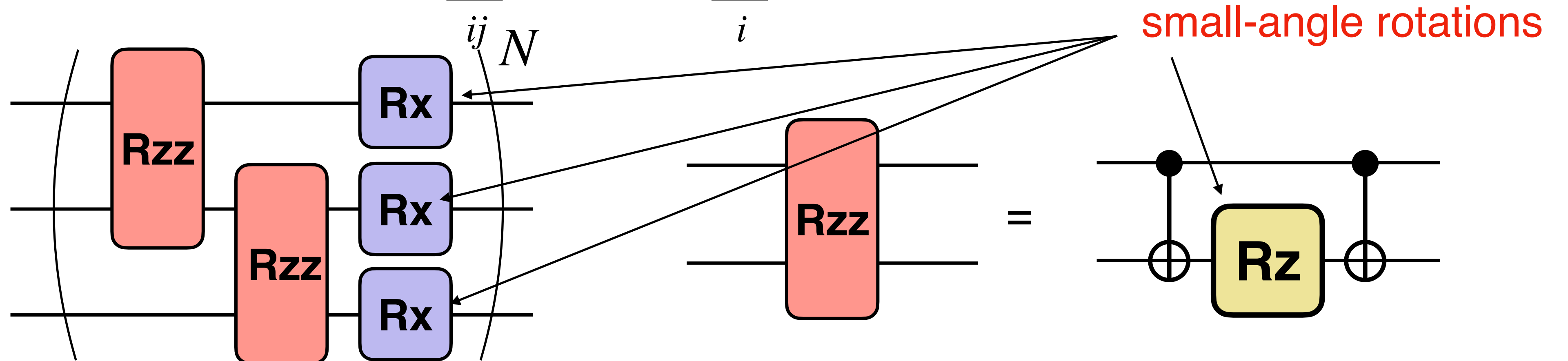

A large number of small-angle rotation gates are required!



# Partially Fault-tolerant Quantum Computing Architecture

Y Akahoshi, K Maruyama, H Oshima, S Sato, KF, PRX Quantum 5, 010337 (2024).

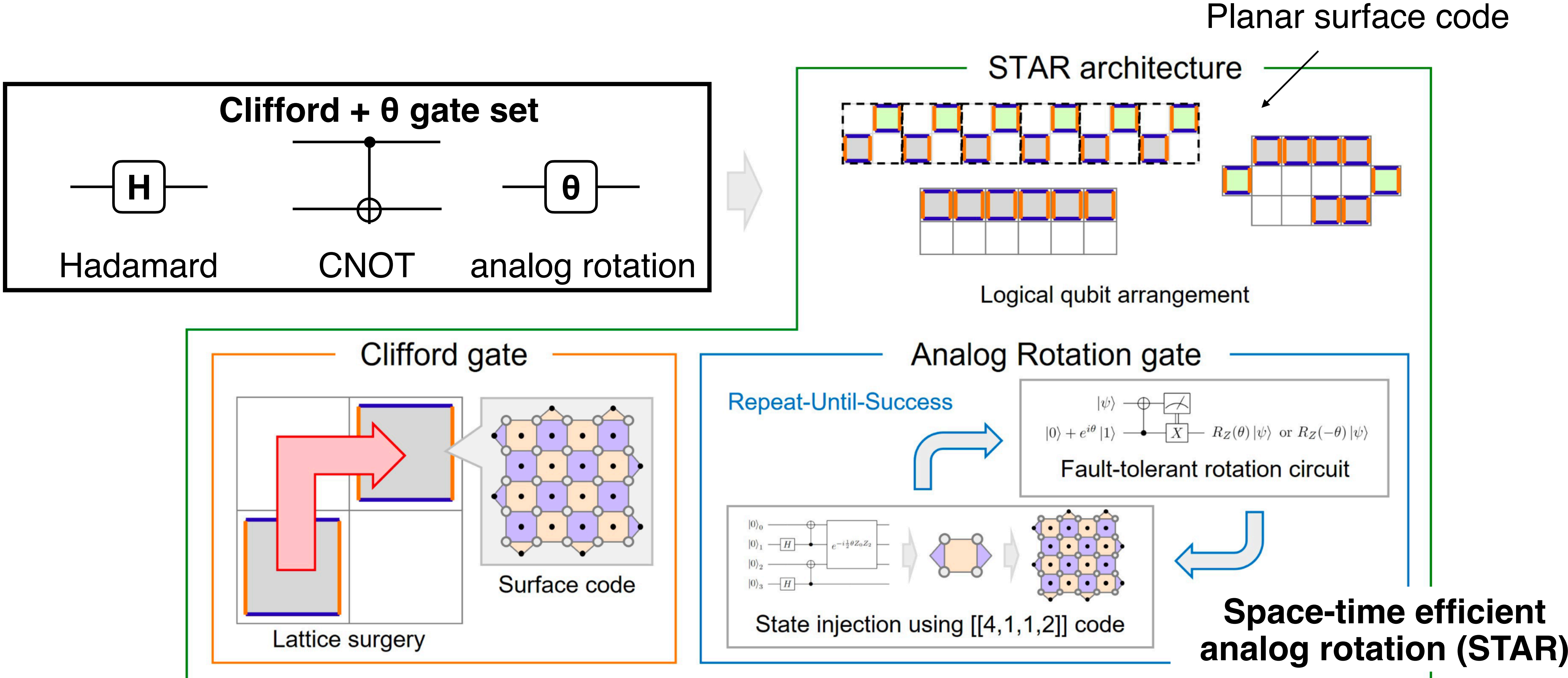

Clifford gates are fully protected.

1Q rotations are not protected but fairly accurate.

# Outline

- Introduction: what is computing machine and what is the role of architecture

- Overview of the STAR architecture

- Ver1: space-time efficient analog rotation

*“Partially Fault-tolerant Quantum Computing Architecture with Error-corrected Clifford Gates and Space-time Efficient Analog Rotations”*  
Y Akahoshi, K Maruyama, H Oshima, S Sato, KF, PRX Quantum (2024).

- Ver2: error reduction by transversal rotations and postselection

*"Practical quantum advantage on partially fault-tolerant quantum computer."*  
R Toshio, Y Akahoshi, J Fujisaki, H Oshima, S Sato, KF, Phys. Rev. X (2025).

- Ver3: STAR magic mutation

**[NEW]** *“STAR-Magic Mutation: Even More Efficient Analog Rotation Gates for Early Fault-Tolerant Quantum Computer”*  
R Toshio, S. Kanasugi, J Fujisaki, H Oshima, S Sato, KF, arXiv:2603.2289.

# STAR (space-time efficient analog rotation) architectures

Ver. 1

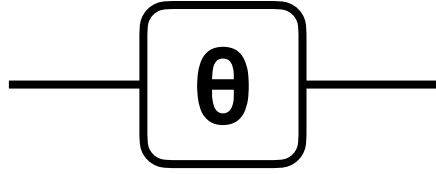

analog rotation

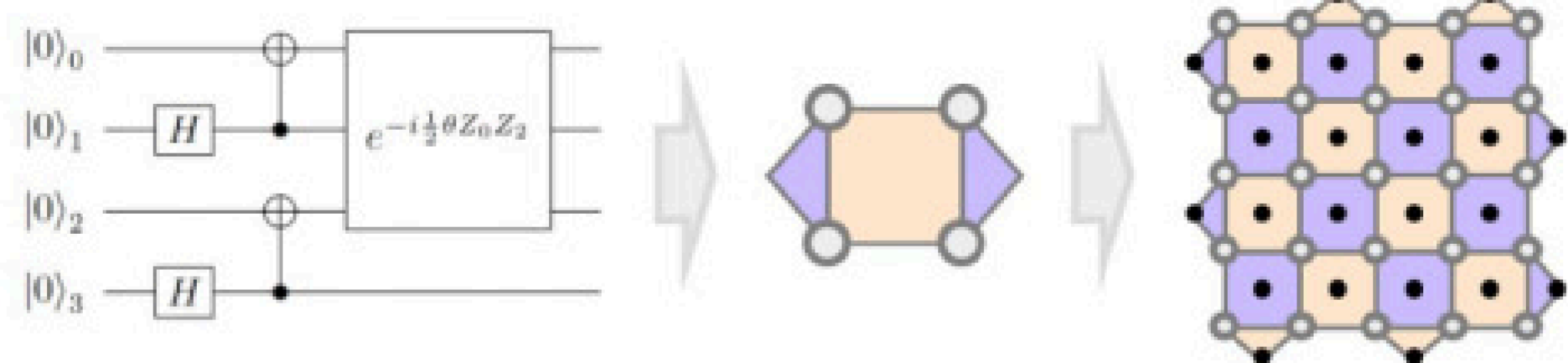

[[4,2,2]] code (error detection):  $p_\theta = O(p)$

universal gate sets

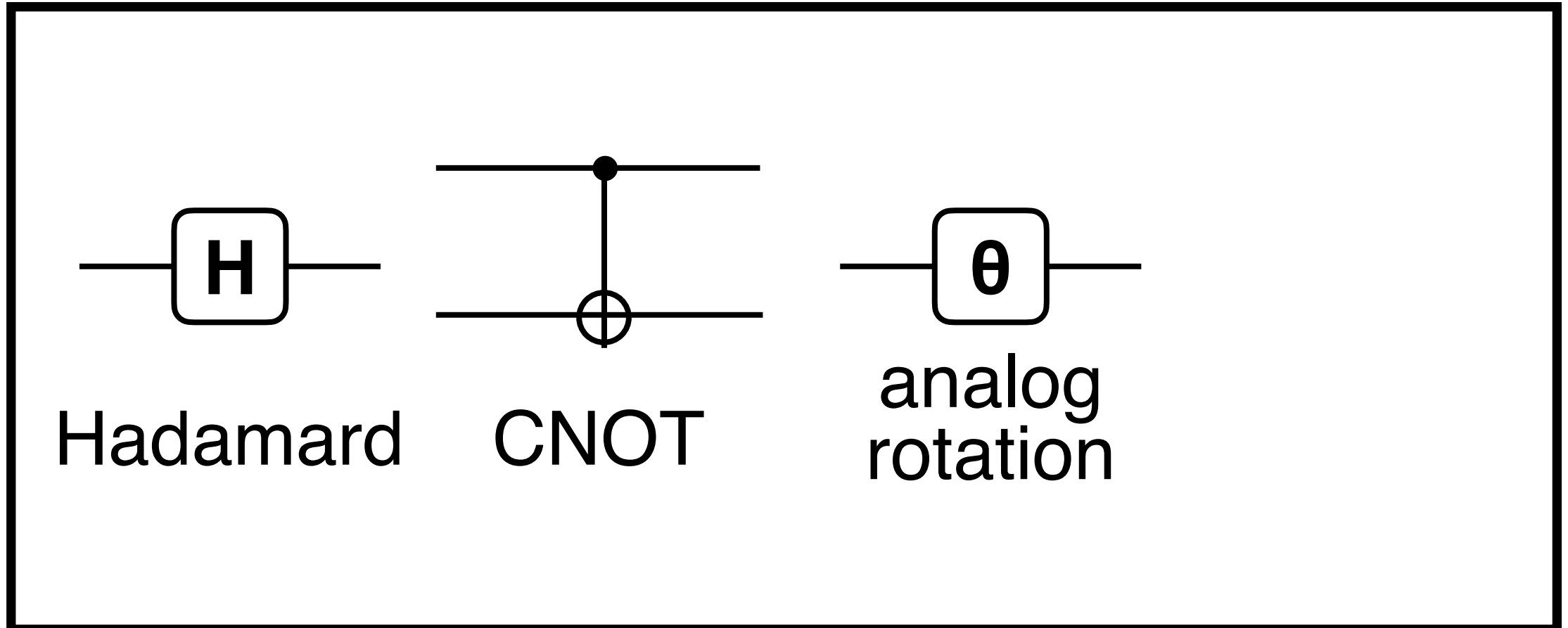

physical error rate:  $p = 10^{-3} - 10^{-4}$

# Partially Fault-tolerant Quantum Computing Architecture

Y Akahoshi, K Maruyama, H Oshima, S Sato, KF, PRX Quantum 5, 010337 (2024).

## Ancilla injection with error detection

### Ancilla state generation for analog rotation gate

[[4, 1, 1, 2]] code

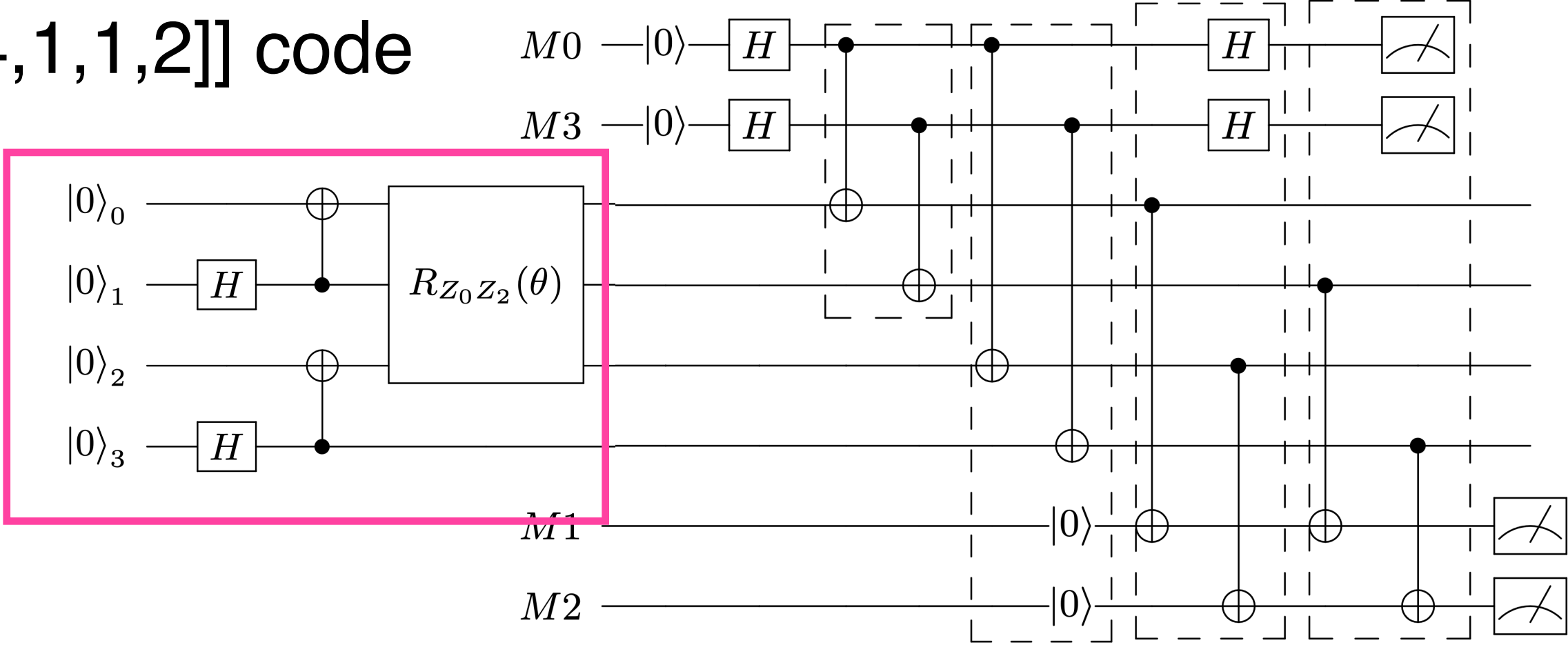

$$\frac{1}{\sqrt{2}} (e^{-i\theta/2} |0\rangle + e^{+i\theta/2} |1\rangle)$$

Errors are detected and discarded except for unavoidable one

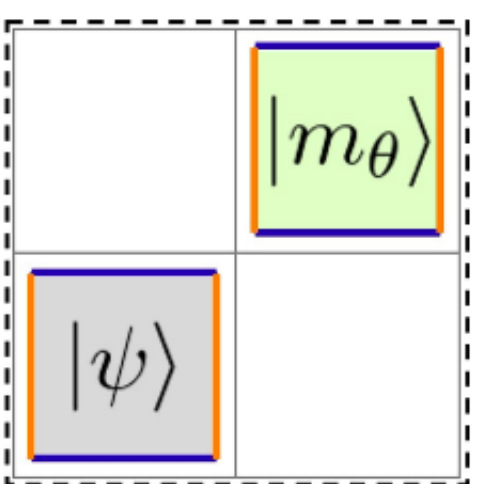

### Gauge fixing to surface code

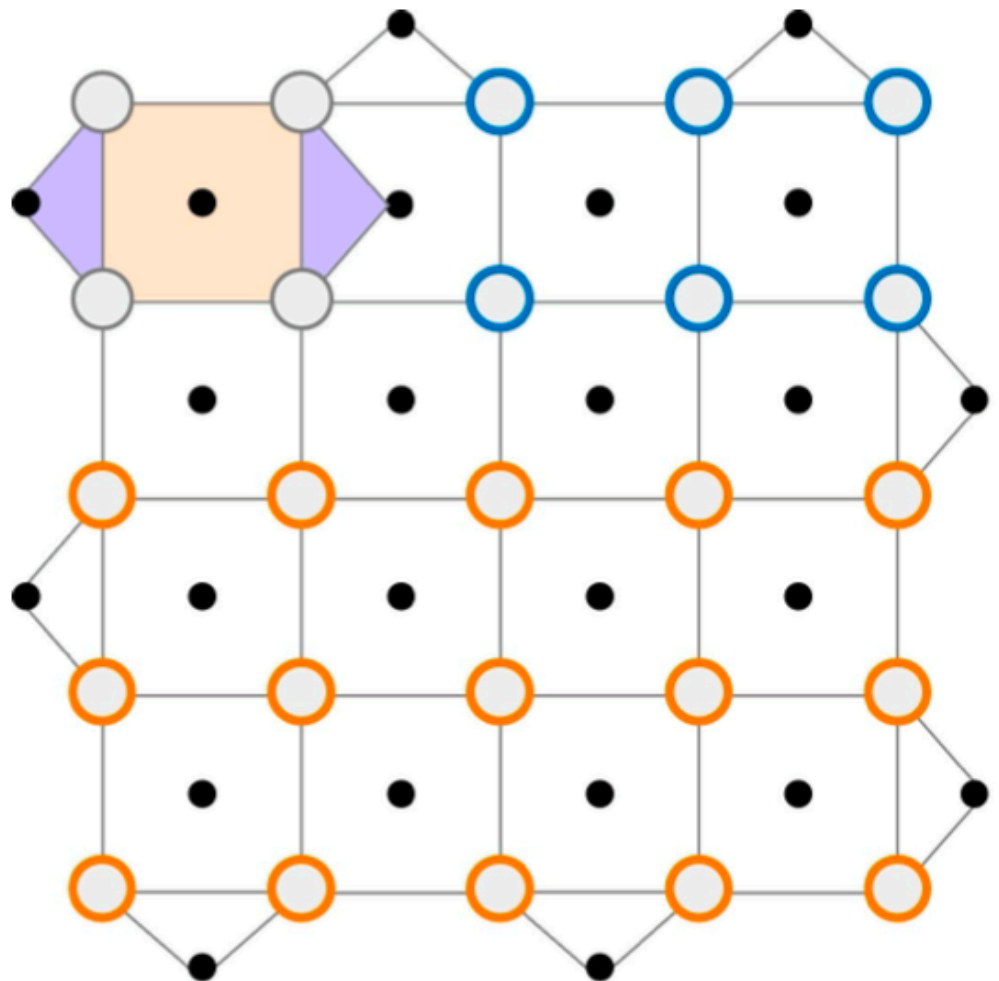

### Code Expansion

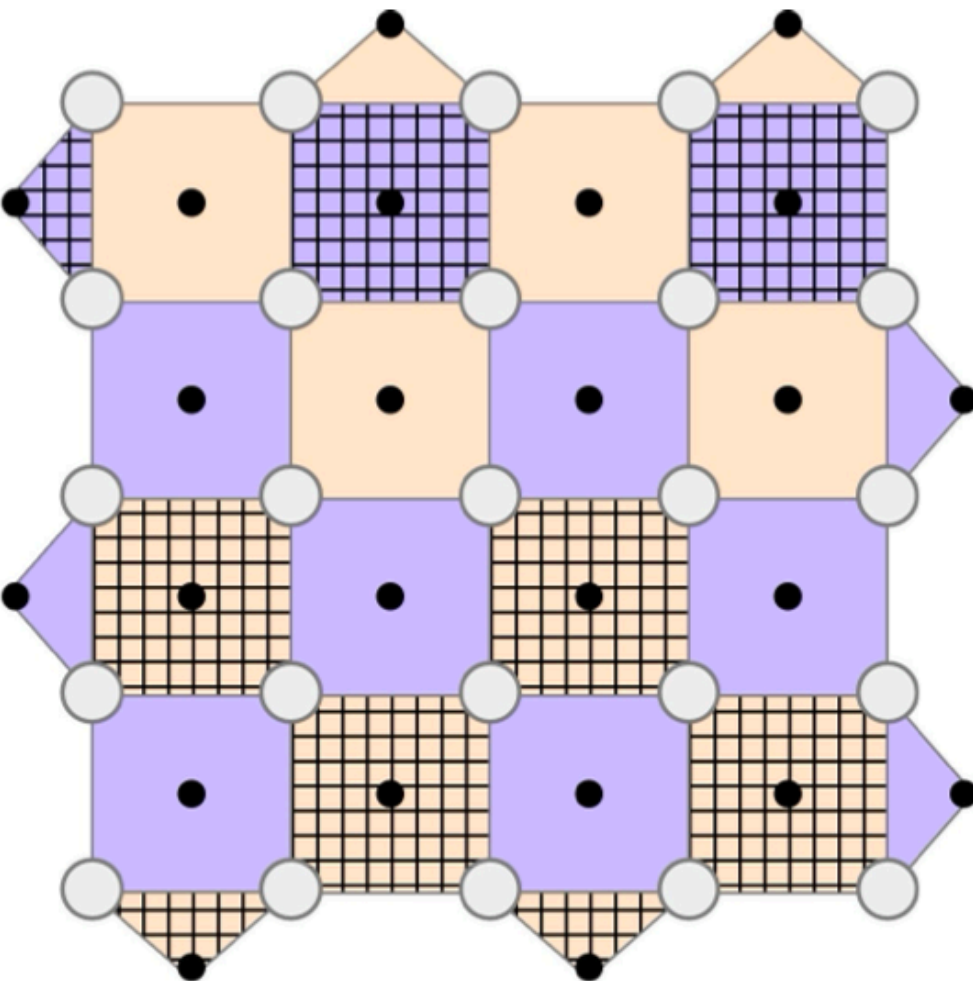

fully protected!

### Gate teleportation

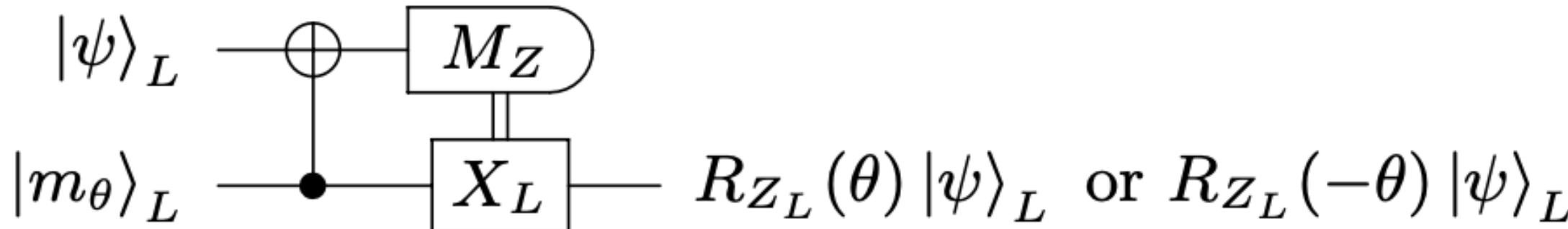

repeat until success

→ space-time efficient analog rotation (STAR) gate

# STAR (space-time efficient analog rotation) architectures

## universal gate sets

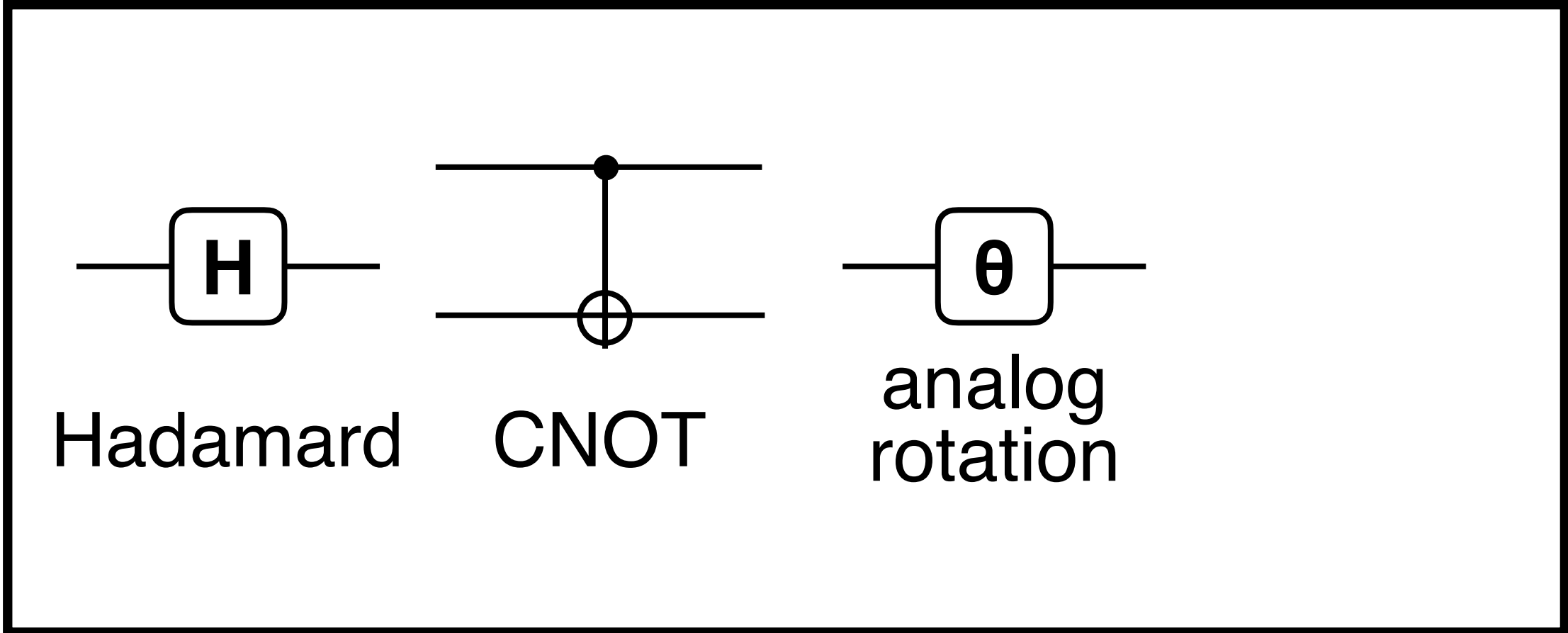

physical error rate:  $p = 10^{-3} - 10^{-4}$

### Ver. 1

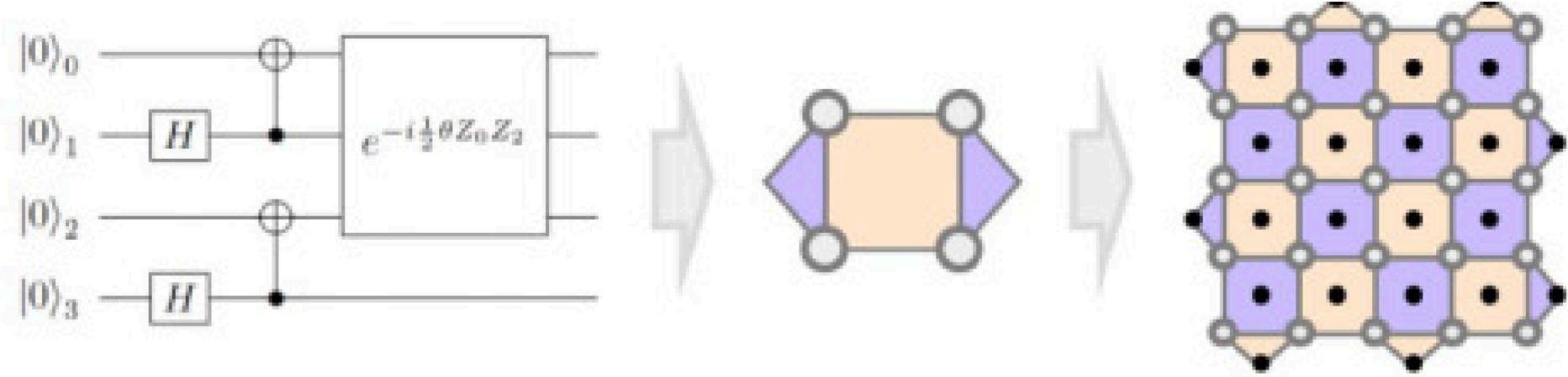
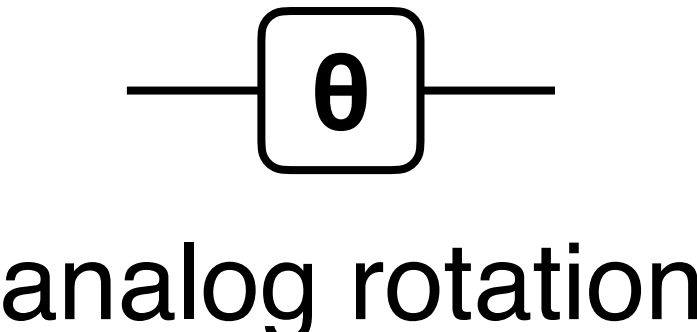

[[4,2,2]] code (error detection):  $p_\theta = O(p)$

### Ver. 2

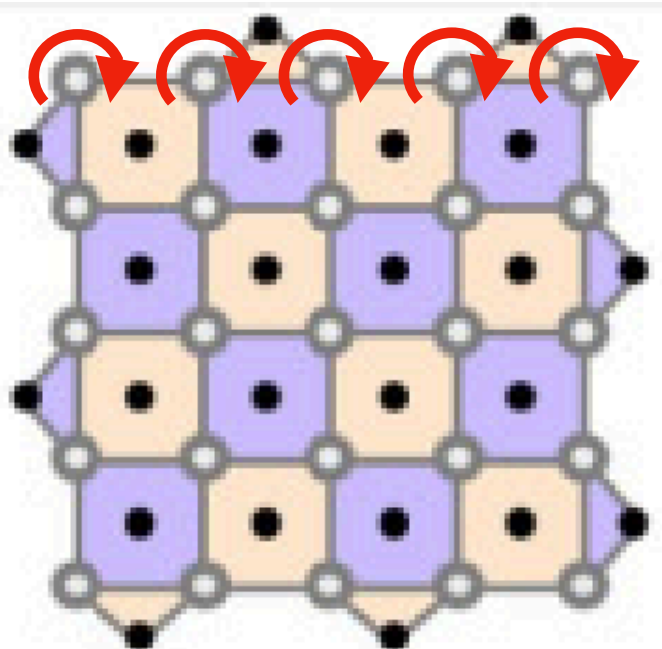
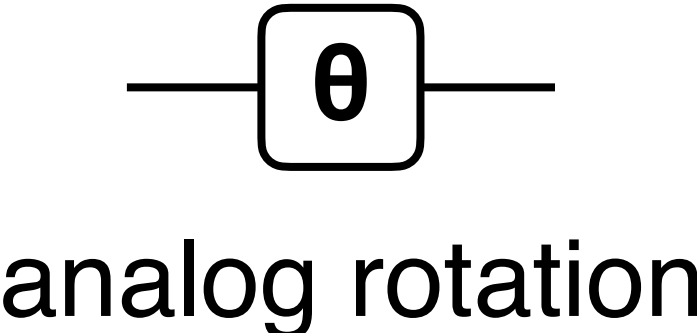

transversal analog rotation & postselection [Choi'23]

$$p_\theta = O(\theta p)$$

# Error reduction for small angle rotation gate

Choi et al. "Fault tolerant non-clifford state preparation for arbitrary rotations." arXiv:2303.17380.

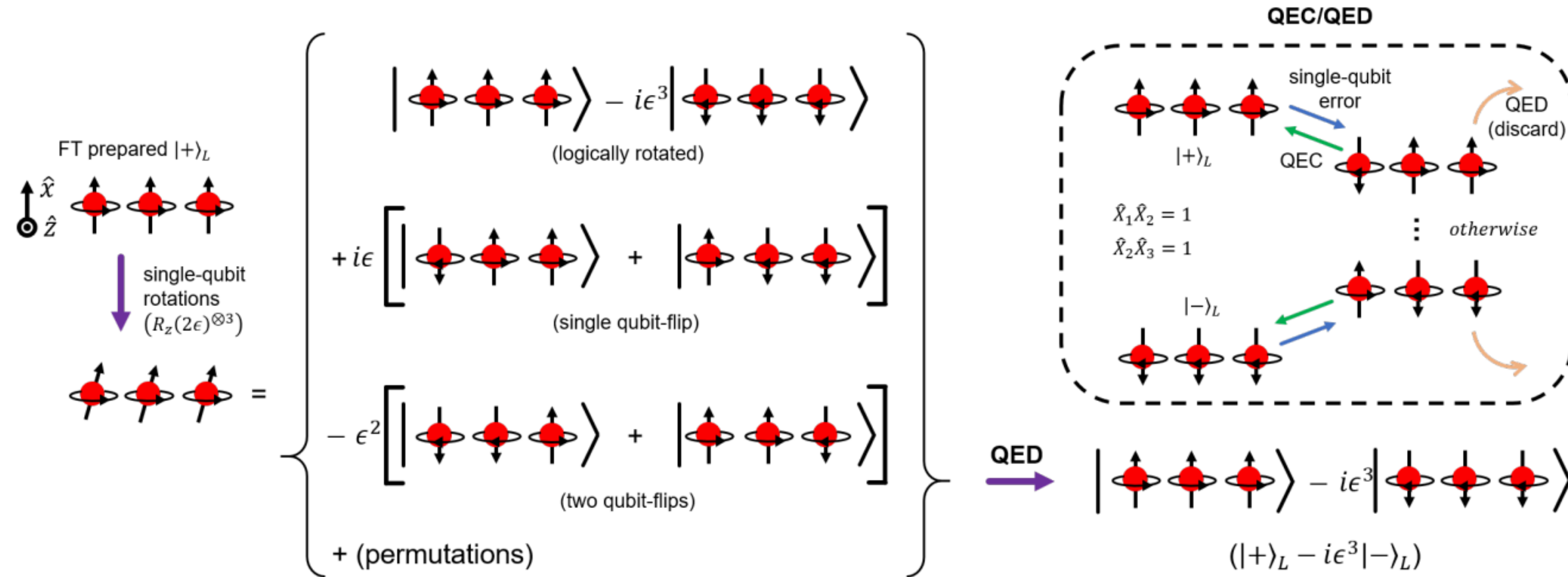

$$|+\rangle_L = |+++ \rangle$$

transversal  $R_z(\theta)$

$$\longrightarrow R_z(\theta)^{\otimes 3} |+\rangle_L = \cos^3(\theta) |+++ \rangle + i \sin^3(\theta) |--- \rangle + (\text{others such as } \cos^2(\theta)\sin(\theta) |++- \rangle)$$

$$\xrightarrow{\text{error detection \& postselection}} \frac{1}{\mathcal{N}} \cos^3(\theta) (|+++ \rangle + i \sin^3(\theta) |--- \rangle)$$

$$\text{Error rate} \rightarrow O(\theta^* p) \text{ where } \theta^* := \arcsin(\sin^3(\theta)/\mathcal{N})$$

# STAR (space-time efficient analog rotation) architectures

## universal gate sets

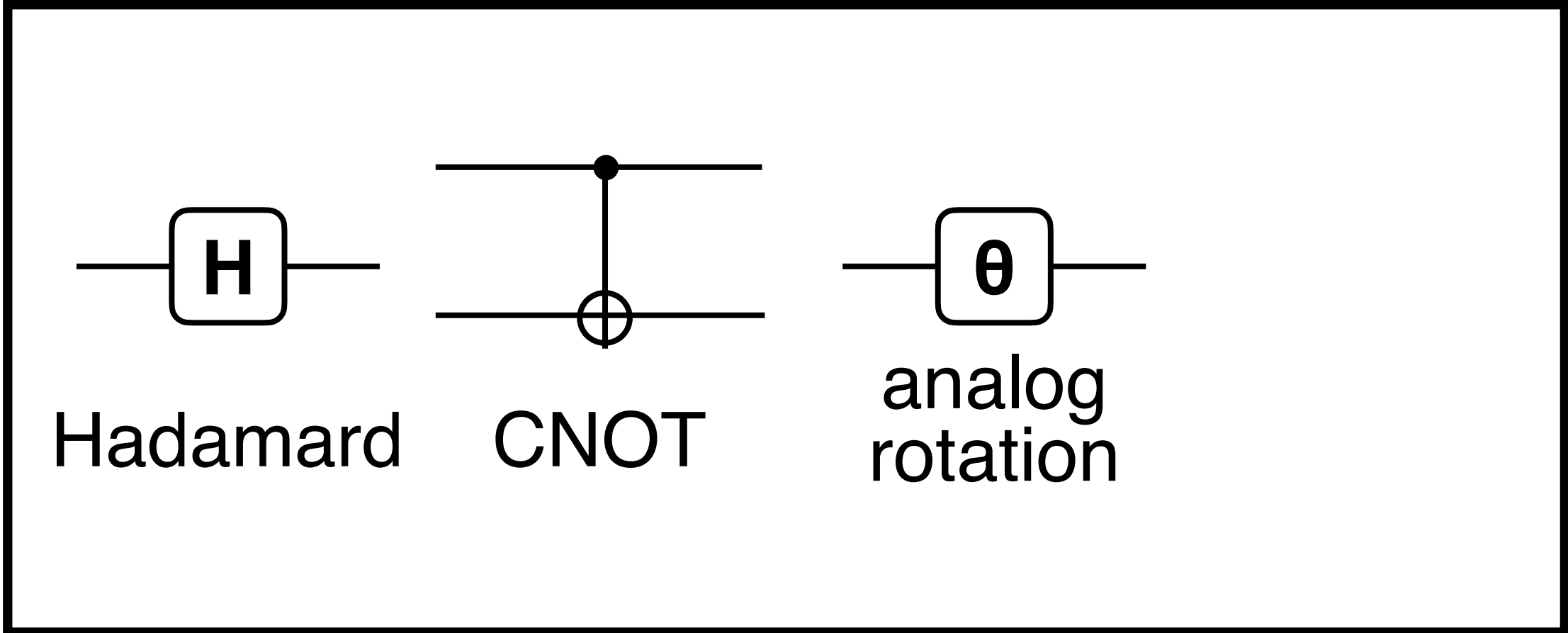

physical error rate:  $p = 10^{-3} - 10^{-4}$

### Ver. 1

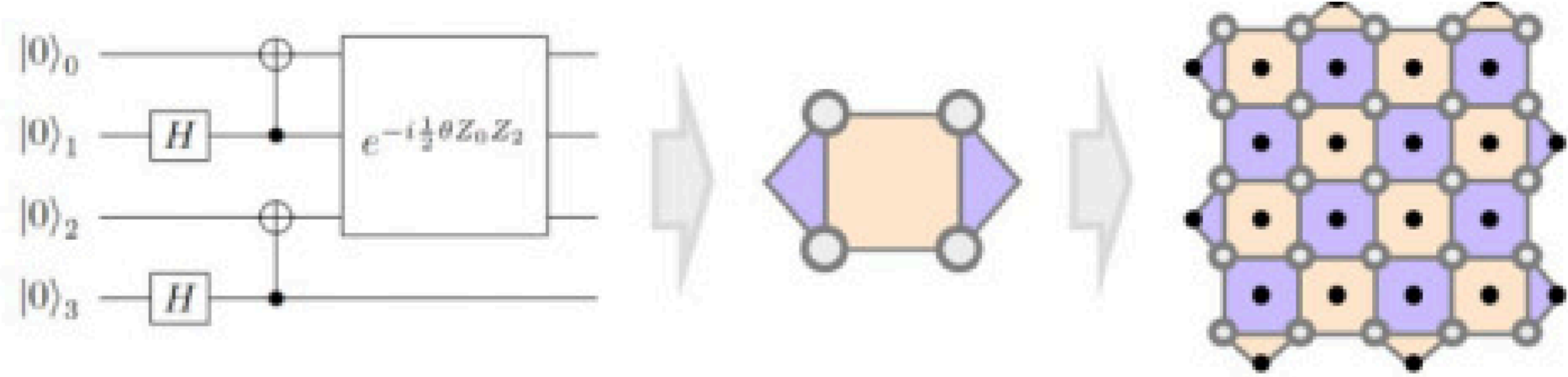
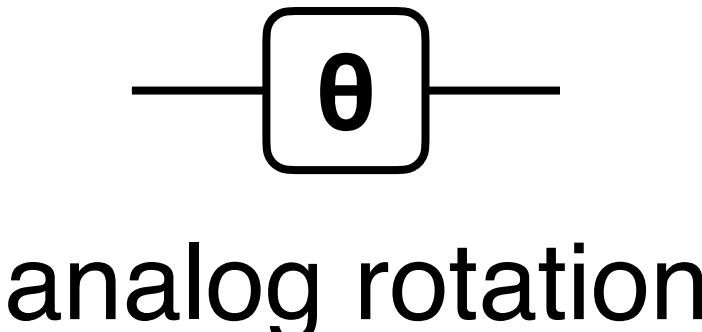

[[4,2,2]] code (error detection):  $p_\theta = O(p)$

### Ver. 2

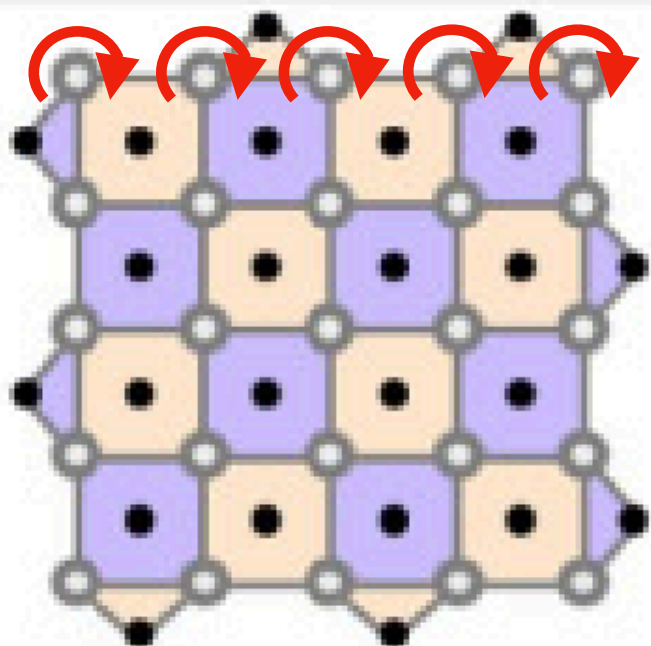
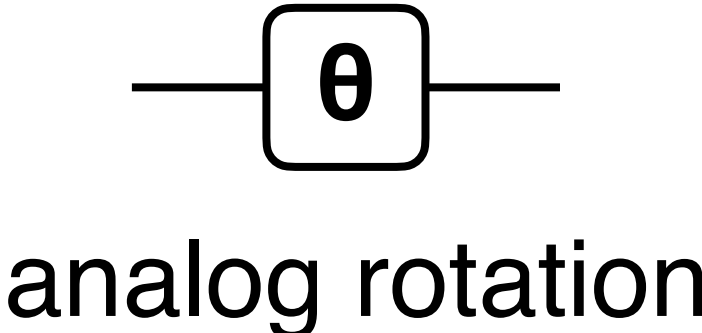

transversal analog rotation & postselection [Choi'23]

$$p_\theta = O(\theta p)$$

ex)  $\theta \sim 10^{-3}, p \sim 10^{-4} \rightarrow p_\theta \sim 10^{-7} !!$

# Resource Estimation for Practically Important Tasks

2D ( $L,L$ ) site Hubbard model:

$$H = -\frac{t}{2} \sum_{\langle i,j \rangle, \sigma} \hat{c}_{i\sigma}^\dagger \hat{c}_{j\sigma} + \frac{U}{4} \sum_i \hat{n}_{i\uparrow} \hat{n}_{i\downarrow}$$

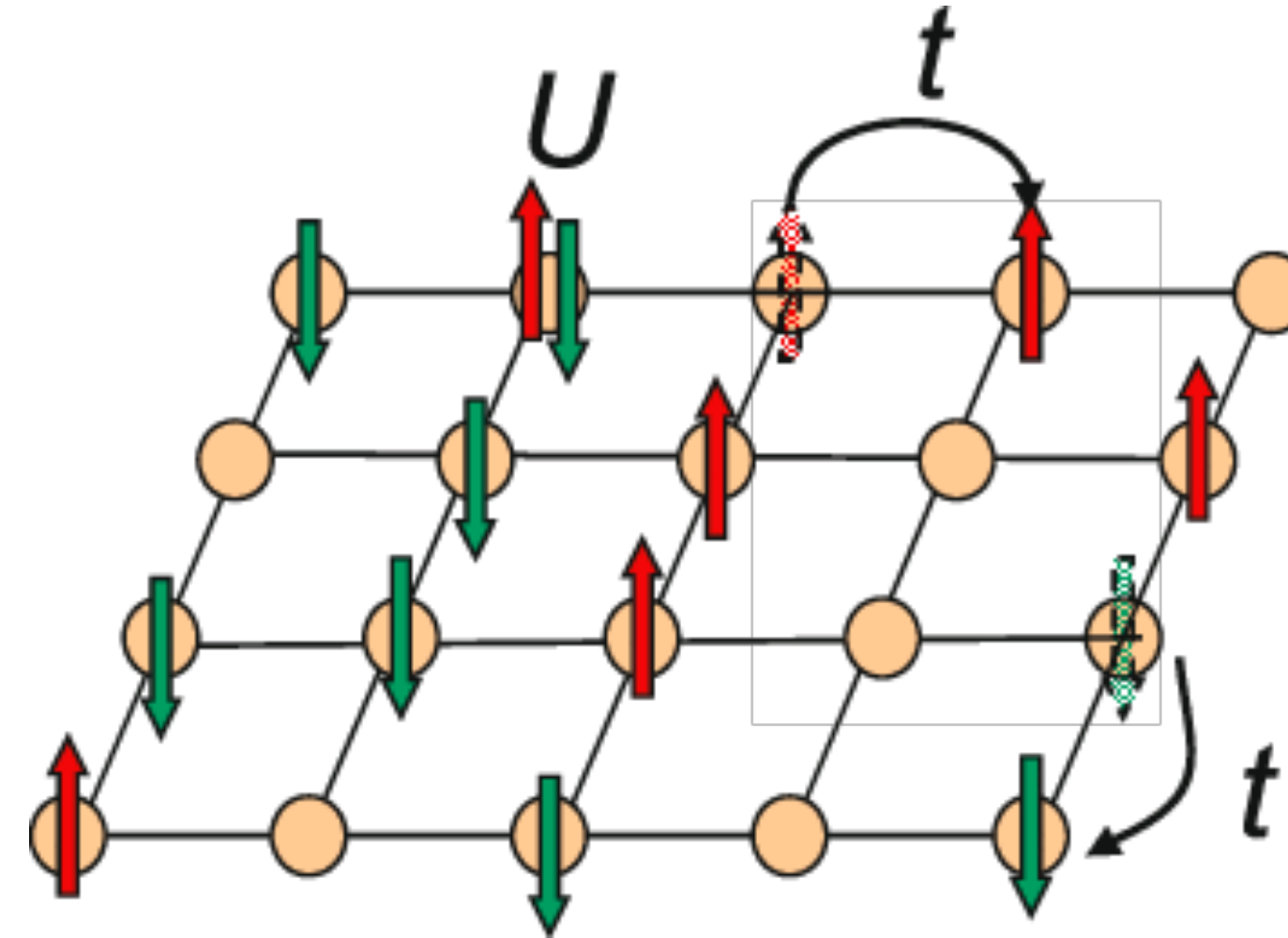

<https://upload.wikimedia.org/wikipedia/commons/a/a8/2D-Hubbard-model.png>

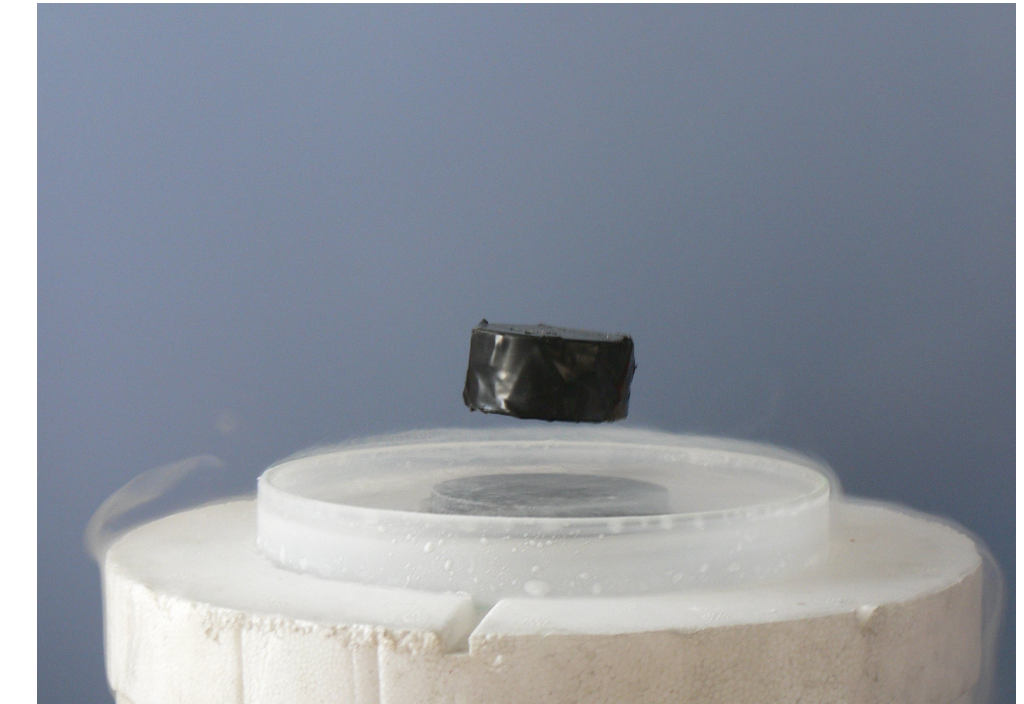

<https://ja.wikipedia.org/wiki/%E8%B6%85%E4%BC%9D%E5%B0%8E>

Overhead for solving  $L \times L$  Hubbard model:

Problem size		Code distance		Physical qubits		Execution time (hours)	
Lattice size	Data qubits	$p_{\text{ph}} = 10^{-3}$	$p_{\text{ph}} = 10^{-4}$	$p_{\text{ph}} = 10^{-3}$	$p_{\text{ph}} = 10^{-4}$	$p_{\text{ph}} = 10^{-3}$	$p_{\text{ph}} = 10^{-4}$
$6 \times 6$	73	23	11	$1.24 \times 10^5$	$2.83 \times 10^4$	$1.29 \times 10^3$	$7.88 \times 10^1$
$8 \times 8$	129	25	13	$2.51 \times 10^5$	$6.79 \times 10^4$	$3.26 \times 10^4$	$2.54 \times 10^2$
$10 \times 10$	201	25	13	$3.86 \times 10^5$	$1.04 \times 10^5$	$1.52 \times 10^6$	$6.00 \times 10^2$

**10 hours**

"Practical quantum advantage on partially fault-tolerant quantum computer."

R Toshio, Y Akahoshi, J Fujisaki, H Oshima, S Sato, KF, Phys. Rev. X (2025).

"Compilation of trotter-based time evolution for partially fault-tolerant quantum computing architecture"

Y Akahoshi, R Toshio, J Fujisaki, H Oshima, S Sato, KF, PRX Quantum (2025)

# STAR (space-time efficient analog rotation) architectures

## universal gate sets

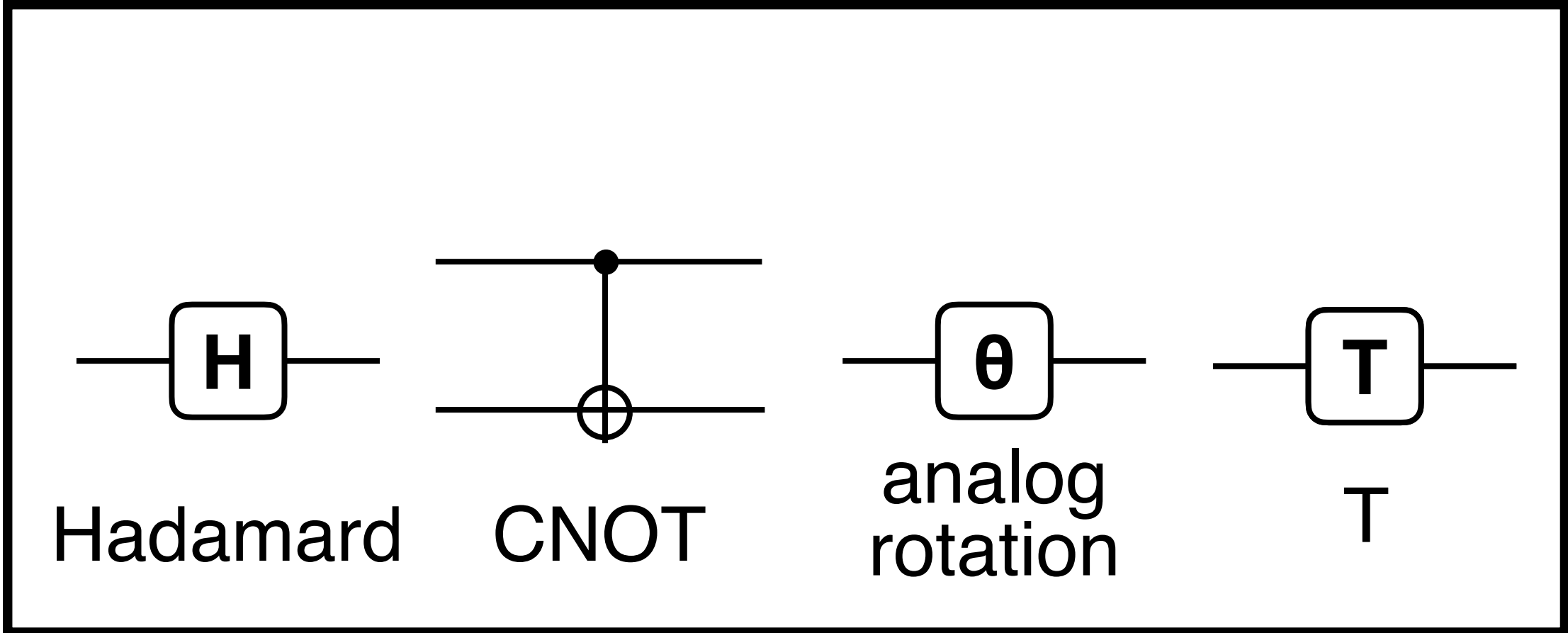

magic state cultivation [Gidney'25].  
space-time efficient magic state injection

### Ver. 1

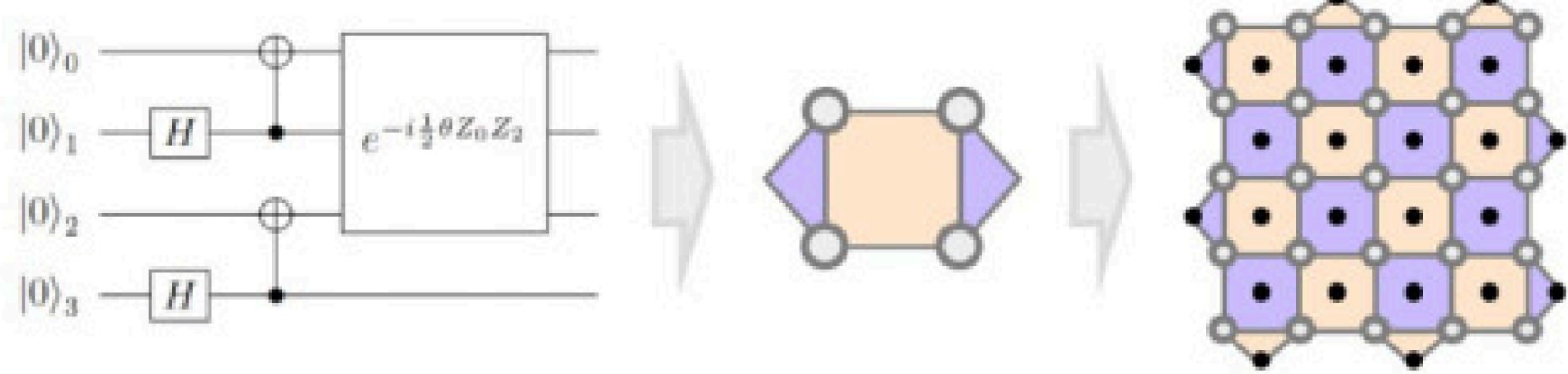
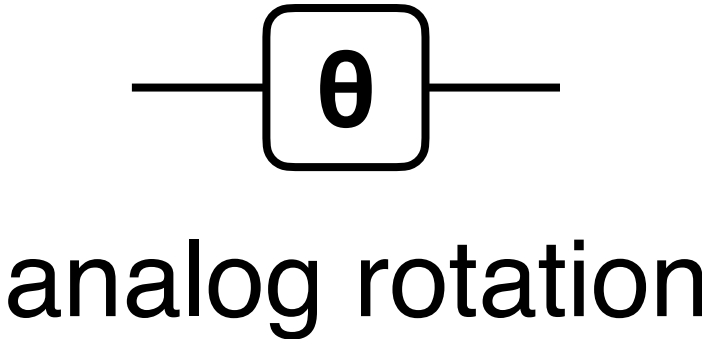

[[4,2,2]] code (error detection):  $p_\theta = O(p)$

### Ver. 2

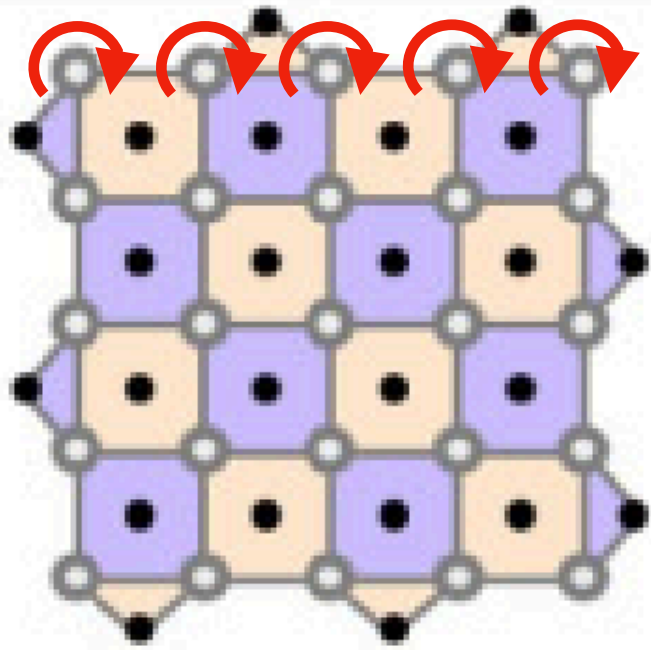
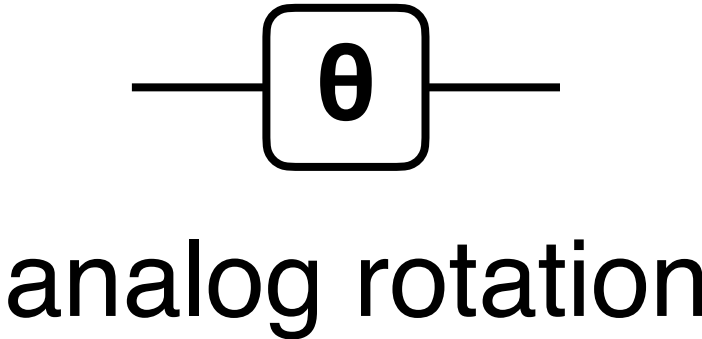

transversal analog rotation & postselection [Choi'23]

$$p_\theta = O(\theta p)$$

### Ver. 3 [NEW! arXiv:2603.22891]

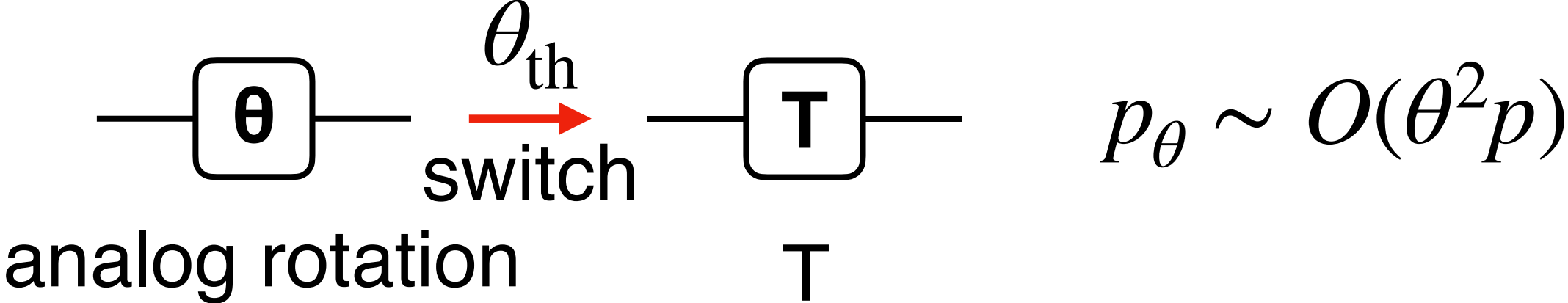

$$p_\theta \sim O(\theta^2 p)$$

ex)  $\theta \sim 10^{-3}, p \sim 10^{-3} \rightarrow p_\theta \sim 10^{-9} !!$

# STAR Magic Mutation

“STAR-Magic Mutation: Even More Efficient Analog Rotation Gates for Early Fault-Tolerant Quantum Computer”  
 R Toshio, S Kanasugi, J Fujisaki, H Oshima, S Sato, K Fujii, arXiv preprint arXiv:2603.22891

## Gate teleportation:

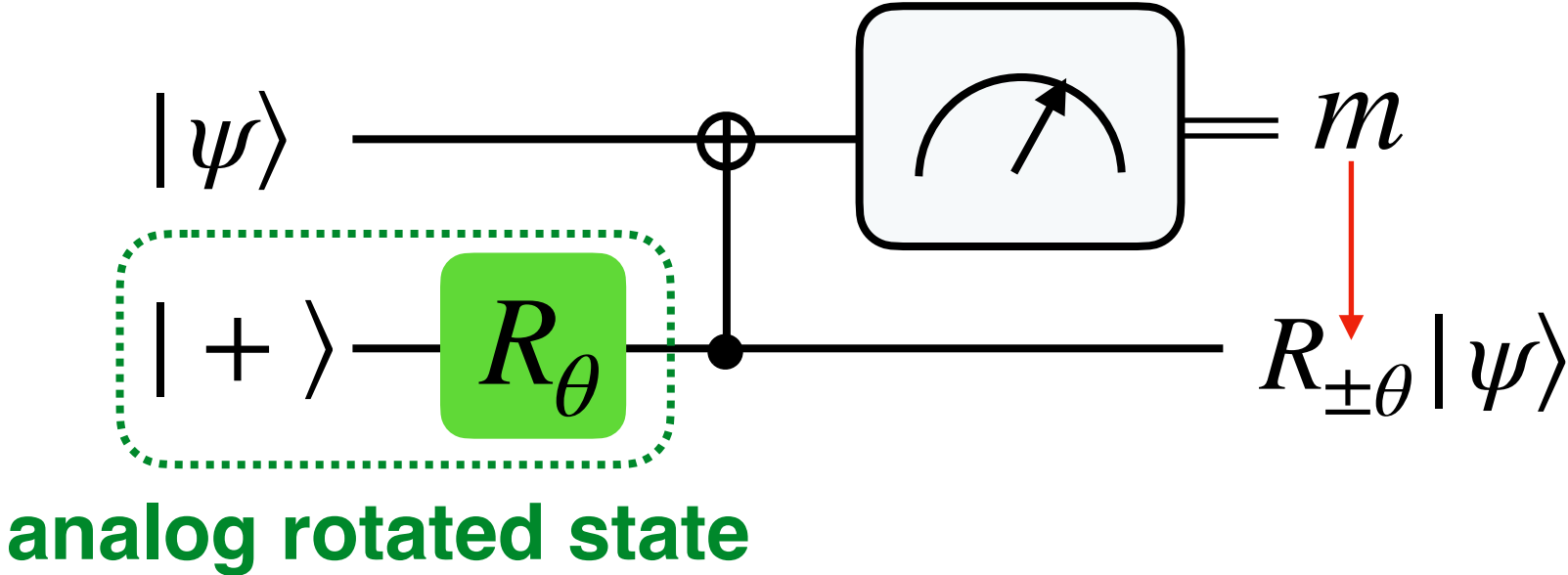

The measurement outcomes in teleportation are completely random  
 → Repeat Until Success (RUS)

## STAR architecture Ver. 3 [NEW!]

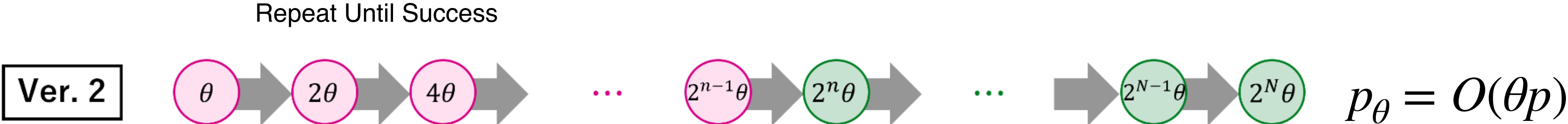

# Resource Estimate for Quantum Simulation

“STAR-Magic Mutation: Even More Efficient Analog Rotation Gates for Early Fault-Tolerant Quantum Computer “

R Toshio, S Kanasugi, J Fujisaki, H Oshima, S Sato, K Fujii, arXiv preprint arXiv:2603.22891

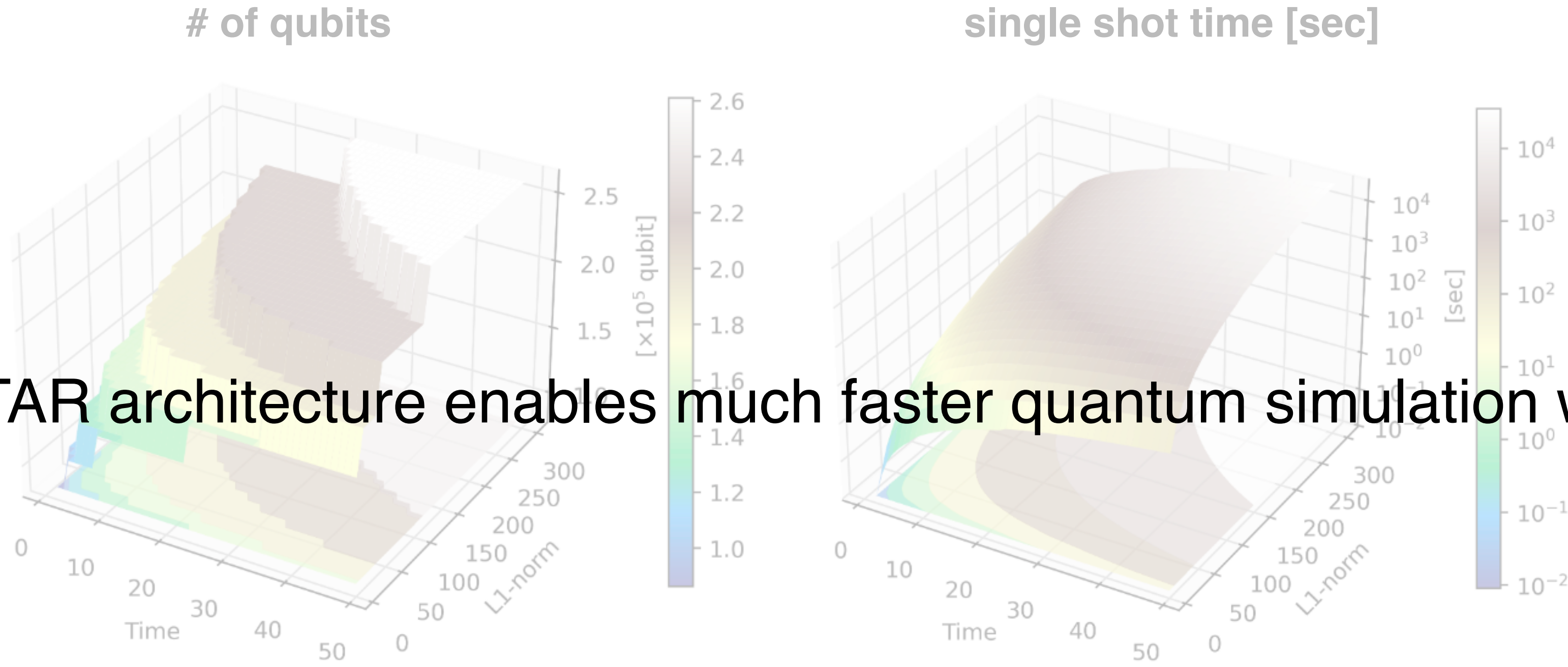

STAR architecture enables much faster quantum simulation with significantly fewer qubits.

L1-norm of Hamiltonian:  $\lambda$   
 time:  $T$ ,  
 coefficient:  $\alpha \sim 0.1$   
 physical error rate:  $p_{\text{ph}} = 10^{-3}$

$$\lambda T < \frac{1}{\alpha p_{\text{ph}}}$$

System	$\lambda$
$N$ -sites RFIC	$(3J + h/2)N$
$(L \times L)$ -sites TFIM	$(2J + h)L^2$
$(L \times L)$ -sites Hubba	$(4t + U/4)L^2$
[2Fe-2S] [55]	38.2 [Hartree]
[4Fe-4S] [55]	137.8 [Hartree]
FeMoco (S=0) [104]	308.2 [Hartree]
FeMoco (S=3/2) [10]	512.5 [Hartree]

See also: Kanasugi et al arXiv:2603.22778 for resource estimation on quantum phase estimation.

Enabling quantum simulation of practically relevant molecules with  $\sim 10^5$  qubits, a tens-fold reduction vs. conventional methods.

# Summary

## Ver. 1

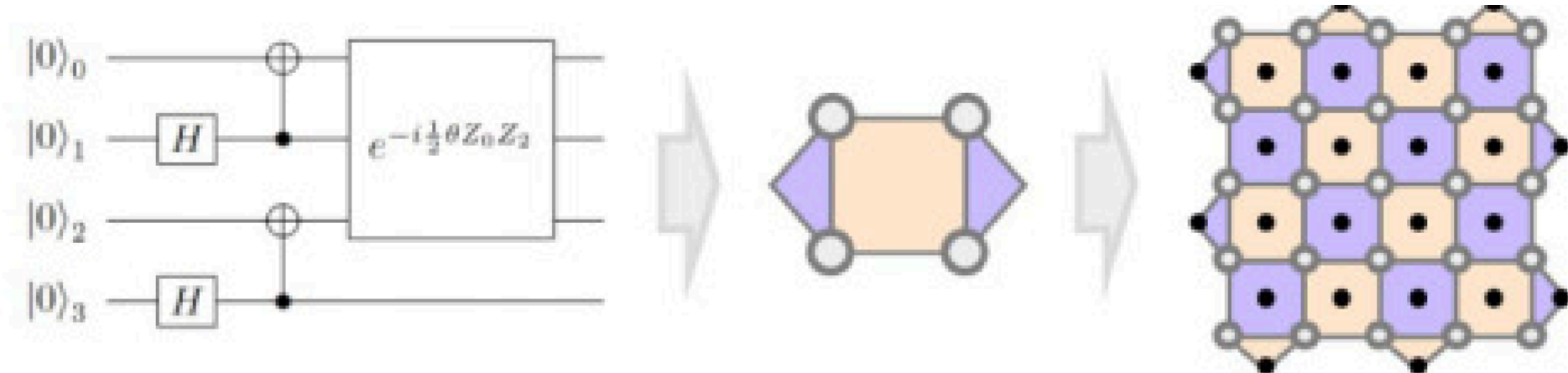
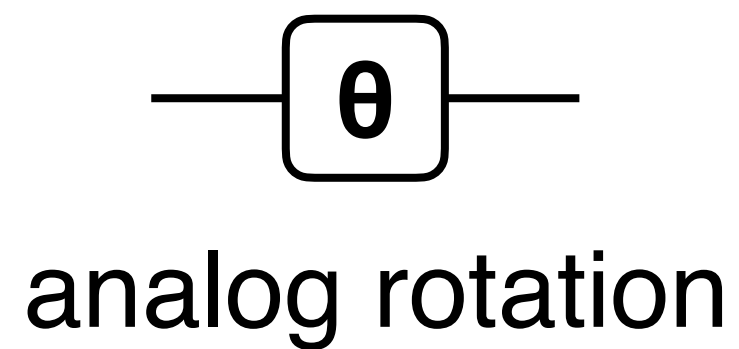

[[4,2,2]] code (error detection):  $p_\theta = O(p)$

## Ver. 2

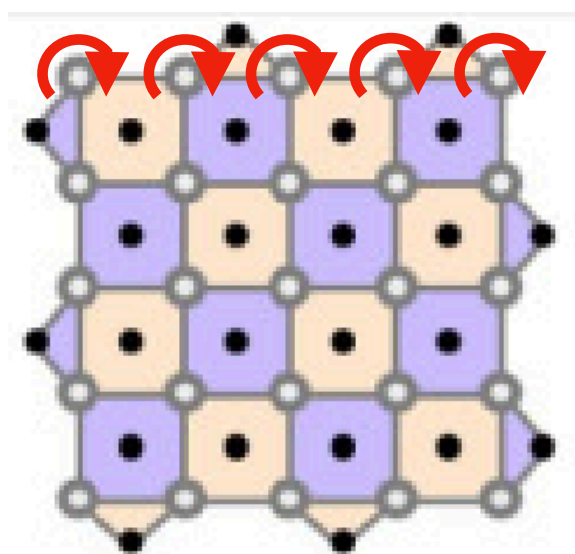
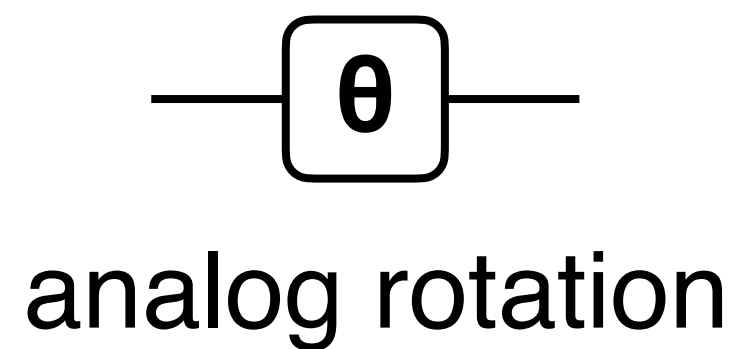

transversal analog rotation & postselection [Choi'23]

$$p_\theta = O(\theta p)$$

## Ver. 3 [NEW! arXiv:2603.22891]

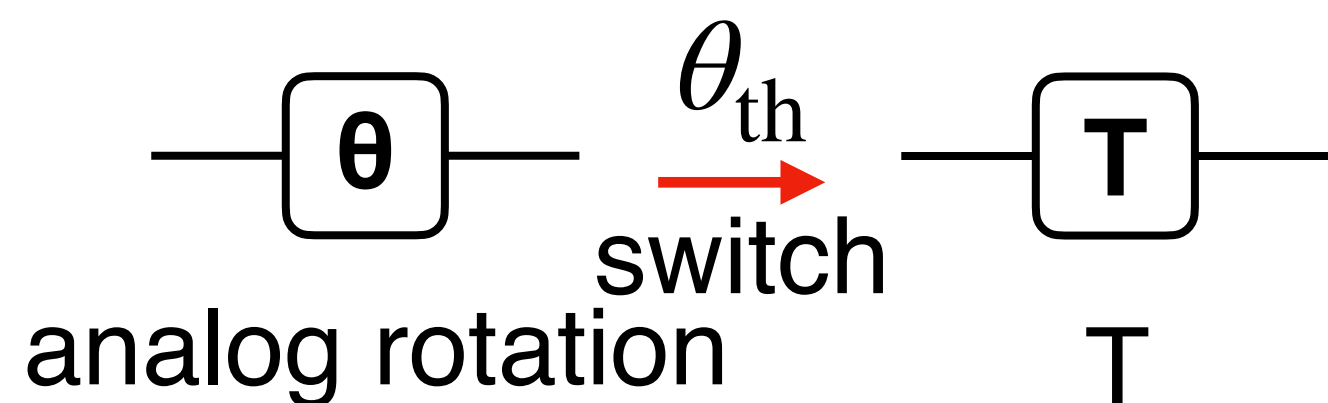

$$p_\theta \sim O(\theta^2 p)$$

$$\text{ex) } p \sim 10^{-4} \rightarrow p_\theta \sim 10^{-4}$$

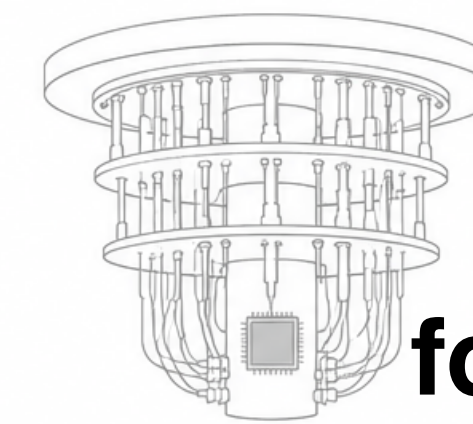

**better than NISQ**  
**for quantum advantage**

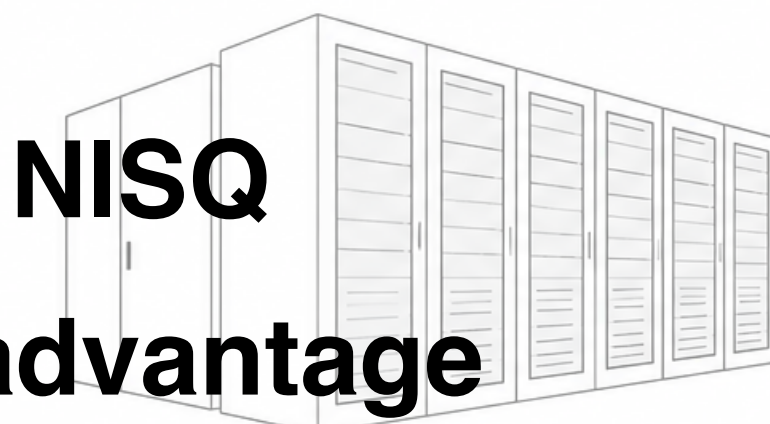

$$\text{ex) } \theta \sim 10^{-3}, p \sim 10^{-3} \rightarrow p_\theta \sim 10^{-6}$$

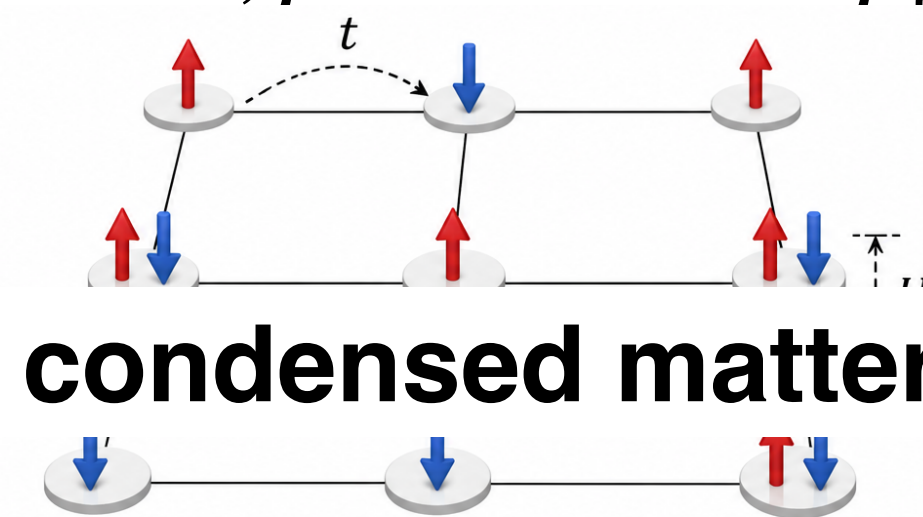

**useful for condensed matter physics**

$$\text{ex) } \theta \sim 10^{-3}, p \sim 10^{-3} \rightarrow p_\theta \sim 10^{-9}$$

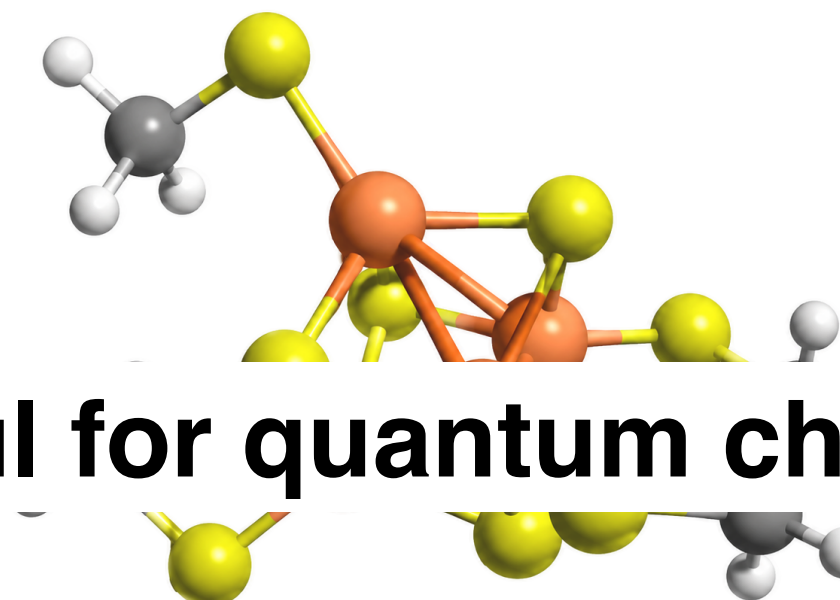

**useful for quantum chemistry**

# Conclusion

- Early FTQC (1k–100k qubits) is the realistic near-term regime for quantum advantage.
- Partially fault-tolerant architectures (STAR) to bridge NISQ and FTQC.
- STAR / Magic Mutation enables quantum simulation of practically relevant problems with  $\sim 10^5$  qubits (tens-fold reduction).
- Is the STAR architecture only effective for superconducting qubits? → Transversal STAR by QuEra (arXiv:2509.18294).
- Does this increase the complexity of compilation and optimization?
- Is it possible to establish a new proof of fault tolerance that does not rely on T-gate fault tolerance?

## Funding acknowledgement:

MEXT Q-LEAP Quantum AI flagship, JST COI-NEXT Quantum Software Research Hub  
JST Moonshot Goal6, JST CREST



Fujitsu Quantum Computing Joint  
Research Division at QIQB