

# Deep Learning in High Energy Physics

**Sergei Gleyzer**



**University of Alabama** **ML4SCI**

**PHENO 2026**

**May 12, 2026**

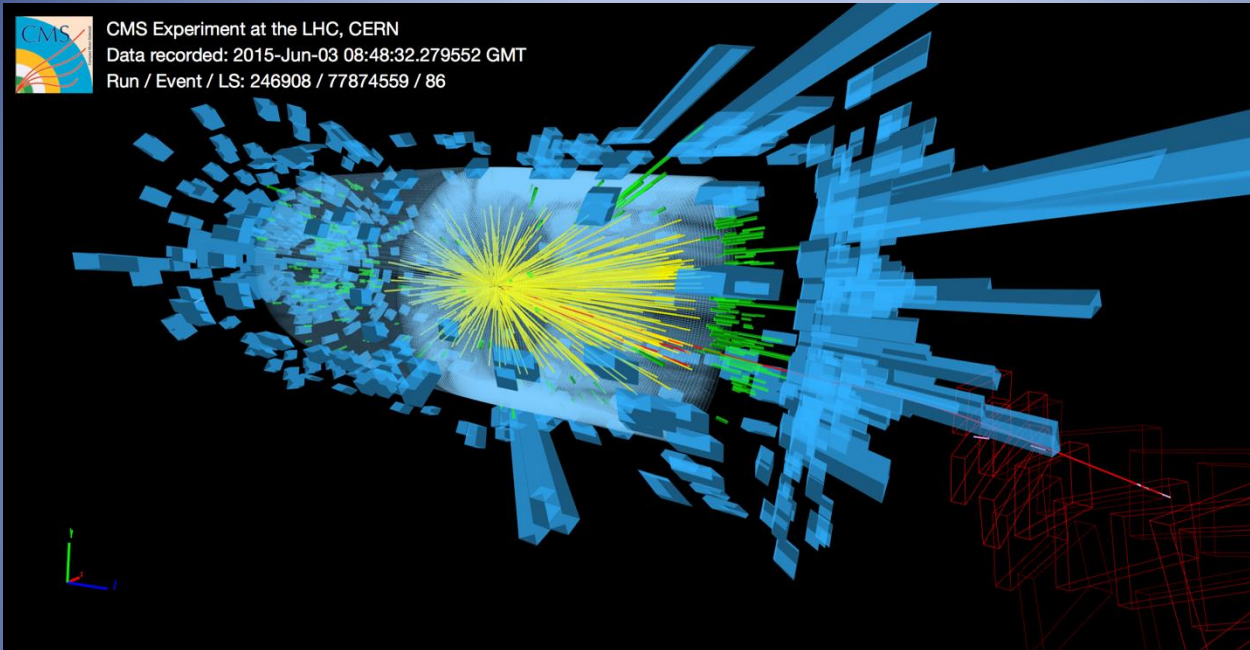

# ML/AI in Particle Physics

# What is Machine Learning

- *Study of algorithms that improve their performance  $P$  for a given task  $T$  with more experience  $E$*

Sample tasks: identifying faces, Higgs bosons

# High-Energy Physics Today

## Machine learning at the forefront of what we do:

- Physics object **identification**
- Event type **classification**
- Fast event **generation**
- Object properties **regression**
- Anomaly **detection**
- **Expanding rapidly**

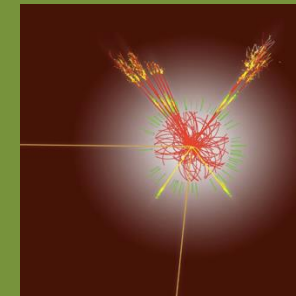
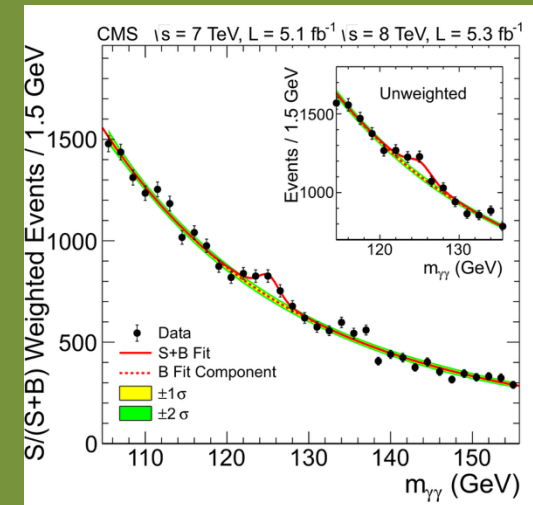
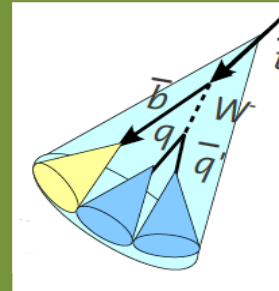

# Large Hadron Collider

Modern scientific wonder:

Operating since 2010

Expected to run for the next 15 years

Amazing success of an international collaboration of thousands of scientists from across the world



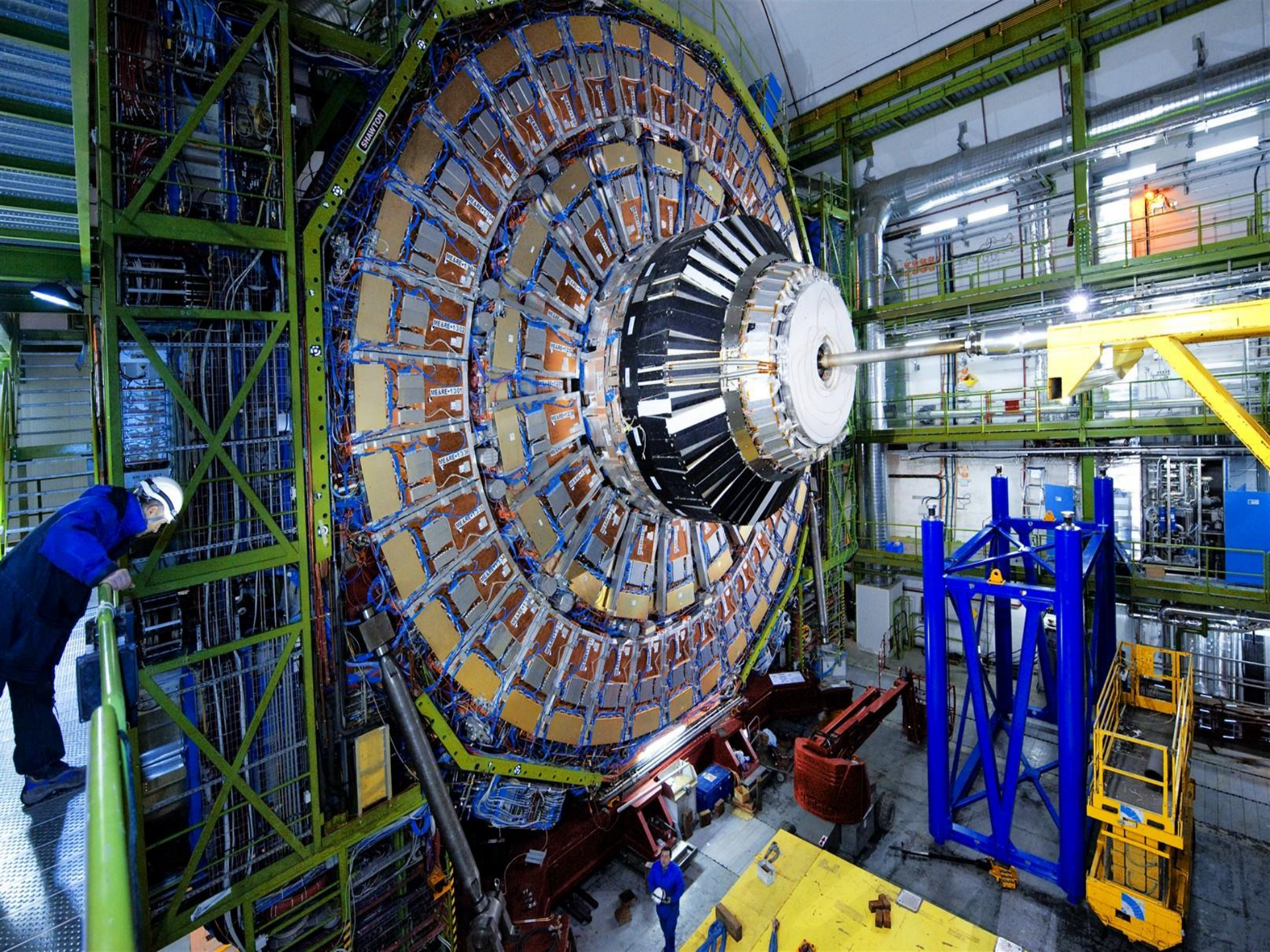

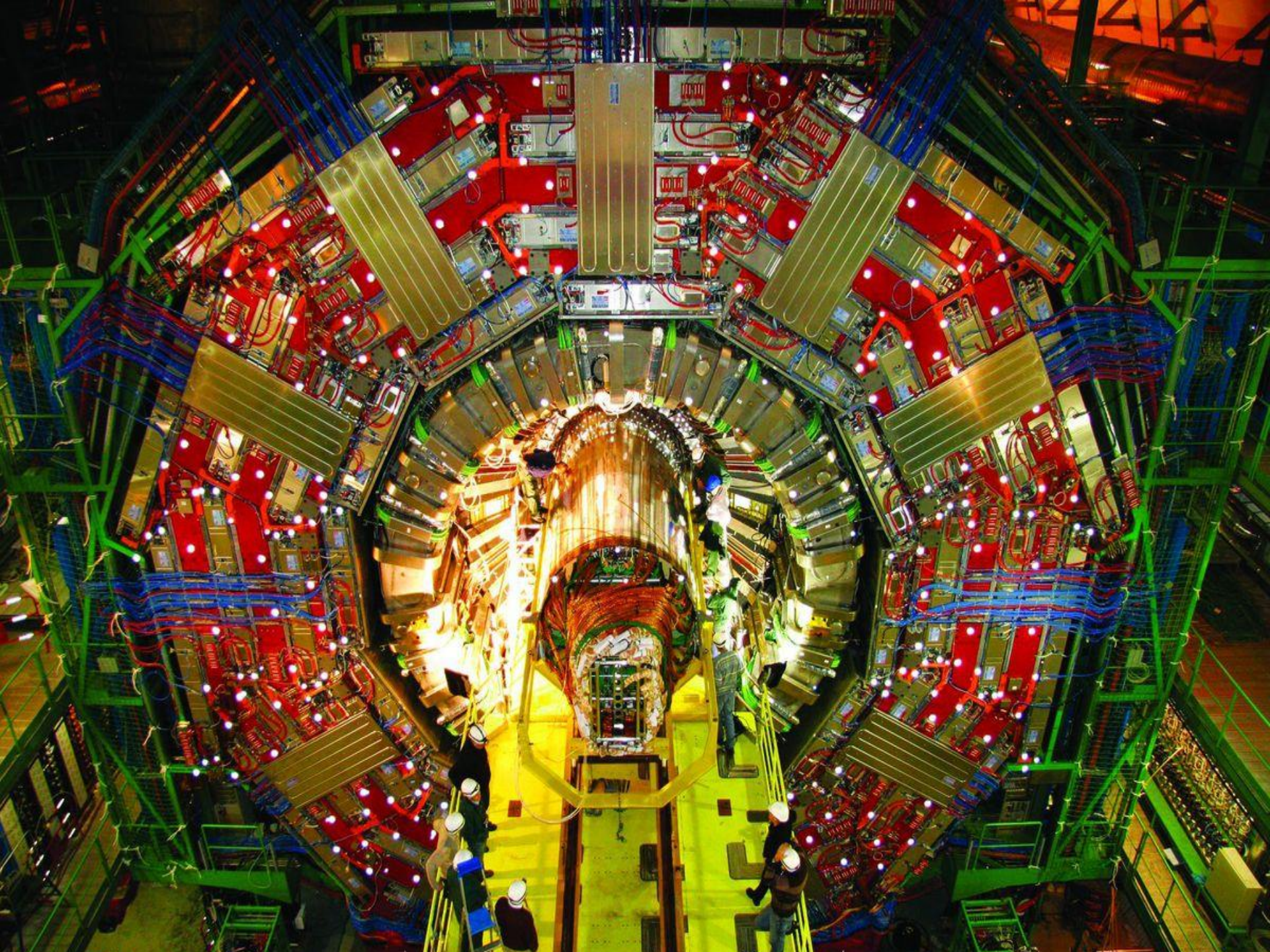

# Higgs Boson Discovery



# Higgs to di-photons

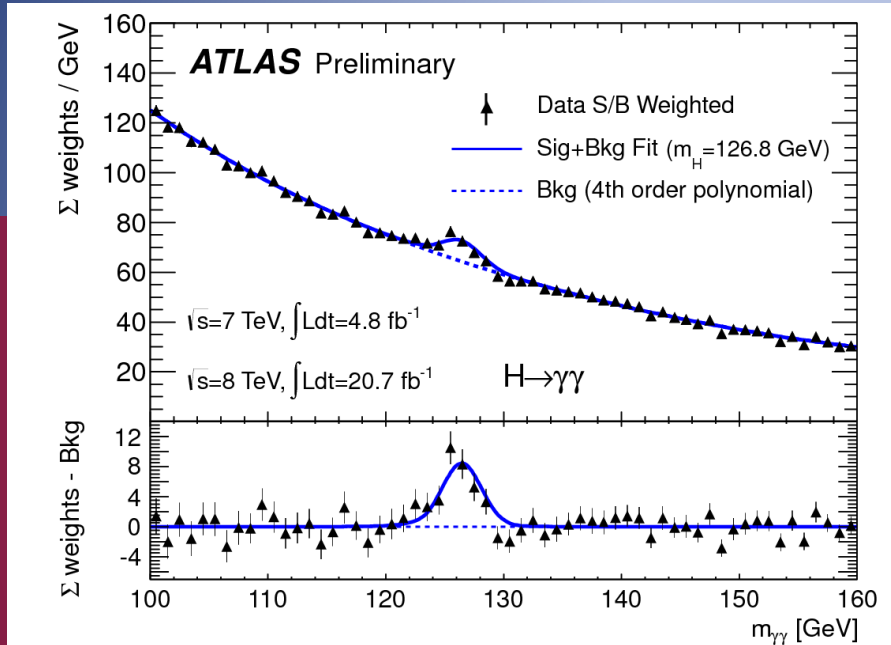

ATLAS

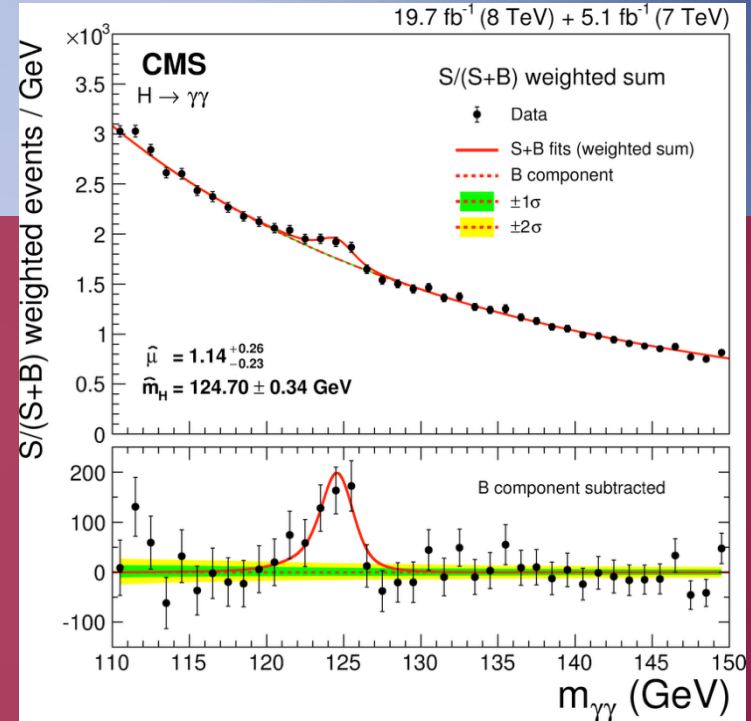

CMS

# Higgs Discovery



# In Higgs Discovery

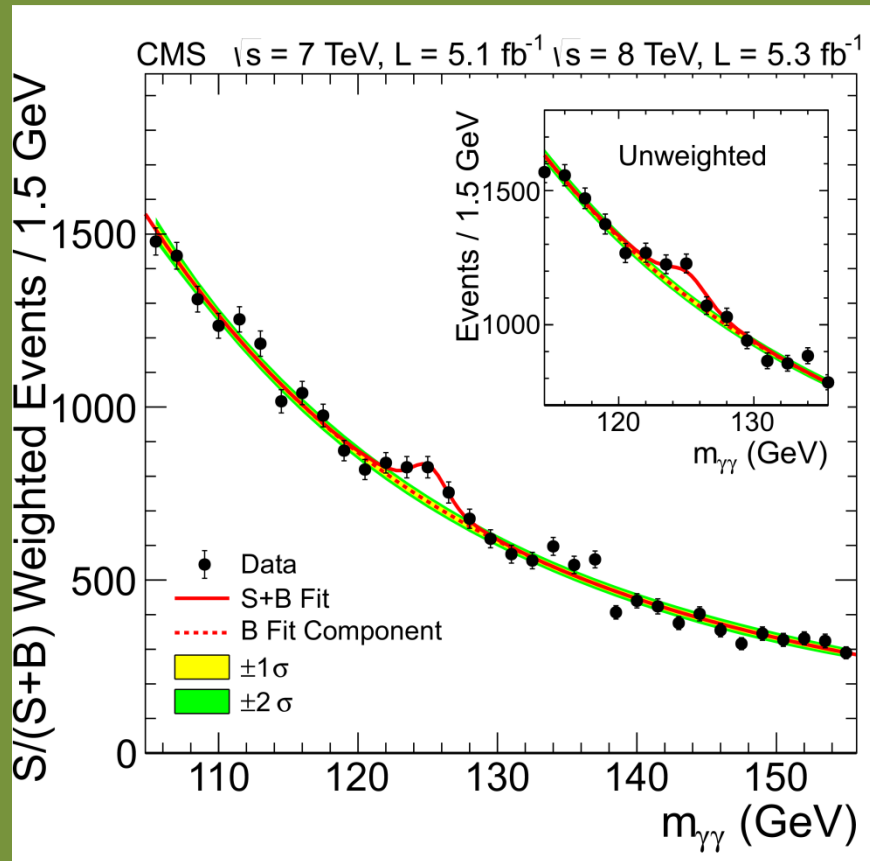

- Identification of particles
- Identification of interactions
- Energy regression
- Event selection

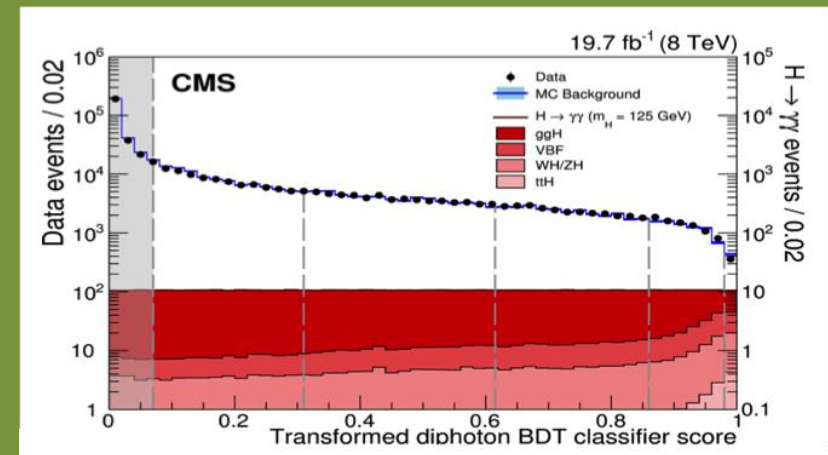

Improvement in analysis from all four areas

# Relevant areas

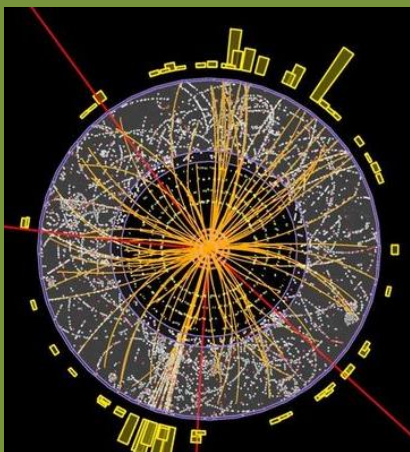

Tracking

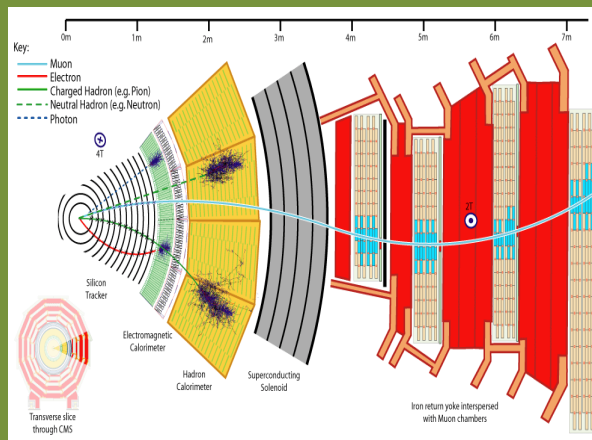

Object Identification

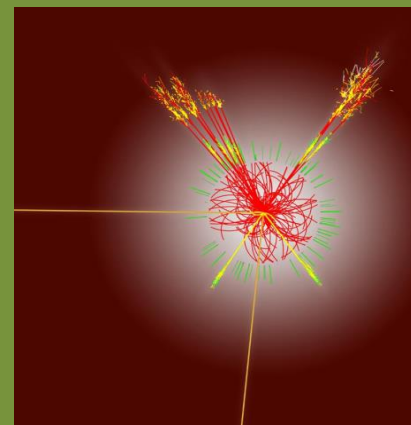

Fast Simulation

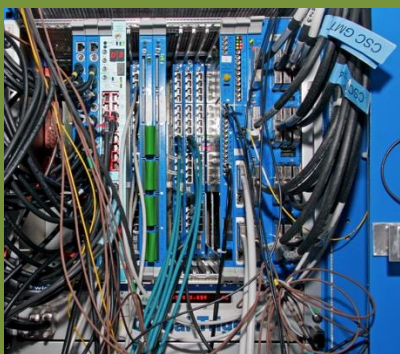

Trigger

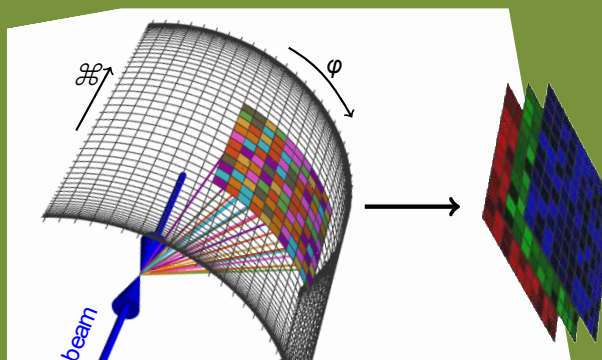

Imaging/Graph Techniques

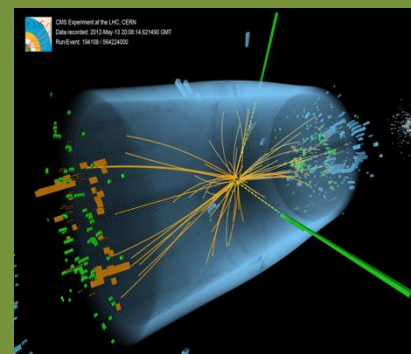

Event Level ID

# CMS Detector and Particle ID

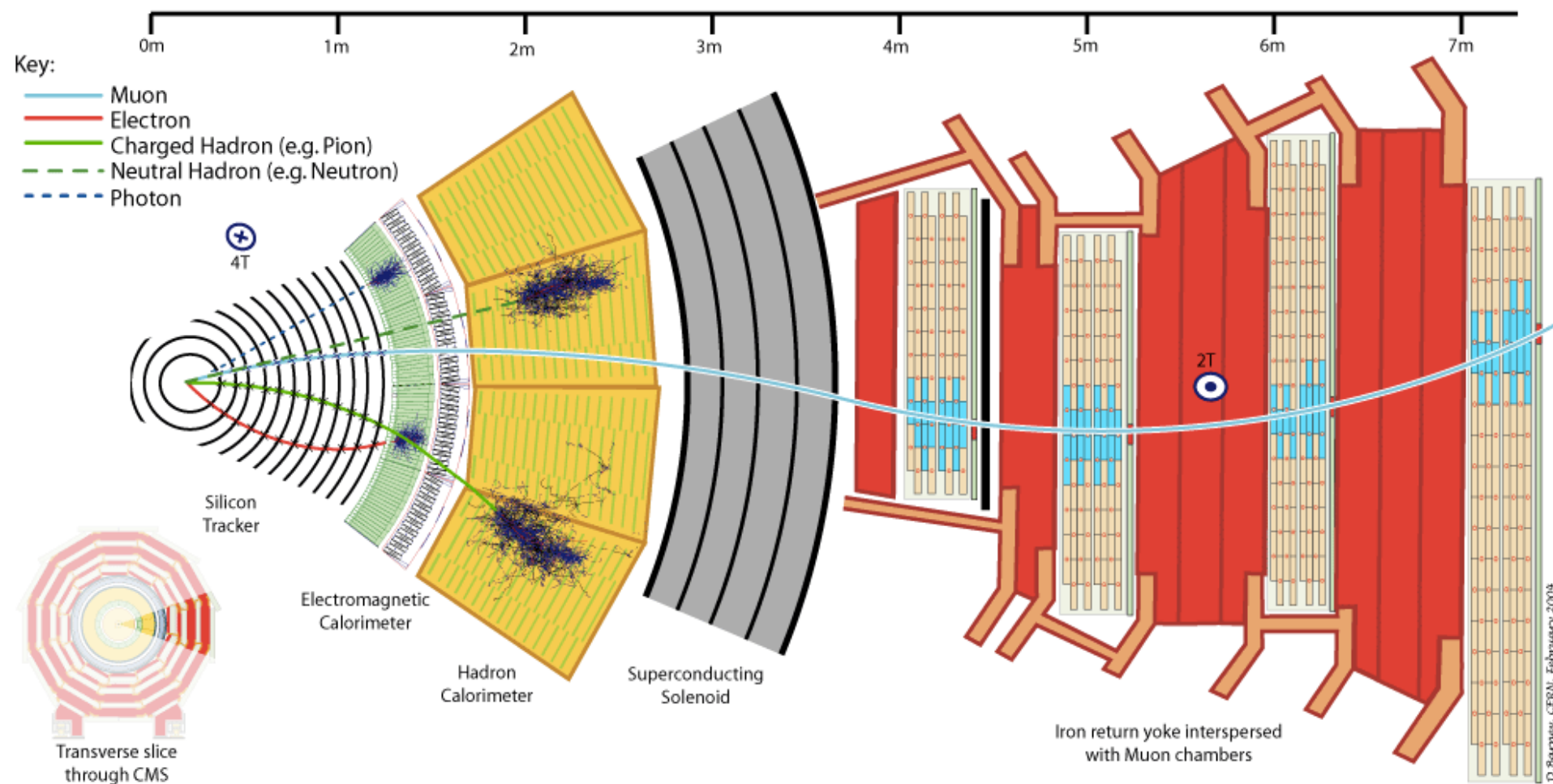

# Key Question

Can we **fully exploit** the detectors?

low-level data + modern deep learning

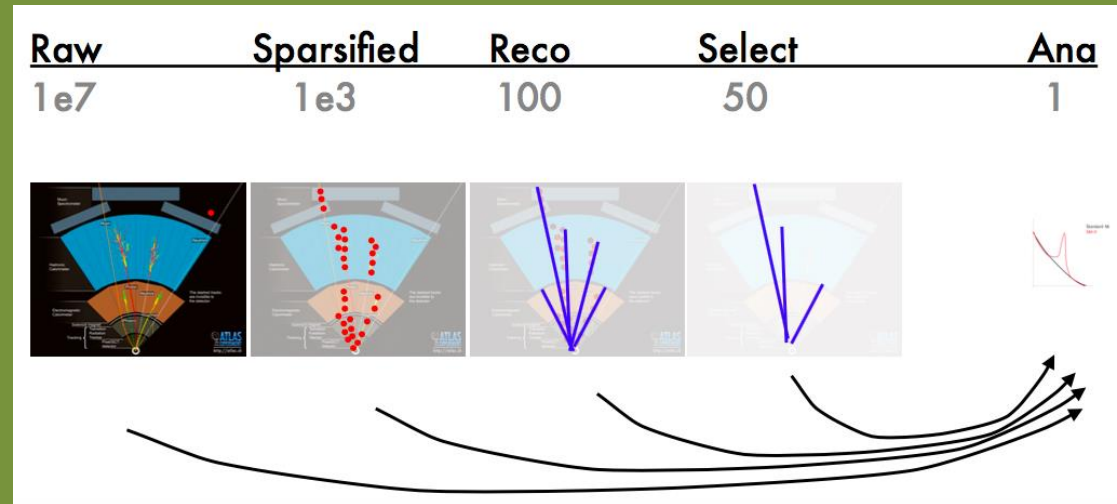
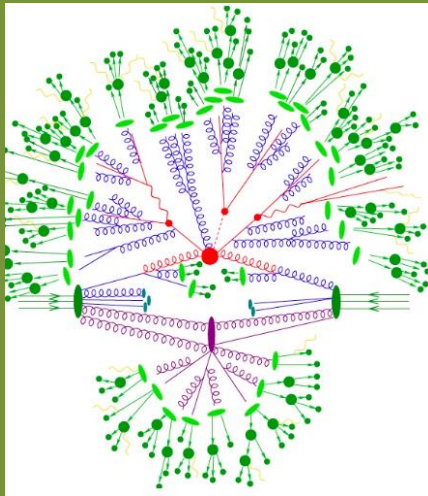

Andrews et al.  
Comp.Soft.Big.Sci. 4 (2020) 6

End-end learning



# End-to-End Deep Learning

By-passing traditional reconstruction with deep neural networks

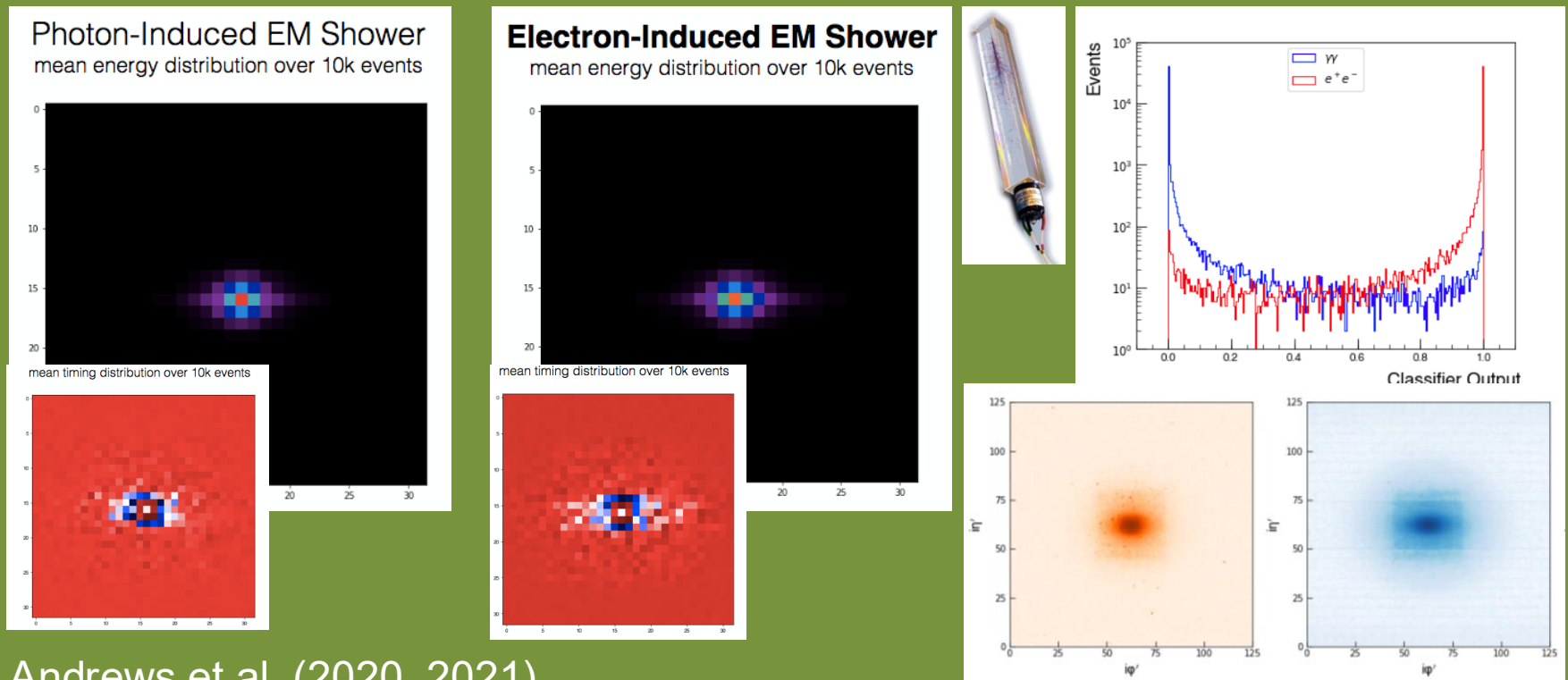

Andrews et al. (2020, 2021)

# End-to-End Jets

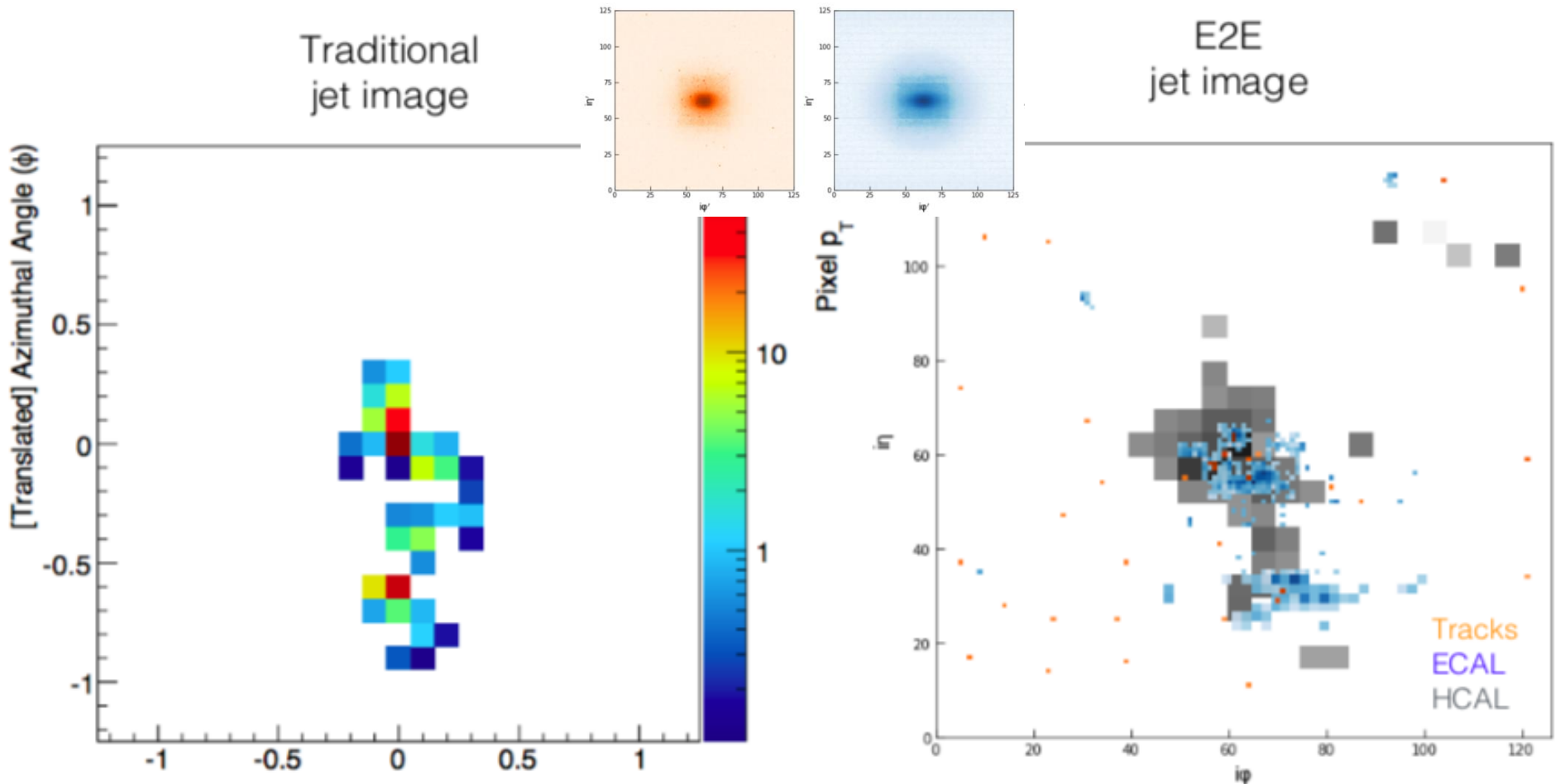

Andrews et al. (2020)

# End-to-End Top Quark Pair

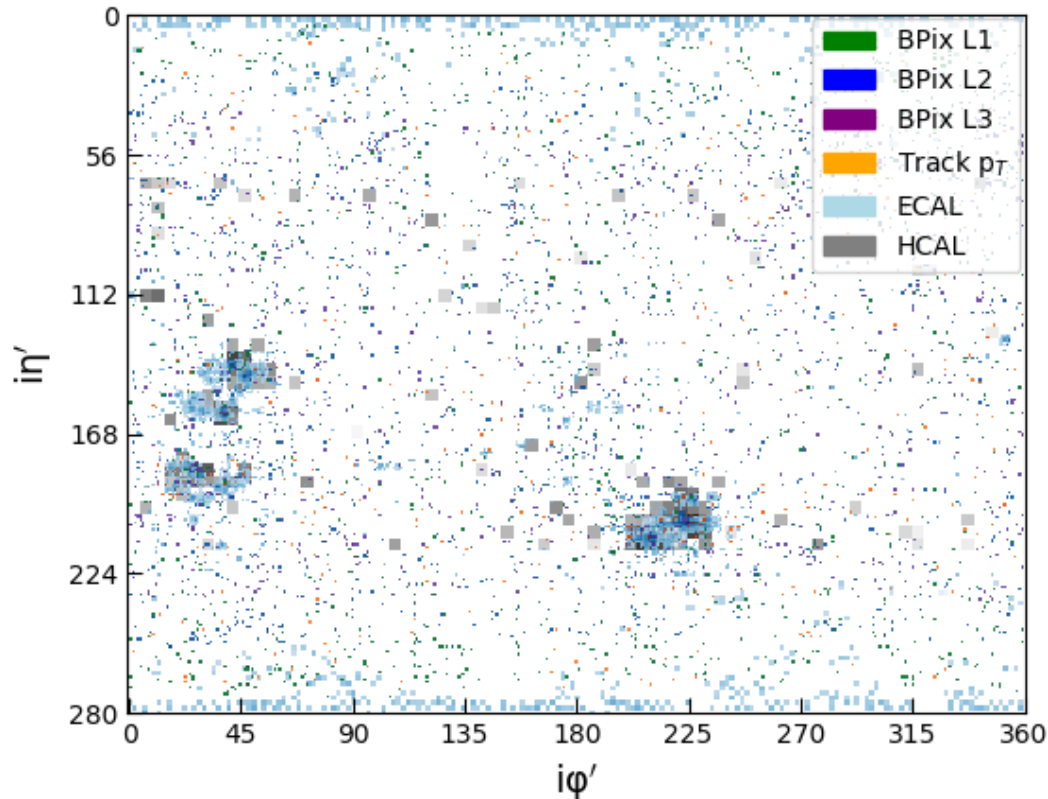

Block	Layer Type	Extra Parameters
Input Node	Conv 2D	filter size 7, stride 2, 16 channels
	Global Pool 2D	$2 \times 2$ pool size
Resblock 1	Conv 2D	filter size 3, stride 1, 16 channels
	Conv 2D	filter size 3, stride 1, 16 channels
Resblock 2	Conv 2D	filter size 3, stride 2, 32 channels
	Conv 2D	filter size 3, stride 1, 32 channels
Resblock 3	Conv 2D	filter size 3, stride 1, 32 channels
	Conv 2D	filter size 3, stride 1, 32 channels
Output Node	Max Pooling 2D	global pool size
	Dense	size $32 \times 2$
	Activation	Sigmoid

Layer Combinations	ROC-AUC
BPIX1-3	$0.947 \pm 0.002$
BPIX1-3 + Track $p_T$	$0.965 \pm 0.002$
BPIX1-3 + ECAL + HCAL (no reconstructed variables)	$0.975 \pm 0.002$
BPIX1-3 + Track $p_T$ + $d0$ + $dZ$	$0.977 \pm 0.002$
BPIX1-3 + Track $p_T$ + $d0$ + $dZ$ + ECAL + HCAL (full image)	$0.9824 \pm 0.0013$

Scalability Test

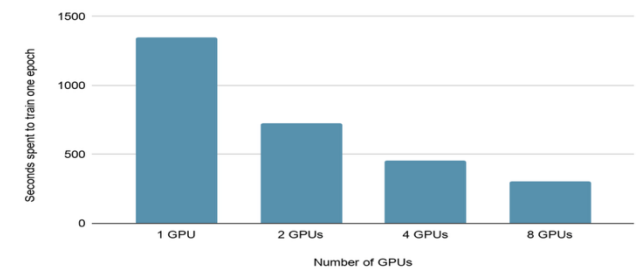

Andrews et al. (2021)

# H $\rightarrow$ 4 $\gamma$ rare decay

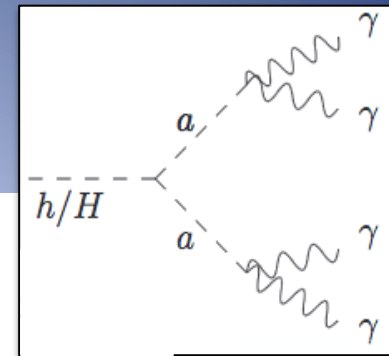

New windows of opportunity

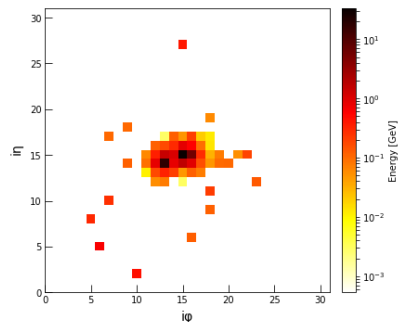

**a = 1 GeV**

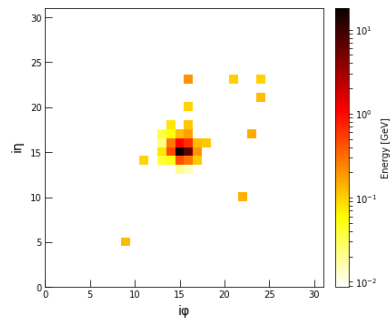

**200 MeV**

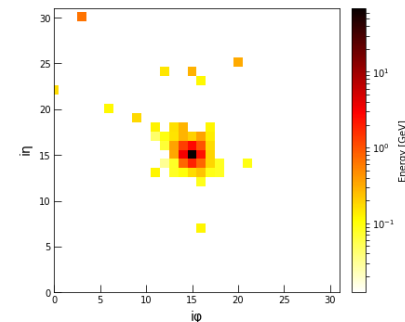

**100 MeV**

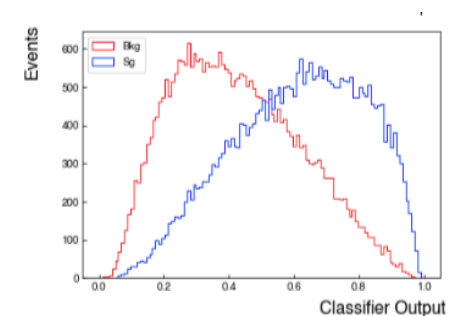
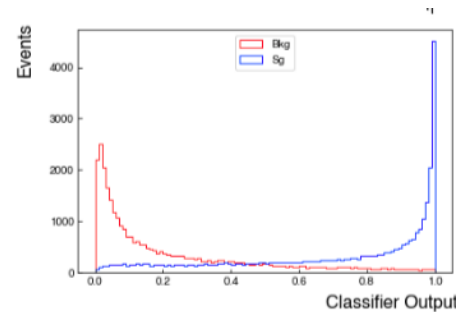
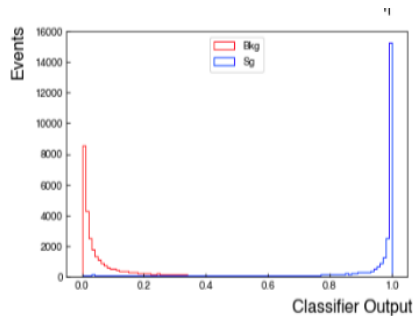

In areas previously too difficult to explore

**CMS (2023)**

# H $\rightarrow$ 4 $\gamma$ rare decay

New windows of opportunity

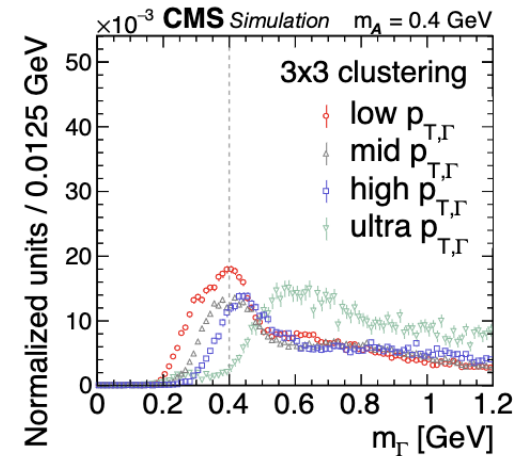
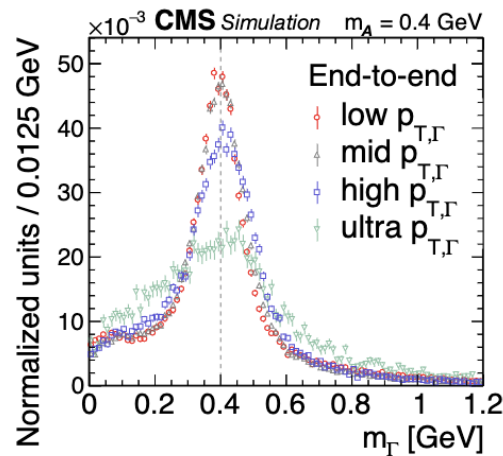
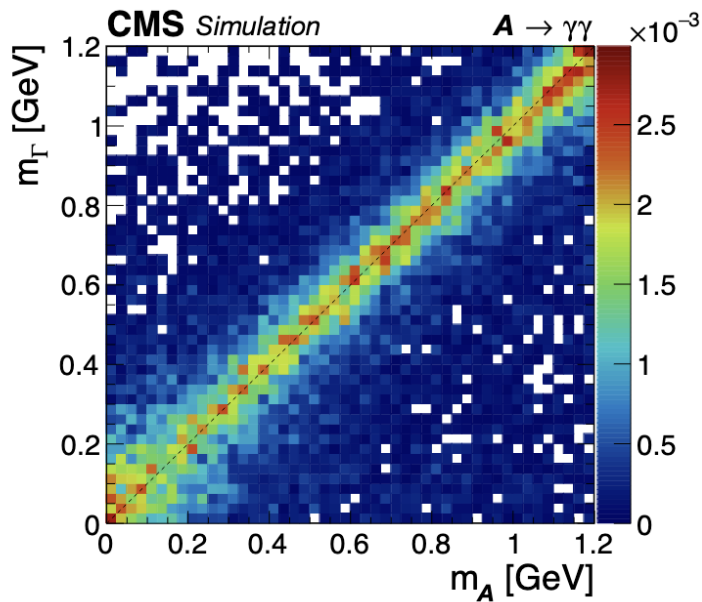

**CMS Collaboration (2023)**

# Delay Line Detectors

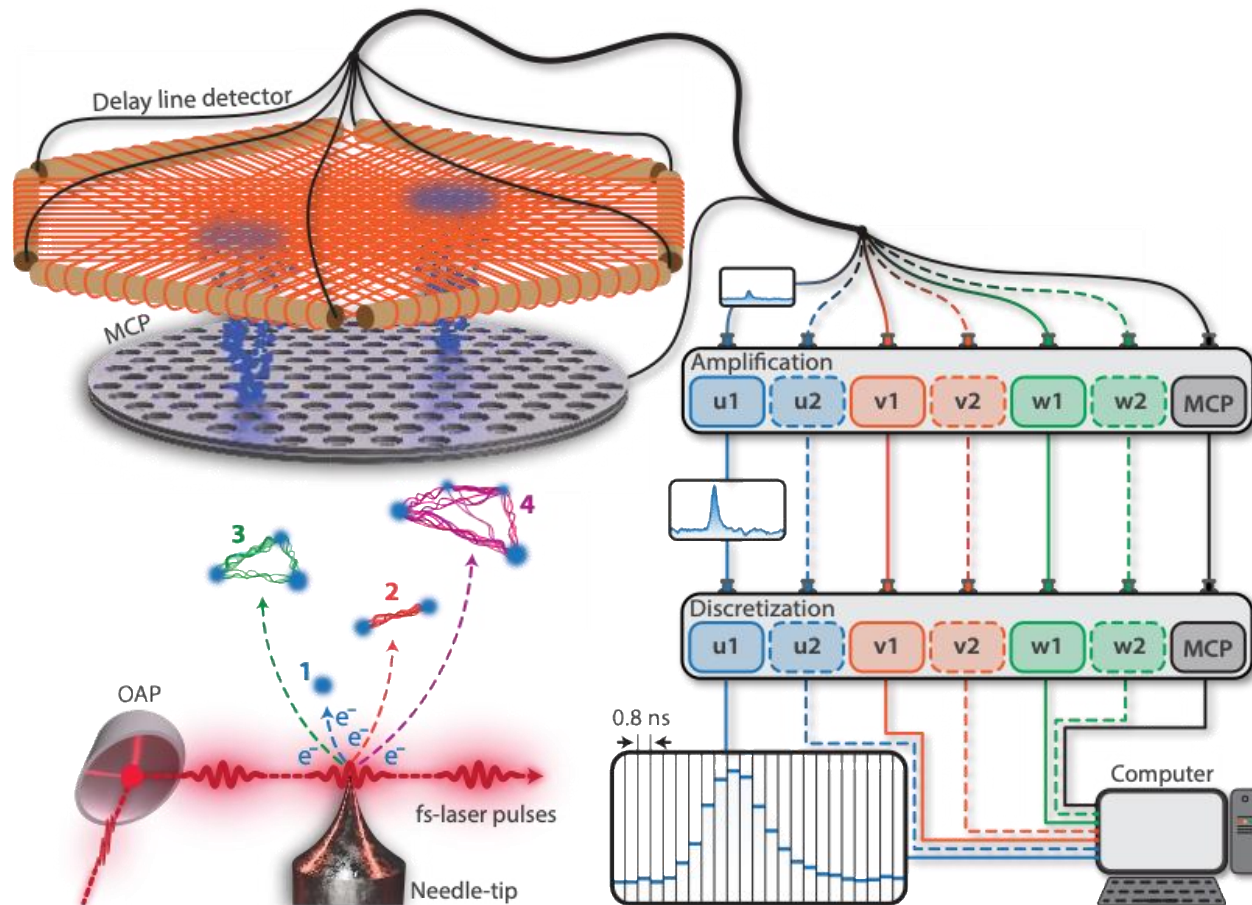

M. Knipfer et al. (2023)

# Delay Line Detectors

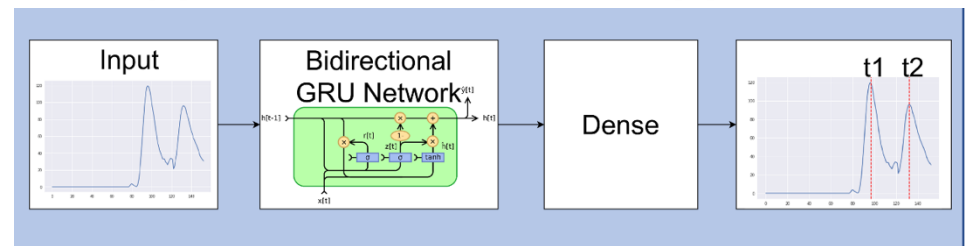
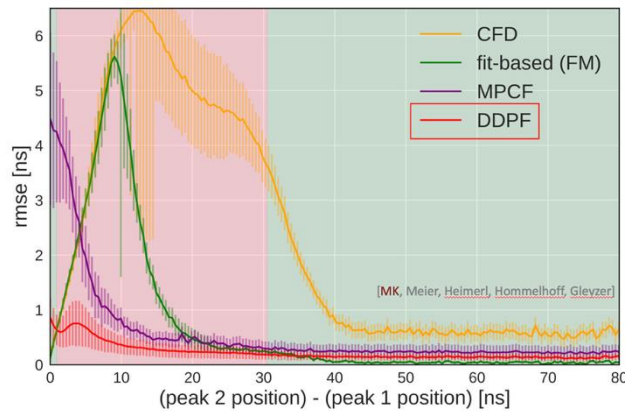
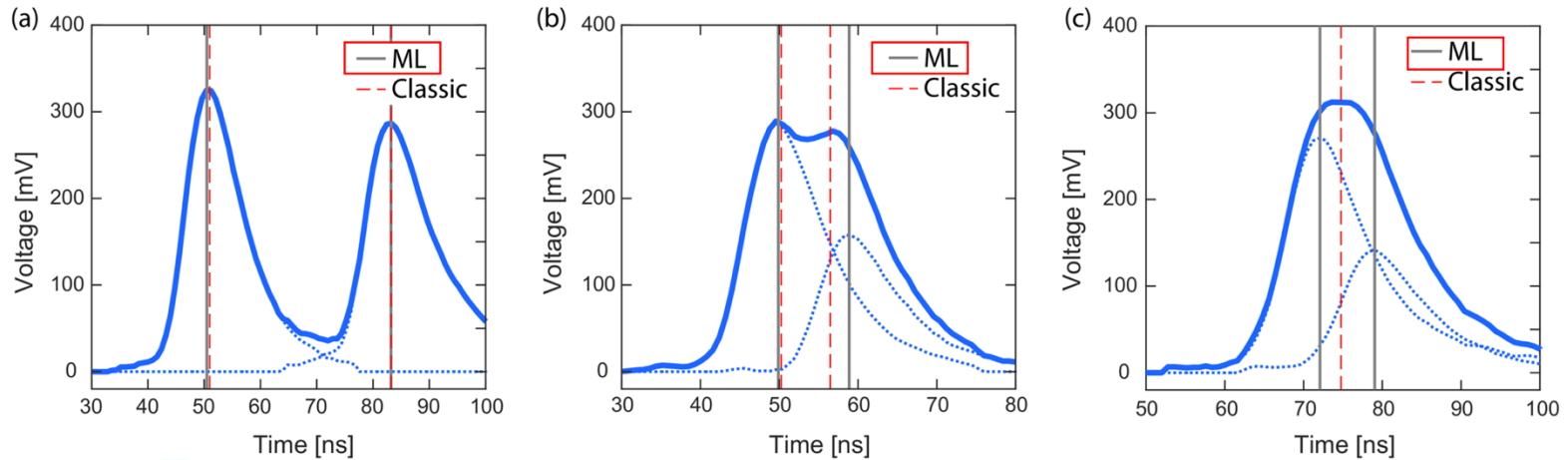

**Spatial** → **Temporal**

**M. Knipfer et al. (2023)**

# Delay Line Detectors

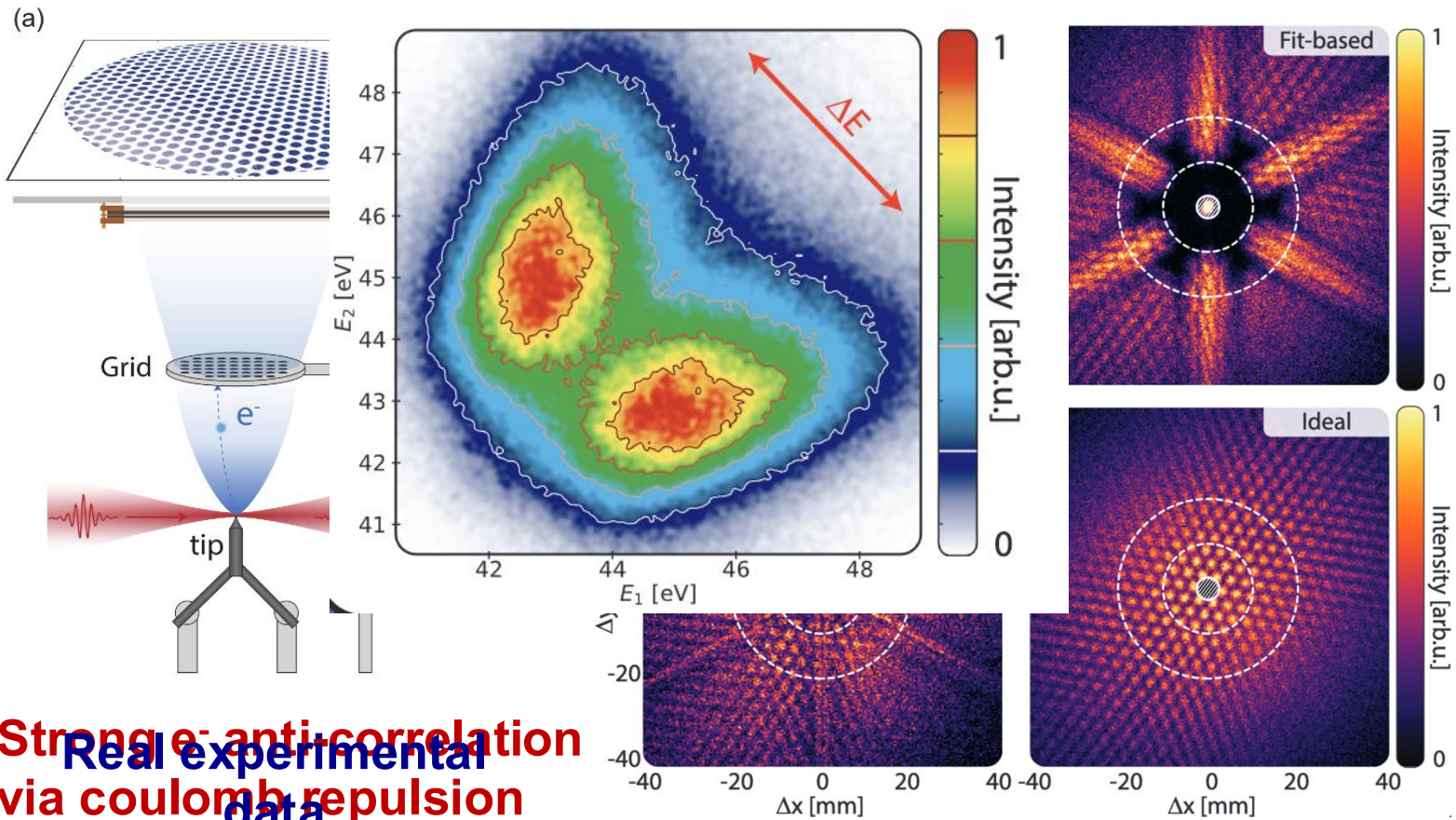

Strong  $e^-$  anti-correlation  
via coulomb repulsion  
in the dead region

Real experimental data

# Feature Extraction

Background Rejection vs. Signal Efficiency

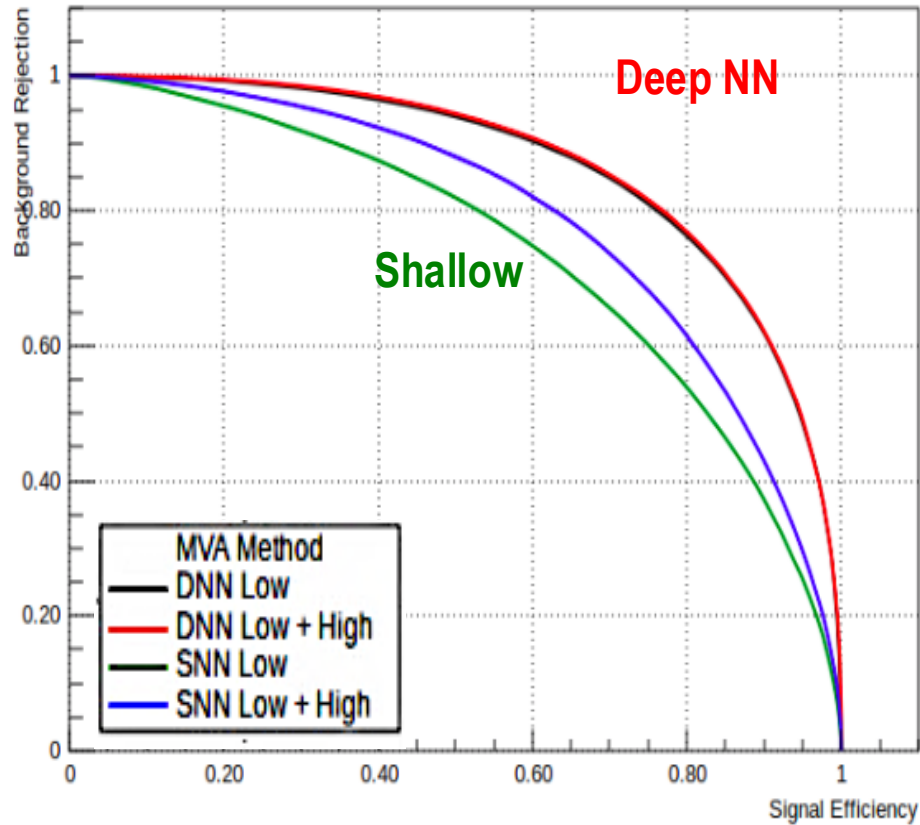

## Higgs Classification

# Upcoming Challenges

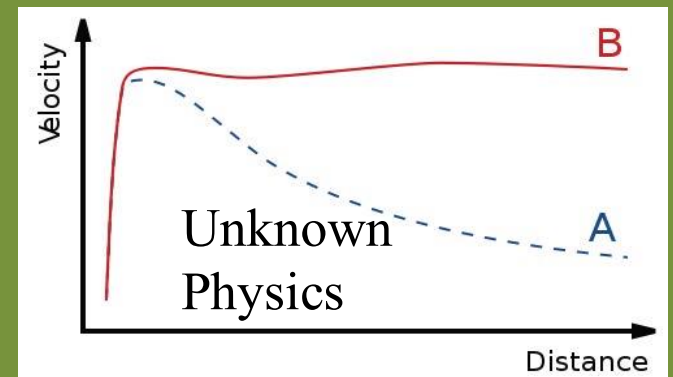
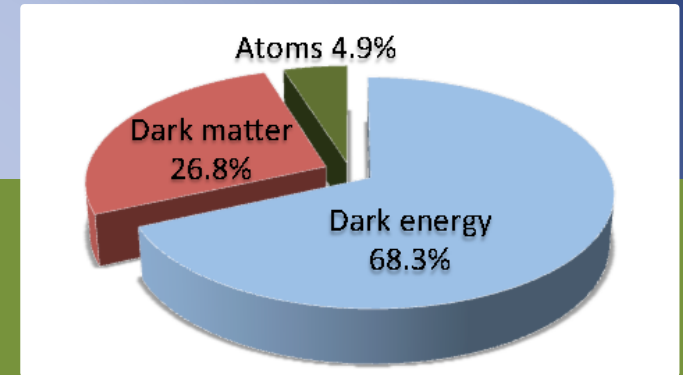
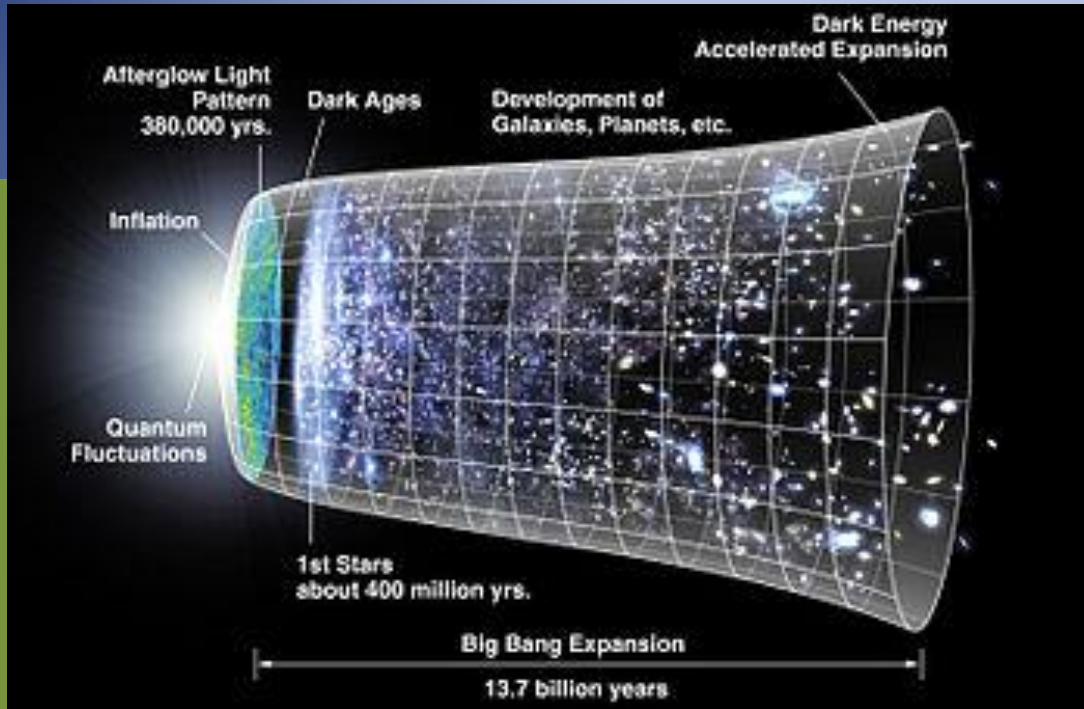

## Data size:

- LHC **15,000,000 Tb** 2010 - 2035
- Resources not up as fast as data volumes



# Pile-Up Collisions

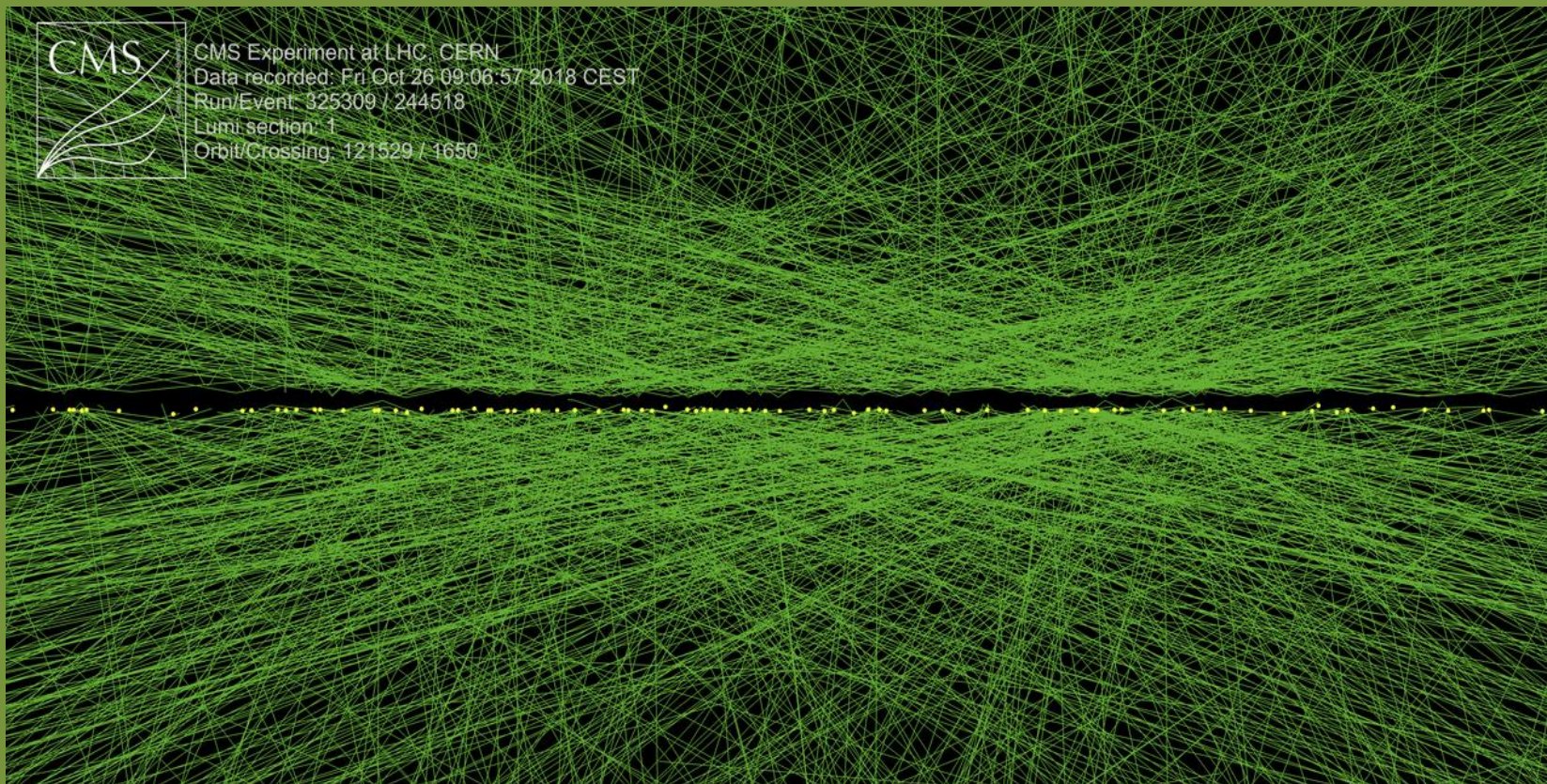

# Going Beyond Classification

# Generative Models

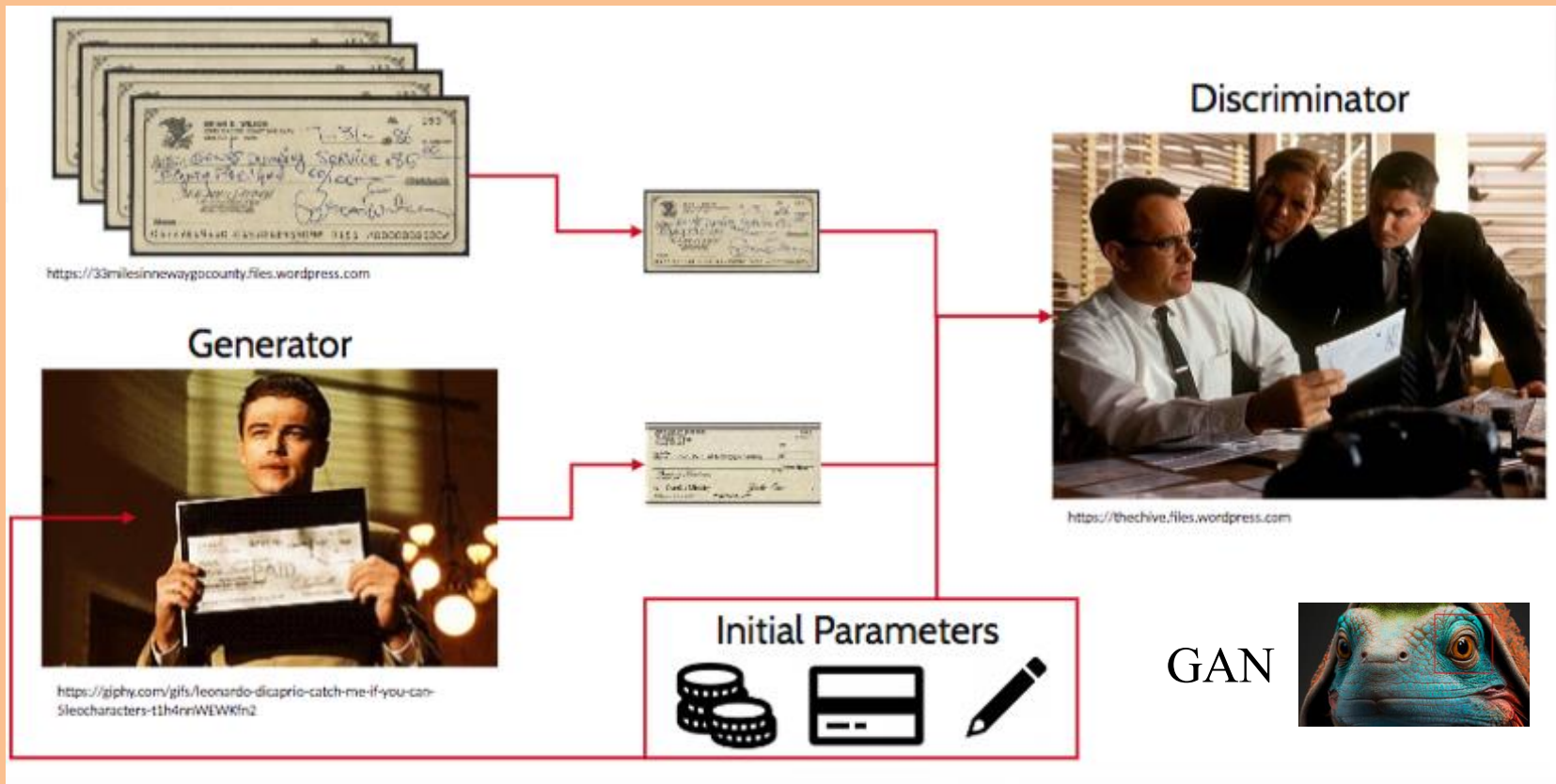

# Conditional GANs

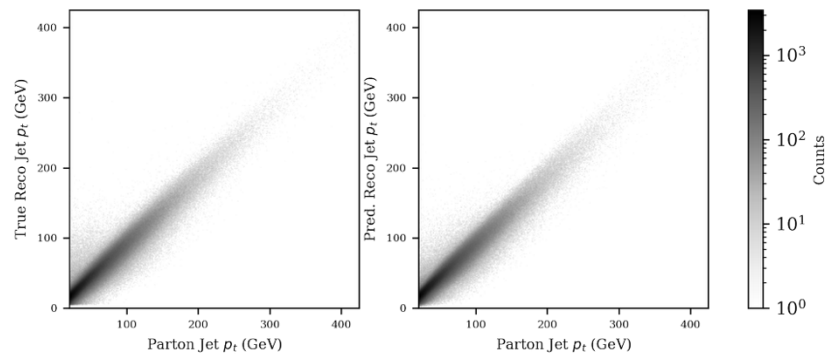
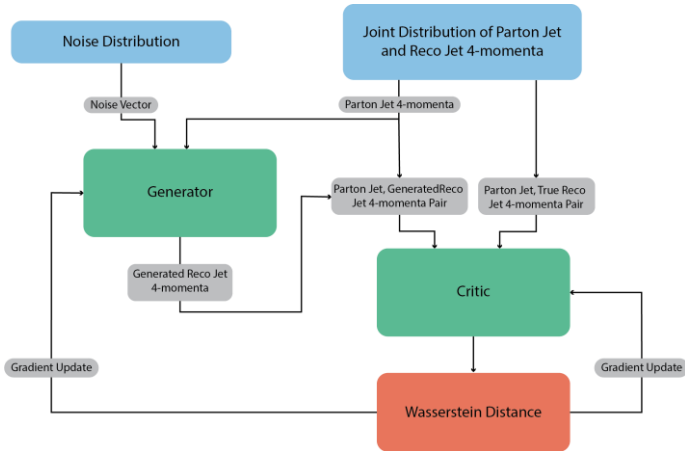
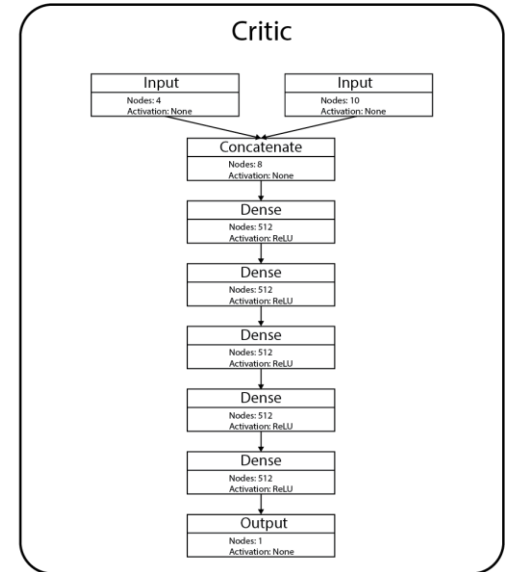
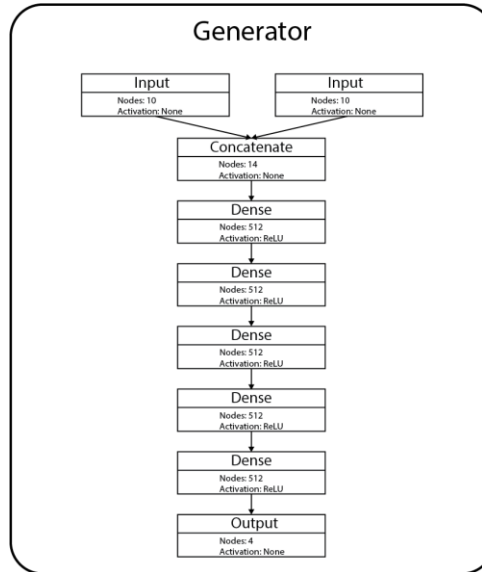
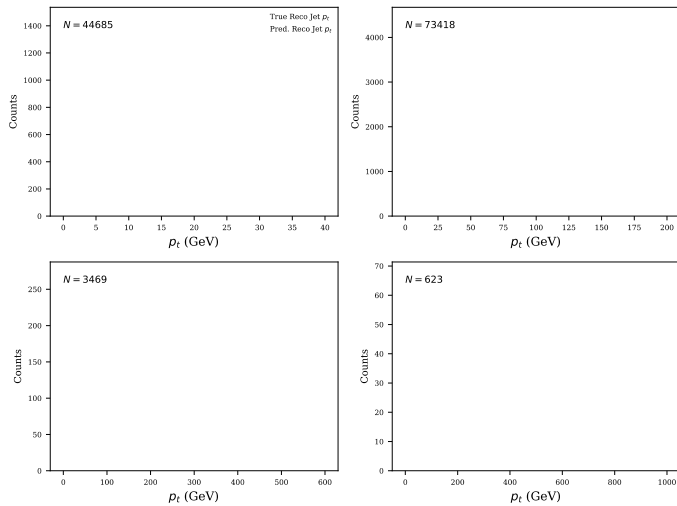

# Graph Neural Networks

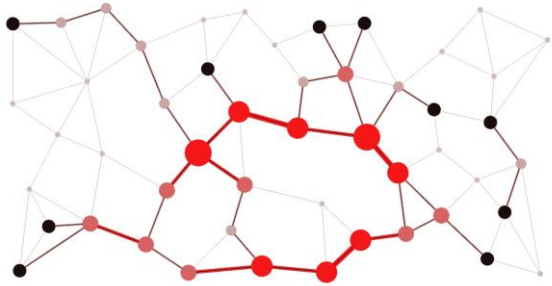

In

Reconstruction

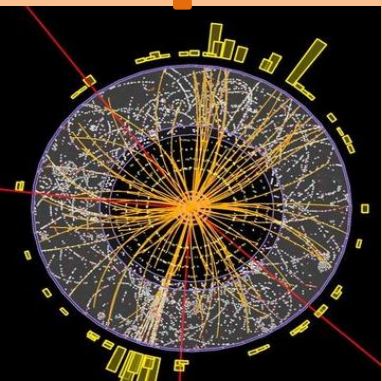
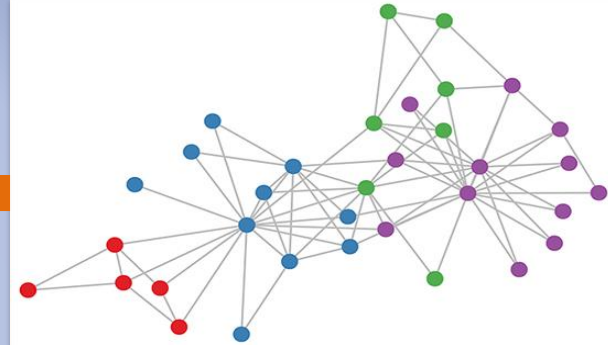

Trigger

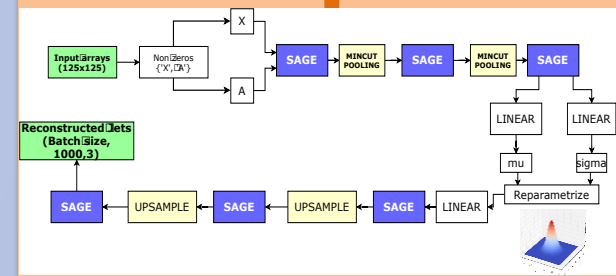
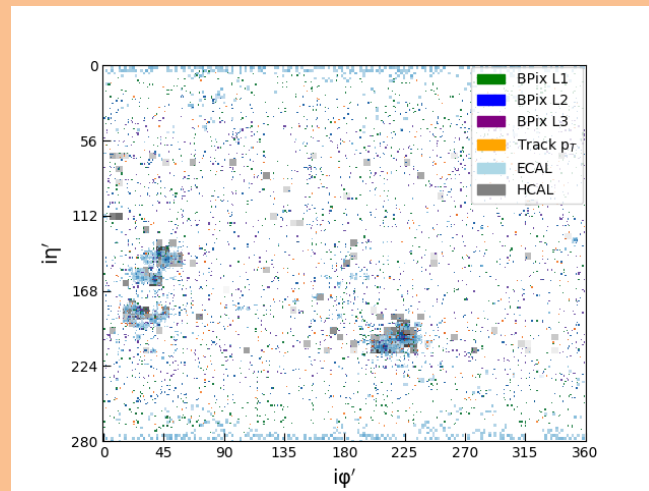

Fast  
Simulation

# Graph VAE for Fast Simulation

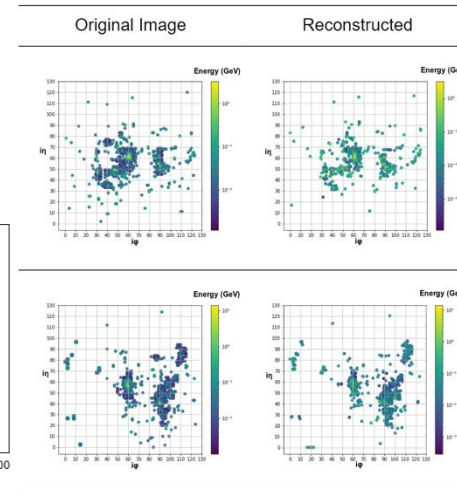
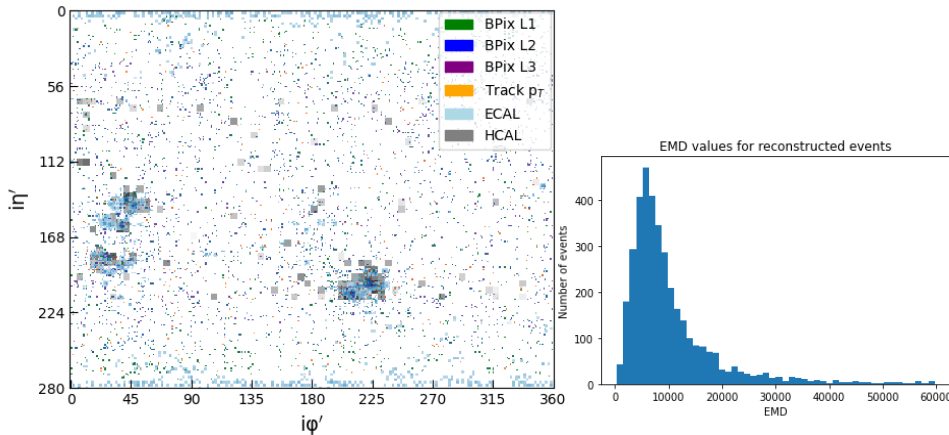
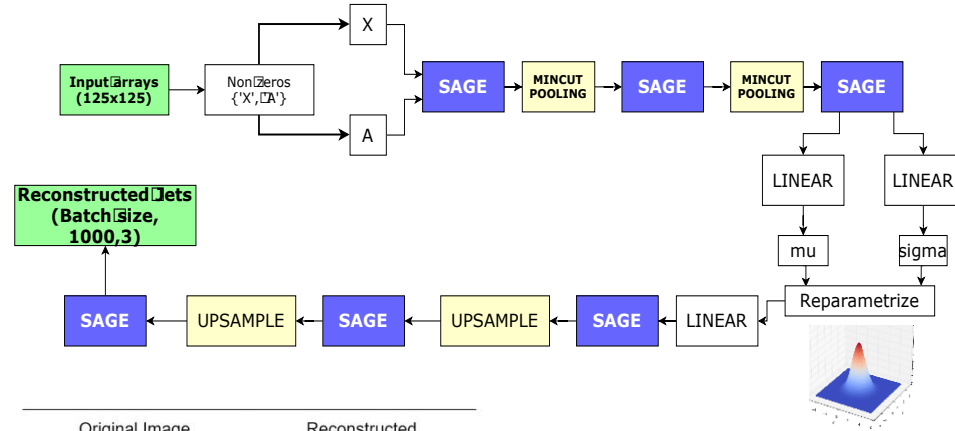
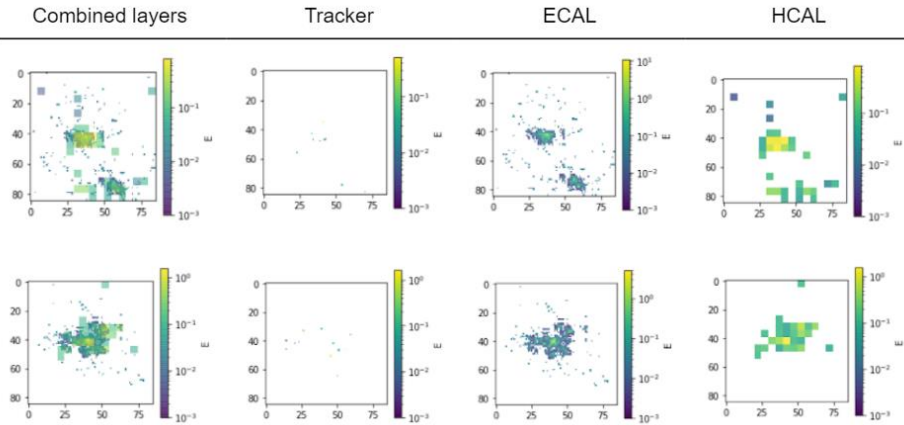

Time comparison between our Graph model and Monte Carlo

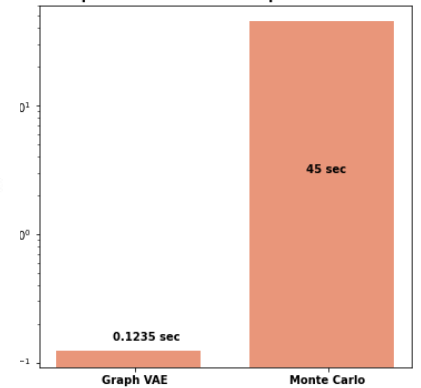

# Anomaly Detection (DQM)

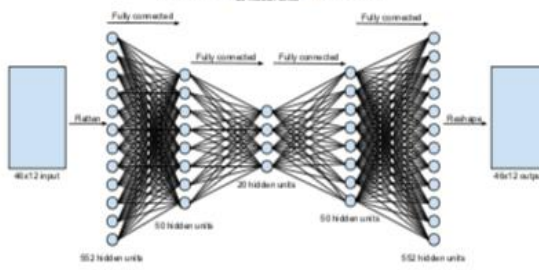
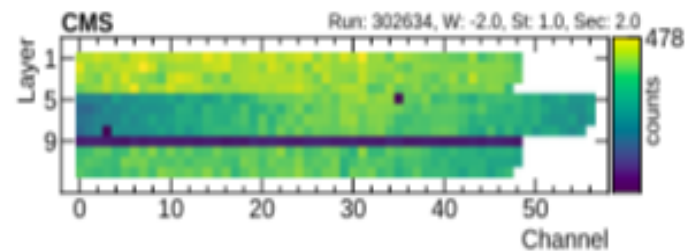
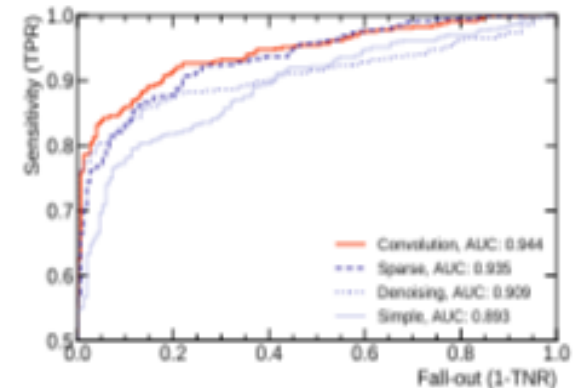
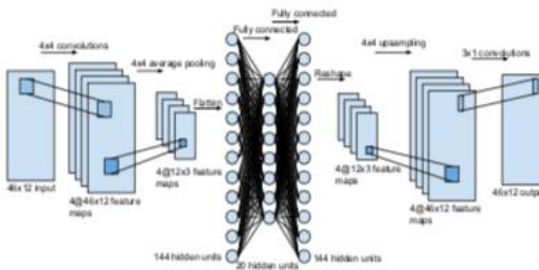
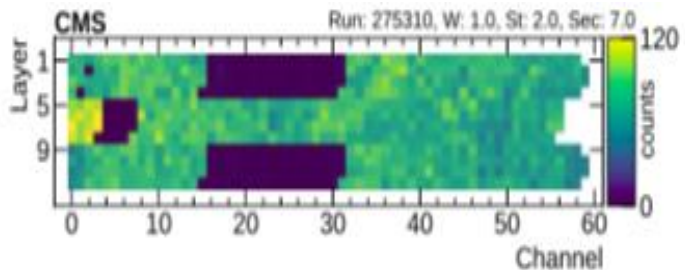
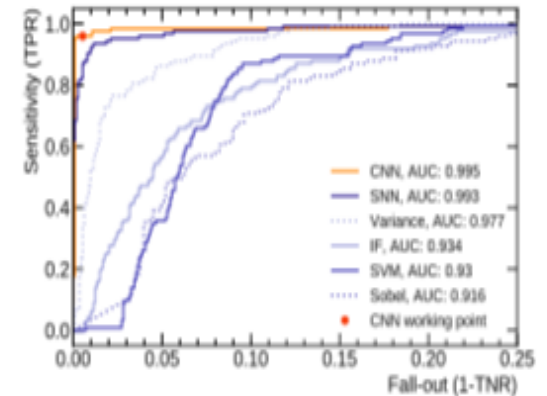
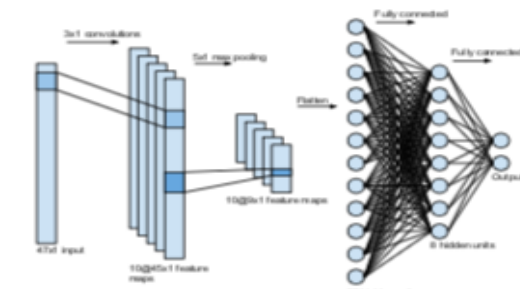
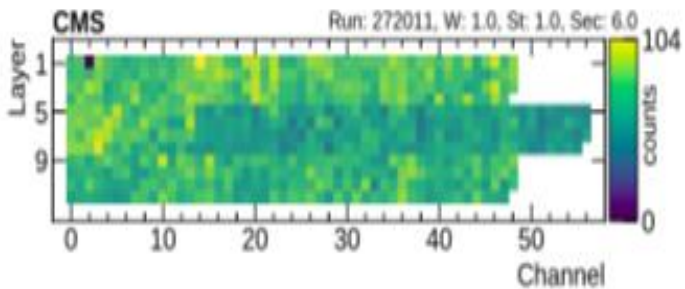

# Continual Learning (DQM)

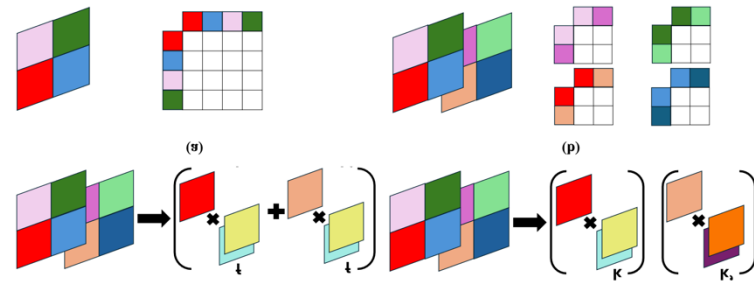
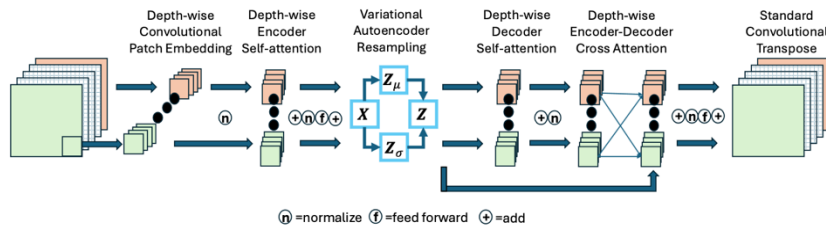
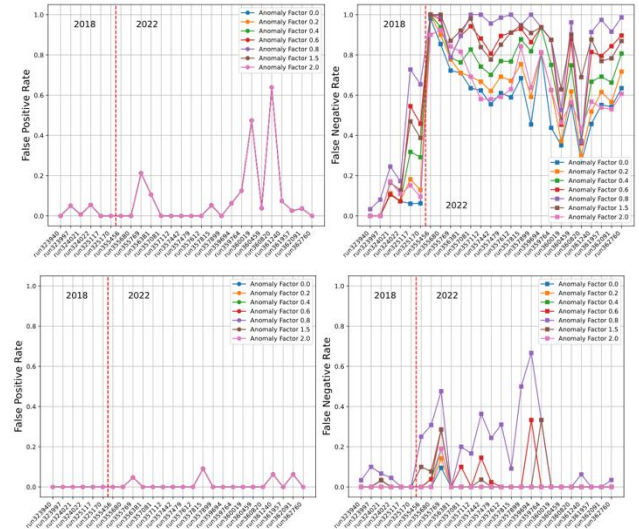
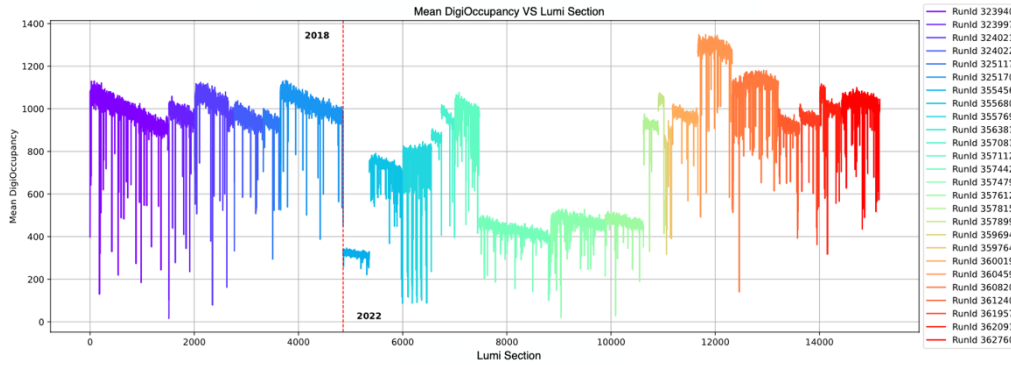

Julson et al. (2023)

# CMS Trigger System

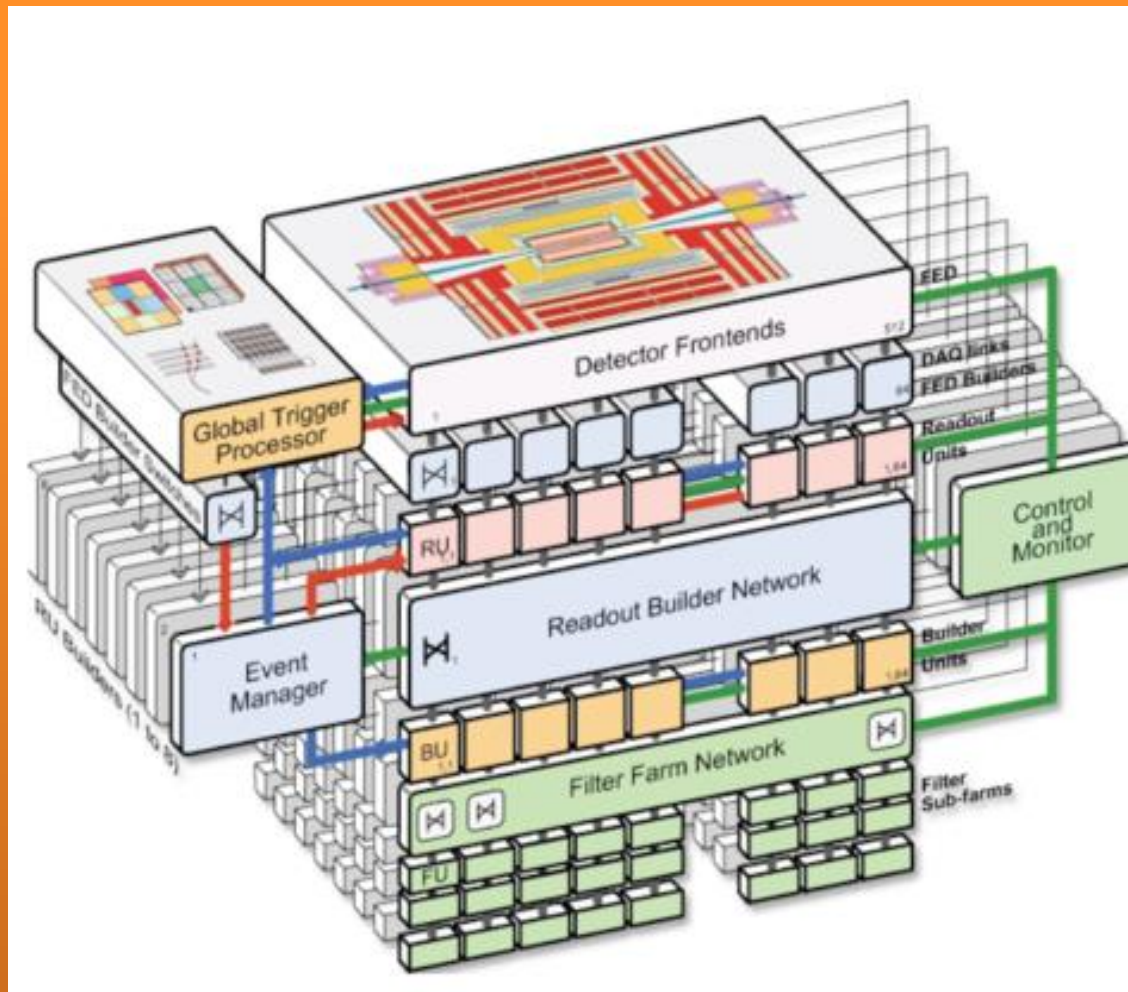

## Trigger Rate

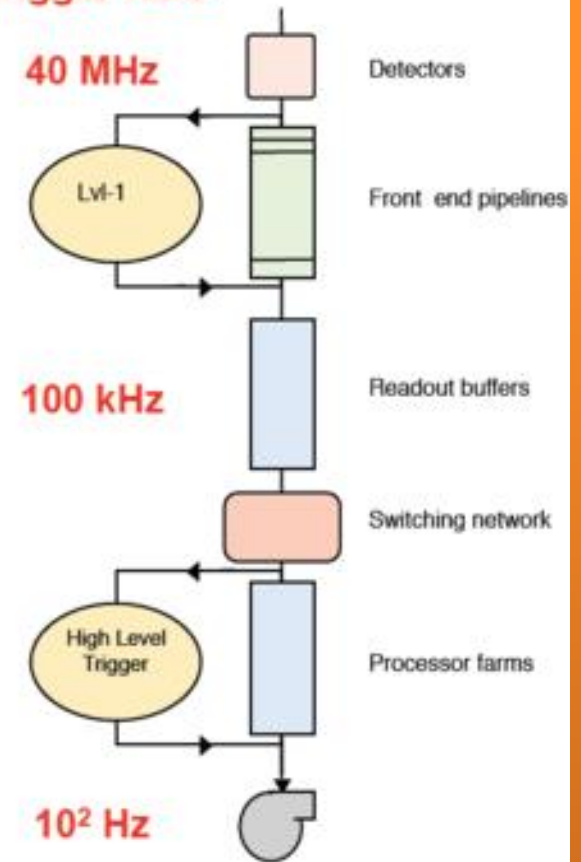

# Machine Learning Trigger

## ML at Level-1 Trigger

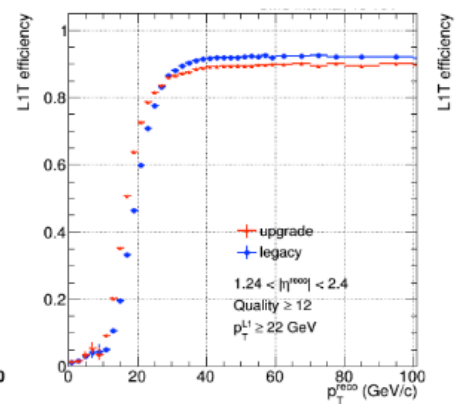
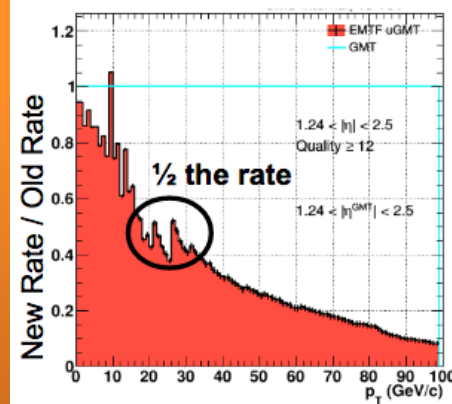
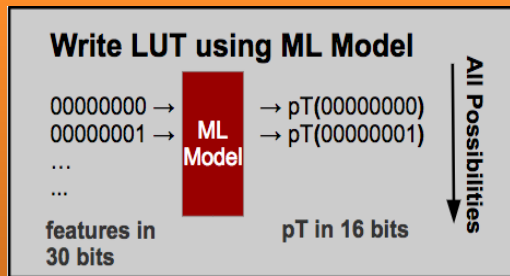

## FPGAs and Deep Learning

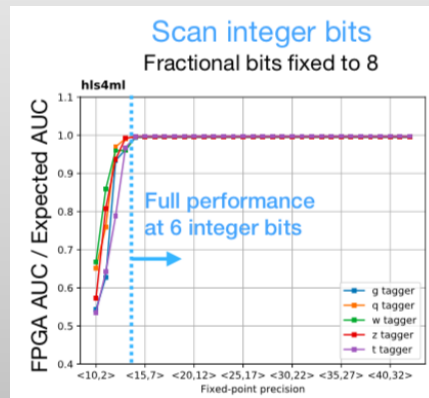
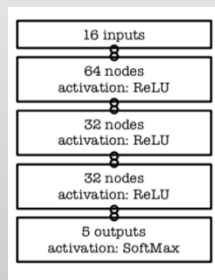
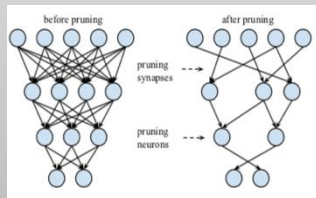
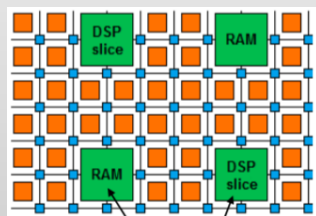

## Auto-Encoders

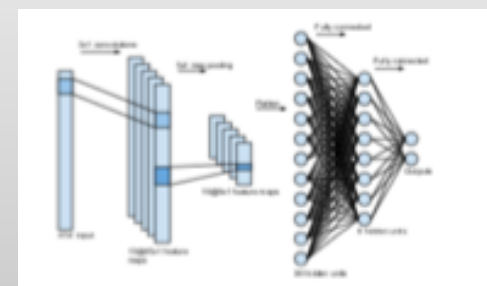

# Key Ideas for HL-LHC

Deep Combination of Spatio-Temporal Data

Graph and End-End Representation Learning

Tensor decomposition (towards trigger)

Compositionality, causal modeling (inference)

Unsupervised learning and physics

# Open Questions

How to quantify uncertainty

First principles models

Model interpretability

What features are learned

# Symbolic AI for HEP

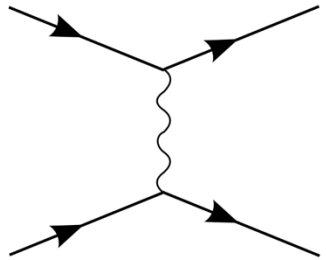

$$\longrightarrow i\mathcal{M} \longrightarrow |\mathcal{M}|^2$$

- Polarization Averaging
- Lorentz index
- Color factors
- Matrix multiplication
- Dirac algebra
- Traces
- Integration

$$\sigma \sim |\mathcal{M}|^2$$

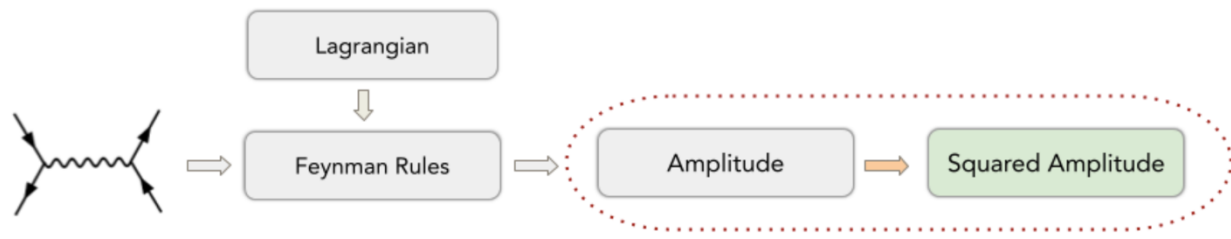
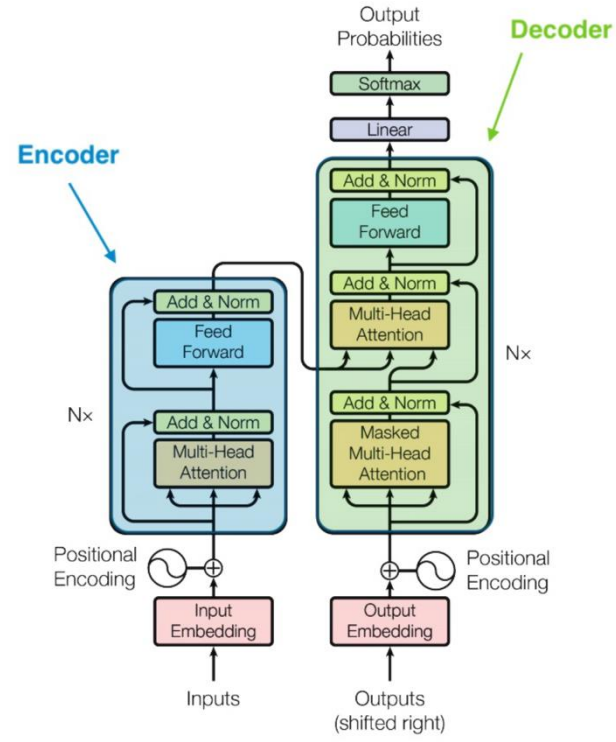

**Alnuqaydan et al. (2023)**

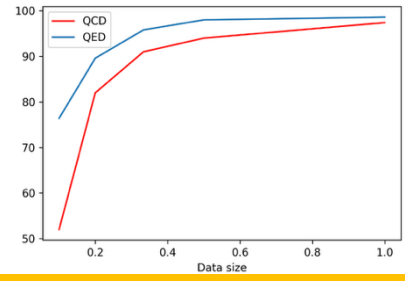

# A Glimpse of the Future

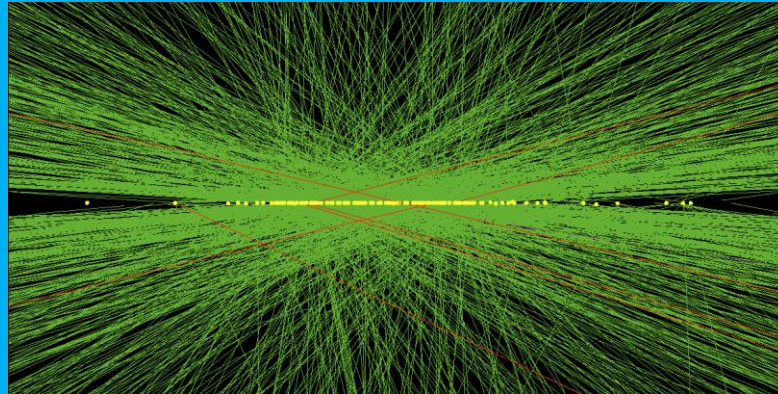

## Quantum Machine Learning

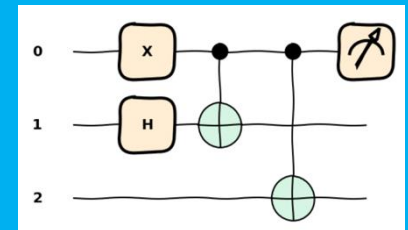

# Quantum ML for HEP

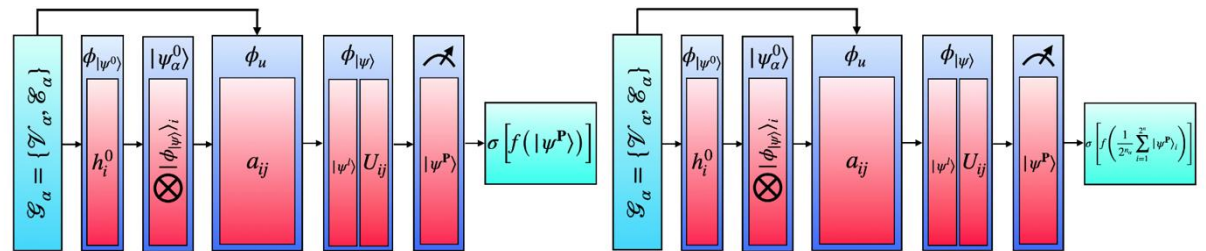
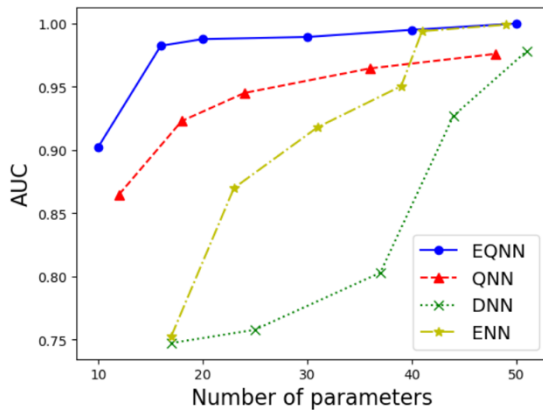

## QGAN, QDNN, QGNN, QVIT, EQNN

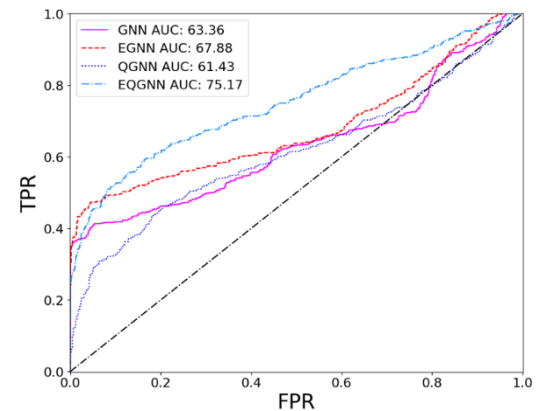
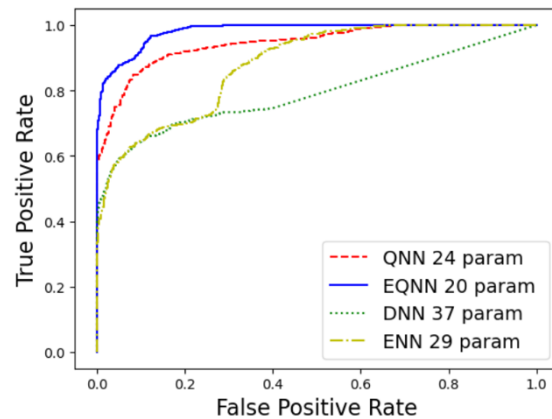
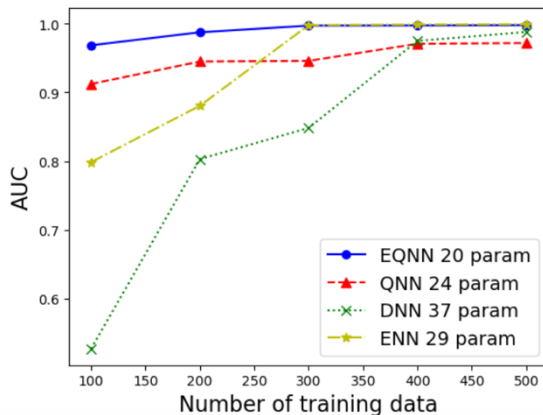

Forestano et al., Dong et al., Comajoan Cara et al., Unlu et al.

# Machine Learning 4 Science

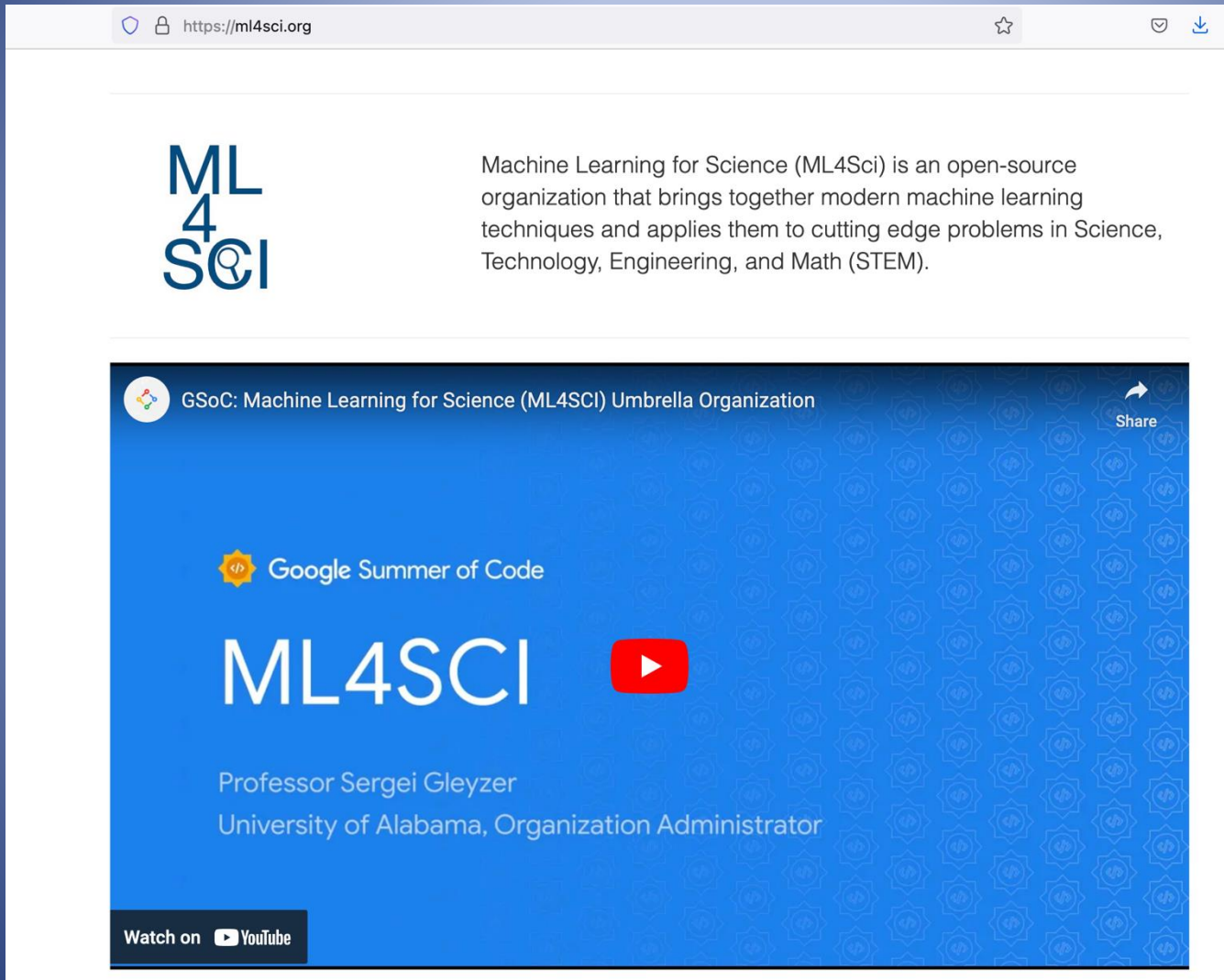

The screenshot shows the ML4Sci website homepage. At the top left is the ML4Sci logo. To its right is a paragraph: "Machine Learning for Science (ML4Sci) is an open-source organization that brings together modern machine learning techniques and applies them to cutting edge problems in Science, Technology, Engineering, and Math (STEM)." Below this is a video player for a Google Summer of Code presentation. The video title is "GSoc: Machine Learning for Science (ML4Sci) Umbrella Organization". The video content features the ML4Sci logo, the Google Summer of Code logo, and text identifying Professor Sergei Gleyzer as the University of Alabama Organization Administrator. A "Watch on YouTube" button is visible at the bottom left of the video player.



# Summary

- **We are taking steps towards answering fundamental questions about the Universe**
- **Will require progress to extract all the knowledge we seek from the scientific**
- **Advanced Deep Learning is a powerful tool to help us achieve these goals for reconstruction, simulation and realtime applications**

# THANK YOU



CMS Experiment at the LHC, CERN  
Data recorded: 2015-Jun-03 08:48:32.279552 GMT  
Run / Event / LS: 246908 / 77874559 / 86



**Questions?**

**Email: [sgleyzer@ua.edu](mailto:sgleyzer@ua.edu)**

