

# Direct Neutron Capture Reactions in a Storage Ring

**Iris Dillmann**

Senior Research Scientist (TRIUMF)  
Adjunct Professor (University of Victoria)

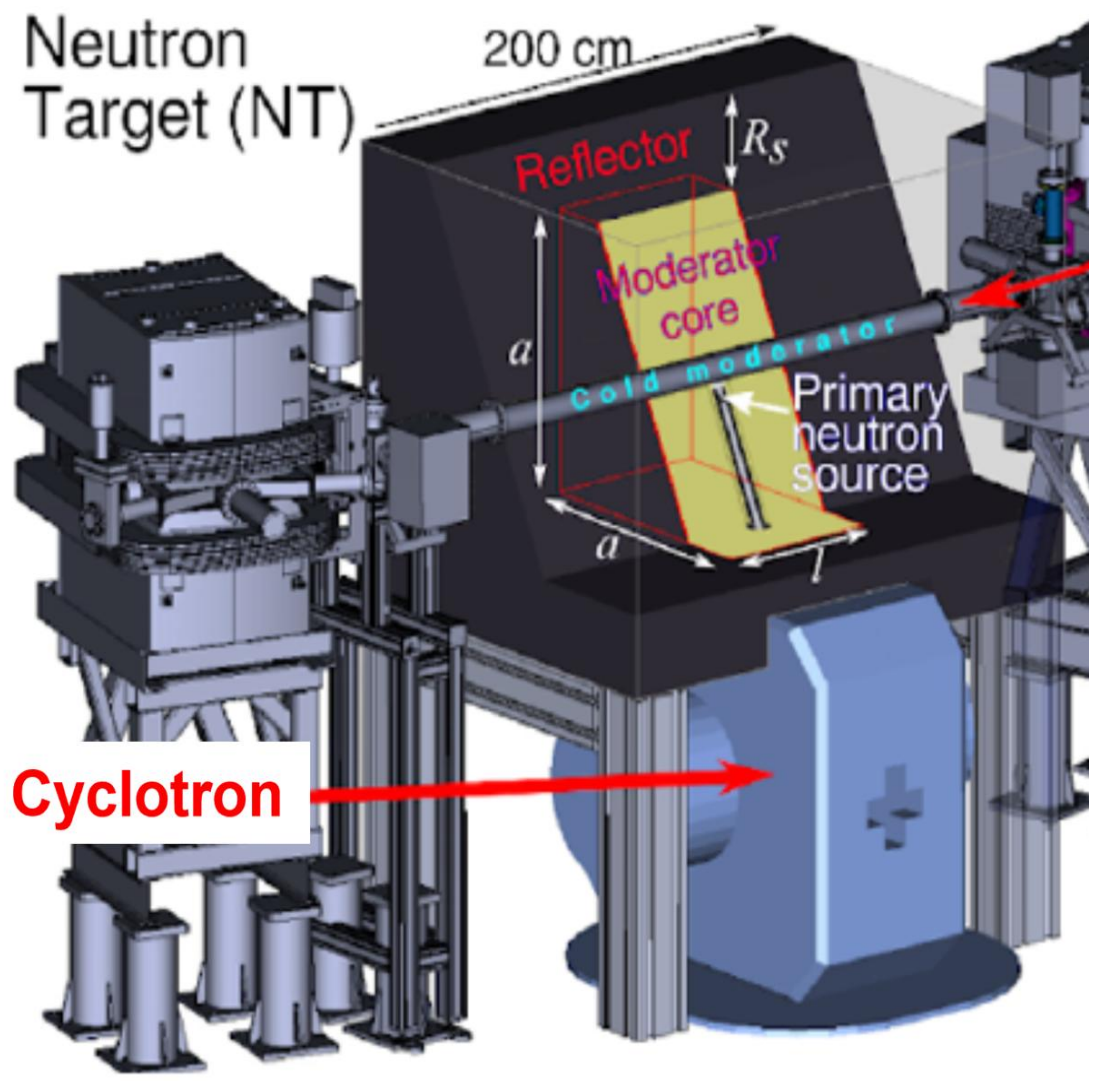

# Stellar (n, $\gamma$ ) Measurements: Status Quo

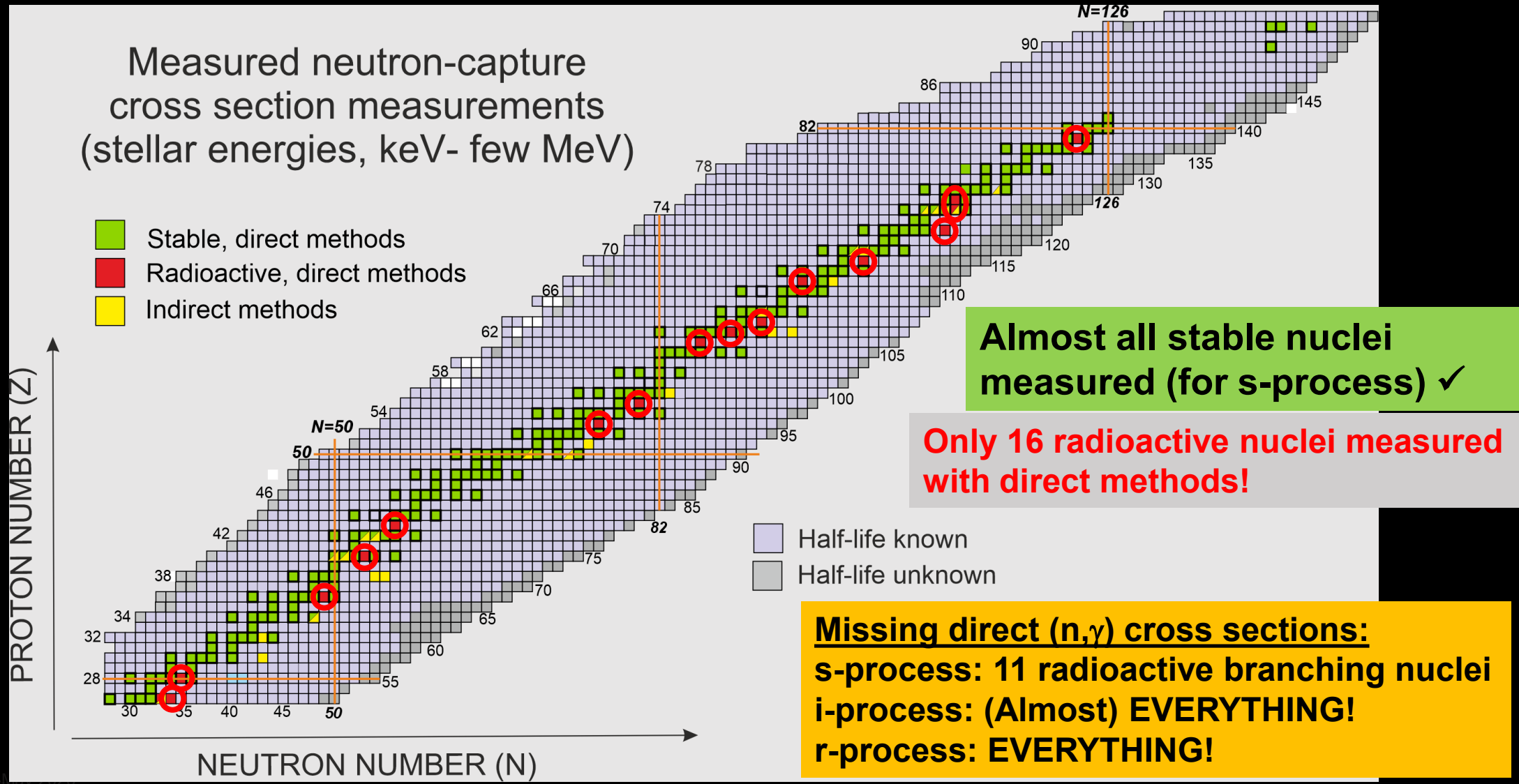

# Comparison to theory

“The effect of parameter uncertainties on the final nucleosynthesis is in the same order as model uncertainties, suggesting the **crucial need for more experimental constraints on key nuclei of interest... relevant (n,γ) rates impacting the i-process tracers, could enhance tremendously the prediction of stellar evolution models by experimentally constraining them.**”



- Parameter unc. for two nuclear models with two different combinations of NLD and PSF with TALYS

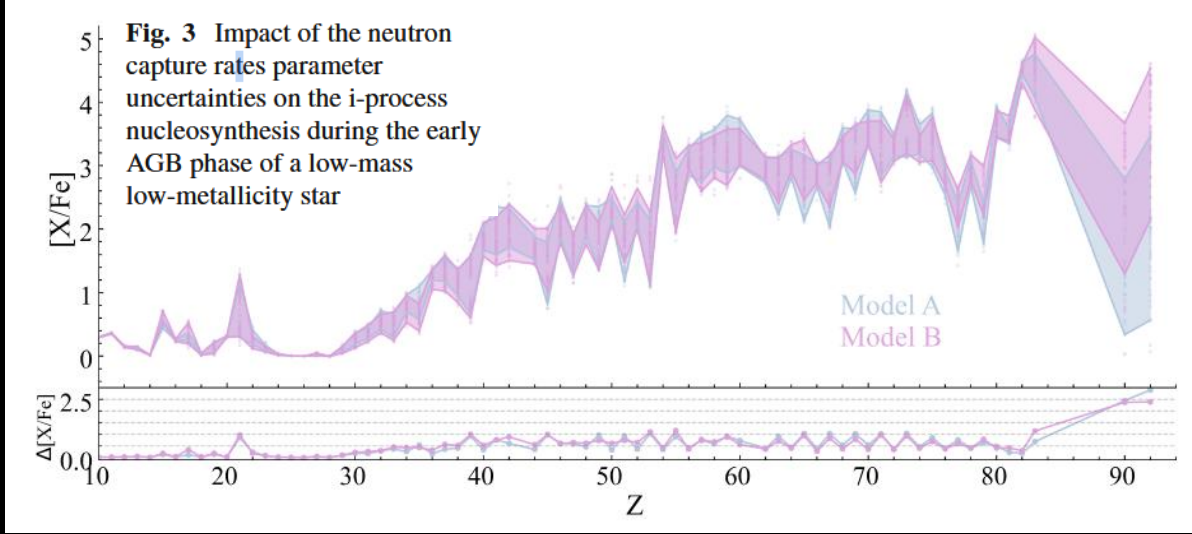
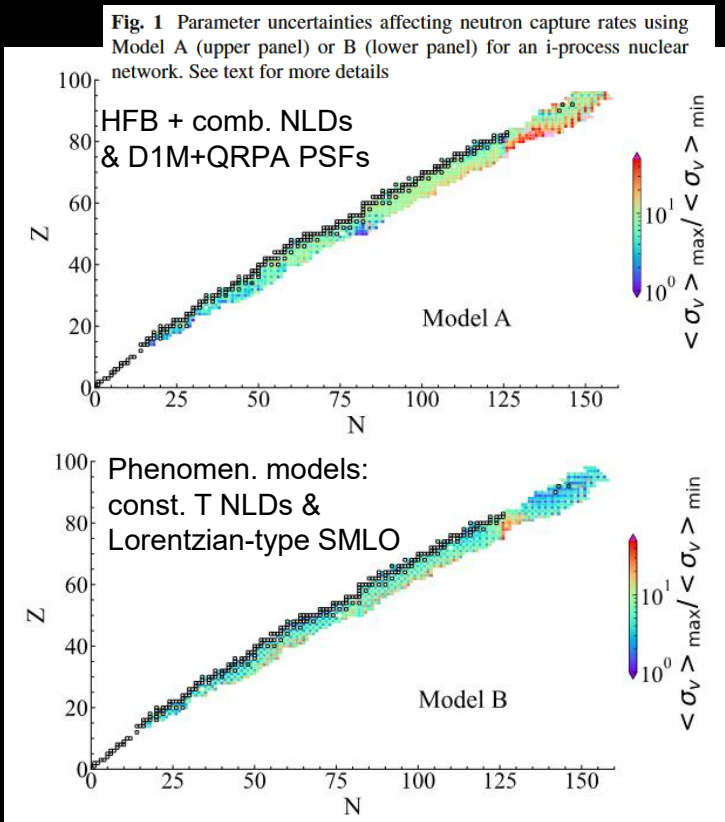

S. Martinet, S. Goriely, A. Choplin, and L. Siess, Eur. Phys. J. A61 (2025) 48  
<https://doi.org/10.1140/epja/s10050-025-01510-y>

# Neutron capture reactions

What are present limitations in direct captures?

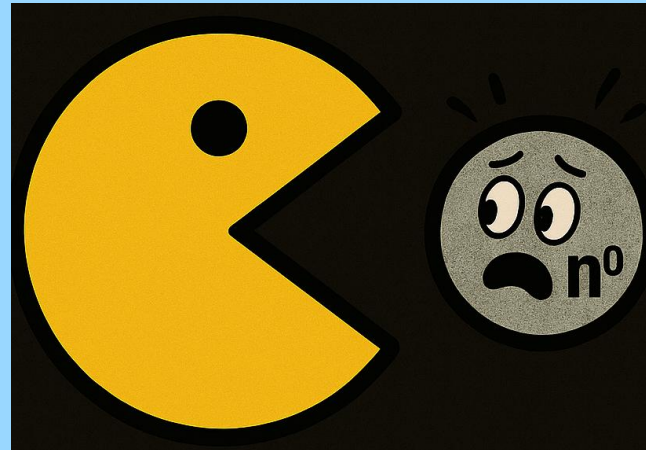

# How to measure direct neutron cross sections?

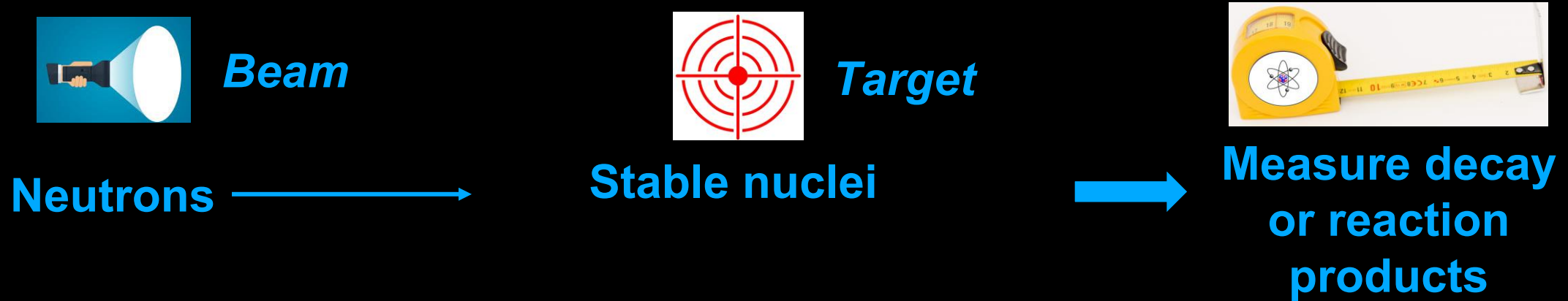

Typical “stellar” energies: 100’s eV - ~2 MeV  
Typical stellar (n, $\gamma$ ) cross section: 1-100’s mb

# Direct neutron activations with radioactive samples



*Beam*

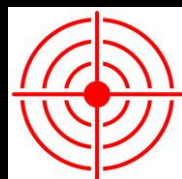

*Target*

Neutrons



Long-lived nuclei

sample size

- $^{63}\text{Ni}$ : 112 mg =  $1.1 \cdot 10^{21}$  atoms,  $A = 240 \text{ GBq}$  (= 6.5 Curie)

C. Lederer et al., PRC 89, 025810 (2014)

- $^{171}\text{Tm}$ : 3.1 mg =  $1 \cdot 10^{19}$  atoms,  $A = 114 \text{ GBq}$

C. Guerrero et al., PRL 125 (2020)



- $^{60}\text{Fe}$ : 1.35  $\mu\text{g}$  =  $1.35 \cdot 10^{16}$  atoms,  $A = 113 \text{ Bq}$

E. Uberseder et al., PRL 102, 151101 (2009)

- $^{179}\text{Ta}$ : 46 ng =  $1.58 \cdot 10^{14}$  atoms,  $A = 2 \text{ MBq}$

only thermal activation in reactor

R. Garg et al., PRC (2023)

Ni 63
100 a
$\beta^-$ 0,07
no $\gamma$
$\sigma$ 24

Tm 171
1,92 a
$\beta^-$ 0,1...
$\gamma$ (67); $e^-$
$\sigma \sim 160$

Fe 60
2.62 My
$\beta^-$ 0,1
m

Ta 179
665 d
$\epsilon$
no $\gamma$
g

## Direct stellar neutron activation: Limitations

- “Physical” sample size  **$>10^{14}$  atoms** needed ( $\sim 16$  ng for  $A=100$ )
- Shortest half-life measured so far:  **$t_{1/2} = 1.92$  y ( $^{171}\text{Tm}$ )**

For  $t_{1/2} < 100$  days:

- Sample production and preparation difficult (quick turn-around needed, high sample activity)
- Measurement needs to be done within days

**→ Not feasible for many nuclei unless activation facility, chemical separation, and measurement facility nearby**



# How to measure cross sections?



**Beam**



**Target**



**Neutrons**



**Stable/ long-lived nuclei**  
down to  $\sim 10^{15}$  atoms



**Measure decay or reaction products**

**Neutrons**



**Short-lived nuclei**



*“Inverse kinematics”*  
**Short-lived nuclei**



**Gas/ Solid**



**Measure decay and/or reaction products**

**Neutrons**  
 $t_{1/2} \sim 10^{-14}$  s



*Indirect measurements*

**Deuterium**  
*(d,p) reactions*



**Measure decay and/or reaction products**

# “Per aspera ad astra”

(“Through hardship to the stars”)

## How can we measure direct capture reactions with a storage ring?

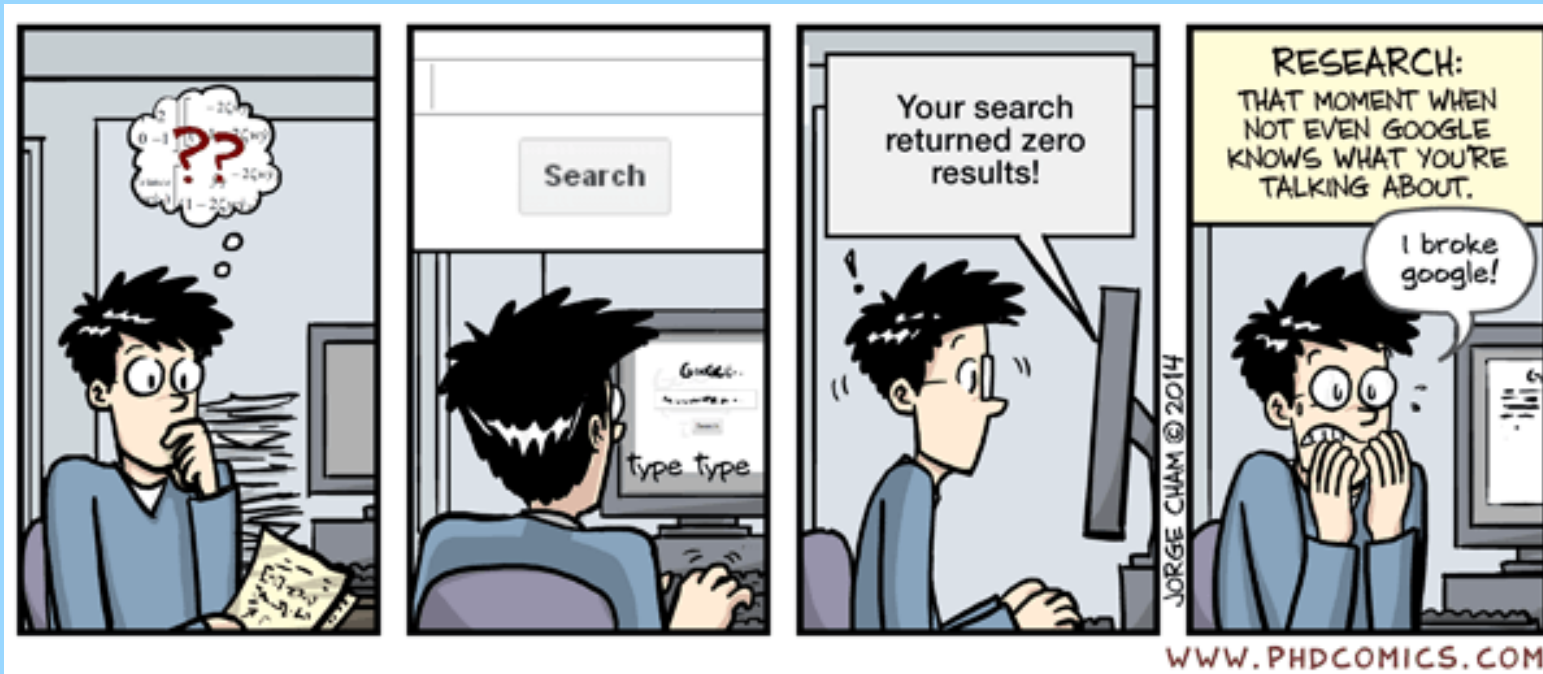

LEGO J.B. Ghost Lab

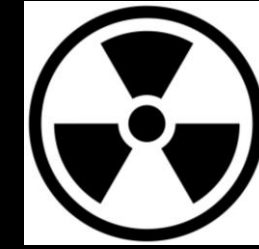

Operational  
Under construction  
Postponed  
Proposed  
Cancelled/closed

# (Modern) Heavy RIB Storage Rings

Fragmentation facility

- **Experimental Storage Ring (ESR) at GSI Darmstadt (since 1990)**
- Cooler-Storage Ring (CSRe) at HIRF in Lanzhou (since 2010)
- Rare RI Ring (R3) at RIKEN Nishina Center (since 2012)
- **CRYRING at GSI Darmstadt (1992-2014, since 2016)**
- Spectrometer Ring at HIAF in Huizhou (2025)
- **Collector Ring (CR) and High-Energy Storage Ring (HESR) at FAIR (>203x)**

ISOL facility

- ~~Test Storage Ring (TSR) at CERN-ISOLDE (2012)~~ (1988-2013)

Discovery,  
accelerated



# Reactions in a storage ring

1. Injection of (radioactive) beam
2. Beam is orbiting (100's kHz) and accumulated. Momentum spread can be reduced by cooling techniques
3. Beam orbit is changed to "interaction" orbit or target turned on (reactions)
4. Detection of reaction products inside or outside of ring / Ejection

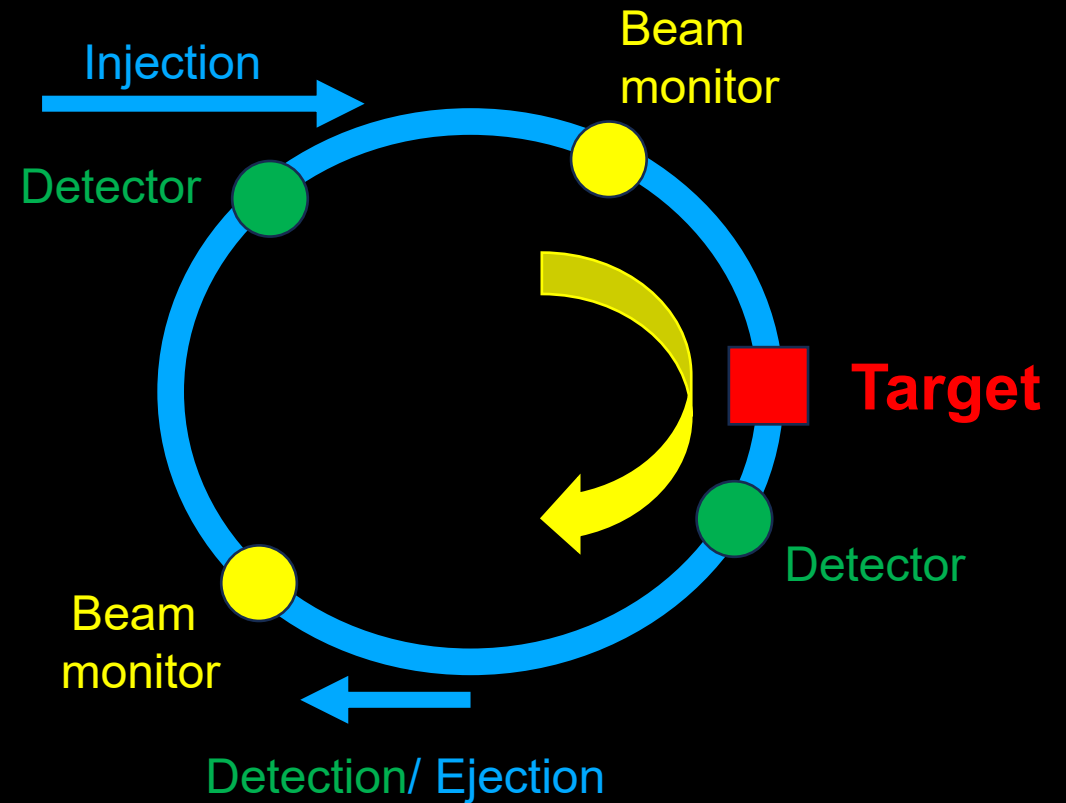



# Why storage rings? - Versatile Capabilities

**Unique environment!**

- Beam cooling, manipulation, accumulation, ...
- Long storage times (hours!)
- High charge states
- **Isomeric beams**
- **Multi-pass experiments (reactions)**

→ **Unique experiments!**

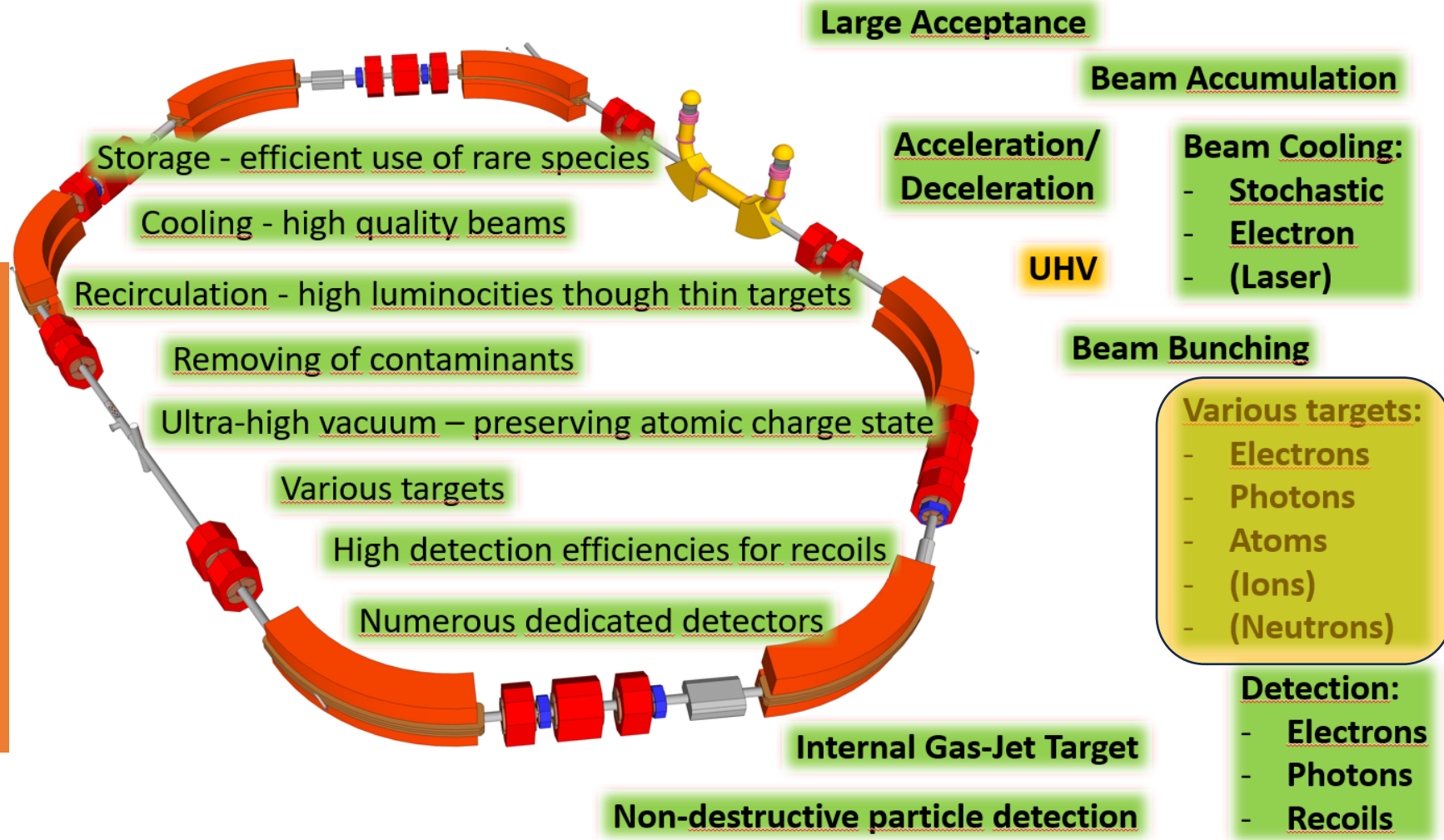

Slide from Yuri Litvinov



# What is next?



*Beam*



*Target*



Neutrons



Stable/ long-lived nuclei

>10<sup>14</sup> atoms



Measure decay or reaction products

Inverse kinematics:

Short-lived nuclei

Storage Ring

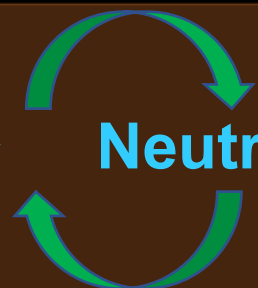

Neutrons



Measure reaction product

$$N_{A+1} = N_{A,ring} * \sigma(E) * \phi_n * f(E) * t_{meas} * \epsilon$$

>100 kHz

# Storage Ring + “Neutron target”

PHYSICAL REVIEW SPECIAL TOPICS - ACCELERATORS AND BEAMS 17, 014701 (2014)

## Measurements of neutron-induced reactions in inverse kinematics

René Reifarth<sup>1</sup> and Yuri A. Litvinov<sup>2,3</sup>

<sup>1</sup>Goethe-Universität Frankfurt am Main, Max-von-Laue-Str.1, 60438 Frankfurt am Main, Germany

<sup>2</sup>GSI Helmholtzzentrum für Schwerionenforschung, 64291 Darmstadt, Germany

<sup>3</sup>Max-Planck-Institut für Kernphysik, 69117 Heidelberg, Germany

(Received 17 September 2013; published 10 January 2014)

Neutron capture cross sections of unstable isotopes are important for neutron induced nucleosynthesis as well as for technological applications. A combination of a radioactive beam facility, an ion storage ring and a high flux reactor would allow a direct measurement of neutron induced reactions over a wide energy range on isotopes with half lives down to minutes.

DOI: 10.1103/PhysRevSTAB.17.014701

PACS numbers: 25.40.Lw, 29.38.-c, 28.41.-i

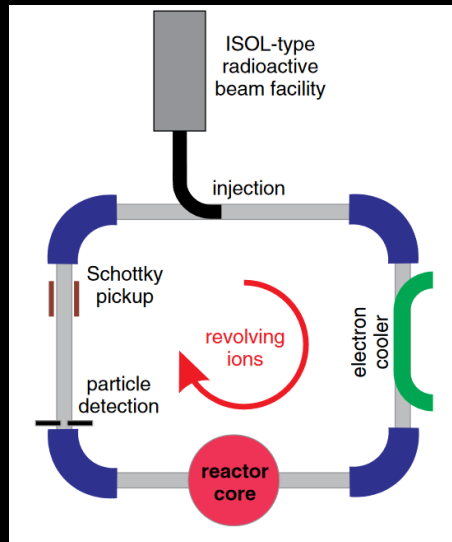

PHYSICAL REVIEW ACCELERATORS AND BEAMS 20, 044701 (2017)

## Spallation-based neutron target for direct studies of neutron-induced reactions in inverse kinematics

René Reifarth,<sup>\*</sup> Kathrin Göbel, Tanja Heftrich, and Mario Weigand  
Goethe-Universität Frankfurt, Frankfurt am Main, 60438 Frankfurt, Germany

Beatriz Jurado  
CENBG, 33175 Gradignan, France

Franz Käppeler  
Karlsruhe Institute of Technology, 76131 Karlsruhe, Germany

Yuri A. Litvinov  
GSI Helmholtzzentrum für Schwerionenforschung, 64291 Darmstadt, Germany  
(Received 29 November 2016; published 6 April 2017)

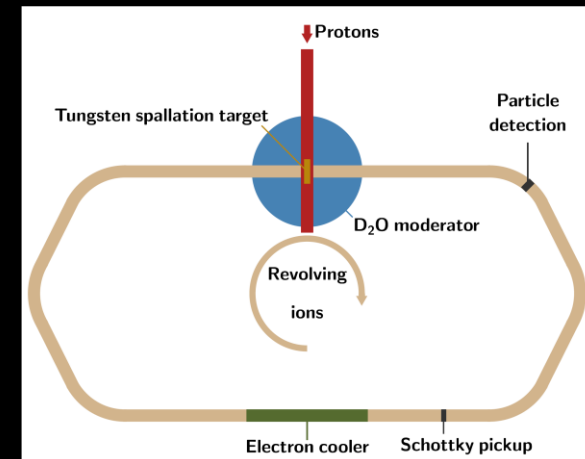

See Los Alamos Project  
(S. Mosby, A. Couture, R. Reifarth)

# (Little) Problem

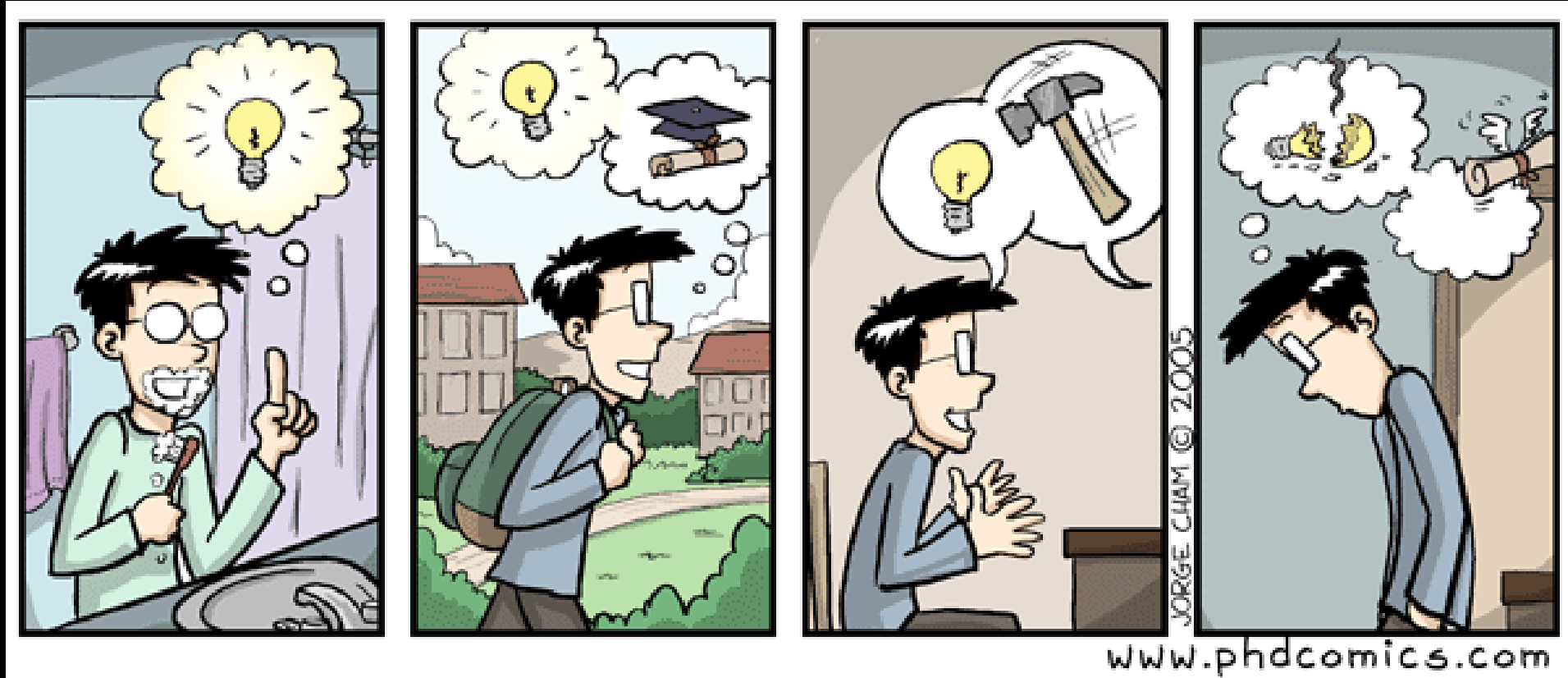

**No facility (yet) with RIB + Storage Ring  
+ Neutron Target**

# How to build a facility no one has built before

1. Find ambitious nuclear physicists who are crazy enough to do this



## The Four NRING Musketeers



*Submitted to Physical Review Accelerators and Beams*

**Direct Neutron Reactions in Storage Rings Utilizing a Supercompact Cyclotron  
Neutron Target**

Ariel Tarifeño-Saldivia\* and César Domingo-Pardo  
*Instituto de Física Corpuscular (CSIC-Universitat de València), Valencia, Spain*

Iris Dillmann  
*TRIUMF, Vancouver BC, Canada and  
Department of Physics and Astronomy, University of Victoria, Victoria BC, Canada*

Yuri A. Litvinov  
*GSI Helmholtzzentrum für Schwerionenforschung GmbH, Darmstadt, Germany and  
Institut für Kernphysik, Universität zu Köln, Köln, Germany*  
(Dated: August 22, 2025)

Accepted!!!

<https://arxiv.org/pdf/2508.15465>

# How to build a facility no one has built before

2. Find a suitable existing storage ring for proof-of-concept facility



**CRYRING**

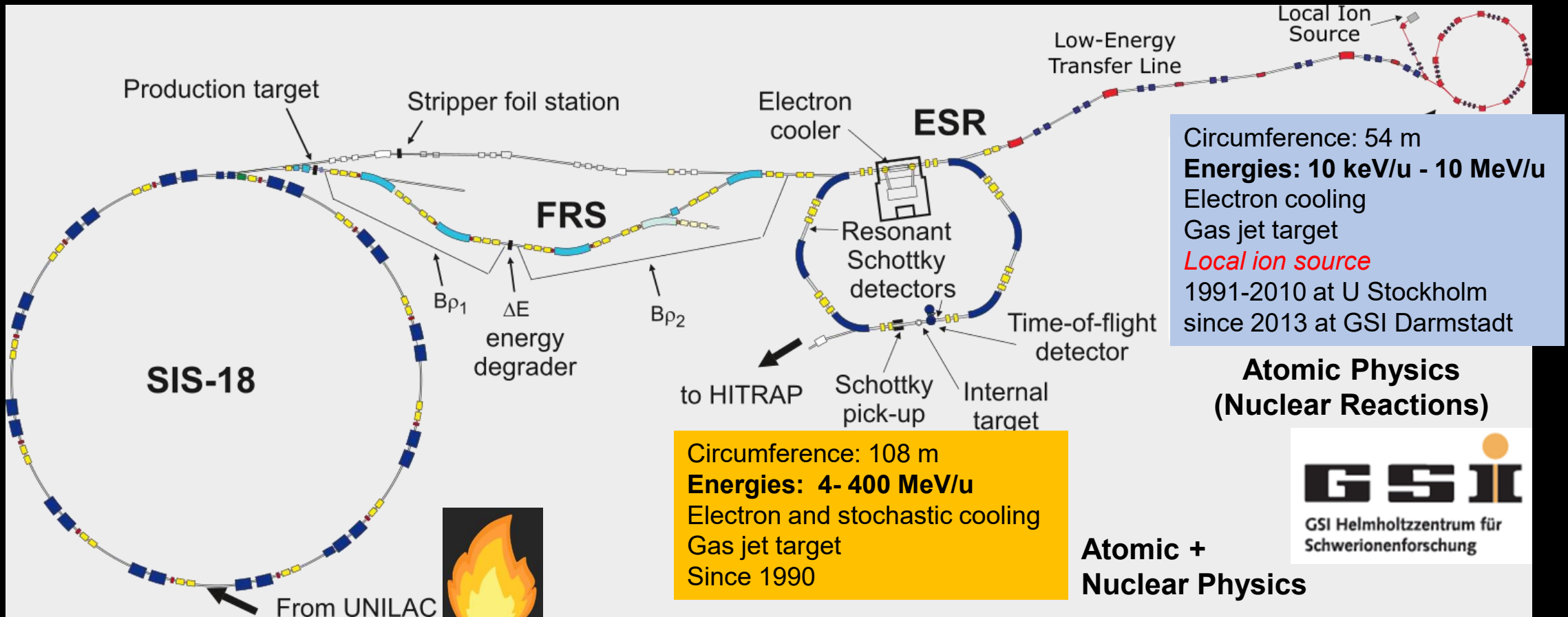

Circumference: 54 m  
**Energies: 10 keV/u - 10 MeV/u**  
 Electron cooling  
 Gas jet target  
*Local ion source*  
 1991-2010 at U Stockholm  
 since 2013 at GSI Darmstadt

Circumference: 108 m  
**Energies: 4- 400 MeV/u**  
 Electron and stochastic cooling  
 Gas jet target  
 Since 1990

**Atomic Physics  
 (Nuclear Reactions)**



**Atomic +  
 Nuclear Physics**



# How to build a facility no one has built before

## 3. Find money to build a suitable neutron moderator/target (in progress)

Demonstrator assembly at CRYRING@GSI Darmstadt

- (Cryogenic) Neutron moderator-reflector target
- Supercompact cyclotron: 9 MeV p,  $\sim 130 \mu\text{A} \rightarrow {}^9\text{Be}(p,xn)$

→ **Expected areal neutron density:  $\sim 3 \cdot 10^6 \text{ n/cm}^2$**

→ Few events/ day with 100 mb

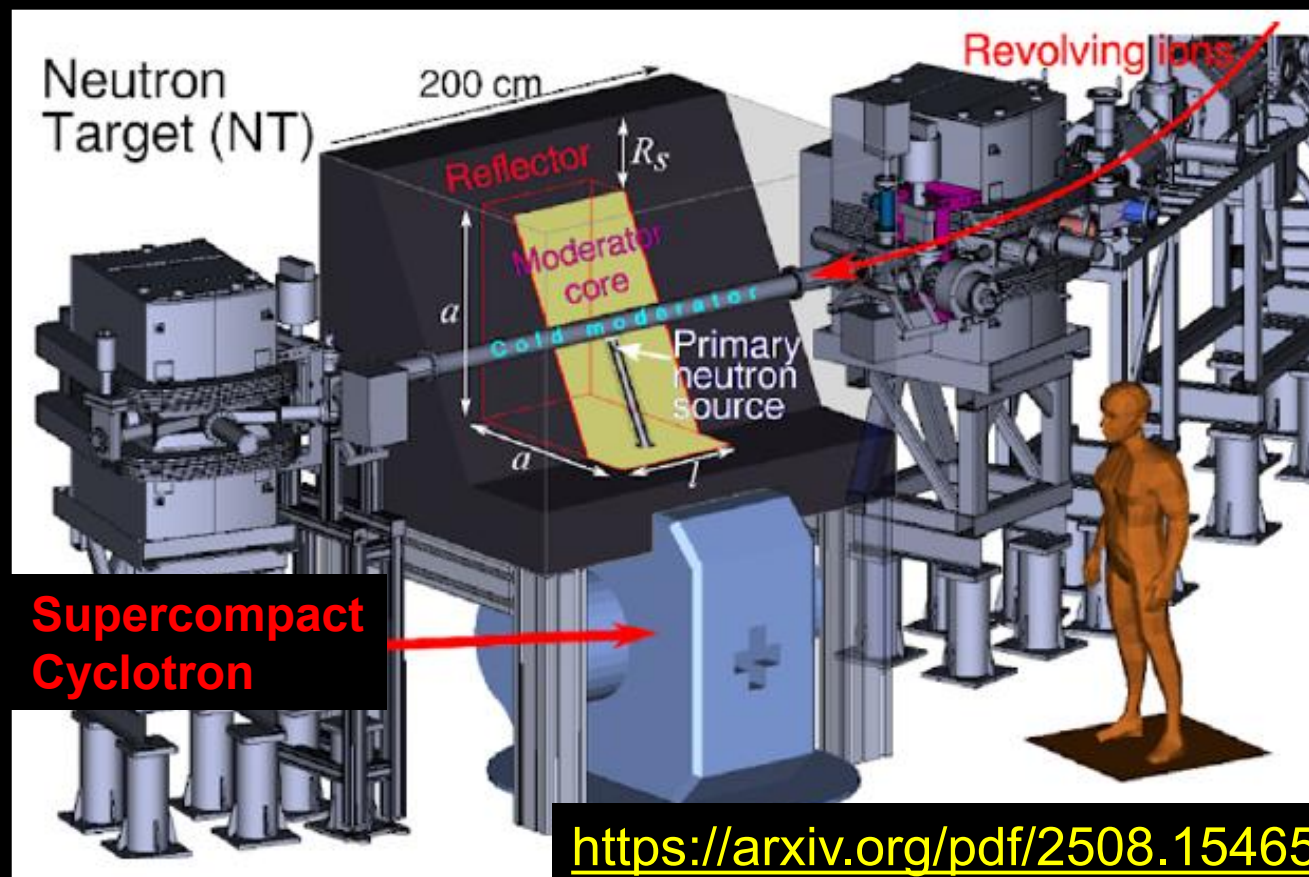

<https://arxiv.org/pdf/2508.15465>

# How to build a facility no one has built before

## 4. Identify suitable “high”-statistics experiments



- Start easy: **Stable beams** from local ion source ( $^{20}\text{Ne}$ )
- Start with **known detection technology**: In-ring particle detection for (n,p) and (n, $\alpha$ ) reactions at  $E= 4\text{-}15 \text{ MeV/u}$
- $10^9\text{-}10^{10} \text{ }^{20}\text{Ne}^{3+}$  stored  $\rightarrow$  **Expected rates**  
 300-2000 events/day for (n, $\alpha$ );  
 20-1000 events/day for (n,p)

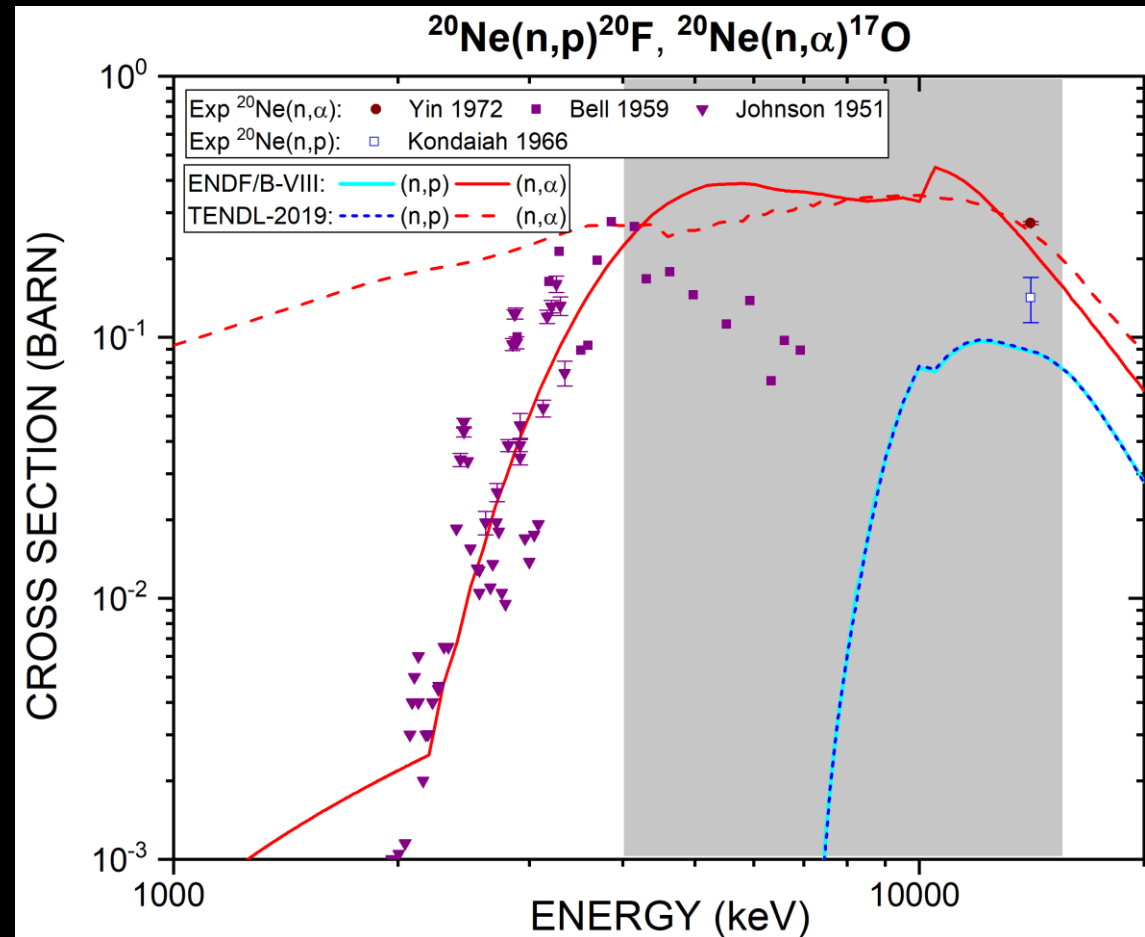

# How to build a facility no one has built before

## 5. Increase complexity: $(n, \gamma)$ requires a Wien filter

- Beam and  $(n, \gamma)$  product cannot be distinguished inside ring (momentum conservation)
- But: Different velocities!  
 → Extraction into **Wien velocity filter**  
 → Full separation after 3 m drift length

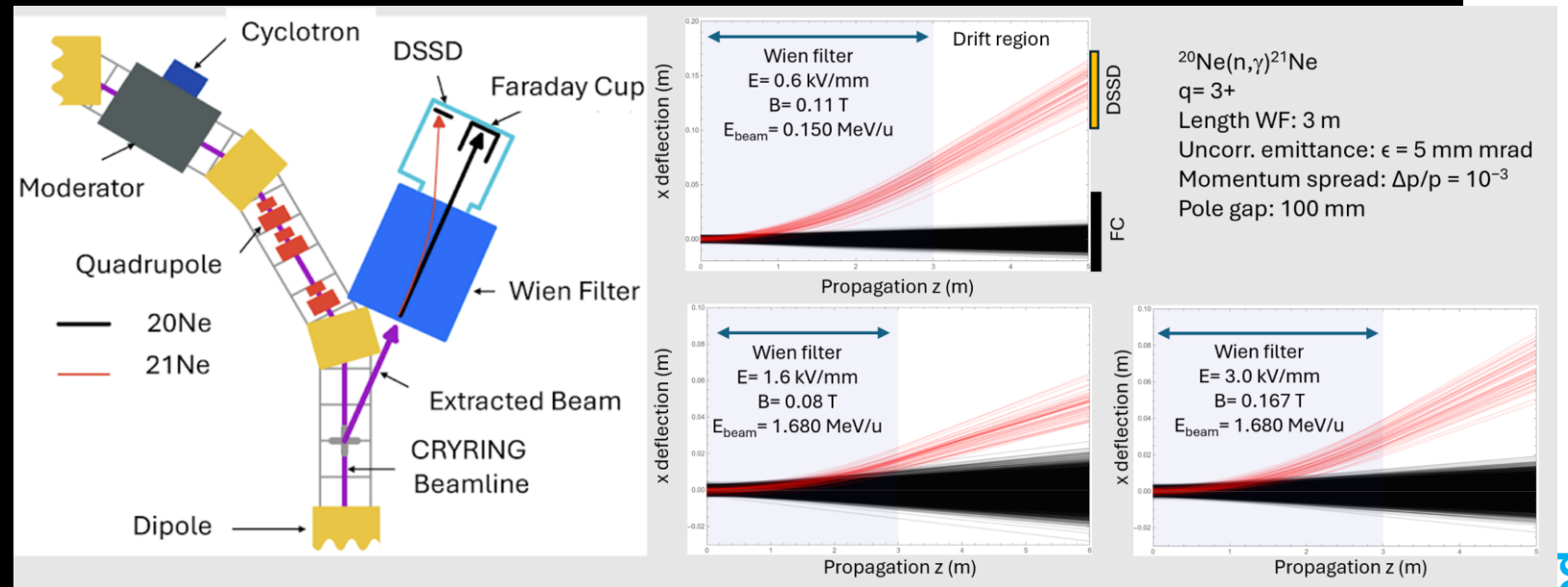

- Detection via Faraday Cup (beam) and DSSD (reaction products)

# How to build a facility no one has built before

## 5. Increase complexity

- $^{20}\text{Ne}(n,\gamma)$ : Known resonances at 147 keV, 1.37 and 1.68 MeV
- $1.2 \cdot 10^9$   $^{20}\text{Ne}^{3+}$  ions in ring
- ~20 events/day for 1.37/1.68 MeV
- few events/day at 147 keV

$$N_{A+1} = N_{A,\text{ring}} * \sigma(E) * \phi_n * f(E) * t_{\text{meas}} * \varepsilon$$

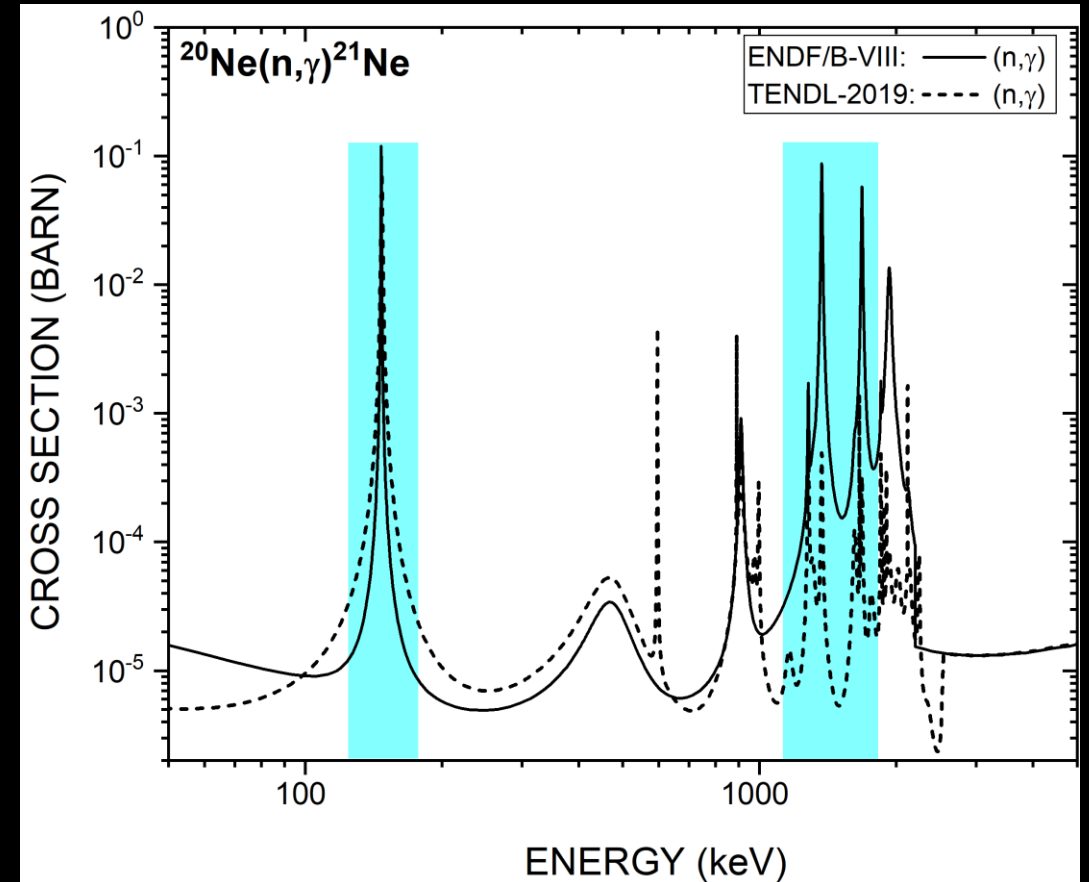

Disadvantage of in-flight RIB facility:  
Huuuge losses → limited number of cases

Increase complexity more:

→ Long-lived radioactive beam

→ Short(er)-lived radioactive beam

# How to build a facility no one has built before

## 6. Propose a dedicated “ideal” neutron capture storage ring

- Design a storage ring without space constraints
- Use a better & higher intensity proton driver for neutron production
- Use a better RIB facility → ISOL
- Increase duty factor by including Wien Filter separation into ring
- Detect reaction products with recoil separator

# Outlook: The TRIUMF Storage Ring Project

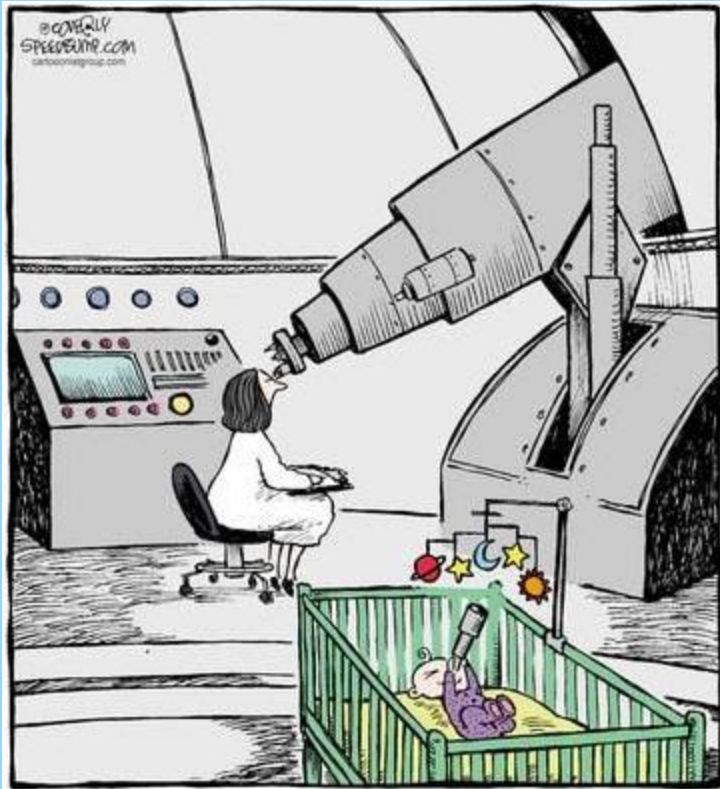

Eur. Phys. J. A (2023) 59:105  
<https://doi.org/10.1140/epja/s10050-023-01012-9>

THE EUROPEAN  
PHYSICAL JOURNAL A



Regular Article - Experimental Physics

## Measuring neutron capture cross sections of radioactive nuclei

From activations at the FZK Van de Graaff to direct neutron captures in inverse kinematics with a storage ring at TRIUMF

Iris Dillmann<sup>1,2,a</sup>, Oliver Kester<sup>1,2</sup>, Richard Baartman<sup>1,2</sup>, Alan Chen<sup>3</sup>, Tobias Junginger<sup>1,2</sup>, Falk Herwig<sup>2</sup>, Dobrin Kaltchev<sup>1</sup>, Annika Lennarz<sup>1,3</sup>, Thomas Planche<sup>1,2</sup>, Chris Ruiz<sup>1,2</sup>, Nicole Vassh<sup>1</sup>

<sup>1</sup> TRIUMF, Vancouver, BC V6T 2A3, Canada

<sup>2</sup> Department of Physics and Astronomy, University of Victoria, Victoria, BC V8P 5C2, Canada

<sup>3</sup> Department of Physics and Astronomy, McMaster University, Hamilton, ON L8S 4M1, Canada

Received: 23 December 2022 / Accepted: 13 April 2023

© The Author(s) 2023

Communicated by Nicolas Alamanos

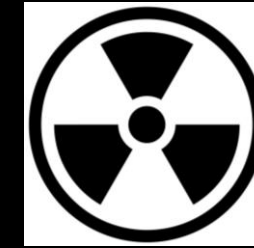

Operational  
 Under construction  
 Postponed  
 Proposed  
 Cancelled/closed

# (Modern) Heavy RIB Storage Rings

Fragmentation facility

- Experimental Storage Ring (ESR) at GSI Darmstadt (since 1990)
- Cooler-Storage Ring (CSRe) at HIRF in Lanzhou (since 2010)
- Rare RI Ring (R3) at RIKEN Nishina Center (since 2012)
- **CRYRING at GSI Darmstadt (1992-2014, since 2016)** NRING project
- Spectrometer Ring at HIAF in Huizhou (2025)
- Collector Ring (CR) and High-Energy Storage Ring (HESR) at FAIR (>203x)

**+ Neutron Target**

ISOL facility

- ~~Test Storage Ring (TSR) at CERN-ISOLDE (2012)~~ (1988-2013)
- ISOLDE Storage Ring (ISR, proposed) at CERN-ISOLDE (>203x)
- **TRIUMF Storage Ring (TRISR, proposed) at TRIUMF-ISAC (>203x)** TRISR project
- Los Alamos Storage Ring (proposed) at LANSCE (>203x?)

Discovery,  
accelerated

# The TRIUMF Storage Ring (TRISR) Project

Existing ISOL facility + Storage Ring + Neutron Target = TRISR

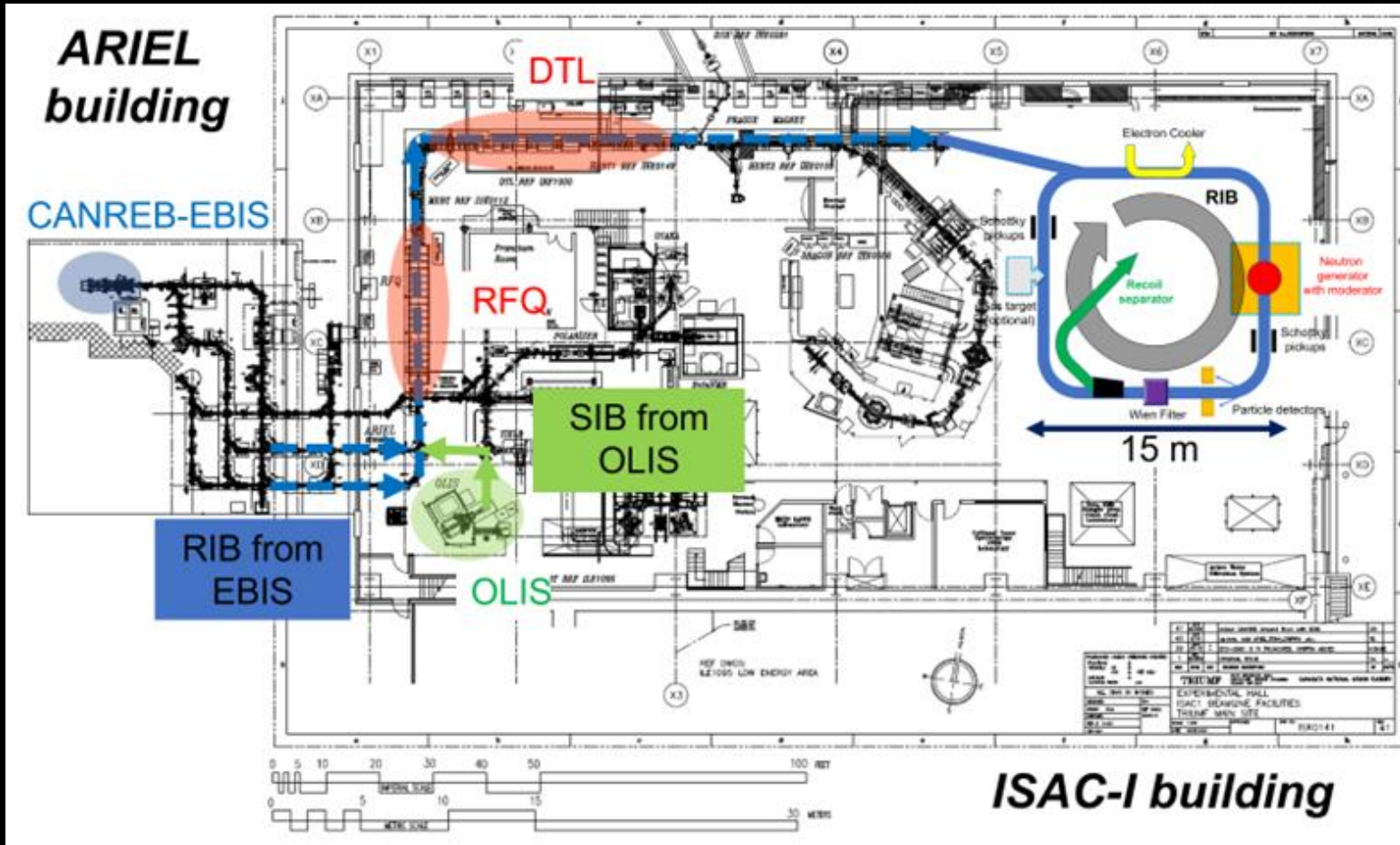

(n,γ) cross sections  
for  $A > 50$   
at astrophysical  
energies

$E = 150 - 2000 \text{ keV/u}$

# Possible Design: TRISR at TRIUMF

Direct neutron capture reactions on radioactive nuclei!

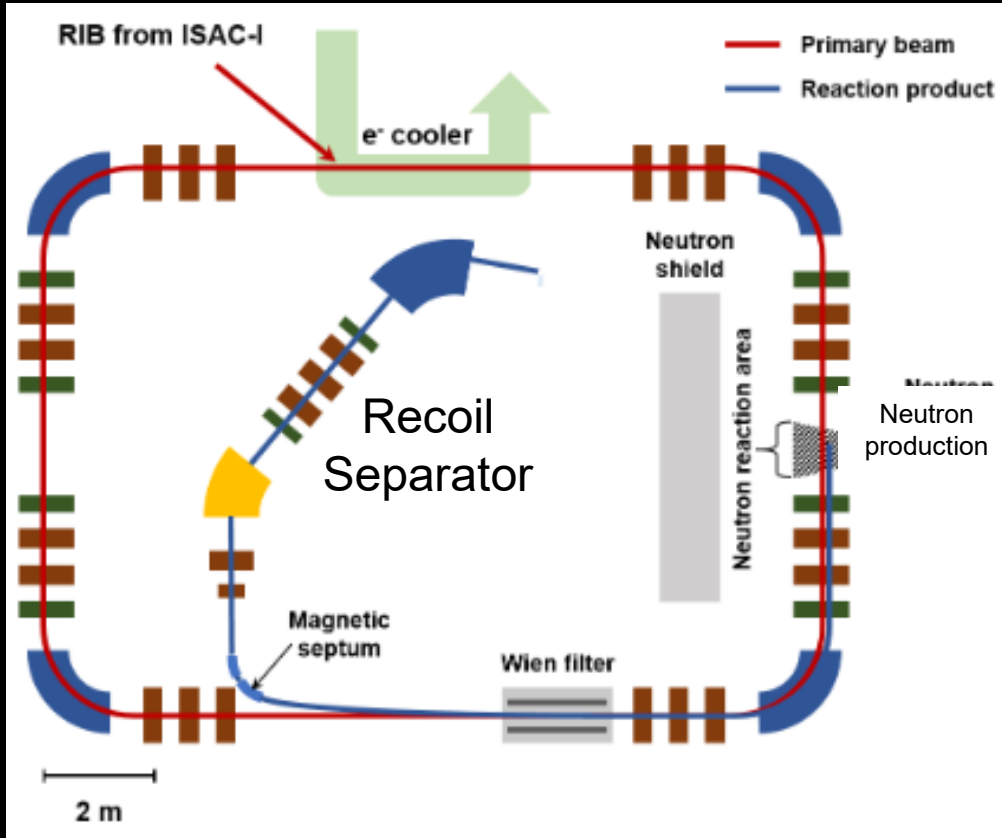

- Connected to ISAC facility
- Direct injection at energy of interest (150-2000 keV/u)
- Neutron production tbd.
- Wien filter inside ring matrix
- Detection by recoil separator



*Several orders of magnitude gain*

**Possible scaled areal neutron density:  $\sim 10^9$  n/cm<sup>2</sup>**  
**→ nxs down to few mb!**

I. Dillmann et al., EPJA 59, 105 (2023)  
 K. Pak et al., Nucl. Eng. Techn. 57 (2025) 103392  
 A. Tarifeno-Saldivia et al., Phys. Rev. Accel. Beams (2026),  
<https://arxiv.org/abs/2508.15465>

# Accessible Nuclei with Future Facility

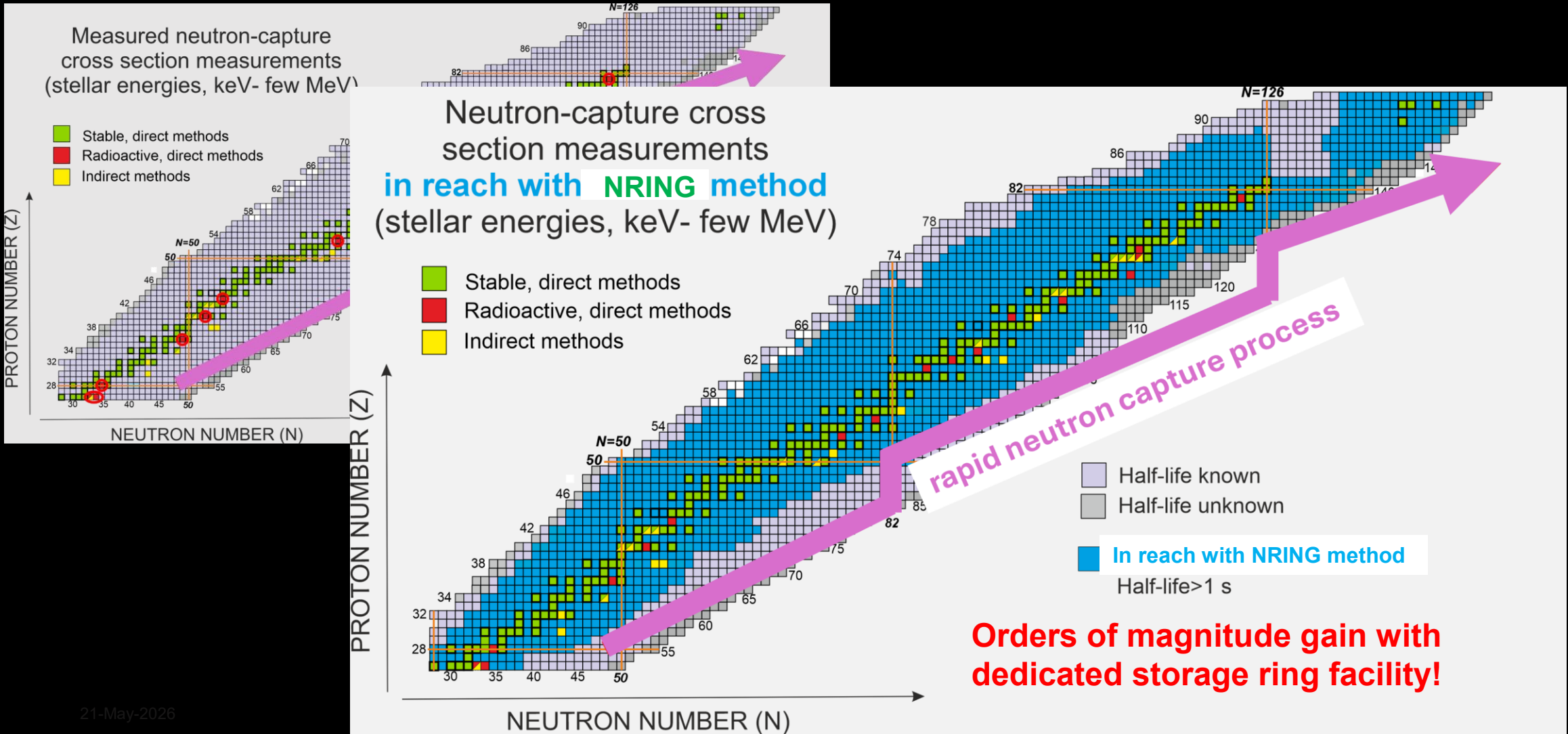

# Summary

	NRING@GSI	TRISR@TRIUMF	LANL
<b>Storage Ring</b>	CRYRING (existing)	<i>TRISR*</i>	<i>(LANL Ring)*</i>
<b>Proton Driver</b>	<i>Compact cyclotron*</i>	Cyclotron* or CANS*	800 MeV Linac
<b>Neutron production</b>	${}^9\text{Be}(p,xn)$	${}^9\text{Be}(p,xn)$ ; (d,n); ...	n spallation
<b>Energy range</b>	50 keV/u- 30 MeV/u	150 keV/u- 2 MeV/u	>5 MeV/u
<b>RIB Production</b>	In-flight facility (existing)	ISOL (existing)	<i>ISOL*, long-lived ions</i>
<b>Separation</b>	Extraction + <i>Wien filter*</i>	<i>In-ring Wien filter*</i>	tba
<b>Recoil detection</b>	<i>DSSD*</i>	<i>Recoil separator*</i>	tba
<b>Physics goal</b>	(n, $\gamma$ ), (n,p), (n, $\alpha$ )	Mainly (n, $\gamma$ )	(n,xn), (n, $\gamma$ )
<b>Shortest <math>t_{1/2}</math></b>	min	~10s	tba (several y...10s)
<b>Funding</b>	ERC (under review)	Design study (funded)	Design study, target demonstrator (funded)



Thank You!  
Merci!  
hay č x<sup>w</sup> q'ə!

[www.triumf.ca](http://www.triumf.ca)

@TRIUMFLab



## Key Factor: Neutron Target Design

- High-Flux Reactor: Very high flux **but very expensive**
- Spallation Neutron Source: High flux **but still expensive**
- (Compact) Acc-Driven Neutron Source: Good flux but large size
- **High-intensity cyclotron-driven neutron source**
- **Compact cyclotron-driven neutron source: Best compromise**
- Array of compact neutron generators: scalable and needs space
- Neutron Generator: **Lower neutron flux and cheap**

# The Cryogenic Moderator-Reflector

- D<sub>2</sub>O or BeO ceramics as moderator
- Graphite as reflector
- 20 K liquid H<sub>2</sub> as cryogenic material

→ ~14-15\*10<sup>-7</sup> n/cm<sup>2</sup>/primary

Storage ring beampipe  
(diameter ~1 cm!)

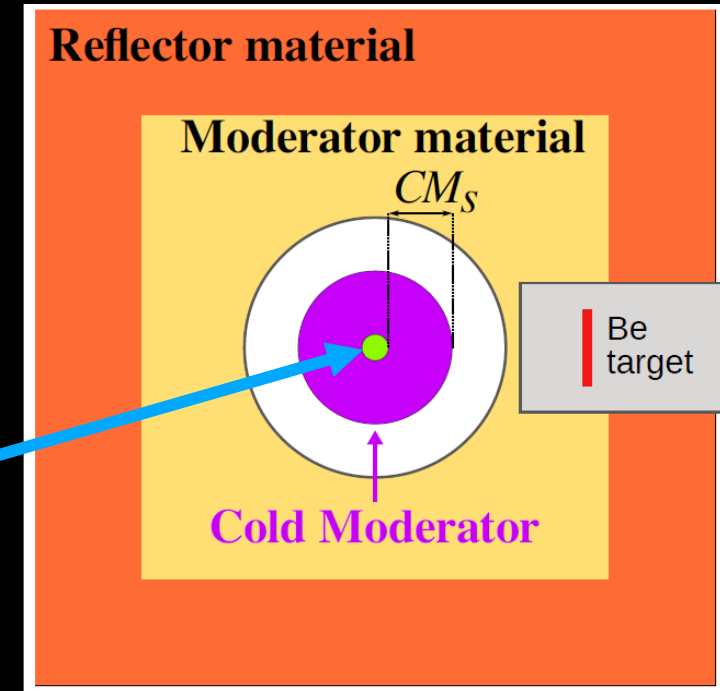

TABLE II. Final proposed configurations for the compact neutron target optimized for storage-ring integration.

Configuration	Moderator		Reflector		Cold Moderator		Proton Energy $E_p$ [MeV]	Thermal Areal Density $A_{den}$ [10 <sup>-7</sup> n/cm <sup>2</sup> /prim]	
	Material	$a$ [cm]	$l$ [cm]	Material	$R_s$ [cm]	Material Temp. [K]			$CM_s$ [mm]
$C_1$	D <sub>2</sub> O	70	70	graphite	50	LH <sub>2</sub> 20	13	5–10	14.3–15.0
$C_2$	BeO	50	44	graphite	50	LH <sub>2</sub> 20	13	>7	14.0–15.0

<https://arxiv.org/pdf/2508.15465>

# The Supercompact Cyclotron



TABLE III. Selection of commercial compact proton cyclotrons. Technical specifications and suitability for implementation of the free neutron target are based on proposed configuration with a D<sub>2</sub>O moderator (see configuration C<sub>1</sub> Table II). For proton energies up to 10 MeV, the total areal density is taken from calculations in Fig. 9. For proton energies larger than 10 MeV, calculations are assuming a thermal areal density per primary neutron  $A_{den} = 5 \times 10^{-7}$  n/cm<sup>2</sup>/prim and neutron yields from Ref. [18] ( $E_p > 10$  MeV).

Manufacturer	Model	Footprint (m <sup>2</sup> )	Weight (tons)	Proton Energy (MeV)	Max Current (μA)	Shielding	Thermal Areal Density (n/cm <sup>2</sup> )	Source
IBA	Cyclone KEY	1.5x1.4	7.5	9.2	130	Self-shielding (opt)	$3.4 \times 10^6$	[38]
Best	BG-95	< 2x2	22	9.5	120	Self-shielding	$3.3 \times 10^6$	[39, 40]
Best	B6-15/B15p	2.2x2.2	14	10	400 (550 <sup>a</sup> )	Self-shielding	$1.2 \times 10^7$	[41]
GE	PETtrace 800 series	1.33x1.2	20	16.5	160	Vault	$6.7 \times 10^6$	[42]
IBA	Cyclone KIUBE	1.9x1.9	18	18	300	Vault	$1.5 \times 10^7$	[43]
						Self-shielding (opt)		
ACSI	TR FLEX	1.7x1.7	24	22	800	Vault	$6.4 \times 10^7$	[44]
IBA	Cyclone IKON	2.2x2.2	30	22	1500	Vault	$1.2 \times 10^8$	[45]
ACSI	TR-30	2.4x2.4	50	22	1600	Vault	$1.3 \times 10^8$	[46]
IBA	Cyclone 70	4x4	120	30-70	750	Vault	-	[47, 48]

<sup>a</sup> Measured at Argonne National Laboratory

<https://www.iba-radiopharmasolutions.com/cyclotrons/cycloner-key-0/>

- IBA Cyclone KEY is **best solution for limited space in CRYRING**
- Protons up to 9.2 MeV, current up to 130 μA
- factor 10 in current for larger cyclotrons possible

<https://arxiv.org/pdf/2508.15465>

# Extraction of beam with a Wienfilter

## Conceptual Design of a Low-Energy Ion Beam Storage Ring and a Recoil Separator to Study Radiative Neutron Capture by Radioactive Ions

Kihong Pak

Department of Nuclear Engineering, Hanyang University,  
Seoul 04763, Republic of Korea

Barry Davids\*

TRIUMF, 4004 Wesbrook Mall, Vancouver, BC V6T 2A3, Canada and  
Department of Physics, Simon Fraser University,  
8888 University Drive, Burnaby, BC V5A 1S6, Canada

Yong Kyun Kim†

Department of Nuclear Engineering, Hanyang University,  
Seoul 04763, Republic of Korea

Recently, the TRIUMF Storage Ring (TRISR), a storage ring for the existing Isotope Separator and Accelerator-I (ISAC-I) radioactive ion beam facility at TRIUMF, was proposed. It may be possible to directly measure neutron-induced radiative capture reactions in inverse kinematics by combining the ring with a high-flux neutron generator as the neutron target. Herein, we present the conceptual design of a low-energy ion storage ring as well as a fusion product extraction system with a Wien filter and recoil separator for detecting neutron capture products based on ion optical calculations and particle-tracking simulations.

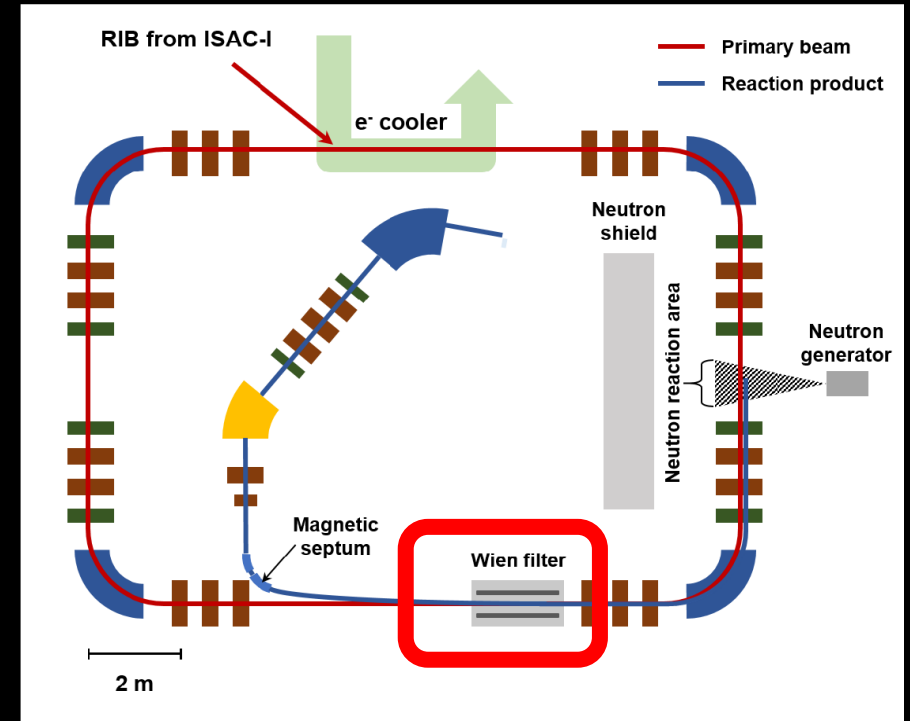

- Calculations done with COSY INFINITY
- Separate beam and reaction products with Wienfilter and magnetic septum - **never done before for a storage ring!**
- Extraction into recoil separator

K. Pak et al., Nucl. Eng. Techn. 57 (2025) 103392  
<https://arxiv.org/pdf/2312.11859.pdf>

# Extraction of beam with a Wien filter: $^{80}\text{Zn}(n,\gamma)^{81}\text{Zn}$

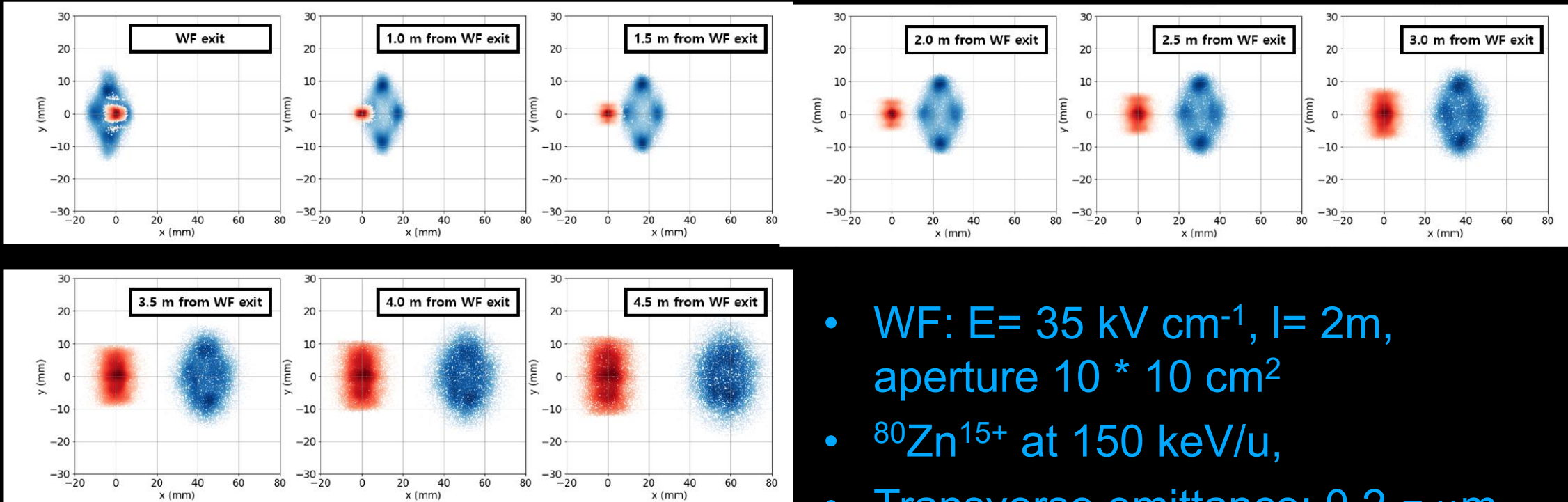
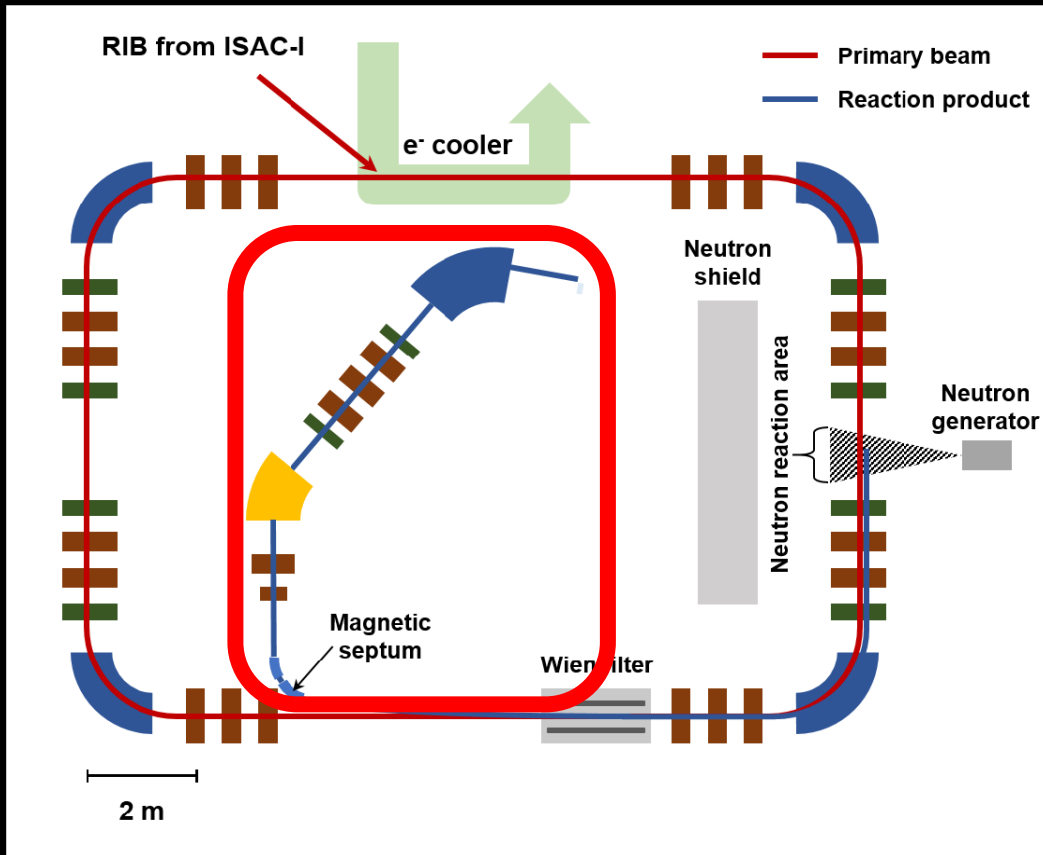

FIG. 5. Position distributions of the beam (red) and recoil (blue) ions after passing through the Wien filter at various downstream distances.

- WF:  $E = 35 \text{ kV cm}^{-1}$ ,  $l = 2 \text{ m}$ , aperture  $10 * 10 \text{ cm}^2$
- $^{80}\text{Zn}^{15+}$  at  $150 \text{ keV/u}$ ,
- Transverse emittance:  $0.2 \pi \mu\text{m}$
- Assume 1  $\gamma$  emitted after capture  
 →  $\sim 40 \text{ mm}$  separation of  $^{81}\text{Zn}^{15+}$  and  $^{80}\text{Zn}^{15+}$  after 4m → magnetic septum

# Conceptual recoil separator study



- Based on experiences and designs for DRAGON and EMMA
- 5Q, 2S, 40deg electrostatic deflector, 60deg magnetic dipole
- $L = 11 \text{ m}$

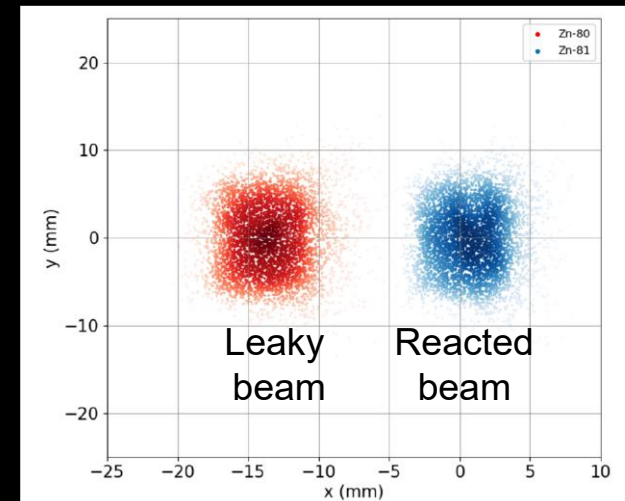

FIG. 10. Calculated position distributions of beam and recoil ions in the focal plane of the recoil separator.

K. Pak et al., Nucl. Eng. Techn. 57 (2025) 103392  
<https://arxiv.org/pdf/2312.11859.pdf>