

IMPERIAL



A metre-scale plasma discharge for plasma wakefield acceleration

Claudia Cobo, Louis Forrester, Bingxue Wu, Nuo Xu and Zulfikar Najmudin

Scalable Plasma Sources

- Large energy content of proton drivers allows single stage electron acceleration to TeV level
- AWAKE proof of principle demonstrations in 10 m rubidium vapour source (laser ionised)
- Need to scale up to > 100 m for particle physics applications

AWAKE requirements

- 0.1 Hz operation
- High reproducibility
- Plasma density: $n_e = 7 \times 10^{20} \text{ m}^{-3}$
- Transverse profile: constant n_e over 3 mm
- Axial uniformity: $\Delta n_e < 0.2 \%$ over 10 m

This talk

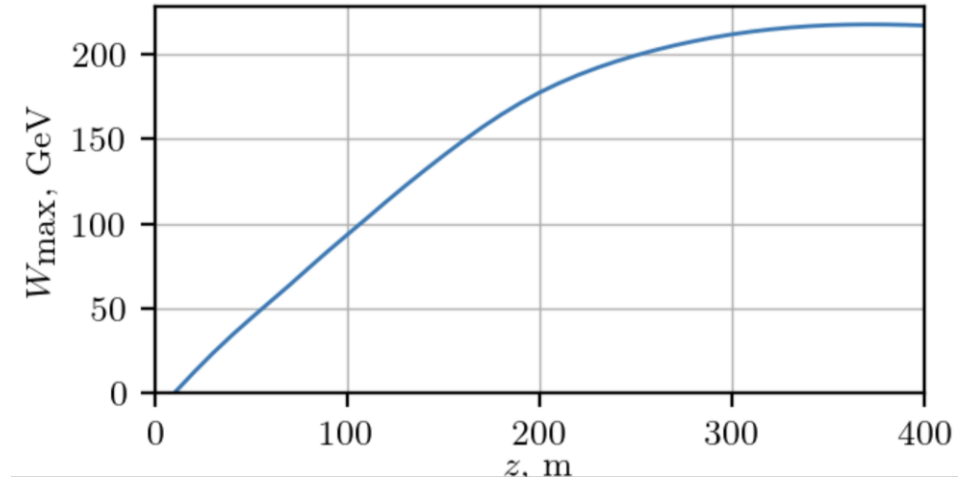

P. Tuev, K. Lotov, PPCF (2021)

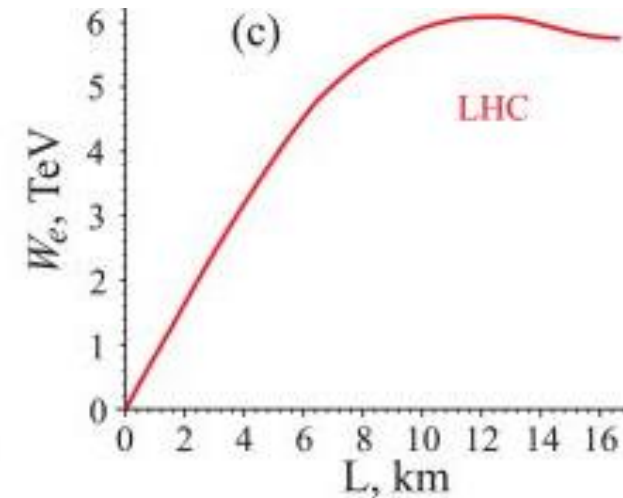

A. Caldwell and K. Lotov, PoP (2011)

Discharge Plasma Source at AWAKE



Discharge used in AWAKE tunnel

- Multiple gases, pressures, lengths

Enabled interesting physics measurements

- Filamentation of a relativistic proton bunch in plasma
- Ion motion in a resonantly driven PWFA
- Light diagnostics for wakefields at AWAKE

L. Verra *et al.* PRE (2024)

M. Turner *et al.* PRL (2025)

J. Mezger *et al.* NIMA (2025)

Discharge Plasma Source at ICL

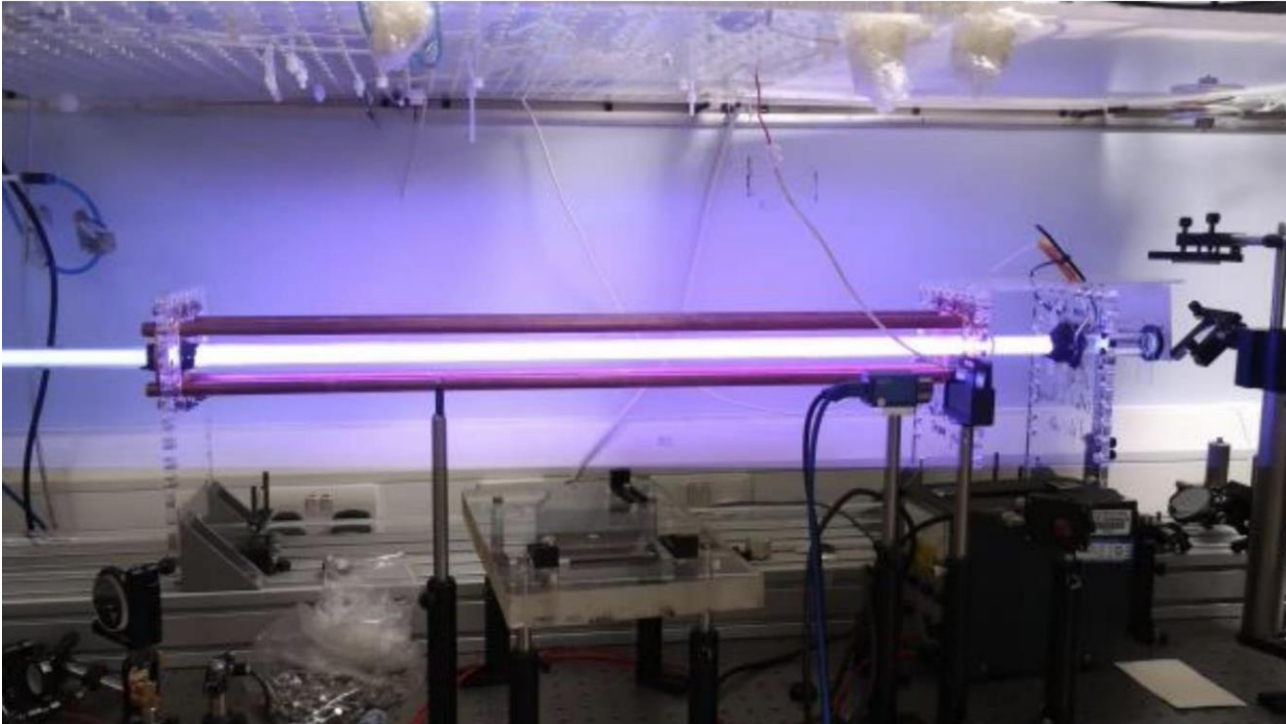

Parameter	ICL Value	CERN Value	Unit
Tube length	1	10	m
Diameter	19.5	26	mm
Discharge gap	15	25	cm
Gas pressure	0.01 – 1.5	0.01 – 1	mbar
Discharge current	100 – 500	100 – 500	A
Discharge time	0.5 – 100	~25	μ s

Plasma Formation

Voltage leak (~1 kV) produces glow discharge (~ mA)

- Weakly ionised plasma

Pulse generator (8 kV) drives ~100 A through plasma

Transition from glow to **arc discharge** plasma regime

- High ionisation level → high uniformity

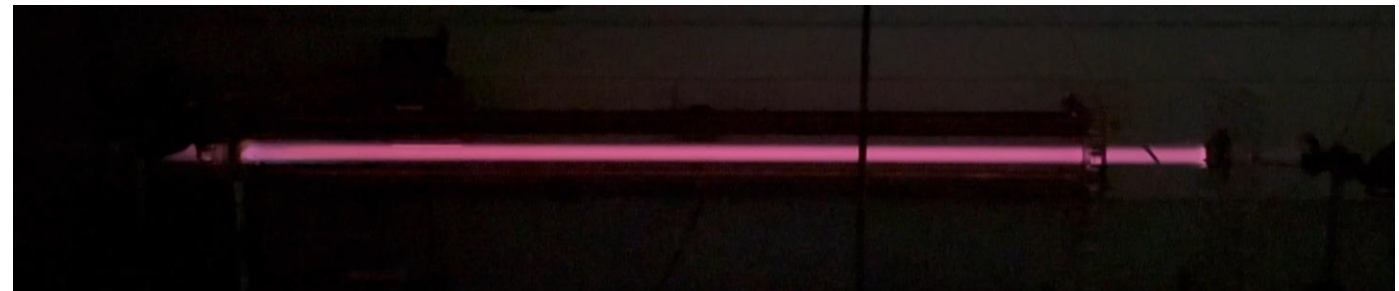
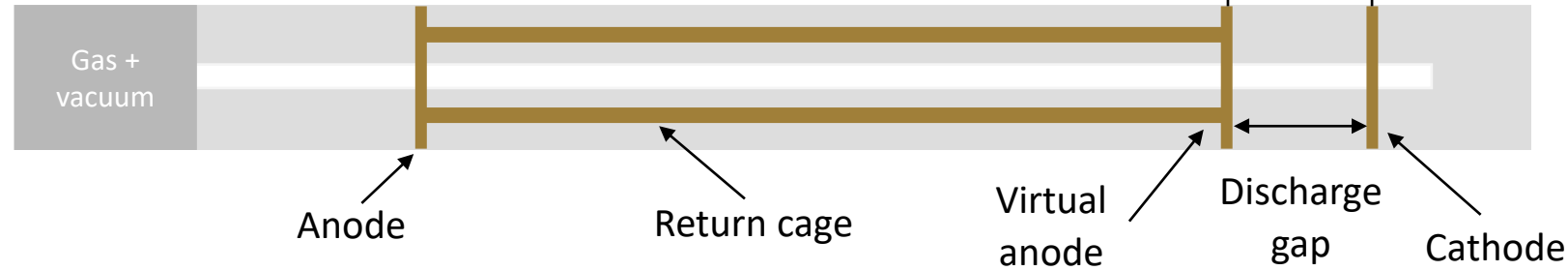
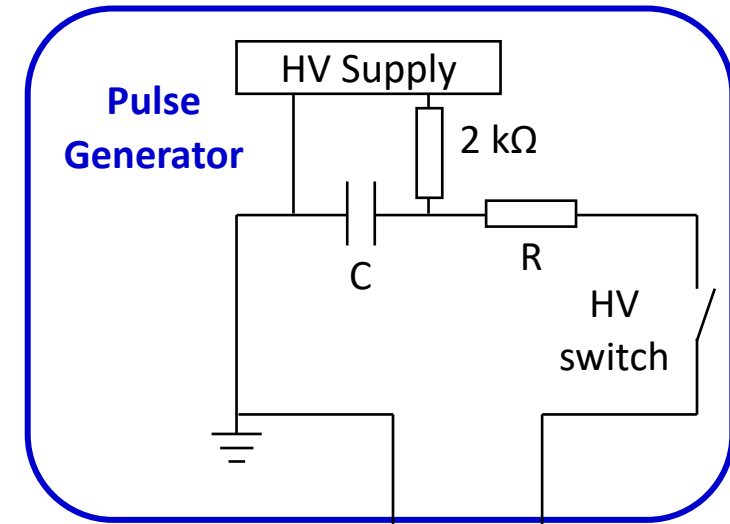
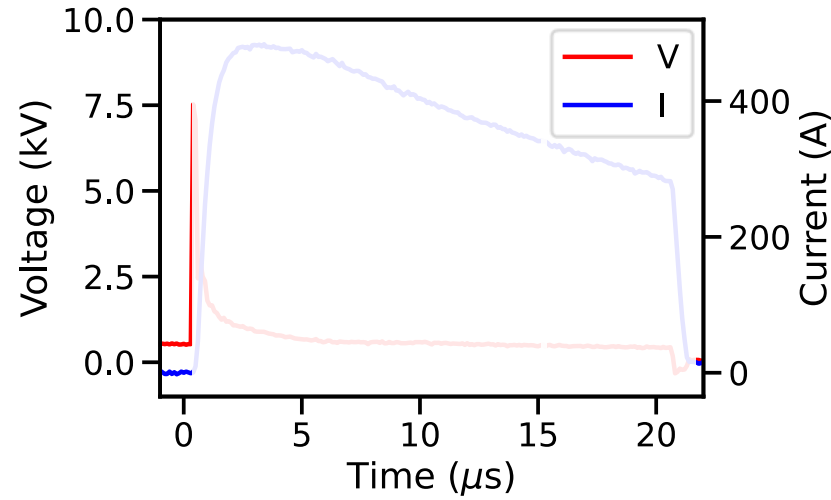

High Voltage Pulse Generator

- Semiconductor-based pulse generator
- Multi-stage optically isolated trigger
- Controllable pulse duration 0.5 – 100 μs

High repetition rate operation tested on resistive-inductive dummy load

- 630 A peak at 500 kHz
- 500 A peak at 1 MHz
- < ns jitter

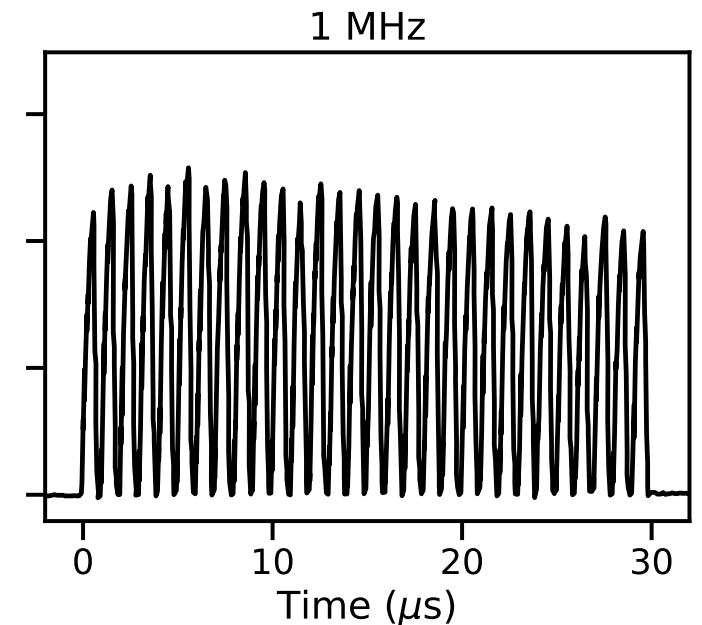
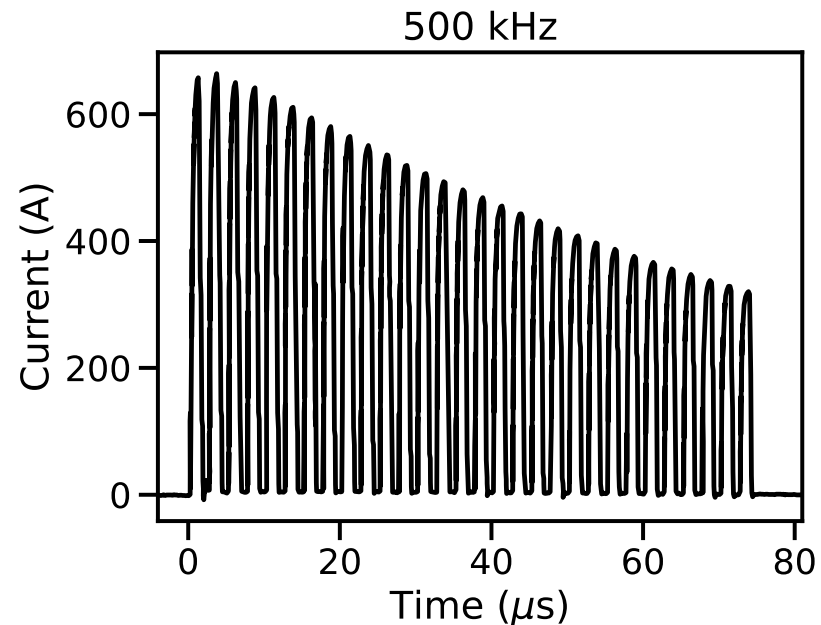
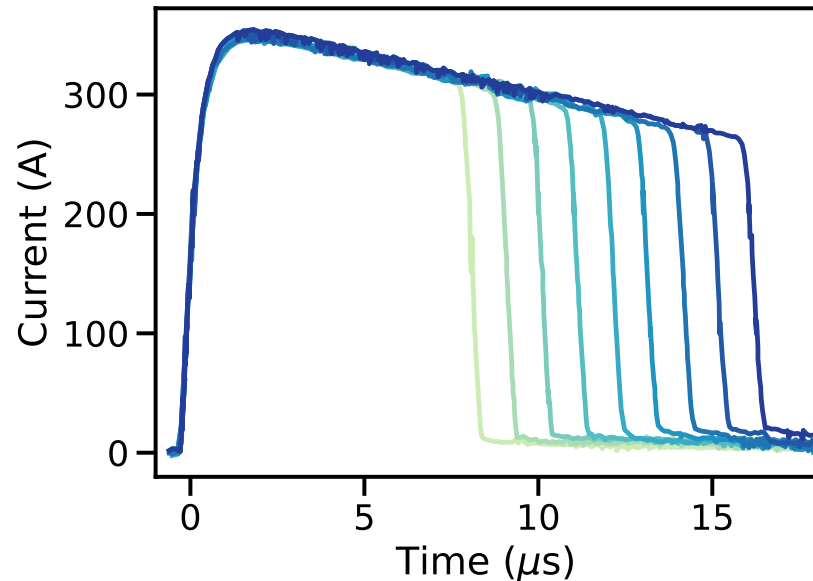
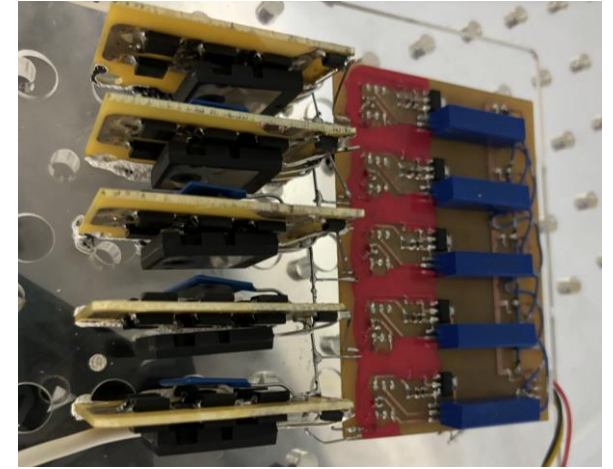

Discharge Reproducibility

Argon, 8 kV

Microsecond-level jitter of 330 A discharge

- Jitter worsens at lower pressures

Reduced jitter by increasing discharge current

- 5× decrease with 500 A discharge

330 A ($R = 22 \Omega$)

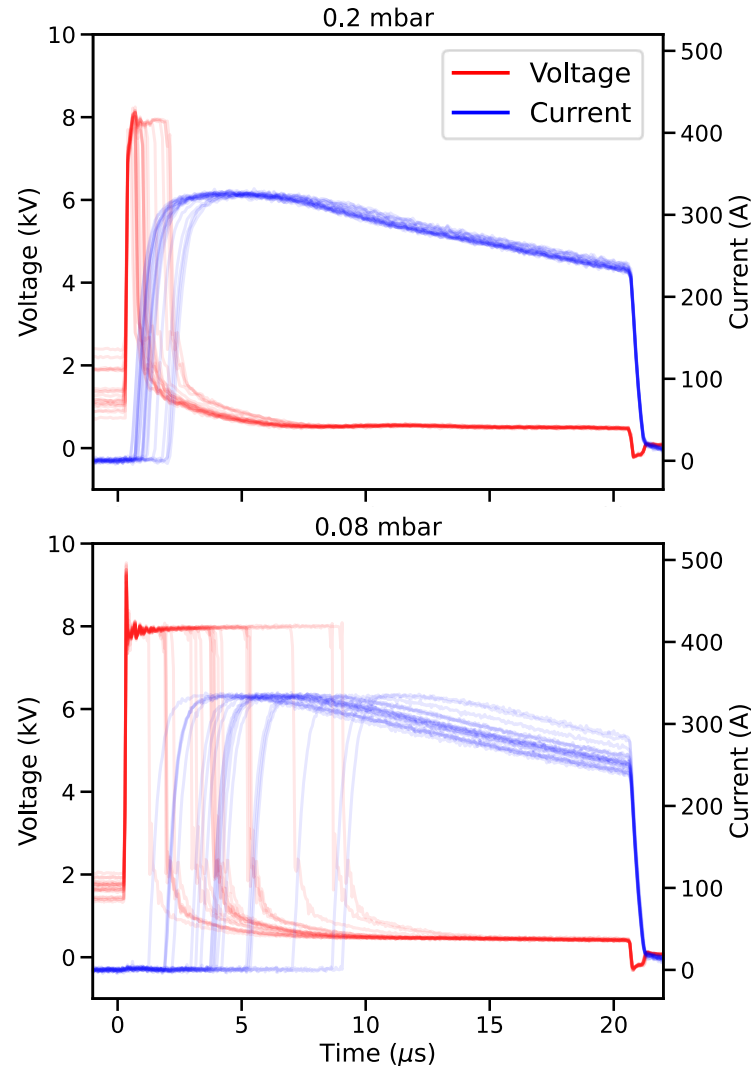

500 A ($R = 15 \Omega$)

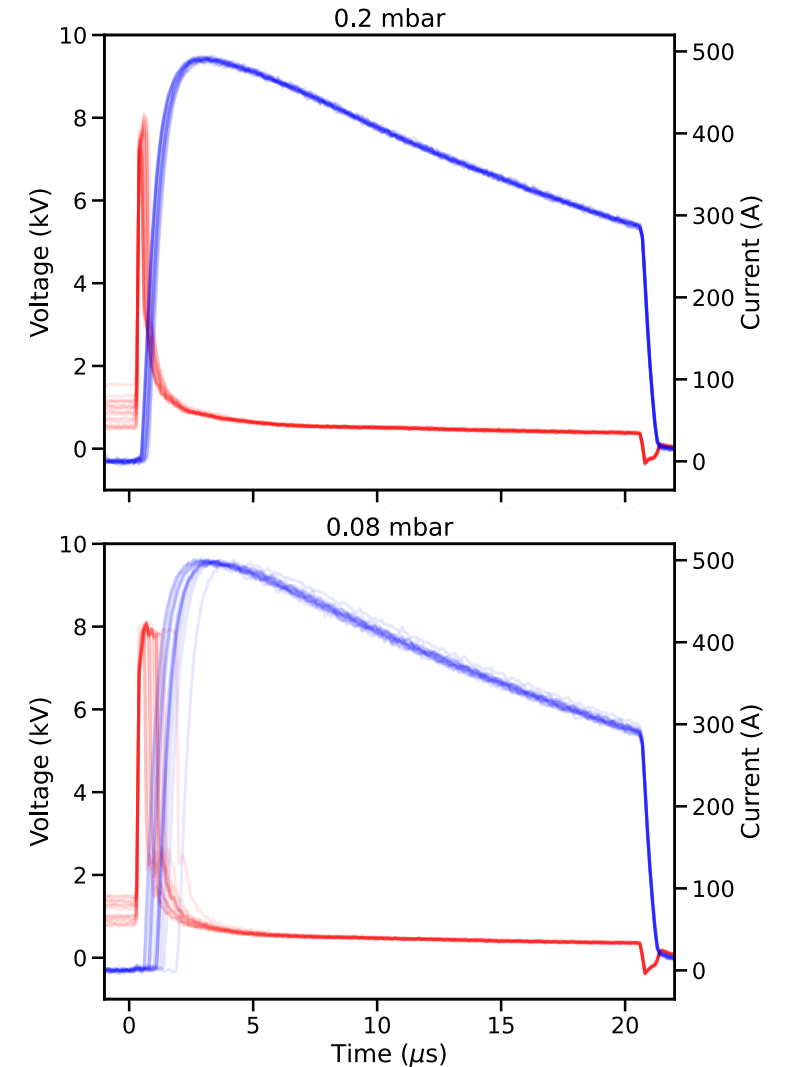

Longitudinal Interferometry

- Mach-Zehnder interferometer
- Longitudinally-integrated density measurement
- Transversely resolved
- Time scan possible by varying laser – discharge timing

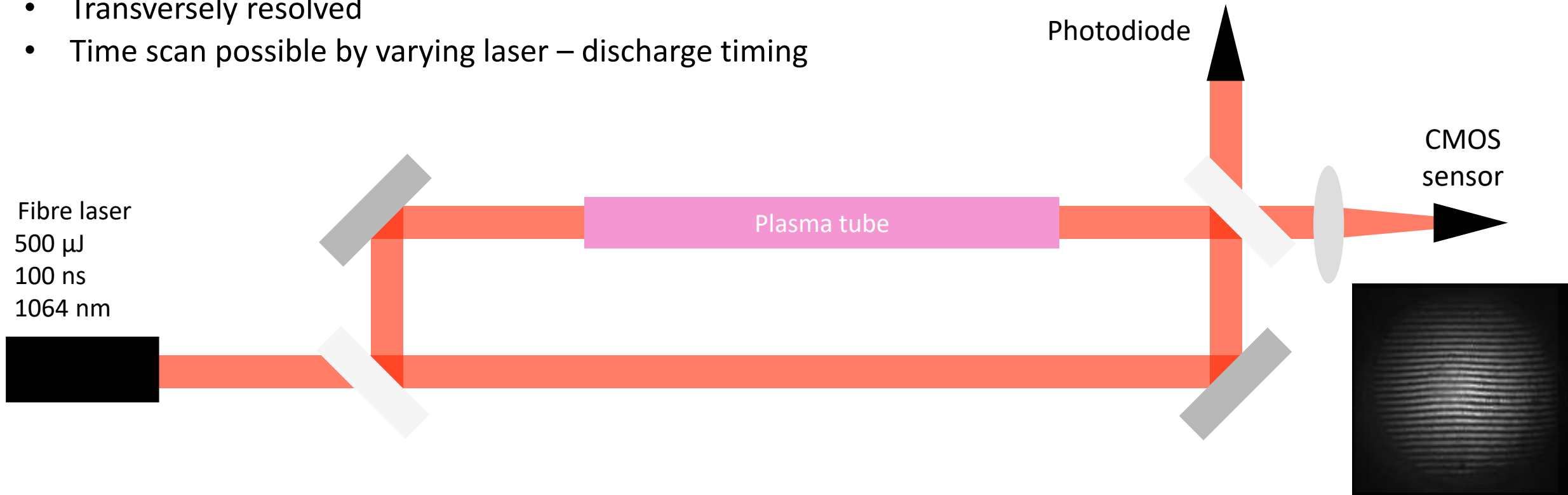

Plasma Current Scan

Gas	Argon
Pressure	0.2 mbar
Laser timing	3.5 μs

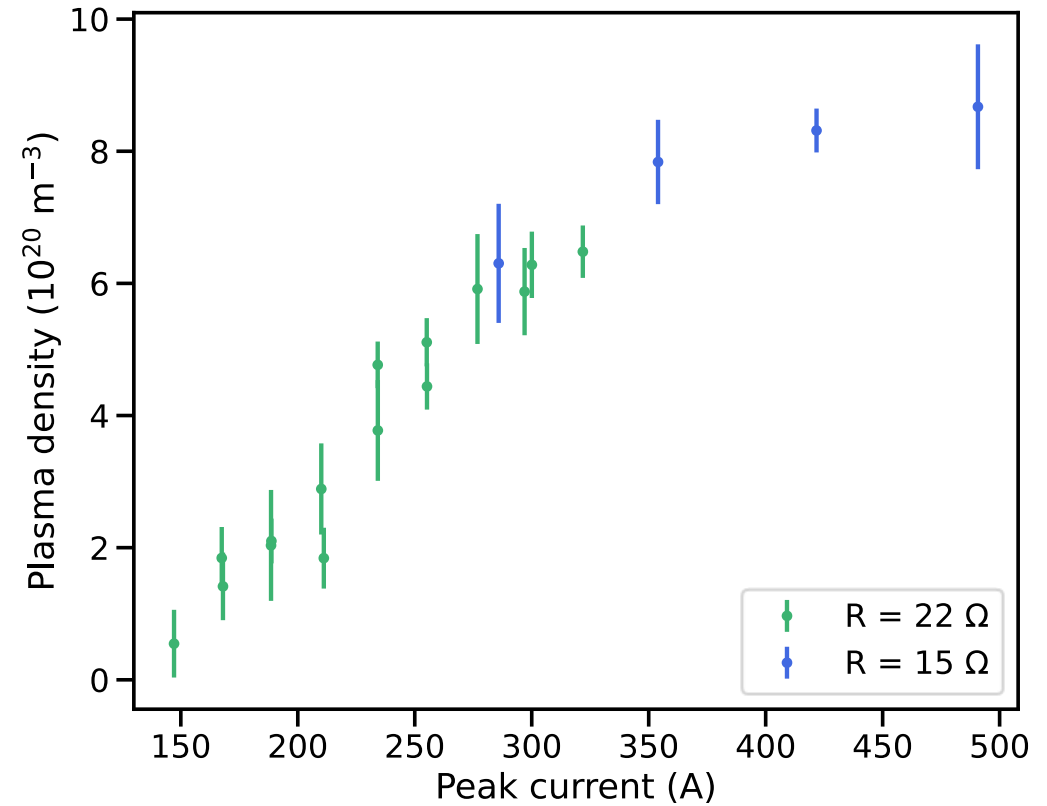
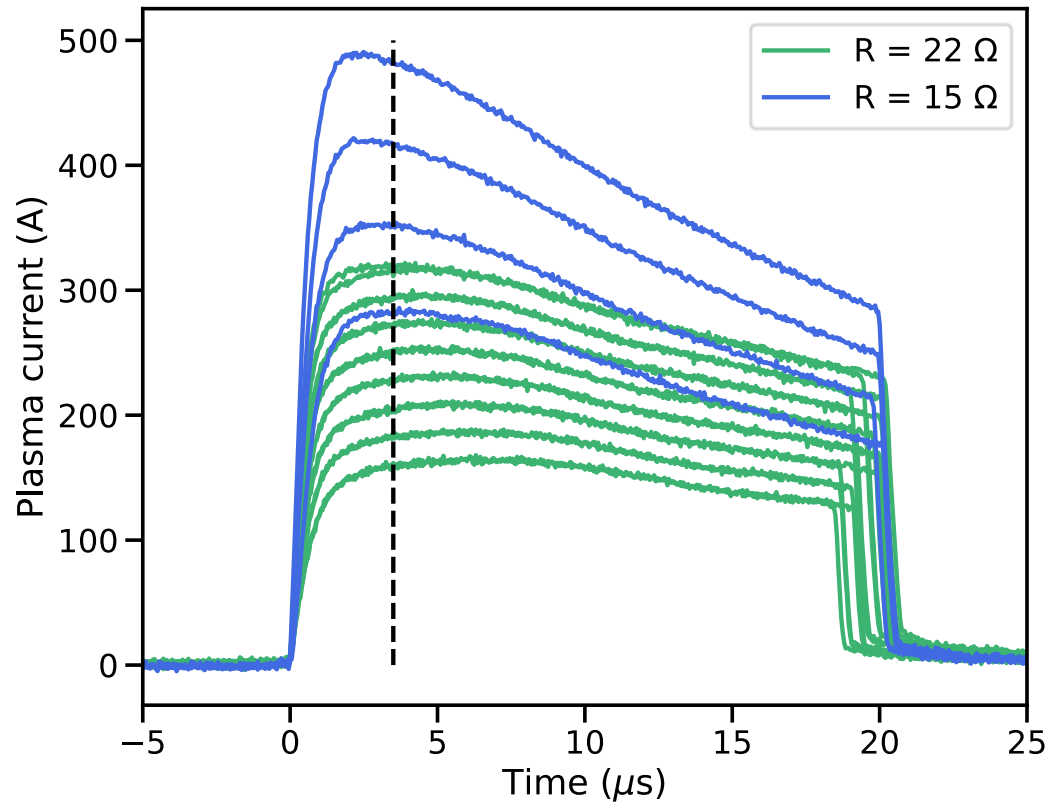

Peak densities $\sim 10^{21} \text{ m}^{-3} \rightarrow 30\%$ ionisation

Plasma density (ionisation fraction) increases with current

Plasma Channel Evolution

Argon, 0.2 mbar, 8 kV, 330 A ($R = 22 \Omega$)

Low Current

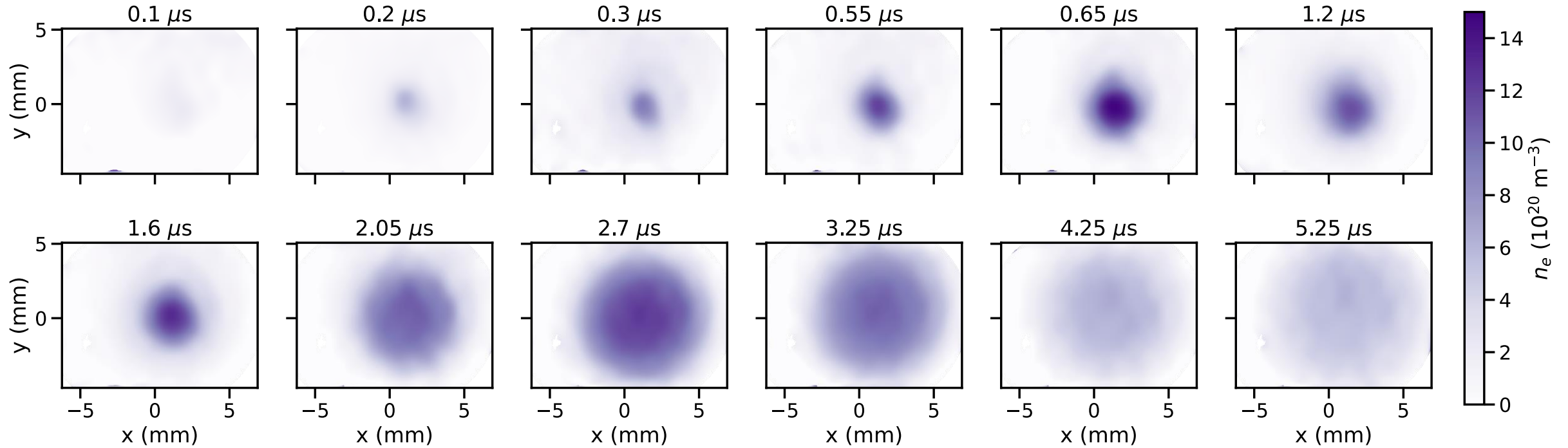

Plasma Channel Evolution

Argon, 0.2 mbar, 8 kV, 500 A ($R = 15 \Omega$)

High Current

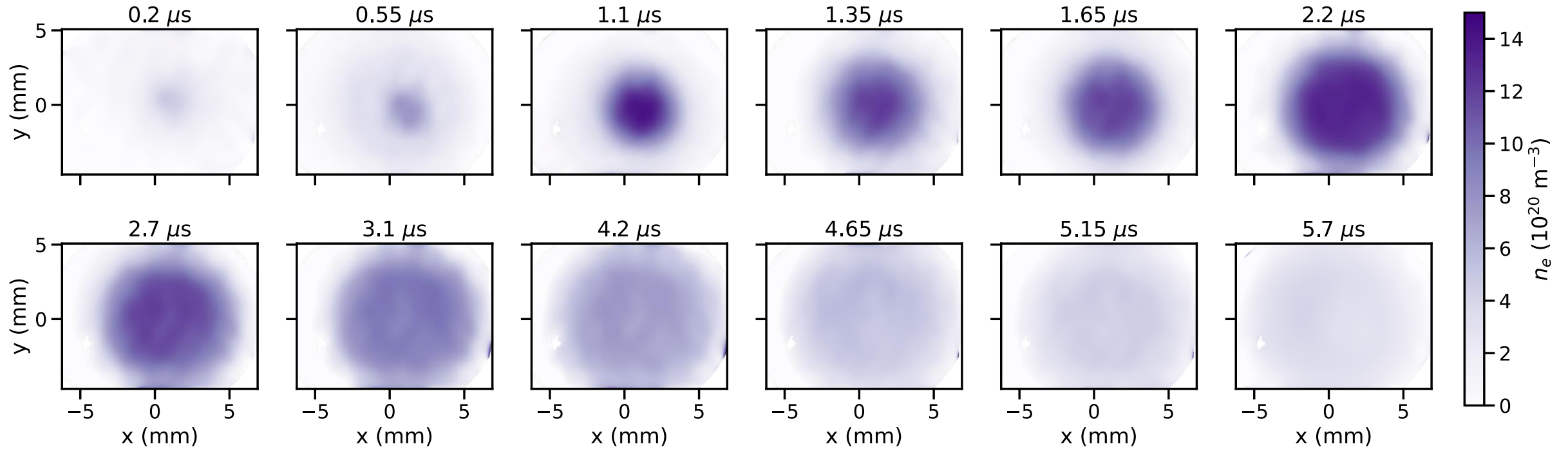

Plasma Density Evolution

Gas	Argon
Pressure	0.2 mbar
Voltage	8 kV

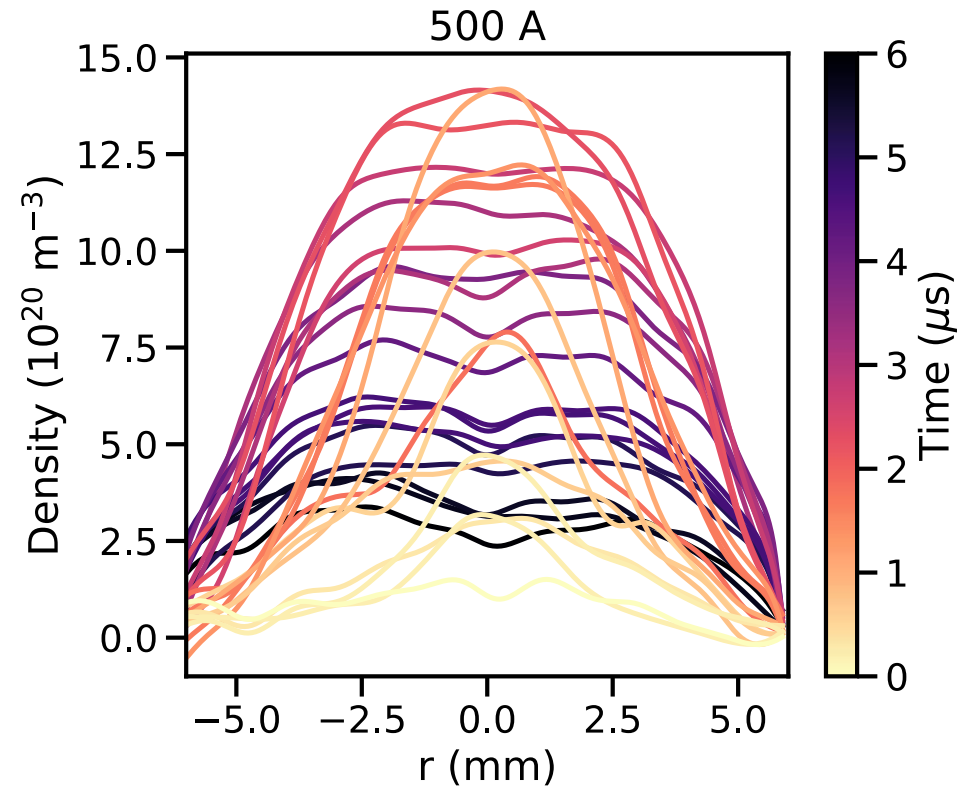
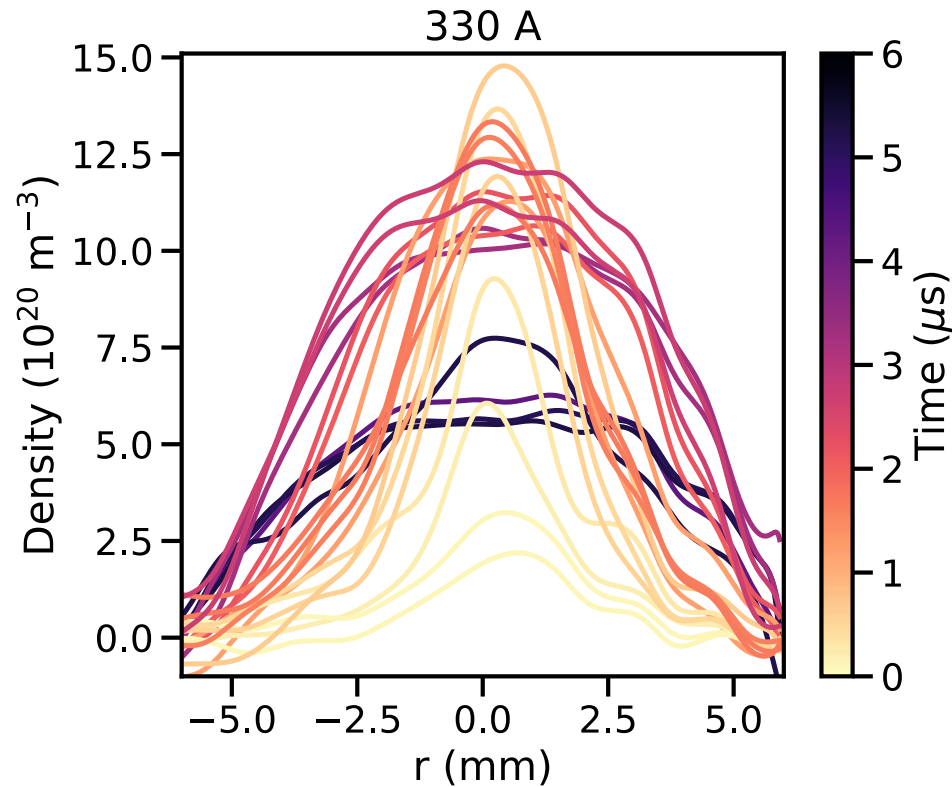

Rapid expansion early in the 500 A discharge counteracts faster ionisation by higher current

- Similar peak densities achieved with 330 A and 500 A

Plasma Density Evolution

Gas	Argon
Pressure	0.2 mbar
Voltage	8 kV

330 A

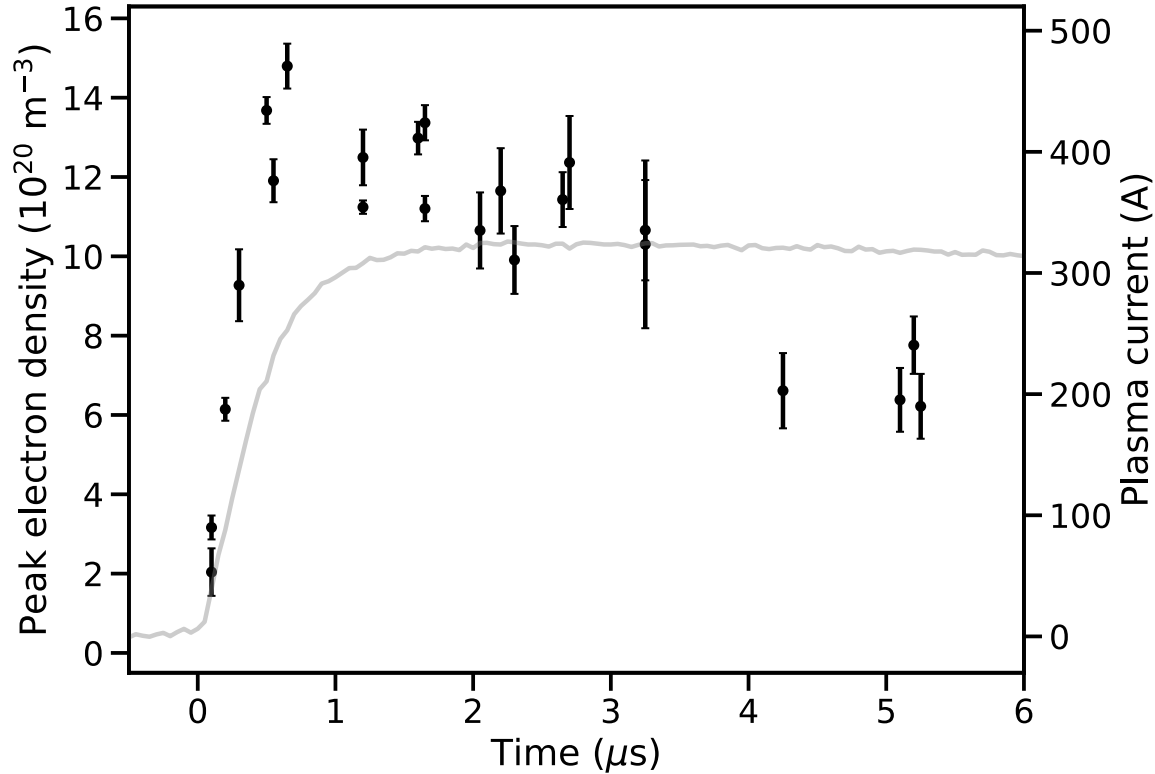

500 A

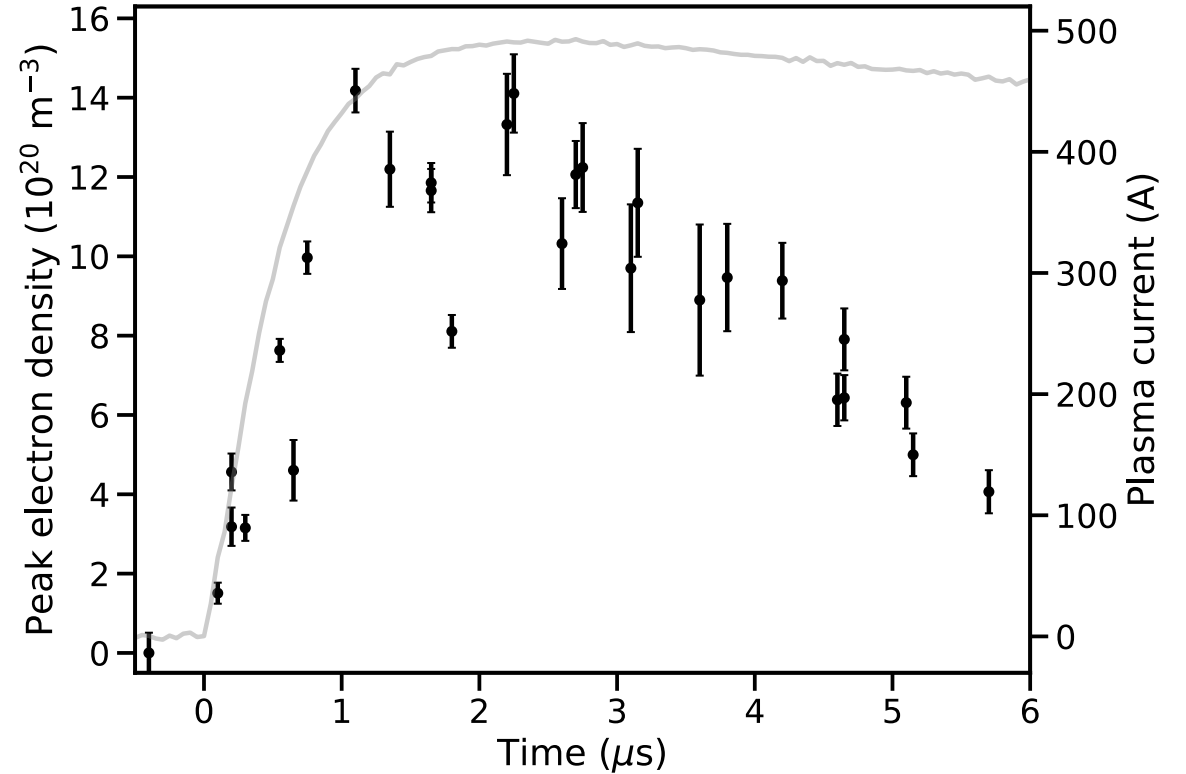

Plasma Emission Spectroscopy

Gas	Argon
Voltage	8 kV
Current	500 A

Bentham M300 Czerny-Turner spectrometer used to measure spectrum of plasma emission.

- Integrated over discharge pulse

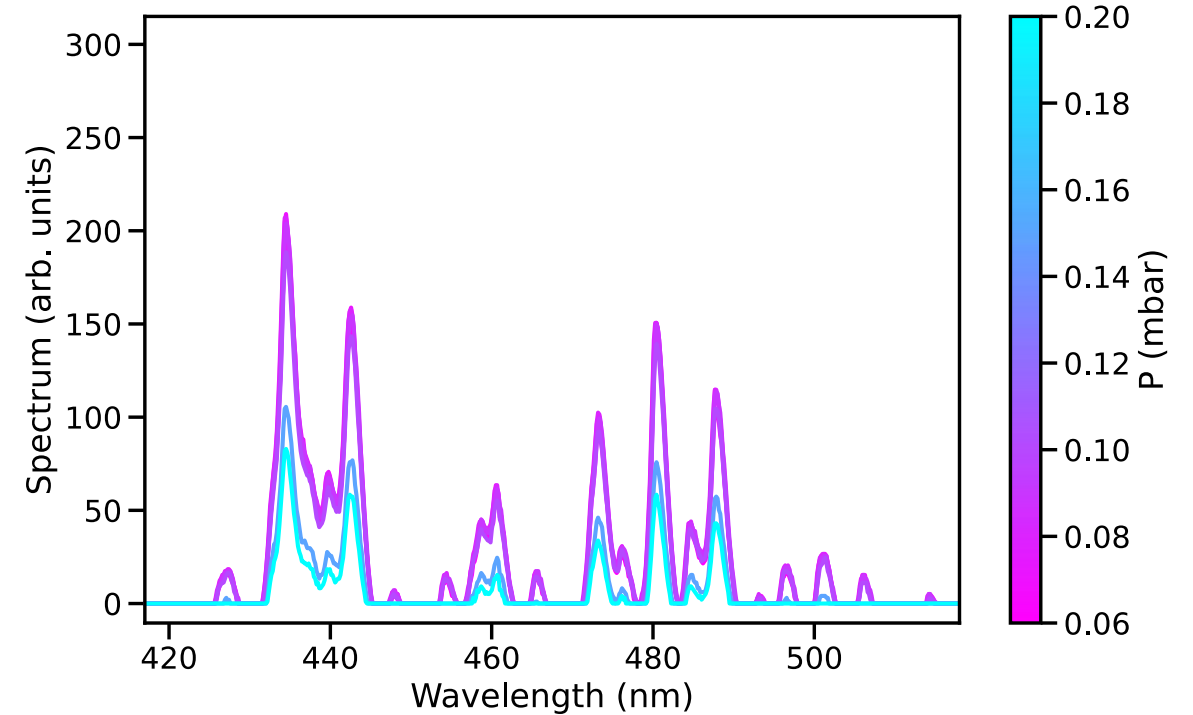
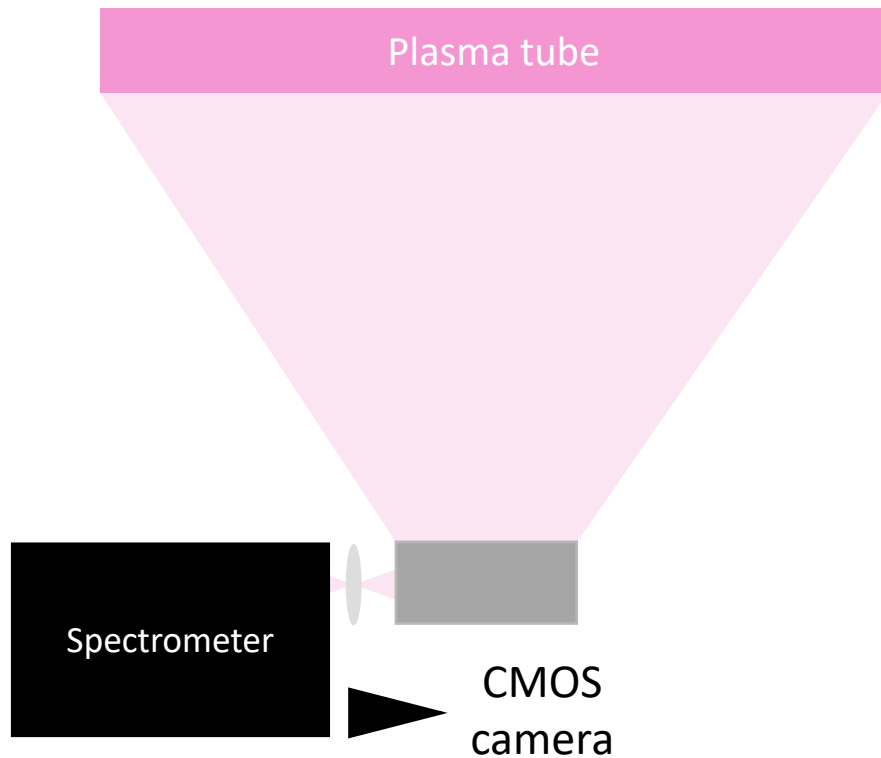

Plasma spectrum dominated by Ar II (singly ionised argon)

Plasma Emission Spectroscopy

PrismSPECT Simulations

Gas	Argon
Pressure	0.06 mbar
$\Delta\lambda$	2 nm

Collisional-radiative spectral analysis code

- Low temperature spectroscopy
- Zero width geometry
- Non-LTE

Spectra suggest $T_e \approx 1.5 - 2$ eV

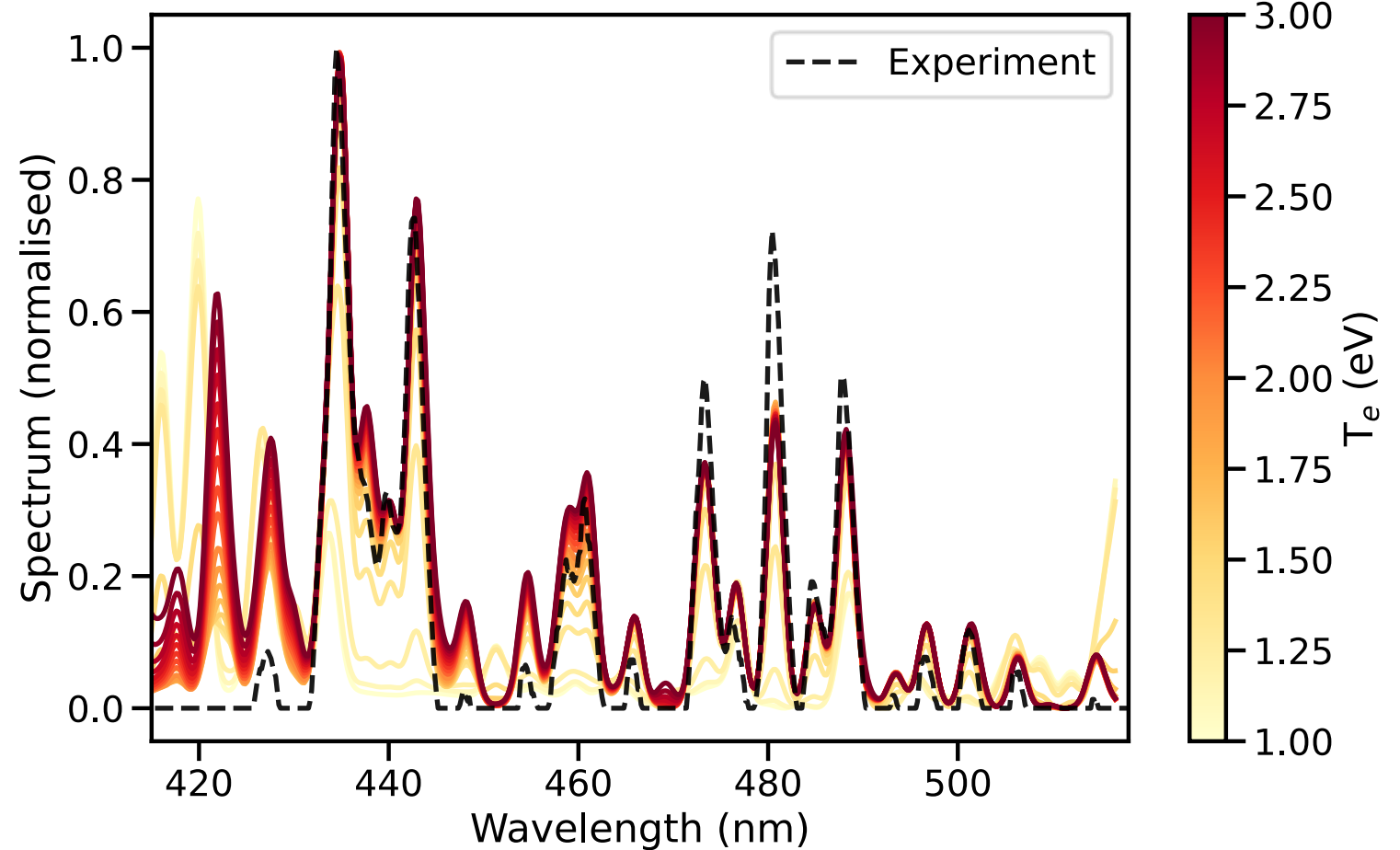

Conclusions

1 m argon arc discharge using 8 kV pulse generator

Higher current leads to more reproducible discharge

Longitudinal interferometry reveals radial expansion of plasma during discharge pulse

- $n_e \sim 10^{20} - 10^{21} \text{ m}^{-3}$ densities reached
- Complex ionisation and diffusion dynamics to be investigated further with PIC simulations

Plasma emission spectroscopy provides information about the plasma temperature

Acknowledgements

AWAKE scalable plasma sources R&D team

