



UNIVERSITY OF  
OXFORD



# High Frequency Beam Position Monitor Solutions for the Advanced Wakefield experiment

---

JAI Fest 2025  
Bethany Spear

# The AWAKE experiment

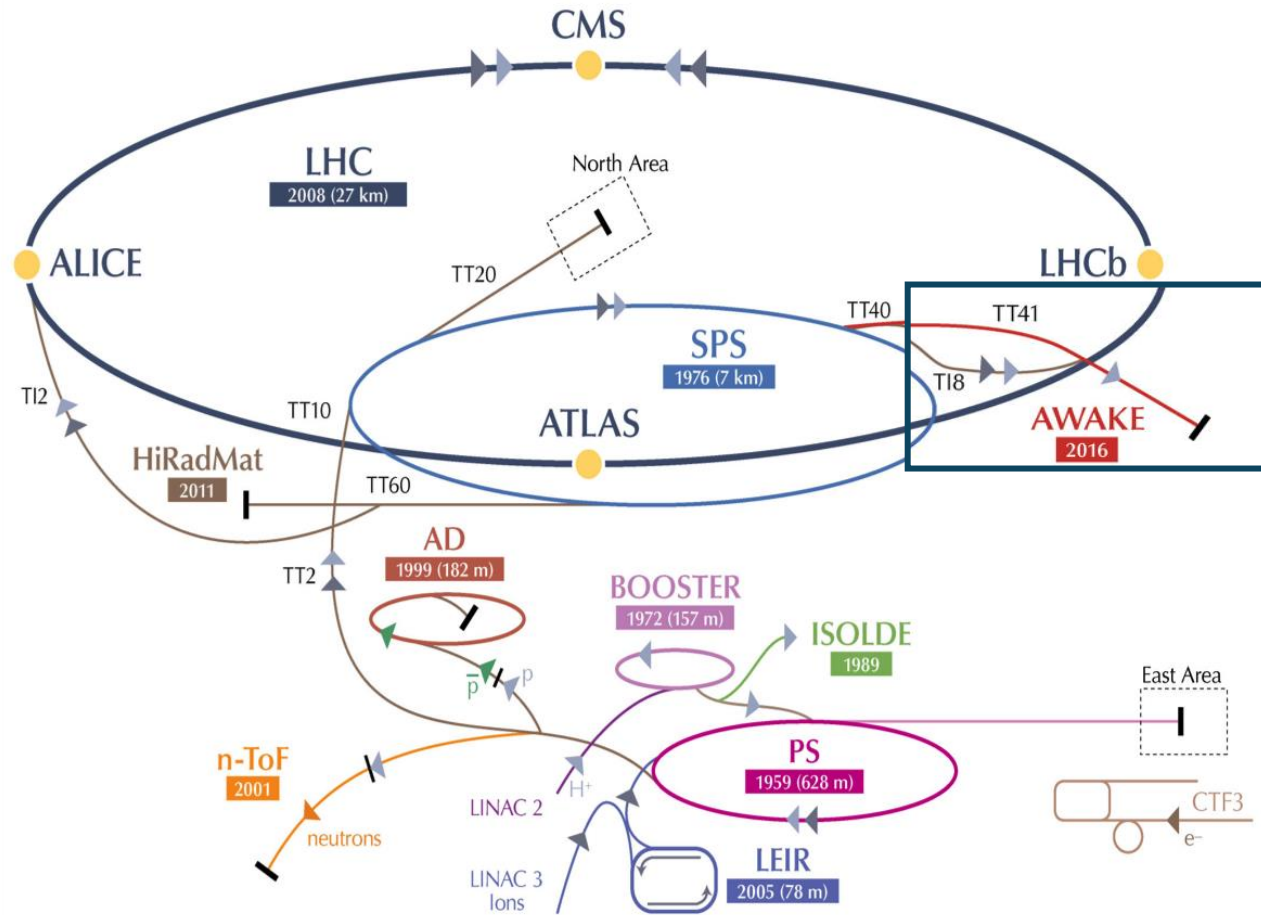

## The Advanced WAKEfield experiment

- R & D Experiment into PWFA
- Using Protons from the SPS
- Accelerate electrons

# The AWAKE experiment

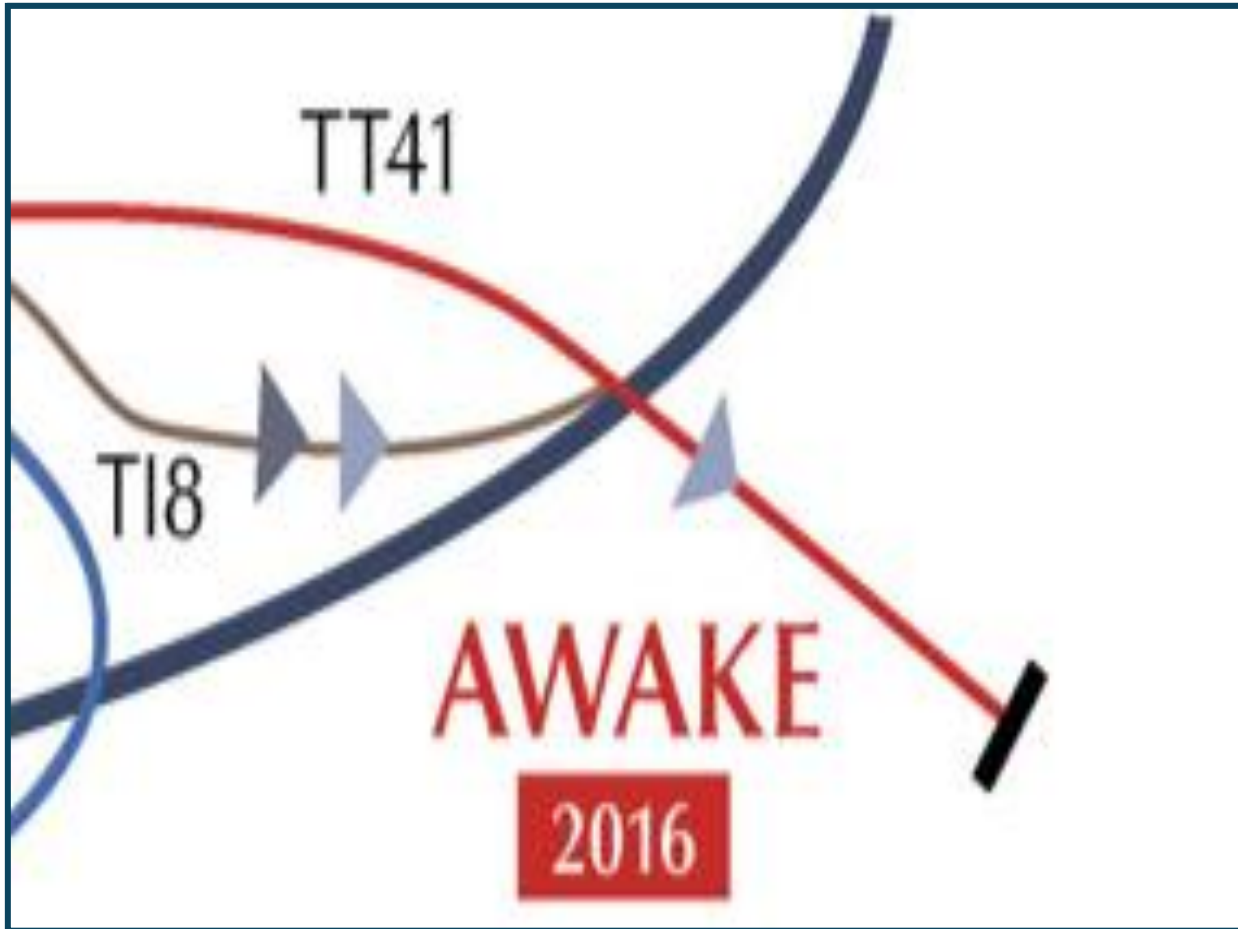

- 10m **Rubidium** vapour source
- Ionised by a **Laser** pulse to create **Plasma**
- **SPS Protons** (400GeV) drives wakefields in the plasma
- Externally injected **electrons** (20MeV) for acceleration

## Run 1: 2017–2021

- ✓ Demonstrated **seeded self-modulation** of the proton bunch and drive strong wakefields
- ✓ **Accelerate** externally injected electrons to 2 GeV (average accelerating gradient of 200 MV/m)

# Capacitive BPMs

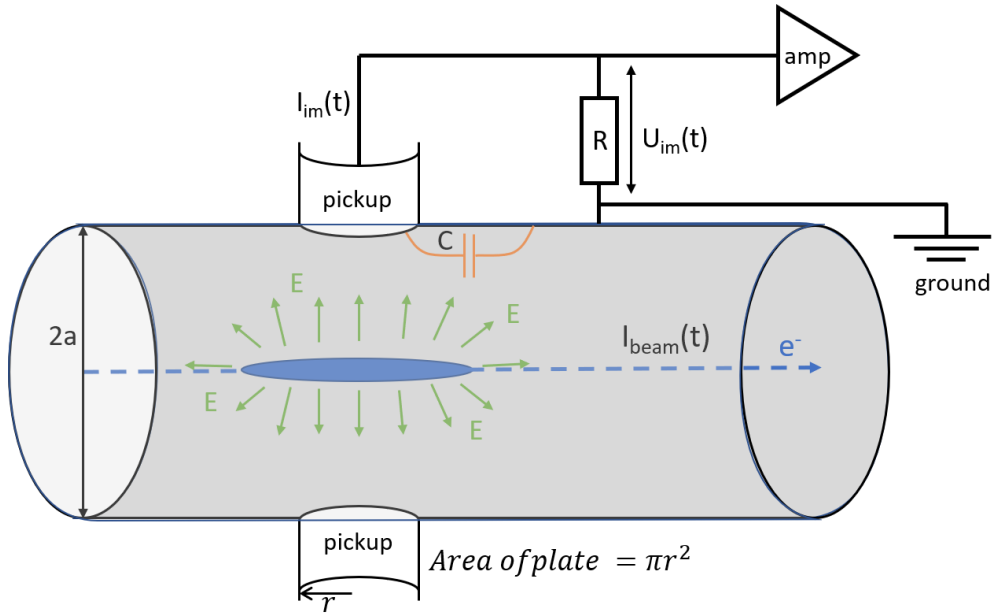

The beam is a moving line of charge. As it passes, it **induces image charge** on nearby conductive surfaces. Each electrode forms a **small capacitance** to the beam/beam pipe, so beam motion creates a **time-varying induced voltage** on the electrode

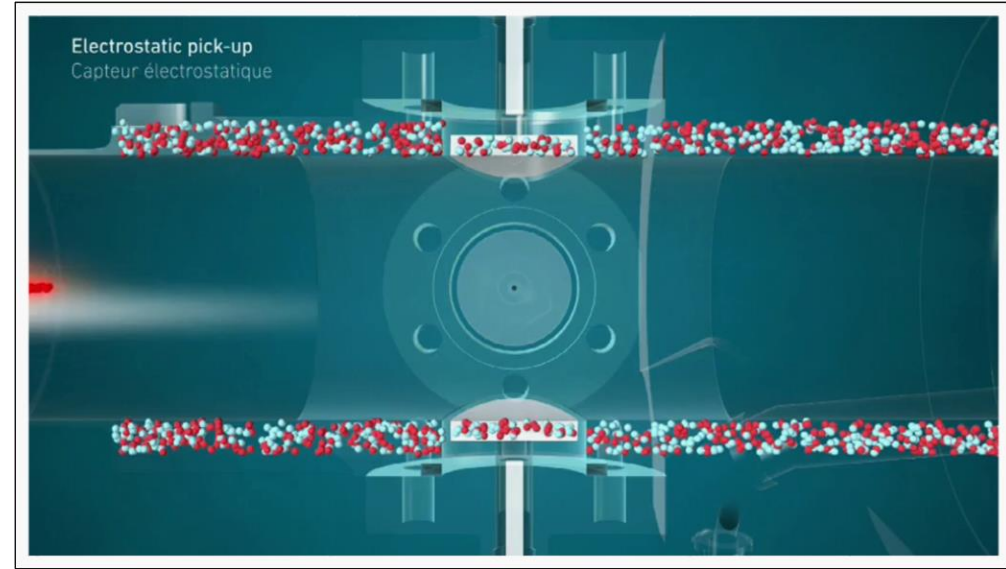

If the beam is centred, opposite electrodes see **equal** induced signals. If the beam shifts toward one side, the nearer electrode sees a **larger** signal and the farther one sees a **smaller** signal.

$$x = \frac{1}{S_x} \frac{U_{\text{right}} - U_{\text{left}}}{U_{\text{right}} + U_{\text{left}}} + \delta_x \equiv \frac{1}{S_x} \frac{\Delta U_x}{\Sigma U_x} + \delta_x,$$

# Current Electron BPMs

Precise injection of the electron beam onto the plasma wake is **essential** for acceleration

The problem:

- Proton bunches are longer (~250ps), and higher charge (48nC) than the electron bunch (~1-5ps), (100pC).
- At 404 MHz signal dominated by protons.
- Current stripline eBPMs unable to measure beam position when protons are present.

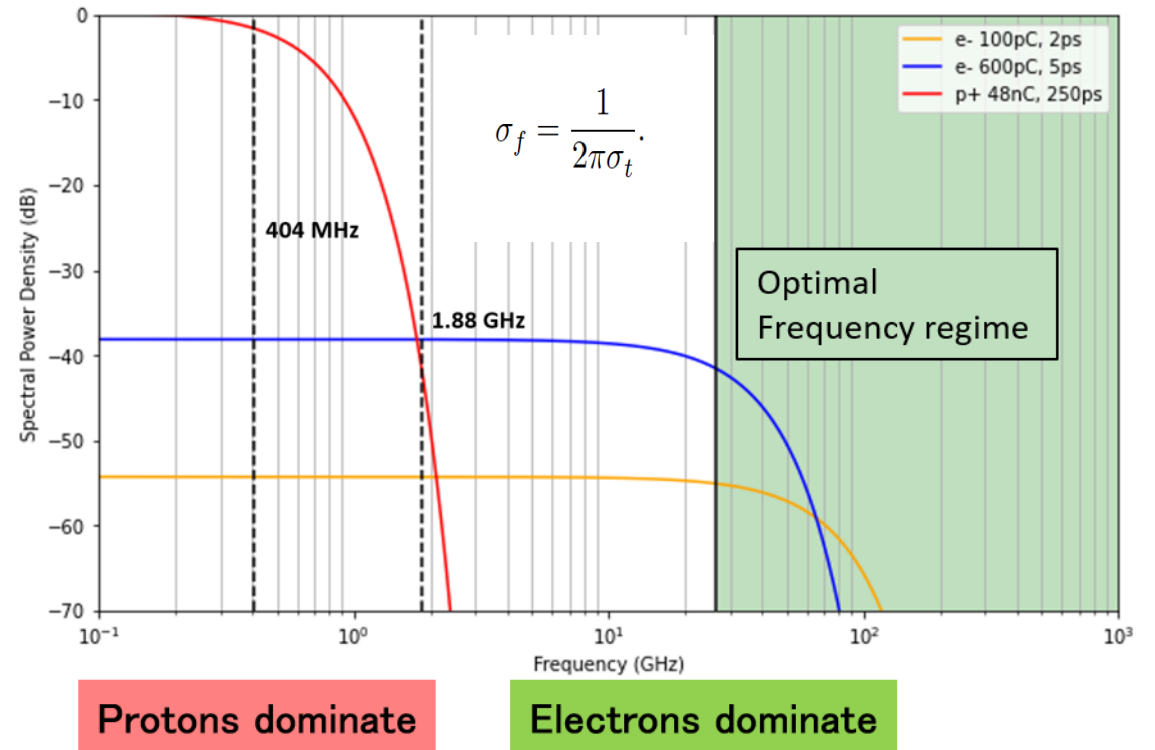
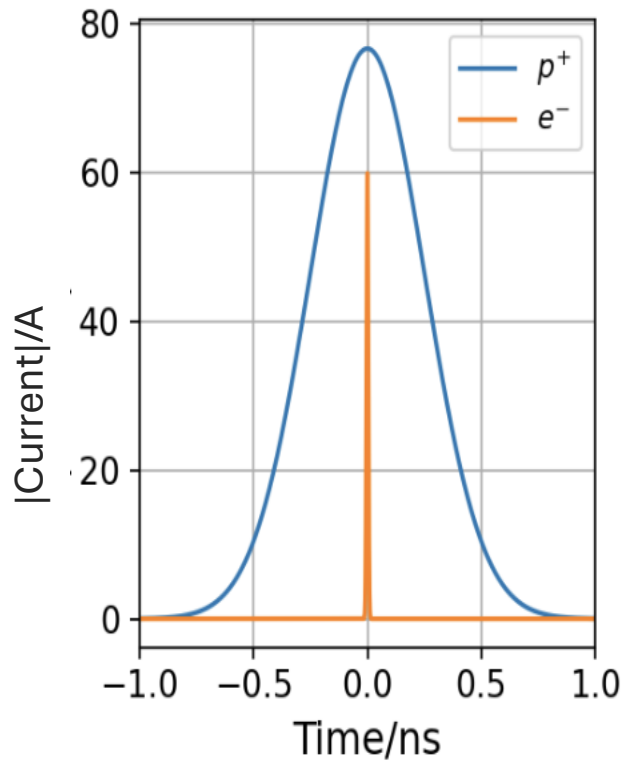

The solution:

Need for a system performing the detection at sufficiently **high frequencies (MHz → GHz)**

# High Frequency Beam Position Monitors 1

## Option 1: Cherenkov Diffraction based BPM

➤ **Cherenkov Diffraction Radiation** is a type of **polarization radiation** generated by the field of a particle beam as it passes in **close proximity** to a dielectric radiator.

➤ Propagates inside the dielectric at the **Cherenkov angle**.

$$\theta_{ch} = \cos^{-1} \left( \frac{1}{n\beta} \right)$$

➤ BPM based on ChDR is advantageous as it is **non-interceptive** and the radiation is emitted at a well-defined angle.

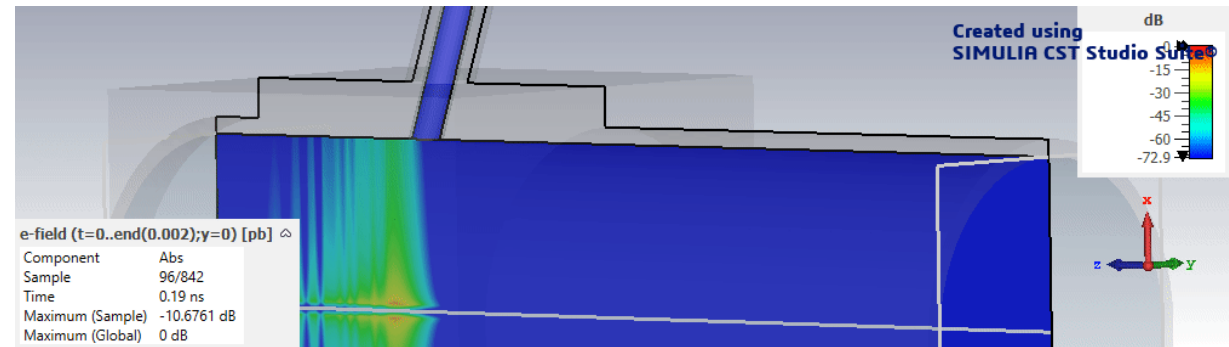
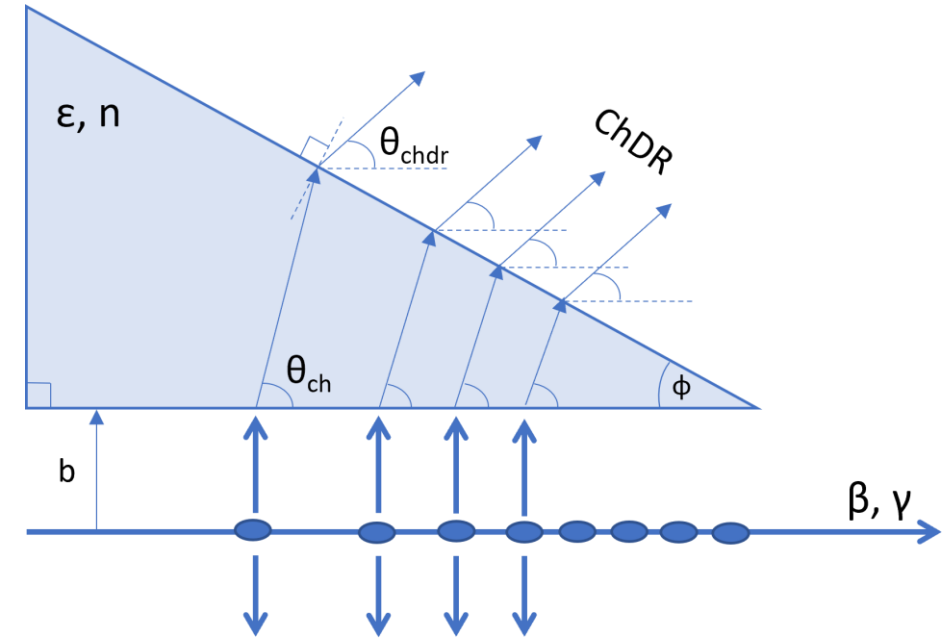

# High Frequency Beam Position Monitors 1

## Option 1: Cherenkov Diffraction based BPM

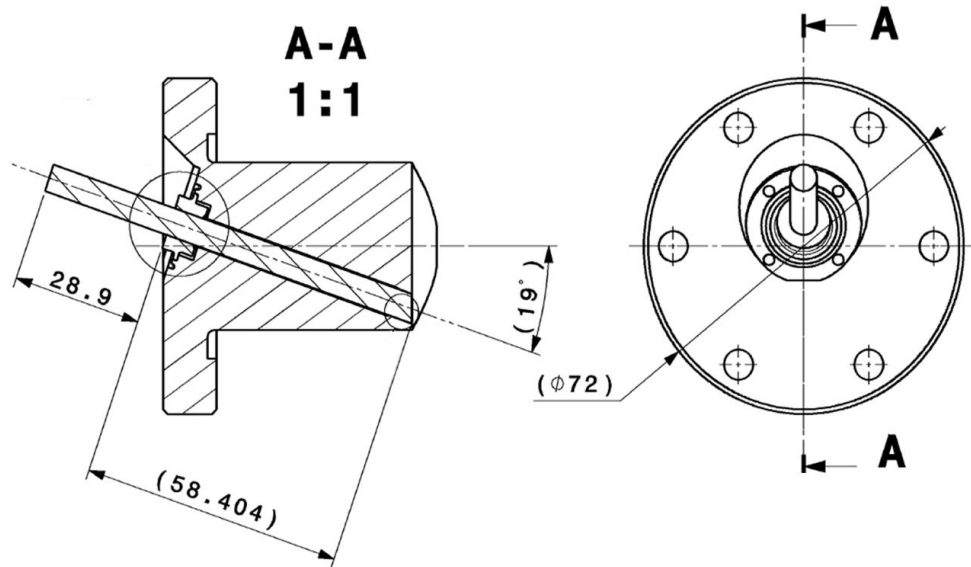

- $\varnothing 6$  mm, 86 mm long alumina rods angled at the Cherenkov angle ( $71^\circ$ ), 9.6 GHz cut-off
- Respects the geometry of existing pBPM body



# High Frequency Beam Position Monitors 2

## Option 2: High Frequency Button BPM

- Conical shaped High Frequency button BPM
- One design in literature working above 40 GHz cutoff frequency

See A. Angelovski et al., Phys. Rev. ST Accel. Beams **15**, 112803 (2012)

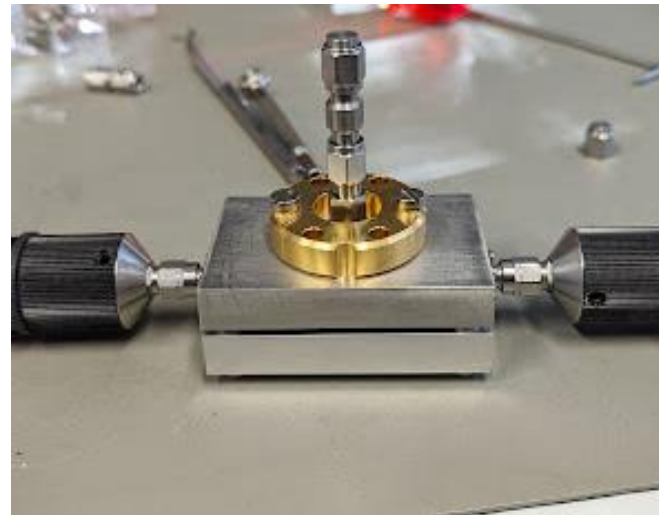
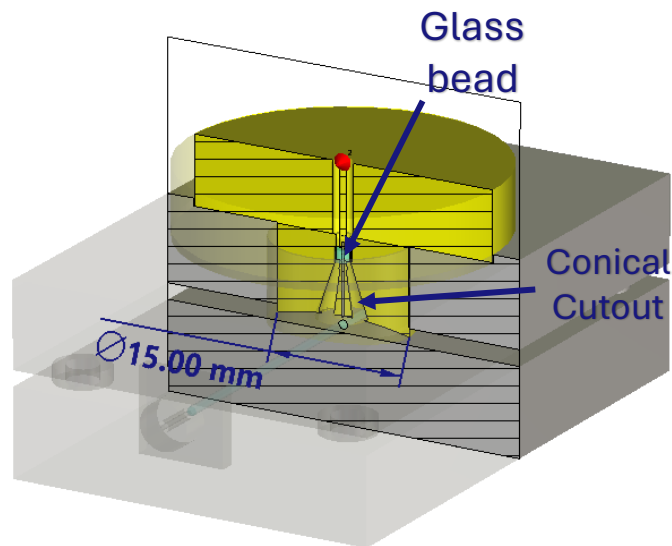

*Comparison to LHC-type Button BPM*

the cone-shaped pickup avoids resonances within the pickup due to the tapered transition from the beam pipe to the connector

# Beam Testing – Setup

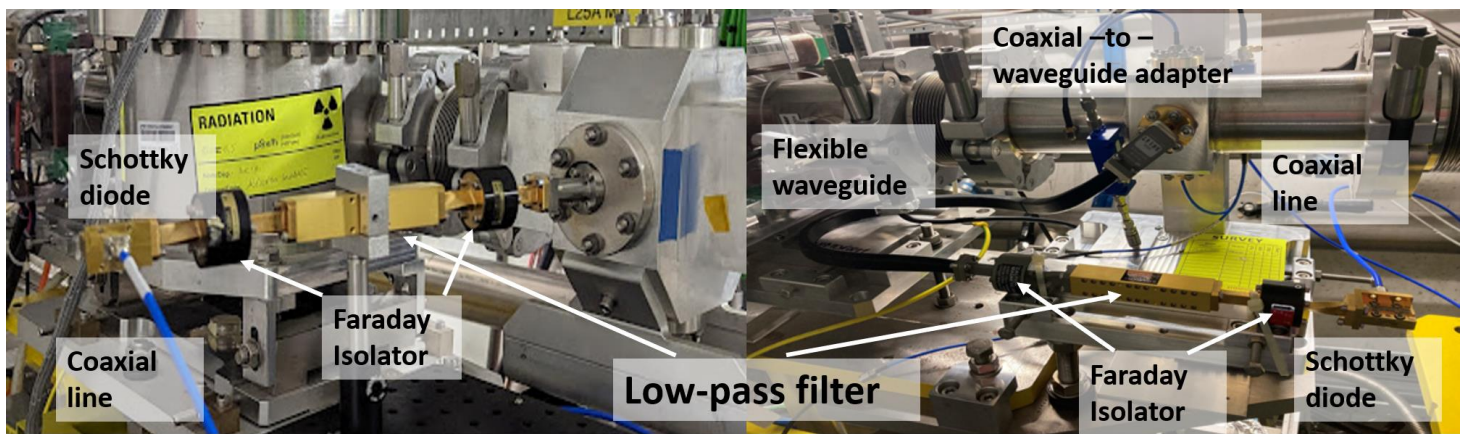

The Ka-Band read-out arms are identical and pass a frequency range  $\sim 20..32$  GHz, given by the low-pass filter and the WR28 dimensions. At the end there is a Ka-Band diode detector

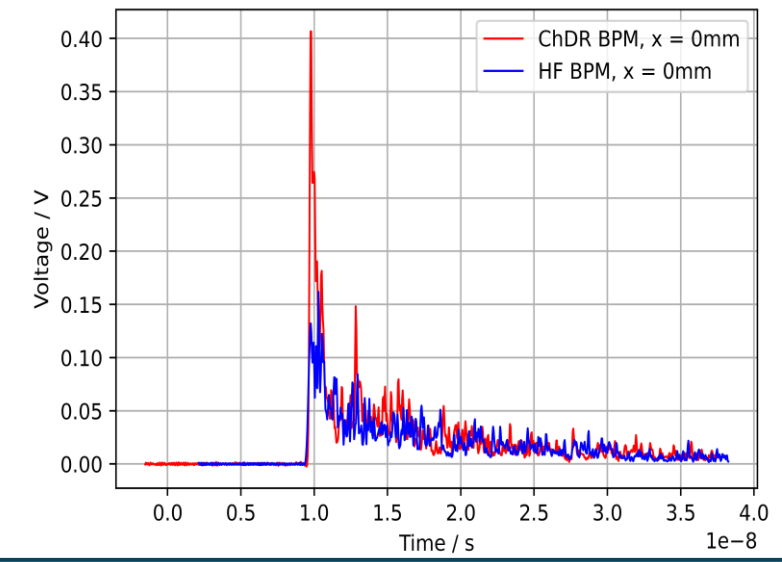
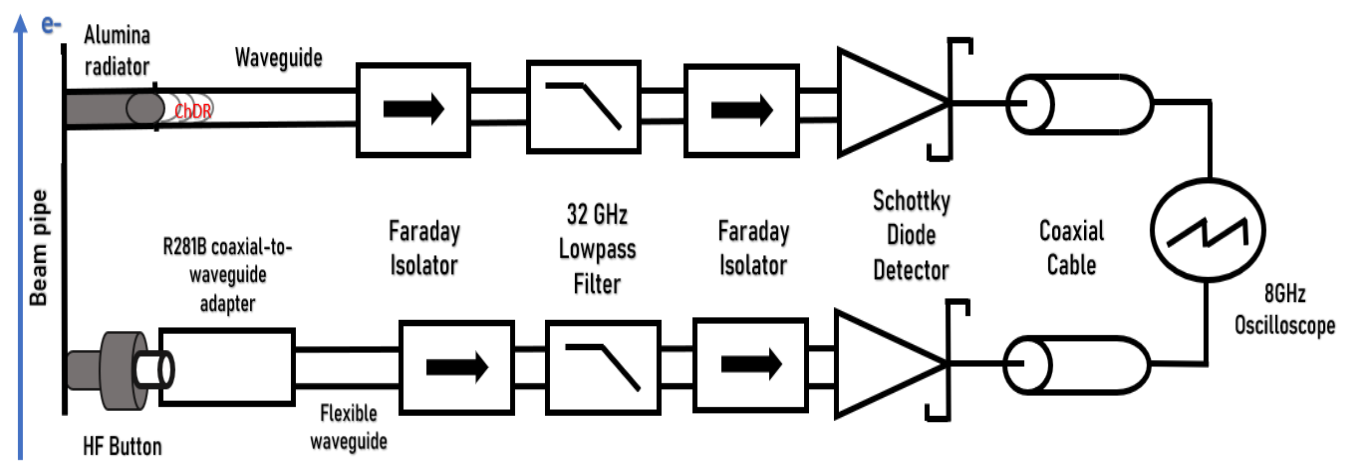

# Beam Testing – Response to the electron beam

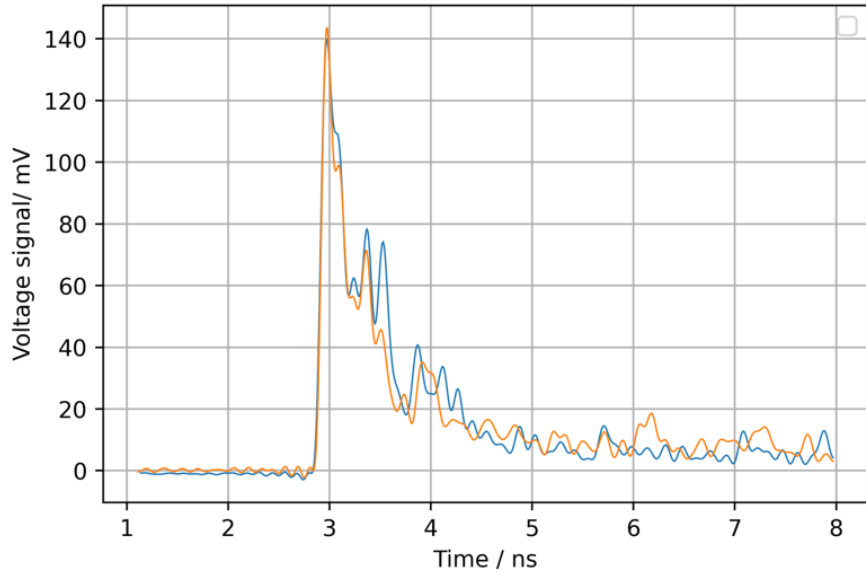

We compare the waveform response from 2 opposite Cherenkov pickups and show that when a (100 pC) electron beam is centred in the beam pipe, the signal response is nearly identical.

- The electron beam is moved across the horizontal plane of the beam pipe using correcting magnets upstream of the BPMs
- At each position we record the signal waveform over 30 seconds and taken an average.
- We predict that the opposite pickup would produce an equal but opposite response
- The position sensitivity of each BPM is then calculated using the value of the peak voltage at each position as the % change in the signal per mm

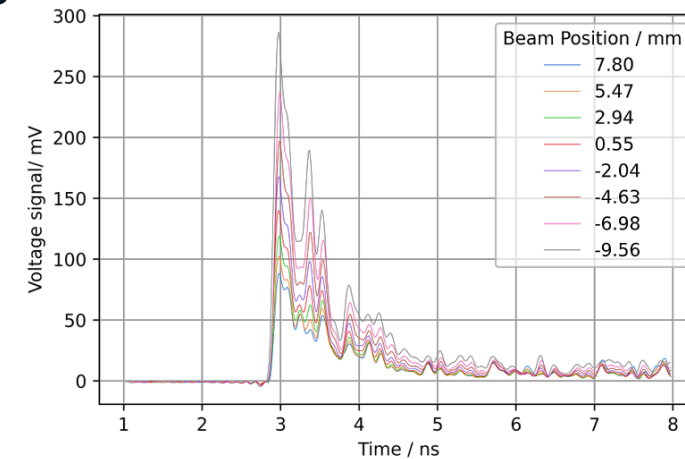
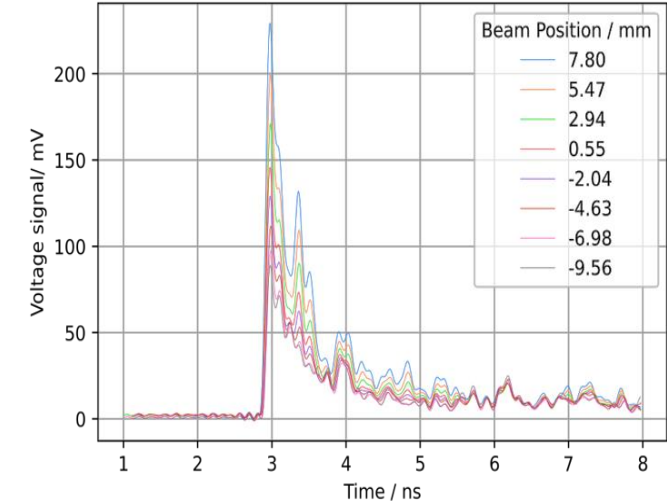

# Beam Testing – Introducing the Protons

- The proton beam is extracted from the SPS up to every 15 seconds with a bunch population of between 1 and  $3 \times 10^{11}$  protons.
- When these arrive we extract the waveforms from the BPM and compare them to the waveforms when only the electrons are present.

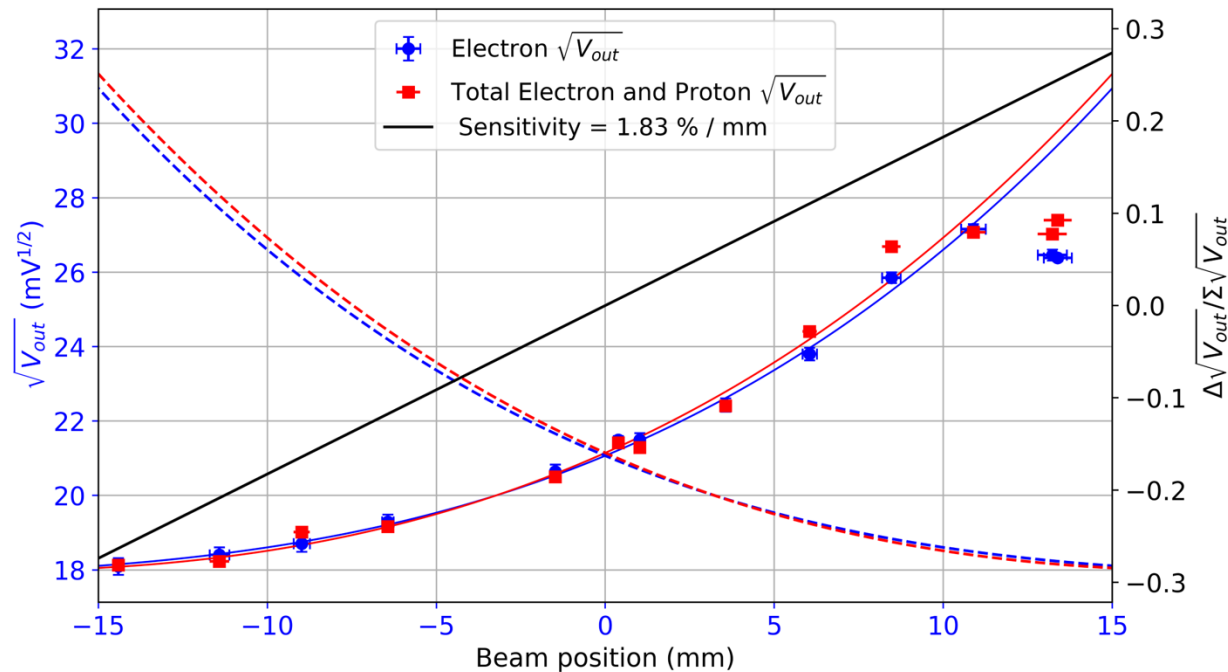

- Barely any change in the signal when the  $1 \times 10^{11}$  protons are present
- Consistent sensitivity with electron only operation
- Successfully discriminates electron position from the proton bunches
- True for both ChDR and conical HF BPMs

# Beam Testing – Introducing the Protons

- Issues arise when the intensity of the proton bunch is increased

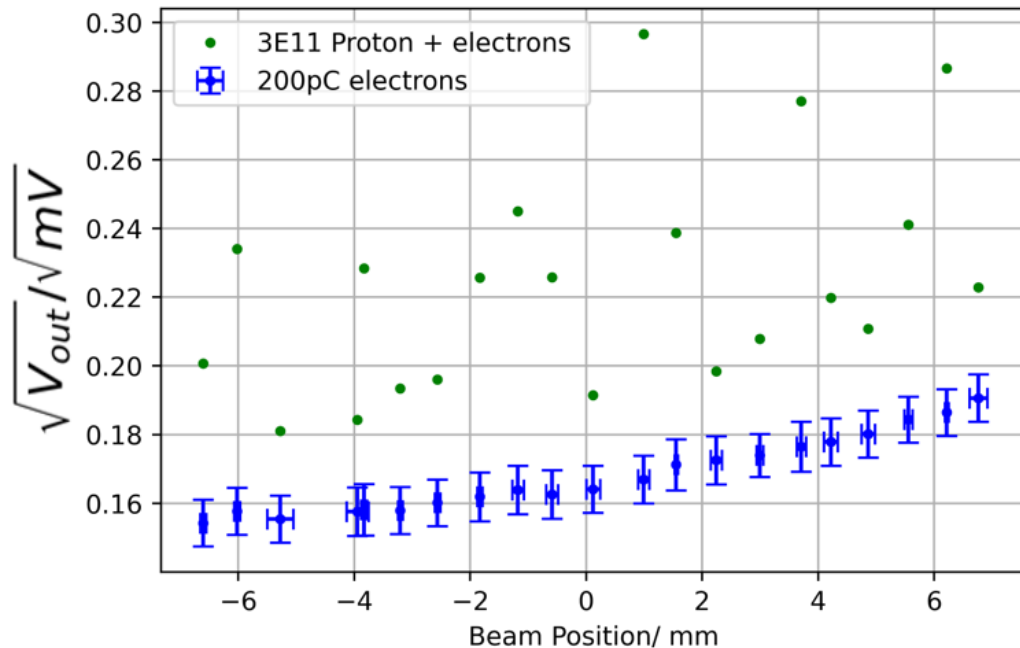

- We now see an **additional** contributed voltage on top of the electron signal

## So what is happening?

- The frequency spectrum of the proton bunches are extending much higher than predicted!
- We can look to mitigating this by going to even higher frequencies...

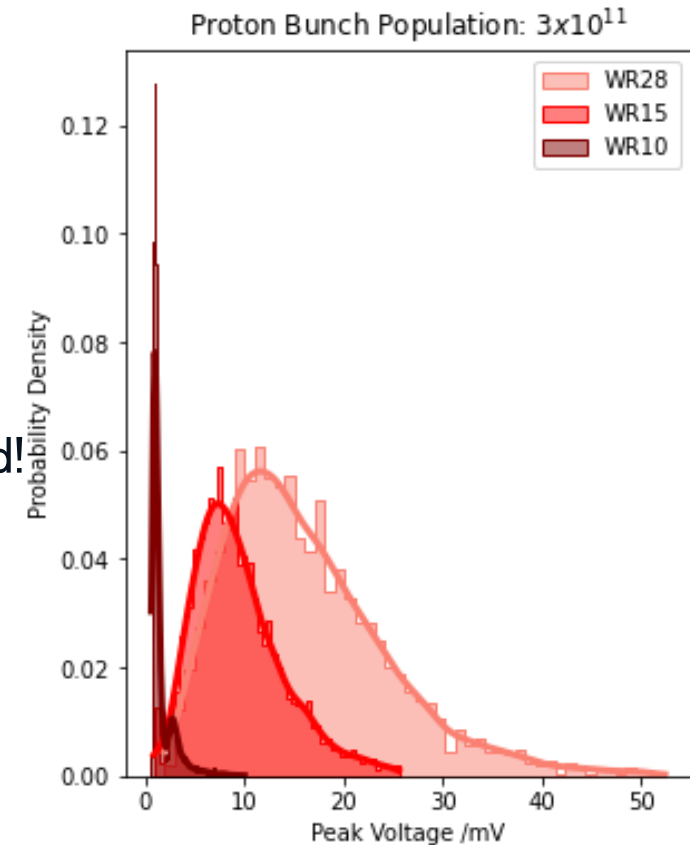

# TRIUMF commissioning + installation

Continuous logging of the electron beam at 10 Hz via an external trigger.

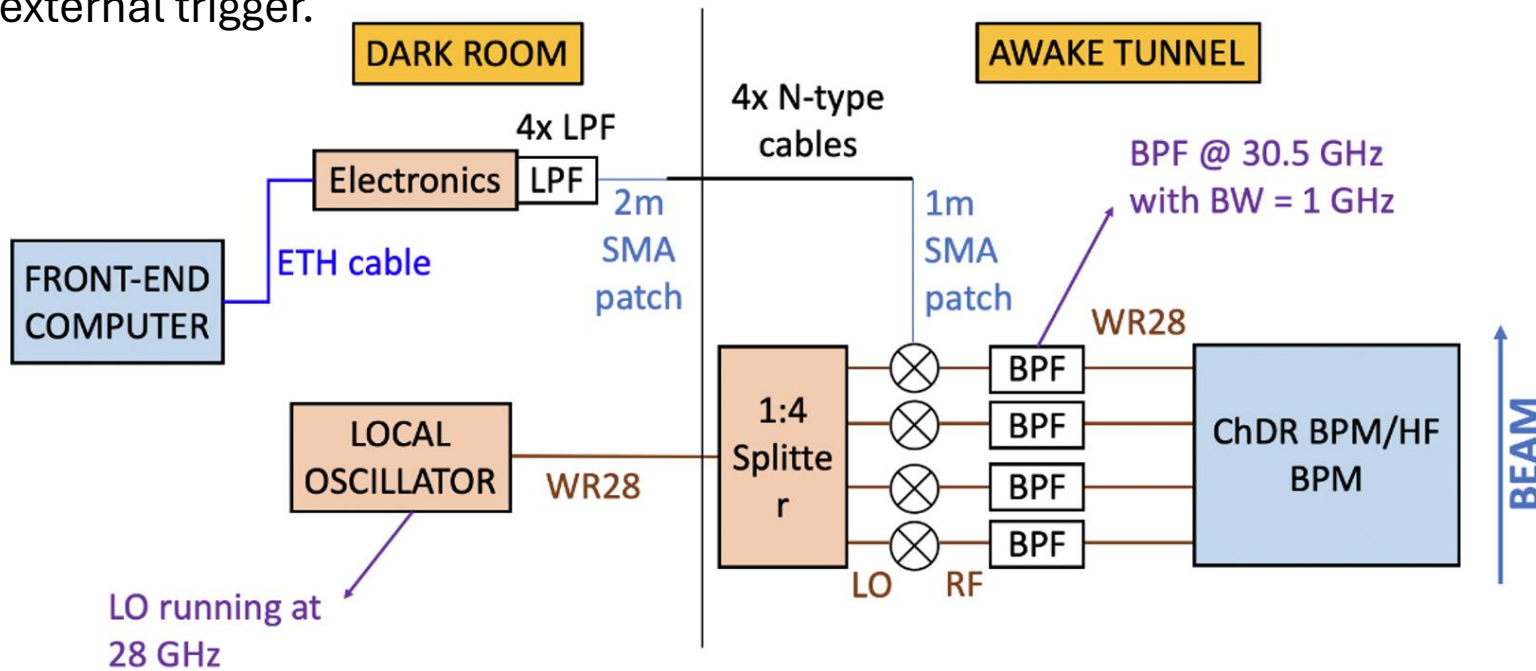

- The HF pick-ups are connected to coaxial-to-WR28 waveguide adapters.
- Both pick-ups are connected to two identical signal processing electronics, which detect the BPM pick-up signals at the WR28 waveguides in the frequency band between 26.5-40 GHz.
- In the RF front-end, the signals are passed through bandpass filters (BPF) with 30.5 GHz central frequency and 1 GHz bandwidth (BW) before being down-converted to an intermediate frequency (IF) of 2 GHz.
- The IF signals are demodulated and digitized in the following back-end electronics, designed by TRIUMF.
- Full integration in FESA.

# Next steps

- I have finished my PhD (yay) but there is currently no plan for the development of either BPM
- Additional R&D would be needed to improve performance at high beam intensity.
- Could include moving to a higher frequency acquisition system to see how high we would need to go.
- Redesign of the front-end.
- Only feasible for the ChDR BPMs as bandwidth of HF components above 40 GHz begin to include large resonances.
- Alternatively, an online measurement of the proton profile to compliment the current measurements.



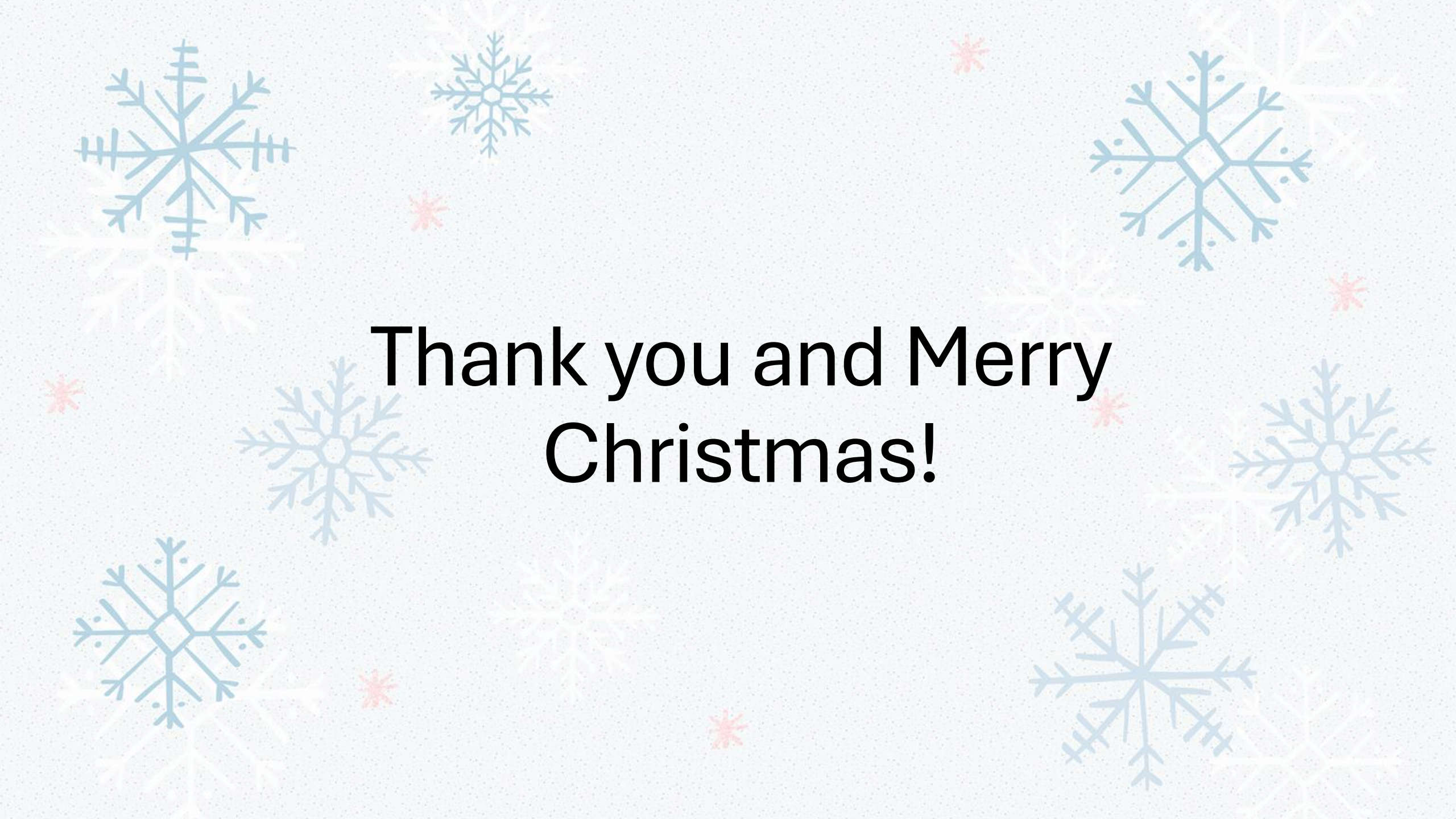

**Thank you and Merry  
Christmas!**